

# Uni-Drum<sup>TM</sup> Supply System

309028ZAU

EN

***Bulk Supply System for 300 Gallon (1200 Liter) Magnadrum. For professional use only.***

**Not approved for use in explosive atmospheres or hazardous (classified) locations.**

The Uni-Drum Supply System evacuates 300 gallon (1200 liter) magnadrum or other tote drums of the same size and capacity. The Uni-Drum Supply System pumps and transfers flowable and highly viscous materials such as sealant, adhesives, and sound deadeners from bulk drums with maximum efficiency.

The Uni-Drum Supply System is designed to work with other high pressure equipment to optimize material use.

*See page 4 for model information.*



## Important Safety Instructions

Read all warnings and instructions in this manual and related manuals before using the equipment. Save these instructions.

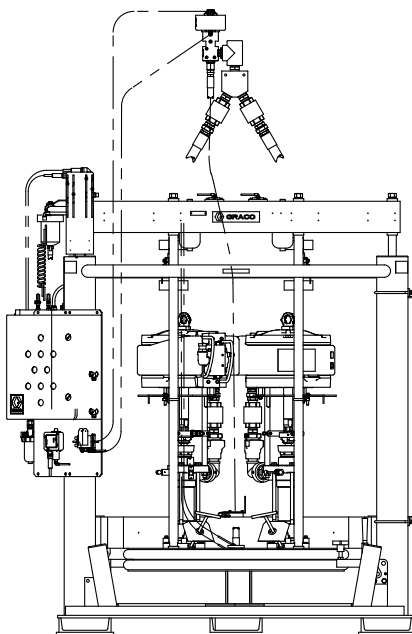

**Uni-Drum Left Hand Supply Unit**

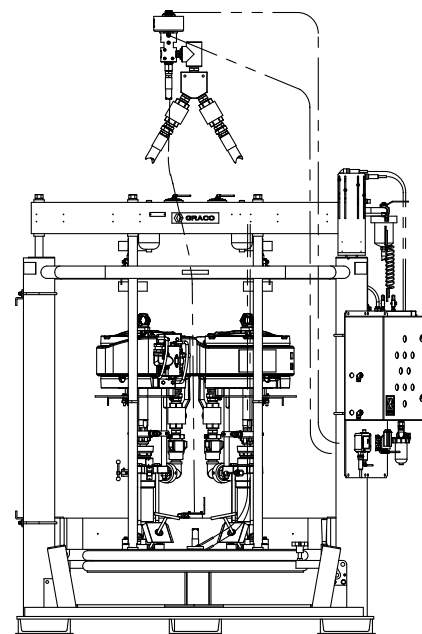

**Uni-Drum Right Hand Supply Unit**

# Contents

<b>Related Manuals</b> .....	<b>3</b>	<b>Operation</b> .....	<b>27</b>
<b>Models</b> .....	<b>4</b>	Prepare the Operator .....	27
<b>Warnings</b> .....	<b>6</b>	Overview .....	27
<b>Uncrating the System</b> .....	<b>9</b>	General Functional Description .....	27
<b>Overview</b> .....	<b>9</b>	System Startup .....	27
Installation Overview .....	9	System Operation .....	27
Operation Overview .....	9	Supply Unit Operation .....	27
<b>Component Identification</b> .....	<b>10</b>	System Shutdown .....	27
Uni-Drum Supply System with Customer Mounted Manifold and Drum Clamps .....	10	Flushing the System Before Initial Use .....	28
Uni-Drum Supply System with Machine Mounted Manifold .....	11	Adjusting the Drum Lid Holder Before Initial Use .....	28
Uni-Drum Supply System with Customer Mounted Manifold .....	12	Initial System Startup Procedure .....	29
Pneumatic Logic Panel .....	13	Changing Empty Drums .....	31
Junction Box Panel .....	16	Daily System Startup .....	33
General Description .....	18	System Shutdown .....	33
<b>Installation</b> .....	<b>20</b>	Stopping the System .....	33
Preparing the Site .....	20	Restarting the System .....	33
Selecting a Location for the Uni-Drum .....	20	<b>Pressure Relief Procedures</b> .....	<b>34</b>
Preparing to Install the Uni-Drum .....	20	Fluid Pressure Relief Procedure .....	34
Installing the Uni-Drum .....	21	Pneumatic Pressure Relief Procedure .....	35
Installing Drum Clamps .....	21	<b>Maintenance</b> .....	<b>36</b>
Installing Drum In Position Switch .....	21	Preventative Maintenance Schedule .....	36
Connecting Power to the Junction Box .....	22	Flushing the System .....	36
Grounding the System .....	24	Cleaning the System .....	36
Checking the Resistance Between the Pumps and the True Earth Ground .....	24	Wiper Lubrication .....	37
Connecting the Air Supply Lines to the Uni-Drum .....	25	<b>Junction Box Panel Service</b> .....	<b>38</b>
Connecting Output Hose to the Pumps .....	26	Indicator Light and Pushbutton Switch Removal .....	38
		Indicator Light and Pushbutton Switch Replacement .....	38
		Light Bulb Removal .....	38
		Light Bulb Replacement .....	38
		Fuse Removal .....	40
		Fuse Replacement .....	40
		Surge Suppressor Removal .....	40
		Surge Suppressor Replacement .....	40
		<b>PLC Interface Accessory Kit Service</b> .....	<b>42</b>
		Valve Assembly Bank .....	42
		Pressure Switch Assembly Replacement .....	42
		<b>Pneumatic Logic Panel Service</b> .....	<b>44</b>
		Filter/Element Replacement .....	44

<b>Ram Assembly Service</b> .....	<b>45</b>
Piston Rod Seal Service .....	45
Ram Piston Service .....	46
Low/Empty Limit Switch Replacement .....	47
Depressurization Valve (Ball Seat Applicator) Repair Procedure .....	48
Replacing Wipers .....	48
Pump Removal .....	50
<b>Recycling and Disposal</b> .....	<b>51</b>
End of Product Life .....	51
<b>Troubleshooting</b> .....	<b>52</b>
Ram Assembly Troubleshooting .....	52
Pump Troubleshooting .....	53
Air Motor Troubleshooting .....	54
Junction Box Panel Troubleshooting .....	54
Pneumatic Logic Panel Troubleshooting .....	55
<b>Parts</b> .....	<b>56</b>
248306, 249339, 253676, 258910 - 47:1 Left Hand Supply Unit .....	56
248307, 249340, 253677, 258911 - 47:1 Right Hand Supply Unit .....	56
249152, 249341, 234972, 258956 - 35:1 Left Hand Supply Unit .....	56
249153, 249342, 234973, 258957 - 35:1 Right Hand Supply Unit .....	56
24U642 - 35:1 Left Hand Supply Unit .....	60
24U643 - 35:1 Right Hand Supply Unit .....	60
232729, 47:1 Left Hand Supply Unit, with carbon steel pump .....	64
232839, 47:1 Left Hand Supply Unit, with stainless steel and ceramic pump .....	64
232730, 47:1 Right Hand Supply Unit, with carbon steel pump (shown) .....	64
232840, 47:1 Right Hand Supply Unit, with stainless steel and ceramic pump .....	64
246921, 47:1 Right Hand Supply Unit, with stainless steel pump .....	64
246922, 47:1 Left Hand Supply Unit, with stainless steel pump .....	64
255666, 47:1 Left Hand Supply Unit, with carbon steel pump .....	64
255665, 47:1 Right Hand Supply Unit, with carbon steel pump .....	64
24N914 - 35:1 Left Hand Supply Unit .....	67
24N915 - 35:1 Right Hand Supply Unit .....	67
Depressurization Kit, 241840 .....	71
Pneumatic Accessory Kit, 241837 .....	72
Low/Empty Limit Kit (for Uni-Drum Use), 24183973	

Proximity Switch Accessory Kit, 243488 .....	74
Follower Plate Assembly, 241891 and 243510 ..	75
PLC Pneumatic Logic Panel .....	77
PLC Interface Accessory Kit, 241838 and 24V775. 80	
Junction Box Panel, 195320 and 119773 .....	82
Follower Plate, 233041 .....	84
Safety Pin Maintenance Kit, 26B772 .....	86
Elevator Assembly, 241902 .....	88
<b>Recommended Spare Parts</b> .....	<b>90</b>
Spare Parts for Pump and Air Motor .....	90
Spare Parts for 47:1 and 35:1 Uni-Drum Supply Units .....	90
<b>Electrical Diagram</b> .....	<b>91</b>
Junction Box Panel .....	91
<b>Pneumatic Diagram</b> .....	<b>92</b>
<b>Technical Specifications</b> .....	<b>94</b>
Models 248306, 248307, 249339, 249340, 253676, 253677 .....	94
Models 249152, 249153, 249341, 249342, 234972, 234973, 258956, 258957, 24U642, 24U643, 25N914, 25N915 .....	95
Models 232729, 232730, 255665, 255666 .....	96
Models 232839, 232840, 246921, 246922 .....	97
<b>California Proposition 65</b> .....	<b>97</b>
<b>Graco Standard Warranty</b> .....	<b>98</b>

## Related Manuals

Manual in English	Description
308147	Carbon Steel Dura-Flo™ Pump 1800 with XL 10000™ Air Motor
308151	Carbon Steel Dura-Flo™ Pump 2400 with XL 10000™ Air Motor
308148	Stainless Steel Dura-Flo™ Pump 1800 with XL 10000™ Air Motor
308152	Stainless Steel Dura-Flo™ Pump 2400 with XL 10000™ Air Motor
334644	XL 10000™ Air Motor
3A1792	DV Series Dispense Valves
308213	XL 10000™ Air Motor

Dura-Flo™ and XL 10000™ are trademarks of Graco, Inc.

# Models

The Uni-Drum Supply Units listed below are covered in this manual. For specific pump information, refer to the chart in **Servicing the Pumps** on page 48.

Supply Unit Part No.	Pump	Ratio	Voltage	Max. Outlet Pressure	Max. Fluid Flow @ 60 cpm	Pump Manual	Platen Material
248306 (Left Hand)	XL 10000™, SST, silicone nitride	47:1	120V	4500 psi (31.0 MPa, 310 bar)	6.9 gpm (26 lpm)	308148	
248307 (Right Hand)	XL 10000™, SST, silicone nitride	47:1	120V	4500 psi (31.0 MPa, 310 bar)	6.9 gpm (26 lpm)	308148	
249339 (Left Hand)	XL 10000™, SST, silicone nitride	47:1	24V	4500 psi (31.0 MPa, 310 bar)	6.9 gpm (26 lpm)	308148	
249340 (Right Hand)	XL 10000™, SST, silicone nitride	47:1	24V	4500 psi (31.0 MPa, 310 bar)	6.9 gpm (26 lpm)	308148	
232729 (Left Hand)	XL 10000™, carbon steel	47:1	120V	4500 psi (31.0 MPa, 310 bar)	6.9 gpm (26 lpm)	308147	
232730 (Right Hand)	XL 10000™, carbon steel	47:1	120V	4500 psi (31.0 MPa, 310 bar)	6.9 gpm (26 lpm)	308147	
232839 (Left Hand)	XL 10000™, stainless steel	47:1	120V	4500 psi (31.0 MPa, 310 bar)	6.9 gpm (26 lpm)	308148	
232840 (Right Hand)	XL 10000™, stainless steel	47:1	120V	4500 psi (31.0 MPa, 310 bar)	6.9 gpm (26 lpm)	308148	
246921 (Left Hand)	XL 10000™, stainless steel	47:1	120V	4500 psi (31.0 MPa, 310 bar)	6.9 gpm (26 lpm)	308148	
246922 (Right Hand)	XL 10000™, stainless steel	47:1	120V	4500 psi (31.0 MPa, 310 bar)	6.9 gpm (26 lpm)	308148	
*253676 (Left Hand)	XL 10000™, stainless steel	47:1	120V	4500 psi (31.0 MPa, 310 bar)	6.9 gpm (26 lpm)	308148	
*253677 (Right Hand)	XL 10000™, stainless steel	47:1	120V	4500 psi (31.0 MPa, 310 bar)	6.9 gpm (26 lpm)	308148	
*258910 (Left Hand)	XL 10000™, stainless steel	47:1	24V	4500 psi (31.0 MPa, 310 bar)	6.9 gpm (26 lpm)	308148	
*258911 (Right Hand)	XL 10000™, stainless steel	47:1	24V	4500 psi (31.0 MPa, 310 bar)	6.9 gpm (26 lpm)	308148	
249152 (Left Hand)	XL 10000™, stainless steel	35:1	120V	3400 psi (23.1 MPa, 231 bar)	9.2 gpm (34.8 lpm)	308152	
249153 (Right Hand)	XL 10000™, stainless steel	35:1	120V	3400 psi (23.1 MPa, 231 bar)	9.2 gpm (34.8 lpm)	308152	
*234972 (Left Hand)	XL 10000™, stainless steel	35:1	120V	3400 psi (23.1 MPa, 231 bar)	9.2 gpm (34.8 lpm)	308152	
*234973 (Right Hand)	XL 10000™, stainless steel	35:1	120V	3400 psi (23.1 MPa, 231 bar)	9.2 gpm (34.8 lpm)	308152	











Supply Unit Part No.	Pump	Ratio	Voltage	Max. Outlet Pressure	Max. Fluid Flow @ 60 cpm	Pump Manual	Platen Material
*258956 (Left Hand)	XL 10000™, stainless steel	35:1	24V	3400 psi (23.1 MPa, 231 bar)	9.2 gpm (34.8 lpm)	308152	Carbon Steel, Painted
*258957 (Right Hand)	XL 10000™, stainless steel	35:1	24V	3400 psi (23.1 MPa, 231 bar)	9.2 gpm (34.8 lpm)	308152	
249341 (Left Hand)	XL 10000™, stainless steel	35:1	24V	3400 psi (23.1 MPa, 231 bar)	9.2 gpm (34.8 lpm)	308152	
249342 (Right Hand)	XL 10000™, stainless steel	35:1	24V	3400 psi (23.1 MPa, 231 bar)	9.2 gpm (34.8 lpm)	308152	
255666 (Left Hand)	XL 10000™, carbon steel	47:1	24V	4500 psi (31.0 MPa, 310 bar)	6.9 gpm (26 lpm)	308147	
255665 (Right Hand)	XL 10000™, carbon steel	47:1	24V	4500 psi (31.0 MPa, 310 bar)	6.9 gpm (26 lpm)	308147	
24U642 (Left Hand)	XL 10000™, stainless steel	35:1	24V	3400 psi (23.1 MPa, 231 bar)	9.2 gpm (34.8 lpm)	308152	
24U643 (Right Hand)	XL 10000™, stainless steel	35:1	24V	3400 psi (23.1 MPa, 231 bar)	9.2 gpm (34.8 lpm)	308152	
†*25N914 (Left Hand)	XL 10000™, stainless steel	35:1	120V	3400 psi (23.1 MPa, 231 bar)	9.2 gpm (34.8 lpm)	308152	
†*25N915 (Right Hand)	XL 10000™, stainless steel	35:1	120V	3400 psi (23.1 MPa, 231 bar)	9.2 gpm (34.8 lpm)	308152	









\* For LASD applications, outlet ball valves, fittings and manifolds are stainless steel. All other models, if equipped with ball valves, fittings, and a manifold, are carbon steel.

† Models are for conveyors by others (unit does not have guides or end stops). The end user is responsible for mounting drum clamps and drum in position sensor.



# Warnings

The following warnings are for the setup, use, grounding, maintenance, and repair of this equipment. The exclamation point symbol alerts you to a general warning and the hazard symbols refer to procedure-specific risks. When these symbols appear in the body of this manual or on warning labels, refer back to these Warnings. Product-specific hazard symbols and warnings not covered in this section may appear throughout the body of this manual where applicable.

 <h1 style="margin: 0;">WARNING</h1>	
   	<p><b>MOVING PARTS HAZARD</b></p> <p>Moving parts can pinch, cut or amputate fingers and other body parts.</p> <ul style="list-style-type: none"> <li>• Keep clear of moving parts.</li> <li>• Keep your hands away from the follower plate and the lip of the drum while the ram is operating.</li> <li>• Keep your hands away from the ram frame while the ram is operating.</li> <li>• Do not operate equipment with protective guards or covers removed.</li> <li>• Equipment can start without warning. Before checking, moving, or servicing equipment, follow the <b>Pressure Relief Procedure</b> and disconnect all power sources.</li> </ul>
    	<p><b>SKIN INJECTION HAZARD</b></p> <p>High-pressure fluid from gun, hose leaks, or ruptured components will pierce skin. This may look like just a cut, but it is a serious injury that can result in amputation. <b>Get immediate surgical treatment.</b></p> <ul style="list-style-type: none"> <li>• Do not spray without tip guard and trigger guard installed.</li> <li>• Engage trigger lock when not spraying.</li> <li>• Do not point gun at anyone or at any part of the body.</li> <li>• Do not put your hand over the spray tip.</li> <li>• Do not stop or deflect leaks with your hand, body, glove, or rag.</li> <li>• Follow the <b>Pressure Relief Procedure</b> when you stop spraying and before cleaning, checking, or servicing equipment.</li> <li>• Tighten all fluid connections before operating the equipment.</li> <li>• Check hoses and couplings daily. Replace worn or damaged parts immediately.</li> <li>• Use only Graco approved hoses. Do not remove any spring guard that is used to help protect the hose from rupture caused by kinks or bends near the couplings.</li> </ul>

 <h1 style="margin: 0;">WARNING</h1>	
 	<p><b>ELECTRIC SHOCK HAZARD</b></p> <p>This equipment must be grounded. Improper grounding, setup, or usage of the system can cause electric shock.</p> <ul style="list-style-type: none"> <li>• Turn off and disconnect power at main switch before disconnecting any cables and before servicing or installing equipment.</li> <li>• Connect only to grounded power source.</li> <li>• All electrical wiring must be done by a qualified electrician and comply with all local codes and regulations.</li> </ul>
   	<p><b>FIRE AND EXPLOSION HAZARD</b></p> <p>Flammable fumes, such as solvent and paint fumes, in <b>work area</b> can ignite or explode. Paint or solvent flowing through the equipment can cause static sparking. To help prevent fire and explosion:</p> <ul style="list-style-type: none"> <li>• Use equipment only in well-ventilated area.</li> <li>• Eliminate all ignition sources; such as pilot lights, cigarettes, portable electric lamps, and plastic drop cloths (potential static sparking).</li> <li>• Ground all equipment in the work area. See <b>Grounding</b> instructions.</li> <li>• Never spray or flush solvent at high pressure.</li> <li>• Keep work area free of debris, including solvent, rags and gasoline.</li> <li>• Do not plug or unplug power cords, or turn power or light switches on or off when flammable fumes are present.</li> <li>• Use only grounded hoses.</li> <li>• Hold gun firmly to side of grounded pail when triggering into pail. Do not use pail liners unless they are anti-static or conductive.</li> <li>• <b>Stop operation immediately</b> if static sparking occurs or you feel a shock. Do not use equipment until you identify and correct the problem.</li> <li>• Keep a working fire extinguisher in the work area.</li> </ul>
 	<p><b>EQUIPMENT MISUSE HAZARD</b></p> <p>Misuse can cause death or serious injury.</p> <ul style="list-style-type: none"> <li>• Do not operate the unit when fatigued or under the influence of drugs or alcohol.</li> <li>• Do not exceed the maximum working pressure or temperature rating of the lowest rated system component. See <b>Technical Specifications</b> in all equipment manuals.</li> <li>• Use fluids and solvents that are compatible with equipment wetted parts. See <b>Technical Specifications</b> in all equipment manuals. Read fluid and solvent manufacturer's warnings. For complete information about your material, request Safety Data Sheets (SDSs) from distributor or retailer.</li> <li>• Turn off all equipment and follow the <b>Pressure Relief Procedure</b> when equipment is not in use.</li> <li>• Check equipment daily. Repair or replace worn or damaged parts immediately with genuine manufacturer's replacement parts only.</li> <li>• Do not alter or modify equipment. Alterations or modifications may void agency approvals and create safety hazards.</li> <li>• Make sure all equipment is rated and approved for the environment in which you are using it.</li> <li>• Use equipment only for its intended purpose. Call your distributor for information.</li> <li>• Route hoses and cables away from traffic areas, sharp edges, moving parts, and hot surfaces.</li> <li>• Do not kink or over bend hoses or use hoses to pull equipment.</li> <li>• Keep children and animals away from work area.</li> <li>• Comply with all applicable safety regulations.</li> </ul>

# **WARNING**

	<p><b>SPLATTER HAZARD</b> Hot or toxic fluid can cause serious injury if splashed in the eyes or on skin. During blow off of platen, splatter may occur.</p> <ul style="list-style-type: none"> <li>• Use minimum air pressure when removing platen from drum.</li> </ul>
	<p><b>TOXIC FLUID OR FUMES HAZARD</b> Toxic fluids or fumes can cause serious injury or death if splashed in the eyes or on skin, inhaled, or swallowed.</p> <ul style="list-style-type: none"> <li>• Read Safety Data Sheets (SDSs) to know the specific hazards of the fluids you are using.</li> <li>• Store hazardous fluid in approved containers, and dispose of it according to applicable guidelines.</li> </ul>
	<p><b>PERSONAL PROTECTIVE EQUIPMENT</b> Wear appropriate protective equipment when in the work area to help prevent serious injury, including eye injury, hearing loss, inhalation of toxic fumes, and burns. Protective equipment includes but is not limited to:</p> <ul style="list-style-type: none"> <li>• Protective eyewear, and hearing protection.</li> <li>• Respirators, protective clothing, and gloves as recommended by the fluid and solvent manufacturer.</li> </ul>



# Uncrating the System

The Uni-Drum Supply System was carefully packaged for shipment by Graco. When the system arrives, perform the following procedure to uncrate the system.

## NOTICE

Moving the unit off of the pallet without following the uncrating procedure can damage the equipment.

To uncrate the system, perform the following steps:

1. Inspect the crate carefully for shipping damage. Contact the carrier promptly if damage is discovered.
2. Remove the plywood sides and top of the crate.
3. Inspect the contents carefully. There should not be any loose or damaged parts.
4. Compare the packing slip against all items included in the crate. Report any shortages or other inspection problems immediately.
5. Remove the band straps that hold the Uni-Drum to the pallet.
6. The Uni-Drum is ready for installation. Before installing the system, read the **General Description** section on page 18 to become familiar with the system components.

# Overview

## Installation Overview

The location of the Uni-Drum should allow for easy loading and unloading of the 300 gallon (1200 liter) magnadrum or other tote drums with either a forklift truck or pallet-jack hand truck.

The Uni-Drum Supply System must be leveled and mounted on a horizontal floor. An unlevelled condition can keep the Uni-Drum from operating properly.

Anchor the frame's four foot pads securely to the floor. The anchor bolts should be sized with sufficient safety factor to withstand the downward force of the follower plate and other objects that can push the frame off the floor.

## Operation Overview

The Uni-Drum is a supply system that evacuates fluids from a 300 gallon (1200 liter) magnadrum or other tote drums.

Each Uni-Drum includes two Graco air motors and displacement pumps, a ram assembly with a follower plate, a pneumatic layout panel that controls the air components and a junction box panel that connects with an electrical controller (supplied by the customer).

In short, the operator places the magnadrum inside the frame with the follower plate placed directly on top of the material. Locally, the system can be operated using the pneumatic layout panel. Remotely, the system can be operated using signals through the junction box panel.

Two displacement pumps evacuate material out of each magnadrum. After removing the empty drum from the system, the operator repeats the evacuation process when another drum is ready for evacuation.

# Component Identification

NOTE: FIG. 1, FIG. 2, and FIG. 3 shows the typical Uni-Drum Supply System equipped with XL 10000™ air motors.

## Uni-Drum Supply System with Customer Mounted Manifold and Drum Clamps

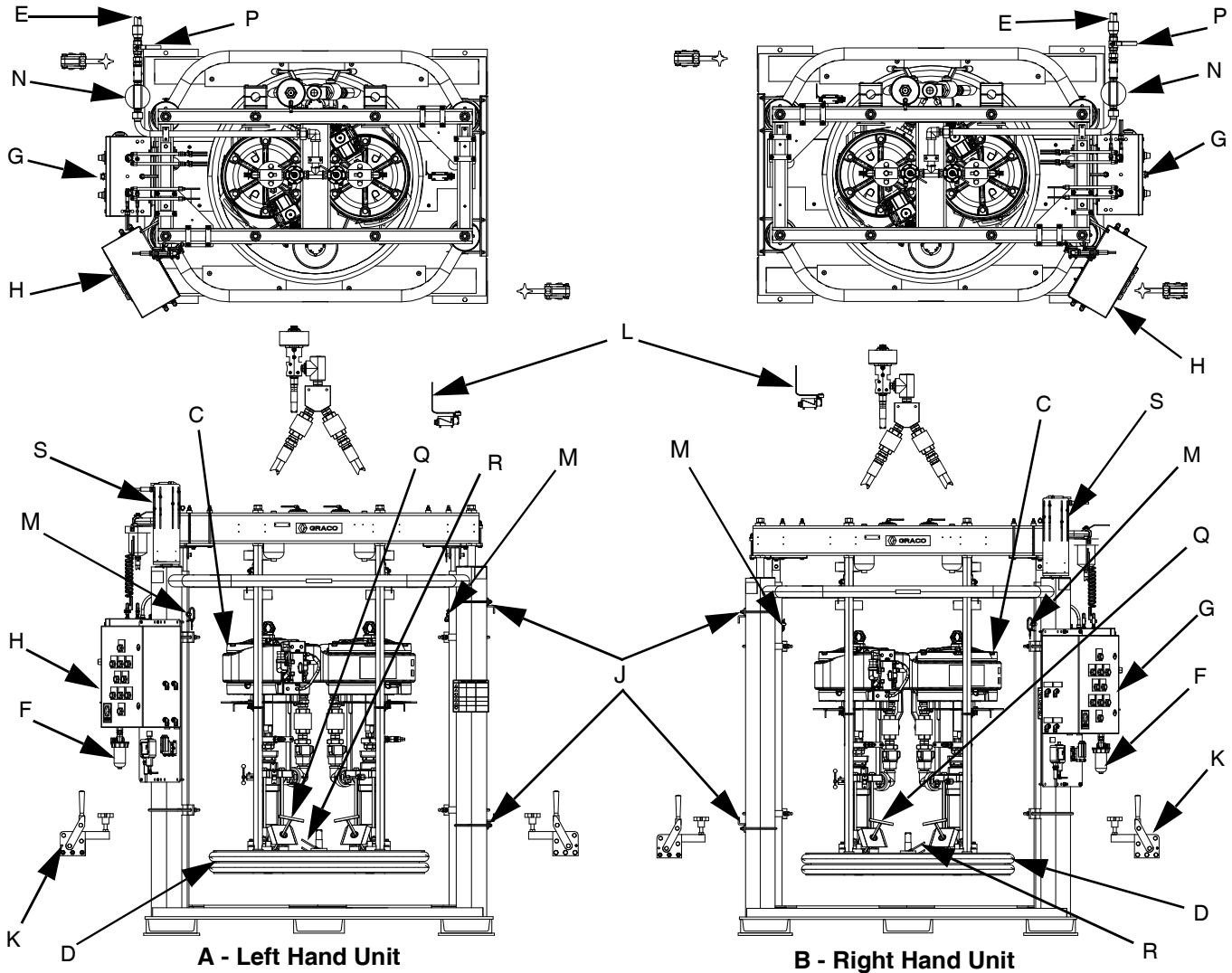

FIG. 1: Uni-Drum Supply System with XL 10000 Air Motors

**Key:**

- A Left Hand (LH) Supply Unit
- B Right Hand (RH) Supply Unit
- C Dura-Flo 1800 Pumps with XL 10000 Air Motors (2 units)
- D Follower Plate
- E Main Air Inlet
- F Pneumatic Panel Air Filter
- G Pneumatic Logic Panel
- H Junction Box Panel
- J Drum Lid Holders
- K Drum Clamps (installed by end user)

- L Drum in Position Switch (installed by end user)
- M Safety Pins
- N Main Air Filter
- P Main Air Shutoff Valve
- Q Bleed Port
- R Follower Vent
- S Limit Switches

**Left Hand Models**

25N914

**Right Hand Models**

25N915

# Uni-Drum Supply System with Machine Mounted Manifold

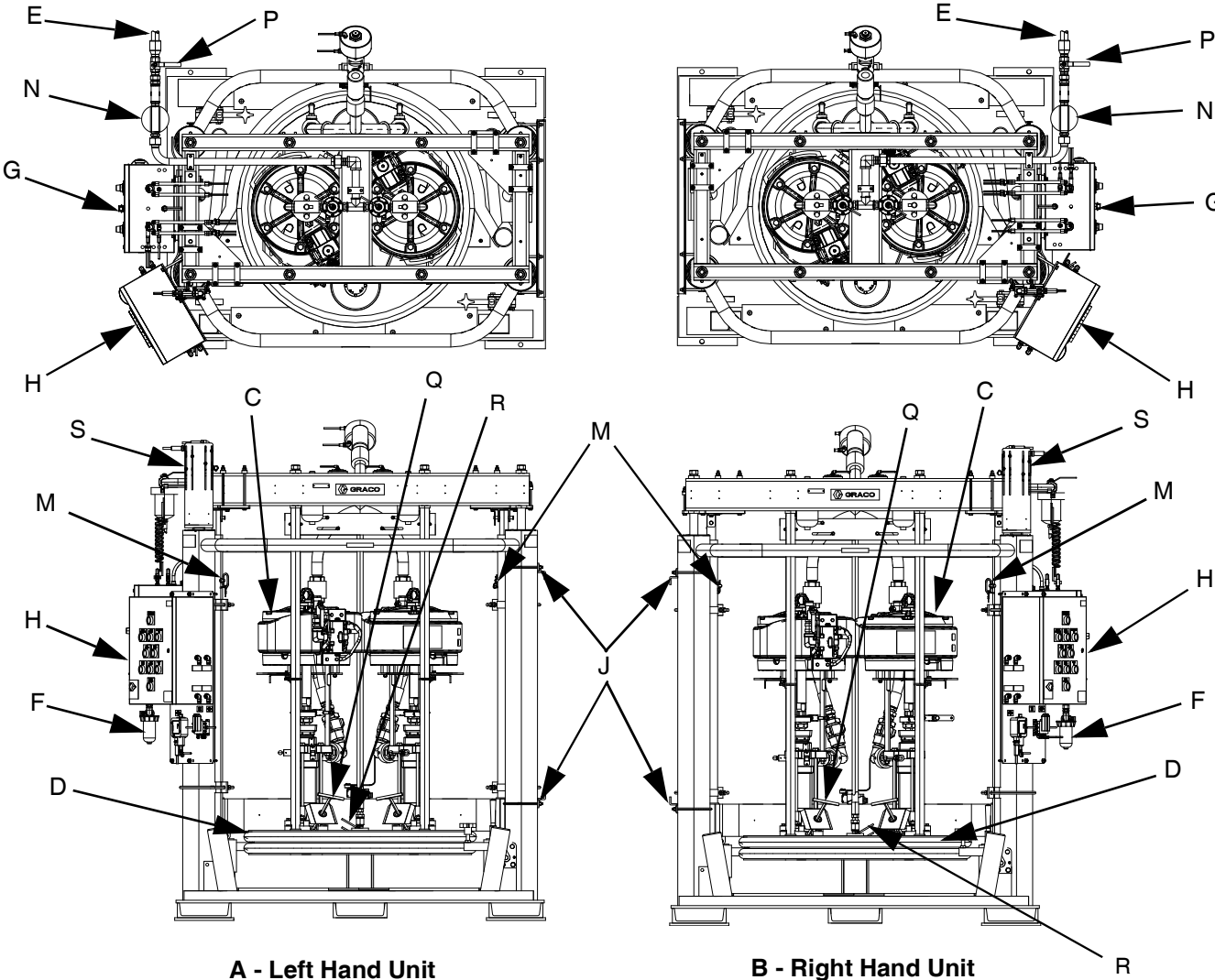

**FIG. 2: Uni-Drum Supply System with XL 10000 Air Motors**

**Key:**

- A Left Hand (LH) Supply Unit
- B Right Hand (RH) Supply Unit
- C Dura-Flo 1800 Pumps with XL 10000 Air Motors (2 units)
- D Follower Plate
- E Main Air Inlet
- F Pneumatic Panel Air Filter
- G Pneumatic Logic Panel
- H Junction Box Panel
- J Drum Lid Holders
- M Safety Pins
- N Main Air Filter
- P Main Air Shutoff Valve
- Q Bleed Port
- R Follower Vent
- S Limit Switches

Left Hand Models	Right Hand Models
232729	232730
232839	232840
246921	246922
255666	255665
24H017	24H016
24U642	24U643

## Uni-Drum Supply System with Customer Mounted Manifold

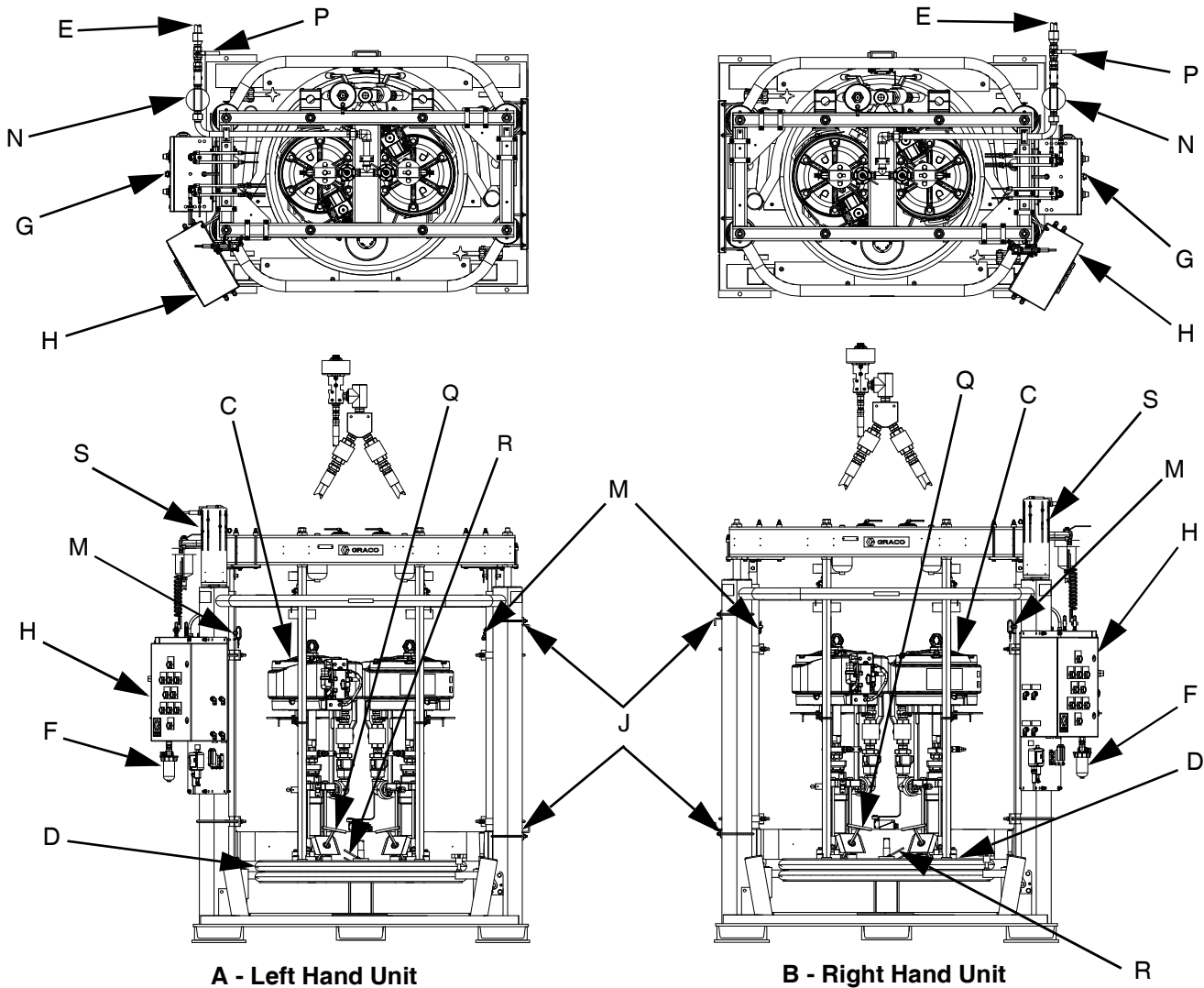

**FIG. 3: Uni-Drum Supply System with XL 10000 Air Motors**

<b>Key:</b>	<b>Left Hand Models</b>	<b>Right Hand Models</b>
A Left Hand (LH) Supply Unit	248306	248307
B Right Hand (RH) Supply Unit	249339	249340
C Dura-Flo 1800 Pumps with XL 10000 Air Motors (2 units)	253676	253677
D Follower Plate	258910	258911
E Main Air Inlet	249152	249153
F Pneumatic Panel Air Filter	249341	249342
G Pneumatic Logic Panel	234972	234973
H Junction Box Panel	258956	258957
J Drum Lid Holders		
M Safety Pins		
N Main Air Filter		
P Main Air Shutoff Valve		
Q Bleed Port\		
R Follower Vent		
S Limit Switches		

# Pneumatic Logic Panel

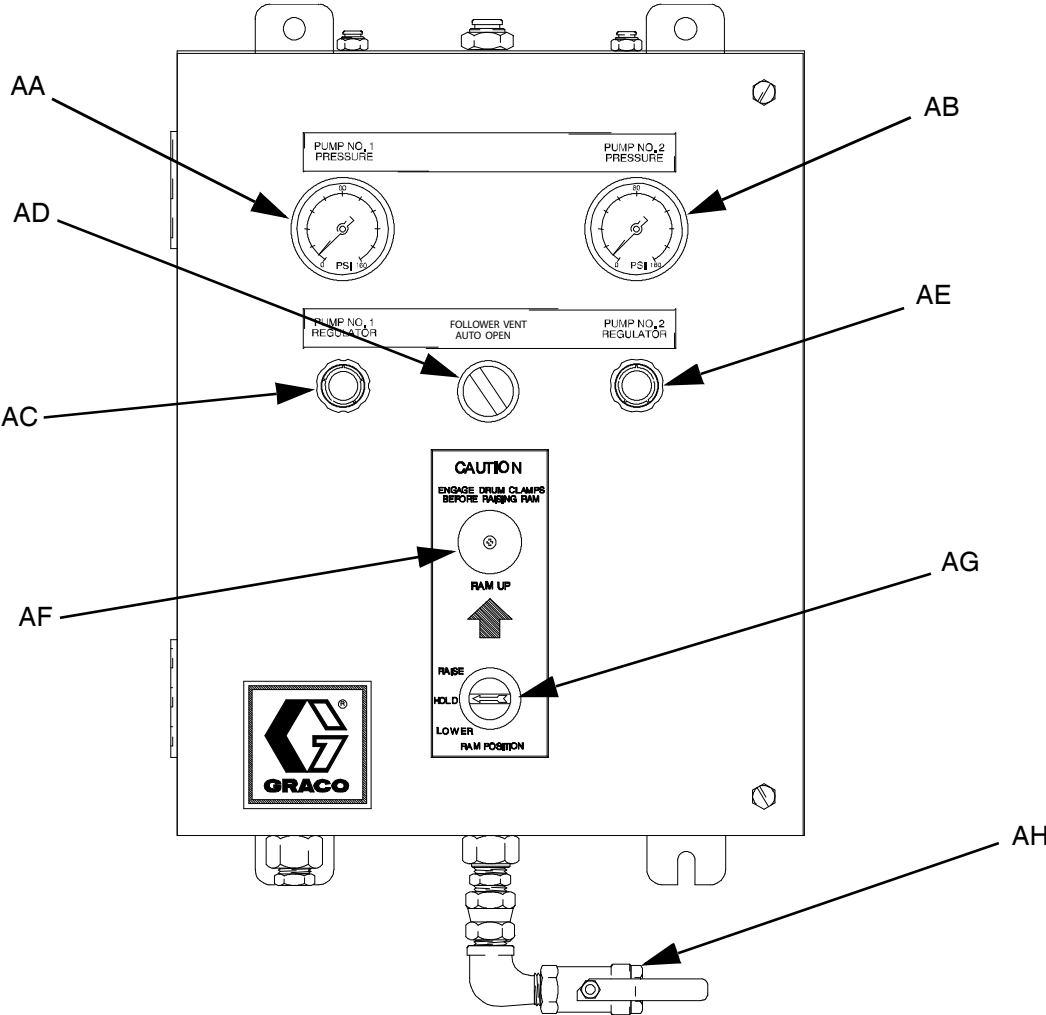

24K172 Panel Shown

FIG. 4: Pneumatic Logic Panel

T10202

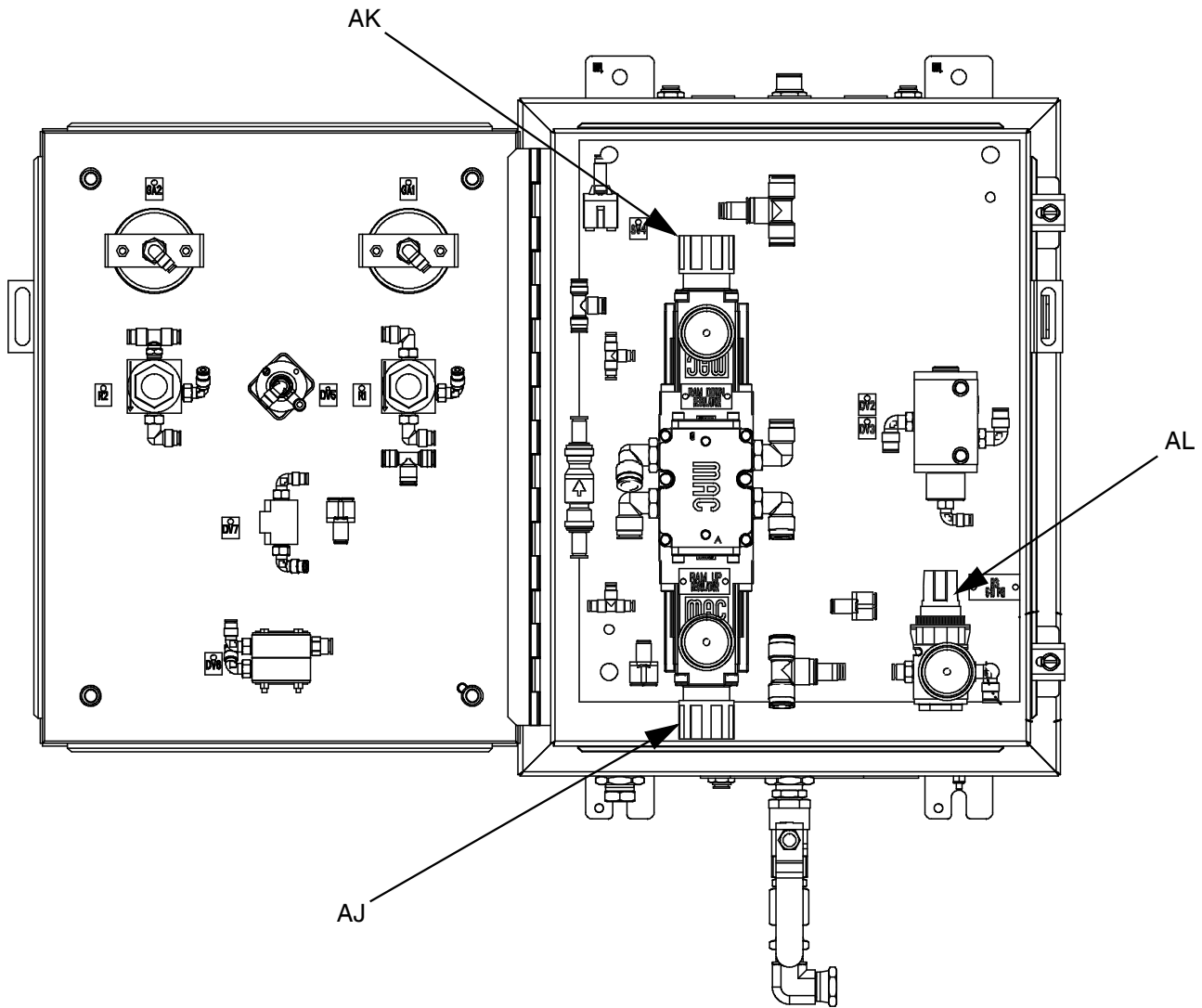

**FIG. 5: Pneumatic Logic Panel Interior**

## Pneumatic Logic Panel Switches and Indicators

Use the table and FIG. 4 when operating the switches and reading the indicators on the Pneumatic Logic Panel (G).

Ref.	Button/Switch/Guage		What it Does
AA	PUMP NO. 1 PRESSURE Air Gauge		Indicates the air outlet pressure setting from Pump No. 1.
AB	PUMP NO. 2 PRESSURE Air Gauge		Indicates the air outlet pressure setting from Pump No. 2.
AC	PUMP NO. 1 REGULATOR Control Knob		Controls Pump speed and outlet pressure by adjusting the air pressure to Pump No. 1.
AD	FOLLOWER VENT Directional Valve		Opens and closes the vent that relieves air pressure from the Follower Plate (D).
AE	PUMP NO. 2 REGULATOR Control Knob		Controls Pump speed and outlet pressure by adjusting the air pressure to Pump No. 2.
AF	RAM UP Pushbutton		Raises the Follower Plate (D) when the RAM POSITION Switch (AG) is set to RAISE.
AG	RAM POSITION Switch	RAISE	Allows the Follower Plate (D) to raise.
		HOLD/NEUTRAL	Holds the Follower Plate (D) in the current position.
		LOWER	Lowers the Follower Plate (D).
AH	Panel Air Inlet Valve		Opens air supply line to the Pneumatic Logic Panel (G).
AJ	RAM UP Air Regulator		Controls the air pressure used to raise the ram assembly.
AK	RAM DOWN Air Regulator		Controls the air pressure used to lower the ram assembly.
AL	R3 Regulator		Maintains air pressure on top of the ram cylinders to prevent the Follower Plate (D) from raising too quickly out of the drum.

# Junction Box Panel

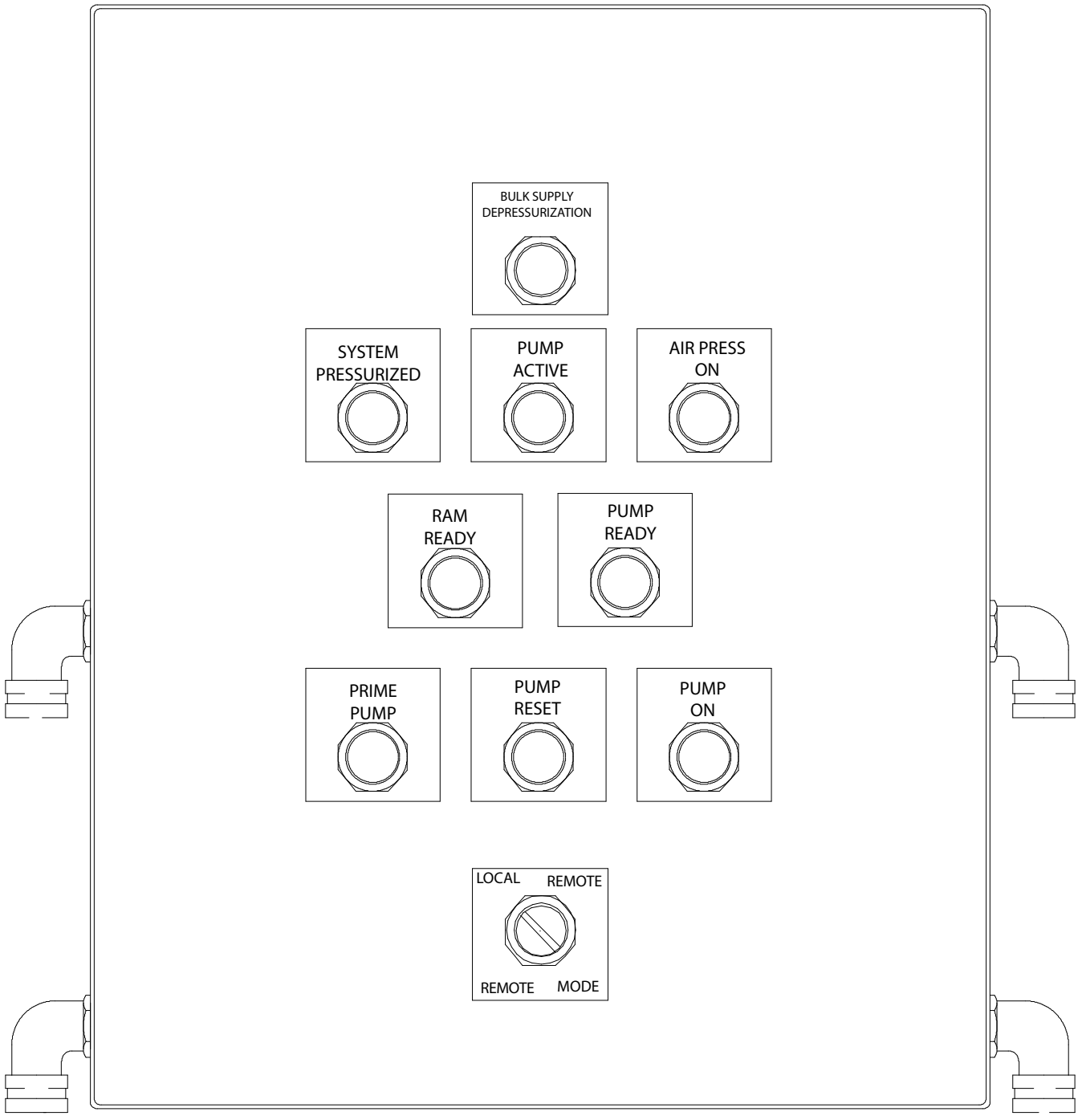

*195320 and 119773 Panel Shown*

**FIG. 6: Junction Box Panel**



## Junction Box Panel Switches and Indicators

Use the table and FIG. 6 when operating the switches and reading the indicator on the Junction Box Panel.

Button/Switch	What it Does
PRIME PUMP Pushbutton	<ul style="list-style-type: none"> <li>Primes both displacement Pumps with material, making the Pumps ready to operate.</li> <li>Lights PUMP READY Light.</li> </ul>
PUMP RESET Pushbutton	<ul style="list-style-type: none"> <li>Restarts the Pumps after the Pumps were turned off.</li> <li>Lights PUMP ACTIVE Light</li> </ul>
PUMP ON Pushbutton	<ul style="list-style-type: none"> <li>Activates the Pumps.</li> <li>Deactivates the Pumps.</li> </ul>
BULK SUPPLY DEPRESSURIZATION Pushbutton	<ul style="list-style-type: none"> <li>Opens the depressurization valve to lower the fluid supply pressure.</li> </ul>
LOCAL REMOTE Switch	<ul style="list-style-type: none"> <li>Places fluid dispensing system into Automatic or Manual mode.</li> </ul>

Indicator	Indicator Light is	Meaning
SYSTEM PRESSURIZED Light	ON	System is pressurized.
	OFF	System is depressurized.
PUMP ACTIVE Light	ON	Pumps are active; air is available to the Pumps.
	OFF	Pumps are inactive; air is unavailable to the Pumps.
AIR PRESS ON Light	ON	Air pressure is available to the Pumps for use.
	OFF	Air pressure is not available to the Pumps for use.
RAM READY Light	ON	Follower Plate (D) is ready for use.
	OFF	Follower Plate (D) is not ready for use.
PUMP READY Light	ON	Pumps are primed and ready to use.
	OFF	Pumps are not ready to use.

## General Description

A general description of the Uni-Drum Supply System helps the installers and operators become familiar with the system components. Contact your Graco distributor for help in choosing accessories to suit your particular needs.

Before you install the system, you should be familiar with the parts described in the following paragraphs.

## System Components

See FIG. 1 on page 10.

- **Uni-Drum Supply Unit (A,B)** is usually setup to alternate the material supply operation between the left hand (LH) and right hand (RH) Supply Units, which is accomplished using a combination of robotic software programming (provided by others) and manual operators. Drum changeovers occur after the Follower Plate (D) has reached its preset low limit level in the drum. Alternating between Supply Units eliminates the downtime that is usually expended unloading an empty drum and reloading a full drum.
  - LH Supply Unit (A) accommodates one 300 gallon (1200 liter) drum. The LH Supply Unit has a local Pneumatic Logic Panel (G) and Junction Box Panel (H).
  - RH Supply Unit (B) accommodates one 300 gallon (1200 liter) drum. The RH Supply Unit has a local Pneumatic Logic Panel (G) and Junction Box Panel (H).
- The two **Dura-Flo™ 1800 Pumps (C)** have XL 10000™ air motors. The Pumps evacuate material from the drum.
- **The Follower Plate (D)** is connected to the ram assembly and is designed to apply an even amount of pressure to the material in the drum. With the Follower Plate in its raised position, the operator moves a drum inside the frame. The Follower Plate is lowered directly on top of the material in the drum. When pressure is applied to the Follower Plate, the material is pumped out of the drum through hoses, which are attached to the Pump outlet ports. When the drum is empty, the operator raises the Follower Plate, removes the empty drum. The process is repeated when another drum is ready to be unloaded.

- **Pneumatic Panel Air Filter (F)** filters air to the Pneumatic Logic Panel (G). The 5 micron filter removes particles, such as dust, moisture, foreign matter and other contaminants from the compressed air.
- The **Safety Pins (M)** are used to keep the ram from lowering while in the fully raised position during drum changes or maintenance of the supply system.
- **Main Air Shutoff Valve (P)** is used to open or shutoff the air supply to the entire Supply Unit (A,B).

## Pneumatic Logic Panel (G)

See FIG. 4 on page 13 and FIG. 5 on page 14.

The Pneumatic Logic Panel (G) includes the following system components. For more information, refer to the **Pneumatic Diagram** on page 92.

- PUMP NO. 1 REGULATOR Control Knob (AC) controls Pump speed and outlet pressure for Pump No. 1 by adjusting the air pressure to the Pump.
- PUMP NO. 1 PRESSURE Air Gauge (AA) displays the amount of air pressure supplied to Pump No. 1.
- PUMP NO. 2 REGULATOR Control Knob (AE) controls Pump speed and outlet pressure for Pump No. 2 by adjusting the air pressure to the Pump.
- PUMP NO. 2 PRESSURE Air Gauge (AB) displays the amount of air pressure supplied to Pump No. 2.
- FOLLOWER VENT Directional Valve (AD) is activated to open the vent to relieve container pressure.
- RAM UP Pushbutton (AF) turns on air pressure to raise the Follower Plate (D) when used in conjunction with the RAM POSITION Switch (AG).
- The RAM POSITION Switch (AG) performs the following three functions:
  - Place the switch in the RAISE position to raise the Follower Plate (D).
  - Place the switch in the HOLD/NEUTRAL position to hold the Follower Plate (D) in the current position.
  - Place the switch in the LOWER position to lower the Follower Plate (D).

## Junction Box Panel (H)

See FIG. 6 on page 16.

The Junction Box Panel (H) includes the following system components. For additional information, refer to the **Electrical Diagram** on page 91.

- **SYSTEM PRESSURIZED** Light is lit when air pressure is supplied to the system; the light is extinguished when the air supply is depressurized. This occurs after the **PUMP ON** Pushbutton has been pushed and the Pumps turned on.
- **PUMP ACTIVE** Light is lit when the air supply is turned on to the Pumps; the light is extinguished when the Pumps are inactive, thus turned off. This is activated by the **PUMP ON** Pushbutton.
- **AIR PRESS ON** Light is lit when air pressure to the system is turned on; the light is extinguished when air pressure to the system is shutoff.
- **RAM READY** Light is lit when the drum is in position; the light is extinguished when the drum is not in position.
- **PUMP READY** Light is lit when the Pumps are primed and ready for operation; the light is extinguished when the Pumps are not ready for operation.
- **PRIME PUMP** Pushbutton turns on the Pumps, for priming. When the Pumps are primed, the **PUMP READY** Light turns on. The switch is not used when the **PUMP READY** Light is lit. The **PUMP ACTIVE** Light will blink.
- **PUMP RESET** Pushbutton resets the Pumps to an active state. When the Pumps are reset, the **PUMP ACTIVE** Light turns off. The switch is not used when the **PUMP ACTIVE** Light is lit. The **PUMP READY** Light is on.
- **PUMP ON** Pushbutton turns the Pumps on and off. When the Pumps are turned on, the **PUMP ACTIVE** Light also turns on. When the Pumps are turned off, the **PUMP ACTIVE** Light also turns off.
- **BULK SUPPLY DEPRESSURIZATION** Pushbutton opens the depressurization valve to lower the fluid pressure.
- **LOCAL REMOTE** Switch puts the system into or out of automatic operation.

# Installation



The Uni-Drum Supply System is supplied with every major component attached and weighs approximately 3950 lb (1792 kg). The Uni-Drum Supply System should never be moved or lifted by one person. To avoid serious injury or equipment damage, engage an adequate number of personnel and use a forklift, hand truck, and support devices, such as a hoist when moving and installing the Uni-Drum.

## NOTICE

Exercise care when the system is being moved to its installed location. Jarring, dropping, or tilting the frame while it is being lifted or moved can result in damage to the system.

The installation procedures in this section are intended to serve as a guide for installing the Uni-Drum Supply System. If you need more information, contact your Graco distributor.

**NOTE:** When raising and lowering the Ram, be sure that the unit is unobstructed overhead to avoid interference with other objects.

## Preparing the Site

Ensure that you have an adequate compressed air supply. Refer to the applicable instruction manual listed in **Related Manuals** on page 3 to find the air consumption of your Pump. Approximately 450 cfm at 80 psi is required to operate the Pumps at the maximum rate.

Keep the site clear of any obstacles or debris that could interfere with the installer's and operator's movement.

## Selecting a Location for the Uni-Drum

Refer to **Technical Specifications** on page 94 for ram mounting and clearance dimensions.

When selecting a location for the Uni-Drum, keep the following in mind:

1. There should be sufficient space for installing, servicing, and using the equipment.
  - Select an accessible location for the system. There must be sufficient space around the system for maintenance.
  - Select a convenient location for the equipment. Check that there is sufficient overhead clearance for the Pump and ram when the ram is in the fully raised position. Make sure the Air Regulators (AC, AE) for the Pumps (C) and Follower Plate (D) are fully accessible.
  - Make sure the air source for the PLC control panel and shutoff valves are fully accessible.
  - Make sure there is easy and safe access to an appropriate pneumatic source. Graco recommends a minimum of 3 feet (0.91 m) of open space in front of the Pneumatic Logic Panel (G).
2. Make sure that you will be able to level the base of the ram using metal shims.

## Preparing to Install the Uni-Drum

Before installing the system:

- See component manuals for specific data on component requirements. Data presented here pertains to the system only.
- Have all system and subassembly documentation available during installation.
- Be sure that all non-Graco supplied hoses are adequately sized and pressure-rated to meet the system requirements.

## Installing the Uni-Drum

To install the Uni-Drum, follow the procedure below. Refer to **Technical Specifications** on page 94 for ram mounting and clearance dimensions.

1. Using equipment such as a forklift or handtruck, move the Uni-Drum into place on the floor. Remove the shipping pallet.
2. Level the Uni-Drum, using metal shims.
3. Using the holes in the base as a guide, drill holes for 13 mm (1/2 in.) anchors.
4. Bolt the Uni-Drum to the floor using anchors that are long enough to prevent the unit from tipping.

## Installing Drum Clamps

**NOTE:** Drum Clamps (K) are only used with 25N914 and 25N915 Uni-Drum models. See **Component Identification** on page 10.

Two Drum Clamps (K) are provided with the system to be installed prior to system operation. The clamps hold the drum in place while removing the Follower Plate (D). The end user must locate and install the clamps in a manner that will hold the drum to the frame evenly.

## Installing Drum In Position Switch

**NOTE:** The Drum In Position Switch (L) is only used with 25N914 and 25N915 Uni-Drum models. See **Component Identification** on page 10.

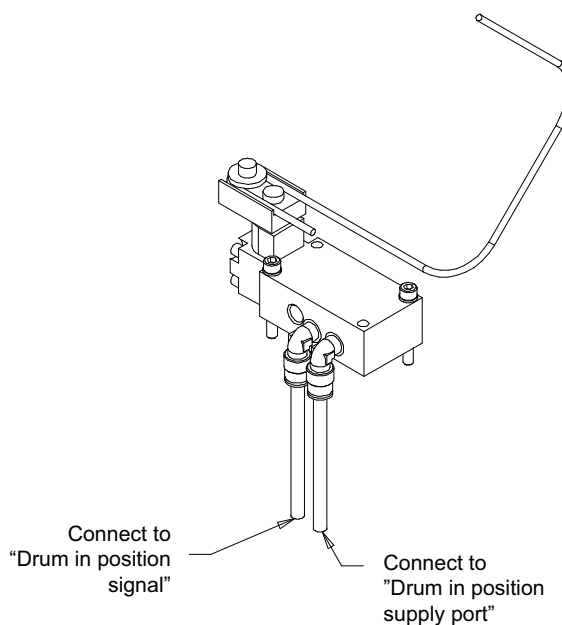

A Drum In Position Switch (L) is provided with the system to be installed prior to system operation. The Drum In Position Switch indicates that the drum is loaded. The end user must locate and install the switch in a location that will indicate the drum is in position. Connect the switch as shown below to the Pneumatic Logic Panel (G).



**FIG. 7: Uni-Drum Supply Switch**

## Connecting Power to the Junction Box

Perform the following procedure to connect the power to the Junction Box Panel (H).

				
All electrical wiring must be done by a qualified electrician and comply with all local codes and regulations.				

<b>NOTICE</b>
If power and grounding connections are not done properly, the equipment may be damaged and the warranty will be voided.

Have a qualified electrician connect the Junction Box Panel (H) to a grounded electrical source and disconnect that has the following required service ratings:

	Hz	Phase	Circuit Breaker
<b>120 Vac Models</b>	50/60	1	5 Amp
<b>24 Vdc Models</b>	-	-	

To connect the Junction Box Panel (H) to the electrical source, perform the following steps:

1. Shut off system power at the main circuit breaker.
2. Remove the cover from the Junction Box Panel (H).
3. Locate the PLC power terminals KS102 and KS100 on the terminal strip inside the Junction Box Panel (H). See FIG. 8. For more information, refer to **Electrical Diagram** on page 91.
4. Using the upper wire duct on the left-hand side of the Junction Box Panel (H), string two 14 AWG wires inside the box from the electrical power source.
5. Connect a ground wire to the ground lug shown in FIG. 8 on page 23.
6. Connect the two 14 AWG wires to power terminals KS102 (L1, hot) and KS100 (L2, neutral) in the Junction Box Panel (H).

7. Seal the area where wires entered the Junction Box Panel (H).
8. Replace the cover on the Junction Box Panel (H).

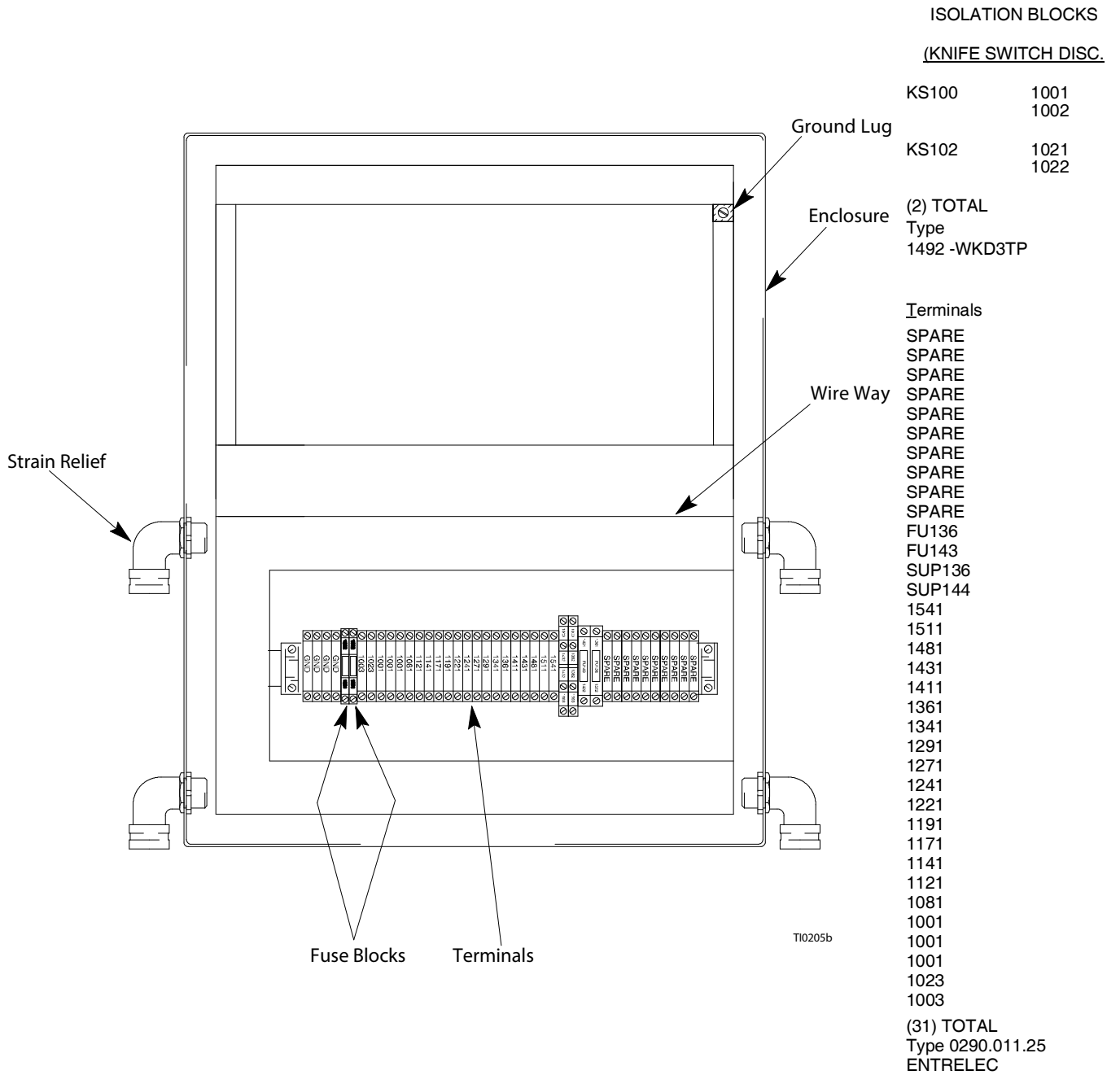





Fig. 8

## Grounding the System

				
<p>The equipment must be grounded to reduce the risk of static sparking and electric shock. Electric or static sparking can cause fumes to ignite or explode. Improper grounding can cause electric shock. Grounding provides an escape wire for the electric current.</p>				

**Junction Box Panel (H):** connect the electrical supply ground wire to the ground lug. See **Connecting Power to the Junction Box** on page 22.

**Pump:** use a ground wire and clamp. Verify that the ground screw (GS) is attached and tightened securely to the air motor. Connect the clamp (U) of the static ground cable assembly to a true earth ground. For a ground wire and clamp, order Part No. 244524.

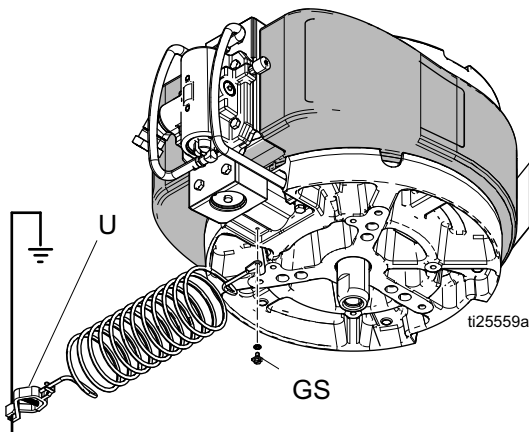

FIG. 9

**Air and fluid hoses:** use only electrically conductive hoses.

**Air compressor:** follow manufacturer's recommendations.

**Spray gun / Dispense valve:** ground through connection to a properly grounded fluid hose and Pump.

**Fluid supply container:** follow local code.



**Object being sprayed:** follow local code.

**Solvent pails used when flushing:** follow local code. Use only conductive metal pails, placed on a grounded

surface. Do not place the pail on a nonconductive surface, such as paper or cardboard, which interrupts grounding continuity.

**To maintain grounding continuity when flushing or relieving pressure:** hold metal part of the spray gun firmly to the side of a grounded metal pail, then trigger the gun.

## Checking the Resistance Between the Pumps and the True Earth Ground

				
<p>To reduce the risk of fire, explosion, or electric shock, the resistance between the Supply Unit components and true earth ground must be less than 1.0 ohms.</p>				

Check the resistance between each Pump and the true earth ground. If the resistance is greater than 1.0 ohms, a different ground site may be required. Do not operate the system until the problem is corrected.

**NOTE:** Use a meter that is capable of measuring resistance at this level.







## Connecting the Air Supply Lines to the Uni-Drum

Perform the following procedure to connect the input air supply lines to the Uni-Drum Supply System.

### Connecting Air Supply Lines to the Supply Units

To connect the main air supply line to the LH and RH Supply Units (A, B), perform the following steps:

			
<p>To reduce the risk of overpressurizing your system, which could result in component rupture and cause serious injury due to splashing and skin injection, never exceed the specified maximum incoming air pressure to the Pumps (see the <b>Technical Specifications</b> on page 94).</p>			

Have a qualified technician connect both Supply Units to an air supply source that has the following required ratings:

Description	Requirements
Inlet Port Size:	1 in. npt(f)
Air Volume:	450 cfm (maximum)
Input Air:	80 psi (5.5 bar, 0.55 MPa)

1. Check the air supply to ensure that it is properly sized and pressure-rated for this system.
2. Connect the air supply line to the 1 in. npt Main Air Inlet (E).

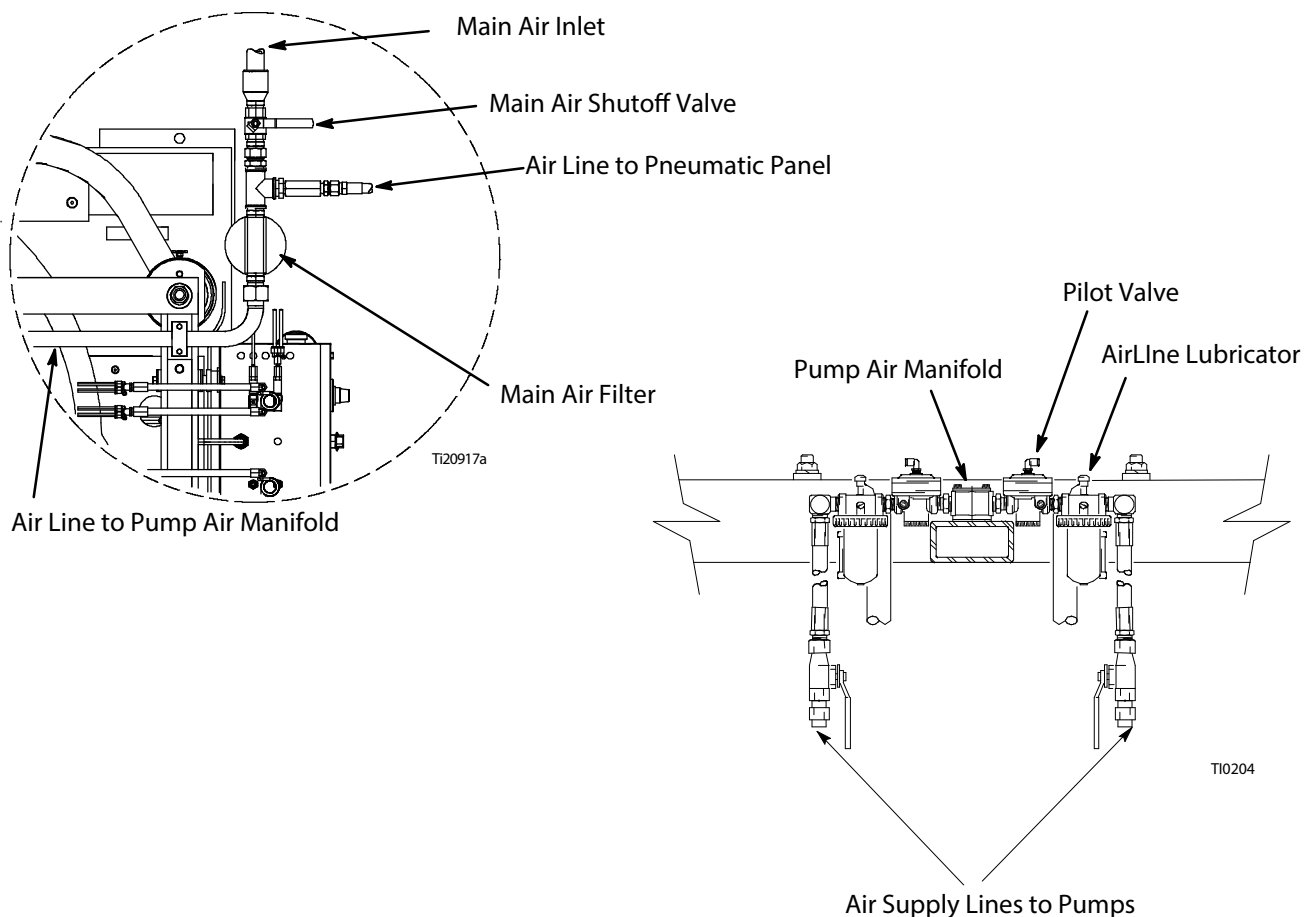

FIG. 10

## Connecting Output Hose to the Pumps

This procedure describes how to connect the fluid output hoses to the two Pumps. It is the customer's responsibility to have the fluid supply hose already installed and ready for connection to the Pumps.

**NOTE:** For more information about the Pumps, see **Related Manuals** on page 3 for the Pump instruction manuals.

### NOTICE

There must be a minimum of 10 feet (3 m) of fluid supply hose on the outlet to prevent damage to the unit.

**NOTE:** The fluid supply hose must move freely without kinking when the Pumps move up and down.

Check the fluid supply hose to ensure it is properly sized and pressure-rated for this system. Use only electrically conductive hoses. The fluid supply hose should have spring guards on both ends. Connect the fluid supply hose to the fluid manifold outlet.

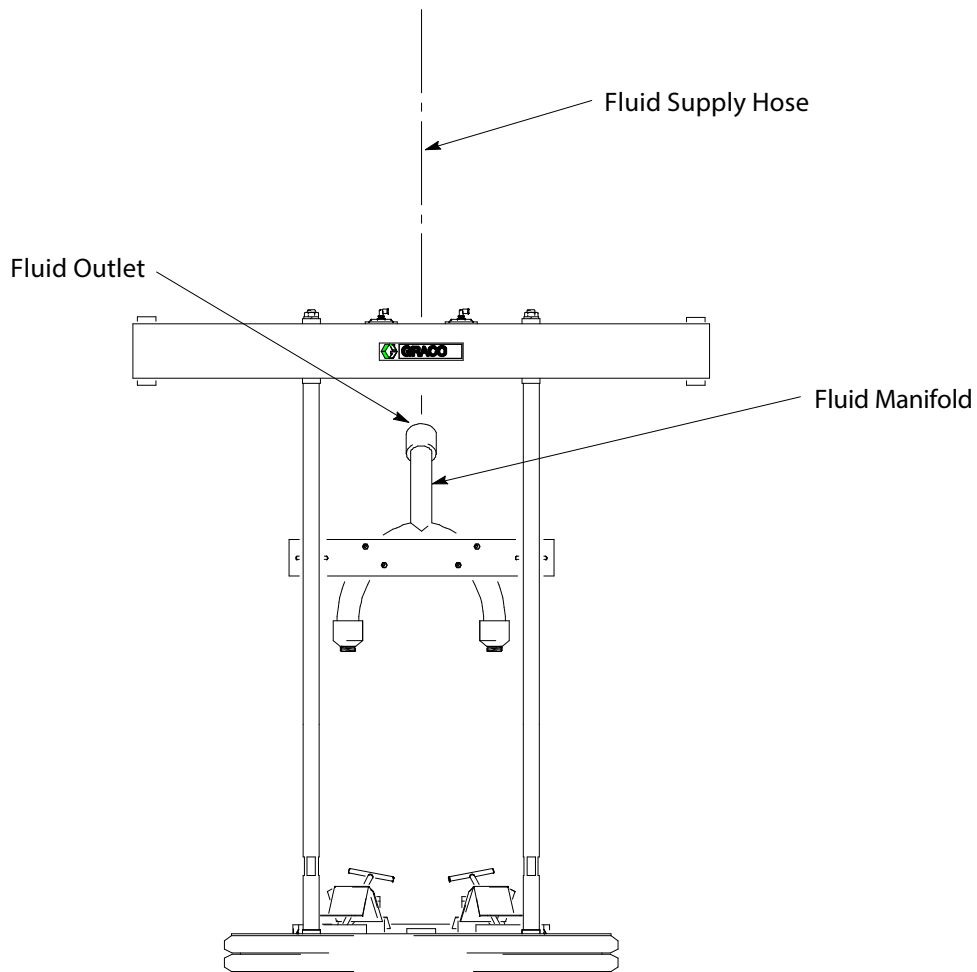

TI0139

FIG. 11

# Operation

## Prepare the Operator

All persons who operate the equipment must be trained in the safe, efficient operation of all system components as well as the proper handling of all fluids. All operators must thoroughly read all instruction manuals, tags, and labels before operating the equipment.

## Overview

The Uni-Drum Supply System uses two air driven reciprocating Pumps (C) on the LH Supply Unit (A) and two air driven reciprocating Pumps (C) on the RH Supply Unit (B). Each Supply Unit Pumps material from a 300 gallon (1200 liter) drum.

## General Functional Description

The LH and RH Supply Units can operate at the same time or as independent units. Generally, the Uni-Drum Supply System is setup to operate as redundant units. This means that the RH Supply Unit is held in reserve on standby until the drum underneath the LH Supply Unit has been emptied, and vice versa.

Operating a redundant system allows the operator to maintain a continuous supply of material without interruption. The operator is afforded sufficient time to replace an empty drum at one Supply Unit while the drum at the other Supply Unit is being emptied.

## System Startup

There are a series of steps that must be followed in sequential order to startup the system.

## System Operation

Depending upon the system setup, at any time during operation, the operator can:

- Stop the Pumps and relieve ram pressure at the LH Supply Unit (A).
- Stop the Pumps and relieve ram pressure at the RH Supply Unit (B).
- Shutdown the system.

At the Supply Unit (A, B), the Follower Plate (D) must be raised to load the drum into the Supply Unit. The Follower Plate (D) is lowered by the operator directly into the drum. The Pumps are turned on, the Follower Plate (D) is pressurized, and material is pumped from the drum through the outlet ports on the Pumps via a supply hose to one or more targeted applications.

## Supply Unit Operation

The Uni-Drum Supply System can be setup to alternate between the LH and RH Supply Units. This dual supply system setup (controlled by others) virtually eliminates material replenishment downtime.

The Uni-Drum Supply System allows the operator to load the material drum into the RH Supply Unit (B) while the LH Supply Unit (A) drum is being emptied. When the Supply Unit changeover occurs, the operator unloads the empty drum at the LH Supply Unit (A) while the RH Supply Unit (B) drum is being emptied. The cycle is repeated as many times as needed.

## System Shutdown

For system shutdown, the operator turns off the Pumps (C) and depressurizes the system. Depending upon the type of material, the operator may choose to raise the Follower Plate (D) from the drum or keep the Follower Plate (D) lowered in the drum to prevent the material from being contaminated. Some materials will harden or congeal when exposed to air or used past their shelf life. Material should be kept covered when it is not being used and uncovered when it is ready to use.

## Flushing the System Before Initial Use

Flushing the system before its initial use can prevent material contamination, which may cause the material to fail or perform poorly.

The equipment was tested with lightweight oil, which is left in the fluid passages to protect parts. To avoid contaminating your fluid with oil, flush the equipment with a compatible solvent before using the equipment.



To avoid fire and explosion, always ground equipment and waste container. To avoid static sparking and injury from splashing, always flush at the lowest possible pressure.

### NOTICE

There must be a minimum of 10 feet (3 m) of fluid supply hose on the outlet to prevent damage to the unit.

To flush the system, perform the following procedure:

1. Select the material for the initial material load.
2. Verify whether the factory-test oil and the initial material load are compatible:
  - a. If the two substances are compatible, omit the remaining steps in this procedure and perform the **Initial System Startup Procedure** on page 29.
  - b. If the two substances are incompatible, perform the remaining steps in this procedure to flush the system.

**NOTE:** Use fluids and solvents that are chemically compatible with the equipment wetted parts. See the **Technical Specifications** sections of all the equipment manuals. Always read the material manufacturer's literature before using fluid or solvent in this Pump.

3. Select a drum containing a compatible material that can dissolve, clean, and eliminate the factory test oil

from the system. If necessary, check with the material supplier for a recommended flush material.

4. Before flushing, be sure the entire system and flushing drums are properly grounded. Refer to **Grounding the System** on page 24.
5. Perform steps 9 through 15 of the **Initial System Startup Procedure** on page 29 to load the drum containing the solvent.
6. Run the flush material through the system for approximately 1 to 2 minutes.
7. Remove the drum containing the flush material.

## Adjusting the Drum Lid Holder Before Initial Use

1. Adjust the lower Drum Lid Holder (J) channel as low as it will go on the side of the ram post. The channel should be 1 in. (25 mm) higher from the floor in the front compared to the back.

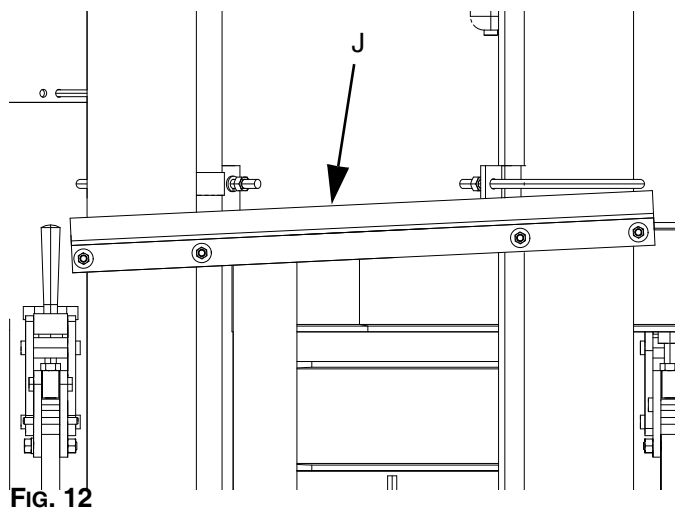
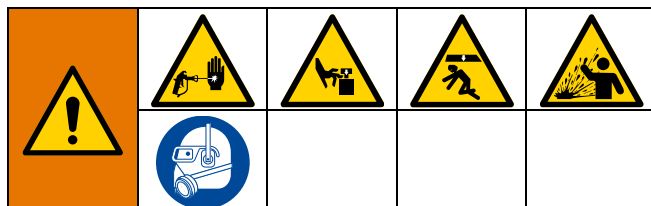

FIG. 12

2. Loosen the upper Drum Lid Holder (J) channel. Place the lid in the center of the lower channel. Lower the upper channel until it contacts the lid. Tilt the rear of the upper channel down 1/2 to 1 in. (13 to 25 mm) and tighten all bolts.
3. The lid should roll in and out from the front and not roll out the rear.

## Initial System Startup Procedure



To reduce the risk of serious bodily injury, such as skin injection or splashing fluid in the eyes or on the skin, always wear eye protection and protective clothing when installing, operating, or servicing this equipment.

Moving equipment parts can cause personal injury, including severing of hands or fingers. Keep hands and fingers away from the Follower Plate, Pump inlets, and the drum when raising or lowering the Follower Plate to reduce the risk of pinching or amputating hands or fingers.

### NOTICE

The use of a non-compatible lubricant can cause material contamination or inadequate performance. Use only a lubricant compatible with the material to be pumped. Check with the material supplier for a recommended lubricant.

To help avoid damage to equipment, do not use a drum of material that has been dented or otherwise damaged; damage to the Follower Plate wiper may result.



To reduce risk of injury or equipment damage:

- Make sure all material hose connections are secure.
- Do not pressurize the system until you have verified the system is ready and it is safe to do so.

### Settings for Initial System Startup

The initial system startup procedure contains the checklist of settings, adjustments, and procedural steps that must be completed before the system is ready for daily operation.

**NOTE:** Complete the startup procedure for the LH Supply Unit (A) first. Then, repeat the startup procedure for the RH Supply Unit (B).

Perform the initial system startup procedure as follows:

1. Check all material hoses and fittings to ensure tightness and to prevent any material leakage.
2. Check all system air lines. Make sure that all routing of air lines will not interfere with any moving components within the system.
3. Fill the packing nut/wet cup on both Pumps 1/3 full with Graco throat seal liquid (p/n 206995). Refer to instruction manual 308147 or 308148 for details.
4. Open the Main Air Shutoff Valve (P), making air pressure available to the unit. See FIG. 10 on page 25.
5. At the Pneumatic Logic Panel (G), open the Panel Air Inlet Valve (AH), making air pressure available to the Pneumatic Logic Panel. See FIG. 4 on page 13.
6. Adjust both Pump main air regulators (AC, AE) to 0 psi.
7. FOLLOWER VENT Directional Valve (AD) switch should be in AUTO position.
8. Set the RAM POSITION Switch (AG) to RAISE.
9. Press the RAM UP Pushbutton (AF) to raise the Follower Plate (D) above the height of the material drum to be used.
10. Set the RAM POSITION Switch (AG) to HOLD/NEUTRAL.

### Adjusting the Pump Regulators

**NOTE:** Both Pumps must operate at the same cycles per minute rate to prevent the occurrence of uneven drum evacuation.



**NOTE:** For the maximum air input pressure for each Pump, see the appropriate manual shown in **Related Manuals** on page 3.

11. Run the system under normal conditions. Adjust the PUMP NO. 1 REGULATOR Control Knob (AC) to the desired setting as follows:

- a. Turn the knob clockwise to increase air pressure or counterclockwise to decrease air pressure. See FIG. 5 on page 14.
  - b. Check the air gauge to verify the air pressure setting.
12. Repeat step 29 to adjust the air regulator for the PUMP NO. 2 REGULATOR Control Knob (AE).

### Adjusting the RAM UP and RAM DOWN Air Regulators

13. At the Pneumatic Logic Panel (G) (see FIG. 4 on page 13), open the hinged cover.
14. Set the RAM POSITION Switch (AG) to RAISE and push the RAM UP Pushbutton (AF). Verify that the Follower Plate (D) raises at the desired speed. If not, perform the following steps:
- a. Adjust the RAM UP Air Regulator (AJ). Turn the knob clockwise to increase the amount of air pressure. Check the air gauge to verify that air pressure was increased. See FIG. 5. The air pressure factory setting is 50 psi, and it is not recommended to exceed 80 psi.
  - b. Verify that the R3 Regulator (AL) is set to 5 to 10 psi (0.035 to 0.07 MPa, 0.35 to 0.7 bar).

			
<p>Do not set the R3 Regulator higher than 5 to 10 psi (0.035 to 0.07 MPa, 0.35 to 0.7 bar). Setting the R3 Regulator pressure higher than recommended can cause the Follower Plate (D) to drop and result in operator injury.</p>			

<b>NOTICE</b>
<p>Failure to adjust the Regulator R3 properly can cause the platen to exit the drum at a high rate of speed, risking damage to the equipment.</p>

- c. Repeat step 32.a until the ram raises at the desired speed.
15. Set the RAM POSITION Switch (AG) to DOWN while observing the air gauge inside the panel.

16. Adjust the RAM DOWN Air Regulator (AK) to 50 psi (0.34 MPa, 3.4 bar) as follows (see FIG. 5):
- a. Turn the knob clockwise to increase air pressure or counterclockwise to decrease air pressure.
  - b. Check the air gauge to verify the air pressure setting. The air pressure factory setting is 50 psi, and it is not recommended to exceed 80 psi.
17. Close and secure the hinged cover.

### Preventing Pump Cavitation

**NOTE:** Cavitation occurs when the Pump cylinder did not fully load with material on the upstroke, and a cavity forms in the material after the Pump changes to the downstroke. Perform step 36 when there is Pump cavitation. If cavitation is not occurring, omit step 36 and proceed to step 37.

18. To prevent cavitation from occurring, perform the following steps:
- a. Press the PRIME PUMP Pushbutton to prime the Pumps and fill the material passages.
  - b. Verify that the PUMP READY Light turns on.
  - c. Lower the air motor air pressure until cavitation stops.
  - d. Increase the ram down pressure.

### Adjusting the Empty/Low Limit Switches

**NOTE:** When the low limit switch is activated, the Pumps are normally turned off automatically by a customer-supplied control, and a second set of Pumps begin pumping.

19. Adjust the low limit switch as follows:
- a. At the Junction Box Panel (H) (FIG. 6), set the RAM POSITION Switch (AG) to LOWER, allowing the Follower Plate to activate the low limit switch.

- b. Verify that the Follower Plate (D) lowers to the limit set point: a level between 1 -4 in. (25.4 -101.6 mm) from the bottom of the drum.
- c. Adjust the low limit switch to activate at the level defined in step 37.b. See FIG. 13.

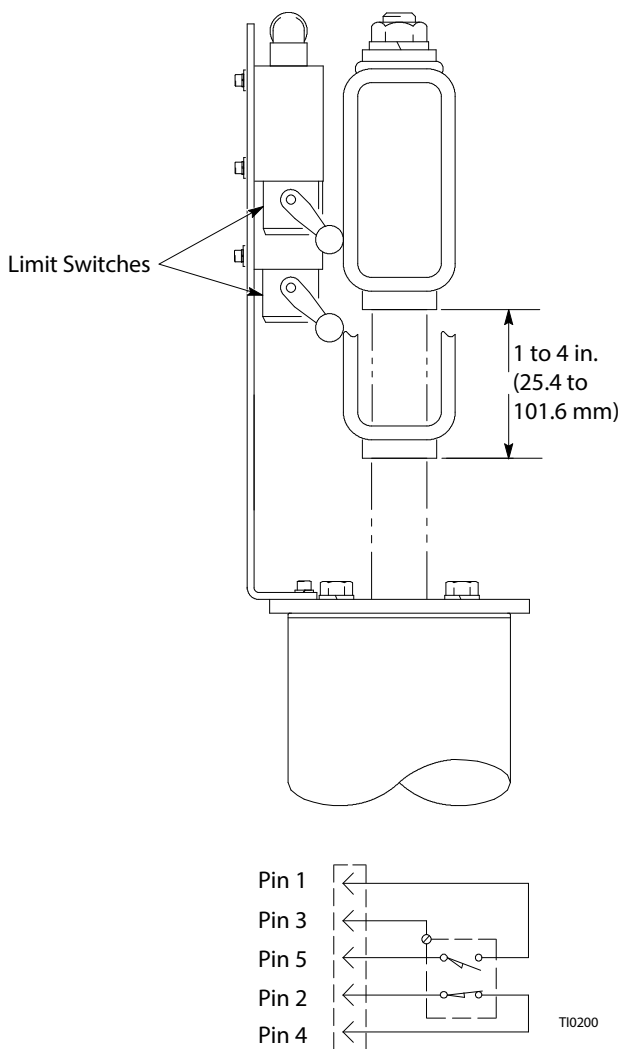

FIG. 13

## Changing Empty Drums

**NOTE:** After the automatic Pump crossover has taken place, immediately replace the empty drum with a new, full drum. If both Uni-Drums become empty at the same time:

- Material will stop being delivered to the dispenser.
- Air may enter the supply hose or pipe header.

- Pump runaway could occur, resulting in damage to the Pumps.

## Drum Changing Procedure

To remove an empty drum and load a new, full drum:

1. If used, verify that the two front and rear Drum Clamps (K) are engaged on the Uni-Drum ram base.
2. Check that the Pump air is turned off. On the Junction Box Panel (H), the PUMP ACTIVE and PUMP READY lights are not lit.
3. Check that the RAM UP Air Regulator (AJ) is set to 50 psi. It is not recommended to exceed 80 psi.
4. Close the two ball valves at the outlet manifold at the rear of the Uni-Drums.
5. To raise the Follower Plate (D):
  - a. Set the RAM POSITION Switch (AG) to RAISE, then wait 5 seconds.

**NOTE:** If RAM UP Pushbutton (AF) is pushed within 5 seconds, the vent valves may open before the pressure under the Follower Plate (D) is relieved causing the material to bleed past the vents.

- b. Push and hold the RAM UP Pushbutton (AF) as the Follower Plate (D) slowly rises.
6. With the ram raised and the RAM POSITION Switch (AG) set to RAISE, pull the Drum Clamps (K) (if used) back and remove the empty drum, using a suitable lifting device.



Use a long-handled flat-bladed ice scraper if it is necessary to scrape the bottom of the Follower Plate (D). To avoid serious injury, do not put your hands between the plate and the drum.

7. Being careful not to damage the Follower Plate (D) wipers, wipe or scrape any material buildup from the Follower Plate (D) and wipers, and properly dispose of the waste material.

## Load Material

### NOTICE

When opening a new drum, take care to remove the cover by holding it level. Tipping the cover may allow accumulated dirt to spill into the material, which can damage the equipment. Also check that the drum is not damaged or dented.

8. Remove the cover from the new drum and remove any other packing from the drum, exposing the material. Make sure there are no foreign objects on the surface of the material.
9. Position the new drum, using a suitable lifting device, under the raised Follower Plate (D). Check that the RAM READY Light is lit.
10. It is extremely important to lubricate the Follower Plate wiper with a lubricant that is compatible with the material to be pumped. Check with your material supplier for compatibility.
11. If used, push the two front and rear Drum Clamps (K) forward until engaged.



To reduce the risk of serious bodily injury, such as splashing fluid in the eyes or on the skin, always wear eye protection and protective clothing when operating this equipment.

The pressure relieved by removing the bleed sticks may cause the Follower Plate (D) to lower unexpectedly. To prevent personal injury from moving parts, such as pinching or amputating hands or fingers, keep hands and fingers away from the Follower Plate (D) when removing the bleed sticks.

12. Remove the bleed sticks from the Follower Plate (D).



Before lowering the Follower Plate (D) into the drum, make sure that nothing is between the Follower Plate and the drum, or between the ram tie bar and the top.

13. Lower the Follower Plate (D) as follows:

- a. Set the RAM POSITION Switch (AG) to LOWER.
  - b. Lower the Follower Plate (D) until the material is evident in the Bleed Ports (Q).
  - c. Set the RAM POSITION Switch (AG) to HOLD/NEUTRAL
  - d. Replace the bleedsticks.
  - e. Set the RAM POSITION Switch (AG) to LOWER.
14. Close both Pump No. 1 and Pump No. 2 inlet valves (located on top of the air motor).
  15. To prime the Pump, press the PRIME PUMP Pushbutton.
  16. Set the Pump air pressure to 30 psi.
  17. Check that the AIR PRESS. ON indicator is lit.
  18. Use a catch device to bleed the Pump. Slowly open Pump No. 1 bleed valve. Back off the adjustment screw several turns; do not remove the screw.
  19. Slowly open the bleed-type air valve to the air motor. Allow the Pump to cycle slowly until all air escapes and material flows free of air from the bleed valve.

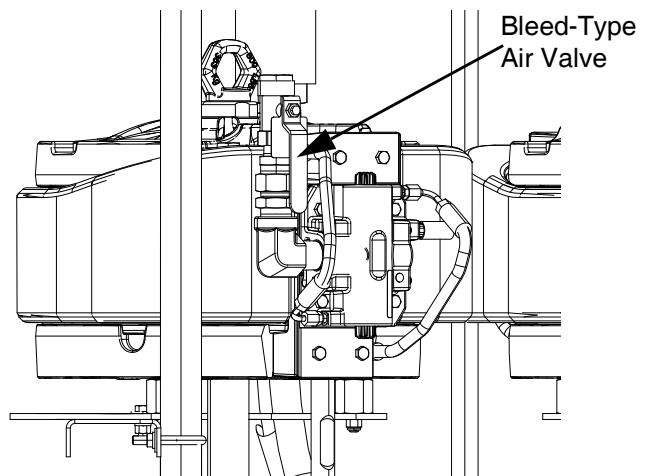

FIG. 14

20. Close the bleed-type air valve and Pump bleed valve.



21. Wipe any excess material from the Pump bleed valve outlet to prevent material from drying and curing. Cover the Pump bleed valve outlet with a material-compatible grease.

**NOTE:** If the Pump bleed valve has a grease zerk, apply a material-compatible grease into the zerk fitting until grease flows from the grease bleed hole.

22. Repeat these steps for Pump No. 2.

**NOTE:** If the Pump does not prime properly, which may occur with heavier, high viscosity fluids, increase the air pressure with the RAM DOWN Air Regulator (AK).

**NOTE:** If fluid is forced out around the top wiper, ram pressure is too high; decrease the air pressure with the RAM UP Air Regulator (AJ).

**NOTE:** Ram pressure adjustments are carried out using the dual REGULATOR Control Knobs (AC, AE) inside the Pneumatic Logic Panel (G). The upper regulator knob controls the downward pressure of the ram, and the lower regulator knob controls the upward pressure of the ram. See FIG. 5 on page 14.

23. After closing the bleed valve, return PUMP NO. 1 and PUMP NO. 2 REGULATOR Control Knobs (AC, AE) to the normal Pump pressure setting.

24. Open the air motor ball valves.

25. Open the ball valve in the outlet manifold from Pump No. 1 and 2.

26. Remove the waste containers, clean up any spilled material, and dispose of the waste material properly.

27. Press the PUMP RESET Pushbutton to restore the system to operation.

28. Check that the following lights are lit:

- SYSTEM PRESSURIZED
- AIR PRESS ON
- RAM READY
- PUMP READY

## Daily System Startup

This procedure is normally provided by the integrator.

## System Shutdown

This procedure is normally provided by the integrator.

## Stopping the System

To stop the system, close the Main Air Shutoff Valve (P) (see FIG. 15) to the Supply Unit.

## Restarting the System

To restart the system, perform the following steps:

1. Open the Main Air Shutoff Valve (P) to the Supply Unit (see FIG. 15).
2. At the Junction Box Panel (H), press the PUMP RESET Pushbutton, which restarts the Pumps after the Pumps were turned off. See FIG. 6 on page 16.

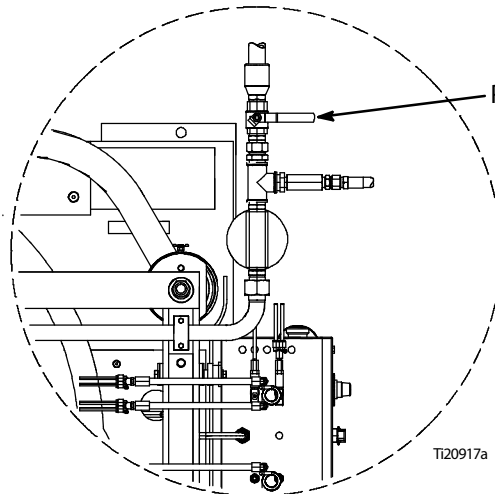

FIG. 15

# Pressure Relief Procedures

These procedures describe how to relieve pressure from the system.



Follow the Pressure Relief Procedure whenever you see this symbol.

<p>This equipment stays pressurized until pressure is manually relieved. To help prevent serious injury from pressurized fluid, such as skin injection, splashing fluid and moving parts, follow the Pressure Relief Procedure when you stop spraying and before cleaning, checking, or servicing the equipment.</p>				

## Fluid Pressure Relief Procedure

This procedure describes how to relieve pressure on the Follower Plate (D) and in the Pumps (C). Use this procedure whenever you shutoff the Pumps and before checking or adjusting any part of the system.

At the Pneumatic Logic Panel (G), perform the following steps:

1. Close the Main Air Shutoff Valve (P). See FIG. 16.
2. Open any downstream fluid valves, such as the ball seat applicators on the ram assemblies, that may be part of the system.
3. Press the BULK SUPPLY DEPRESSURIZATION Pushbutton on the Junction Box Panel (H).
4. After the pressure is relieved from the Follower Plate (D), raise the Follower Plate by setting the RAM POSITION Switch (AG) to the RAISE position.

**NOTE:** In order to fully relieve system pressure, including ram cylinders, the steps in the **Pneumatic Pressure Relief Procedure** on page 35 must be performed.

## Pneumatic Pressure Relief Procedure

This procedure describes how to relieve pressure on the Pneumatic Logic Panel (G) and cylinders. Use this procedure whenever you perform ram assembly service on the piston rod seal or the ram piston.

1. Follow **Fluid Pressure Relief Procedure** on page 34.
2. Fully lower the ram by setting the RAM POSITION Switch (AG) to LOWER. Leave the switch in the LOWER position.
3. Open the door on the Pneumatic Logic Panel (G).
4. Adjust the air pressure to 0 PSI for the RAM DOWN Air Regulator (AK). Refer to the gauge on the RAM DOWN Air Regulator (AK) and R3 Regulator (AL) to verify the ram has been depressurized. See FIG. 17.
5. Slowly open the drain cock located on the bottom of the air cylinders (CL).
6. After the air pressure has been relieved, remove the Ram Down air line running from the top of the Pneumatic Logic Panel (G) to the ram cross bar (CB).
7. Close the Main Air Shutoff Valve (P) on header.
8. Leave the drain cock open and the Ram Down airline removed until service is complete.
9. After service is complete, close drain cocks and make all pneumatic connections and open the Main Air Shutoff Valve (P) to header. Perform the **Adjusting the RAM UP and RAM DOWN Air Regulators** procedure, page 30.

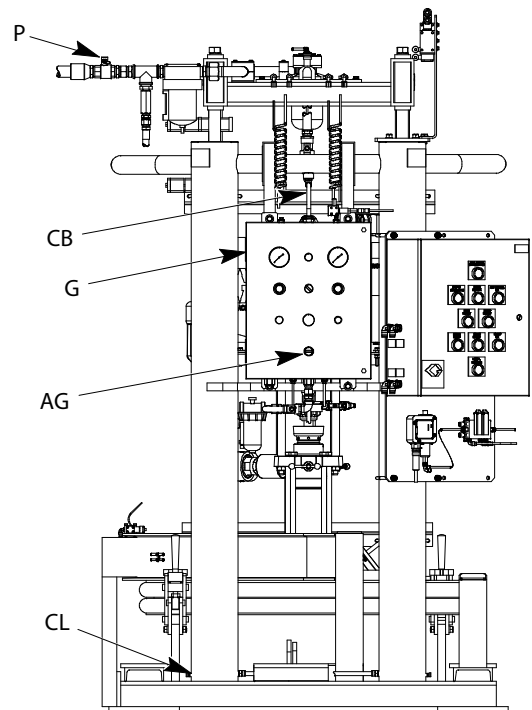

FIG. 16

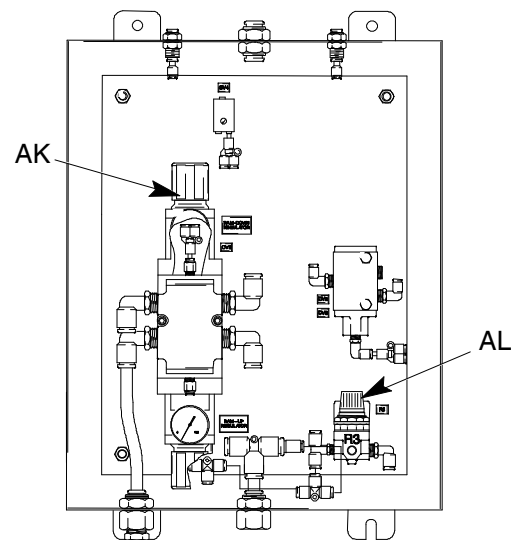

FIG. 17

# Maintenance

## Preventative Maintenance Schedule

The operating conditions of your particular system determine how often maintenance is required. Establish a preventive maintenance schedule by recording when and what kind of maintenance is needed, and then determine a regular schedule for checking your system.

## Flushing the System

Flush the Pump:

- Before the first use
- When changing material or fluid part number or brand
- Before fluid can dry or settle out in a dormant Pump (check the shelf life or pot life of catalyzed fluids)
- Before storing the Pump.

Flush with a fluid that is compatible with the fluid you are pumping and with the wetted parts in your system. Check with your fluid manufacturer or supplier for recommended flushing fluids and flushing frequency.

				
<p>To avoid fire and explosion, always ground equipment and waste container. To avoid static sparking and injury from splashing, always flush at the lowest possible pressure.</p>				

To flush the system, perform the following procedure:

1. Place a drum of compatible flush material under the Follower Plate (D).
2. Run the Pumps to move the flush material through the system for approximately 1 to 2 minutes or until the solution is clean.
3. Remove the drum containing the flush material from under the Follower Plate (D).
4. Return the system to previous operation settings.

## Cleaning the System

NOTICE
<p>Cleaning the system after using it can prevent material contamination, which may cause the material to fail or perform poorly. Do not load new material into a contaminated system.</p> <p>Clean the system to avoid untimely equipment malfunctions and to ensure that system components operate efficiently</p>

To clean the system, perform the following procedure:

1. Turn the RAM POSITION Switch (AG) to RAISE, then press the RAM UP Pushbutton to move the ram to the fully raised position.
2. To lock the ram in the fully raised position, move the RAM POSITION Switch to the HOLD/NEUTRAL position and insert both safety hitch pins (806) into the outer support bars (802) and install both pin lock clips.

**NOTE:** Locks that use 1/4 in. shackles can be used in place of the cotter pins (CP) provided with the safety hitch pins (806).

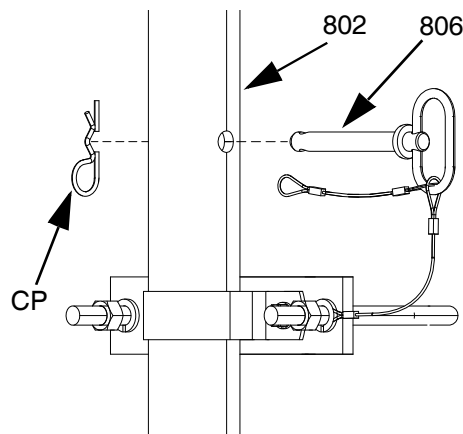





FIG. 18

3. Once both safety hitch pins (806) are secured, turn off all air to the system by closing the Main Air Shutoff Valve on the header (P) and follow your facility's pre-established lock-out/tag-out procedures. See FIG. 16 on page 35.

4. It is recommended to clean the platen between each drum change, or as recommended by your facility's maintenance plan.

				
<p>Use a long-handled flat-bladed ice scraper if it is necessary to scrape the bottom of the Follower Plate (D). To avoid serious injury, do not put your hands between the plate and the drum.</p>				

5. Being careful not to damage the Follower Plate (D) wipers, wipe or scrape any material buildup from the Follower Plate (D) and wipers, and properly dispose of the waste material.
6. Apply a generous amount of lubricant to the Follower Plate (D) wipers.
7. To clean vent valve:
  - a. Set the FOLLOWER VENT Directional Valve (AD) to the ON position. This opens the valve to allow you to clean out dried material.
  - b. When the vent is clean, set the FOLLOWER VENT Directional Valve (AD) to the AUTO position.
8. To place the ram back into operation, verify the RAM POSITION Switch (AG) is still in the HOLD/NEUTRAL position, and open the Main Air Shutoff Valve on the header (P).
9. Turn the RAM POSITION Switch (AG) to RAISE, then press the RAM UP Pushbutton (AF) to move the ram to the fully raised position.
10. Remove both safety hitch pins (806).
11. Return the system to previous operation settings.



## Wiper Lubrication

It is extremely important that the Follower Plate (D) wipers be thoroughly lubricated between drum changes. The Follower Plate (D) may stick without lubrication.

# Junction Box Panel Service

**NOTE:** Refer to **Junction Box Panel** on page 91 while servicing the Junction Box Panel (H).

## Indicator Light and Pushbutton Switch Removal



				
<p>All electrical wiring must be done by a qualified electrician and comply with all local codes and regulations.</p> <p>Installing and servicing this equipment requires access to parts which could cause an electric shock or other serious injury. Have only qualified electricians access the control assembly.</p>				

1. Shut off power to the Junction Box Panel (H).
2. Remove the cover from the Junction Box Panel (H).
3. Disconnect the lead wires from the terminals on the switch. For wiring information, refer to the **Electrical Diagram** on page 91. If necessary, label the wires to facilitate reconnection after replacing the component.
4. Loosen two screws which clamp the fixture to the cover. Rotate and remove the outer ring on the defective component counterclockwise to remove the light lens or switch. Separate the parts and remove them from the cover.

## Indicator Light and Pushbutton Switch Replacement

1. Reverse steps 2 through 4 in the previous paragraph.
2. For wiring information, refer to the **Electrical Diagram** on page 91.
3. Reapply power to the Junction Box Panel (H).
4. Verify that the replaced component operates correctly.
5. Return the system to previous operation settings.

## Light Bulb Removal

				
<p>All electrical wiring must be done by a qualified electrician and comply with all local codes and regulations.</p> <p>Installing and servicing this equipment requires access to parts which could cause an electric shock or other serious injury. Have only qualified electricians access the control assembly.</p>				

1. Shut off power to the Junction Box Panel (H).
2. Unscrew and remove the indicator light lens.
3. Gently press and rotate the bulb counterclockwise, 1/4 of a turn, unlocking the bulb from its socket. Remove the bulb from the socket.

## Light Bulb Replacement

Replace the light bulb as follows:

1. Insert the light bulb in the socket.
2. Gently press and rotate the bulb clockwise, 1/4 of a turn to lock the bulb in its socket.
3. Replace the lens.
4. Reapply power to the Junction Box Panel (H).
5. Verify that the light bulb operates correctly.
6. Return the system to previous operation settings.

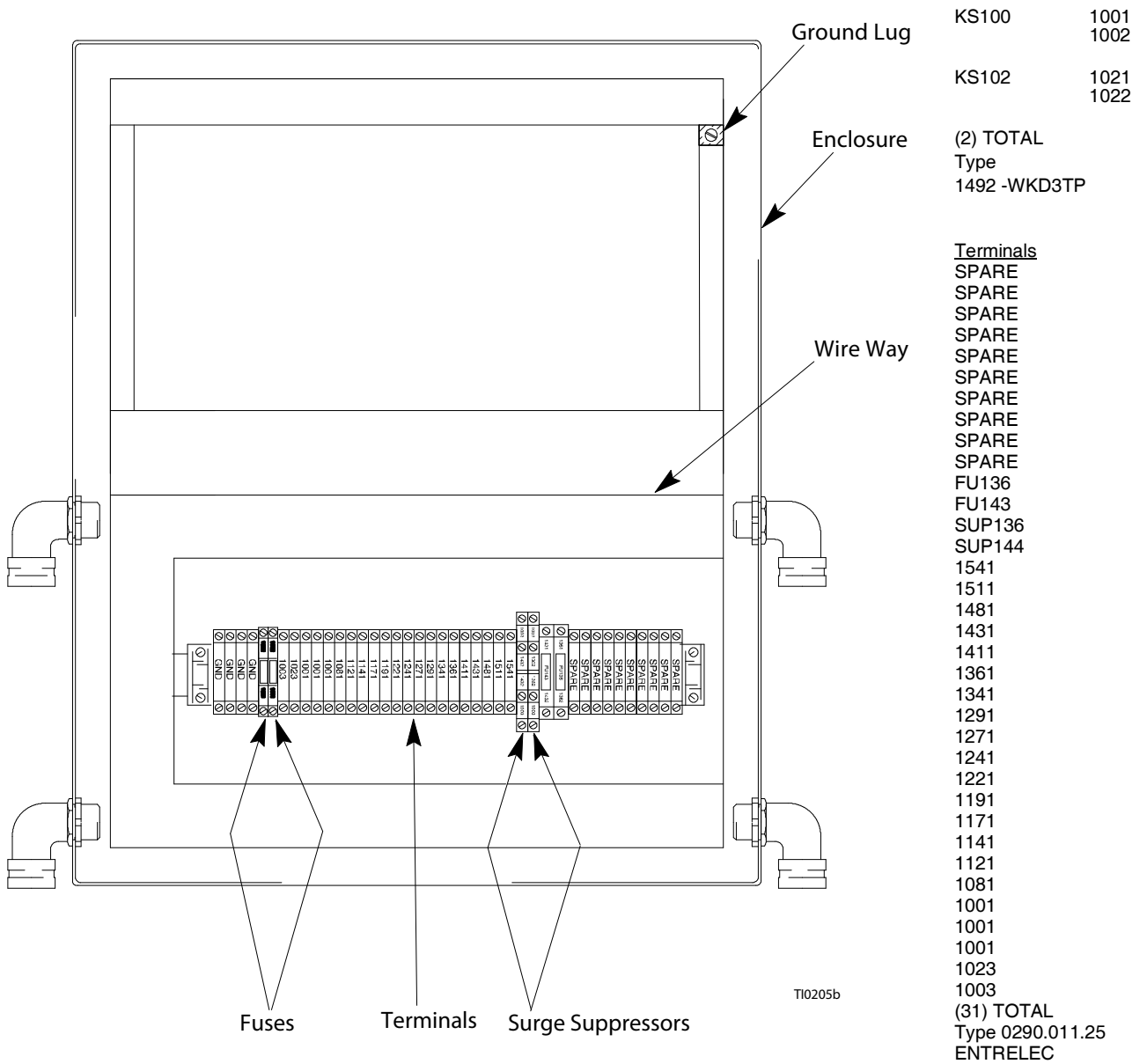



FIG. 19

## Fuse Removal

				
<p>All electrical wiring must be done by a qualified electrician and comply with all local codes and regulations.</p> <p>Installing and servicing this equipment requires access to parts which could cause an electric shock or other serious injury. Have only qualified electricians access the control assembly.</p>				

Remove the fuse as follows:

1. Shut off power to the Junction Box Panel (H).
2. At the Junction Box Panel (H), remove the cover from the Junction Box Panel.
3. Locate the failed fuse on the terminal strip. Reference FIG. 19 for the fuse terminal identification.
4. Carefully remove the fuse from the fuse holder.



## Fuse Replacement

Replace the fuse as follows:

**NOTE:** Check the new fuse to ensure that it matches the amp rating of the failed fuse.

1. Press both ends of the new fuse evenly into place in the fuse holder. See FIG. 19.
2. Reinstall the cover on the Junction Box Panel (H).
3. Reapply power to the Junction Box Panel (H).
4. Verify that the fuse operates correctly.
5. Return the system to previous operation settings.

## Surge Suppressor Removal

				
<p>All electrical wiring must be done by a qualified electrician and comply with all local codes and regulations.</p> <p>Installing and servicing this equipment requires access to parts which could cause an electric shock or other serious injury. Have only qualified electricians access the control assembly.</p>				

1. Shut off power to the Junction Box Panel (H).
2. At the Junction Box Panel (H), remove the cover off the Junction Box Panel.
3. Locate the failed surge suppressor on the terminal strip. Reference FIG. 19 for the surge suppressor terminal identification.
4. Remove the two screws and surge suppressor from the terminal strip.

## Surge Suppressor Replacement

Replace the surge suppressor as follows:

1. Install the new surge suppressor into place on the terminal strip using the two screws. See FIG. 19.
2. Reinstall the cover on the Junction Box Panel (H).
3. Reapply power to the Junction Box Panel (H).
4. Verify that the fuse operates correctly.
5. Return the system to previous operation settings.



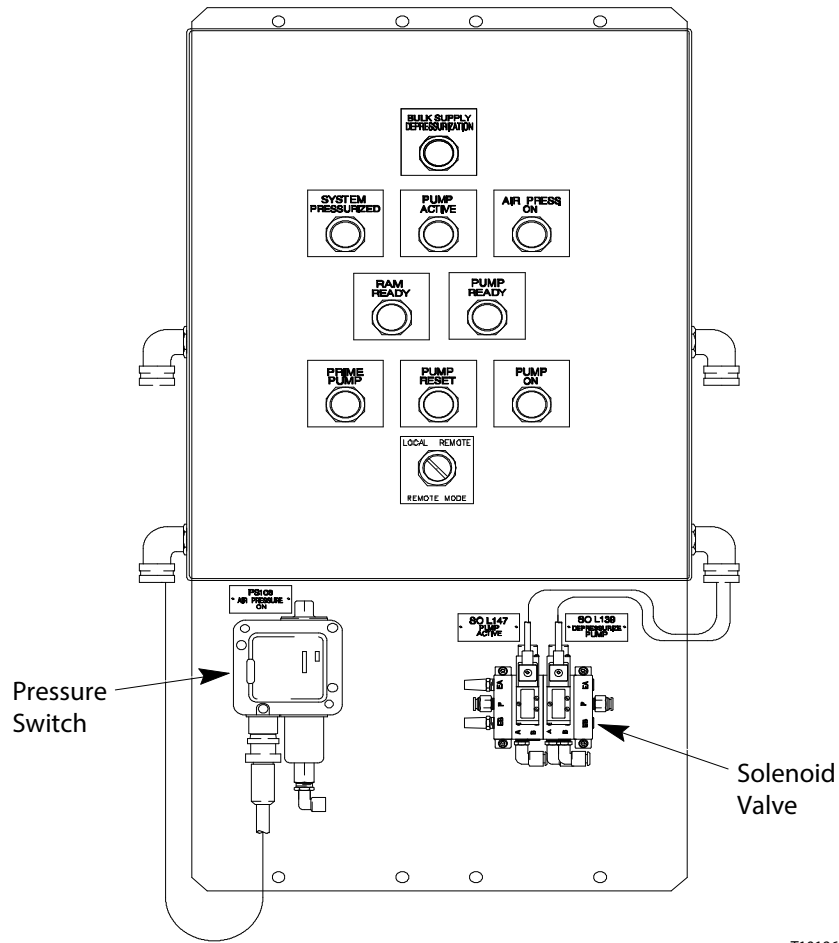



FIG. 20

T10196

# PLC Interface Accessory Kit Service

## Valve Assembly Bank

				
<p>All electrical wiring must be done by a qualified electrician and comply with all local codes and regulations.</p> <p>Installing and servicing this equipment requires access to parts which could cause an electric shock or other serious injury. Have only qualified electricians access the control assembly.</p>				

Remove the valve assembly bank that is mounted below the Junction Box Panel (H) as follows:

**NOTE:** The valve assembly bank has two solenoids (SOL139 and SOL147) that are used as switches to control Pump operation. SOL139 depressurizes the Pumps. If the output is high (open), Pumps will depressurize. SOL147 turns air on to the Pumps.

1. Shut off power to the Junction Box Panel (H).

### Valve Assembly Removal



2. Remove the cover off the Junction Box Panel (H).
3. Locate the valve assembly (203) that is attached to the mounting plate (201) below the Junction Box Panel (217). See FIG. 21.
4. Disconnect the two cables (216) from the terminal strip inside the Junction Box Panel (217) for the valve assembly (203) bank. For wiring information, refer to the **Electrical Diagram** on page 91.
5. Remove four cap screws (205), the lock washers (206), and the valve assembly (203) from the mounting plate (201).

### Valve Assembly Replacement

6. Install the new valve assembly (203) on the mounting plate (201) using the four cap screws (205) and lock washers (206). See FIG. 21.
7. Reconnect the two cables (216) on the terminal strip inside the Junction Box Panel (217) for the valve assembly (203) bank. For wiring information, refer to the **Electrical Diagram** on page 91.

8. Reinstall the cover on the Junction Box Panel (H).
9. Reapply power to the Junction Box Panel (H).
10. Perform the **Daily System Startup** procedure on page 33 at the applicable Supply Unit (LH or RH).
11. Verify that the valve assembly (203) bank operates correctly.
12. Return the system to previous operation settings.

## Pressure Switch Assembly Replacement

				
<p>All electrical wiring must be done by a qualified electrician and comply with all local codes and regulations.</p> <p>Installing and servicing this equipment requires access to parts which could cause an electric shock or other serious injury. Have only qualified electricians access the control assembly.</p>				

Remove the pressure switch assembly that is mounted below the Junction Box Panel (H) as follows:

**NOTE:** The pressure switch (PS108) turns air pressure on the system.

1. Shut off power to the Junction Box Panel (H).

### Switch Removal

2. Remove the cover from the Junction Box Panel (H).
3. Locate the pressure switch assembly (202) that is attached to the mounting plate (201) below the Junction Box Panel (217). See FIG. 19.
4. Disconnect the 5-pin cord (211) from the pressure switch assembly (202). For wiring information, refer to the **Electrical Diagram** on page 91.
5. Disconnect the end of the lead wire from the pressure switch assembly (202). Leave the other end of the lead wire connected to the valve assembly bank (203).

- Remove the two cap screws, the lock washers, and the pressure switch assembly (202) from the mounting plate (201).

### Switch Replacement

To replace the switch, follow the switch removal steps in reverse order.

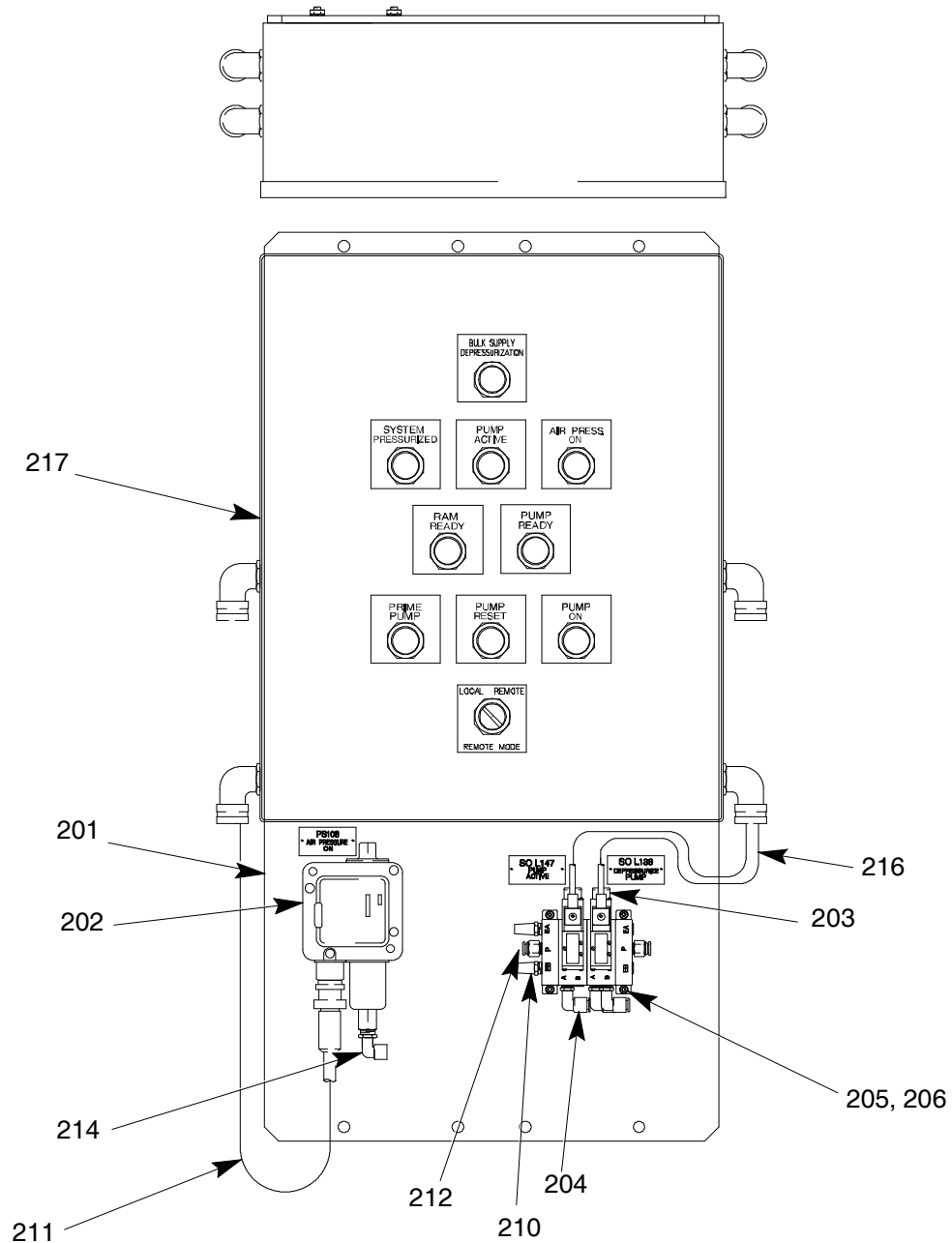

TI0208

FIG. 21

# Pneumatic Logic Panel Service

## Filter/Element Replacement

Listed below are the filters used with the ram assembly on the Uni-Drum Supply System.

- The Main Air Filter (N) between the air supply source and both air motors. See FIG. 22.
- The Pneumatic Panel Air Filter (F) between the air supply source and the Pneumatic Logic Panel (G). See FIG. 23.

To replace an air filter/element, perform the following steps:



1. Follow the **Pressure Relief Procedures** on page 34.
2. At the Junction Box Panel (H), verify that the **SYSTEM PRESSURIZED** and **RAM READY** lights turn off.

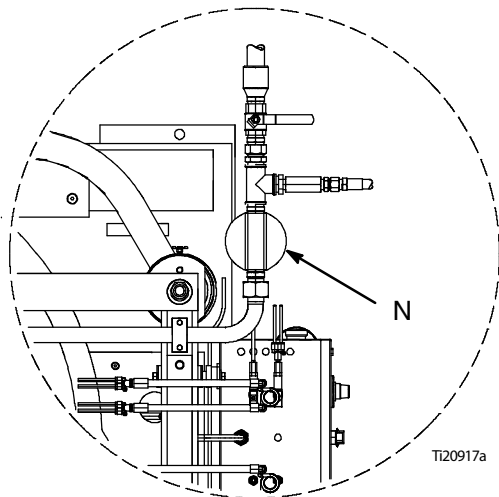

FIG. 22

## Filter Removal

3. Turn the air filter counterclockwise to unscrew the filter from its mounting.

## Filter/Element Replacement

4. Replace the old air filter element with a new filter element.
5. Clean the sight glass, if necessary. Reinstall the sight glass back on its threaded mounting. Tighten the sight glass.
6. Perform the **Daily System Startup** procedure on page 33.
7. Check for air leakage around the filter.
8. Return the system to previous operation settings.

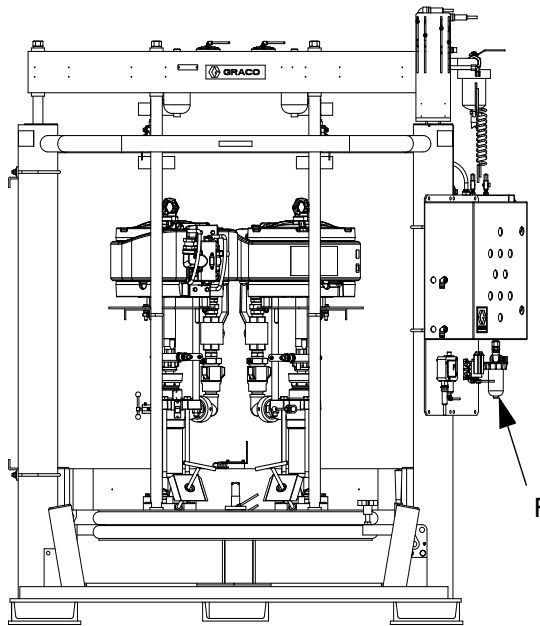

FIG. 23

# Ram Assembly Service

## Piston Rod Seal Service



1. Relieve the air pressure. Follow the **Pneumatic Pressure Relief Procedure** on page 35.
2. Remove the four nuts and lockwashers holding the tie bar to the rods. Remove the tie bar.
3. Remove the guide sleeve retaining ring by gripping the ring tab with a pair of pliers and rotating the ring out of its groove.
4. Remove the guide sleeve by sliding it off of the rod. Four 1/4 in. -20 holes are provided to ease removal of the guide sleeve.



Do not use pressurized air to remove the guide sleeve or piston. Failure to follow this instruction may result in personal injury.

5. Inspect the parts for wear or damage. Replace as necessary.
6. Install new O-rings and seal guard. Lubricate the packings with O-ring lubricant.
7. Slide the guide sleeve onto the rod and push it into the cylinder. Replace the retaining ring by feeding it around the guide sleeve groove.
8. Reinstall the tie bar using the nuts and lockwashers. Torque to 40 ft-lb (54 N•m).

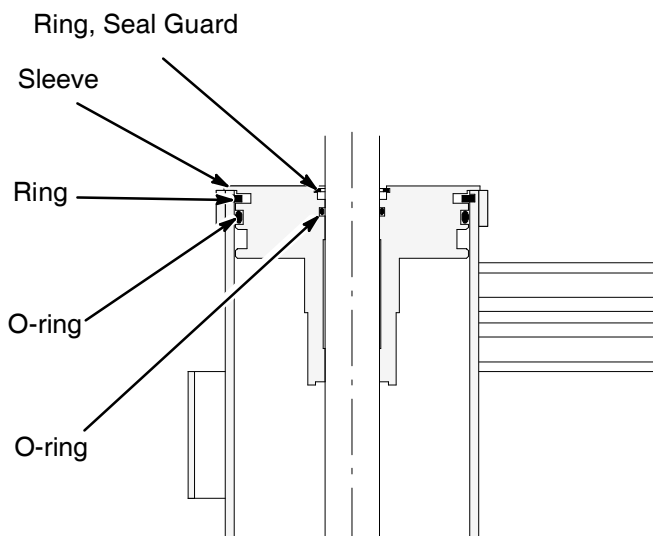

Refer to Repair Kit 918110.

7056A

**FIG. 24**

## Ram Piston Service



1. Relieve the air pressure. Follow the **Pneumatic Pressure Relief Procedure** on page 35.
2. Remove the tie bar as explained in the **Piston Rod Seal Service** section on page 45.
3. Remove the guide sleeve and slide it off of the piston rod.



Do not use pressurized air to remove the guide sleeve or piston. Failure to follow this instruction may result in personal injury.

4. Carefully pull the piston rod straight up out of the cylinder. If the rod is cocked to one side, the piston or inside surfaces of the cylinder could be damaged.
5. Carefully lay the piston and rod down so the rod will not be damaged or bent. Remove the lower piston retaining ring. Slide the piston off the piston rod.
6. Install new O-ring seals on the piston rod and the piston. Lubricate the piston and seals. Reinstall the piston and retaining ring.
7. Carefully insert the piston into the cylinder and push the rod straight down into the cylinder. Add 3 ounces of lubricant to each cylinder after inserting the piston.
8. Slide the guide sleeve onto the piston rod. Reinstall the retaining ring and tie bar, as explained under **Piston Rod Seal Service** section on page 45.

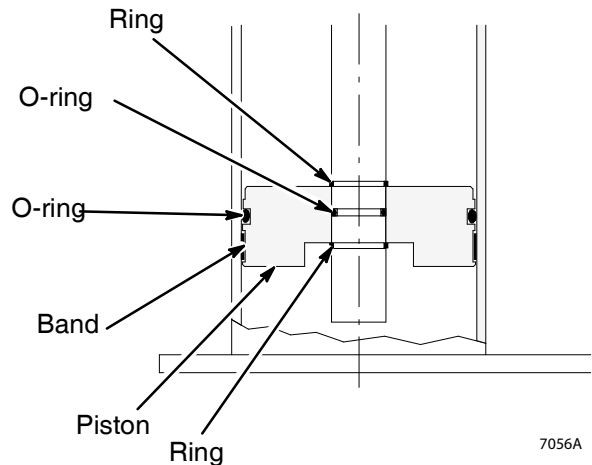







FIG. 25

## Low/Empty Limit Switch Replacement

				
<p>During operation, keep hands and fingers away from Limit Switches (S) to reduce the risk of pinching or amputating hands or fingers.</p>				

To replace the Low/Empty Limit Switch, perform the following steps:

1. Perform the System Shutdown procedure provided by the integrator at the applicable Supply Unit (LH or RH).

				
<p>All electrical wiring must be done by a qualified electrician and comply with all local codes and regulations.</p> <p>Installing and servicing this equipment requires access to parts which could cause an electric shock or other serious injury. Have only qualified electricians access the control assembly.</p>				

2. Shut off power to the Junction Box Panel (H).

**NOTE:** The first limit switch closes when the Follower Plate (D) reaches the preset low limit level in the drum. The second limit switch closes when the Follower Plate (D) reaches the preset empty level in the drum. Both limit switches provide inputs to the PLC interface.

### Switch Removal

3. Between the two limit switches (305), locate the faulty switch. See FIG. 26.
4. Disconnect the wiring (301) for the limit switch at its power source. For reference, use the wiring diagram shown in FIG. 26.
5. Mark the surface on the ram limit bracket using a felt-tipped pen to ensure that the new lower limit switch is installed in the same spot.
6. Measure the distance from the mounting bracket (306) to the outer diameter of the limit switch roller to ensure that the new roller is installed in the same position.
7. Remove three cap screws (302), the lock washers (303), the plain washers (304), and the limit switch (305) from the limit bracket (306). See FIG. 26.

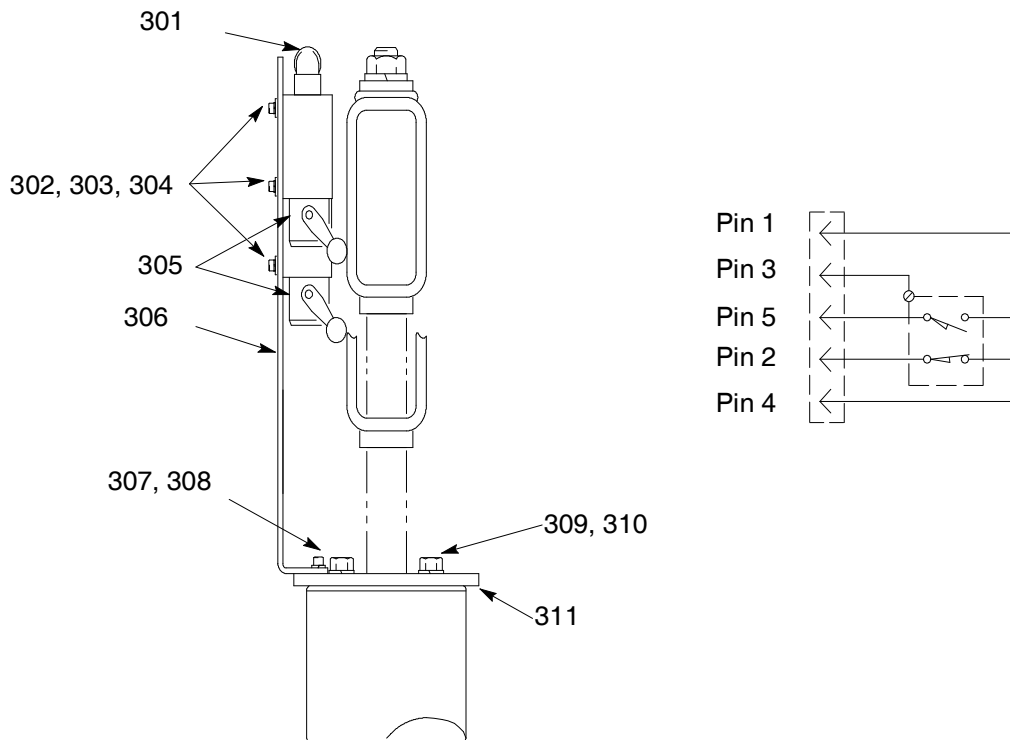

FIG. 26

T10200

## Switch Replacement

8. Install the new limit switch (305) on the limit bracket (306) using the three cap screws (302), lock washers (303), and plain washers (304). See FIG. 26.
9. Reconnect the wiring (301) for the limit switch at its power source. For reference, use the wiring diagram shown in FIG. 26.
10. Make sure that the limit switch roller is positioned in the same location per the measurement in step 6. See FIG. 26.
11. Reinstall the cover on the Junction Box Panel (H).
12. Reapply power to the Junction Box Panel (H).
13. Perform the **Daily System Startup** procedure provided by the integrator at the applicable Supply Unit (LH or RH).
14. Verify that the limit switch operates correctly.
15. Return the system to previous operation settings.

## Depressurization Valve (Ball Seat Applicator) Repair Procedure

Refer to instruction manual 3A1792 for the ball seat applicator (V1M350) service procedures and parts information.

## Servicing the Pumps

When the Pumps and air motors require service, refer to the applicable instruction manual, listed below, for detailed information.

Manual	Description	P/N
308147	Carbon Steel Dura-Flo™ Pump 1800 with XL 10000™ Air Motor	237555
308148	Stainless Steel Dura-Flo™ Pump 1800 with XL 10000™ Air Motor	241957
308213	XL 10000™ Air Motor	24X856

## Replacing Wipers



1. Perform the **Fluid Pressure Relief Procedure** on page 34.
2. To replace worn or damaged wipers (412), raise the Follower Plate (D) up out of the drum. Remove the drum from the base. Wipe the fluid off the Follower Plate (D).



Use a long-handled flat-bladed ice scraper if it is necessary to scrape the bottom of the Follower Plate (D). To avoid serious injury, do not put your hands between the plate and the drum.

3. Separate the wiper joint (WJ) and bend back the strapping (413a) covering the clamp setscrew (413c). See Detail A of FIG. 27. Loosen the setscrew, pull the end of the strapping through the clamp (413b) and remove the wiper.
4. Slide the strapping (413a) through the new wiper (412). Slide the clamp (413b) onto the new strapping and bend the strapping back approximately 3 in. (76 mm). Insert the strapping through the clamp a second time. See Detail B of FIG. 27.
5. Install the wipers on the Follower Plate (D). Position the wipers so that the wiper joints (WJ) are 180° apart.

**NOTE:** You will need the special banding tool (BT) shown in Detail C of FIG. 27 to tighten the strapping. Order Part No. 168092 Banding Tool.

6. Grip the strapping (413a) with the bonding tool (BT) as shown. With your thumb on the gripper lever (GL), turn the tool handle (TH) clockwise to apply tension.

**NOTE:** Be careful not to pull the cutting handle (CH) until you are ready to cut the strapping in step 8.

7. Continue turning the tool handle until you see the strapping stop moving through the clamp (413b). Stop turning the handle.



8. Tighten the setscrew with a wrench (W). Pull the cutting handle (CH) to cut. Remove the bonding tool (BT). Bend the strapping back over the clamp (413b).

9. Pound the wiper all the way around with a rubber mallet until the wiper joints (WJ) are butted tightly together.

10. Return the system to previous operation settings. Refer to the **Load Material** procedure on page 32.

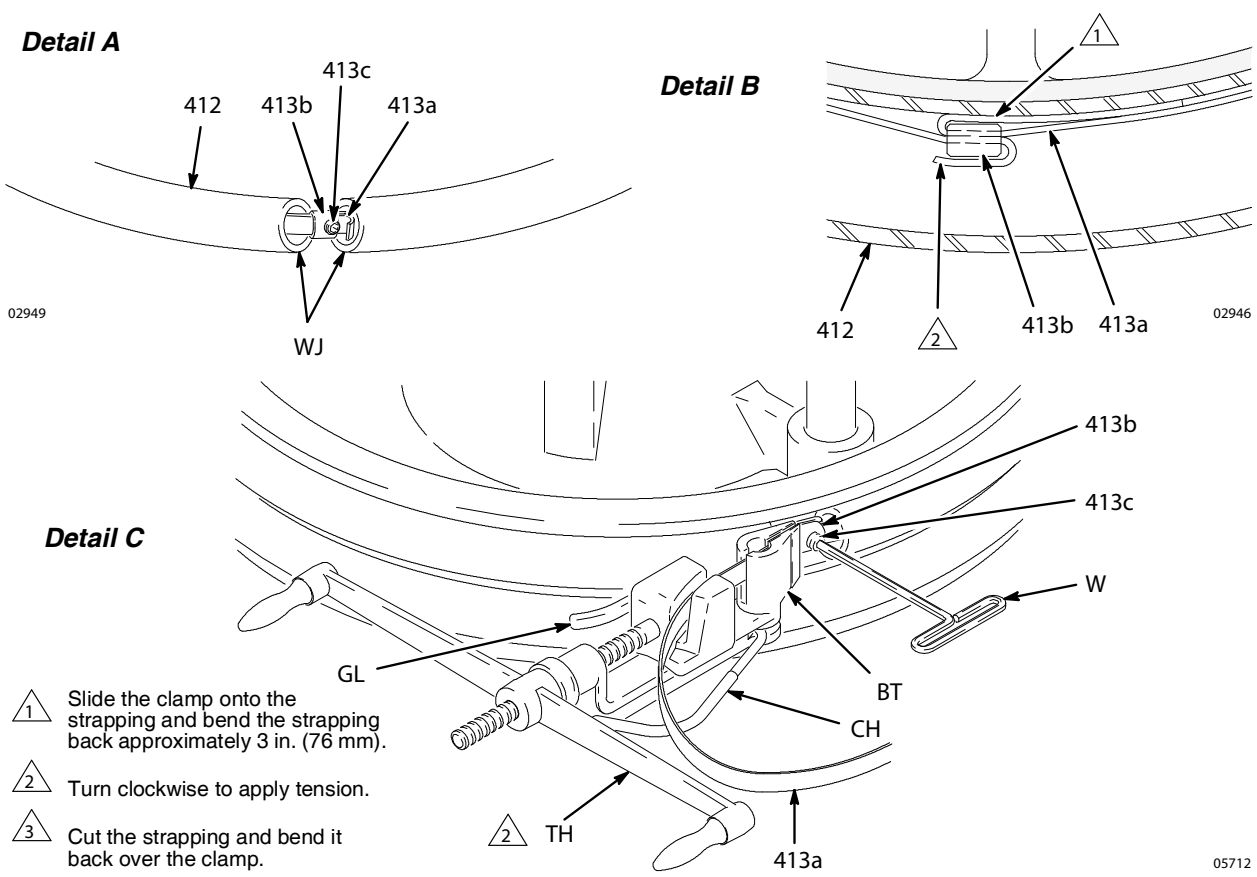

FIG. 27

## Pump Removal

**NOTE:** See **Parts** on page 56.



1. Relieve the air pressure from the air motors and ram assembly to be serviced. Follow the **Fluid Pressure Relief Procedure** on page 34.
2. Disconnect electrical power from the system.
3. Move the RAM POSITION Switch (AG) to HOLD/NEUTRAL.
4. Close the Pump outlet ball valves and relieve the fluid pressure from the Pumps at the Pump bleed valve on the ram assembly to be serviced.
5. Using an overhead lifting device, attach and secure a chain capable of lifting the weight of the Pump assembly to the eye at the top of the air motor.

**NOTE:** For effective Pump removal, the lifting point must be directly above the Pump and capable of moving sideways. The lifting action should be the “chain fall” type that allows a slow upward and downward movement.

**NOTE:** Check the **Technical Specifications** in the separate Pump manual to find the weight of the Pump being serviced. For example, Graco XL 10000™ 45:1 SST Pump (24Y208) weighs 236 lb (106 kg) per manual 308148.

6. Detach the air hose from the air motor.
7. Detach the fluid supply hose at the Pump outlet.

**NOTE:** When loosening the Pump and the air motor fasteners in steps below, ensure the chain slack is taken up to prevent the Pump assembly from falling.

8. On the Follower Plate adapter, loosen and rotate or remove four lugs and hex bolts holding the flange of the Pump lower.
9. On the underside of the air motor, remove the bolts securing the air motor to the motor support brackets. It may be necessary to move or remove some brackets for effective Pump removal.

10. Detach any other connections to the Pump assembly to ensure the Pump is free of attachments before removal. Possible connections include:
  - Air motor exhaust kit
  - Pump proximity switch kit
  - Pump grounding wire

**NOTE:** When lifting the Pump in steps below, ensure the lifting chain does not damage the air controls mounted at the top of the ram cross-members.

11. Using a “chain fall” style lifting device, slowly pull the Pump upward a few inches until the base of the Pump clears the Pump mounting adapter and the air motor clears the support brackets.
12. Pull the Pump assembly out of the ram assembly and guide the Pump assembly downward to the floor, placing the base of the Pump on a wood surface and taking care not to damage the seal area of the Pump inlet housing.
13. Remove the gasket and o-ring (32, 33) from the Pump adapter. They should be discarded and replaced when the Pump is reinstalled.
14. Clean excess and hardened material from the Pump adapter on the Follower Plate (D).
15. Ensure that material is not rising through the Pump adapter in the Follower Plate (D). If material is flowing upward, move the RAM POSITION Switch (AG) to RAISE until the flow stops, then move the switch back to HOLD/NEUTRAL.
16. Move the Pump assembly to a suitable work area and repair the Pump using the appropriate Graco Instruction Manual.

## Pump Installation

1. When the Pump is serviced and tested and ready to be replaced in the Uni-Drum ram assembly, perform the steps of the **Pump Removal** procedure in reverse order.
2. It is recommended that the Pump be tagged with the type and date of repair and the name of the technician who performed the repair.
3. Before returning the reassembled Pump to production use, it must be primed with material and air removed from the material. See the Starting and Adjusting the Pump section in your appropriate Pump Instruction manual shown in **Related Manuals** on page 3.

# Recycling and Disposal

## End of Product Life

At the end of the product's useful life, dismantle and recycle it in a responsible manner.

- Perform the **Pressure Relief Procedures**.
- Drain and dispose of fluids according to applicable regulations. Refer to the material manufacturer's Safety Data Sheet.
- Remove motors, batteries, circuit boards, LCDs (liquid crystal displays), and other electronic components. Recycle according to applicable regulations.
- Do not dispose of batteries or electronic components with household or commercial waste.



- Deliver remaining product to a recycling facility.

# Troubleshooting

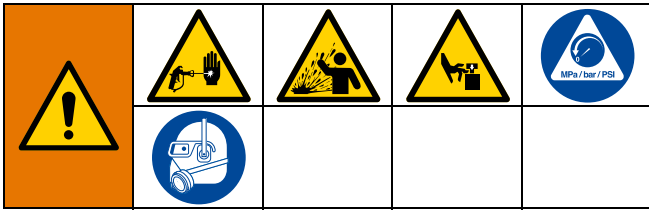

1. Follow **Pressure Relief Procedures**, page 34 and 35, before checking or repairing the Uni-Drum Supply System.

## Ram Assembly Troubleshooting

Problem	Cause	Solution
Ram won't raise or lower	Closed Main Air Shutoff Valve (P) or clogged air line	Open air valve, clear air line
	Not enough air pressure	Increase ram pressure
	Worn or damaged piston	Replace piston. See <b>Ram Piston Service</b> on page 46.
	Safety Pins (M) still in place	Remove pins.
Ram raises or lowers too fast	Ram air pressure too high	Decrease ram air pressure
Fluid squeezes past Follower Plate wipers	Ram air pressure too high	Decrease ram air pressure
	Worn or damaged wipers	Replace wipers. See <b>Replacing Wipers</b> on page 48.
Pump won't prime properly, or pumps air	Not enough ram air pressure	Increase ram pressure
	Worn or damaged ram piston	Replace ram piston. See <b>Ram Piston Service</b> on page 46.
	Bent drum has stopped Follower Plate	Replace drum

## Pump Troubleshooting

For additional information about the displacement Pump, refer to **Related Manuals** on page 3 to find the applicable instruction manual.

Problem	Cause	Solution
Rapid downstroke or upstroke (pump cavitation)	Air is trapped in Pump.	Bleed air from the Pump using this procedure: <ol style="list-style-type: none"> <li>1. Place a waste container under the Pump Bleed Port (Q).</li> <li>2. Press the PRIME PUMP Pushbutton to turn on air to the Pump.</li> <li>3. Allow material to flow from the Bleed Port until it is air-free.</li> <li>4. Release the PRIME PUMP Pushbutton to shut off air to the Pump. Close the Bleed Port.</li> <li>5. Turn air on to the Pump and set the Pump air regulator for normal operation.</li> </ol>
	Downstroke: Lower check in Pump is worn. Upstroke: Upper check in Pump is worn.	Rebuild and replace Pump, as necessary.
Material leaks around Pump outlet	Outlet fitting is loose.	Tighten outlet fitting.
Material leaks around Bleed Port (Q)	Bleed Port fitting is loose.	Tighten Bleed Port fitting.
Pump won't move up or down	Problem with air motor.	See <b>Air Motor Troubleshooting</b> chart on page 54.
	Foreign object lodged in Pump.	Remove object and rebuild Pump assembly.
Wet cup leaks	Worn throat packings.	Tighten wet cup. Replace throat packings.

## Air Motor Troubleshooting

For additional information about the air motor, refer to **Related Manuals** on page 3 to find the applicable instruction manual.

Problem	Cause	Solution
Air motor will not shift directions, stalled in DOWN position	Main air valve spool is dirty or damaged	Clean/rebuild main air valve.
Air motor will not shift directions, stalled in UP position		
Air motor stalled halfway between the top and bottom		
Air continually exhausting around air motor shaft.	Air motor shaft seal is damaged	Replace air motor shaft seal.
Air continually exhausting around the air valve/slide valve	Air valve/slide valve gasket is damaged	Replace the valve gasket.
Air continually exhausting from muffler while the motor is idle	Internal seal damage	Rebuild air motor.
Oil leaking from exhaust port	Too much lubricant mixed in with the air supply	Reduce lubricant supply.
Frost build-up on muffler	Air motor operating at high pressure, or high cycle rate	Reduce pressure, cycle rate, or duty cycle of the air motor.

## Junction Box Panel Troubleshooting

Problem	Cause	Solution
Power from PLC control panel is ON, but no indicator lights are lit at Junction Box Panel.	The knife switch disconnect contacts (KS100 and KS102) are open.	Check the PLC power connections at customer's site.
	One or more fuses blown.	Replace the blown fuse(s). Check FU136 and FU143 located inside the knife switch disconnect blocks.
	Voltage limit to circuits in Junction Box Panel was exceeded.	Check the surge suppressors SUP136 and SUP144. Replace if required. Reset power to unit.

## Pneumatic Logic Panel Troubleshooting

Problem	Cause	Solution
Ram will not move up or down.	Main air valve on box is not open. Air supply to unit is not on.	Open valve. Turn on air supply.
Ram will not move up.	Direction valve is not in the UP position. RAM UP Pushbutton (AF) is not pushed. Resistance in drum is too great. Insufficient lubrication of the Follower Plate seal.	Set direction valve to the UP position. Push RAM UP Pushbutton (AF). Turn air pressure up to 60 psi. The ram may take a few minutes to withdraw from the container. After the plate has been removed from the container, clean the seal and thoroughly lubricate.
Pumps will not operate.	Air regulator is set too low.	Increase air pressure setting.
Vent valve will not open.	FOLLOWER VENT switch is not in AUTO position.	Put FOLLOWER VENT switch in AUTO position.

# Parts

248306, 249339, 253676, 258910 - 47:1 Left Hand Supply Unit

248307, 249340, 253677, 258911 - 47:1 Right Hand Supply Unit

249152, 249341, 234972, 258956 - 35:1 Left Hand Supply Unit

249153, 249342, 234973, 258957 - 35:1 Right Hand Supply Unit

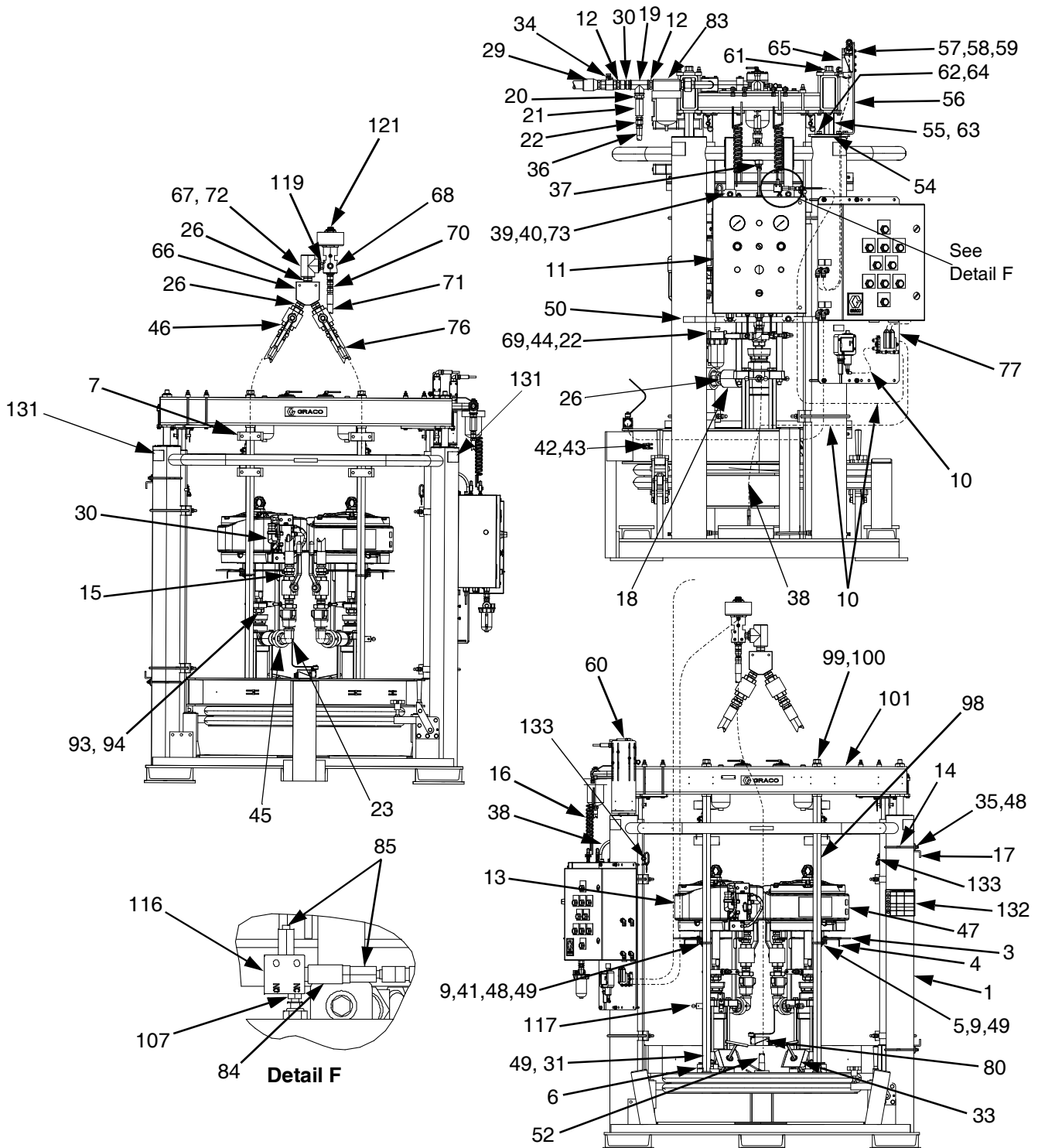



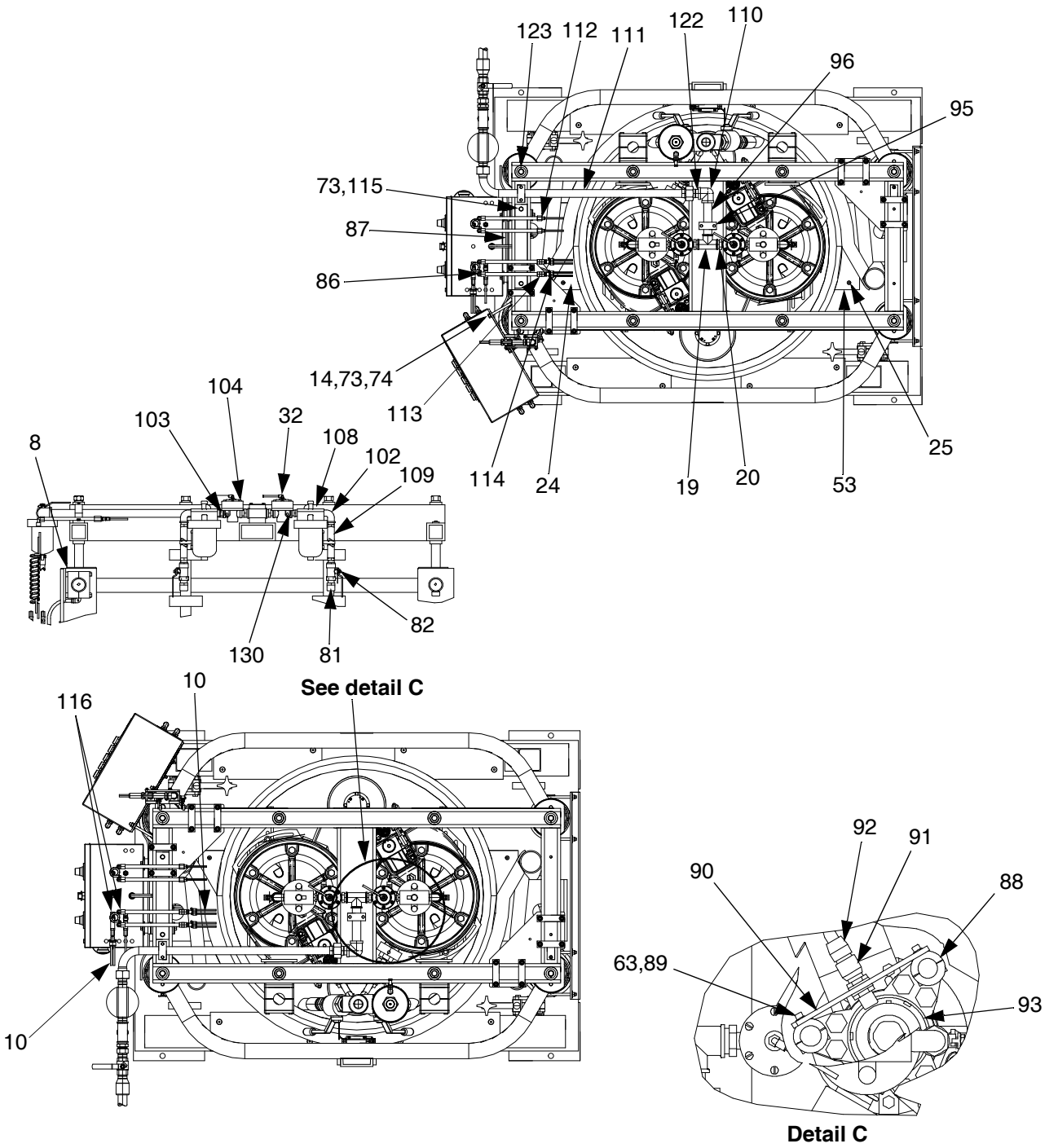

## Parts

Ref.	Part	Description	Qty.
1	241902	ELEVATOR, assembly 300 gallon	1
3	C58306	PLATE, adjuster	2
4	C58361	BRACKET, support	2
5	C20450	U-BOLT	4
6	196073	CLAMP	8
7	15D133	CLAMP, support	4
8	517272	CLAMP, support	2
9	100132	WASHER, flat	12
10	C12509	TUBE, nylon	64 ft.
11	195319	PANEL, pneumatic layout	1
12	158585	NIPPLE	2
13	24Y227	PUMP, 47:1 stainless steel (248306, 248307, 249339, 249340, 253676, 253677 only)	1
	24Y228	PUMP, 47:1 stainless steel (248982, 258910, 258911 only)	1
	24Y192	PUMP, 35:1 stainless steel (249152, 249153, 249341, 249342, 234972, 234973, 258956, 258957 only)	1
14	C51238	U-BOLT	6
15	101566	NUT, lock	6
16	517288	TUBE, coiled	2
17	241844	BRACKET, mounting	2
18	C38457	COUPLING, reducing	2
19	106464	TEE, pipe	2
20	C20463	NIPPLE, reducing, hex	3
21	C57799	VALVE, check 1/2 in.	1
22	C19019	UNION, swivel	3
23	C38324	ELBOW, street	2
	119900	ELBOW, street (234972, 234973, 253676, 253677, 258910, 258911, 258956, 258957 only)	2
24	196085	COVER, left	1
25	C20811	SCREW, socket head, flat	12
26	C20490	NIPPLE, hex	7
	119893	NIPPLE, hex (234972, 234973, 253676, 253677, 258910, 258911, 258956, 258957 only)	7
27	246929	VALVE, check	2
	234960	VALVE, check (234972, 234973, 253676, 253677, 258910, 258911, 258956, 258957 only)	2
29	C12039	HOSE, air	1
30	C19032	UNION, swivel	3
31	111803	SCREW, cap, hex	8
33	109495	O-RING	2
34	115438	VALVE, ball	1
35	109570	WASHER	8

Ref.	Part	Description	Qty.
36	214656	HOSE, coupled, 10 ft.	1
37	C19381	ELBOW, tube, (m)	1
38	054139	TUBE, nylon	4
39	C19200	WASHER	4
40	C19124	SCREW, cap, hex	4
41	C19126	SCREW, cap, hex	4
42	517254	CLIP, tube	3
43	110299	RIVET, blind	3
44	106149	FILTER, air, 1/2 npt	1
45	521975	UNION, pipe	2
	234963	UNION, pipe (234972, 234973, 253676, 253677, 258910, 258911, 258956, 258957 only)	2
46	118854	VALVE, ball	4
47	24Y228	PUMP, 47:1 stainless steel (248306, 248307, 249339, 249340, 253676, 253677 only)	1
	24Y227	PUMP, 47:1 stainless steel (248982, 258910, 258911 only)	1
	24Y206	PUMP, 35:1 stainless steel (249152, 249153, 249341, 249342, 234972, 234973, 258956, 258957 only)	1
48	100307	NUT, hex	12
49	100133	WASHER, lock	20
50	617200	BRACKET, support	1
52	112698	SWIVEL, elbow (m)	4
53	196084	COVER, right	1
54	C52751	PLATE, limit switch	1
55	C19810	SCREW, cap	2
56	195454	BRACKET, limit	1
57	C19197	WASHER	4
58	C19204	WASHER, lock	4
59	C20003	SCREW, cap	4
60	C07431	CONNECTOR, sealed	2
61	104227	NUT, lock	2
62	C19138	SCREW, cap, hex	2
63	100016	WASHER, lock	6
64	100018	WASHER, lock spring	2
65	C07560	SWITCH, limit, with arm	2
66	15D140	MANIFOLD, three-way (249341, 249342, 249152, 249153, 248306, 248307, 249339, 249340 only)	1
	15G091	MANIFOLD, three-way (234972, 234973, 258910, 258911, 258956, 258957, 253676, 253677 only)	1

Ref.	Part	Description	Qty.
67	C19491	TEE, fitting, 1-1/4 npt(f)	1
	119901	TEE, fitting, 1-1/4 npt(f) (234972, 234973, 258910, 258911, 258956, 258957, 253676, 253677 only)	1
68	V1M350	APPLICATOR, ball seat, 1/2 in.	1
69	C20485	NIPPLE, hex	1
	114373	NIPPLE, hex (234972, 234973, 253676, 253677, 258910, 258911, 258956, 258957, 253676, 253677 only)	3
70	156172	COUPLING, hex pipe	1
	15G092	COUPLING, hex pipe (234972, 234973, 253676, 253677, 258910, 258911, 258956, 258957 only)	1
71	234558	HOSE, coupled	1
	234962	HOSE, coupled (234972, 234973, 253676, 253677, 258910, 258911, 258956, 258957 only)	1
72	C19661	FITTING, 1-1/4 x 1/2 in.	1
	119896	FITTING, 1-1/4 x 1/2 in. (234972, 234973, 253676, 253677, 258910, 258911, 258956, 258957 only)	1
73	C19213	WASHER, lock	10
74	C19185	NUT, jam hex	4
76	234428	HOSE, coupled	2
	234961	HOSE, coupled (234972, 234973, 253676, 253677, 258910, 258911, 258956, 258957 only)	2
77	243255	KIT, accessory, PLC interface (248306, 248307, 249152, 249153, 234972, 234973, 253676, 253677 only)	1
	24V775	KIT, accessory, PLC interface (249339, 249340, 249341, 249342, 258910, 258911, 258956, 258957 only)	1
79	114158	ADAPTER, fitting	1
80	195356	KIT, accessory	1
81	158555	NIPPLE, reducing	2
82	113332	VALVE, ball	2
83	112859	FILTER, air	1
84	501014	ACTUATOR, air	2
85	104172	FITTING, 1/8NPT x 1/4 tube	4
86	17E556	FITTING, elbow, female	4
87	617202	MANIFOLD, air bracket	1
88	617337	COLLAR, clamp	4
89	C19800	SCREW, cap, socket head	4

Ref.	Part	Description	Qty.
90	617338	BRACKET, mounting	2
91	517455	SWITCH	2
92	C56572	CABLE	2
93	196510	COUPLING, housing	2
94	119417	SCREW	2
95	516102	CLAMP, pipe	1
96	114508	NIPPLE	1
97	233041	PLATE, ram, Neoprene	4
98	617180	ROD, connecting	8
99	101535	NUT	8
100	101533	WASHER, spring lock	1
101	617204	CARRIAGE, weldment, 300 gallon	2
102	100549	ELBOW, street	2
103	C20461	NIPPLE, reducing, hex	2
104	515147	REGULATOR, air, 1/2p	2
107	115419	ADAPTER, fitting	2
108	214849	LUBRICATOR	2
109	517290	HOSE	2
110	C19438	ELBOW, fitting, 90°	1
111	16U204	TUBE, unidrum, air inlet	1
112	114112	CONNECTOR, fitting (f)	2
113	113093	CONNECTOR, pipe	2
114	C20378	BRANCH, fitting	2
115	100469	SCREW, cap, hex	2
116	502526	VALVE, air three-way	2
117	246994	VALVE, pressure, bleed	1
119	C20487	NIPPLE, hex, 3/4-14 npt	1
120	206996	FLUID, TSL, 1 gal	1
121	617569	FITTING, reducer, plug-in	2
122	15D936	FITTING, male connector, 1/2 npt x 5/8-12	2
123	16U212	CLAMP, 1.25 in. OD pipe	1
124	94/0398/99	FITTING, 90°, 1" NPT	2
130	103347	VALVE, safety, 100 psi	2
131▲	15J074	LABEL, safety, crush and pinch	2
132▲	15M511	LABEL, warning	1
133	---	PINS, safety, kit, see page 86	1

▲ Replacement safety labels, tags, and cards are available at no cost.

**24U642 - 35:1 Left Hand Supply Unit**

**24U643 - 35:1 Right Hand Supply Unit**

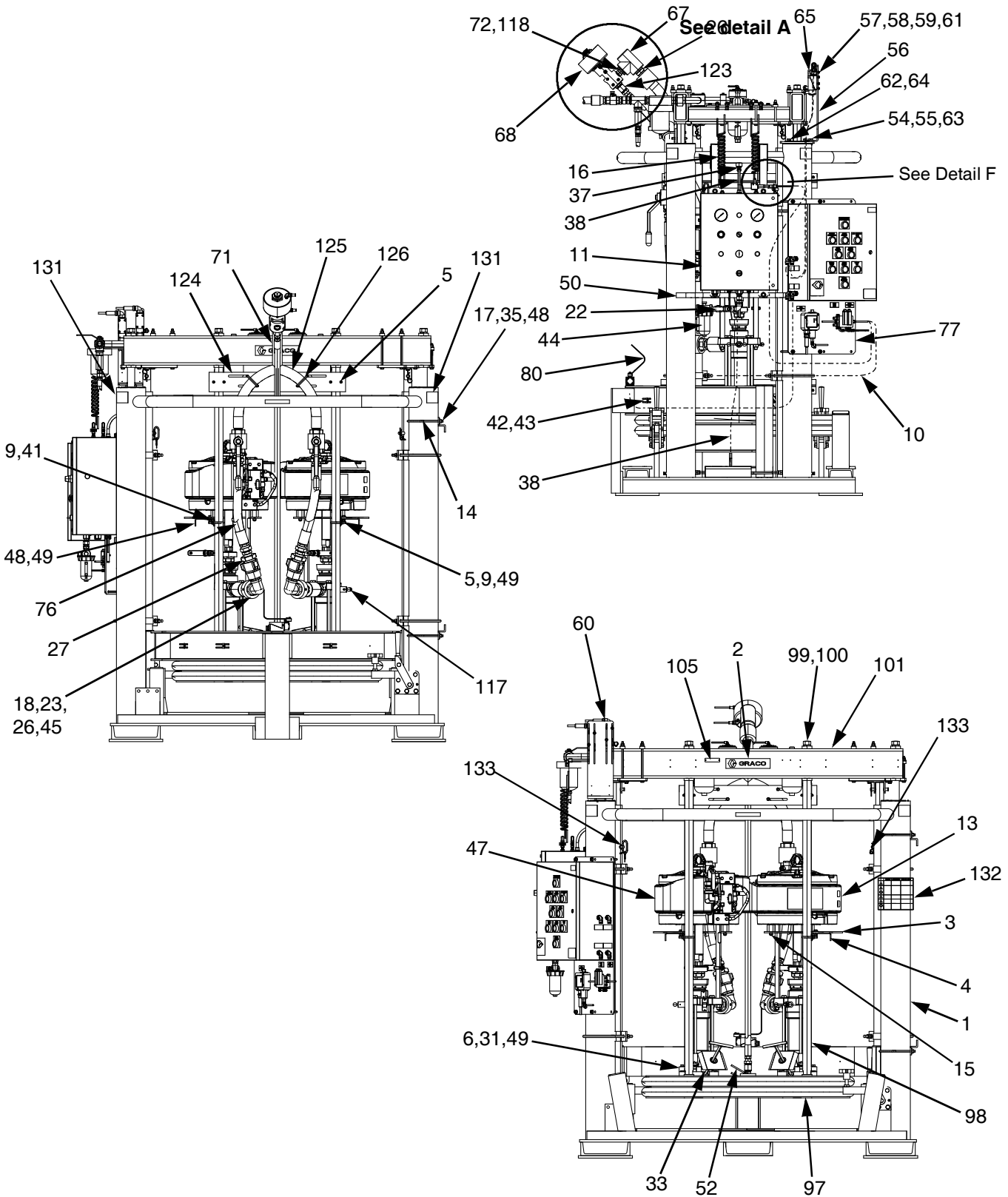

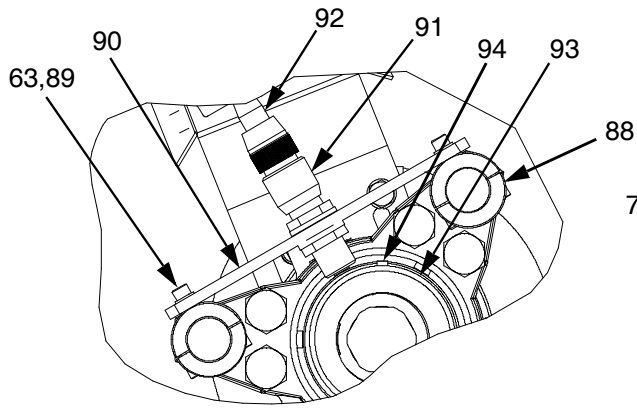

**Detail B**

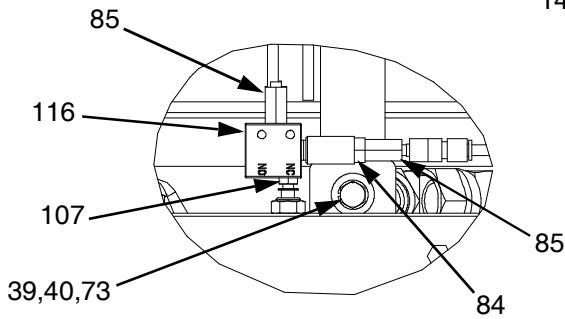
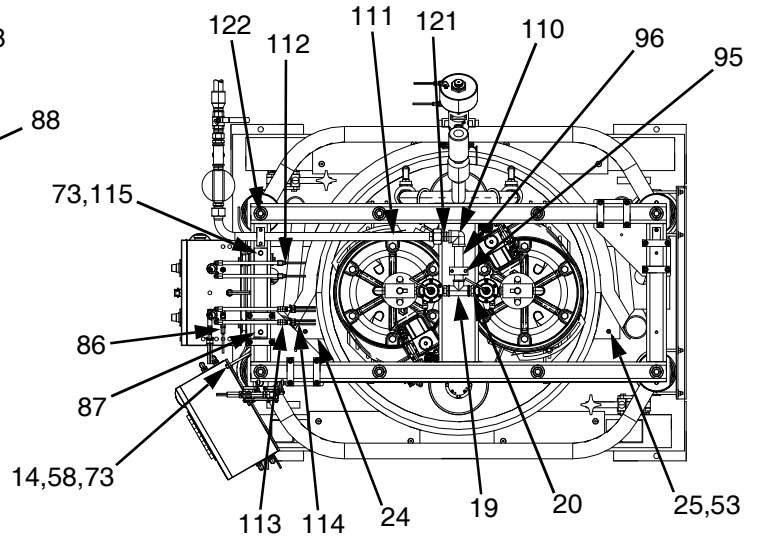

**Detail F**

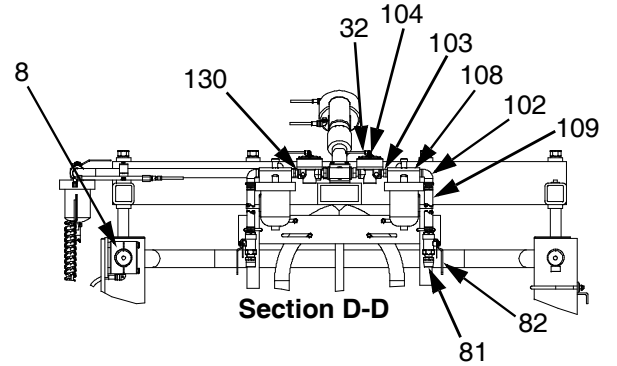

**Section D-D**

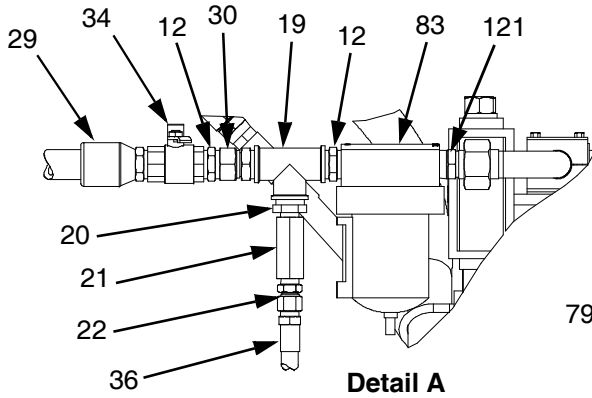

**Detail A**

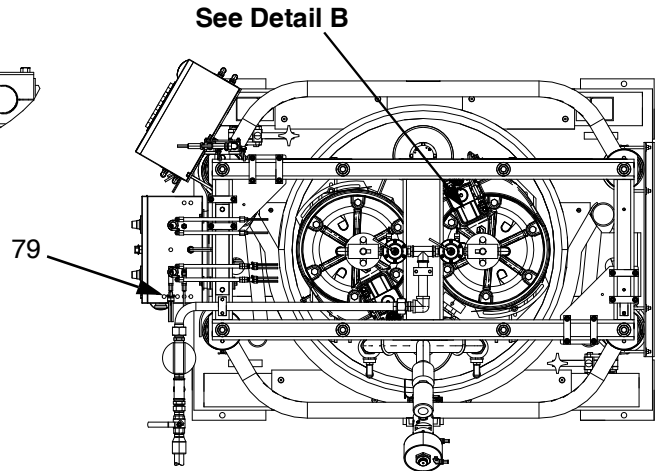

**See Detail B**

## Parts

Ref.	Part	Description	Qty.
1	241902	ELEVATOR, assembly 300 gallon	1
3	C58306	PLATE, adjuster	2
4	C58361	BRACKET, support	2
5	C20450	U-BOLT	4
6	196073	CLAMP	8
7	15D133	CLAMP, support	4
8	517272	CLAMP, support	2
9	100132	WASHER, flat	12
10	C12509	TUBE, nylon	64 ft.
11	195319	PANEL, pneumatic layout	1
12	158585	NIPPLE	2
13	24Y192	PUMP, 35:1 stainless steel	1
14	C51238	U-BOLT	6
15	101566	NUT, lock	6
16	517288	TUBE, coiled	2
17	241844	BRACKET, mounting	2
18	119899	COUPLING, reducing, sst	2
19	106464	TEE, pipe	2
20	C20463	NIPPLE, reducing, hex	3
21	C57799	VALVE, check 1/2 in.	1
22	C19019	UNION, swivel	3
23	119900	ELBOW, street, sst	2
24	196085	COVER, left	1
25	C20811	SCREW, socket head, flat	12
26	119893	NIPPLE, hex, sst	7
27	234960	VALVE, check, sst	2
29	C12039	HOSE, air	1
30	C19032	UNION, swivel	3
31	111803	SCREW, cap, hex	8
33	109495	O-RING	2
34	115438	VALVE, ball	1
35	109570	WASHER	8
36	214656	HOSE, coupled, 10 ft.	1
37	C19381	ELBOW, tube, (m)	1
38	054139	TUBE, nylon	4
39	C19200	WASHER	4
40	C19124	SCREW, cap, hex	4
41	C19126	SCREW, cap, hex	4
42	517254	CLIP, tube	3
43	110299	RIVET, blind	3
44	106149	FILTER, air, 1/2 npt	1
45	234963	UNION, pipe, sst	2
46	118854	VALVE, ball	4
47	24Y206	PUMP, 35:1 stainless steel	1
48	100307	NUT, hex	12
49	100133	WASHER, lock	20
50	617200	BRACKET, support	1
52	112698	SWIVEL, elbow (m)	4

Ref.	Part	Description	Qty.
53	196084	COVER, right	1
54	C52751	PLATE, limit switch	1
55	C19810	SCREW, cap	2
56	195454	BRACKET, limit	1
57	C19197	WASHER	4
58	C19204	WASHER, lock	4
59	C20003	SCREW, cap	4
60	C07431	CONNECTOR, sealed	2
61	104227	NUT, lock	2
62	C19138	SCREW, cap, hex	2
63	100016	WASHER, lock	6
64	100018	WASHER, lock spring	2
65	C07560	SWITCH, limit, with arm	2
66	94/0398/99	FITTING, 90°, 1" NPT	2
67	119901	TEE, fitting, 1-1/4 npt(f), sst	1
68	V1M350	APPLICATOR, ball seat, 3/4 in.	1
69	114373	NIPPLE, hex, sst	3
71	24U667	HOSE, coupled, sst	1
72	127119	BUSHING, reducing, sst	1
73	C19213	WASHER, lock	10
76	24U666	HOSE, coupled, sst	2
77	24V775	KIT, accessory, PLC interface	1
79	114158	ADAPTER, fitting	1
80	195356	KIT, accessory	1
81	158555	NIPPLE, reducing	2
82	113332	VALVE, ball	2
83	112859	FILTER, air	1
84	501014	ACTUATOR, air	2
85	104172	FITTING, 1/8NPT x 1/4 tube	4
86	17E556	FITTING, elbow, female	4
87	617202	MANIFOLD, air bracket	1
88	617337	COLLAR, clamp	4
89	C19800	SCREW, cap, socket head	4
90	617338	BRACKET, mounting	2
91	517455	SWITCH	2
92	C56572	CABLE	2
93	196510	COUPLING, housing	2
94	119417	SCREW	2
95	516102	CLAMP, pipe	1
96	114508	NIPPLE	1
97	233041	PLATE, ram, Neoprene	4
98	617180	ROD, connecting	8
99	101535	NUT	8
100	101533	WASHER, spring lock	1
101	617204	CARRIAGE, weldment, 300 gallon	2
102	100549	ELBOW, street	2
103	C20461	NIPPLE, reducing, hex	2

Ref.	Part	Description	Qty.
104	515147	REGULATOR, air, 1/2p	2
107	115419	ADAPTER, fitting	2
108	214849	LUBRICATOR	2
109	517290	HOSE	2
110	C19438	ELBOW, fitting, 90°	1
111	16U204	TUBE, unidrum, air inlet	1
112	114112	CONNECTOR, fitting (f)	2
113	113093	CONNECTOR, pipe	2
114	C20378	BRANCH, fitting	2
115	100469	SCREW, cap, hex	2
116	502526	VALVE, air three-way	2
117	246994	VALVE, pressure, bleed	1
118	190724	NIPPLE, hex, sst	1
120	206996	FLUID, TSL, 1 gal	1
121	617569	FITTING, reducer, plug-in	2
122	15D936	FITTING, male connector, 1/2 npt x 5/8-12	2
123	16U212	CLAMP, 1.25 in. OD pipe	1
124	617203	BAR, support	1
125	517284	MANIFOLD, y-pipe	1
126	C20449	BOLT, U	2
127	16F241	FITTING, adapter	1
130	103347	VALVE, safety, 100 psi	2
131▲	15J074	LABEL, safety, crush and pinch	2
132▲	15M511	LABEL, warning	1
133	---	PINS, safety, kit, see page 86	1

▲ Replacement safety labels, tags, and cards are available at no cost.

- 232729, 47:1 Left Hand Supply Unit, with carbon steel pump**
- 232839, 47:1 Left Hand Supply Unit, with stainless steel and ceramic pump**
- 232730, 47:1 Right Hand Supply Unit, with carbon steel pump (shown)**
- 232840, 47:1 Right Hand Supply Unit, with stainless steel and ceramic pump**
- 246921, 47:1 Right Hand Supply Unit, with stainless steel pump**
- 246922, 47:1 Left Hand Supply Unit, with stainless steel pump**
- 255666, 47:1 Left Hand Supply Unit, with carbon steel pump**
- 255665, 47:1 Right Hand Supply Unit, with carbon steel pump**

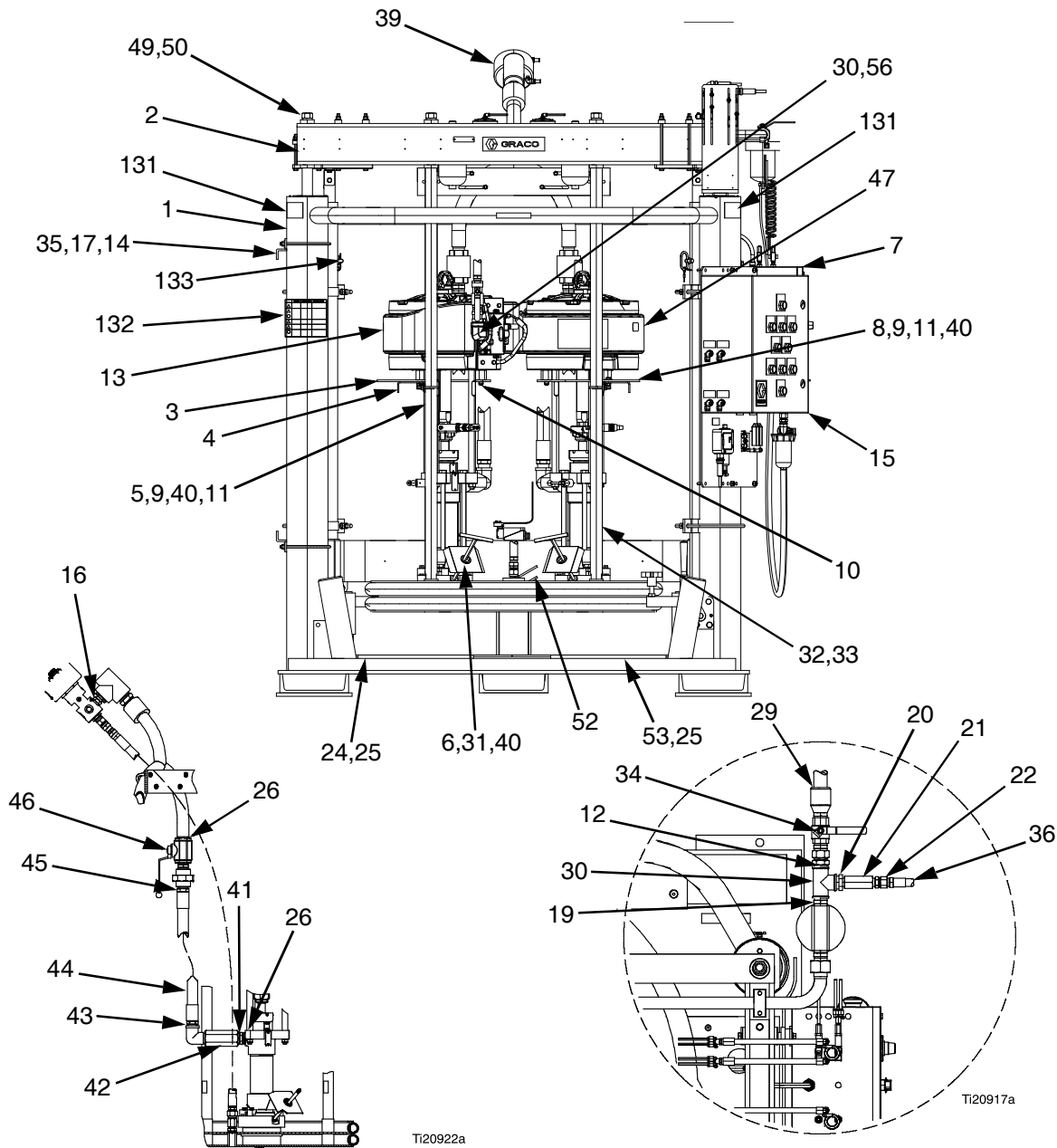



Ref.	Part	Description	Qty.
1	241902	ELEVATOR, assembly 300 gallon; see page 88	1
2	241891	FOLLOWER PLATE ASSY; (232729, 232839, 246921, 255666 only) see page 84	1
	243510	FOLLOWER PLATE ASSY; (232730, 232840, 246922, 255665 only) see page 84	1
3	C58360	PLATE, adjuster, Uni-Drum	2
4	C58361	BRACKET, pump support	2
5	C20450	U-BOLT	4
6	196073	CLAMP	8
7	241837	KIT, accessory, pneumatic; see page 72	1
8	C19126	SCREW, cap hex head	4
9	100132	WASHER, flat	16
10	101566	NUT, lock	6
11	100307	NUT, hex; 3/8-16	12
12	158585	NIPPLE	1
13	24Y211	PUMP, 47:1; carbon steel; (232729, 232730, 255665, 255666 only; see manual 308147)	2
	24Y221	PUMP, 47:1; stainless steel and ceramic (232839, 232840 only; see manual 308148)	2
	24Y225	PUMP, 47:1; stainless steel; (246921, 246922 only; see manual 308148)	2
14	C51238	U-BOLT; 6 in. tube x 1/2-13un	4
15	241838	KIT, accessory, PLC interface; see page 80 (232729, 232730, 232839, 232840 only)	1
	24V775	KIT, accessory, PLC interface; see page 80 (255665, 255666 only)	1
16	241840	KIT, accessory, depressurization; see page 71	1
17	241844	BRACKET, mounting	2
19	106464	TEE, pipe; 1 in. npt	1
20	C20463	NIPPLE, fitting hex reducing; 1 in.	1
21	C57799	VALVE, check; 1/2 npt (fbc)	1
22	C19019	FITTING, union, swivel	2
24	196085	COVER, left	1
25	C20811	SCREW, socket, flat head	12
26	C20490	FITTING, nipple, hex	2
29	C12039	HOSE, air; 1 in. ID	1
30	C19032	SWIVEL, adapter, union	3

Ref.	Part	Description	Qty.
31	111803	SCREW, cap, hex head	8
32	184086	GASKET	2
33	109495	O-RING	1
34	115438	VALVE, ball; 1 in. locking	1
35	109570	WASHER, plain	8
36	214656	HOSE; 1/2 in ID; 10 ft long	2
39	243488	KIT, accessory; see page 74	2
40	100133	LOCKWASHER, spring; 3/8 in.	20
41	C38457	COUPLING, reducing	2
42	521850	VALVE, check	2
43	C38324	ELBOW, street	2
44	233058	HOSE, coupled	2
45	521975	UNION, pipe	2
46	118854	VALVE, ball	2
47	24Y212	PUMP, 47:1; carbon steel; (232729, 232730, 255665, 255666 only; see manual 308147)	1
	24Y222	PUMP, 47:1; stainless steel and ceramic; (232839, 232840 only; see manual 308148)	1
	24Y226	PUMP, 47:1; stainless steel; (246922, 246921 only; see manual 308148)	1
49	101535	NUT, hex; 7/8 in.	4
50	101533	LOCKWASHER, spring; 7/8 in.	4
52	112698	ELBOW, swivel; 1/8 npt	4
53	196084	COVER, right	1
54*	103347	VALVE, safety, 100 psi	2
56	94/0398/99	FITTING, 90°, 1" NPT	2
60*†	C07431	CONNECTOR, sealed	2
61*†	104227	NUT, lock	2
62*†	C07560	SWITCH, limit with arm	2
63*†	100018	WASHER, lock, spring	2
64*†	C19138	SCREW, cap, hex head	2
65*†	100016	WASHER, lock	6
66*†	C19810	SCREW, cap, socket head	2
67*†	195454	BRACKET, limit	1
68*†	C19197	WASHER, plain	4
69*†	C19204	WASHER, lock #10	4
70*†	C20003	SCREW, cap, socket head	4
71*†	C52751	PLATE, limit switch	1
72*†	104172	FITTING, limit switch	4
73*†	501014	ACTUATOR, air	2
74*†	502526	VALVE, air, 3-way	2
75*†	115419	FITTING, adapter	2

Parts

Ref.	Part	Description	Qty.
77*†	C19185	NUT, jam, hex	4
78*†	C19213	WASHER, lock	4
79*†	114158	FITTING, adapter, Y	1
80*†	C12509	TUBE, nylon	12 ft
81*†	195356	KIT, accessory	1
131▲	15J074	LABEL, safety, crush and pinch	2
132▲	15M511	LABEL, warning	1
133	---	PINS, safety, kit, see page 86	1

\* *Not Shown.*

† *Parts for 255665 and 255666 models only.*

▲ *Replacement safety labels, tags, and cards are available at no cost.*

**24N914 - 35:1 Left Hand Supply Unit**  
**24N915 - 35:1 Right Hand Supply Unit**

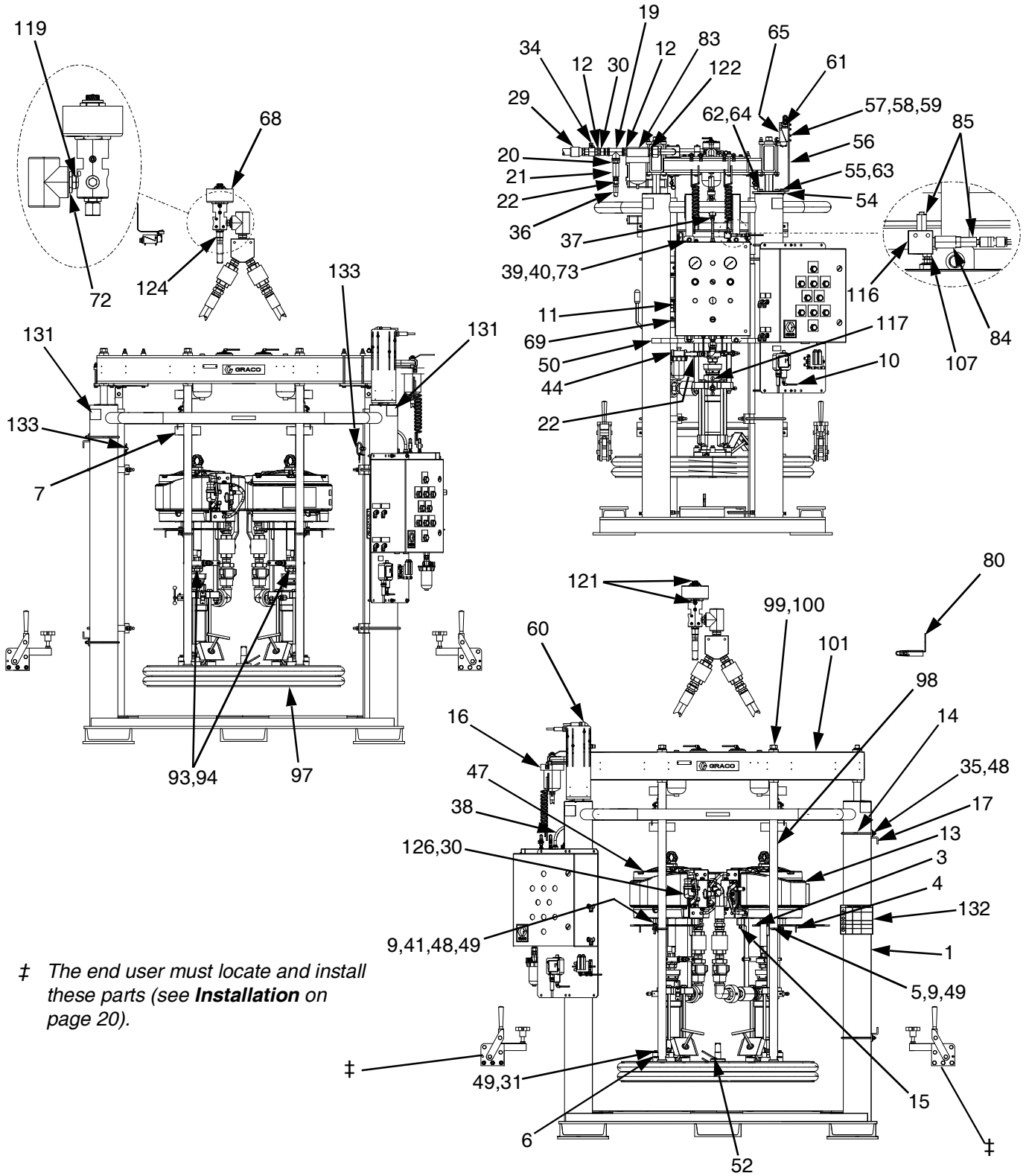

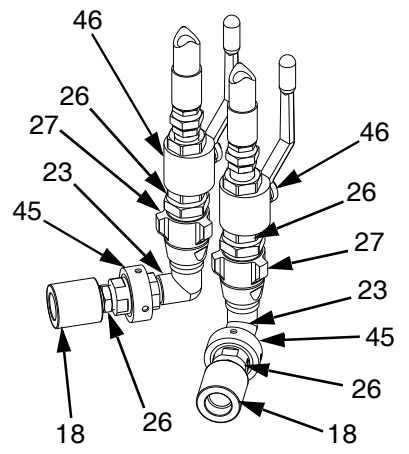
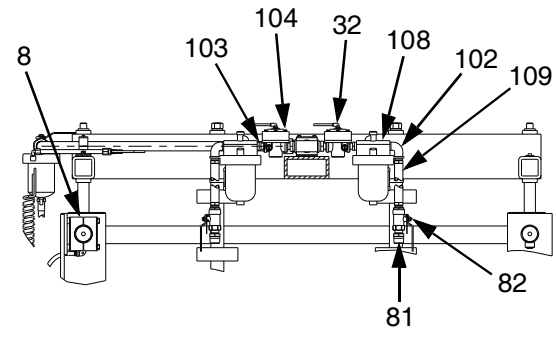
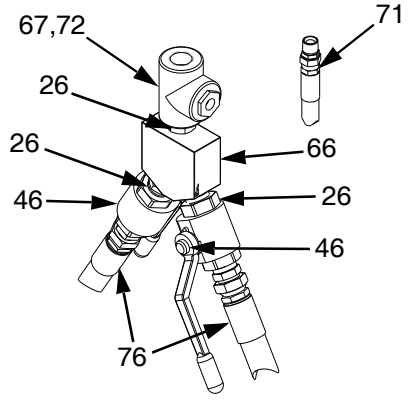
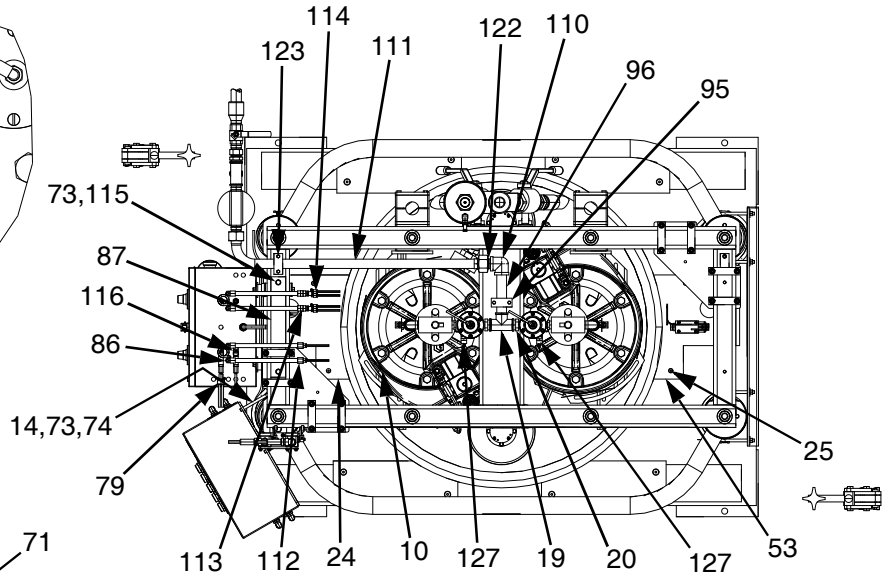
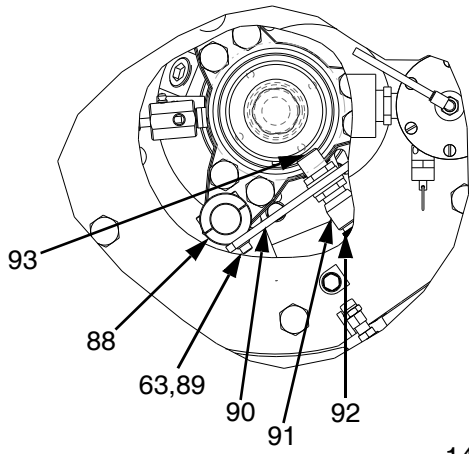

Ref.	Part	Description	Qty.
1	24M558	ELEVATOR, assembly 300 gallon	1
3	C58306	PLATE, adjuster	2
4	C58361	BRACKET, support	2
5	C20450	U-BOLT	4
6	196073	CLAMP	8
7	15D133	CLAMP, support	4
8	517272	CLAMP, support	2
9	100132	WASHER, flat	12
10	C12509	TUBE, nylon	64 ft.
11	195319	PANEL, pneumatic layout	1
12	158585	NIPPLE	2
13	24Y192	PUMP, 35:1 stainless steel	1
14	C51238	U-BOLT	6
15	101566	NUT, lock	6
16	517288	TUBE, coiled	2
17	241844	BRACKET, mounting	2
18	119899	COUPLING, reducing	2
19	106464	TEE, pipe	2
20	C20463	NIPPLE, reducing, hex	3
21	C57799	VALVE, check 1/2 in.	1
22	C19019	UNION, swivel	3
23	119900	ELBOW, street	2
24	196085	COVER, left	1
25	C20811	SCREW, socket head, flat	12
26	119893	NIPPLE, hex	7
27	234960	VALVE, check	2
29	C12039	HOSE, air	1
30	C19032	UNION, swivel	3
31	111803	SCREW, cap, hex	8
33	109495	O-RING	2
34	115438	VALVE, ball	1
35	109570	WASHER	8
36	214656	HOSE, coupled, 10 ft.	1
37	C19381	ELBOW, tube, (m)	1
38	054139	TUBE, nylon	4
39	C19200	WASHER	4
40	C19124	SCREW, cap, hex	4
41	C19126	SCREW, cap, hex	4
44	106149	FILTER, air, 1/2 npt	1
45	234963	UNION, pipe	2
46	118854	VALVE, ball	4
47	24Y206	PUMP, 35:1 stainless steel	1
48	100307	NUT, hex	12
49	100133	WASHER, lock	20
50	617200	BRACKET, support	1
52	112698	SWIVEL, elbow (m)	4
53	196084	COVER, right	1
54	C52751	PLATE, limit switch	1

Ref.	Part	Description	Qty.
55	C19810	SCREW, cap	2
56	195454	BRACKET, limit	1
57	C19197	WASHER	4
58	C19204	WASHER, lock	4
59	C20003	SCREW, cap	4
60	C07431	CONNECTOR, sealed	2
61	104227	NUT, lock	2
62	C19138	SCREW, cap, hex	2
63	100016	WASHER, lock	6
64	100018	WASHER, lock spring	2
65	C07560	SWITCH, limit, with arm	2
66	15G091	MANIFOLD, three-way	1
67	C19491	TEE, fitting, 1-1/4 npt(f)	1
68	V1M350	APPLICATOR, ball seat, 1/2 in.	1
69	114375	NIPPLE, hex	1
71	234558	HOSE, coupled	1
72	127119	FITTING, 1-1/4 x 1/2 in.	1
73	C19213	WASHER, lock	10
74	C19185	NUT, jam hex	4
76	234961	HOSE, coupled	2
77	243255	KIT, accessory, PLC interface	1
79	114158	ADAPTER, fitting	1
80	195356	KIT, accessory	1
81	158555	NIPPLE, reducing	2
82	113332	VALVE, ball	2
83	112859	FILTER, air	1
84	501014	ACTUATOR, air	2
85	104172	FITTING, 1/8NPT x 1/4 tube	4
86	17E556	FITTING, elbow, female	4
87	617202	MANIFOLD, air bracket	1
88	617337	COLLAR, clamp	4
89	C19800	SCREW, cap, socket head	4
90	617338	BRACKET, mounting	2
91	517455	SWITCH	2
92	C56572	CABLE	2
93	18A185	COUPLING, housing	2
94	119417	SCREW	2
95	516102	CLAMP, pipe	1
96	114508	NIPPLE	1
97	233041	PLATE, ram, Neoprene	4
98	617180	ROD, connecting	8
99	101535	NUT	8
100	101533	WASHER, spring lock	1
101	617204	CARRIAGE, weldment, 300 gallon	2
102	100549	ELBOW, street	2
103	C20461	NIPPLE, reducing, hex	2
104	515147	REGULATOR, air, 1/2p	2

Parts

Ref.	Part	Description	Qty.
107	115419	ADAPTER, fitting	2
108	214849	LUBRICATOR	2
109	517290	HOSE	2
110	C19438	ELBOW, fitting, 90°	1
112	114112	CONNECTOR, fitting (f)	2
113	113093	CONNECTOR, pipe	2
114	C20378	BRANCH, fitting	2
115	100469	SCREW, cap, hex	2
116	502526	VALVE, air three-way	2
117	246994	VALVE, pressure, bleed	1
118	120163	KIT, safety, lockout (not shown)	1
119	190724	NIPPLE, hex, 3/4-14 npt	1
120	206996	FLUID, TSL, 1 gal	1
121	617569	FITTING, reducer, plug-in	2
122	15D936	FITTING, male connector, 1/2 npt x 5/8-12	2
124	16F241	FITTING, adapter, 12jic x 3/4 NPT	2
127	103347	VALVE, safety, 100 psi	2
131▲	15J074	LABEL, safety, crush and pinch	2
132▲	15M511	LABEL, warning	1
133	---	PINS, safety, kit, see page 86	1

▲ Replacement safety labels, tags, and cards are available at no cost.

# Depressurization Kit, 241840

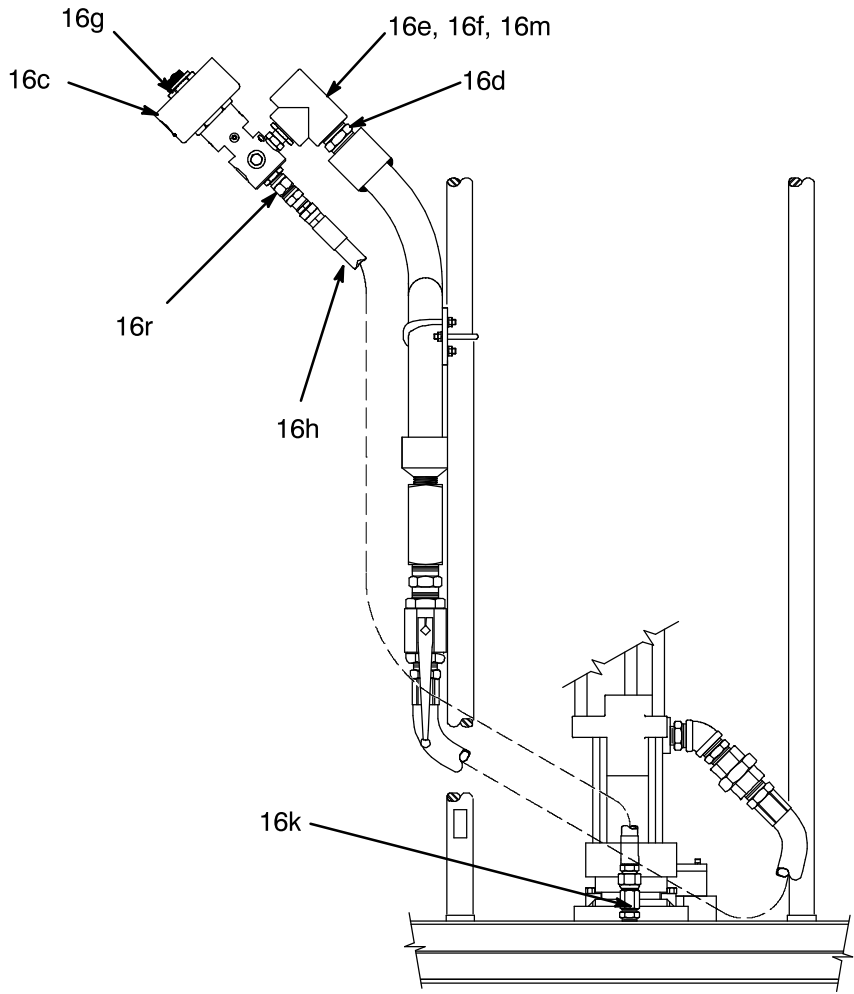

T120923a

FIG. 28

Ref.	Part	Description	Qty.
16c	V1M350	APPLICATOR, ball seat; see 3A1792 for parts	1
16d	C20490	NIPPLE	1
16e	C19661	BUSHING	1
16f	C19491	TEE	1
16g	617569	FITTING, reducer, plug-in	2
16h	236425	HOSE	1
16k	157129	NIPPLE	1
16m	C20487	NIPPLE, hex	1
16r	156172	FITTING, union, swivel	1

# Pneumatic Accessory Kit, 241837

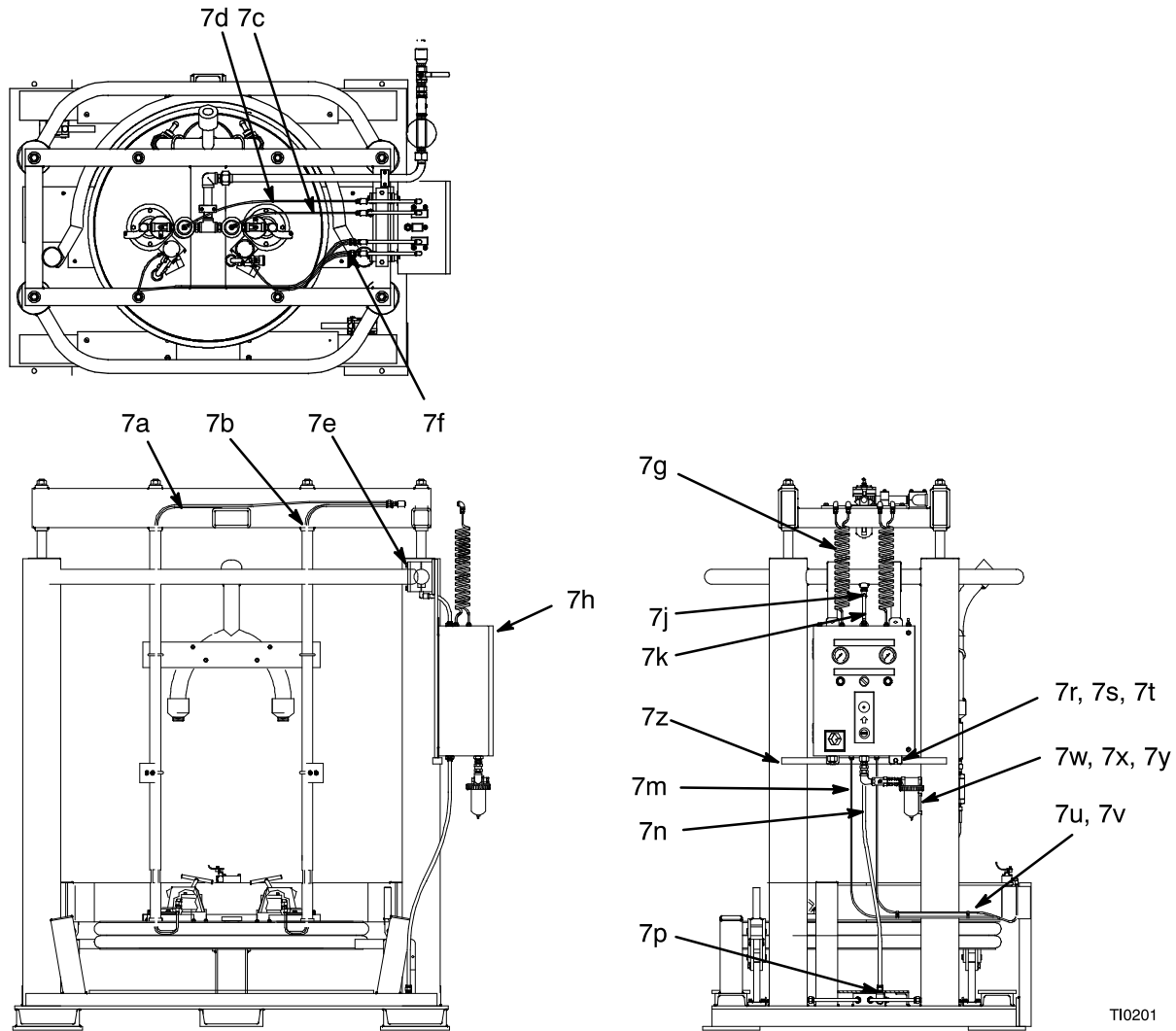

FIG. 29

Ref.	Part	Description	Qty.
7a	C12509	TUBE; nylon	248 in.
7b	C12509	TUBE; nylon	200 in.
7c	C12509	TUBE; nylon	23 in.
7d	C12509	TUBE; nylon	31 in.
7e	517272	CLAMP, support	2
7f	C20378	FITTING, Y-branch	2
7g	517288	TUBE; 1/4 in.	2
7h	24K172	PANEL, pneumatic logic; see page 77	1
7j	C19381	CONNECTOR; 1/2 npt x 1/2 in.	tube 1
7k	C12194	TUBE; 1/2 in.	8 in.
7m	C12509	TUBE; nylon	120 in.

Ref.	Part	Description	Qty.
7n	C12194	TUBE; 1/2 in.	40 in.
7p	C19399	CONNECTOR; 1/2 npt x 1/2 in. tube	1
7r	C19200	WASHER, plain	4
7s	C19124	SCREW, cap, hex hd	4
7t	C19213	WASHER, lock	4
7u	517254	CLIP, tube	3
7v	110299	RIVET	3
7w	106149	FILTER, air; 1/2 npt	1
7x	C20485	FITTING; 1/2 npt	1
7y	C19019	UNION, swivel	1
7z	617200	SUPPORT, bracket	1



# Low/Empty Limit Kit (for Uni-Drum Use), 241839

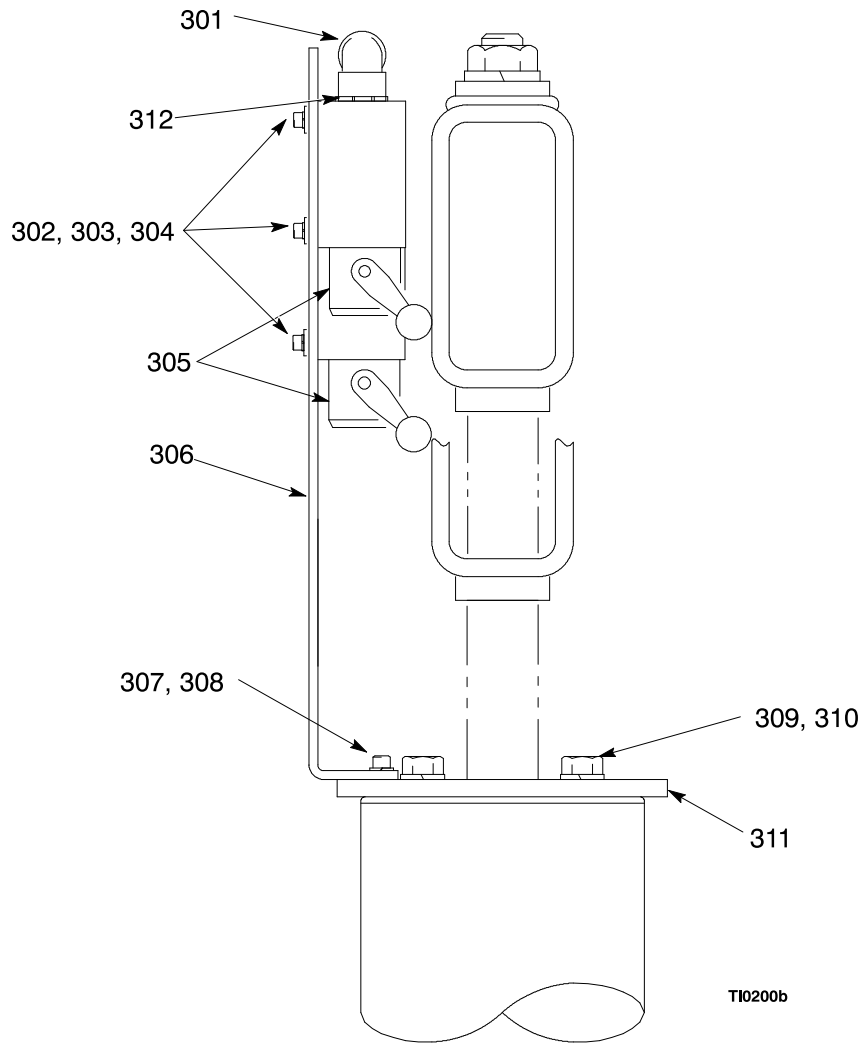
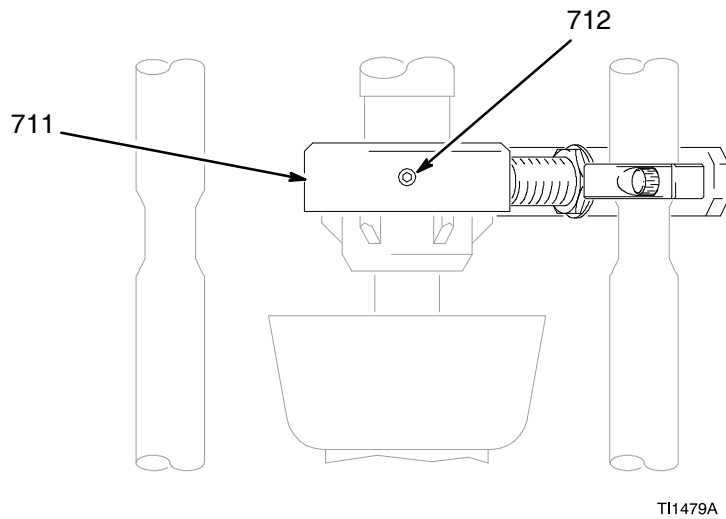
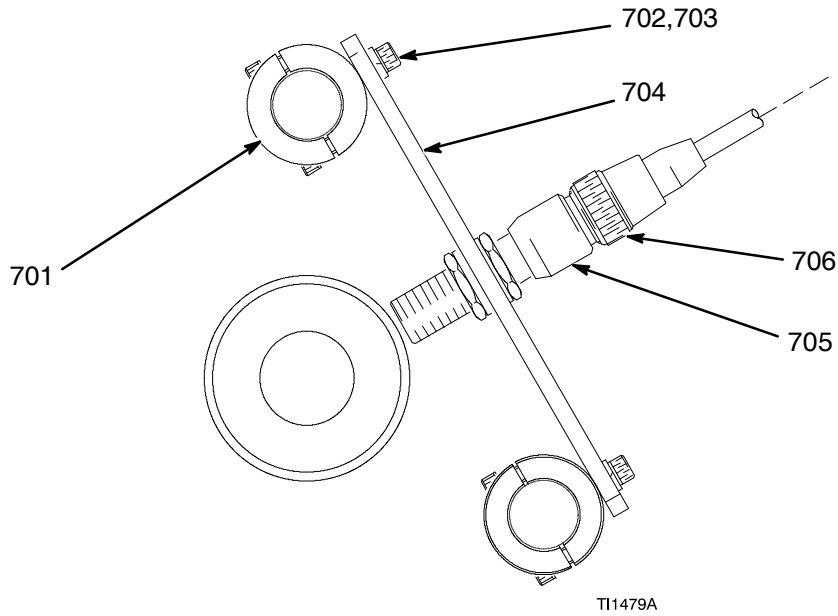

FIG. 30

Ref.	Part	Description	Qty.
301	C07431	CONNECTOR, sealed	2
302	C20003	CAPSCREW, socket head	4
303	C19204	WASHER, lock #10 bolt	4
304	C19197	WASHER, plain	4
305	C07560	SWITCH, limit	2
306	195454	BRACKET, limit, low-level, Uni-Drum	1
307	C19810	CAPSCREW, socket head	2
308	100016	WASHER, spring lock; 1/4 in.	2
309	112166	SCREW, cap, hex head	2
310	100018	LOCKWASHER, spring; 1/2 in.	2
311	C52751	PLATE, limit switch	1
312	104227	NUT, lock	2

# Proximity Switch Accessory Kit, 243488



**FIG. 31**

Ref.	Part	Description	Qty.
701	617337	COLLAR, clamp	2
702	100016	WASHER, lock; 1/4 in.	2
703	C19800	SCREW, socket hd; 1/4-20 x 1/2 in.	2
704	617338	BRACKET, proximity switch mounting	1
705	517455	SWITCH, proximity; 18 mm	1
706	C56572	CABLE, proximity; 2 m long	1
711	196510	HOUSING, coupling nut	1
712	119417	SCREW, cup point set; 1/4-20	1

# Follower Plate Assembly, 241891 and 243510

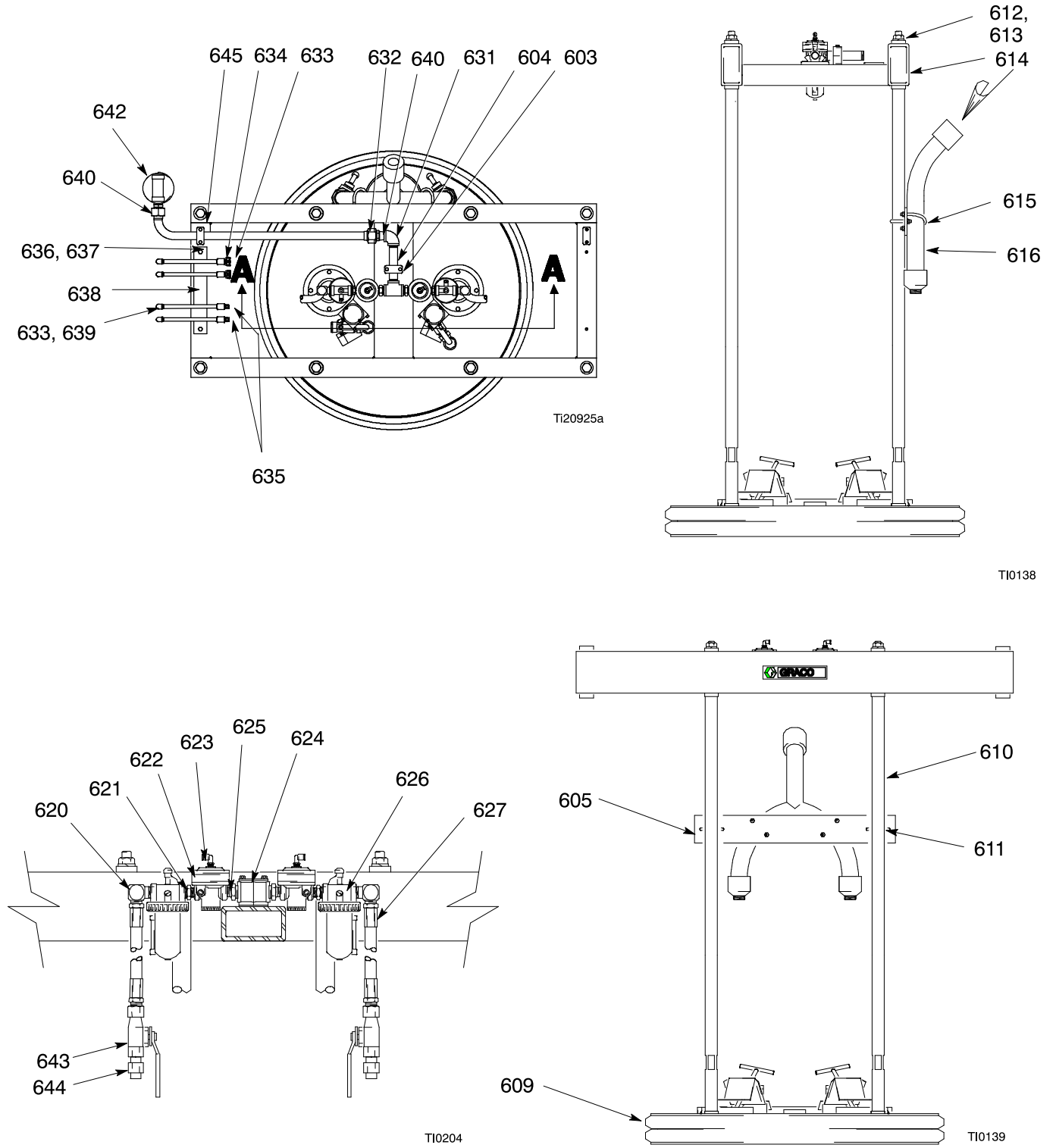

FIG. 32

## Follower Plate Assembly, 241891 and 243510

Ref.	Part	Description	Qty.
603	516102	CLAMP, pipe	2
604	114508	NIPPLE	1
605	617203	BAR, support	1
609	233041	PLATE, follower; see page 84	1
610	617180	ROD, connecting	4
611	C20450	U-BOLT	2
612	101535	NUT, hex	4
613	101533	LOCKWASHER, spring; 7/8 in.	4
614	617204	CARRIAGE	1
615	C20449	U-BOLT; 3/8-16	2
616	517284	DISCHARGE MANIFOLD	1
620	100549	ELBOW, street	2
621	C20461	NIPPLE, reducing	2
622	515147	REGULATOR	2
623	C19391	ELBOW	2
624	106464	TEE	1
625	C20463	NIPPLE, reducing	2
626	214849	LUBRICATOR, air line	2
627	517290	HOSE	2
631	C19438	ELBOW; 1 in. npt	1
632	16U204	TUBE, unidrum, air inlet	1
633	114112	CONNECTOR, female	6
634	113093	CONNECTOR, pipe	4
635	C20378	FITTING, tube, Y-branch; 1/4 npt (m) x 1/4 OD tube	2
636	100469	SCREW, cap, hex hd	2
637	C19213	WASHER, lock	2
638	617202	MANIFOLD, air	1
639	17E556	ELBOW; 1/4 npt	4
640	15D936	FITTING, male connector	2
641	158585	NIPPLE	1
642	112859	FILTER, air; 1 in. npt	1
643	113332	VALVE, ball	2
644	158555	NIPPLE, reducing	2
645	16U212	CLAMP, 1.25 in. OD, pipe	1

# PLC Pneumatic Logic Panel

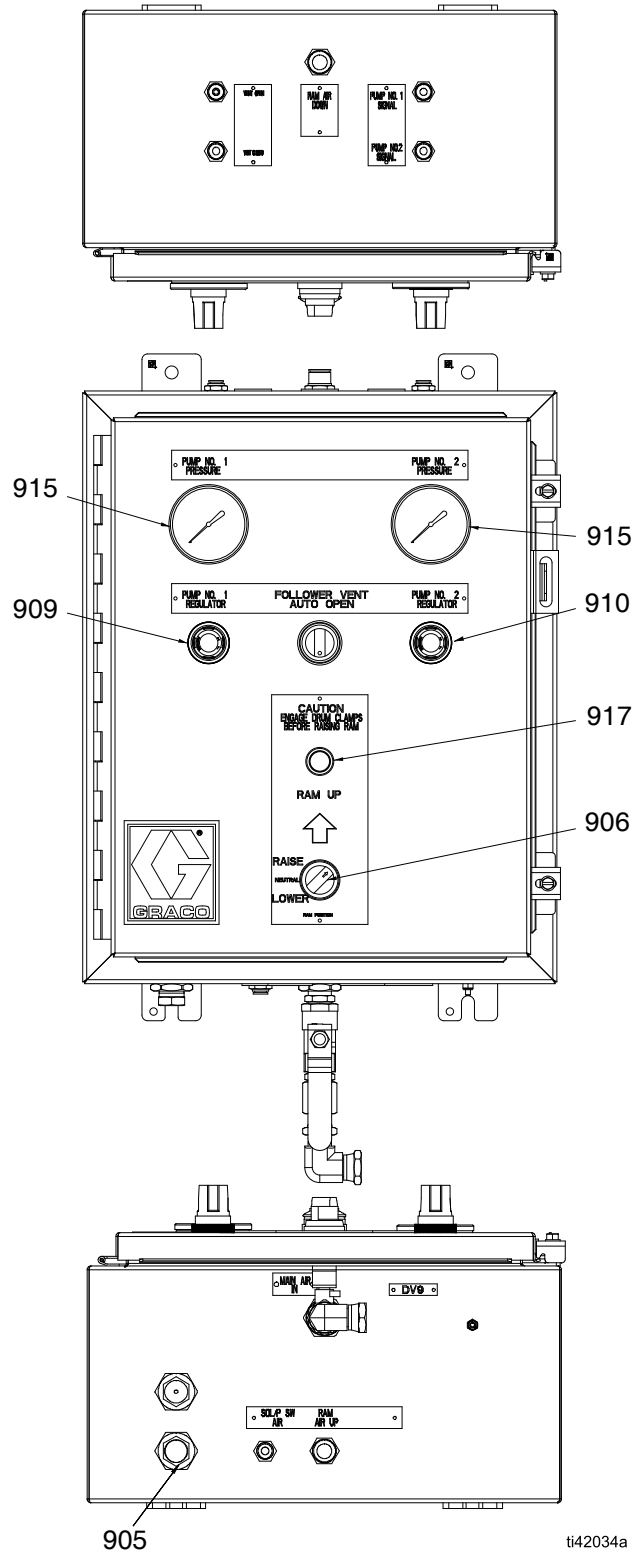
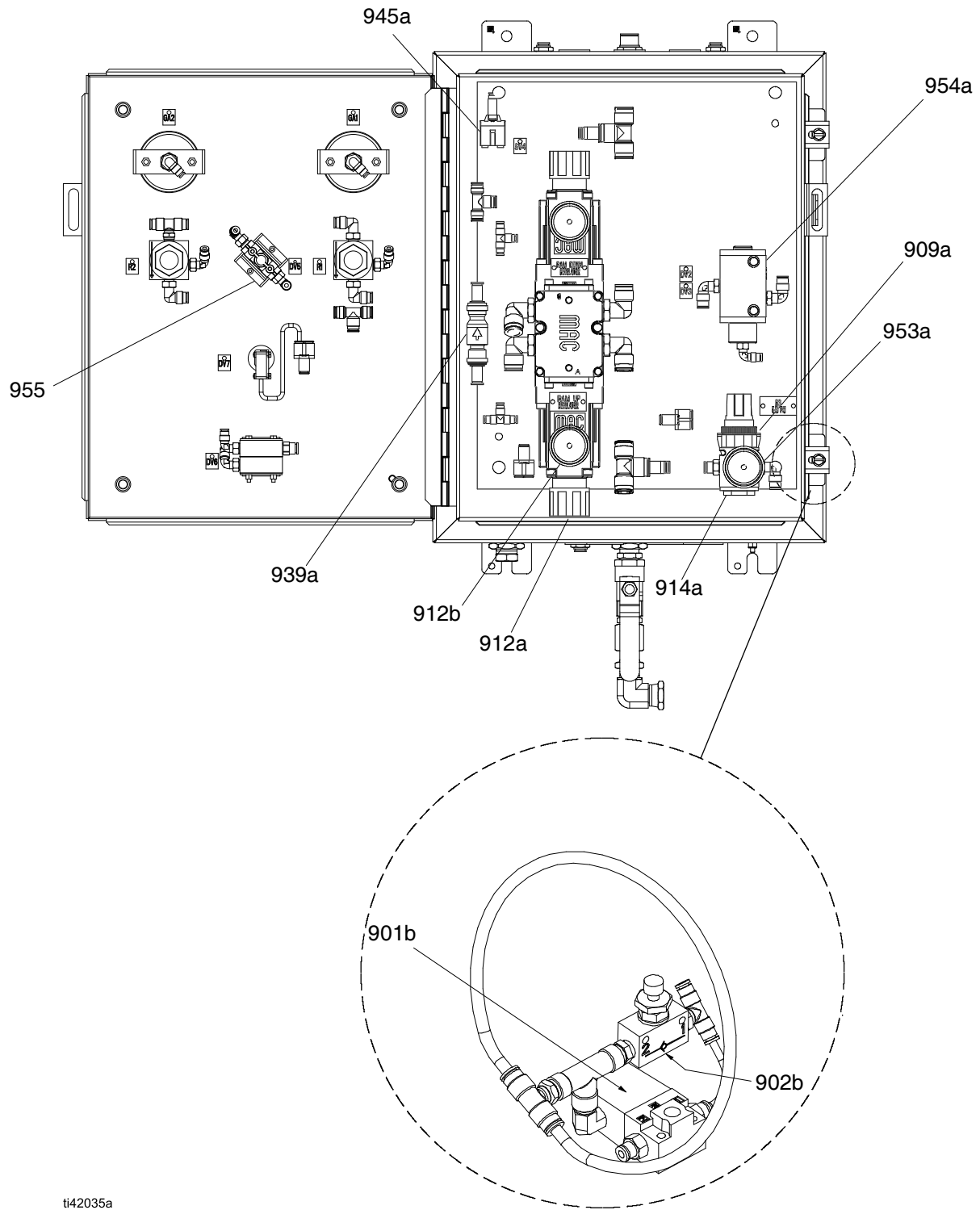

FIG. 33

ti42034a



ti42035a

FIG. 34

**PLC Pneumatic Logic Panel, 24K172**

Ref.	Part	Description	Qty.
905	125502	FITTING, PLUG, HEX, MUFFLER	1
906	125504	VALVE, PNEUMATIC, 3 POSITION	1
909	125505	NUT, PNEUMATIC, REGULATOR, PLAST	2
910	125506	VALVE, PNEUMATIC, REGULATOR	2
915	125452	GAUGE, PRESSURE, AIR, PANEL MOUNT	2
917	26D869	VALVE KIT, 3W, PB, BLK, UNI	1
955	24J876	SWITCH, PNEUMATIC, ASSEMBLY	1

**Pneumatic Panel Assembly**

Ref.	Part	Description	Qty.
909a	125505	NUT, PNEUMATIC, REGULATOR, PLAST	1
912a	517412	REGULATOR, VALVE, DUAL, 4 WAY	1
912b	127379	GAUGE, PRESSURE, AIR, 0-160 PSI	2
914a	125507	VALVE, PNEUMATIC, REGULATOR	1
939a	125501	VALVE, PNEUMATIC, CHECK, PUSH IN	1
945a	125458	SWITCH, PNEUMATIC, LOGIC	1
953a	125511	GAUGE, PRESSURE, AIR	1
954a	115793	VALVE, PILOT, 4-WAY DUAL AIR	2

**Timer Control Valve**

Ref.	Part	Description	Qty.
901b	121265	VALVE, REMOTE, AIR ACTUATED	1
902b	125409	VALVE, FLOW CONTROLLER	1

# PLC Interface Accessory Kit, 241838 and 24V775

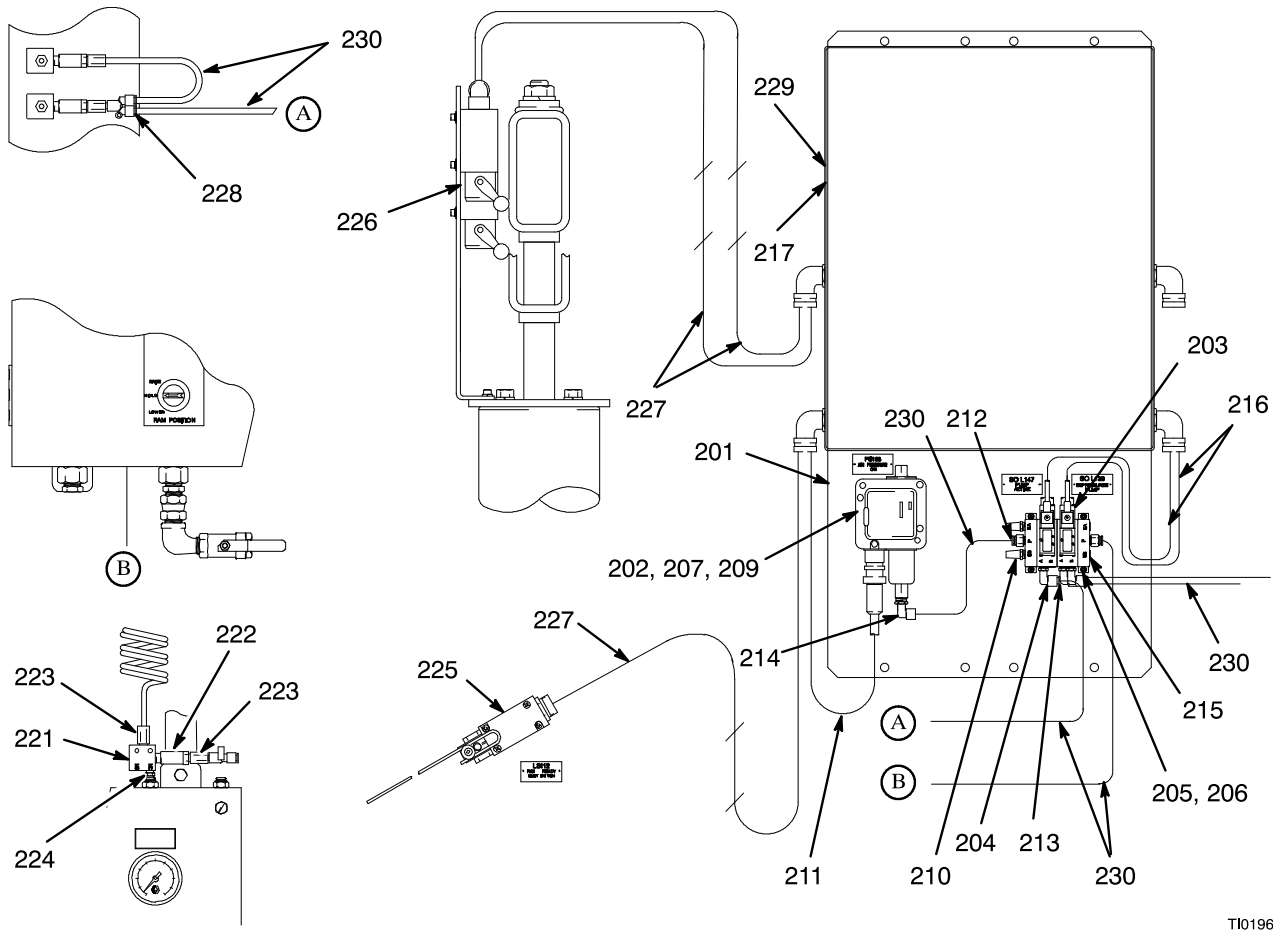

TI0196

FIG. 35



## PLC Interface Accessory Kit, 241838 and 24V775

Ref.	Part	Description	Qty.
201	195330	PLATE, mounting	1
202	C55568	SWITCH, pressure; 1/4 in. npt (241838 only)	1
	119776	SWITCH, pressure; 1/4 in. npt (24V775 only)	1
203	115440	VALVE, assembly (241838 only)	1
	119777	VALVE, assembly (24V775 only)	1
204	597151	ELBOW, male	3
205	96/0340/9	SCREW, S.H.C.; CS PL #6-32x	4
206	96/0432-1 /99	WASHER, lock; CS PL #6	4
207	596936	SCREW, S.H.C.; 1/4-20 x 1.5	2
209	100016	WASHER, lock; CS PL 1/4	2
210	517449	MUFFLER	2
211	C07434	CORD, 5-pin; 6 ft long	1
212	C19407	FITTING, tube; 1/4T x 1/8P	2
213	103219	PLUG, pipe; 1/8 npt	1
214	C19391	ELBOW, 90 degree, tube; 1/4P x 1/4	T1
215	C19254	PLUG, pipe; 1/4 npt	2
216	127366	CABLE, 2	2
217	195320	PANEL, junction box; (241838 only) see page 91.	1
	119773	PANEL, junction box; (24V755 only) see page 91.	1
218	C51238	U-BOLT; 6 in. x 3/8-16 (not shown)	2
219	C19185	JAM NUT (not shown)	4
220	C19213	WASHER, lock; 3/8 (not shown)	4
221	502526	VALVE, air	2
222	501014	ACTUATOR, air	2
223	104172	FITTING, tube	4
224	115419	FITTING, adapter	2
225	195356	KIT, accessory	1
226	241839	KIT, low/empty limit;	1
227	C07435	CORD, 5-pin; 12 ft long	3
228	114158	FITTING, adapter, Y	1
229	100157	SCREW; 10-32 X 0.38	4
230	C12509	TUBE; 1/4 in.; nylon	144 in.

# Junction Box Panel, 195320 and 119773

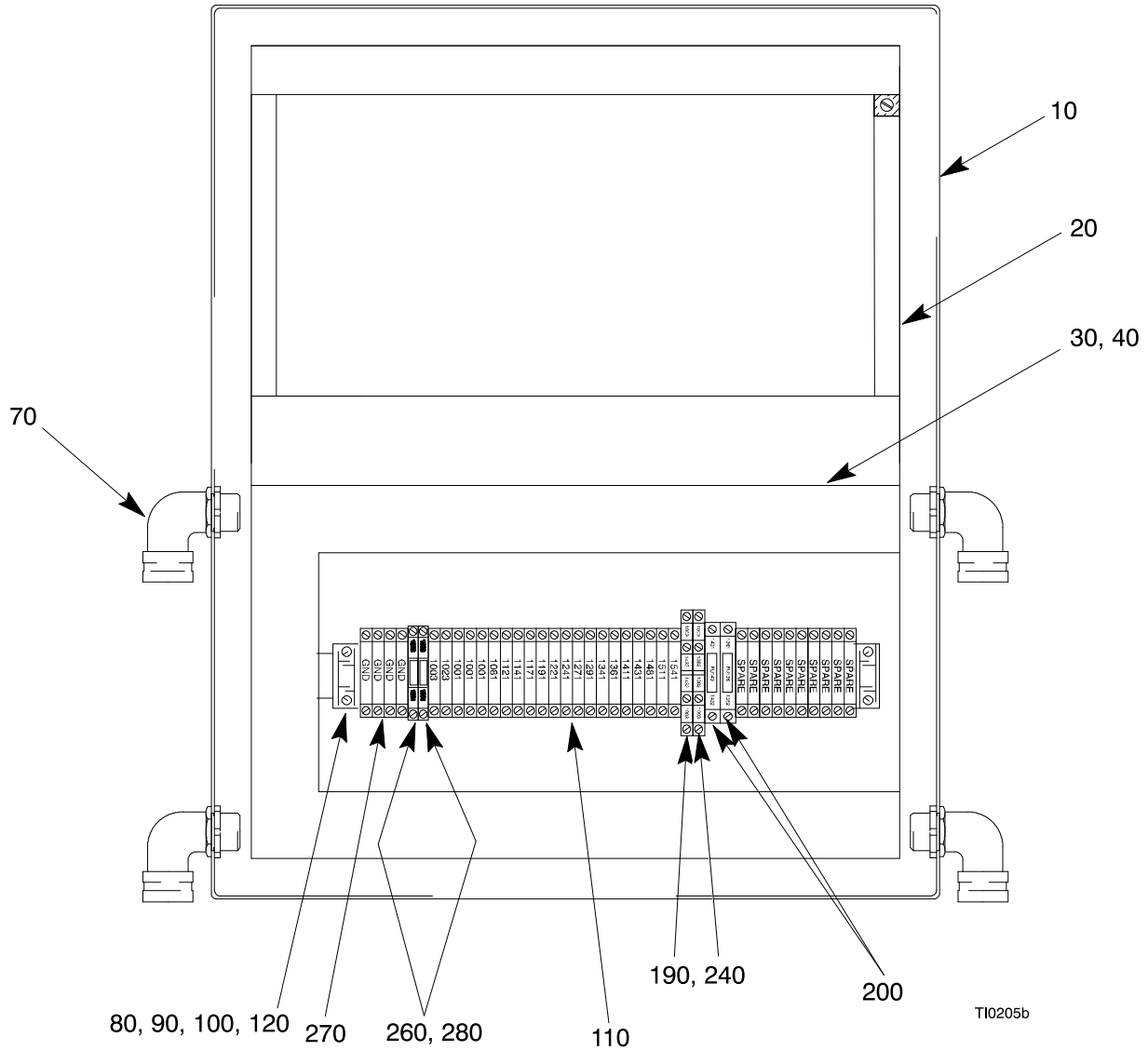

TI0205b

FIG. 36

## Junction Box Panel, 195321 and 119773

Ref.	Symbol	Description	Remark	U.L. File No.	Qty.
290	---	P-N 90 DEG. CORD GRIP DB-1090	---	---	4
280	---	A-B PB 800T-XD2	---	---	1
270	PB	A-B PB 800T FX9A1	---	---	1
260	SS	A-B SS 800T-H2A	---	---	1
250	---	BARRIER ENTRELEC 29104221	---	---	1
240	---	---	---	---	---
230	FU	BUSS FUSS GDC-250 MA 5 X 20 mm	---	---	2
220		GND ENTRELEC 0290.019.05	---	E160646	4
210	DISC	ENTRELEC 0290.041.03	K5100, 102	E40735	2
200	FU	ENTRELEC FUSE BLOCK 0115.662.22	FU136, 143	E40735	2
190	SUP	A-B SUPPRESSOR 1492-WD4SS	SUP136, 144	E40735	2
180	PB	A-B PB #800T-A2D1 (BLACK)	PB119, 122	---	2
170	PB	A-B PB #800T-A2D1 (GREEN)	PB124	---	1
160	LT	A-B LIGHT WHITE #800T-PT16W (195320 only)	LT 148	E14840-NKCR	1
	LT	A-B LIGHT WHITE #800T-QT24W (119773 only)	LT 148	E14840-NKCR	1
150	LT	A-B LIGHT BLUE #800T-PT16B (195320 only)	LT110	E14840-NKCR	1
	LT	A-B LIGHT BLUE #800T-8T24B (119773 only)	LT110	E14840-NKCR	1
140	LT	A-B LIGHT AMBER #800T-PT16A (195320 only)	LT 141	E14840-NKCR	1
	LT	A-B LIGHT AMBER #800T-QT24A (119773 only)	LT 141	E14840-NKCR	1
130	LT	A-B LIGHT GREEN #800T-PT16G (195320 only)	LT 134, 106	E14840-NKCR	2
	LT	A-B LIGHT GREEN #800T-QT24G (119773 only)	LT 134, 106	E14840-NKCR	2
120	---	A-B JUMPER 0291.103.24	---	---	AR
110	---	TERMINAL ENTRELEC 0290.011.25	---	E40735	31
100	---	ENTRELEC END BARRIER 0291.041.20	---	---	1
90	---	ENTRELEC END ANCHOR 10300226	---	---	2
80	---	A-B MOUNTING CHANNEL 1492-N44	---	---	12 in
70	---	T & B SEAL RING 5262	---	---	8
60	---	T & B LOCKNUT 141	---	---	8
50	---	P-N 90 DEG. CORD GRIP DB-890	---	---	4
40	---	TAYLOR DUCT COVER	---	---	29 in
30	---	TAYLOR WIRE DUCT (1.5 X 2)	---	---	29 in
20	---	HOFF PANEL #C-P2016	---	---	1
10	---	HOFF ENCLOSURE #C-SD20168	---	---	1

# Follower Plate, 233041

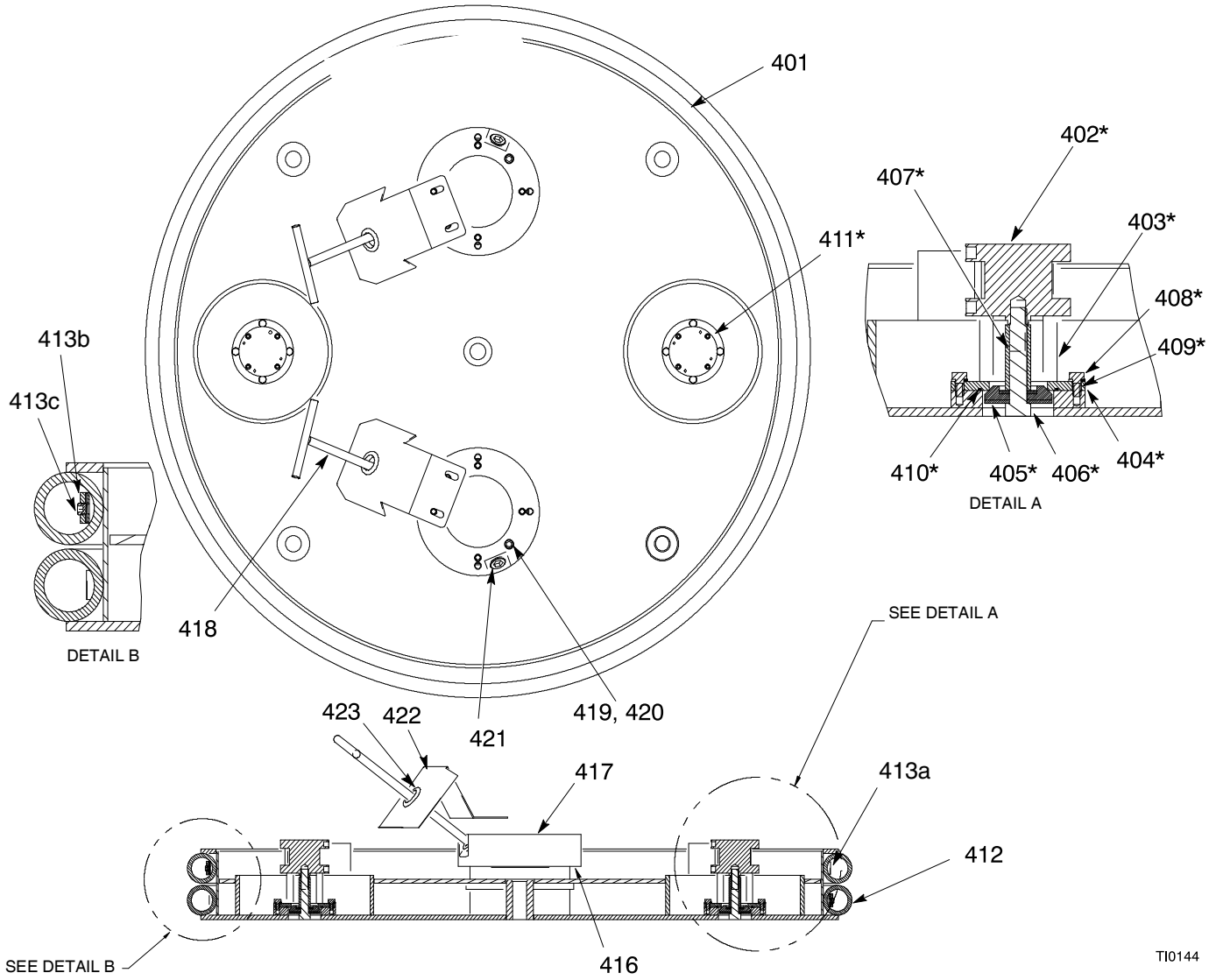

T10144

**FIG. 37**

**Follower Plate, 233041**

Ref.	Part	Description	Qty.
401	233040	PLATE, ram	1
402*	115782	CYLINDER, air	2
403*	196052	SPACER	8
404*	196053	PLATE	2
405	517286	PLUNGER	2
406*	115783	BOLT, hex hd	2
407*	196051	SPACER	2
408*	100333	SCREW, cap, hex hd	8
409*	100016	WASHER, lock; 1/4 in.	8
410*	112245	O-RING	2
411*	115784	SCREW, cap, socket hd	8
412**	617195	WIPER	2
413**	24X821	KIT, banding, seal, Uni-Drum (1 kit per wiper)	1
413a	---	STRAPPING; steel	144 in.
413b	---	CLAMP, banding	1
413c	---	SCREW, set	1
416	617230	GASKET	2
417	196072	RING, adapter	2
418	233044	PLUG, vent	2
419	C19843	CAPSCREW	4
420	106115	LOCKWASHER	4
421	102726	PLUG, pipe	2
422	196122	SHIELD	2
423	114269	GROMMET	2

\* *These parts may be purchased separately or in Kit 234958.*

\*\* *These parts may be purchased separately or in Wiper Kit, 918241.*

# Safety Pin Maintenance Kit, 26B772

Left-Handed Unit  
Shown

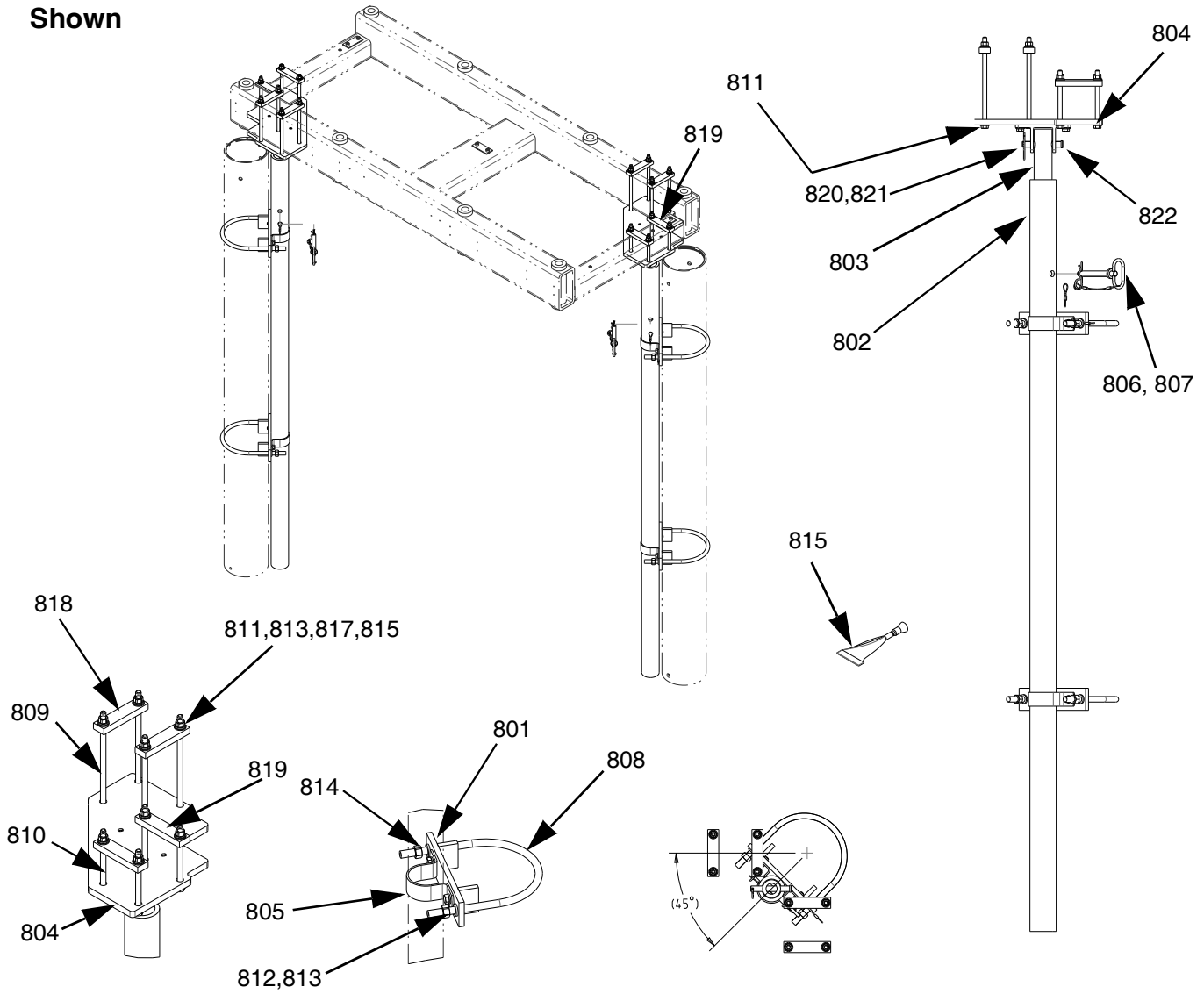
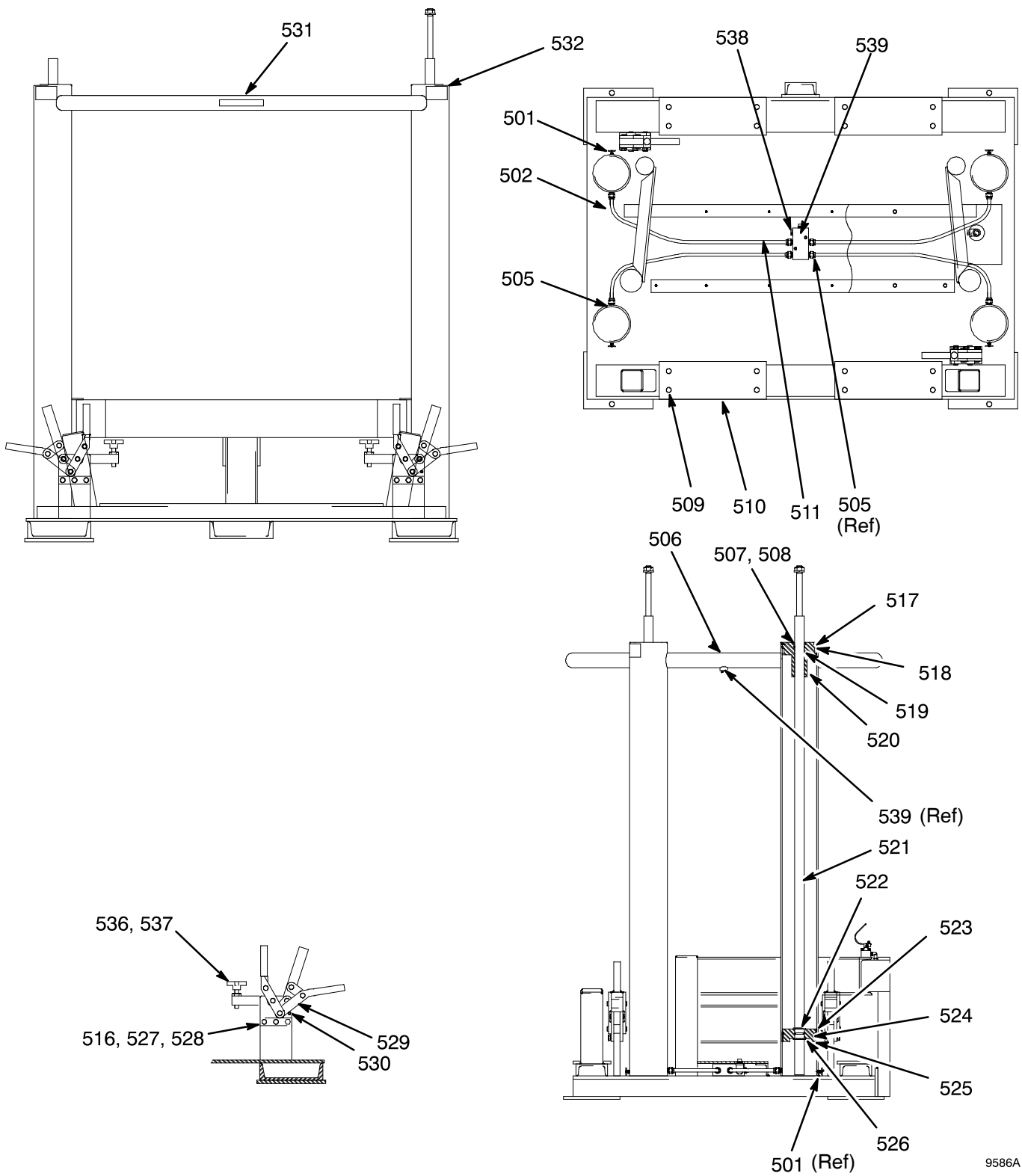

FIG. 38

**Safety Pins, 26B772**

Ref.	Part	Description	Qty.
801	26B769	BRACKET, cylinder support	4
802	18D250	TUBE, support, outer	2
803	18D251	TUBE, support, inner	2
804	18D249	PLATE, base, lock out	2
805	133303	STRAP, pipe, 2 in.	4
806	16Y456	PIN, safety, hitch	2
807	15G945	CABLE, lanyard, 24 in.	2
808	15G946	BOLT, U, 1/2 x 8.375	4
809	133306	SCREW, HHC	8
810	123389	SCREW	8
811	101971	WASHER, thrust	32
812	123284	SCREW, HHC	8
813	100133	WASHER, lock, 3/8	24
814	100018	WASHER, lock, spring, 1/2	8
815	113500	ADHESIVE, anaerobic	1
817	100307	NUT, hex	16
818	18D253	PLATE, mounting, u-bolt, 3/8	7
819	18D254	PLATE, mounting, u-bolt, 3/8, thk	1
820	18D252	BRACKET, lock out, unidrum	2
821	113802	SCREW, hex head, flanged	4
822	133305	PIN, clevis	2

# Elevator Assembly, 241902



9586A

FIG. 39



**Elevator Assembly, 241902**

Ref.	Part	Description	Qty.
501	517269	DRAIN COCK	4
502	C12194	TUBE; 1/2 in.	136 in.
505	114129	CONNECTOR, male	8
506	617206	FRAME, elevator	1
507*	C31001	WIPER, rod	4
508	C03043	RING, snap	4
509	C20808	SCREW, socket, flat-head	16
510	617179	PAD, rest	4
516	100321	NUT	6
517	C03042	RING, lock	4
518*	121306	O-RING	4
519*	156593	O-RING	4
520	C31000	SLEEVE	4
521	617176	ROD, lift	4
522	C20417	RING, retaining	8
523	C03046	PISTON, elevator	4
524*	C20280	O-RING	4
525*	C03047	GUIDE, band	4
526*	158776	O-RING	4
527	C19130	SCREW, cap, hex hd	6
528	100018	WASHER, lock	6
529	194968	CLAMP	2
530	517281	PIN, spring	2
531	C14022	LABEL, warning	2
532	C14007	LABEL, warning	4
536	100681	NUT, jam, hex	2
537	517411	KNOB	2
538	114111	CONNECTOR, male	1
539	100361	PLUG, pipe	3

\* These parts may be purchased separately or in Repair Kit 918110.

# Recommended Spare Parts

## Spare Parts for Pump and Air Motor

Refer to the appropriate manual listed in **Related Manuals** on page 3.

## Spare Parts for 47:1 and 35:1 Uni-Drum Supply Units

The customer should maintain an inventory of the spare parts (per unit) listed below.

<b>CST Units</b>	<b>SST Units</b>	<b>Description</b>	<b>Qty.</b>
515147	515147	AIR REGULATOR	1
V1M350	V1M350	RECIRCULATING VALVE KIT, see manual 3A1792	2
115440	115440	VALVE, solenoid	1
C55568	C55568	SWITCH, pressure	1
C07560	C07560	SWITCH, limit	1
102774	102774	LUBRICATOR KIT	1
517285	517285	AIR CYLINDER	1
C20247	C20247	O-RING	2
517286	517286	PLUNGER	2
C03039	C03039	UNI-DRUM ELEVATOR KIT	2
162440	162440	BOWL SEAL	1
502526	502526	PILOT VALVE	1
501014	501014	ACTUATOR	1
918110	918110	AIR CYLINDER KIT	1
918241	918241	WIPER KIT	1
234958	234958	FOLLOWER PLATE VENT VALVE KIT	1

# Electrical Diagram

## Junction Box Panel

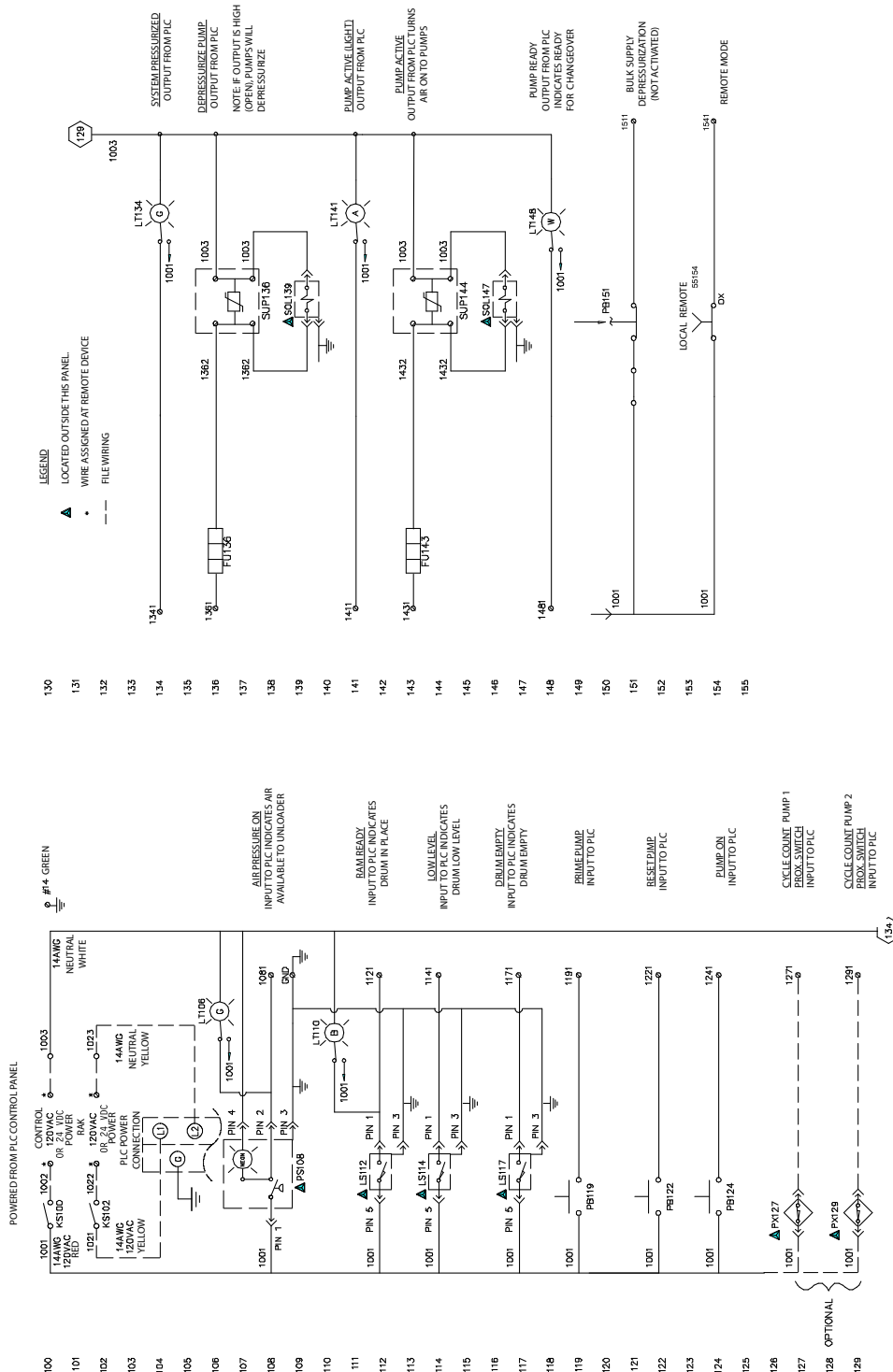

T10207

Fig. 40

# Pneumatic Diagram

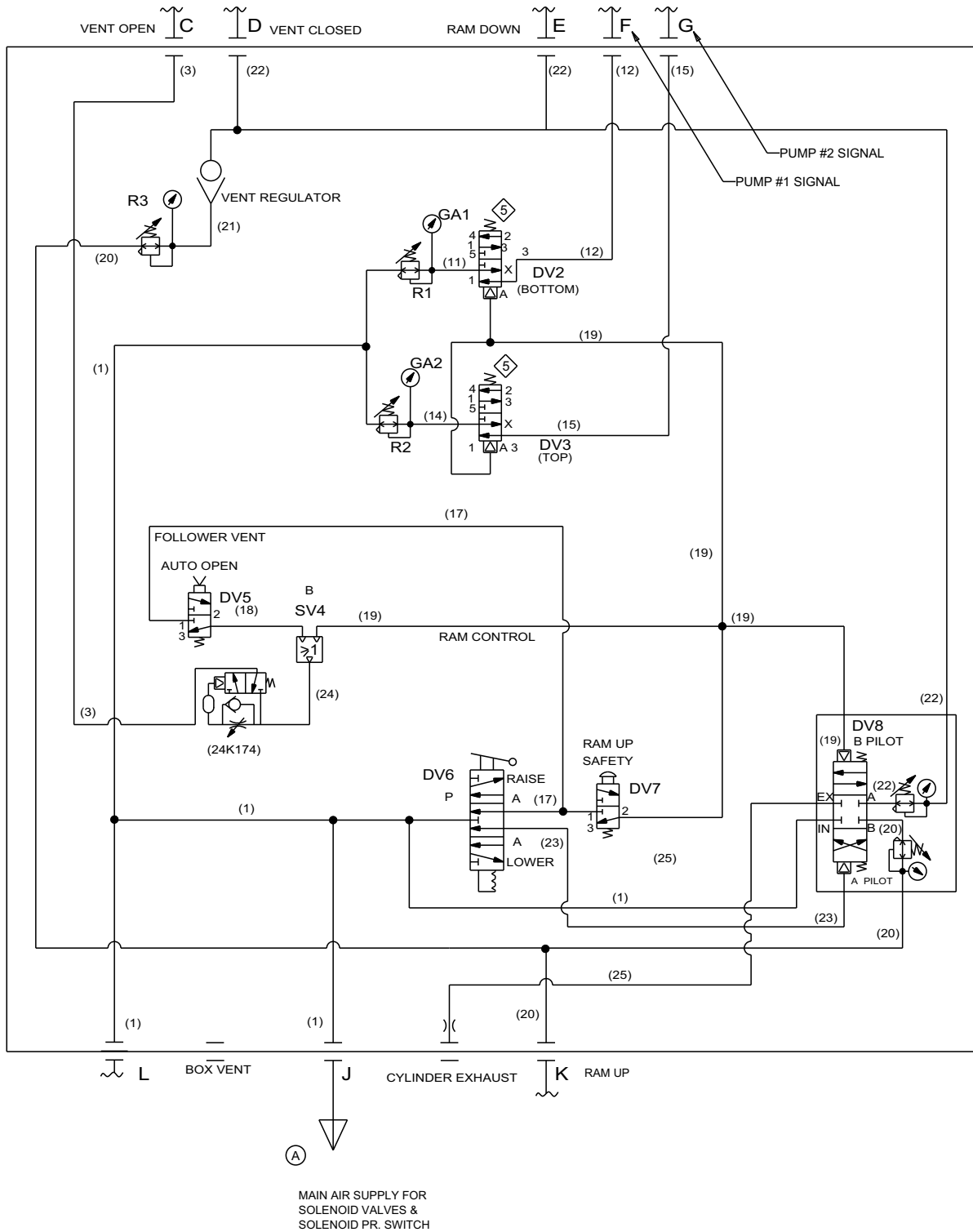

FIG. 41



# Technical Specifications

## Models 248306, 248307, 249339, 249340, 253676, 253677

<b>Uni-Drum Supply System</b>		
	<b>US</b>	<b>Metric</b>
<b>Supply Units (LH and RH)</b>		
Compressed air requirement	80 psi (maximum) (5.5 bar, 0.55 MPa), 450 cfm	
Main air inlet size	1 in. npt(f)	
Overall weight (approximate)	3950 lb	1792 kg
<b>Pumps (1/unit) 24Y228, 24Y227</b>		
Ratio	47:1 fluid to air power ratio	
Maximum fluid working pressure	4500 psi (310 bar, 31.0 MPa)	
Maximum air input pressure	95 psi (7 bar, 0.7 MPa)	
Pump cycles	8.7 per 1 gal.	8.7 per 3.8 liters
Recommended pump speed for continuous operation	60 cycles per min	
Maximum flow rate at 60 cycles/min	6.9 gpm	26.1 liters/min
Air motor piston effective area	132.7 in. <sup>2</sup>	856 cm <sup>2</sup>
Stroke length	4.8 in.	122 mm
Air motor cylinder inside diameter	13 in.	330 mm
Displacement pump effective area	2.79 in. <sup>2</sup>	18 cm <sup>2</sup>
Maximum pump operating temperature	150° F	65.5° C
Air inlet size	1 in. npt(f)	
Fluid inlet size	2 in. npt(f)	
Fluid outlet size	1-1/2 in. npt(m)	
Wetted components	304, 329, and 17-4 PH Grades of stainless steel; silicone nitride; acetal; Ultra-high molecular weight polyethylene, and leather	
Weight per pump	Approx. 234 lbs.	Approx. 106 kg
<b>Voltage</b>		
248306, 248307, 253676, 253677	120V	
249339, 249340	24V	
<b>Supply System Overall Dimensions</b>		
Width	69 in.	1753 mm
Depth	51 in.	1295 mm
Height (lowered)	85.2 in.	2164 mm
Height (raised)	141 in.	3581 mm

## Models 249152, 249153, 249341, 249342, 234972, 234973, 258956, 258957, 24U642, 24U643, 25N914, 25N915

Uni-Drum Supply System		
	US	Metric
<b>Supply Units (LH and RH)</b>		
Compressed air requirement	80 psi (maximum) (5.5 bar, 0.55 MPa), 450 cfm	
Main air inlet size	1 in. npt(f)	
Overall weight (approximate)	3950 lb	1792 kg
<b>Pumps (1/unit) 24Y192, 24Y206</b>		
Ratio	35:1 fluid to air power ratio	
Maximum fluid working pressure	3400 psi (231 bar, 23.1 MPa)	
Maximum air input pressure	95 psi (7 bar, 0.7 MPa)	
Pump cycles	6.5 per 1 gal.	6.5 per 3.8 liters
Recommended pump speed for continuous operation	60 cycles per min	
Maximum flow rate at 60 cycles/min	9.2 gpm	34.6 liters/min
Air motor piston effective area	132.7 in. <sup>2</sup>	856 cm <sup>2</sup>
Stroke length	4.8 in.	122 mm
Air motor cylinder inside diameter	13in.	330 mm
Displacement pump effective area	3.72 in. <sup>2</sup>	24 cm <sup>2</sup>
Maximum pump operating temperature	150° F	65.5° C
Air inlet size	1 in. npt(f)	
Fluid inlet size	2 in. npt(f)	
Fluid outlet size	1-1/2 in. npt(m)	
Wetted components	<b>All Models:</b> 304, 329, and 17-4 PH Grades of stainless steel; silicone nitride; acetal; Ultra-high molecular weight polyethylene, and leather <b>24U642 and 24U643 only:</b> carbon steel	
Weight per pump	Approx. 234 lbs.	Approx. 106 kg
<b>Voltage</b>		
249152, 249153, 234972, 234973, 25N914, 25N915	120V	
258956, 258957, 249341, 249342, 24 u642, 24 u643	24V	
<b>Supply System Overall Dimensions</b>		
Width	69 in.	1753 mm
Depth	51 in.	1295 mm
Height (lowered)	85.2 in.	2164 mm
Height (raised)	141 in.	3581 mm

## Models 232729, 232730, 255665, 255666

<b>Uni-Drum Supply System</b>		
	<b>US</b>	<b>Metric</b>
<b>Supply Units (LH and RH)</b>		
Compressed air requirement	80 psi (maximum) (5.5 bar, 0.55 MPa), 450 cfm	
Main air inlet size	1 in. npt(f)	
Overall weight (approximate)	3950 lb	1792 kg
<b>Pumps (1/unit) 24Y211, 24Y212</b>		
Ratio	47:1 fluid to air power ratio	
Maximum fluid working pressure	4500 psi (310 bar, 31.0 MPa)	
Maximum air input pressure	95 psi (7 bar, 0.7 MPa)	
Pump cycles	8.7 per 1 gal.	8.7 per 3.8 liters
Recommended pump speed for continuous operation	60 cycles per min	
Maximum flow rate at 60 cycles/min	6.9 gpm	26.1 liters/min
Air motor piston effective area	132.7 in. <sup>2</sup>	856 cm <sup>2</sup>
Stroke length	4.8 in.	122 mm
Displacement pump effective area	2.79 in. <sup>2</sup>	18 cm <sup>2</sup>
Maximum pump operating temperature	150° F	65.5° C
Air inlet size	1 in. npt(f)	
Fluid inlet size	2 in. npt(f)	
Fluid outlet size	1-1/2 in. npt(m)	
Wetted components	Carbon steel, chrome, zinc, and electroless nickel plating; 304, 440 and 17-4 PH Grades of stainless steel; tungsten carbide; ductile iron; acetal; PTFE, leather	
Weight per pump	Approx. 234 lbs.	Approx. 106 kg
<b>Voltage</b>		
232729, 232730	120V	
255665, 255666	24V	
<b>Supply System Overall Dimensions</b>		
Width	69 in.	1753 mm
Depth	51 in.	1295 mm
Height (lowered)	85.2 in.	2164 mm
Height (raised)	141 in.	3581 mm



## Models 232839, 232840, 246921, 246922

Uni-Drum Supply System		
	US	Metric
<b>Supply Units (LH and RH)</b>		
Compressed air requirement	80 psi (maximum) (5.5 bar, 0.55 MPa), 450 cfm	
Main air inlet size	1 in. npt(f)	
Overall weight (approximate)	3950 lb	1792 kg
<b>Pumps (1/unit) 24Y221, 24Y222, 24Y225, 24Y226</b>		
Ratio	47:1 fluid to air power ratio	
Maximum fluid working pressure	4500 psi (310 bar, 31.0 MPa)	
Maximum air input pressure	95 psi (7 bar, 0.7 MPa)	
Pump cycles	8.7 per 1 gal.	8.7 per 3.8 liters
Recommended pump speed for continuous operation	60 cycles per min	
Maximum flow rate at 60 cycles/min	6.9 gpm	26.1 liters/min
Air motor piston effective area	132.7 in. <sup>2</sup>	856 cm <sup>2</sup>
Stroke length	4.8 in.	122 mm
Air motor cylinder inside diameter	13 in.	330 mm
Displacement pump effective area	2.79 in. <sup>2</sup>	18 cm <sup>2</sup>
Maximum pump operating temperature	150° F	65.5° C
Air inlet size	1 in. npt(f)	
Fluid inlet size	2 in. npt(f)	
Fluid outlet size	1-1/2 in. npt(m)	
Voltage	120V	
Wetted components	304, 329 and 17-4 PH Grades of stainless steel; tungsten carbide; acetal; PTFE, Ultra-high molecular weight polyethylene, leather	
Weight per pump	Approx. 234 lbs.	Approx. 106 kg
<b>Supply System Overall Dimensions</b>		
Width	69 in.	1753 mm
Depth	51 in.	1295 mm
Height (lowered)	85.2 in.	2164 mm
Height (raised)	141 in.	3581 mm

## California Proposition 65

### CALIFORNIA RESIDENTS

 **WARNING:** Cancer and reproductive harm – [www.P65warnings.ca.gov](http://www.P65warnings.ca.gov).

# Graco Standard Warranty

Graco warrants all equipment referenced in this document which is manufactured by Graco and bearing its name to be free from defects in material and workmanship on the date of sale to the original purchaser for use. With the exception of any special, extended, or limited warranty published by Graco, Graco will, for a period of twelve months from the date of sale, repair or replace any part of the equipment determined by Graco to be defective. This warranty applies only when the equipment is installed, operated and maintained in accordance with Graco's written recommendations.

This warranty does not cover, and Graco shall not be liable for general wear and tear, or any malfunction, damage or wear caused by faulty installation, misapplication, abrasion, corrosion, inadequate or improper maintenance, negligence, accident, tampering, or substitution of non-Graco component parts. Nor shall Graco be liable for malfunction, damage or wear caused by the incompatibility of Graco equipment with structures, accessories, equipment or materials not supplied by Graco, or the improper design, manufacture, installation, operation or maintenance of structures, accessories, equipment or materials not supplied by Graco.

This warranty is conditioned upon the prepaid return of the equipment claimed to be defective to an authorized Graco distributor for verification of the claimed defect. If the claimed defect is verified, Graco will repair or replace free of charge any defective parts. The equipment will be returned to the original purchaser transportation prepaid. If inspection of the equipment does not disclose any defect in material or workmanship, repairs will be made at a reasonable charge, which charges may include the costs of parts, labor, and transportation.

**THIS WARRANTY IS EXCLUSIVE, AND IS IN LIEU OF ANY OTHER WARRANTIES, EXPRESS OR IMPLIED, INCLUDING BUT NOT LIMITED TO WARRANTY OF MERCHANTABILITY OR WARRANTY OF FITNESS FOR A PARTICULAR PURPOSE.**

Graco's sole obligation and buyer's sole remedy for any breach of warranty shall be as set forth above. The buyer agrees that no other remedy (including, but not limited to, incidental or consequential damages for lost profits, lost sales, injury to person or property, or any other incidental or consequential loss) shall be available. Any action for breach of warranty must be brought within two (2) years of the date of sale.

**GRACO MAKES NO WARRANTY, AND DISCLAIMS ALL IMPLIED WARRANTIES OF MERCHANTABILITY AND FITNESS FOR A PARTICULAR PURPOSE, IN CONNECTION WITH ACCESSORIES, EQUIPMENT, MATERIALS OR COMPONENTS SOLD BUT NOT MANUFACTURED BY GRACO.** These items sold, but not manufactured by Graco (such as electric motors, switches, hose, etc.), are subject to the warranty, if any, of their manufacturer. Graco will provide purchaser with reasonable assistance in making any claim for breach of these warranties.

In no event will Graco be liable for indirect, incidental, special or consequential damages resulting from Graco supplying equipment hereunder, or the furnishing, performance, or use of any products or other goods sold hereto, whether due to a breach of contract, breach of warranty, the negligence of Graco, or otherwise.

## **FOR GRACO CANADA CUSTOMERS**

The Parties acknowledge that they have required that the present document, as well as all documents, notices and legal proceedings entered into, given or instituted pursuant hereto or relating directly or indirectly hereto, be drawn up in English. Les parties reconnaissent avoir convenu que la rédaction du présente document sera en Anglais, ainsi que tous documents, avis et procédures judiciaires exécutés, donnés ou intentés, à la suite de ou en rapport, directement ou indirectement, avec les procédures concernées.

# Graco Information

## Sealant and Adhesive Dispensing Equipment

For the latest information about Graco products, visit [www.graco.com](http://www.graco.com).

For patent information, see [www.graco.com/patents](http://www.graco.com/patents).

**TO PLACE AN ORDER**, contact your Graco distributor, go to [www.graco.com](http://www.graco.com), or call to identify the nearest distributor.

**If calling from the USA:** 1-800-746-1334

**If calling from outside the USA:** 0-1-330-966-3000

*All written and visual data contained in this document reflects the latest product information available at the time of publication. Graco reserves the right to make changes at any time without notice.*

Original instructions. This manual contains English. MM 309028

**Graco Headquarters:** Minneapolis

**International Offices:** Belgium, China, Japan, Korea

**GRACO INC. AND SUBSIDIARIES • P.O. BOX 1441 • MINNEAPOLIS MN 55440-1441 • USA**  
**Copyright 2020, Graco Inc. All Graco manufacturing locations are registered to ISO 9001.**

[www.graco.com](http://www.graco.com)  
Revision ZAU, August 2022