

Husky™ 515/Husky™ 716 Drum Pump Kits and Packages

309116G



Important Safety Instructions

Read all warnings and instructions in this manual.
Save these instructions.

233045

Accessory kit for pump Model No. 241565

233046

Accessory kit for pump Model Nos. 241564,
233305, 243306, 243307

233047

Accessory kit for pump Model No. 241564

233048

Accessory kit for pump Model No. 24B674

233051

Drum pump package including Kit No. 233045
and pump Model No. 241565

233052*

Drum pump package including Kit No. 233047
and pump Model No. 241564

233053*

Drum pump package including Kit No. 233046
and pump Model No. 241564

233054*

Drum pump package including Kit No. 233046
and pump Model No. 243305

233055*

Drum pump package including Kit No. 233046 and pump Model No. 243306

233056*

Drum pump package including Kit No. 233046 and pump Model No. 243307

233057*

Drum pump package including Kit No. 233048 and pump Model No. 24B674

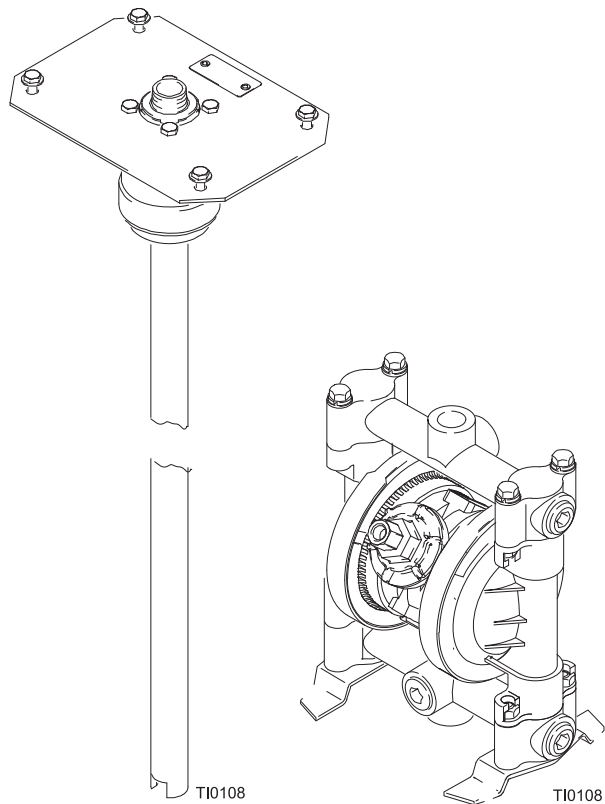

*  **Ex II 2 GD**
Ex h IIC 66°C...135°C Gb
Ex h IIC T135°C Db

ATEX T-code rating is dependent on the temperature of the fluid being pumped. Fluid temperature is limited by the materials of the pump interior wetted parts. See Technical Data for the maximum fluid operating temperature for your specific pump model.

Table of Contents

Warnings	2
Installation	5
Dimensional Drawing	6
Service	7
Parts	7
Kits and Packages	7
Parts List and Accessory Kit Matrix	8
Parts Drawing	9
Pump Package Matrix	10
Technical Data	11
Graco Standard Husky Pump Warranty	12
Graco Information	12

Symbols

Warning Symbol



This symbol alerts you to the possibility of serious injury or death if you do not follow the instructions.

Caution Symbol



This symbol alerts you to the possibility of damage to or destruction of equipment if you do not follow the instructions.

! WARNING

 INSTRUCTIONS	<p>EQUIPMENT MISUSE HAZARD</p> <p>Equipment misuse can cause the equipment to rupture or malfunction and result in serious injury.</p> <ul style="list-style-type: none"> • This equipment is for professional use only. • Read all instruction manuals, tags, and labels before operating the equipment. • Use the equipment only for its intended purpose. If you are not sure, call your Graco distributor. • Do not alter or modify this equipment. Use only genuine Graco parts and accessories. • Check equipment daily. Repair or replace worn or damaged parts immediately. • Do not exceed the maximum working pressure of the lowest rated component in your system. • Use fluids and solvents that are compatible with the equipment wetted parts. Refer to the Technical Data section of all equipment manuals. Read the fluid and solvent manufacturer's warnings. • Always wear protective eyewear, gloves, clothing, and respirator as recommended by the fluid and solvent manufacturer. • Wear hearing protection when operating this equipment. • Comply with all applicable local, state, and national fire, electrical, and safety regulations. • Route hoses away from traffic areas, sharp edges, moving parts, and hot surfaces. Do not expose hoses to temperatures above 180° F (82° C) or below -40° F (-40° C). • Do not lift pressurized equipment. • Comply with all applicable local, state, and national fire, electrical, and safety regulations. • Do not use 1.1.1-trichloroethane, Methylene chloride, other halogenated hydrocarbon solvents or fluids containing such solvents in pressurized aluminum equipment. Such use could result in a chemical reaction, with the possibility of explosion.
--	---

WARNING



TOXIC FLUID HAZARD

Hazardous fluids or toxic fumes can cause serious injury or death if splashed in the eyes or on the skin, swallowed, or inhaled. When flushing the air motor or pump, keep your face away from the exhaust port.

- Know the specific hazards of the fluid you are using.
- Do not lift a pump under pressure. If dropped, the fluid section may rupture. Always follow the **Pressure Relief Procedure** in the pump manual before lifting the pump.
- Store hazardous fluid in an approved container. Dispose of hazardous fluid according to all local, state, and national guidelines.
- Always wear protective eyewear, gloves, clothing, and respirator as recommended by the fluid and solvent manufacturer.
- Pipe and dispose of exhaust air safely, away from people, animals, and food handling areas. If the diaphragm fails, the fluid is exhausted along with the air. Read **Exhaust Air Ventilation** in instruction manual 308981.
- **Never** use an acetal pump to pump acids. Take precautions to avoid acid or acid fumes from contacting the pump housing exterior. Stainless steel parts will be damaged by exposure to acid spills and fumes.



FIRE AND EXPLOSION HAZARD

Improper grounding, poor ventilation, open flames, or sparks can cause a hazardous condition and result in a fire or explosion and serious injury.

- Ground all equipment and the equipment being dispensed to. Refer to **Grounding** in instruction manual 308981.
- **Never** use a polypropylene pump with non-conductive flammable fluids as specified by your local fire protection code. Refer to **Grounding** in instruction manual 308981 for more information. Consult your fluid supplier to determine the conductivity or resistivity of your fluid.
- If you are dispensing non-conductive flammable fluids, you must use the unit with the acetal pump, which is conductive.
- If there is any static sparking or if you feel an electric shock while using this equipment, **stop pumping immediately**. Do not use the equipment until you identify and correct the problem.
- Provide fresh air ventilation to avoid the buildup of flammable fumes from solvents or the fluid being dispensed.
- Pipe and dispose of exhaust air safely, away from all sources of ignition. If the diaphragm fails, the fluid is exhausted along with the air. Read **Air Exhaust Ventilation** in instruction manual 308981.
- Keep the work area free of debris, including solvent, rags, and gasoline.
- Electrically disconnect all equipment in the work area.
- Extinguish all open flames and pilot lights in the dispensing area.
- Do not smoke in the work area.
- Do not turn on or off any light switch in the work area while operating or if fumes are present.
- Do not operate a gasoline engine in the work area.

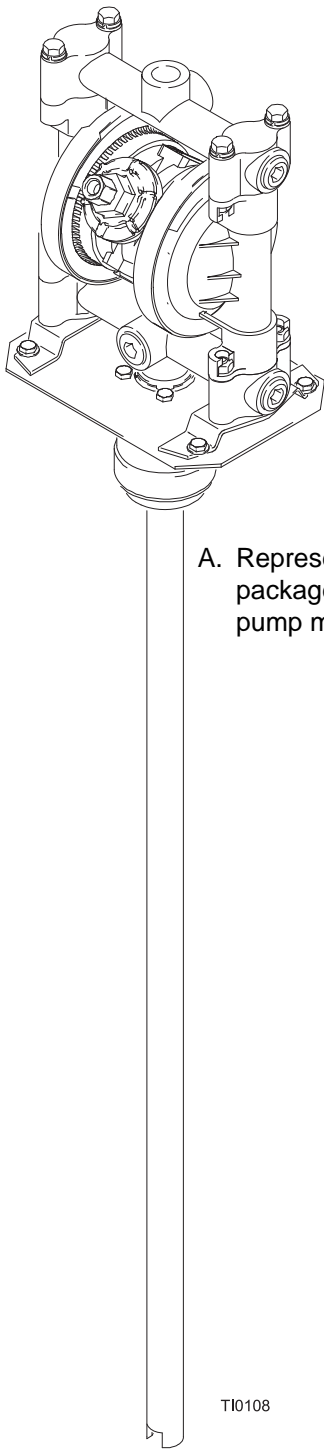

A. Representative package with pump mounted

TI0108

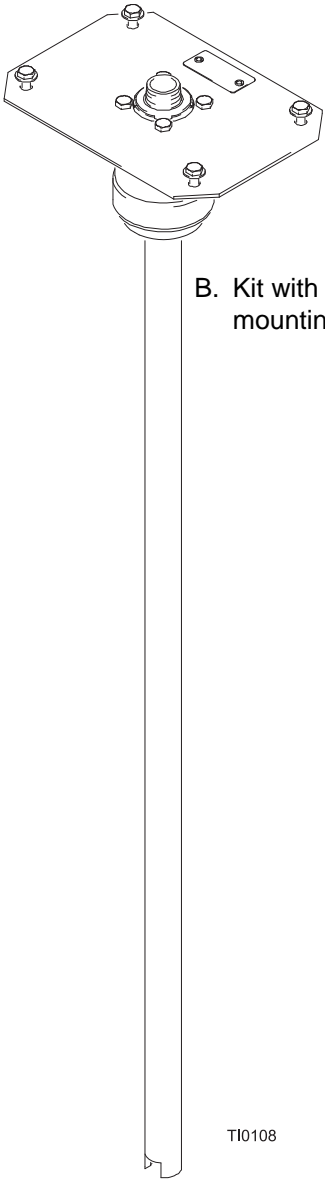

B. Kit with standard mounting plate

TI0108

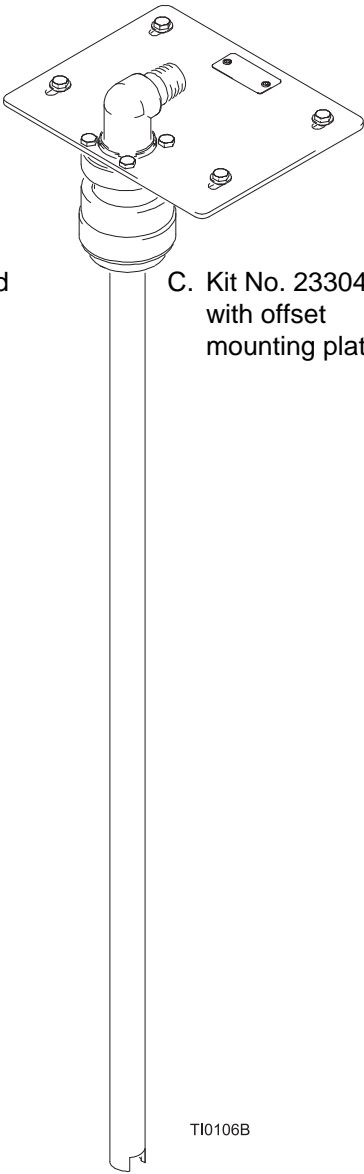

C. Kit No. 233048 with offset mounting plate

TI0106B

Installation

Grounding

WARNING



FIRE AND EXPLOSION HAZARD

This unit must be grounded. Before you operate it, ground the system as explained in this section. Also, read **Fire and Explosion Hazard** on page 3. For further grounding information, read the **Grounding** section in instruction manual 308981.

Proper grounding is an essential part of maintaining a safe system.

To reduce the risk of static sparking, ground the pump and all other equipment used or located in the pumping area. Check your local electrical code for detailed grounding instructions for your area and type of equipment.

Installation

CAUTION

Prolonged exposure to UV radiation will degrade natural polypropylene components of the pumps. To prevent potential injury or equipment damage, do not expose pump or the plastic components to direct sunlight for prolonged periods.

NOTE: Numbers in parentheses refer to parts as defined on the parts list on page 8 and the parts drawing on page 9.

1. Remove the knurled bung adaptor (5) and the bung gasket (2) from the bung adaptor base assembly and install it onto the 55-gallon drum.
2. Tighten 1/4 turn past hand-tight to ensure that the bung gasket (2) engages the drum cover.
3. If an air-tight seal is required, place the white foam gasket (9) in the recess on top of the bung adaptor (8).
4. Loosely attach the pump to the mounting plate with the 4 washers (4) and 4 screws (1) provided.
5. Apply sealant to the threads of the suction tube (101).
6. Insert the threaded end of the suction tube (101) through the bottom of the bung adaptor base assembly and tighten it into the inlet manifold of the pump.
7. Tighten the four screws (1) that attach the pump to the mounting plate (7).
8. Insert the assembly into the drum through the bung adaptor (5) installed on the drum.
9. Tighten the retainer (6) 1/4 turn past hand-tight to ensure the PTFE o-ring (3) seals against the bung adaptor base assembly.
10. Ground the pump and the system. Refer to instruction manual 308981.
11. Follow the installation procedure in instruction manual 308981 to complete the installation of the air and fluid lines to and from the pump.
12. Open the second hole in the drum cover to introduce make-up air or inert gas. The bung adaptor and bung adaptor base seal against the drum. Failure to provide make-up air or inert gas could cause the drum to collapse. If necessary, take applicable steps to ensure the make-up air is dry and that dangerous gases do not escape from the drum.
13. To operate the pump, follow the procedures in instruction manual 308981.

WARNING

TIPPING HAZARD

When mounting the stainless steel pump (24B674), ensure that the offset mounting plate (7) is positioned so that the pump is mounted over the drum to prevent tipping when the fluid level in the drum is low.

These units should be used only on drums positioned on a flat, level surface. Uneven or slanted surfaces could cause the drum to tip over.

Do not relocate a drum with the unit mounted in the bung hole. When the unit is mounted, the center of gravity is too high for stability when moving the drum.

CAUTION

The bung adaptor (8) has 2.5 in. of adjustment to accommodate slight variances in drum size. To ensure that the bung adaptor does not come out of the retainer, do not allow the bottom of the larger diameter of the bung adaptor to extend more than 2.5 in. from the retainer (6).

Dimensional Drawing

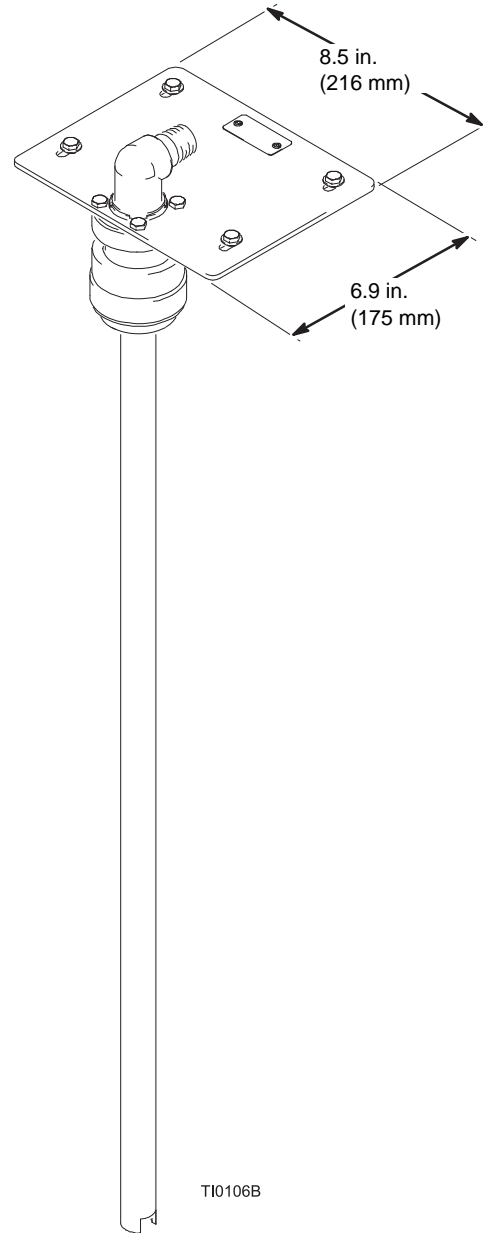
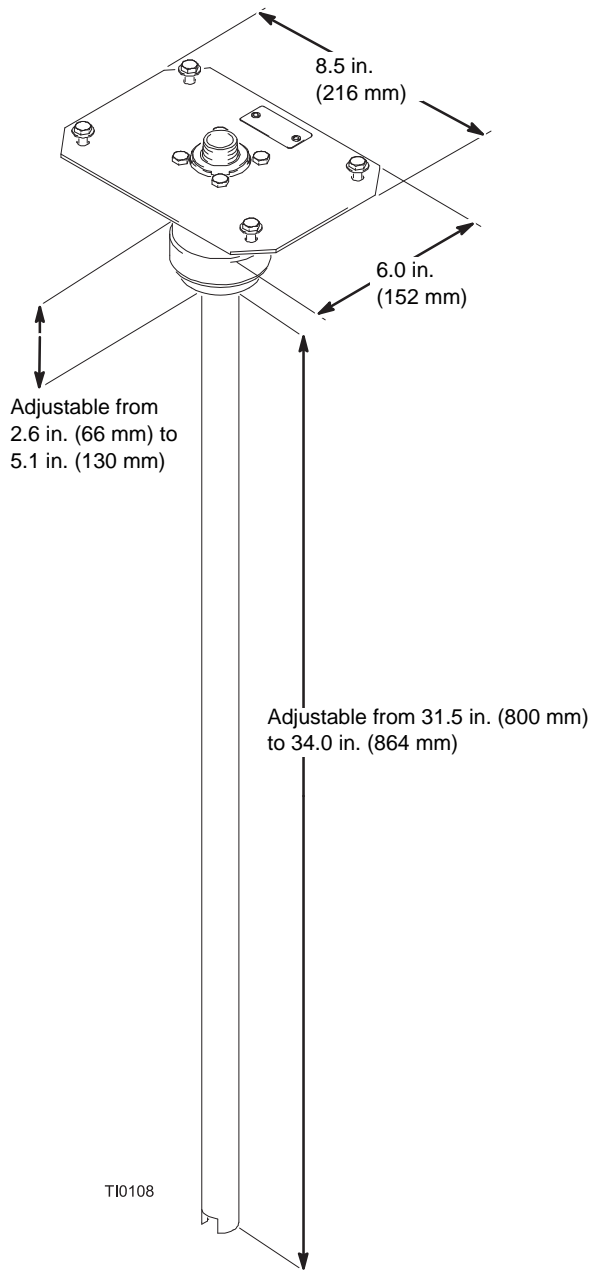

Service

For service instructions specific to the pump, see instruction manual 308981.

Parts

Kits

Pump Accessory Kit 233045

Includes polypropylene bung base 233073 and polypropylene suction tube 196096.

Pump Accessory Kit 233046

Includes acetal bung base 233074 and aluminum suction tube 196095.

Pump Accessory Kit 233047

Includes acetal bung base 233074 and stainless steel suction tube 196094.

Pump Accessory Kit 233048

Includes stainless steel bung base 233076 and stainless steel suction tube 196094.

Pumps

Part No.	Description	Qty.
241564	PUMP, Husky 515 Fluid section: acetal (groundable) Guides: acetal Balls: PTFE Diaphragms: PTFE	1
241565	PUMP, Husky 515 Fluid section: polypropylene Guides: polypropylene Balls: PTFE Diaphragms: PTFE	1
243305	PUMP, Husky 716 Fluid section: aluminum Guides: acetal Balls: Santoprene® Diaphragms: Santoprene®	1
243306	PUMP, Husky 716 Fluid section: aluminum Guides: acetal Balls: buna-N Diaphragms: buna-N	1
243307	PUMP, Husky 716 Fluid section: aluminum Guides: acetal Balls: PTFE Diaphragms: PTFE	1
24B674	PUMP, Husky 716 Fluid section: stainless steel Guides: stainless steel Balls: PTFE Diaphragms: PTFE	1

Packages

Drum Pump Package 233051

Includes pump 241565 and Kit No. 233045

Drum Pump Package 233052

Includes pump 241564 and Kit No. 233047

Drum Pump Package 233053

Includes pump 241564 and Kit No. 233046

Drum Pump Package 233054

Includes pump 243305 and Kit No. 233046

Drum Pump Package 233055

Includes pump 243306 and Kit No. 233046

Drum Pump Package 233056

Includes pump 243307 and Kit No. 233046

Drum Pump Package 233057

Includes pump 24B674 and Kit No. 233048

Parts List and Accessory Kit Matrix

Ref. No.	Part No.	Description	Kits			
			233045	233046	233047	233048
1	102023	SCREW, cap	8	8	8	8
2	106537	GASKET, bung	1	1	1	1
3	112553	PACKING, O-ring	1	1	1	1
4	115814	WASHER, flat, SST	4	4	4	8
5	178575	ADAPTOR, bung	1	1	1	1
6	178576	RETAINER, O-ring	1	1	1	1
7	196092	PLATE, mounting, offset				1
	196093	PLATE, mounting	1	1	1	
8	196097	ADAPTOR, bung, polypropylene	1			
	196098	ADAPTOR, bung, acetal		1	1	
	196099	ADAPTOR, bung, stainless steel				1
9	196103	GASKET	1	1	1	1
10	111183	RIVET, pop	2	2	2	2
11	290045	PLATE, designation	1	1	1	1
12	115813	FITTING, street elbow				1
13	101324	NUT, hex, jam				4
14	102025	NUT, full, hex, regular				4
101	196094	TUBE, suction, stainless steel			1	1
	196095	TUBE, suction, aluminum		1		
	196096	TUBE, suction, polypropylene	1			

Parts Drawing

Offset mounting plate and street elbow for use with stainless steel pump, model 24B674.

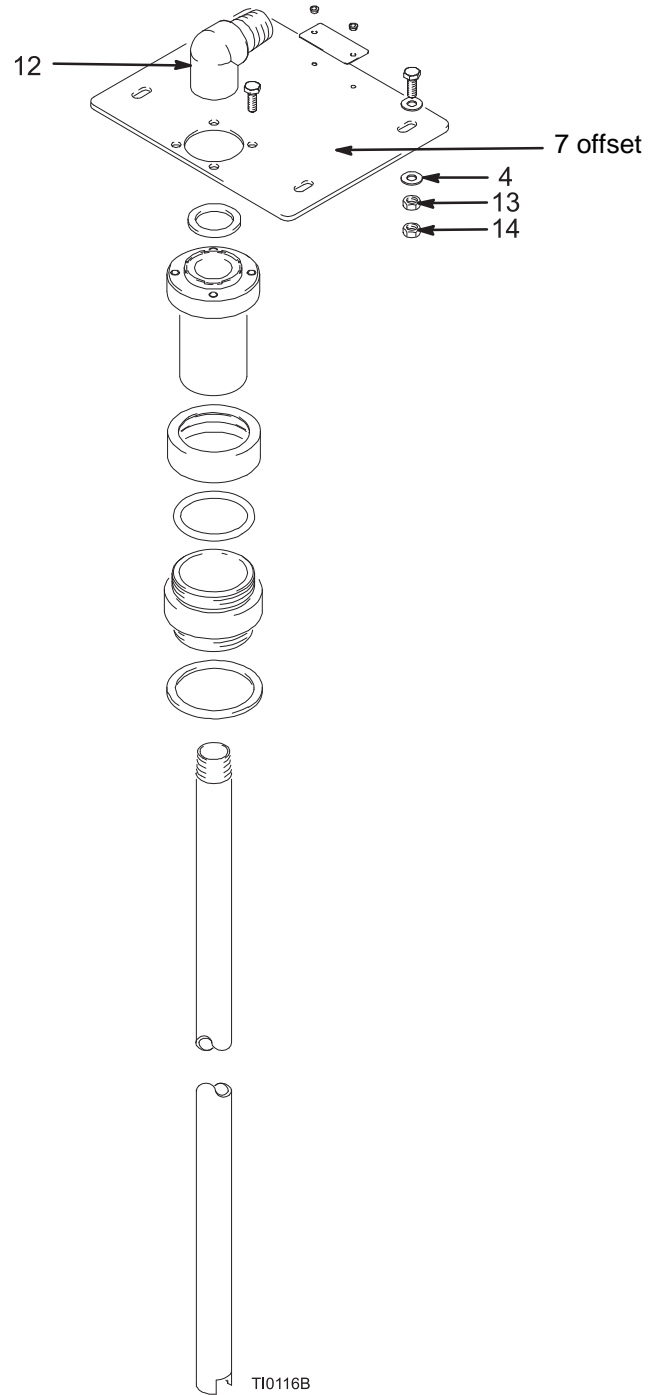
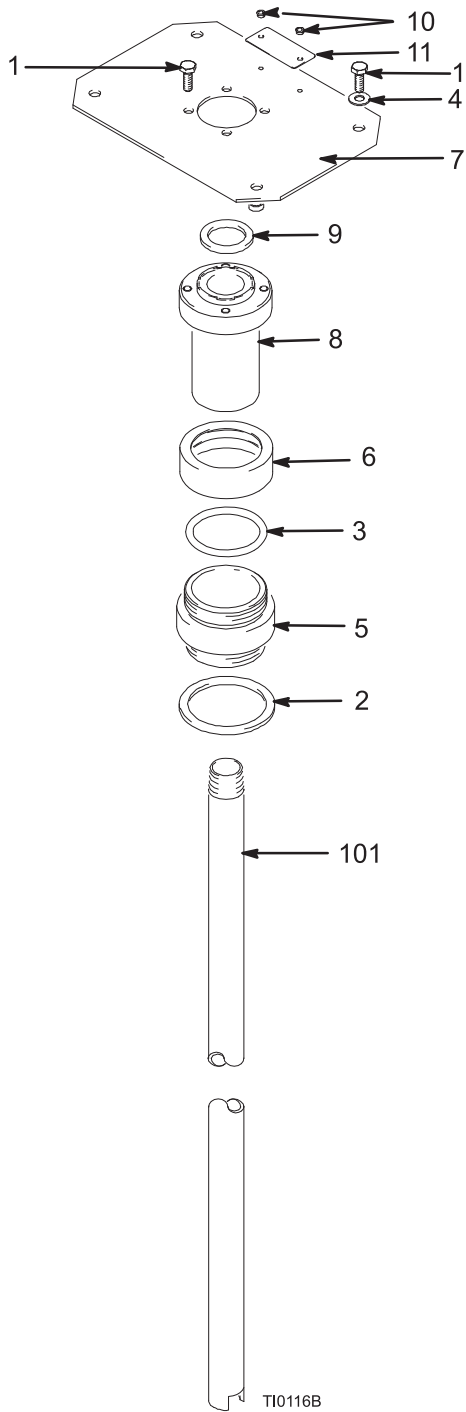

Pump Package Matrix

Package Part No.	Description	Pump						Bung Base				Tube	
		241565 PP-PP-TE-TE	241564 AC-AC-TE-TE	243305 AL-AC-SA-SA	243306 AL-AC-BU-BU	243307 AL-AC-TE-TE	24B674 SS-SS-TE-TE	233045 PP/PP	233046 AC/AL	233047 AC/SS	233048 SS/SS	196094 SS	196095 AL
233051	Polypropylene/PTFE with polypropylene tube	✓					✓						✓
233052	Acetal/PTFE with stainless steel tube		✓						✓		✓		
233053	Acetal/PTFE with aluminum tube		✓					✓				✓	
233054	Aluminum/Santoprene with aluminum tube			✓				✓				✓	
233055	Aluminum/buna-N				✓			✓				✓	
233056	Aluminum/PTFE with aluminum tube					✓		✓				✓	
233057	Stainless steel/Stainless steel with stainless steel tube						✓			✓	✓		

See the **Parts Drawing** on page 9.

Technical Data

Husky 515/716

Maximum fluid working pressure	100 psi (0.7 MPa, 7 bar)
Air pressure operating range	30 –100 psi (0.2–0.7 MPa, 2.1–7 bar)
Operating Temperature Range*	
Minimum (all pumps)	40°F (4°C)
Maximum	
Acetal:	180°F (82°C)
Polypropylene:	150°F (66°C)
Aluminum, stainless steel, PVDF:	225°F (107°C)
Weight	
233045	4.0 lb (1.8 kg)
233046	4.5 lb (2.0 kg)
233047	6.5 lb (2.9 kg)
233048	9.5 lb (4.3 kg)
Wetted parts	
233045	polypropylene
233046	aluminum
233047	stainless steel
233048	stainless steel
Non-wetted parts (materials vary depending on kit)	
epoxy-coated steel, stainless steel, PTFE, nickel-plated steel, polyethylene, polypropylene, aluminum, zinc-plated steel	

*These temperatures are based on mechanical stress only and may be altered significantly by pumping certain chemicals. Consult engineering guides for chemical compatibilities and temperature limits, or contact your Graco distributor.

Santoprene® is a registered trademark of the Monsanto Company.

For additional technical data specific to the pump, refer to instruction manual 308981.

Graco Standard Husky Pump Warranty

Graco warrants all equipment referenced in this document which is manufactured by Graco and bearing its name to be free from defects in material and workmanship on the date of sale by an authorized Graco distributor to the original purchaser for use. With the exception of any special, extended, or limited warranty published by Graco, Graco will, for a period of twelve months from the date of sale, repair or replace any part of the equipment determined by Graco to be defective. This warranty applies only when the equipment is installed, operated and maintained in accordance with Graco's written recommendations.

This warranty does not cover, and Graco shall not be liable for general wear and tear, or any malfunction, damage or wear caused by faulty installation, misapplication, abrasion, corrosion, inadequate or improper maintenance, negligence, accident, tampering, or substitution of non-Graco component parts. Nor shall Graco be liable for malfunction, damage or wear caused by the incompatibility of Graco equipment with structures, accessories, equipment or materials not supplied by Graco, or the improper design, manufacture, installation, operation or maintenance of structures, accessories, equipment or materials not supplied by Graco.

This warranty is conditioned upon the prepaid return of the equipment claimed to be defective to an authorized Graco distributor for verification of the claimed defect. If the claimed defect is verified, Graco will repair or replace free of charge any defective parts. The equipment will be returned to the original purchaser transportation prepaid. If inspection of the equipment does not disclose any defect in material or workmanship, repairs will be made at a reasonable charge, which charges may include the costs of parts, labor, and transportation.

THIS WARRANTY IS EXCLUSIVE, AND IS IN LIEU OF ANY OTHER WARRANTIES, EXPRESS OR IMPLIED, INCLUDING BUT NOT LIMITED TO WARRANTY OF MERCHANTABILITY OR WARRANTY OF FITNESS FOR A PARTICULAR PURPOSE.

Graco's sole obligation and buyer's sole remedy for any breach of warranty shall be as set forth above. The buyer agrees that no other remedy (including, but not limited to, incidental or consequential damages for lost profits, lost sales, injury to person or property, or any other incidental or consequential loss) shall be available. Any action for breach of warranty must be brought within two (2) years of the date of sale.

GRACO MAKES NO WARRANTY, AND DISCLAIMS ALL IMPLIED WARRANTIES OF MERCHANTABILITY AND FITNESS FOR A PARTICULAR PURPOSE IN CONNECTION WITH ACCESSORIES, EQUIPMENT, MATERIALS OR COMPONENTS SOLD BUT NOT MANUFACTURED BY GRACO. These items sold, but not manufactured by Graco (such as electric motors, switches, hose, etc.), are subject to the warranty, if any, of their manufacturer. Graco will provide purchaser with reasonable assistance in making any claim for breach of these warranties.

In no event will Graco be liable for indirect, incidental, special or consequential damages resulting from Graco supplying equipment hereunder, or the furnishing, performance, or use of any products or other goods sold hereto, whether due to a breach of contract, breach of warranty, the negligence of Graco, or otherwise.

FOR GRACO CANADA CUSTOMERS

The parties acknowledge that they have required that the present document, as well as all documents, notices and legal proceedings entered into, given or instituted pursuant hereto or relating directly or indirectly hereto, be drawn up in English. Les parties reconnaissent avoir convenu que la rédaction du présente document sera en Anglais, ainsi que tous documents, avis et procédures judiciaires exécutés, donnés ou intentés à la suite de ou en rapport, directement ou indirectement, avec les procédures concernées.

Graco Information

For the latest information about Graco products, visit www.graco.com.

For patent information, see www.graco.com/patents.

TO PLACE AN ORDER, contact your Graco distributor, or call one of the following numbers to identify the distributor closest to you:

1-800-328-0211 Toll Free

612-623-6921

612-378-3505 Fax

All written and visual data contained in this document reflects the latest product information available at the time of publication.

Graco reserves the right to make changes at any time without notice.

Original instructions. This manual contains English. MM 309116

Graco Headquarters: Minneapolis

International Offices: Belgium, China, Japan, Korea

GRACO INC. P.O. BOX 1441 MINNEAPOLIS, MN 55440-1441

Copyright 2000, Graco Inc. All Graco manufacturing locations are registered to ISO 9001

www.graco.com

Revision G, August 2019