

Instructions–Parts List



STAINLESS STEEL, WATERBASE COMPATIBLE

Back Pressure Valve

310537C

EN

Used with abrasive fluids in circulating systems to provide regulated back pressure to the spray gun(s) and to maintain proper circulating pressure throughout the system. For professional use only.



Important Safety Instructions

Read all warnings and instructions in this manual.
Save these instructions.

300 psi (2.1 MPa, 21 bar) Maximum Inlet Pressure

200 psi (1.4 MPa, 14 bar) Maximum Regulated Pressure

Model 916154

Stainless Steel Back Pressure Valve,
with carbide wear parts, for use with abrasive fluids

Table of Contents

Warnings	2
Installation	3
Operation	3
Service	4
Parts	5
Dimensions	6
Technical Data	7
Graco Standard Warranty	8
Graco Information	8

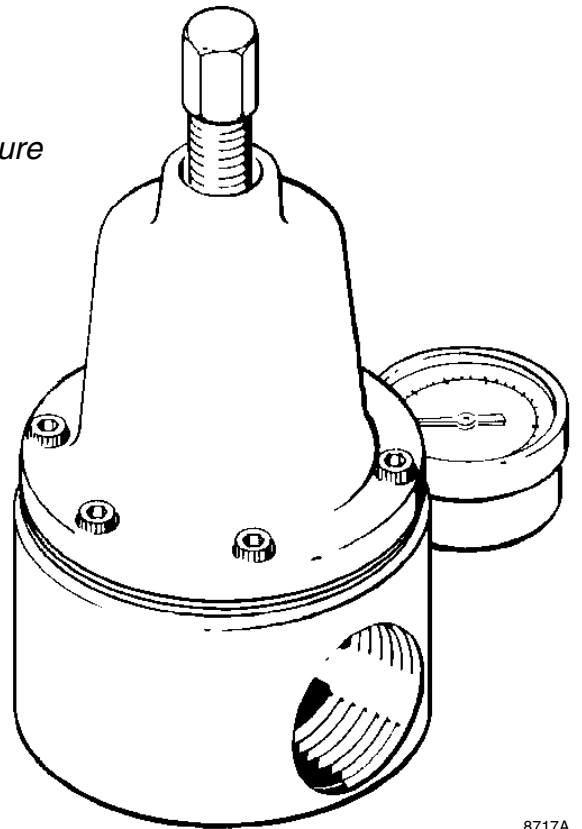

8717A

WARNING



INSTRUCTIONS

EQUIPMENT MISUSE HAZARD

Equipment misuse can cause the equipment to rupture, malfunction, or start unexpectedly and result in serious injury.

- This equipment is for professional use only.
- Read all instruction manuals, warnings, tags, and labels before operating the equipment.
- Use the equipment only for its intended purpose. If you are uncertain about usage, call your Graco distributor.
- Do not alter or modify this equipment. Use only genuine Graco parts and accessories.
- Check the equipment daily. Repair or replace worn or damaged parts immediately.
- Do not exceed the maximum working pressure of the lowest rated system component. The maximum inlet pressure of this equipment is 300 psi (2.1 MPa, 21 bar). See the **Technical Data** on page 7.
- Follow the **Pressure Relief Procedure** on page 4 if the spray tip clogs and before cleaning, checking or servicing the equipment.
- Route hoses away from traffic areas, sharp edges, moving parts, and hot surfaces.
- Do not expose Graco standard hoses to temperatures above 180°F (82°C) or below -40°F (-40°C).
- Do not use the hoses to pull the equipment.
- Use only fluids and solvents that are compatible with the equipment wetted parts. See the **Technical Data** sections of all the equipment manuals. Read the fluid manufacturer's warnings.
- Always wear protective eyewear, gloves, clothing, and respirator as recommended by the fluid and solvent manufacturers.
- Wear hearing protection when operating this equipment.
- Comply with all applicable local, state and national fire, electrical, and other safety regulations.

Installation

KEY

- A Fluid Supply Line
- B Air Spray Gun
- C Fluid Pressure Regulator
- D Air Supply Line
- E Adjusting Screw
- F Back Pressure Valve
- G Fluid Return Line

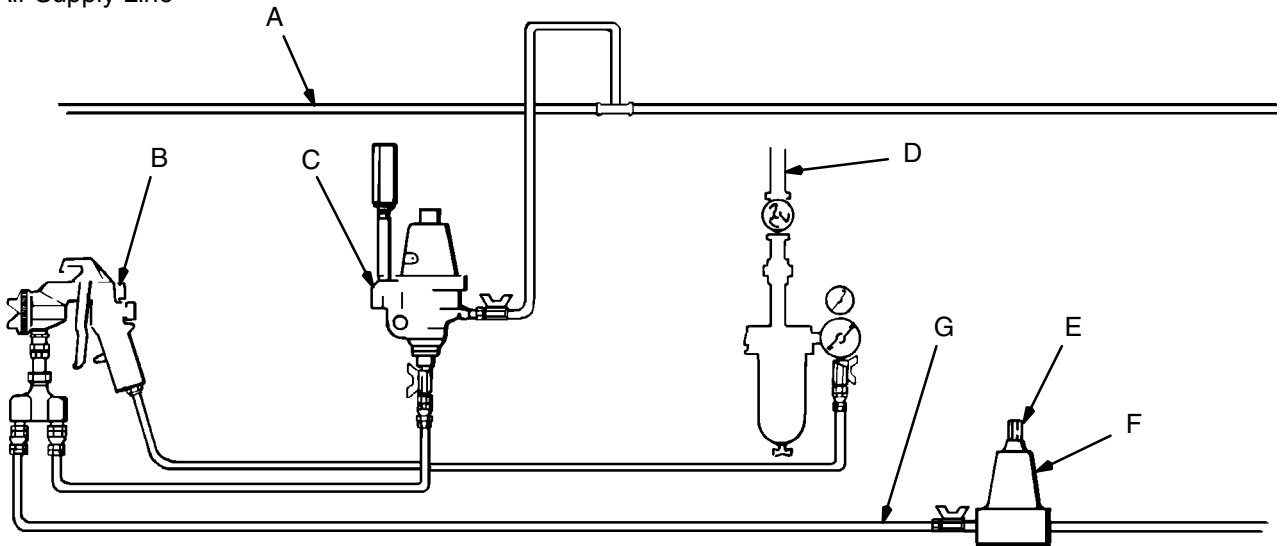

Fig. 1

8719A

⚠ CAUTION

Handle the back pressure valve with care to avoid damaging the diaphragm.

Connect the line to the 1-1/4 in. npt(f) inlet and outlet. Make sure the flow direction agrees with the IN and OUT markings on the valve body.

The back pressure valve is adjustable to control the fluid pressures in a circulating system from 5 to 200 psi (0.3 to 14 bar, 0.03 to 1.4 MPa).

Installing the Back Pressure Valve

Install the back pressure valve in the spray gun return line. See Fig. 1.

If more than one spray station is used, install the back pressure valve in the fluid supply line after the last station. This will help maintain proper circulating pressures in the system.

Operation

NOTE: The back pressure valve controls pressure ahead of its intake.

Turn the adjusting screw *clockwise* to increase pressure and *counterclockwise* to decrease pressure.

Adjust the pump pressure and back pressure valve for the best spraying combination and for proper circulation of fluid.

Flush the back pressure valve with a compatible solvent whenever the rest of the system or unit is being flushed. Open the back pressure valve before flushing by turning the screw *counterclockwise*.

Service

Pressure Relief Procedure

WARNING

PRESSURIZED EQUIPMENT HAZARD

The system pressure must be manually relieved to prevent the system from starting or spraying accidentally. To reduce the risk of an injury from accidental spray from the gun, splashing fluid, or moving parts, follow the **Pressure Relief Procedure** whenever you:

- are instructed to relieve the pressure,
- stop spraying,
- check or service any of the system equipment,
- or install or clean the spray nozzle.

1. Shut off the pump.
2. Open the dispensing valve, if used.
3. Open the fluid drain valve to relieve all fluid pressure, having a container ready to catch the drainage.

Service Procedure

NOTE: Regular cleaning and inspection of the valve, based upon the degree and kind of service, is essential.

1. Shut off the pump and open the back pressure valve by turning the adjusting screw (13) *counterclockwise* until no spring pressure is felt. Relieve all air and fluid pressures in the system.
2. Remove the back pressure valve from the fluid line.
3. Disassemble the valve and clean it with a suitable solvent. See the parts drawing, page 5.
4. Carefully inspect the diaphragm (12) for cracks or other damage. Replace if necessary.
5. Check for chips or dirt that could puncture the membrane or diaphragm before assembling the valve.
6. Check if the gasket (17) needs to be replaced.
7. Lubricate the threads of the diaphragm retainer (11).
8. Install the diaphragm parts onto the valve housing (15). Torque the retaining nut (20) to 10 to 12 ft-lb (13.5 to 16 N-m).
9. Carefully inspect the seat (10) for damage, wear, or dirt. These things could cause the regulated pressure to creep. Replace the seat if necessary.
10. Replace the seat gasket (14) when replacing the seat (10). Torque the seat to 15 to 20 ft-lb (21 to 27 N-m).
11. To remove or install the gauge (8), use the wrench on the square portion of the gauge stud only.
12. Lubricate both sides of the spring plate (7) and spring (5) with lithium-base grease.
13. Lubricate the adjusting screw threads.
14. Assemble the remaining parts.
15. Tighten the regulator cap screws (1) finger-tight, then torque them to 120 to 130 in-lb (13.6 to 14.7 N-m) in a criss-cross pattern. See the TOP VIEW in the parts drawing.
16. Install the back pressure valve back in the fluid line.

CAUTION

Use thread sealer sparingly on the gauge's male threads when installing it to avoid plugging the gauge.

Parts

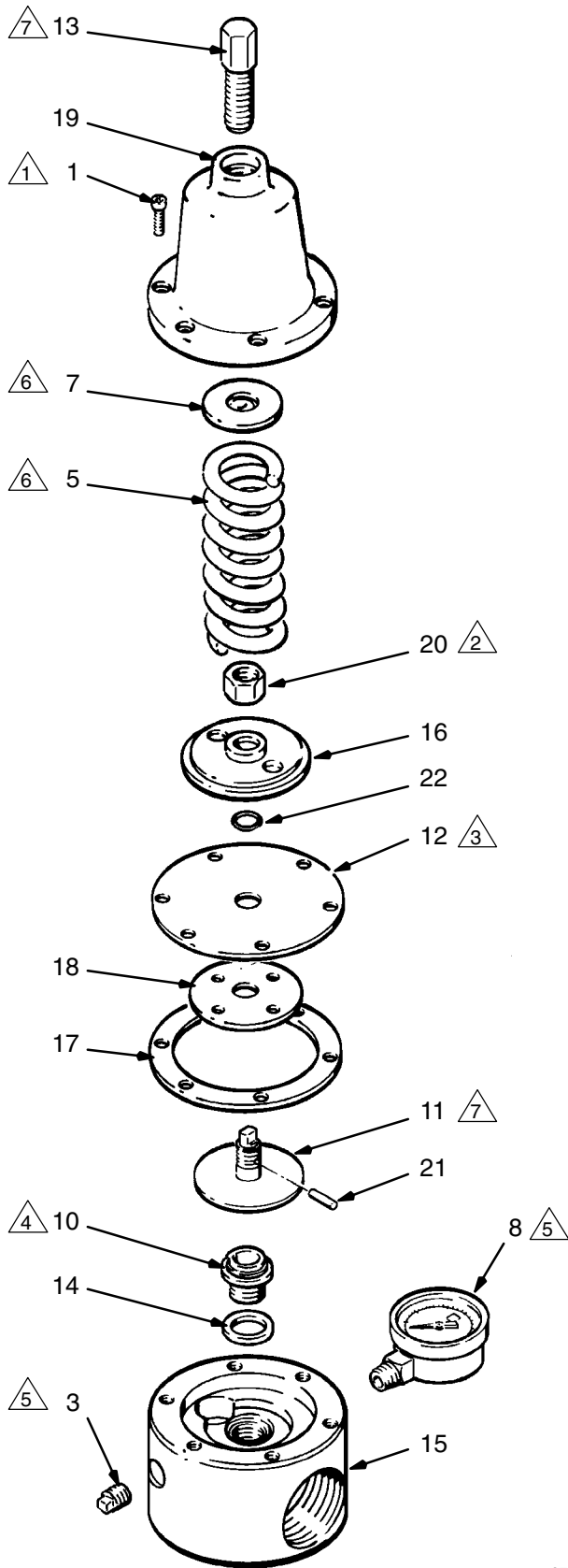

- △ 1 See TOP VIEW
- △ 2 Torque to 10–12 ft-lb (13.5–16 N-m)
- △ 3 PTFE side down
- △ 4 Torque to 15–20 ft-lb (21–27 N-m)
- △ 5 Apply anaerobic pipe sealant to threads
- △ 6 Apply lithium-base grease
- △ 7 Lubricate threads

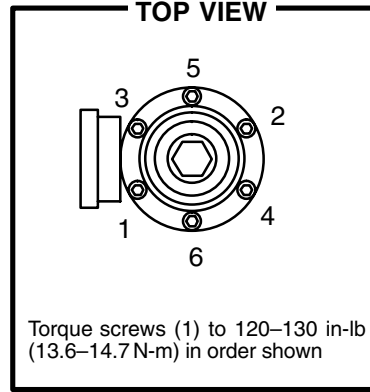

Model 916154 Stainless Steel Back Pressure Valve

Includes items 1 to 22

Ref. No.	Part No.	Description	Qty.
1	101682	SCREW, soc hd cap; 1/4–20 x 5/8	6
3	111697	PLUG, sq hd pipe; 1/4 npt	1
5	104144	SPRING, compression	1
7	160033	PLATE, spring	1
8✓	187873	GAUGE, 0 to 200 psi (0 to 1.4 MPa, 0 to 14 bar)	1
10✓	616439	SEAT, stainless steel & tungsten carbide	1
11	616440	RETAINER, diaphragm, stainless steel & tungsten carbide	1
12✓	172193	DIAPHRAGM	1
13	186872	SCREW, adjusting	1
14✓	171117	GASKET, acetal copolymer	1
15	187878	HOUSING	1
16	164864	PLATE, diaphragm	1
17✓	171912	GASKET, cellulose fibre	1
18✓	171913	GASKET, cellulose fibre	1
19	209027	CAP	1
20	160741	NUT, retaining	1
21	160742	PELLET, nylon	1
22	157277	O-RING, Thiokol®	1

8 These parts are included in Repair Kit 916139, which may be purchased separately.

✓ Keep these spare parts on hand to reduce down time.

8718A

Dimensions

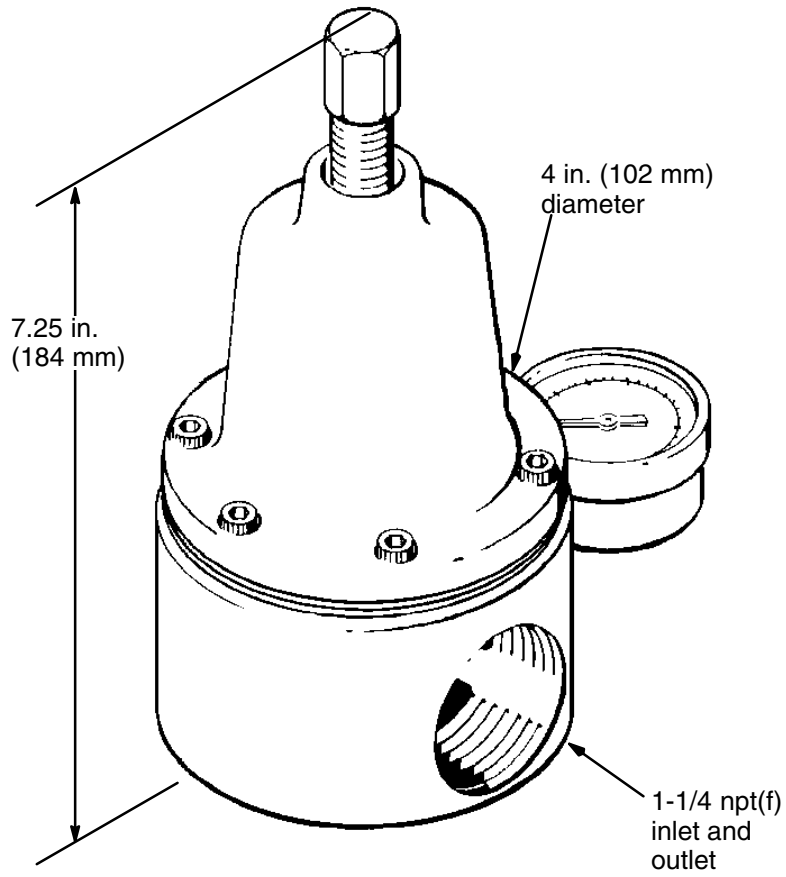

8717A

Technical Data

Maximum inlet pressure	300 psi (21 bar, 2.1 MPa)
Regulated pressure range	5 to 200 psi (0.3 to 14 bar, 0.03 to 1.4 MPa)
Inlet and outlet size	1-1/4 npt(f)
Gauge port size	1/4 npt(f)
Wetted parts	304 & 316 stainless steel, tungsten carbide, celcon <i>Diaphragm:</i> nylon fabric base, with impregnated buna-N, and material side is PTFE coated
Weight	8.5 lb (3.9 kg)

Thiokol® is a registered trademark of the Thiokol Chemical Corporation.

Graco Standard Warranty

Graco warrants all equipment manufactured by Graco and bearing its name to be free from defects in material and workmanship on the date of sale by an authorized Graco distributor to the original purchaser for use. With the exception of any special, extended, or limited warranty published by Graco, Graco will, for a period of twelve months from the date of sale, repair or replace any part of the equipment determined by Graco to be defective. This warranty applies only when the equipment is installed, operated and maintained in accordance with Graco's written recommendations.

This warranty does not cover, and Graco shall not be liable for general wear and tear, or any malfunction, damage or wear caused by faulty installation, misapplication, abrasion, corrosion, inadequate or improper maintenance, negligence, accident, tampering, or substitution of non-Graco component parts. Nor shall Graco be liable for malfunction, damage or wear caused by the incompatibility of Graco equipment with structures, accessories, equipment or materials not supplied by Graco, or the improper design, manufacture, installation, operation or maintenance of structures, accessories, equipment or materials not supplied by Graco.

This warranty is conditioned upon the prepaid return of the equipment claimed to be defective to an authorized Graco distributor for verification of the claimed defect. If the claimed defect is verified, Graco will repair or replace free of charge any defective parts. The equipment will be returned to the original purchaser transportation prepaid. If inspection of the equipment does not disclose any defect in material or workmanship, repairs will be made at a reasonable charge, which charges may include the costs of parts, labor, and transportation.

THIS WARRANTY IS EXCLUSIVE, AND IS IN LIEU OF ANY OTHER WARRANTIES, EXPRESS OR IMPLIED, INCLUDING BUT NOT LIMITED TO WARRANTY OF MERCHANTABILITY OR WARRANTY OF FITNESS FOR A PARTICULAR PURPOSE.

Graco's sole obligation and buyer's sole remedy for any breach of warranty shall be as set forth above. The buyer agrees that no other remedy (including, but not limited to, incidental or consequential damages for lost profits, lost sales, injury to person or property, or any other incidental or consequential loss) shall be available. Any action for breach of warranty must be brought within two (2) years of the date of sale.

Graco makes no warranty, and disclaims all implied warranties of merchantability and fitness for a particular purpose in connection with accessories, equipment, materials or components sold but not manufactured by Graco. These items sold, but not manufactured by Graco (such as electric motors, switches, hose, etc.), are subject to the warranty, if any, of their manufacturer. Graco will provide purchaser with reasonable assistance in making any claim for breach of these warranties.

In no event will Graco be liable for indirect, incidental, special or consequential damages resulting from Graco supplying equipment hereunder, or the furnishing, performance, or use of any products or other goods sold hereto, whether due to a breach of contract, breach of warranty, the negligence of Graco, or otherwise.

FOR GRACO CANADA CUSTOMERS

The parties acknowledge that they have required that the present document, as well as all documents, notices and legal proceedings entered into, given or instituted pursuant hereto or relating directly or indirectly hereto, be drawn up in English. Les parties conviennent avoir convenu que la rédaction du présente document sera en Anglais, ainsi que tous documents, avis et procédures judiciaires exécutés, donnés ou intentés à la suite de ou en rapport, directement ou indirectement, avec les procédures concernées.

Graco Information

For the latest information about Graco products, visit www.graco.com.

TO PLACE AN ORDER, contact your Graco distributor or call to identify the distributor closest to you:

Phone: 612-623-6921 or **Toll Free:** 1-800-328-0211 **Fax:** 612-378-3505

*All written and visual data contained in this document reflects the latest product information available at the time of publication.
Graco reserves the right to make changes at any time without notice.*

Original instructions. This manual contains English. MM 310537

Graco Headquarters: Minneapolis
International Offices: Belgium, China, Japan, Korea

GRACO INC. AND SUBSIDIARIES S P.O. BOX 1441 S MINNEAPOLIS, MN 55440-1441 S USA

Copyright 1996, Graco Inc. All Graco manufacturing locations are registered to ISO 9001.

www.graco.com

Revised May 2012