

# Trabon Divider Valves

312497ZAE

EN

**For series progressive oil and grease lubrication. For Professional Use Only.**



**Important Safety Instructions**  
Read all warnings and instructions in this manual. Keep these instructions.

## Models/Maximum Pressure

**Table 1: Maximum Operating Pressure**

Divider Type	Maximum Operating Pressure psi (MPa, bar)	Maximum Sections
<b>MD</b>	3000 (20.7, 207)	2
<b>MJ</b>	2000 (13.8, 138)	8
<b>MSP/MSPSS</b>	3500 (24.1, 241)	11/8
<b>MHH</b>	7500(51.7, 517)	8
<b>MX</b>	3000 (20.7, 207)	10
<b>MXP</b>	3000 (20.7, 207)	10
<b>MGO</b>	See Table 2	11

**Table 2: MGO Valves Maximum Operating Pressure**





Maximum Operating Pressure psi (MPa, bar)	Number of Sections
6000 (41.4, 414)	<b>3 to 7</b>
5500 (37.9, 379)	<b>8</b>
4000 (27.6, 276)	<b>9</b>
4500 (31.0, 310)	<b>10</b>
4000 (27.6, 276)	<b>11</b>

# Table of Contents

<b>Warnings</b> .....	<b>3</b>	<b>MHH Series</b> .....	<b>25</b>
<b>Installation</b> .....	<b>4</b>	Technical Specifications .....	25
Pressure Relief Procedure .....	4	Dimensions (inches / mm) .....	26
Setup .....	4	Parts .....	27
Component Identification .....	5	<b>MXP Series</b> .....	<b>28</b>
Divider Valves .....	5	Technical Specifications .....	28
Valve Sections (MSP, MHH, and MXP modular-type divider valves only) .....	5	Dimensions (inches / mm) .....	29
Pre-fill the Lubricant Distributor Lines .....	6	Parts .....	30
Fill the Secondary-to-Lube Point Lines .....	6	<b>MGO Series</b> .....	<b>31</b>
Fill the Master-to-Secondary Lube Lines .....	6	Technical Specifications .....	31
Fill the Master Divider Valve .....	7	Dimensions (inches / mm) .....	32
<b>Repair</b> .....	<b>8</b>	Parts .....	33
General Repair Instructions .....	8	<b>MX Series</b> .....	<b>34</b>
Purge Air From the System .....	8	Technical Specifications .....	34
Section 1: Purge Air from Secondary Divider Valve Lube-to-Lube Point Lines .....	9	Dimensions (inches / mm) .....	35
Section 2: Purge Air from Master to Secondary Divider Valve Lube Lines ..	10	Parts .....	36
Section 3: Purge Air from Pump to Master Divider Valve Lines .....	11	<b>Accessories</b> .....	<b>37</b>
Section 4: Purge Air After Addition or Replacement of a Master Divider Valve Module .....	12	Tube Clips .....	37
Section 5: Purge Air After Addition or Replacement of a Secondary Divider Valve Module .....	13	Mounting Bars .....	37
Location and Repair of Blockages .....	14	Mounting Brackets .....	37
Performance Indicators .....	14	Performance Indicators .....	37
Reset Indicator with Memory .....	14	Reset Indicator with Memory .....	37
Rupture Indicator .....	14	Automatic Relief Indicator .....	38
Automatic Relief Indicator .....	14	Rupture Indicator - MH Divider Valves Only .....	38
Locate and Repair Blockages .....	14	Rupture-to-Atmosphere Indicator .....	39
<b>MD Series</b> .....	<b>18</b>	Rupture-to-Atmosphere Indicator with Spud Assembly .....	39
Technical Specifications .....	18	Rupture Discs .....	40
Parts .....	18	Singling and Crossporting Bar Assemblies ..	40
Dimensions (inches / mm) .....	18	Cycle Indicators .....	40
<b>MJ Series</b> .....	<b>19</b>	Cycle Counters - Part No. 563444 .....	41
Technical Specifications .....	19	Cycle Switches .....	41
Dimensions (inches / mm) .....	19	Proximity Cycle Switches .....	42
Parts .....	20	Proximity Switch Connection Cables .....	43
<b>MSP Series/MSP SST Series</b> .....	<b>21</b>	Base Section Sub Assemblies .....	43
Technical Specifications .....	21	MSP Shunt Inlet and Zero-Leak Shut-Off Inlet .....	43
Dimensions (inches / mm) .....	22	<b>Maximum Cycle Rate and Flow Guidelines</b> .....	<b>46</b>
Parts .....	23	MGO .....	46
		MXP .....	46
		<b>California Proposition 65</b> .....	<b>47</b>
		<b>Graco Standard Warranty</b> .....	<b>48</b>

# Warnings

The following Warnings are for the setup, use, grounding, maintenance and repair of this equipment. The exclamation point symbol alerts you to a general warning and hazard symbols refer to procedure-specific risks. Refer back to these Warnings. Additional, product-specific warnings may be found throughout the body of this manual where applicable.

 <b>WARNING</b>	
	<p><b>EQUIPMENT MISUSE HAZARD</b></p> <p>Misuse can cause death or serious injury.</p> <ul style="list-style-type: none"> <li>• Do not operate the unit when fatigued or under the influence of drugs or alcohol.</li> <li>• Do not exceed the maximum working pressure or temperature rating of the lowest rated system component. See <b>Technical Specifications</b> in all equipment manuals.</li> <li>• Use fluids and solvents that are compatible with equipment wetted parts. See <b>Technical Specifications</b> in all equipment manuals. Read fluid and solvent manufacturer's warnings. For complete information about your material, request Safety Data Sheets (SDSs) from distributor or retailer.</li> <li>• Do not leave the work area while equipment is energized or under pressure.</li> <li>• Turn off all equipment and follow the <b>Pressure Relief Procedure</b> when equipment is not in use.</li> <li>• Check equipment daily. Repair or replace worn or damaged parts immediately with genuine manufacturer's replacement parts only.</li> <li>• Do not alter or modify equipment. Alterations or modifications may void agency approvals and create safety hazards.</li> <li>• Make sure all equipment is rated and approved for the environment in which you are using it.</li> <li>• Use equipment only for its intended purpose. Call your distributor for information.</li> <li>• Route hoses and cables away from traffic areas, sharp edges, moving parts, and hot surfaces.</li> <li>• Do not kink or over bend hoses or use hoses to pull equipment.</li> <li>• Keep children and animals away from work area.</li> <li>• Comply with all applicable safety regulations.</li> </ul>
  	<p><b>SKIN INJECTION HAZARD</b></p> <p>High-pressure fluid from dispensing device, hose leaks, or ruptured components will pierce skin. This may look like just a cut, but it is a serious injury that can result in amputation. <b>Get immediate surgical treatment.</b></p> <ul style="list-style-type: none"> <li>• Do not point dispensing device at anyone or at any part of the body.</li> <li>• Do not put your hand over the fluid outlet.</li> <li>• Do not stop or deflect leaks with your hand, body, glove, or rag.</li> <li>• Follow the <b>Pressure Relief Procedure</b> when you stop dispensing and before cleaning, checking, or servicing equipment.</li> <li>• Tighten all fluid connections before operating the equipment.</li> <li>• Check hoses and couplings daily. Replace worn or damaged parts immediately.</li> </ul>

# Installation

## Pressure Relief Procedure



Follow the Pressure Relief Procedure whenever you see this symbol.



This equipment stays pressurized until pressure is manually relieved. To help prevent serious injury from pressurized fluid, such as skin injection, splashing fluid and moving parts, follow the Pressure Relief Procedure when you stop spraying and before cleaning, checking, or servicing the equipment.

1. Verify that the pump feeding valve is stopped and either disconnected or locked out from its driver.
2. Using a wrench, slowly loosen the inlet nut.
3. Slowly loosen each port nut.

## Setup

The divider valve is shipped ready to install in the system. It has been factory-tested and should not require any additional modification.

**NOTE:** For MJ and MX series valves only: Gaskets (a) must be installed between every valve section (b) of the block assembly to prevent leaking.

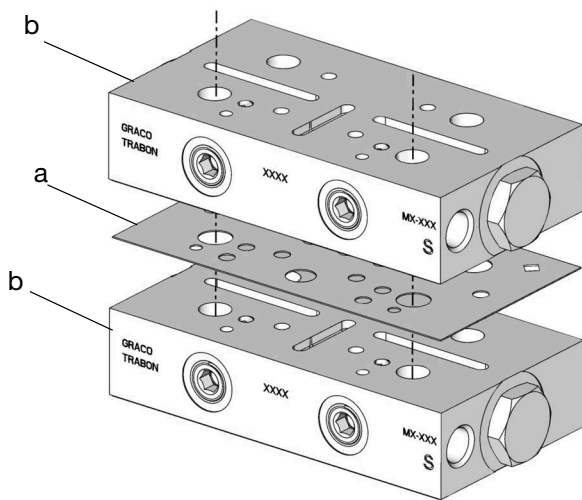

FIG. 1

### NOTICE

Do not install a divider valve into a system rated for more than the valve's maximum operating pressure. This type of installation could result in o-ring damage and cause the divider valve to leak.

To install the divider valve in the system:

1. Select a flat surface with no obstructions in front of it for installation. The valve orientation should be vertical with a minimal amount of tilt for proper valve operation, and with easy access to perform air purging procedure.
2. Install a rupture to atmosphere fitting with a blow-out disk rated for the maximum operating pressure of the weakest component between the force feed lubricator pump and the master divider valve inlet.
3. Install an analog pressure gauge at the inlet to the divider valve.
4. Torque, see Table 4 on page 16.

As long as lubricant is supplied under pressure to the inlet section of the divider assembly, the valve sections will continue to operate in a progressive manner. Divider assemblies always follow a constant discharge pattern. Whenever lubricant flow ceases, the valving pistons will stop. When flow resumes, it will start again at the same point in the discharge cycle.

## Component Identification

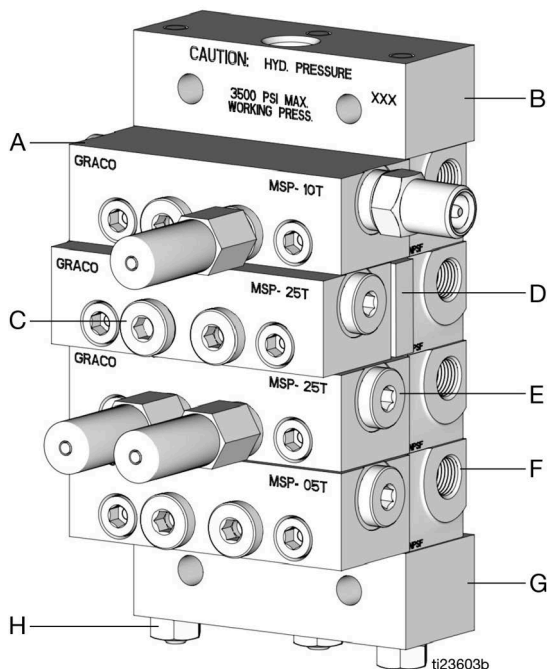

FIG. 2

### Key:

- A Valve Section
- B Inlet Section
- C Indicator / Port Plug
- D Crossport Plate
- E End Plug
- F Intermediate Section with Outlet Ports
- G End Section
- H Tie Rod Nut

Table 3: Typical Divider Valve Combinations

MASTER	SECONDARY	TYPE OF APPLICATION
MJ	MD	Machine tools, Printing, Wire Forging & Packaging Machinery
MSP	MJ, MSP	Machine tools, Textile, Glass & Can Machinery, Mobile Equipment
MX, MXP	MX, MXP, MSP	Cranes, Presses, Steel Mills, etc.
MGO	MX	Levellers, Shears, Conveyors, etc.

## Divider Valves

A Series-Flo type divider valve is a manifold proportioning device consisting of an inlet and end section plus a minimum of three valve sections. The divider valve is held together with tie rods and nuts. The master divider valve is the first divider valve downstream from the lube pump. A secondary divider valve is any divider valve receiving lubricant from the master divider valve.

### Valve Sections (MSP, MHH, and MXP modular-type divider valves only)

Valve sections (three (3) or more required per manifold) contain pistons specially fitted to that section. They also have built in outlet check valves and various passageways working with the pistons that meter and valve the flow of lubricant (FIG. 3).

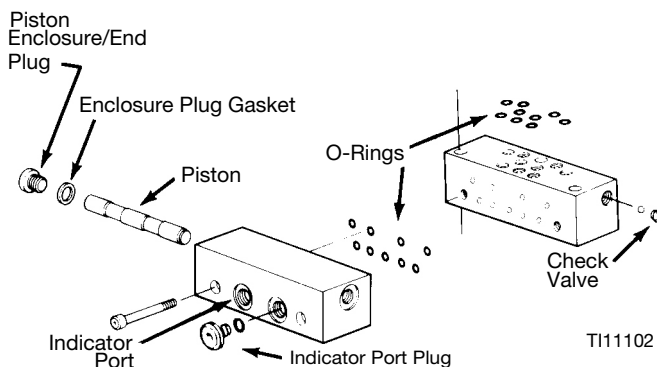

FIG. 3

Valve sections may be manufactured to require one (1) or two (2) lube outlets. Stamping located on the face of each section indicates:

- The style of divider valve section, such as MSP or MX.
- The discharge per piston stroke is expressed in thousandths of cubic inches (for example, 35 is 035 in<sup>3</sup>).
- The number of lube outlets required (S is single, one outlet only; T is twin, two lube outlets required)

## Pre-fill the Lubricant Distributor Lines

Follow the procedure exactly as written, in the order written.

### NOTICE

- The initial startup and operation is the most critical operating period for a newly installed machine in terms of potential for being damaged by unre-moved/unfiltered lubricant contaminants and lack of adequate lubrication. Proper pre-filling of lubrication system ensures that lubricant is immediately available to every lube point during machine startup, protecting them from damage.
- Use only clean oil filtered to the SAE recommended cleanliness level of ISO 18/14 (ISO Standard 4406) when pre-filling a system. The manufacturers of the machine tool and its component bearings should be consulted to ensure that the ISO 18/14 cleanliness level is adequate.

## Fill the Secondary-to-Lube Point Lines

Refer to FIG. 4 when performing this procedure

1. Remove port plugs or performance indicators from all of the indicator ports on the front of secondary divider valves.
2. Connect a hand pump filled with clean, filtered lubricant to the indicator port closest to the first line to be filled. The indicator port will correspond to the output port that is feeding the line being filled.
3. To verify that the lubricant is flowing and has reached the end of the lube line, loosen the connector at the lube point of the line being filled.
4. Stroke the hand pump until air-free lubricant is flowing from the end of the lube line.
5. Tighten the lube line connector at the lube point.

**NOTE:** Do not replace the port plugs or performance indicators into the ports on the front of the working section.

6. Repeat steps 1-5 for each of the other lube lines connected to the other outlet ports in the secondary divider valve assembly.
7. Repeat steps 1-5 for any other secondary divider assemblies in the system.

**NOTE:** Do not replace any of the performance indicators or port plugs removed in step 1 until the line-filling procedure described in **Fill the Master-to-Secondary Lube Lines** (pg. 6) has been completed.

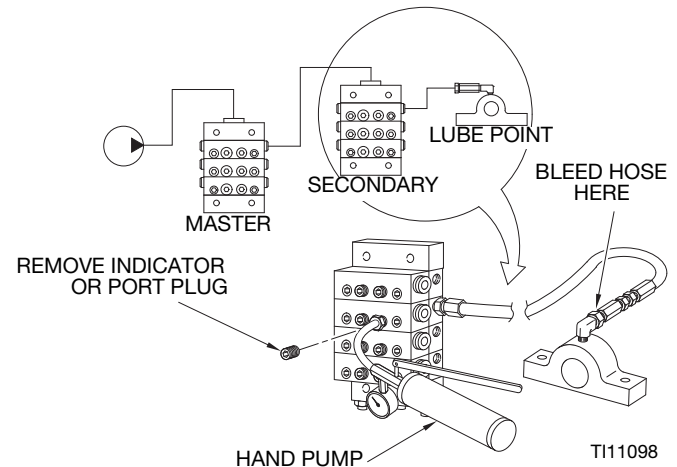

FIG. 4

## Fill the Master-to-Secondary Lube Lines

Refer to FIG. 5 when performing this procedure.

1. Remove the port plugs or performance indicators from all the indicator ports on the front of the master divider valve.
2. Connect a hand pump filled with clean, filtered lubricant to the indicator port closest to the lube output port that is feeding the line to the secondary divider valve.
3. Stroke the hand pump to fill the line between the master divider valve and the secondary divider valve.
4. Continue to stroke the pump until the lubricant purges all the air out of the internal passages of the secondary divider valve, and air-free lubricant flows easily from all indicator ports.
5. Reinstall the port plugs or performance indicators to their respective positions in the secondary divider valve.
6. Repeat steps 1-5 for each of the other lube lines between the master divider valve and all other secondary divider valves.

**NOTE:** Do not replace any of the performance indicators or port plugs removed in step 1 from the master divider valve assembly until the air-purging procedure described in **Fill the Master Divider Valve** (pg. 7) has been completed.

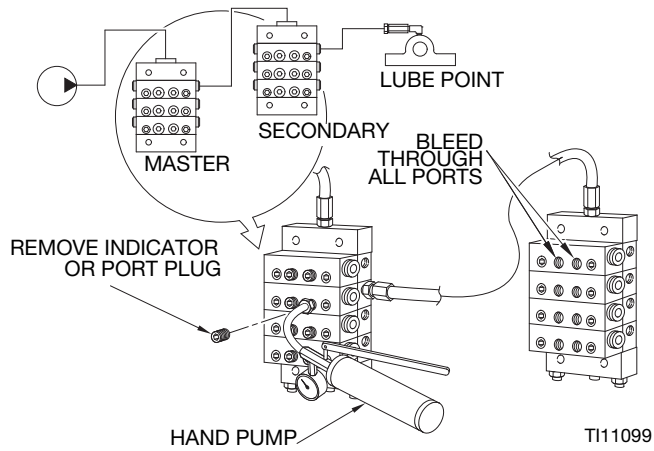

**FIG. 5**

### Fill the Master Divider Valve

Refer to FIG. 6. when performing this procedure.

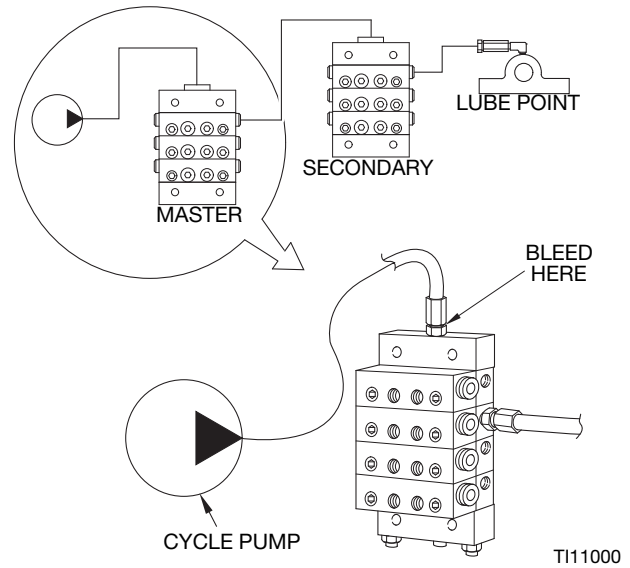

**FIG. 6**

1. Make sure that all of the port plugs or performance indicators have been removed from all of the indicator ports in the master divider valve.
2. Check that the system pump is properly connected to the inlet port of the master divider valve.
3. Cycle the system pump sufficiently to fill the main feeder line between the pump and the master divider valve, so that air-free lubricant discharges from all of the indicator ports on the front of the master divider valve.
4. Reinstall the master divider valve port plugs or performance indicators into their respective positions.

# Repair

## General Repair Instructions



- Before performing any repair procedures, follow the **Pressure Relief Procedure**, page 4.
- Pressure test distribution blocks yearly or every 8000 hours. Replace seals and divider valves as necessary.

## Purge Air From the System

Before machine operation resumes following maintenance or repair, perform manual system air purging.

There are several air purging procedures, depending upon the maintenance or repair procedure.

**NOTE:** Use only clean oil filtered to the SAE recommended cleanliness level of ISO 18/14 (ISO Standard 4406) when pre-filling a system. The manufacturers of the machine tool and its component bearings should be consulted to ensure that the ISO 18/14 cleanliness level is adequate.

Page	Section	Air purging after:
9	1	Replacing line between a secondary divider valve and lube point.
10	2	Replacing a line between the master divider valve and a secondary divider valve.
11	3	Replacing a line between pump and master divider valve.
12	4	Adding or replacing any component in a master divider valve assembly.
13	5	Adding or replacing any component in module in a secondary divider valve assembly.



## Section 1: Purge Air from Secondary Divider Valve Lube-to-Lube Point Lines

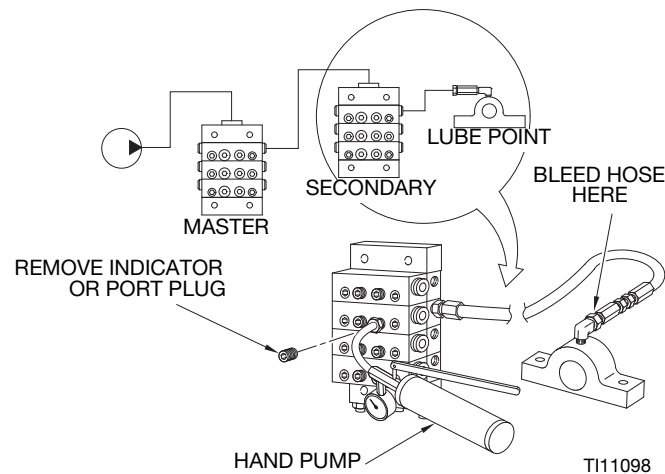

**FIG. 7**

Reference FIG. 7 when following this procedure.

1. Install the line from the secondary divider valve to the lube point, but do not completely tighten the connection at the lube point.
2. Remove the performance indicator port plug or the performance indicator from the working valve section on the secondary divider valve assembly corresponding to the outlet port and the line connected to the lube point.
3. Attach a hand pump filled with clean, filtered lubricant to the port on the secondary divider valve opened in step 2.
4. Operate the hand pump until air-free lubricant is observed flowing from the line at the lubrication point.
5. Tighten the fitting at the lubrication point while the lubricant is still flowing.
6. Remove the hand pump and reinstall the performance indicator or indicator port plug removed in step 2.

**NOTE:** If check valves were not installed at the lubrication point, lubricant may continually drain out of the line when the secondary port is open. When check valves are not used, the method for bleeding this line is to tighten the line at both ends and repeatedly cycle the secondary divider valve by hand pump operation until air-free lubricant flows from the lubrication point

## Section 2: Purge Air from Master to Secondary Divider Valve Lube Lines

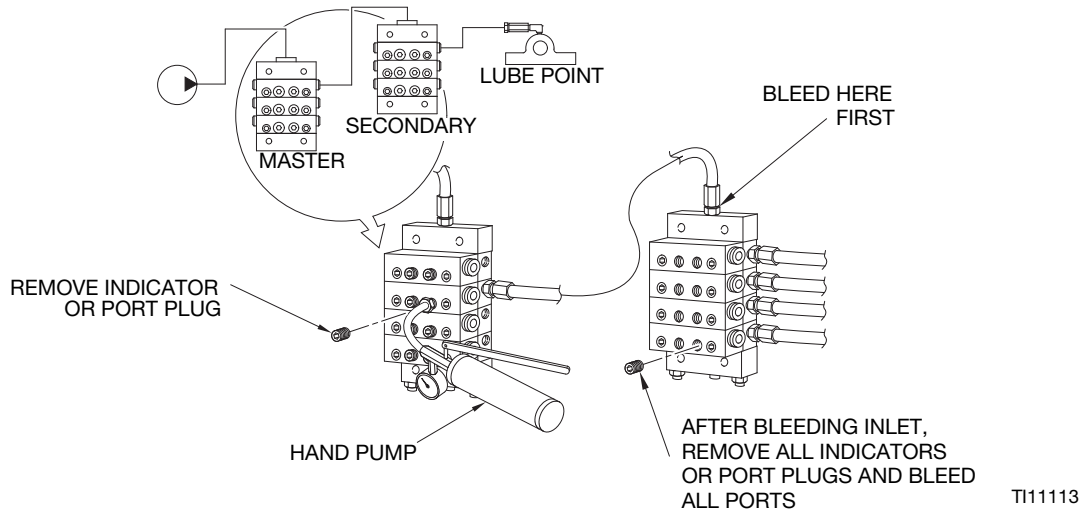
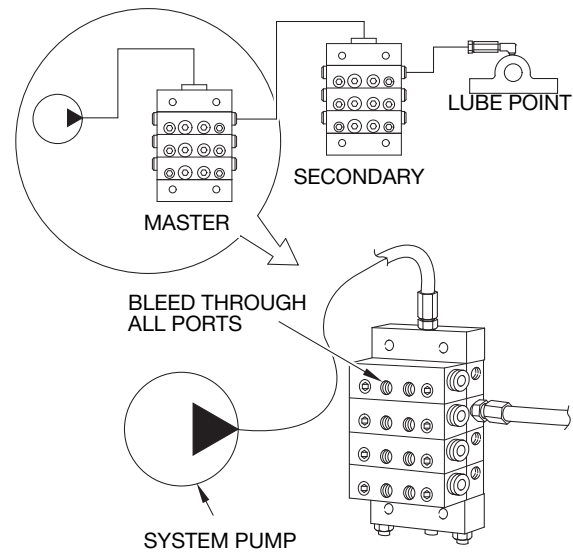

**FIG. 8**

Reference FIG. 8 when following this procedure.

1. Install the lines from the master divider valve to the secondary divider valve, but do not completely tighten the connection at the secondary divider valve inlet.
  2. Remove the performance indicator port plug or the performance indicator from the working valve section on the master divider valve assembly corresponding to the outlet port and the line connected to the secondary valve.
  3. Attach a hand pump filled with clean, filtered lubricant on the master divider valve opened in step 2.
  4. Operate the hand pump until air-free lubricant is observed flowing steadily from the secondary valve lube inlet connector.
  5. Tighten the fitting at the secondary valve inlet while the lubricant is still flowing.
  6. Remove all of the indicators or indicator port plugs from the secondary divider valve working sections.
  7. Operate the hand pump again until air-free lubricant flows out of all the secondary divider valve indicator ports.
  8. Reinstall all of the performance indicators or port plugs in the secondary divider valve while the lubricant is still flowing from the ports.
  9. Remove the hand pump and reinstall the performance indicator or indicator plug removed in step 2 into the master divider working valve open port.
- The system is now ready for operation.

### Section 3: Purge Air from Pump to Master Divider Valve Lines



TI11114

**FIG. 9**

Reference FIG. 9 when following this procedure.

1. Install the line from the system pump to the master divider valve, but do not completely tighten the connection at the master valve lube inlet.
2. Cycle the system pump until air-free lubricant flows from the line at the master divider valve lube inlet.
3. Tighten the fitting at the lube inlet port while the lubricant is still flowing.

The system is now ready for operation.

## Section 4: Purge Air After Addition or Replacement of a Master Divider Valve Module

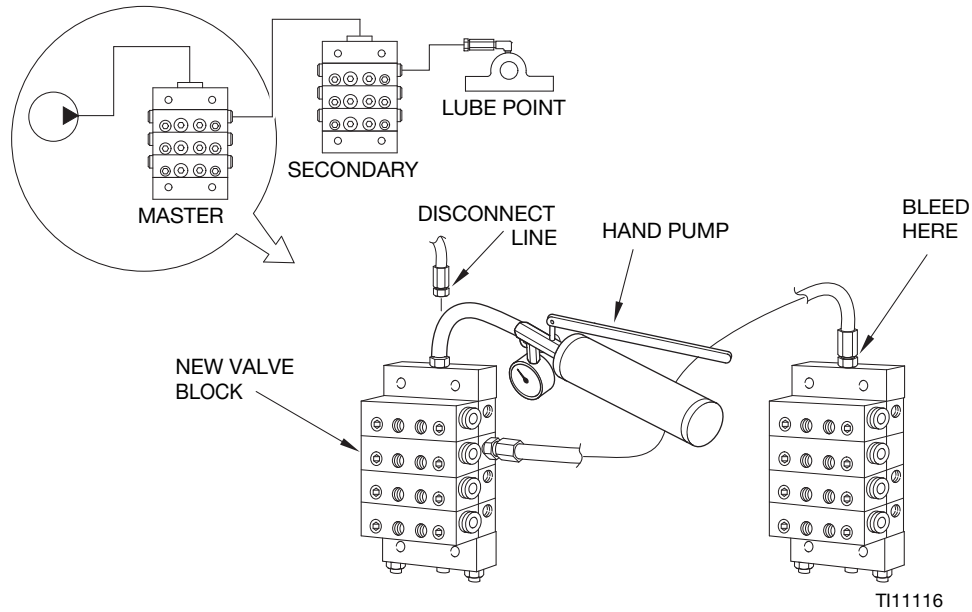

**FIG. 10**

Reference FIG. 10 when following this procedure.

1. Install the new or replacement module into the master divider valve assembly. Connect the tubing or hoses to the appropriate secondary divider valves or lubrication points if the new or replacement module is a base section.
2. Do not completely tighten the connections at the secondary divider valve inlet or at lubrication points.
3. Disconnect and remove the line from the pump at the inlet of the master divider valve.
4. Attach a hand pump filled with clean, filtered lubricant to the inlet port on the master divider valve.
5. Operate the hand pump until air-free lubricant flows from each secondary valve lube inlet connector and each lubrication point connector.
6. Tighten the fitting at the secondary valve inlet or at the lubrication port while lubricant is still flowing.
7. Remove the hand pump and reconnect the system pump to the inlet of the master divider valve.

The system is now ready for operation.

## Section 5: Purge Air After Addition or Replacement of a Secondary Divider Valve Module

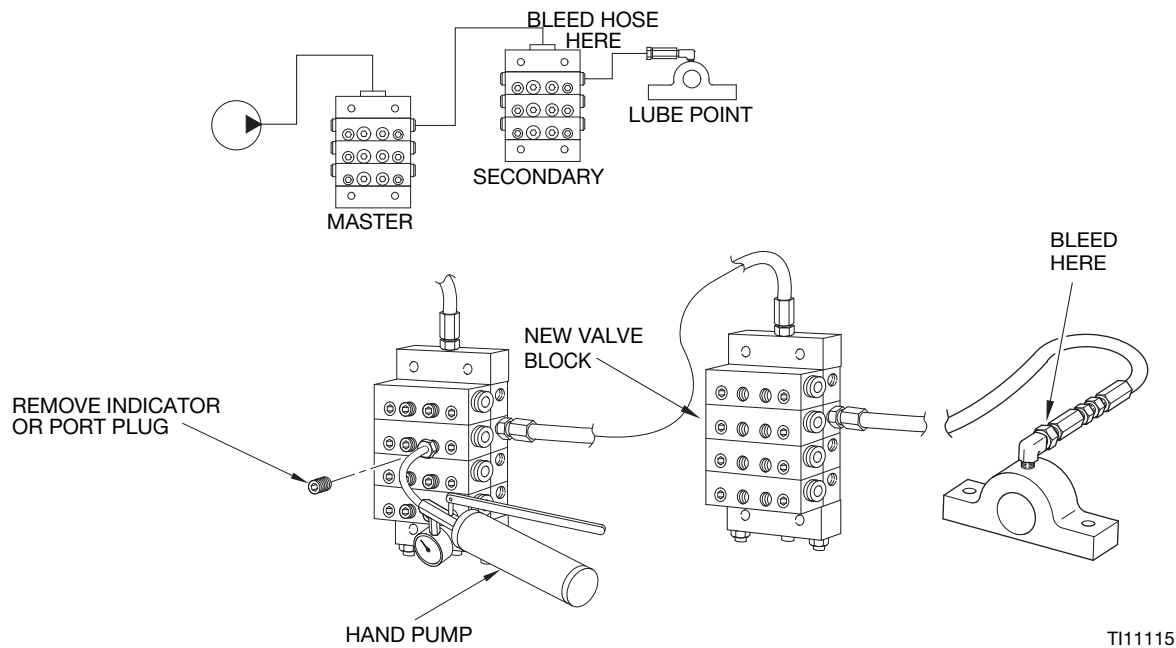

TI11115

**FIG. 11**

Reference FIG. 11 when following this procedure.

1. Install the new or replacement module to the secondary divider valve assembly. Connect the tubing or hoses to the appropriate lubrication point if the new or replacement module is a base section.
2. Do not completely tighten the connections at the lubrication point.
3. Remove the performance indicator or indicator port plug from the working valve section on the secondary divider valve assembly corresponding to the outlet port and the associated line.
4. Attach a hand pump filled with clean, filtered lubricant to the port on the secondary divider valve opened in step 3.
5. Operate the hand pump until air-free lubricant flows from the loosened connector at the lube point.
6. Tighten the fitting at the lube point while the lubricant is still flowing.
7. Repeat steps 3-6 for any additional lubrication points connected to the new module.
8. Remove the hand pump and reinstall the performance indicator or port plug removed in step 3 into the secondary divider valve open port.

The system is now ready for operation.

## Location and Repair of Blockages

Blockages cause a higher than normal pumping pressure. Depending upon the application or system design, a blockage may result in the complete loss of lubricant flow to the total system and prevent the bearings from receiving lubrication.

Loss of flow from blockage is indicated by a higher than normal system pressure from the pump attempting to overcome the blockage. Higher pressure is limited, isolated, and signaled through the use of various performance indicators, reset and relief, incorporated into the system design.

### Performance Indicators

Performance indicators are pressure-sensitive devices that pinpoint excessive pressure in the lubricating system.

Performance indicators are installed in the indicator ports of divider valves and signal a fault by either causing an indicator pin to extend or by releasing lubricant into the atmosphere.

**NOTE:** Never block a lube outlet designed to discharge lubricant.

### Reset Indicator with Memory

Reset indicators stop lube system operation when a fault occurs, and can be used in either master or secondary divider valves.

When a lube line is blocked, the resultant high pressure extends the indicator pin through the opening in the cap. High pressure prevents the affected divider valve piston from completing the cycle, causing a pressure backup through the divider valve which trips a pressure switch upstream from the valve and shuts off the pump.

The indicator pin remains extended until it is reset manually to show the lube line that is blocked.

## Rupture Indicator

Rupture indicators are used on MSP/MH divider valve applications where lube system pressure exceeds 2500 psi (17 MPa, 172 bar). High pressure from the lube line blockage may cause a disc to rupture. The lubricant then forces an indicator pin to extend, showing the blockage. The high pressure backs up through the system and trips a switch that turns the system off. When the fault is corrected, the disc must be replaced, and the pin reset manually.

## Automatic Relief Indicator

An automatic relief indicator pinpoints lube line blockage, but allows the lube system to continue supplying lubricant to points that are not blocked. They are used primarily in secondary divider valves. The excessive pressure created by line blockage moves a piston, enabling the lubricant to escape through a vent. When pressure is relieved the spring resets the piston. Because these indicators permit the lube system to continue operating when a lube point is blocked, a separate pressure switch connected to an audible or visual alarm should be used to warn of high pressure.

## Locate and Repair Blockages

1. Visually inspect the system to check for crushed lines or improper divider valve installation.
2. Make sure that each divider valve outlet required to discharge lubricant can.
3. Check that no pipe plugs are installed in an outlet designed to serve a bearing or another divider valve.
4. Use a manual pump with a gauge to fill the pump with clean, filtered lubricant. Connect the manual pump to the inlet of the master divider valve and slowly operate the pump. If the system does not cycle freely below 1500 psi, see **Master Divider Valve Equipped With Performance Indicator**, page 15.

**NOTE:** Use only clean oil filtered to the SAE recommended cleanliness level of ISO 18/14 (ISO Standard 4406) when pre-filling a system. The manufacturers of the machine tool and its component bearings should be consulted to ensure that the ISO 18/14 cleanliness level is adequate.

#### 4a. Master Divider Valve Equipped With Performance Indicator

With the manual pump connected to the master divider valve as outlined in step 3 of **Locate and Repair Blockages**, on page 14, raise the pressure to 2000 psi (14 MPa, 138 bar). The indicator ports signal the location of the blockage. An indicator in the up position means that pressure is in that outgoing line and signals the blockage is in the area being served from this outlet (FIG. 12).

If no indicator pins are protruding, the blockage is in the master divider valve.

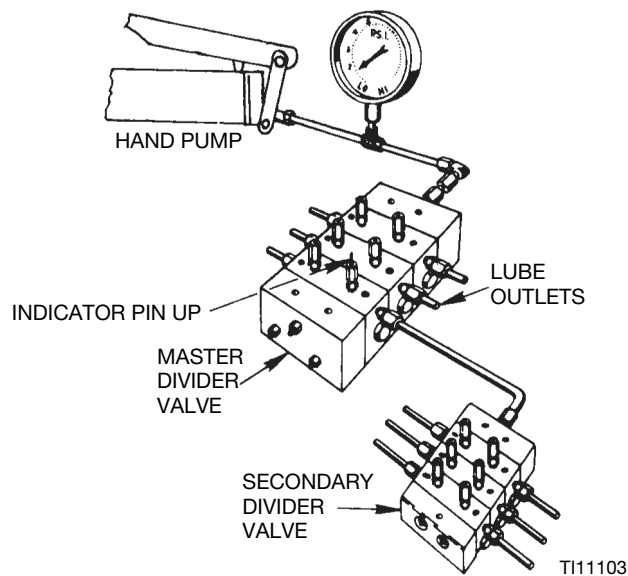

FIG. 12

#### 4b. Master Divider Valve Equipped Without Performance Indicator

- 1) With the manual pump connected to the master divider valve as outlined in step 3 of **Locate and Repair Blockages**, on page 14, raise the pressure to 2000 psi (14 MPa, 138 bar).
- 2) Remove each indicator port plug, one at a time, and attempt to operate the manual pump once each plug is removed. Do not exceed 2000 psi (14 MPa, 138 bar)
- 3) If the pressure drops and the master cycles freely after an indicator port plug is removed, then the blockage is downstream in the area being served from that outlet. See step 3 of **Locate and Repair Blockages**, on page 14.

#### NOTE:

- If all indicator port plugs are removed, the master will not cycle. The blockage is in this divider valve.
- When the indicator port plug of a blocked area is removed, a small amount of trapped lubricant usually surges out of this outlet as the inlet pressure on the divider valve drops.
- If testing (step 4) indicates a blockage in the master divider valve, disassemble and clean this divider valve. See step 7 of **Locate and Repair Blockages**, on page 16.

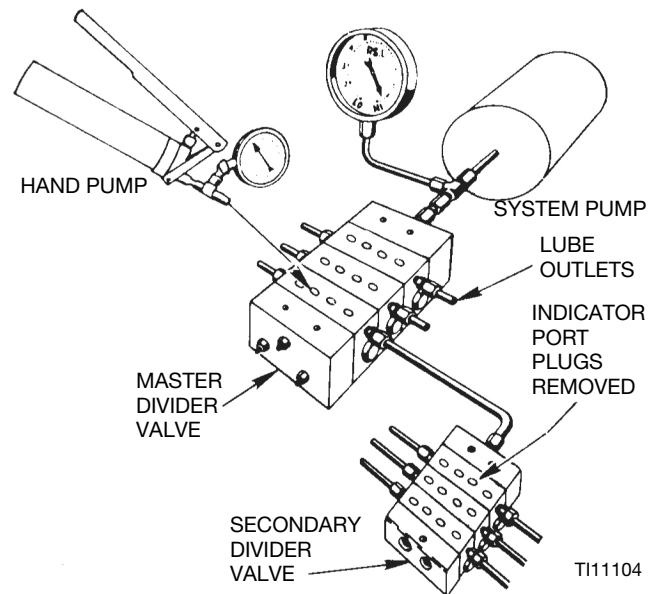

FIG. 13

5. If during step 4, a blockage is indicated downstream of the master divider valve, install a manual pump in the indicator port of the master divider valve that is common to the blocked area. (See FIG. 13).
  - a. Proceed to the downstream secondary divider valve and remove all indicator port plugs.
  - b. Slowly operate the manual pump. If lubricant discharges freely through each of the indicator ports of this divider valve, the blockage is not in the supply line or the divider valve. Go to step 6.

If the lubricant does not freely discharge through the open indicator ports of the second divider valve, the blockage is in this divider valve or the supply line. Disconnect the supply line at the secondary inlet fitting and slowly operate the manual pump to verify the blockage location. If the blockage is in this divider valve, go to step 7.

6. Install the manual pump into each indicator port of the secondary divider valve, in turn, and slowly operate the pump (FIG. 14). If high pressure exists, the blockage has been located. Look for crushed lines, tight bearings, and improperly drilled fittings and lube inlet ports. Correct as necessary.

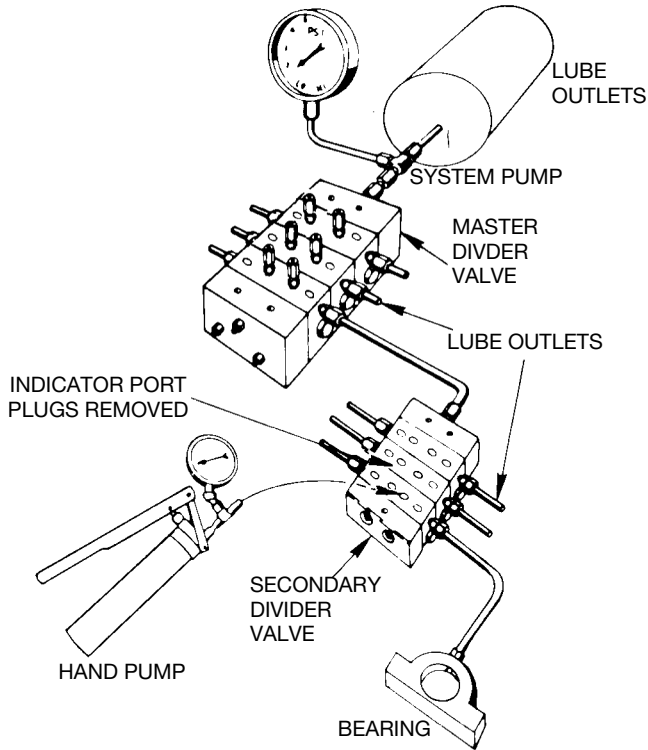

FIG. 14

7. Clean Divider Valve.

**NOTE:** Dirt and foreign material damage lubricating equipment. Perform all service and disassembly under the cleanest possible conditions.

**NOTE:** Take notes during the process to aid in reassembly.

- a. Before disassembling any divider valve, make a sketch noting the arrangement of the Valve Sections. For example: INLET 10T - 20S - 10T - 30S - END (FIG. 15). Only remove the end plugs. Try to move each piston back and forth without removing the piston from the valve section.

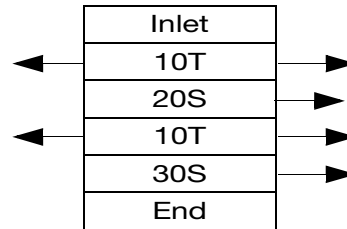

FIG. 15

**NOTICE**

Do not insert hard metal objects into piston bore (i.e., punches, screwdrivers, etc.). Hard metal objects can damage the surface and cause divider valves to leak fluid. Use a brass rod and hand pressure only.

- b. If all the pistons move freely and there is no indication of a more serious problem, replace the end plugs.
- c. Using a new gasket, tighten and torque as indicated in the table.

Table 4: Torque Values (\*see FIG. 2, page 5)

	Assembly Torque ft-lbs (N.m)						
	MJ	MD	MSP/MHH	MX	MXP	MGO	MSP-SST
Tie Rod Nuts	12 (16.3)	-	5-8 (6.8-10.9)	23 (31.2)	6-9 (8.1-12.2)	12 (16.3)	5-8 (6.8-10.9)
Indicator Plugs*	6-7 (8.1-9.5)	15 (20.3)	8-9 (10.9-12.2)	18 (24.4)	12-15 (16.3-20.3)	6-8 (8.1-10.9)	5-7 (6.8-9.5)
End Plugs*	7-11 (9.5-14.9)	-	12-15 (16.3-20.3)	46 (62.4)	46-50 (62.4-67.8)	15 (20.34)	6-8 (8.1-10.9)
Valve Section Mounting Screw	-	-	8-9 (10.9-12.2)	-	12-13 (16.3-17.6)	-	8-9 (10.9-12.2)



- d. Clean the sections and pistons using a suitable clean solvent until all of the lubricant has been removed.
- e. Use compressed air to dry and blow out all ports thoroughly.
- f. Use a small metal probe to ensure all the passages are clean and open.
- g. Inspect the cylinder bore and piston carefully for scratches, score marks or other damage.

**NOTE:** If either the piston or cylinder bore is damaged, install a new section. All pistons are selectively fitted to the bore for proper clearance. Be sure to reinstall the piston only into the valve section where it was removed.

- h. If the divider valve section and piston both appear in good condition, reassemble the section making sure the piston slides smoothly but snugly in the cylinder bore.
- i. Repeat the cleaning and inspection of each section.

After all sections have been cleaned, blown out, inspected and found to be in good condition, reassemble the divider valve.

**NOTE:**

- Always use new gaskets.
- Test the operation of divider valves using a manual pump.

**Contamination Blockage**

If dirt, foreign material, or any other form of contamination is found in a divider valve, cleaning that divider valve only temporarily solves contamination blockage problems. The source of the contamination must be discovered for satisfactory results.

Investigate the system filtering method. Inspect and clean, if necessary, the filter elements.

Review the reservoir filling method to remove the possibility of foreign material entering the reservoir during filling.

**Separation Blockage**

If a hard wax or soap-like material is found in the Valve Section, grease separation is occurring. This means the oil is being squeezed from the grease at normal system operating pressure and the grease thickener is being deposited in the divider valve. Cleaning the divider valve only temporarily solves the problem. Consult your lubricant supplier for recommendations on alternate lubricants and your local Graco/Trabon distributor to verify compatibility with centralized lubricating systems.

**NOTE:** If all indicator port plugs are removed, the master will not cycle. Blockage is in this divider valve (FIG. 12).

# MD Series

## Technical Specifications

Material	Steel
Pressure (max)	3,000 psi (20.7 MPA, 206.8 bar)
Lubricant	Oil or grease
Net Weight (approx.)	1-lb. 8 oz (0.68 kg)
Volume (Lubricant to cycle divider valve one complete cycle)	
MD-2, MD-3, MD-4	0.080 in. <sup>3</sup> (1.31 ccm)
MD-6	0.060 in. <sup>3</sup> (0.98 ccm)
Torque Ratings	
Assembly Bolts	8-9 ft. lbs (10.9-12.2 N.m)
Enclosure Plugs	7-11 ft. lbs (9.5-14.9 N.m)
Indicator Plug	15 ft. lbs (20.3 N.m)
Outlet Plugs	6-7 ft. lbs. (8.1-9.5 N.m)

## Dimensions (inches / mm)

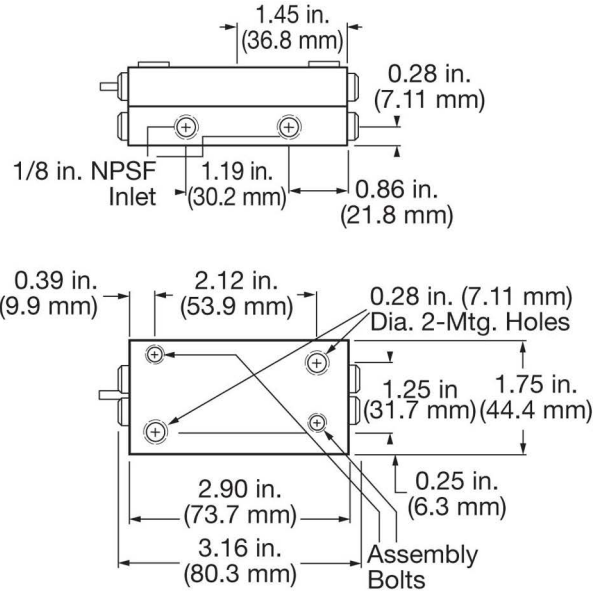

## Parts

Ref	Part No.	Description
1	562656	VALVE, feeder, MD 2
	562657	VALVE, feeder, MD 3
	562658	VALVE, feeder, MD 4
	562659	VALVE, feeder, MD 6
	562653	VALVE, feeder, MD 2, IND
	562654	VALVE, feeder, MD 3, IND
	562655	VALVE, feeder, MD 4, IND
	563270	VALVE, feeder, MD 2, IND/Switch
	563271	VALVE, feeder, MD 3, IND/Switch
	564356	VALVE, feeder, MD 4, IND/Switch

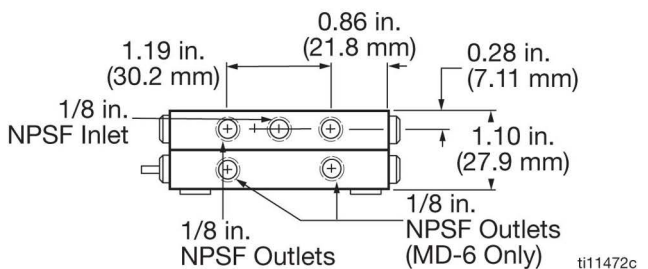
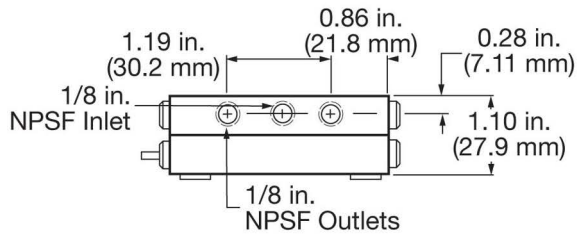
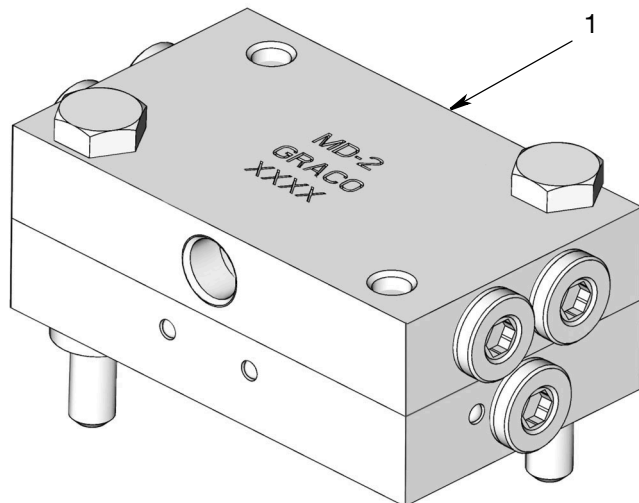

# MJ Series

## Technical Specifications

Material	Plated
Pressure (max)	2,000 psi (13.8 MPa, 137.9 bar)
Lubricant	Oil or grease up to NLGI Grade 1
Max Operating Temperature	200°F (93°C)
Max Cycle Rate With Cycle Pin	60 CPM
Net Weight (approx.)	
3 section divider valve	1-lb. 15 oz (0.88 kg)
4 section divider valve	2 lbs. 5 oz (1.04 kg)
5 section divider valve	2 lbs. 11 oz (1.21 kg)
6 section divider valve	3 lbs. 1 oz (1.38 kg)
7 section divider valve	3 lbs. 7 oz (1.55 kg)
8 section divider valve	3 lbs. 13 oz (1.72 kg)
Torque Ratings	
Tie Rod Nut	12 ft. lbs (16.3 N.m)
Enclosure Plug	7-11 ft. lbs (9.5-14.9 N.m)
Outlet Port Plugs	6-7 ft. lbs. (8.1-9.5 N.m)

## Dimensions (inches / mm)

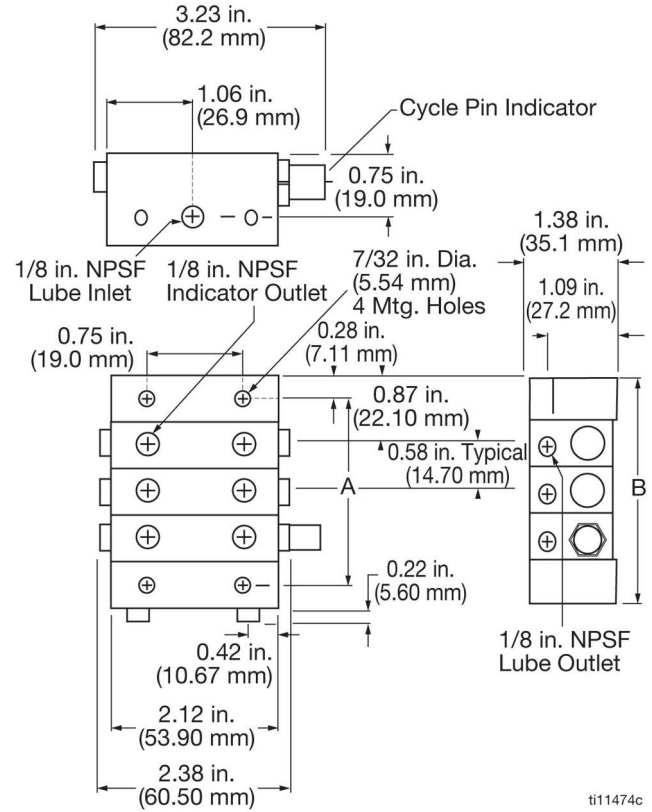

ti11474c

Divider Valve	Dimension A (approx.)		Dimension B	
	inch	mm	inch	mm
MJ-3	2.34	59.4	2.87	73.1
MJ-4	2.92	74.2	3.46	78.9
MJ-5	3.50	89.0	4.04	102.6
MJ-6	4.08	103.7	4.62	117.4
MJ-7	4.66	118.5	5.20	132.2
MJ-8	5.25	133.3	5.78	147.0

Parts

Ref	Part No.	Description
1*	562500	VALVE, assembly, MJ 5S
	562501	VALVE, assembly, MJ 10S
	562502	VALVE, assembly, MJ 15S
	562503	VALVE, assembly, MJ 5T
	562504	VALVE, assembly, MJ 10T
	562505	VALVE, assembly, MJ 15T
	562508	VALVE, assembly, IND MJ 10S
	562512	VALVE, assembly, IND MJ 10S Left
	562510	VALVE, assembly, IND MJ 10 T
	562513	VALVE, assembly, IND MJ 10T Left
	562509	VALVE, assembly, IND MJ 15S
	562511	VALVE, assembly, IND MJ 15T
	564205	VALVE, assembly, IND MJ 15T Left
2*	560643	INLET, CRS, MJ
3*	560645	END, CRS, MJ
4	557515	ROD, tie, MJ 3 (2 required)
	557516	ROD, tie, MJ 4 (2 required)
	557517	ROD, tie, MJ 5 (2 required)
	557518	ROD, tie, MJ 6 (2 required)
	557519	ROD, tie, MJ 7 (2 required)
	557520	ROD, tie, MJ 8 (2 required)
5	556371	NUT, tie rod, 1/4-28 (2 required)
6	557514	GASKET, feeder, MJ

\*Component is shipped with gasket

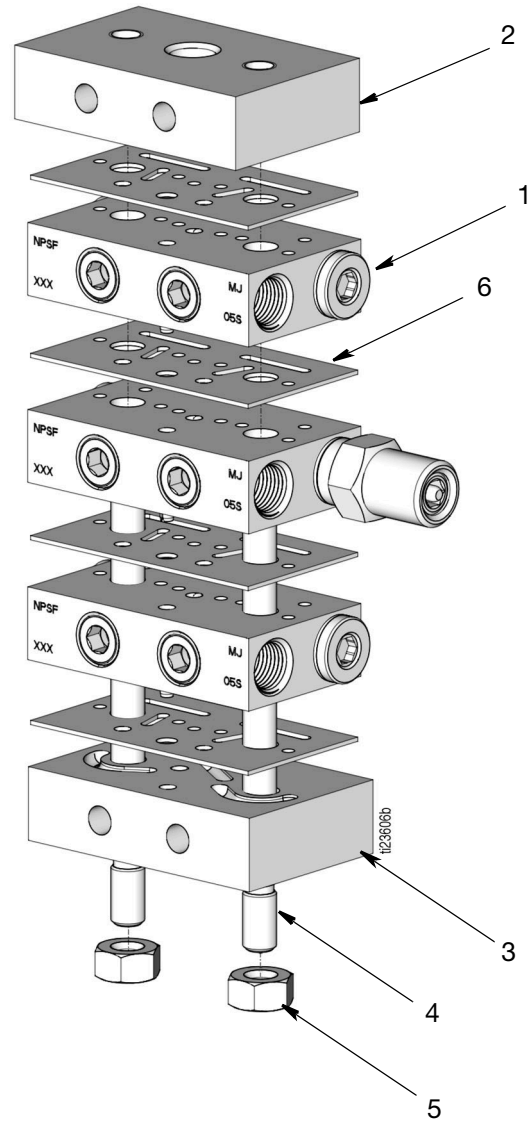

# MSP Series/MSP SST Series

## Technical Specifications

Material	Corrosion Protected Steel (optional: Type 303 Stainless Steel)
Pressure (max)	
MSP Valve	3500 psi (24.1 MPa, 241 bar)
Zero Leak Inlet	1500 psi (10.3 MPa, 103.4 bar)
Shunt/Shutoff Inlet	3500 psi (24.1 MPa, 241 bar)
Ambient Temperature (max)	140°F (60°C)
Lubricant	
Zero Leak Inlet	Oil Only - up to 5000 SUS, requires 25 micron (min) filtration
Shunt/Shutoff Inlet	Oil and fluid grease - filter oil through 25 micron filter and grease through 100 micron mesh strainer
New Weight (approx.)	
Carbon Steel	
3 section divider valve assembly	5.9 lbs (2.7 kg)
4 section divider valve assembly	7.3 lbs (3.3 kg)
5 section divider valve assembly	8.7 lbs (4.0 kg)
6 section divider valve assembly	10.2 lbs (4.6 kg)
7 section divider valve assembly	11.6 lbs (5.6 kg)
8 section divider valve assembly	13.0 lbs (5.9 kg)
Stainless Steel	
3 section divider valve assembly	8.2 lbs (3.7 kg)
4 section divider valve assembly	9.9 lbs (4.5 kg)
5 section divider valve assembly	11.7 lbs (5.3 kg)
6 section divider valve assembly	13.5 lbs (6.2 kg)
7 section divider valve assembly	15.2 lbs (6.9 kg)
8 section divider valve assembly	16.9 lbs (7.7 kg)
Torque Ratings	
Mounting Screw	8-9 ft. lbs (10.9-12.2 N.m)
Enclosure Plugs	6-8 ft. lbs (8.1-9.5 N.m)
Indicator Port Plug	5-7 ft. lbs (6.8-9.5 N.m)
Bleed Screws	1-2 ft. lbs. (1.4-2.7 N.m)
Tie Rod Nut	5-8 ft. lbs. (6.8-10.9 N.m)

**Dimensions (inches / mm)**

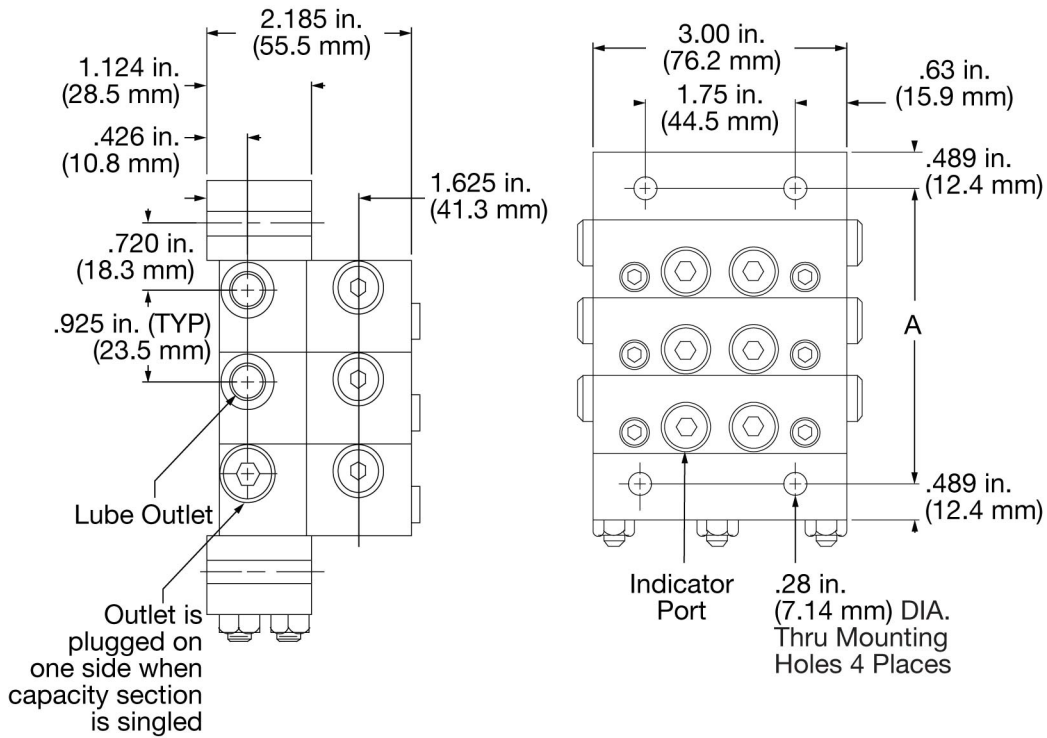

**Crossport Plate (Optional)**

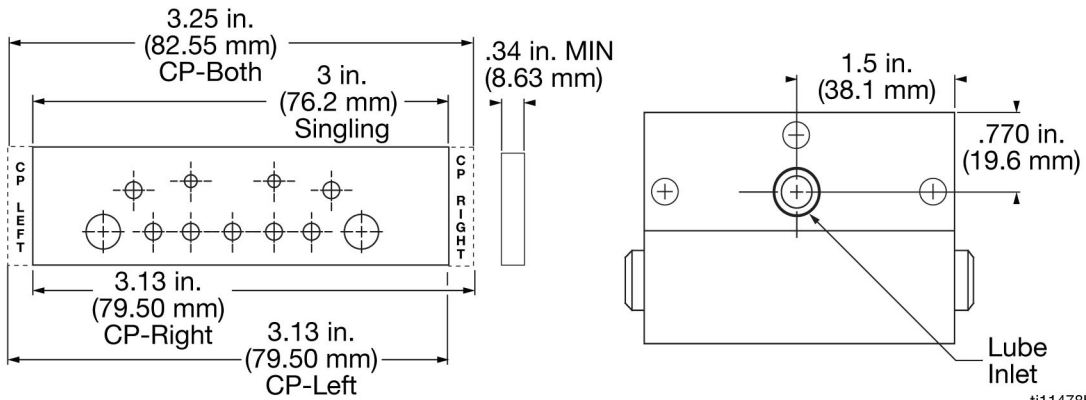

ti11478b

Number of Sections	Dimension A	
	inch	mm
3	3.60	91.3
4	4.52	114.8
5	5.45	138.3
6	6.37	161.8
7	7.3	185.3
8	8.22	208.8
9	9.15	232.3
10	10.07	255.8
11	11.00	279.3

Style	Tab(s)
CP Right	Right
CP Left	Left
CP-Both	Right and Left
Singling	None

## Parts

Ref	Part No.	Description
1	562711	VALVE, assembly MSP 05S
	562712	VALVE, assembly MSP 10S
	562713	VALVE, assembly MSP 15S
	562714	VALVE, assembly MSP 20S
	562715	VALVE, assembly MSP 25S
	562716	VALVE, assembly MSP 30S
	562717	VALVE, assembly MSP 35S
	562718	VALVE, assembly MSP 40S
	562720	VALVE, assembly MSP 05T
	562721	VALVE, assembly MSP 10T
	562722	VALVE, assembly MSP 15T
	562723	VALVE, assembly MSP 20T
	562724	VALVE, assembly MSP 25T
	562725	VALVE, assembly MSP 30T
	562726	VALVE, assembly MSP 35T
	562727	VALVE, assembly MSP 40T
	562729	VALVE, assembly IND MSP 20S
	562730	VALVE, assembly IND MSP 25S
	562731	VALVE, assembly IND MSP 30S
	562732	VALVE, assembly IND MSP 35S
	562733	VALVE, assembly IND MSP 40S
	562734	VALVE, assembly IND left MSP 20S
	562735	VALVE, assembly IND left MSP 25S
	562736	VALVE, assembly IND left MSP 30S
	562737	VALVE, assembly IND left MSP 35S
	562738	VALVE, assembly IND left MSP 40S
	562739	VALVE, assembly IND MSP 20T
	562740	VALVE, assembly IND MSP 25T
	562741	VALVE, assembly IND MSP 30T
	562742	VALVE, assembly IND MSP 35T
	562743	VALVE, assembly IND MSP 40T
	562744	VALVE, assembly IND left MSP 20T
	562745	VALVE, assembly IND left MSP 25T
	562746	VALVE, assembly IND left MSP 30T
	562747	VALVE, assembly IND left MSP 35T
	562748	VALVE, assembly IND left MSP 40T
	24B474	VALVE, assembly, MSP 05S - SST
	562755	VALVE, assembly, MSP 10S - SST
	24B475	VALVE, assembly, MSP 15S - SST
	562756	VALVE, assembly, MSP 20S - SST
	24B476	VALVE, assembly, MSP 25S - SST
	24B477	VALVE, assembly, MSP 30S - SST
	24B478	VALVE, assembly, MSP 35S - SST
	562757	VALVE, assembly, MSP 40S -SST
	24B479	VALVE, assembly, MSP 05T - SST
	562758	VALVE, assembly, MSP 10T - SST
	24B480	VALVE, assembly, MSP 15T - SST
	562759	VALVE, assembly, MSP 20T - SST
	24B481	VALVE, assembly, MSP 25T - SST

Ref	Part No.	Description
	24B482	VALVE, assembly, MSP 30T -SST
	24B483	VALVE, assembly, MSP 35T - SST
	562760	VALVE, assembly, MSP 40T - SST
2	24B497	BLOCK, base, MSP, NPTF, SST
	563425	BLOCK, base, MSP NPSF
	563447	BLOCK, base, MSP, BSPP
	563451	BLOCK, base, MSP, SAE
	563479	BLOCK, base, MSP w/No outlets
	24N369	BLOCK, base, MSP, BSPP, SST
3	560919	BLOCK, inlet, MSP, NPSF
	560936	BLOCK, inlet, MSP, BSPP
	560943	BLOCK, inlet, MSP, SAE
	560976	BLOCK, inlet, MSP, ISO 6149
	563421	BLOCK, inlet, MSP, NPSF, w/bleed
	563422	BLOCK, inlet, MSP SAE w/bleed
	15Y070	BLOCK, inlet, MSP, NPTF, SST
	16P368	BLOCK, inlet, MSP, BSPP, SST
4	563279	BLOCK, MSP end w/alt inlet
	563424	BLOCK, end, MSP
	24B498	BLOCK, end, MSP, SST
5	563469	KIT, crossport bar, right
	563470	KIT, crossport bar, left
	563471	KIT, crossport bar, both
	24R631	KIT, crossport, MSP, LH/RH, sst
	24R632	KIT, crossport, MSP, RH, sst
	24R633	KIT, crossport, MSP, LH, sst
6	563472	KIT, singling bar
7	562660	VALVE, assembly bypass, standard MSP
8	557731	ROD, tie, 3 section, MSP (3 required)
	557732	ROD, tie, 4 section, MSP (3 required)
	557733	ROD, tie, 5 section, MSP (3 required)
	557734	ROD, tie, 6 section, MSP (3 required)
	557735	ROD, tie, 7 section, MSP (3 required)
	557736	ROD, tie, 8 section, MSP (3 required)
	557738	ROD, tie, 9 section, MSP (3 required)
	557739	ROD, tie, 10 section, MSP (3 required)
	557740	ROD, tie, 11 section, MSP (3 required)
	126247	ROD, tie, 3 section, MSP, SST (3 required)
	126248	ROD, tie, 4 section, MSP, SST (3 required)
	126249	ROD, tie, 5 section, MSP, SST (3 required)
	126250	ROD, tie, 6 section, MSP, SST (3 required)
	126251	ROD, tie, 7 section, MSP, SST (3 required)
	126252	ROD, tie, 8 section, MSP, SST (3 required)
9	556371	NUT, 1/4 - 28 (3 required)
	558633	NUT, SST 1/4 - 28 light hex (3 required)

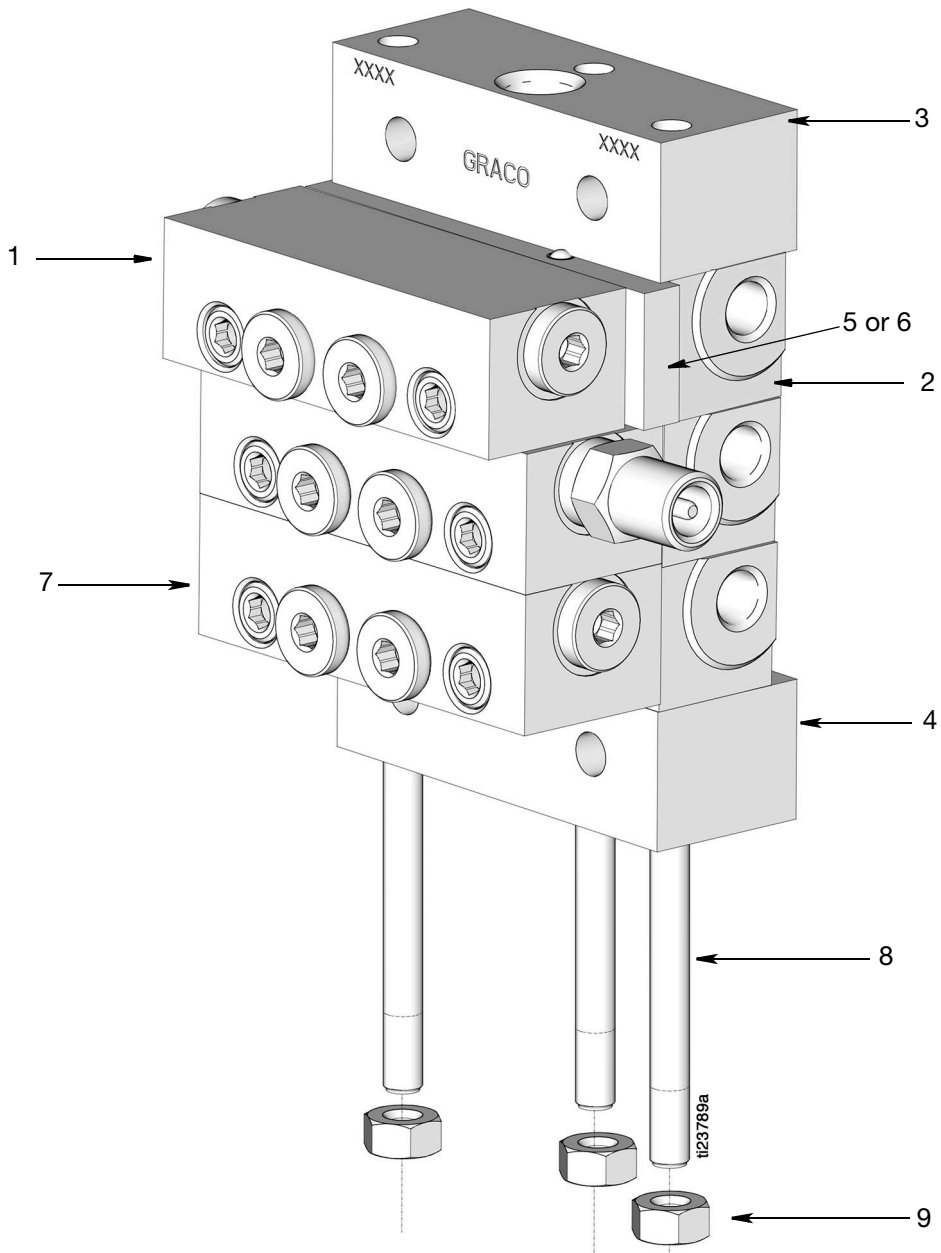



# MHH Series

## Technical Specifications

Material	Steel Body (corrosion protected) Steel Piston (honed fit)
Pressure (max)	7,500 psi (52 MPa, 517 bar) for Petroleum or Synthetic Oil - fluoroelastomer O-rings
Lubricant	Petroleum or synthetic oil only
Maximum Operating Temperature	
Fluoroelastomer O-rings (557722)	350°F (163°C)
Maximum Cycle Rate Without Cycle Pin	200 CPM
Net Weight (approx.)	
3 section divider valve assembly	5.9 lbs (2.7 kg)
4 section divider valve assembly	7.3 lbs (3.3 kg)
5 section divider valve assembly	8.7 lbs (4.0 kg)
6 section divider valve assembly	10.2 lbs (4.6 kg)
7 section divider valve assembly	11.6 lbs (5.6 kg)
8 section divider valve assembly	13.0 lbs (5.9 kg)
Torque Ratings	
Mounting Screw	8-9 ft. lbs (10.9-12.2 N.m)
Enclosure Plugs	6-8 ft. lbs (8.1-9.5 N.m)
Indicator Port Plug	5-7 ft. lbs (6.8-9.5 N.m)
Bleed Screws	1-2 ft. lbs. (1.4-2.7 N.m)
Tie Rod Nut	5-8 ft. lbs. (6.8-10.9 N.m)

**Dimensions (inches / mm)**

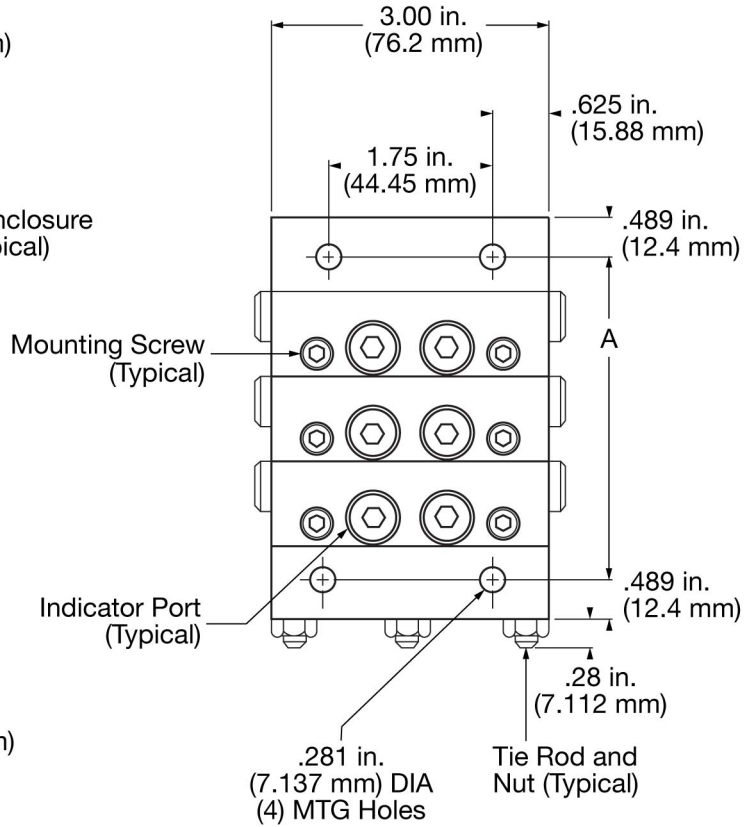
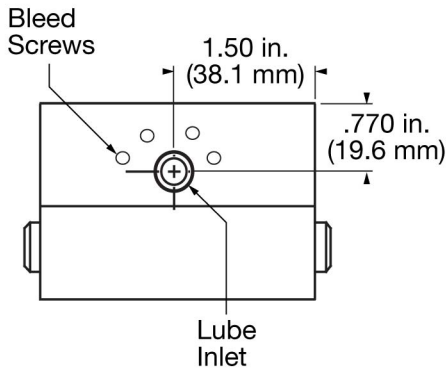
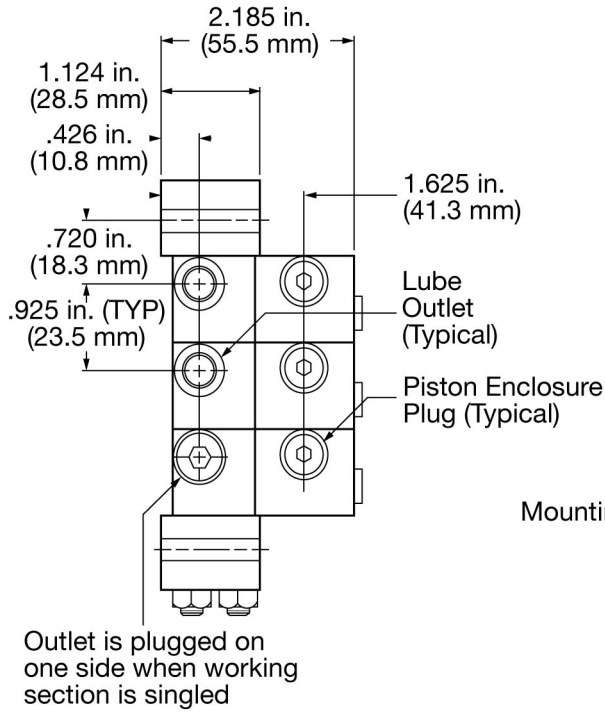

ti11480b

Number of Sections	Dimension A	
	inch	mm
3	3.60	91.3
4	4.52	114.8
5	5.45	138.3
6	6.37	161.8
7	7.3	185.3
8	8.22	208.8

Port Sizes	
Inlet	Outlet
1/4 - 18 (F) NPSF	1/8 - 27 (F): NPSF
7/16 - 20 (F) SAE	7/16 - 20 (F) SAE

Parts

Ref	Part No.	Description
1	562679	VALVE, assembly MHH 06S
	562680	VALVE, assembly MHH 09S
	562681	VALVE, assembly MHH 12S
	24X029	VALVE, assembly MHH 15S
	562682	VALVE, assembly MHH 18S
	24X030	VALVE, assembly MHH 21S
	562683	VALVE, assembly MHH 24S
	562684	VALVE, assembly MHH 30S
	562685	VALVE, assembly MHH 06I
	562686	VALVE, assembly MHH 09I
	562687	VALVE, assembly MHH 12I
	24X027	VALVE, assembly MHH 15I
	562688	VALVE, assembly MHH 18I
	24X028	VALVE, assembly MHH 21I
	562689	VALVE, assembly MHH 24I
	562690	VALVE, assembly MHH 30I
2	563425	BLOCK, base, MHH, NPSF
	563447	BLOCK, base, MHH, BSPP
	563451	BLOCK, base, MHH, SAE
	563479	BLOCK, base, MHH w/no outlets
3	560919	BLOCK, inlet, MHH, NPSF
	560936	BLOCK, inlet, MHH, BSPP

Ref	Part No.	Description
	560943	BLOCK, inlet, MHH, SAE
	560976	BLOCK, inlet, MHH, ISO 6149
	563421	BLOCK, inlet, MHH, NPSF, w/bleed
	563422	BLOCK, inlet, MHH SAE w/bleed
4	563279	BLOCK, MHH end w/alt inlet
	563424	BLOCK, end, MHH
5	563469	KII, crossport bar, right
	563470	KII, crossport bar, left
	563471	KII, crossport bar, both
6	563472	KII, singling bar
7	562660	VALVE, assembly bypass
8	557731	ROD, tie, 3 section (3 required)
	557732	ROD, tie, 4 section (3 required)
	557733	ROD, tie, 5 section (3 required)
	557734	ROD, tie, 6 section (3 required)
	557735	ROD, tie, 7 section (3 required)
	557736	ROD, tie, 8 section (3 required)
	557738	ROD, tie, 9 section (3 required)
	557739	ROD, tie, 10 section (3 required)
	557740	ROD, tie, 11 section (3 required)
9	556371	NUT, 1/4 - 28 (3 required)

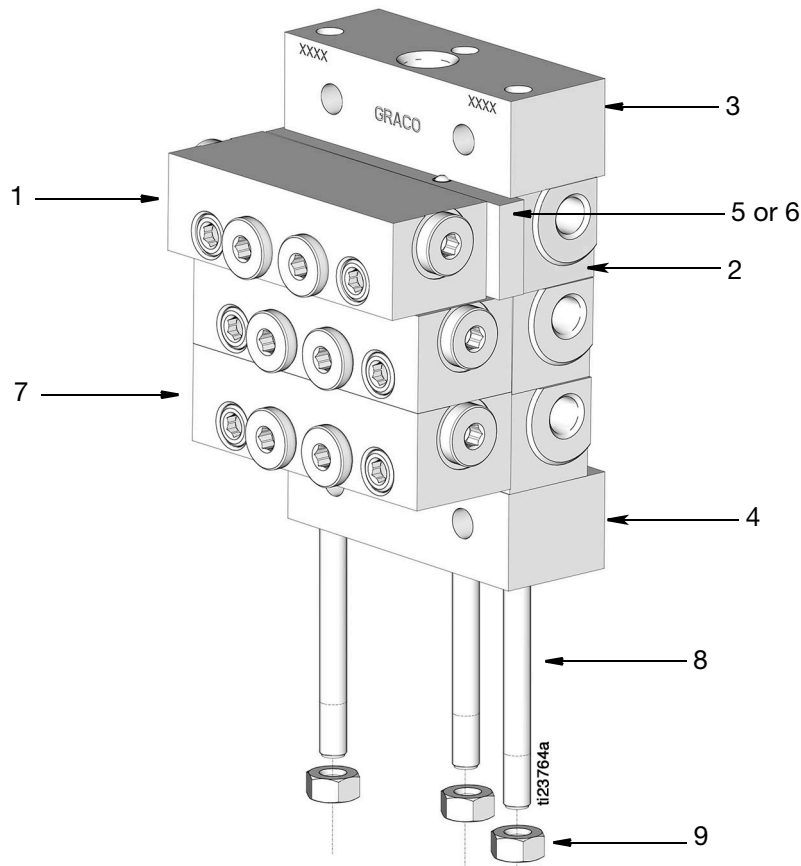

# MXP Series

## Technical Specifications

Material	Zinc Plated Steel
Pressure (max)	3,000 psi (20.7 MPa, 206.8 bar)
Lubricant	Oil or grease
Maximum Operating Temperature	350°F (177°C)
Maximum Cycle Rate With Cycle Pin	60 CPM
Maximum Cycle Rate Without Cycle Pin or With Prox Cycle Switch	110-200 CPM*
Net Weight (approx.)	
3 section divider valve assembly	18-lb. 2 oz (8.3 kg)
4 section divider valve assembly	22 lbs. 6 oz (10.2 kg)
5 section divider valve assembly	26 lbs. 9 oz (12.2 kg)
6 section divider valve assembly	31 lbs. 3 oz (14.2 kg)
7 section divider valve assembly	35 lbs. 6 oz (16.2 kg)
8 section divider valve assembly	39 lbs. 9 oz (18.1 kg)
9 section divider valve assembly	44 lbs. 3 oz (20.1 kg)
10 section divider valve assembly	48 lbs. 6 oz (22.1 kg)
Torque Ratings	
Tie Rod Nut	6-9 ft. lbs (8.1-12.2 N.m)
Enclosure Plugs	48 +/- 2 ft. lbs (65 N.m)
Indicator Plug	12 -15 ft. lbs (16.3-20.3 N.m)
Valve Section Mounting Screw	12-13 ft. lbs. (16.3-17.6 N.m)

\* See Cycle Rate and Flow Guidelines Table, page 44.

**Dimensions (inches / mm)**

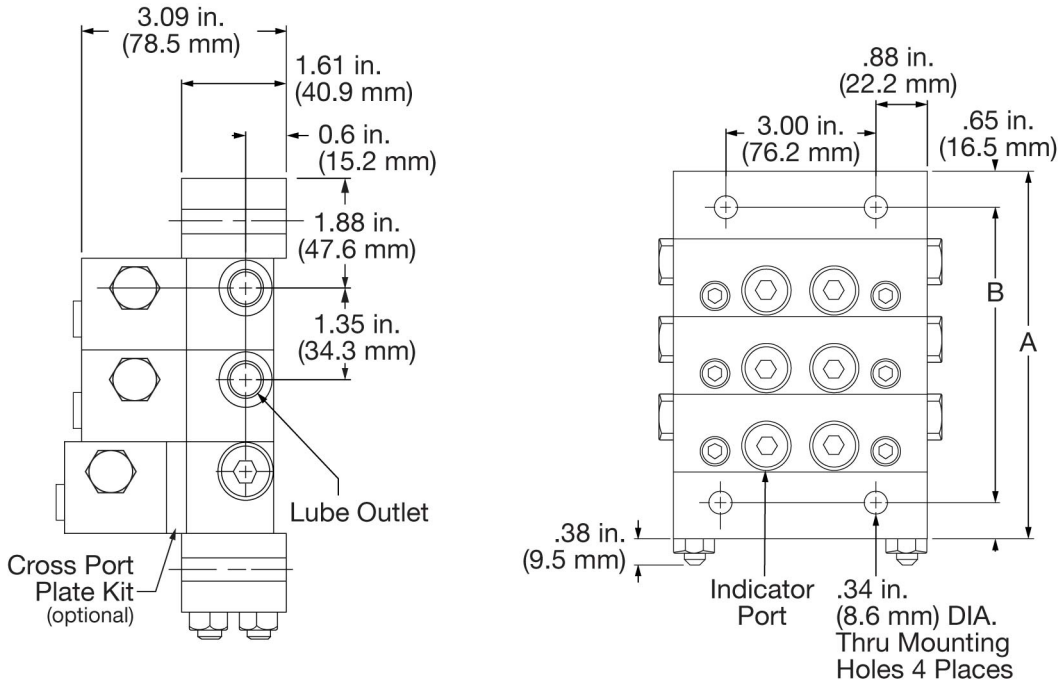

**Crossport Plate (Optional)**

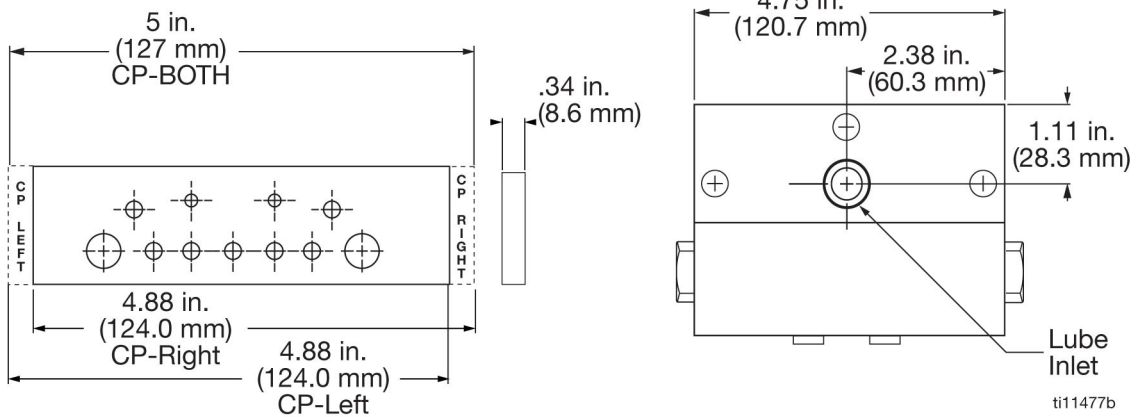

Number of Sections	Dimension A		Dimension B		Weight	
	inch	mm	inch	mm	pound	kg
3	6.64	168.6	5.34	135.6	18.2	8.3
4	7.99	202.8	6.69	169.8	22.6	10.2
5	9.33	237.0	8.03	204.0	26.9	12.2
6	10.68	271.2	9.38	238.2	31.3	14.2
7	12.03	305.5	10.73	272.4	35.6	16.2
8	13.37	339.7	12.07	306.7	39.9	18.1
9	14.72	373.9	13.42	340.9	44.3	20.1
10	16.07	408.1	14.77	375.1	48.6	22.1

Style	Tab(s)
CP Right	Right
CP Left	Left
CP-Both	Right and Left

Parts

Ref	Part No.	Description
1	562813	VALVE, twin, .025 MXP
	562814	VALVE, twin, .050 MXP
	562815	VALVE, twin, .075 MXP
	562816	VALVE, twin, .100 MXP
	562817	VALVE, twin, .125 MXP
	562818	VALVE, twin, .150 MXP
	562819	VALVE, single, .025 MXP
	562820	VALVE, single, .050 MXP
	562821	VALVE, single, .075 MXP
	562822	VALVE, single, .100 MXP
	562823	VALVE, single, .125 MXP
	562824	VALVE, single, .150 MXP
	562825	VALVE, twin, .050 MXP w/indicator
	562826	VALVE, twin, .075 MXP w/indicator
	562827	VALVE, twin, .100 MXP w/indicator
	562828	VALVE, twin, .125 MXP w/indicator
	562829	VALVE, twin, .150 MXP w/indicator
	562830	VALVE, single, .050 MXP w/indicator
	562831	VALVE, single, .075 MXP w/indicator
	562832	VALVE, single, .100 MXP w/indicator
	562833	VALVE, single, .125 MXP w/indicator

Ref	Part No.	Description
	562834	VALVE, single, .150 MXP w/indicator
2	563519	BLOCK, BSPLT interm MXP 1/4 NPSF
	563521	BLOCK, BSPLT interm MXP SAE
	563522	BLOCK, BSPLT interm MXP 1/4 BSPP
	563479	BLOCK, base, MSP/MHH w/no outlets
3	15R994	BLOCK, inlet, MXP
	15R993	BODY, inlet, MXP
	561029	BLOCK, sect MXP inlet BSPP thread
4	563518	BLOCK, end, machine MX
5	563524	KIT, MXP, crossport bar, left
	563525	KIT, MXP, crossport bar, right
	563526	KIT, MXP, crossport bar, both
6	15R997	BLOCK, bypass, MXP
7	557766	ROD, tie, 3 section, MXP (3 required)
	557767	ROD, tie, 4 section, MXP (3 required)
	557768	ROD, tie, 5 section, MXP (3 required)
	557769	ROD, tie, 6 section, MXP (3 required)
	557770	ROD, tie, 7 section, MXP (3 required)
	557771	ROD, tie, 8 section, MXP (3 required)
	557772	ROD, tie, 9 section, MXP (3 required)
	563520	ROD, tie, 10 section, MXP (3 required)
8	555406	NUT, 5/16 - 24 light hex (3 required)

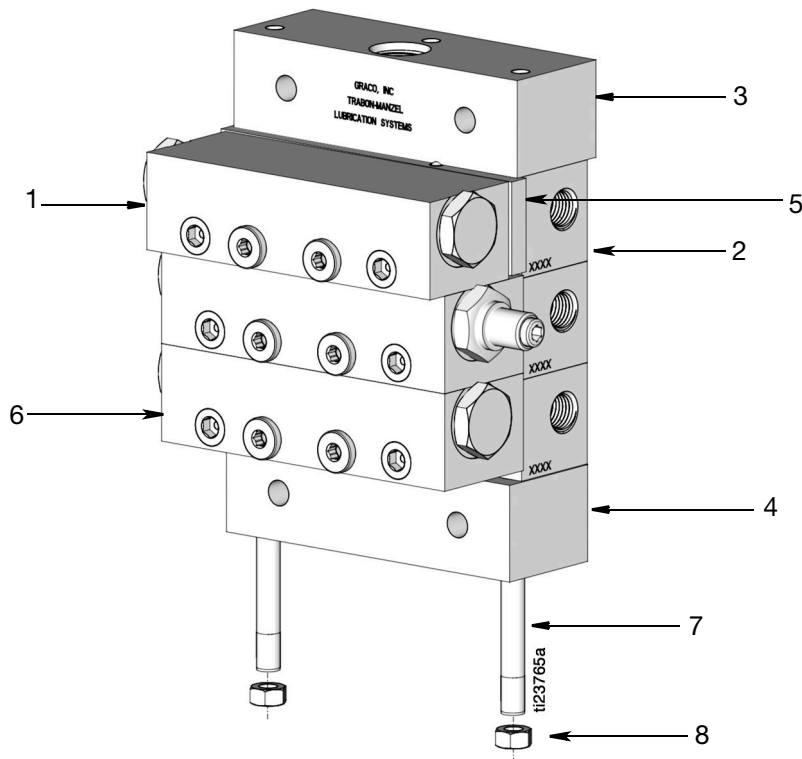

# MGO Series

## Technical Specifications

Material	Zinc Plated Steel and Phosphate Coated Cast Iron
Pressure (max)	
3-7 section divider valve assembly	6000 psi (41 MPa, 414 bar)
8 section divider valve assembly	5500 psi (38 MPa, 379 bar)
9 section divider valve assembly	5000 psi (34 MPa, 345 bar)
10 section divider valve assembly	4500 psi (31 MPa, 310.3 bar)
11 section divider valve assembly	4000 psi (27 MPa, 27.6 bar)
Lubricant	Oil or grease
Maximum Operating Temperature	200°F (93°C)
Maximum Cycle Rate With Cycle Pin	60 CPM
Maximum Cycle Rate Without Cycle Pin or With Prox Cycle Switch	240-185 CPM*
Net Weight (approx.)	
3 section divider valve assembly	45-lb. (20.41 kg)
4 section divider valve assembly	53 lbs. 5 oz (24.18 kg)
5 section divider valve assembly	61 lbs. 10 oz (27.95 kg)
6 section divider valve assembly	70 lbs. 15 oz (32.17 kg)
7 section divider valve assembly	80 lbs. 4 oz (36.40 kg)
8 section divider valve assembly	89 lbs. 9 oz (40.62 kg)
9 section divider valve assembly	98 lbs. 14 oz (44.84 kg)
10 section divider valve assembly	108 lbs. 3 oz (49.07 kg)
11 section divider valve assembly	117 lbs. 8 oz (53.40 kg)
Torque Ratings	
Tie Rod Nut	12 ft. lbs (16.3 N.m)
Enclosure Plug	15 ft. lbs (20.3 N.m)
Outlet Port Plug	6-8 ft. lbs (8.1-10.9 N.m)
Valve Section Mounting Screw	12-13 ft. lbs. (16.3-17.6 N.m)

\*See Cycle Rate and Flow Guidelines Table, page 44.

**Dimensions (inches / mm)**

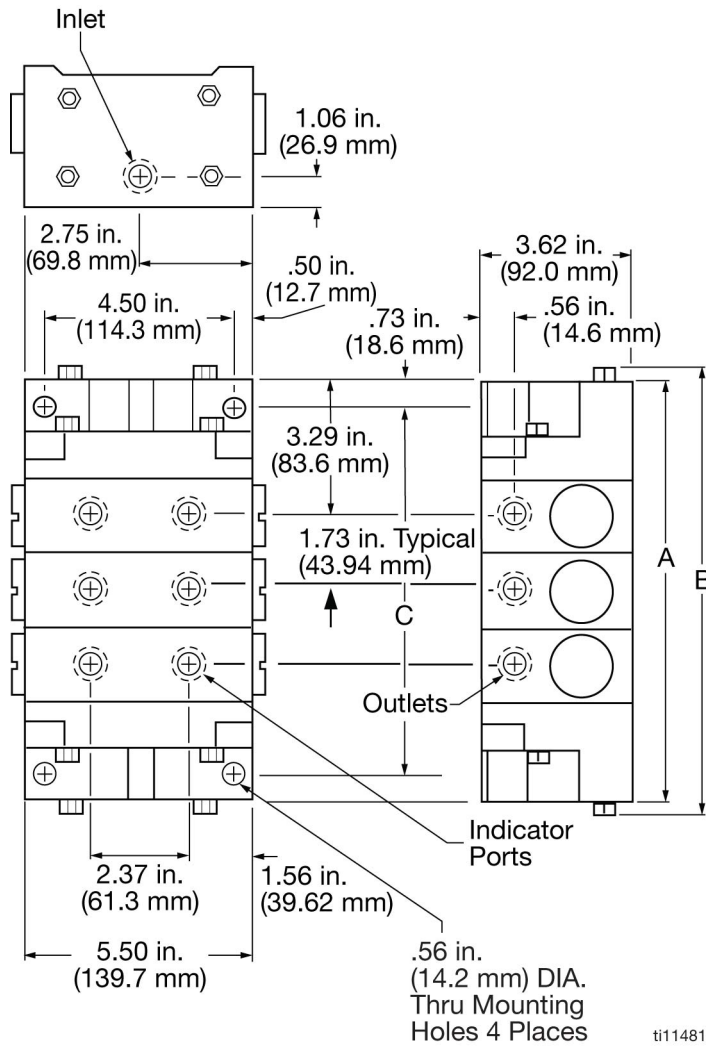

ti11481c

Divider Valve	Dimension A		Dimension B		Dimension C	
	inch	mm	inch	mm	inch	mm
MGO - 3	10.04	255.1	11.00	279.4	8.58	217.8
MGO - 4	11.78	299.1	12.75	323.8	10.31	261.9
MGO - 5	13.51	343.2	14.50	368.3	12.05	305.9
MGO - 6	15.25	387.3	16.25	412.7	13.78	350.4
MGO - 7	16.98	431.2	18.00	467.2	15.51	394.0
MGO - 8	18.71	467.8	19.75	501.6	17.25	438.0
MGO - 9	20.45	519.3	21.50	546.1	18.98	482.1
MGO - 10	22.18	563.4	23.25	590.5	20.72	526.1
MGO - 11	23.91	607.3	25.00	635.0	22.4	570.2



Parts

Ref	Part No.	Description
1	562570	VALVE, MGO, assembly 150S SAE
	562571	VALVE, MGO, assembly 300S SAE
	562572	VALVE, MGO, assembly 450S SAE
	562573	VALVE, MGO, assembly 600S SAE
	562574	VALVE, MGO, assembly 150T SAE
	562575	VALVE, MGO, assembly 300TS SAE
	562576	VALVE, MGO, assembly 450T SAE
	562577	VALVE, MGO, assembly 600T SAE
	562578	VALVE, MGO, assembly 150S SAE IND
	562579	VALVE, MGO, assembly 300S SAE IND
	562580	VALVE, MGO, assembly 450S SAE IND
	562581	VALVE, MGO, assembly 600S SAE IND
	562582	VALVE, MGO, assembly 150T SAE IND
	562583	VALVE, MGO, assembly 300T SAE IND
	562584	VALVE, MGO, assembly 450T SAE IND
	562585	VALVE, MGO, assembly 600T SAE IND
2	563277	INLET,
3	563278	END
4	560591	ROD, tie, short MGO 3 (2 required)
	560592	ROD, tie, short MGO 4 (2 required)
	560593	ROD, tie, short MGO 5 (2 required)
	560594	ROD, tie, short MGO 6 (2 required)
	560595	ROD, tie, short MGO 7 (2 required)
	560596	ROD, tie, short MGO 8 (2 required)
	560597	ROD, tie, short MGO 9 (2 required)
	560598	ROD, tie, short MGO 10 (2 required)
5	560600	ROD, tie, long MGO 3 (2 required)
	560601	ROD, tie, long MGO 4 (2 required)
	560602	ROD, tie, long MGO 5 (2 required)
	560603	ROD, tie, long MGO 6 (2 required)
	15U857	ROD, tie, long MGO 7 (2 required)
	560604	ROD, tie, long MGO 8 (2 required)
	560605	ROD, tie, long MGO 9 (2 required)
	560606	ROD, tie, long MGO 10 (2 required)
6	557494	NUT, tie rod 3/8 - 24 lock (8 required)

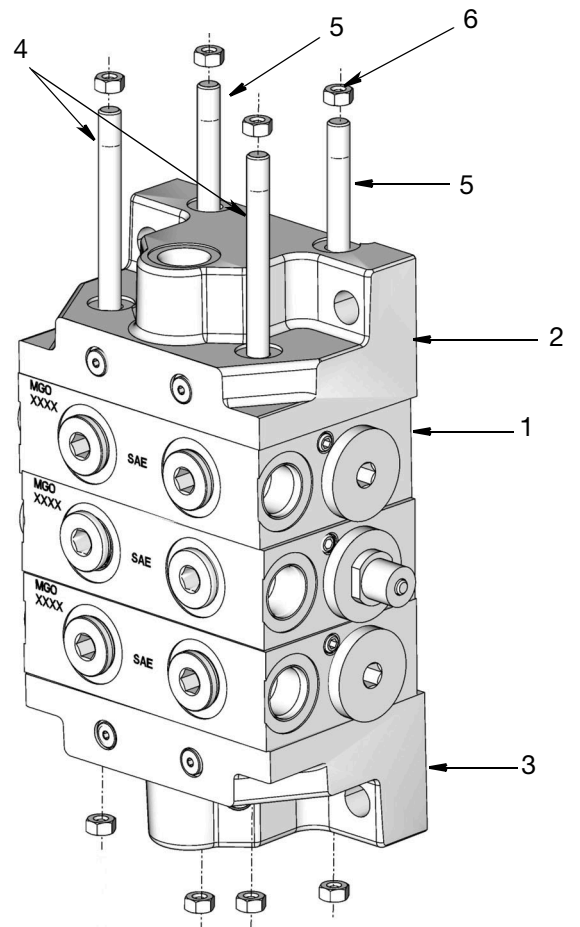

# MX Series

## Technical Specifications

Material	Plated Steel
Pressure (max)	3,000 psi (21 MPa, 206.8 bar)
Lubricant	Oil or grease
Maximum Operating Temperature	200°F (93°C)
Maximum Cycle Rate With Cycle Pin	60 CPM
Maximum Cycle Rate Without Cycle Pin	200 CPM
Net Weight (approx.)	
3 section divider valve assembly	21-lb. 6 oz (9.69 kg)
4 section divider valve assembly	25 lbs. 10 oz (11.62 kg)
5 section divider valve assembly	29 lbs. 14 oz (13.55 kg)
6 section divider valve assembly	34 lbs. 2 oz (15.47 kg)
7 section divider valve assembly	38 lbs. 6 oz (17.40 kg)
8 section divider valve assembly	42 lbs. 12 oz (19.39 kg)
9 section divider valve assembly	47 lbs. 2 oz (21.37 kg)
10 section divider valve assembly	51 lbs. 8 oz (23.26 kg)
Torque Ratings	
Tie Rod Nut	23 ft. lbs (31.2 N.m)
Enclosure Plug	46 ft. lbs (62.4 N.m)
Outlet Port Plugs	18 ft. lbs. (24.4 N.m)

**Dimensions (inches / mm)**

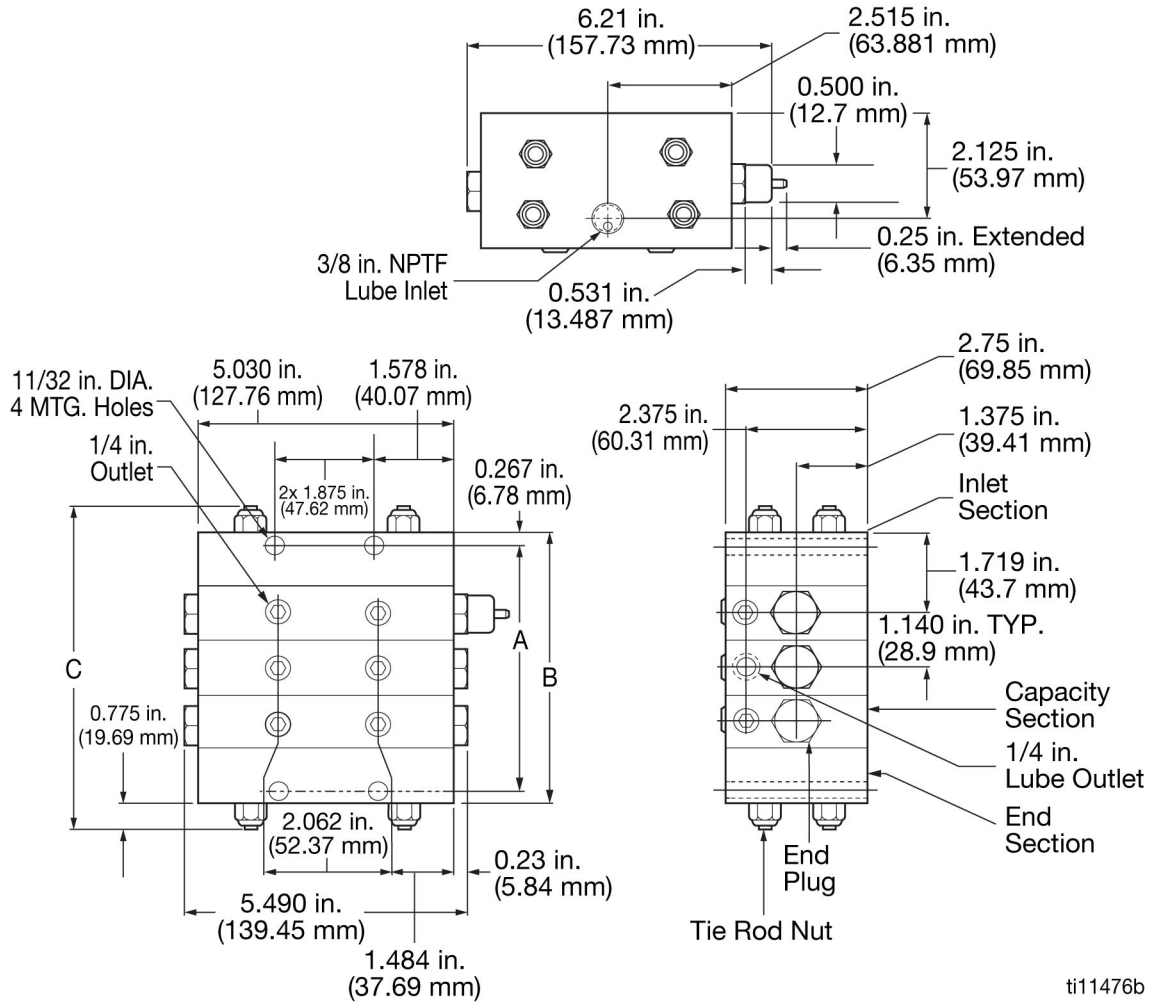

ti11476b

Number of Sections	Dimension A		Dimension B		Dimension C	
	inch	mm	inch	mm	inch	mm
3	5.08	128.9	5.61	142.5	6.63	168.3
4	6.2	157.5	6.74	171.1	7.75	196.9
5	7.33	186.1	7.86	199.6	8.88	225.4
6	8.45	214.7	8.99	228.2	10.00	254.0
7	9.58	243.2	10.11	256.8	11.13	282.6
8	10.7	271.8	11.24	285.4	12.25	311.2
9	11.83	300.4	12.36	313.9	13.38	339.7
10	12.95	329	13.49	342.5	14.50	368.3

Parts

Ref	Part No.	Description
1*	562514	VALVE, MX assembly 25S
	562515	VALVE, MX assembly 25T
	562516	VALVE, MX assembly 50S
	562517	VALVE, MX assembly 50T
	562538	VALVE, MX assembly 75S
	562539	VALVE, MX assembly 75T
	562540	VALVE, MX assembly 100S
	562541	VALVE, MX assembly 100T
	562542	VALVE, MX assembly 125S
	562543	VALVE, MX assembly 125T
	562545	VALVE, MX assembly 150S
	562546	VALVE, MX assembly 150T
	562528	VALVE, MX assembly 50S IND LH
	562518	VALVE, MX assembly 50S IND RH
	562533	VALVE, MX assembly 50T IND LH
	562523	VALVE, MX assembly 50T IND RH
	562529	VALVE, MX assembly 75S IND LH
	562519	VALVE, MX assembly 75S IND RH
	562534	VALVE, MX assembly 75T IND LH
	562524	VALVE, MX assembly 75T IND RH
	562530	VALVE, MX assembly 100S IND LH
	562520	VALVE, MX assembly 100S IND RH
	562569	VALVE, MX assembly 100T IND LH
	562525	VALVE, MX assembly 100T IND RH
	562531	VALVE, MX assembly 125S IND LH
	562521	VALVE, MX assembly 125S IND RH
	562535	VALVE, MX assembly 125T IND LH
	562526	VALVE, MX assembly 125T IND RH
	562532	VALVE, MX assembly 150S IND LH
	562522	VALVE, MX assembly 150S IND RH
	562536	VALVE, MX assembly 150T IND LH
	562527	VALVE, MX assembly 150T IND RH
2*	560620	BLOCK, inlet
3*	563287	BLOCK, end
4	557488	ROD, tie, MX 3 (4 required)
	557489	ROD, tie, MX 4 (4 required)
	557490	ROD, tie, MX 5 (4 required)
	557491	ROD, tie, MX 6 (4 required)
	557492	ROD, MX 7 (4 required)
	557493	ROD, tie, MX 8 (4 required)
	560576	ROD, tie, MX 9 (4 required)
	560577	ROD, tie, MX 10 (4 required)
5	557494	NUT, tie rod 3/8 - 24 lock (8 required)
6	557509	GASKET feeder, MX

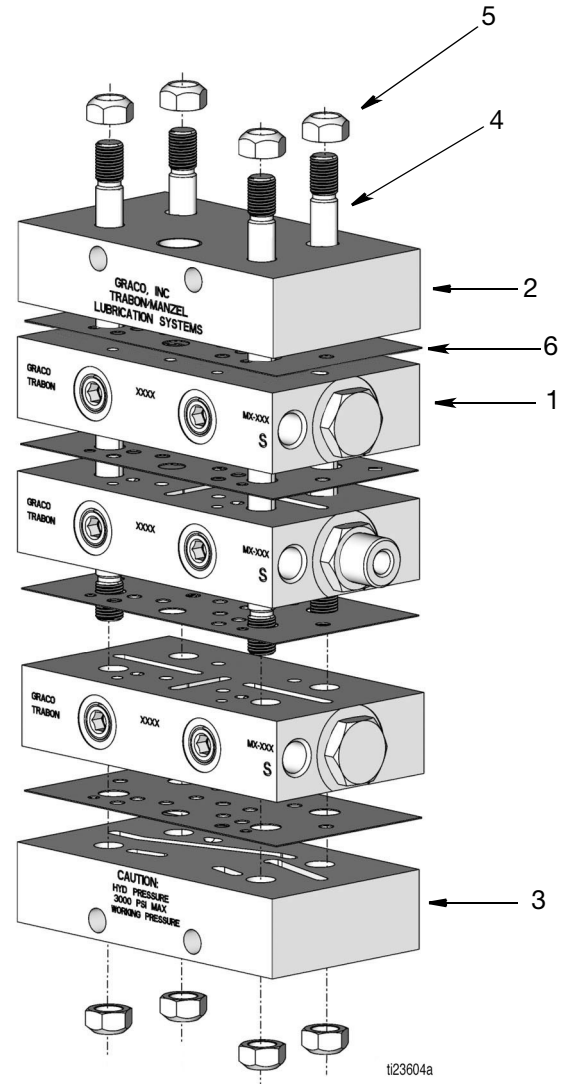

\*Component shipped with gasket

## Accessories

### Tube Clips

Clips are plated and provided with 17/64 in. (6.75 mm) mounting holes.

Part No.	Description
557324	Holds 1 - 1/4 in. (6.35 mm) OD tube
558711	Holds 1 - 3/8 in. (9.52 mm) OD tube
558710	Holds 3 - 1/4 in. (6.35 mm) OD tube

### Mounting Bars

Part No.	Description
560920	MSP, 1/2 in.(12.7 mm) thick, 1/4-20 thread
561101	MJ, 1/2 in. (12.7 mm) thick, 10-24 thread
561102	MX and MXP, 1/2 in. (12.7 mm) thick, 5/16-18 threads, two sets of mounting holes
563465	KIT, mounting bar, includes 2 mounting bars, 4 screws, washers and lock washers

### Mounting Brackets

All mounting brackets include screws, lock washers and nuts.

Part No.	Description
563435	MSP and MH, M-3 and M-4, 1/8 in. (3.175 mm) thick, top mounting.
563436	MSP and MH, M5 and M-6, 1/8 in. (3.175 mm) thick, top mounting
563437	MSP and MH, M7 and M-8, 1/8 in. (3.175 mm) thick, top mounting
563438	MSP and MH, M-3 and M-4, 1/8 in. (3.175 mm) thick, side mounting.
563439	MSP and MH, M5 and M-6, 1/8 in. (3.175 mm) thick, side mounting
563440	MSP and MH, M7 and M-8, 1/8 in. (3.175 mm) thick, side mounting

## Performance Indicators

Performance indicators are pressure sensitive devices that signal a fault when pressure in a series progressive lubricating system builds excessively. A fault is identified by extending a pin or by releasing lubricant to the atmosphere.

### Reset Indicator with Memory

Reset Indicators stop lube system operation when a fault occurs. They can be used in either master or secondary divider valves. A fault is indicated by a pin extending through the opening in the cap and is manually reset.

Pressure PSI (MPa, bar)	Description					
	1/8 NPTF MJ, MH, MS, MXP	1/8 NPSF w/O-Ring MH, MS, MXP	Nickel Plated 1/8 NPTF MJ, MH, MS, MXP	1/4 in. NPTF MX Only	7/8 in. SAE w/O-Ring MGO	1/8 NPSF w/O-Ring MSP SST
<b>250 (2, 17)</b>	563231	563252	NA	563239	NA	NA
<b>500 (3, 34)</b>	563232	563253	563246	563240	NA	NA
<b>750 (5, 51)</b>	563233	563254	NA	563241	NA	NA
<b>1000 (7, 69)</b>	563234	563255	563247	563242	NA	24B495
<b>1500 (10, 103)</b>	563235	563256	563248	563243	564200	24B496
<b>2000 (14, 138)</b>	563236	563257	NA	563244	NA	24N373
<b>2500 (17, 172)</b>	563237	563258	563249	563245	NA	NA
<b>3000 (21, 207)</b>	NA	563261	NA	NA	NA	NA
<b>5000 (34, 344)</b>	NA	563262	NA	NA	NA	NA

## Automatic Relief Indicator

An automatic relief indicator pinpoints lube line blockage but allows the lube system to continue supplying lubricant to points that are not blocked. They are used primarily in secondary divider valves. The excessive pressure created by line blockage moves a piston, enabling the lubricant to escape through a vent. When pressure is relieved the spring resets the piston. Because these indicators permit the lube system to continue operating when a lube point is blocked, a separate pressure switch connected to an audible or visual alarm should be used to warn of high pressure.

Pressure PSI (MPa, bar)	Color*	Description			
		1/8 NPTF MJ, MH, MSP, MXP	1/8 NPSF w/O-Ring MH, MSP, MXP	1/4 NPTF MX Only	1/8 npt w/O-Ring MSP SST
750 (5, 51) ± 20%	Blue	563163	563170	563156	24N945
1000 (7, 69) ± 20%	Green	563164	563171	563157	NA
1250 (9, 86) ± 20%	Yellow	563165	563172	NA	NA
1500 (10, 103) ± 20%	Red	563166	563173	563158	24N948
2000 (14, 138) ± 20%	Orange	563167	563174	563159	24N949
2500 (17, 172) ± 20%	Aluminum	563168	563175	563160	24N951
3000 (34, 344) ± 24%	Purple	563169	563176	563161	24N952

\* Color provided for reference only to aid in selection of replacement indicator. Indicators used to be identified by the color of the spring retainer located in the end of the indicator.

## Rupture Indicator - MH Divider Valves Only

Rupture Indicators are only used on MH divider valve applications where lube system pressures exceed 2500 psi (17 MPa, 172 bar). High pressure from the lube line blockage causes a disc to rupture. The lubricant then forces an indicator pin to extend, showing the blockage. The high pressure backs up through the system and trips a switch that turns the system off. When the fault is corrected, the disc must be replaced and the pin reset manually.

Pressure PSI (MPa, bar)	Description			
	1/8 - 27 NPTF	1/8 - 27 NPSF w/O-Ring	Disc Color	Replacement Disc 3/8 in. Diameter
2800 (19, 193) ± 20%	563228	563229	Green	557422
3700 (26, 255) ± 20%	563220	563221	Yellow	557423
4600 (32, 317) ± 20%	564355	563222	Red	557424
5500 (38, 379) ± 20%	563223	563224	Orange	557425
6400 (44, 441) ± 20%	563225	563226	Pink	557427
7300 (50, 503) ± 20%	563227	NA	Blue	557428
8200 (57, 565) ± 20%	NA	NA	Purple	557429

## Rupture-to-Atmosphere Indicator

Rupture-to-Atmosphere Indicators are standard on all Graco pumps. When the pressure reaches a predetermined pressure setting, the pressure disc ruptures, venting lubricant into the atmosphere and relieving pressure.

Pressure PSI* (MPa, Bar)	Description			
	Complete Assembly	Replacement	Disc Color	Blowout Disc
	<b>1/4 NPTF Fittings</b>	<b>11/16 in. Diameter</b>		<b>Quantity = 6</b>
<b>900 (6.2, 62)</b>	NA	557431	Black	NA
<b>1450 (10, 100)</b>	563179	557433	Yellow	563962
<b>1750 (12, 121)</b>	563182	557434	Red	563963
<b>2050 (14, 141)</b>	563183	557435	Orange	563964
<b>2350 (16, 162)</b>	563184	557436	Aluminum	563965
<b>2650 (18, 183)</b>	NA	557437	Pink	NA
<b>2950 (20, 203)</b>	563185	557438	Blue	563966
<b>3250 (22, 224)</b>	NA	557439	Purple	NA
	<b>1/8 NPTF Fittings</b>	<b>3/8 in. Diameter</b>		<b>Quantity = 25</b>
<b>900 (6.2, 62)</b>	NA	555788	Black	563952
<b>1450 (10, 100)</b>	NA	557423	Yellow	563954
<b>1750 (12, 121)</b>	564059	557424	Red	563955
<b>2050 (14, 141)</b>	NA	557425	Orange	563956
<b>2350 (16, 162)</b>	563191	557426	Aluminum	563957
<b>2650 (18, 183)</b>	NA	557427	Pink	563958
<b>2950 (20, 203)</b>	563192	557428	Blue	563959
<b>3250 (22, 224)</b>	563193	557429	Purple	563960
<b>5000 (34, 344)</b>	563194	557430	Brown	563961
	<b>High Pressure 1/8 NPTF Fittings</b>	<b>3/8 in. Diameter</b>		<b>Quantity = 25</b>
<b>3700 (26, 255)</b>	564476	557423	Yellow	563954
<b>4600 (32, 317)</b>	563216	557424	Red	563955
<b>5500 (38, 379)</b>	563217	557425	Orange	563956
<b>6400 (44, 441)</b>	563218	557427	Pink	563958
<b>7300 (50, 503)</b>	563219	557428	Blue	563959
<b>8200 (57, 565)</b>	NA	557429	Purple	563960
<b>9500 (66, 655)</b>	NA	NA	Gray	NA

## Rupture-to-Atmosphere Indicator with Spud Assembly

A Spud Assembly is available to return vented lubricant to the reservoir by way of a tube. A high pressure switch provides an audible or visual warning alarm that height system pressure has occurred.

Pressure PSI* (MPa, bar)	Description		
	Complete Assembly	Replacement	Disc Color
<b>1450 (10, 100)</b>	563186	557433	Yellow
<b>1750 (12,121)</b>	563187	557434	Red
<b>2350 (16, 162)</b>	563188	557436	Aluminum

\*All pressures have a tolerance of + 500 psi (3.4 MPa, 34.5 bar)

## Rupture Discs

All discs have a 11/16 in. diameter.

Pressure PSI* (MPa, bar)	Description		Quantity 6/package
	Single Disc	Disc Color	
<b>900 (6.2, 62)</b>	557431	Black	NA
<b>1175 (8.1, 81)</b>	557432	Green	NA
<b>1450 (10, 100)</b>	557433	Yellow	563962
<b>1750 (12, 121)</b>	557434	Red	563963
<b>2050 (14, 141)</b>	557435	Orange	563964
<b>2350 (16, 162)</b>	557436	Aluminum	563965
<b>2650 (18, 183)</b>	557437	Pink	NA
<b>2950 (20, 203)</b>	557438	Blue	563966
<b>3250 (22, 224)</b>	557439	Purple	NA

\*All pressures have a tolerance of + 500 psi (3.4 MPa, 34.5 bar)

## Singling and Crossporting Bar Assemblies

Singling Kits externally convert a “T” (Twin Outlet) section to an “S” (Single Outlet) section.

Crossporting Kits externally combine the output of two (2) adjacent sections.

Part Numbers								
Divider	Single Kit	Right Side	Left Side	4Rside	Gasket Upper Seal (Bar Type)	Gasket Lower Seal (Bar Type)	90 Duro Fluoroelastomer O-Ring (plate Type)	Valve Block Mounting Screw-Long
<b>MJ</b>	562915	562914	562914	NA	557359	557403	NA	NA
<b>MHH</b>	563469	563469	563470	563471	NA	NA	122276	556514
<b>MSP</b>	563469	563469	563470	563471	NA	NA	122276	556514
<b>MS (Nickel)</b>	NA	NA	NA	NA	NA	NA	NA	NA
<b>MX</b>	562916	562917	562917	NA	557511	557512	NA	NA
<b>MXP</b>	NA	563525	563524	563526	NA	NA	115010	555601
<b>MXP (Nickel)</b>	NA	NA	NA	NA	NA	NA	NA	NA
<b>MGO</b>	NA	NA	NA	NA	NA	NA	NA	NA

## Cycle Indicators

Cycle Indicators provide a means of visually monitoring lube flow through the system.

The pin type cycles in and out when lubricant is flowing. Movement of the pin is caused by the piston (the two are attached) so that when the piston moves the indicator pin in and out once, the entire divider valve has cycled.

Valve Series	O-Ring Sealed
<b>MS/MHH</b>	563251
<b>MX/MXP</b>	563260
<b>MGO</b>	NA



## Cycle Counters - Part No. 563444

The cycle counter assures that the lubricant is flowing through the system. Every count indicates one complete cycle of the divider valve. Visual inspection and recording of counts provides a constant check on the performance of the lubricant system and the pump. The cycle counter can be used on any MJ, MS, MH, MX and MXP divider valve assembly.

## Cycle Switches

The function of a cycle switch is to electrically assure that the lubricant is flowing through the system. Actuated by a cycle pin, the cycle switch can be wired to various controls.

**NOTE:** The cycle switch must be attached to a section that is equipped with a cycle indicator pin.

Part Numbers						
Series Flo Divider Valves	MJ	MS/MH	MS (Nickel)	MX	MXP	MGO
Cycle Switch and Bracket Assembly SPDT	563272	563272	563272	563272	563272	563269
	<i>Electrical Ratings: 15 amps at 125, 250 and 480 VAC; 1/2 amp at 125 VDC, 1/4 amp at 250 VDC, 6.0 amp at 24 VDC Non-Inductive</i>					
Replacement Switch	557781	557781	557781	557781	557781	557781
	564357	564357	564537	564357	564537	NA
Cycle Switch and Bracket Assembly DPDT	<i>Electrical Ratings: 10 amps at 125 or 250 VAC; 0.3 amp at 125 VDC or 0.15 amp at 250 VDC</i>					
Replacement Switch	NA	NA	NA	NA	NA	NA
Replacement Bracket for either SPDT or DPDT Switch Assembly	557546	557546	557546	557546	557546	560573
Moisture Resistant Cycle Switch with 6-foot Cable and Bracket Assembly SPDT	563273	563273	563273	563273	563273	NA
	<i>Electrical Ratings: 5 amps at 125 or 250 VAC; Wire Code for Moisture Resistant Switch: BK (Com), Red (N.C), WH (N.O.), GN (Ground)</i>					
Replacement Switch with 6-foot Cable	557782	557782	557782	557782	557782	NA

## Proximity Cycle Switches

The proximity cycle switches are magnetically operated single throw switches that sense the movement of the divider valve piston when it is cycling. Each proximity cycle switch provides a signal that is used to monitor the system. There are three (3) different types of switches available.

**Solid State Proximity Switch:** Recommended for all applications including press and other demanding applications. No moving parts. Capable of operation at cycle rates above 200 cycles per minute. Rated for 50 g shock and 20 g vibration.

**Reed Type Proximity Switch:** Can be used with oil applications only for MS, MH and MGO divider valves at pressures up to 518 bar (7500 psi, 52 MPa) at cycle rates under 60 cycles per minute.

**Field Sensitive Magnetic Proximity Switch:** Dry contact, ceramic magnet operated switch. Used at pressures that do not exceed 242 bar (3500 psi, 24 MPa) at cycle rates up to 200 cycles per minute. Used in MS, MH, MX, MXP and MGO divider valves. An explosion proof version for MS/MH divider valves is available.

**Magnetic Operated Proximity Switch:** Not limited to valve size. Miniature snap-action switch is tripped by attraction of internal magnet to the moving divider piston. Can be used at pressures up to 518 bar (7500 psi) at cycle rates that do not exceed 150 cycles per minute.

Description	No. of Pins	Type Seal	Part Number						
			MS	MH	MX	MXP	MGO	MJ/MD	CSP
Unattached Reed Type (oil only) 10mA @ 120VAC 24 mA @ 24VDC 10,000,000 Cycle Life	1/2 npt with Leads (Explosion Proof)	O-Ring	563427	563427	NA	NA	NA	NA	NA
Field Sensitive Magnetic Type 3-pin and 5-pin (AC only) 2A @ 120/240 VAC 4-pin (DC only) 0.1A @ 28VDC 150,000,000 Cycle Life 50,000,000 in L15600	3	O-Ring	557741	557741	563476	563476	563970	NA	NA
		Gasket*	NA	NA	NA	NA	NA	NA	NA
	5	O-Ring	557746	557746	564399	564399	NA	NA	NA
		Gasket*	NA	NA	NA	NA	NA	NA	NA
	4	O-Ring	557747	557747	564403	564403	563495	NA	NA
Magnetic Type with LED's 5A @ 24 VDC 10,000,000 Cycle Life	3	O-Ring	563478	563478	NA	NA	NA	NA	NA
	5	O-Ring	563477	563477	NA	NA	NA	NA	NA
Magnetic Type 5A @ 24VDC 5A @ 120/240 VAC 10,000,000 Cycle Life	3	Gasket*	NA	NA	563486	563486	NA	NA	NA
	5	O-Ring	563484	563484	564400	564400	NA	NA	NA
	Pigtail Lead (Explosion Proof)	O-Ring	563485	563485	NA	NA	NA	NA	NA
Field Sensitive Magnetic Type 25 mA @ 24VDC M12 x 1, 4-pin (DC only) 10,000,000, cycle life	4	O-Ring	563500	563501	NA	NA	NA	NA	NA
Solid State Type 500mA @ 32VDC 200,000,000 Cycle Life	4†	Gasket	NA	NA	NA	NA	NA	17M380	NA
	4†	O-Ring	17L983	17L983	17L880	17L880	17L881	NA	17L879

\*Consult your distributor for availability.

† M12 connection. Cable adapters for Brad Harrison® connections. Used for other proximity switches. Are available for retrofit applications.

Brand names and Trademarks are used for identification purposes and are trademarks of their respective owners.

## Proximity Switch Connection Cables

Connection Cables for:					
3-Pin Proximity Switch			5-Pin Proximity Switch		
Connector	Length - ft (m)	Part No.	Connector	Length - ft (m)	Part No.
Straight	6 (1.83)	558021	Straight	6 (1.83)	558023
Straight	12 (3.66)	558022	Straight	12 (3.66)	558024
NA	NA	NA	90°	6 (1.83)	558965
4-Pin Proximity Switch					
Straight	7 (2.13)	568738	NA	NA	NA

## Base Section Sub Assemblies

Part No.	Description
24N382	PLATE, base, MSP, NPTF, 3 sect, SS
24N383	PLATE, base, MSP, NPTF, 4 sect, SS
24N384	PLATE, base, MSP, NPTF, 5 sect, SS
24N385	PLATE, base, MSP, NPTF, 6 sect, SS
24N386	PLATE, base, MSP, NPTF, 7 sect, SS
24N387	PLATE, base, MSP, NPTF, 8 sect, SS
24N388	PLATE, base, MSP, BSPP, 3 sect, SS
24N389	PLATE, base, MSP, BSPP, 4 sect, SS
24N390	PLATE, base, MSP, BSPP, 5 sect, SS
24N391	PLATE, base, MSP, BSPP, 6 sect, SS
24N392	PLATE, base, MSP, BSPP, 7 sect, SS
24N393	PLATE, base, MSP, BSPP, 8 sect, SS

## MSP Shunt Inlet and Zero-Leak Shut-Off Inlet

**Shunt Inlet:** A three-way valve (electronic or pneumatic). Allows lubricant to enter the divider valve, bypasses the lubricant to another divider valve, or diverts lubricant back into the tank. Replaces standard inlet or mount in-line with remote manifold kit.

**Zero-Leak Shut-Off Inlet:** A two-way valve used with either continuous or intermittent pressurized header systems. Replaces a standard inlet section or mounts in-line with a remote manifold kit.

### Installation on MSP Valve Assembly:

Reference FIG. 16 and FIG. 18 for this section.

- Loosed and remove the three nuts at the bottom of the valve assembly.
- Slide the inlet block from the intermediate blocks.
- Loosed and remove the three tie rods from the inlet block.

- Install three tie rods into shunt or shut-off inlet then torque to 5 - 8 ft lbs. (6.8 - 10.8 N•m).
- Slide the rods into the intermediate block.
- Verify that the o-rings are in position.
- Install the three nuts to the bottom of the valve assembly then torque to 5 - 8 ft lbs. (6.8 - 10.8 N•m).

### Installation on Remote Manifold

Please refer to FIG. 17 to FIG. 19 for this section.

- Install supplied o-ring into the remote manifold face seal gland.
- Align the remote manifold with the shunt or shut-off inlet.
- Install the two screws through the manifold then torque to 8 - 9 ft lbs. (10.8 -12.2 N•m).

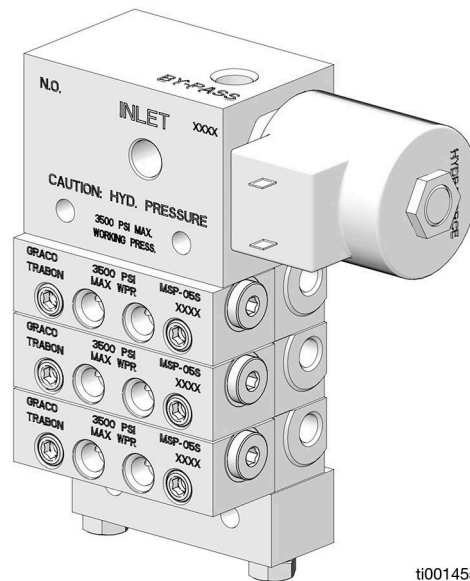
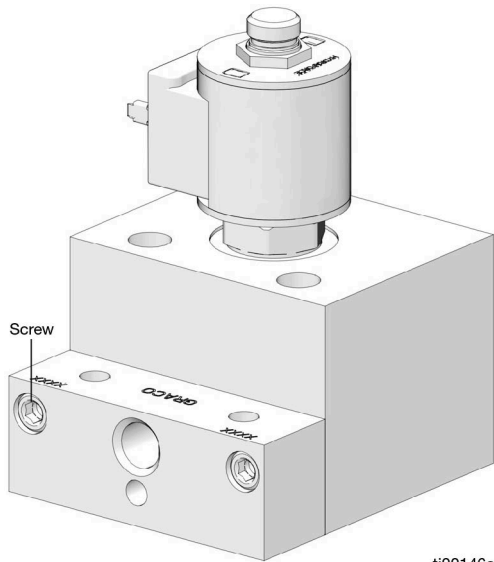

FIG. 16

ti00145a



ti00146a

FIG. 17

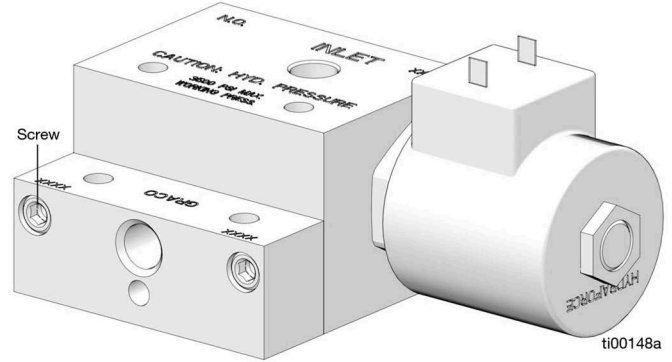

ti00148a

FIG. 19

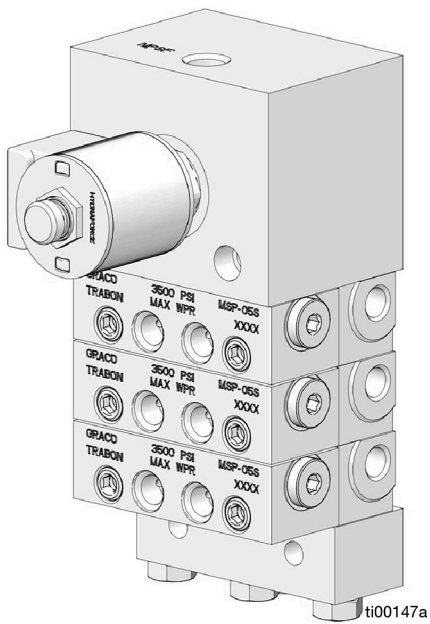

ti00147a

FIG. 18

Component	Description	Part No.	Connection Type	Size	Maximum Internal Leakage	Coil Parameters
Shunt Inlet Section, MSP	115 VAC, DIN 43650 connection (NO)	25B534	NPSF	1/4 in.	8 in <sup>3</sup> /min 131 cm <sup>3</sup> /min	Coil resistance: 568 ohm Initial current draw: 0.17A Initial power consumption: 20W
		25U054	SAE	9/16-18		
	115 VAC, DIN 43650 connection (NC)	25B535	NPSF	1/4 in.		
		25U053	SAE	9/16-18		
	24 VDC, DIN 43650 connection (NO)	25B515	NPSF	1/4 in.		Coil resistance: 28.5 ohm Initial current draw: 0.84A Initial power consumption: 20.21W
		25U041	BSPP	1/4 in.		
		25U052	SAE	9/16-18		
	24 VDC, DIN 43650 connection (NC)	25B514	NPSF	1/4 in.		
25U040		BSPP	1/4 in.			
25U051		SAE	9/16-18			
Pneumatic Shunt Inlet, 1/8 NPSF air inlet	563456	NPSF	1/4 in.	--	N/A	
Zero-Leak Shut-Off Inlet Valve Section	115 VAC, DIN 43650 connection	20A900	NPSF	1/4 in.	3 drops/min.	Coil resistance: 765.5 ohm Initial current draw: 0.14A Initial power consumption: 8.5W
		20A901	SAE	9/16-18		
	24 VDC, DIN 43650 connection	20A903	NPSF	1/4 in.		
		20A902	BSPP	1/4 in.		
		20A904	SAE	9/16-18		
Inlet restricter with 90 micron last chance filter	563074	N/A	N/A	N/A	N/A	
Remote Mount Manifold Kit for Shunt or Zero-Leak Shut-Off Section	Includes outlet manifold, o-ring, and screws	563461	NPSF	1/4 in.	N/A	N/A
Connection Cable	DIN connector with 15 ft cable	16U790				
	Filed installable DIN connector, no wire	132924				
	Adapter cable (3-pin Brad Harrison to DIN). Use for retrofits. See Shunt Inlet Valve/Zero-Leak Shut-Off Inlet Adapter Wiring Harness Kit.	25T585				
Shunt Replacement Parts	115 VAC replacement solenoid valve*	20A339				
	24 VDC replacement solenoid valve*	20A081				
	115 VAC replacement coil (115 VAC BH connectors only)	557214**				
Zero-Leak Replacement Parts	115 VAC replacement solenoid valve*	20A586				
	24 VDC replacement solenoid valve*	20A585				
	Zero Leak valve repair kit	563993***				

\*The new replacement solenoid valves will not work in the old-style shunt and zero-leak shut-off valves. For an old-style solenoid valve, order a new shunt valve.

\*\*Only works with parts 563452, 560953, 563453, and 563463.

\*\*\*Only works with parts 563460, 563464, 563486, and 563467.

# Maximum Cycle Rate and Flow Guidelines

## MGO

Smallest Piston Assembly	Number of Sections								
	3	4	5	6	7	8	9	10	11
600	185	140	110	90	80	70	60	55	50
450	185	135	110	90	75	65	60	50	50
300	180	130	100	80	70	60	55	50	45
150	180	125	100	80	65	55	50	45	40

## MXP

Smallest Piston Assembly	Number of Sections							
	3	4	5	6	7	8	9	10
150	200	200	200	200	200	200	180	165
125	200	200	200	200	200	195	175	155
100	200	200	200	200	200	185	165	150
75	200	200	200	200	200	175	155	140
50	200	200	200	200	195	165	145	130
75	200	200	200	200	165	140	125	120

# California Proposition 65

## CALIFORNIA RESIDENTS

 **WARNING:** Cancer and reproductive harm – [www.P65warnings.ca.gov](http://www.P65warnings.ca.gov).

# Graco Standard Warranty

Graco warrants all equipment referenced in this document which is manufactured by Graco and bearing its name to be free from defects in material and workmanship on the date of sale to the original purchaser for use. With the exception of any special, extended, or limited warranty published by Graco, Graco will, for a period of twelve months from the date of sale, repair or replace any part of the equipment determined by Graco to be defective. This warranty applies only when the equipment is installed, operated and maintained in accordance with Graco's written recommendations.

This warranty does not cover, and Graco shall not be liable for general wear and tear, or any malfunction, damage or wear caused by faulty installation, misapplication, abrasion, corrosion, inadequate or improper maintenance, negligence, accident, tampering, or substitution of non-Graco component parts. Nor shall Graco be liable for malfunction, damage or wear caused by the incompatibility of Graco equipment with structures, accessories, equipment or materials not supplied by Graco, or the improper design, manufacture, installation, operation or maintenance of structures, accessories, equipment or materials not supplied by Graco.

This warranty is conditioned upon the prepaid return of the equipment claimed to be defective to an authorized Graco distributor for verification of the claimed defect. If the claimed defect is verified, Graco will repair or replace free of charge any defective parts. The equipment will be returned to the original purchaser transportation prepaid. If inspection of the equipment does not disclose any defect in material or workmanship, repairs will be made at a reasonable charge, which charges may include the costs of parts, labor, and transportation.

**THIS WARRANTY IS EXCLUSIVE, AND IS IN LIEU OF ANY OTHER WARRANTIES, EXPRESS OR IMPLIED, INCLUDING BUT NOT LIMITED TO WARRANTY OF MERCHANTABILITY OR WARRANTY OF FITNESS FOR A PARTICULAR PURPOSE.**

Graco's sole obligation and buyer's sole remedy for any breach of warranty shall be as set forth above. The buyer agrees that no other remedy (including, but not limited to, incidental or consequential damages for lost profits, lost sales, injury to person or property, or any other incidental or consequential loss) shall be available. Any action for breach of warranty must be brought within two (2) years of the date of sale.

**GRACO MAKES NO WARRANTY, AND DISCLAIMS ALL IMPLIED WARRANTIES OF MERCHANTABILITY AND FITNESS FOR A PARTICULAR PURPOSE, IN CONNECTION WITH ACCESSORIES, EQUIPMENT, MATERIALS OR COMPONENTS SOLD BUT NOT MANUFACTURED BY GRACO.** These items sold, but not manufactured by Graco (such as electric motors, switches, hose, etc.), are subject to the warranty, if any, of their manufacturer. Graco will provide purchaser with reasonable assistance in making any claim for breach of these warranties.

In no event will Graco be liable for indirect, incidental, special or consequential damages resulting from Graco supplying equipment hereunder, or the furnishing, performance, or use of any products or other goods sold hereto, whether due to a breach of contract, breach of warranty, the negligence of Graco, or otherwise.

## **FOR GRACO CANADA CUSTOMERS**

The Parties acknowledge that they have required that the present document, as well as all documents, notices and legal proceedings entered into, given or instituted pursuant hereto or relating directly or indirectly hereto, be drawn up in English. Les parties reconnaissent avoir convenu que la rédaction du présente document sera en Anglais, ainsi que tous documents, avis et procédures judiciaires exécutés, donnés ou intentés, à la suite de ou en rapport, directement ou indirectement, avec les procédures concernées.

# Graco Information

For the latest information about Graco products, visit [www.graco.com](http://www.graco.com).

For patent information, see [www.graco.com/patents](http://www.graco.com/patents).

**TO PLACE AN ORDER**, contact your Graco distributor or call to identify the nearest distributor.

**Phone:** 612-623-6928 or **Toll Free:** 1-800-533-9655, **Fax:** 612-378-3590

*All written and visual data contained in this document reflects the latest product information available at the time of publication. Graco reserves the right to make changes at any time without notice.*

*For patent information, see [www.graco.com/patents](http://www.graco.com/patents).*

Original instructions. This manual contains English. MM 312497

**Graco Headquarters:** Minneapolis

**International Offices:** Belgium, China, Japan, Korea

**GRACO INC. AND SUBSIDIARIES • P.O. BOX 1441 • MINNEAPOLIS MN 55440-1441 • USA**

**Copyright 2009, Graco Inc. All Graco manufacturing locations are registered to ISO 9001.**

[www.graco.com](http://www.graco.com)

Revision ZAE, January 2024