

Merkur[®] Non-Heated Spray Packages

312797ZAD

EN

For high-performance finishing and coating applications in hazardous or non-hazardous locations. For professional use only.



Important Safety Instructions

Read all warnings and instructions in this manual.
Save these instructions.

See the charts beginning on page 6 for model information, including maximum air inlet pressures and maximum fluid working pressures.

Cart Mount

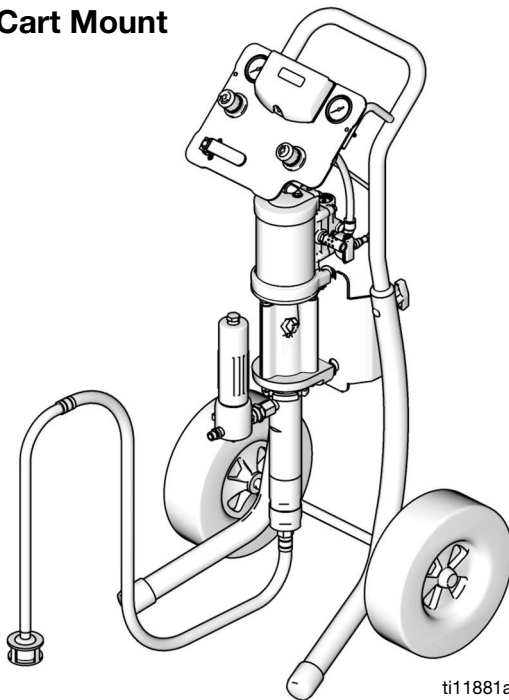

ti11881a

Wall Mount

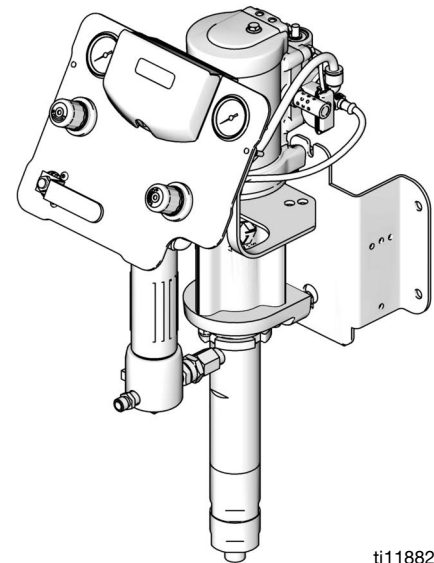

ti11882a

Contents

Related Manuals	3
Warnings	4
Models	6
Agency Approvals	7
Merkur 10:1 Packages (G10Cxx and G10Wxx)	7
Merkur 15:1 Packages (G15Wxx, G15Cxx, and G15Txx)	8
Merkur 18:1 Packages (G18Wxx and G18Cxx)	9
Merkur 23:1 Packages (G23Wxx and G23Cxx)	10
Merkur 24:1 Packages (G24Wxx and G24Cxx)	11
Merkur 28:1 Packages (G28Wxx and G28Cxx)	11
Merkur 30:1 Packages (G30Wxx, G30Cxx, and G30Txx)	12
Merkur 36:1 Packages (G36Wxx and G36Cxx)	14
Merkur 45:1 Packages (G45Wxx and G45Cxx)	15
Merkur 48:1 Packages (G48Wxx and G48Cxx)	16
Installation	17
General Information	18
Prepare the Operator	18
Prepare the Site	18
Wall Mount Packages	18
Cart Mount Packages	18
Components	19
Air Line Accessories	19
Grounding	19
Setup	20
Operation	20
Pressure Relief Procedure	20
Flush the Pump Before First Use	21
Trigger Lock	21
Wet Cup	21
Prime the Pump	21
Install the Spray Tip	22
Adjust the Atomization	22
Adjust the Spray Pattern	23
Shutdown	23

Maintenance	24
Preventive Maintenance Schedule	24
Tighten Threaded Connections	24
Flush the Pump	24
Wet Cup	24
Troubleshooting	25
DataTrak Controls and Indicators	26
DataTrak Operation	27
Setup Mode	27
Run Mode	27
Replace DataTrak Battery or Fuse	30
Parts	32
Cart Mount	32
Wall Mount	33
Stand Mount	34
G10xxx Models	35
G15xxx Models	36
G18xxx Models	37
G23xxx Models	38
G24xxx Models	39
G28xxx Models	40
G30xxx Models	41
G36xxx Models	42
G45xxx Models	43
G48xxx Models	44
Kits	45
Wall Mount Kit 24A578	45
Cart Mount Kit 289694	45
Stand Mount Kit 24A577	45
Pump and Gun Control Panel Kits	46
Pump Only Control Panel Kits	47
DataTrak	48
Hopper Kit 256410	48
Air Control Mounting Kit 24E883, Wall and Stand 48	48
5-Gallon Suction Hose Kits	48
55-Gallon Suction Hose Kits	48
PTFE Suction Hose Kits	48
Drain Valve Kit 256425	48
Reinforced PTFE V-Packing Kits	48
Guns and Hoses	49
Wall Bracket Mounting Dimensions	50
Technical Data	50
Package Weights	51
California Proposition 65	51
Graco Standard Warranty	52
Graco Information	52





Related Manuals

Manual	Description
312792	Merkur Displacement Pump
312794	Merkur Pump Assembly
312796	NXT™ Air Motor
312798	Merkur Electrostatic Packages
313255	Merkur Heated Packages
3A8099	PerformAA Spray Gun
312145	XTR™5 and XTR™7 Airless Spray Gun
307273	Fluid Outlet Filter
313541	DataTrak Module



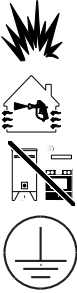

Warnings

The following warnings are for the setup, use, grounding, maintenance, and repair of this equipment. The exclamation point symbol alerts you to a general warning and the hazard symbols refer to procedure-specific risks. When these symbols appear in the body of this manual, refer back to these Warnings. Additional, product-specific warnings may be found throughout the body of this manual where applicable.

WARNING

	<p>FIRE AND EXPLOSION HAZARD</p> <p>Flammable fumes, such as solvent and paint fumes, in work area can ignite or explode. To help prevent fire and explosion:</p> <ul style="list-style-type: none"> • Use equipment only in well ventilated area. • Eliminate all ignition sources; such as pilot lights, cigarettes, portable electric lamps, and plastic drop cloths (potential static arc). • Keep work area free of debris, including solvent, rags and gasoline. • Do not plug or unplug power cords, or turn power or light switches on or off when flammable fumes are present. • Ground all equipment in the work area. See Grounding instructions. • Use only grounded hoses. • Hold gun firmly to side of grounded pail when triggering into pail. • If there is static sparking or you feel a shock, stop operation immediately. Do not use equipment until you identify and correct the problem. • Keep a working fire extinguisher in the work area.
	<p>SPECIAL CONDITIONS FOR SAFE USE</p> <p>Equipment must comply with the following conditions to avoid a hazardous condition which can cause fire or explosion.</p> <ul style="list-style-type: none"> • All label and marking material must be cleaned with a damp cloth (or equivalent). • The electronic monitoring system is required to be grounded. See Grounding instructions.
	<p>SKIN INJECTION HAZARD</p> <p>High-pressure fluid from gun, hose leaks, or ruptured components will pierce skin. This may look like just a cut, but it is a serious injury that can result in amputation. Get immediate surgical treatment.</p> <ul style="list-style-type: none"> • Do not point gun at anyone or at any part of the body. • Do not put your hand over the spray tip. • Do not stop or deflect leaks with your hand, body, glove, or rag. • Do not spray without tip guard and trigger guard installed. • Engage trigger lock when not spraying. • Follow Pressure Relief Procedure in this manual, when you stop spraying and before cleaning, checking, or servicing equipment.
	<p>PRESSURIZED EQUIPMENT HAZARD</p> <p>Fluid from the gun/dispense valve, leaks, or ruptured components can splash in the eyes or on skin and cause serious injury.</p> <ul style="list-style-type: none"> • Follow Pressure Relief Procedure in this manual, when you stop spraying and before cleaning, checking, or servicing equipment. • Tighten all fluid connections before operating the equipment. • Check hoses, tubes, and couplings daily. Replace worn or damaged parts immediately.

⚠ WARNING

	<p>EQUIPMENT MISUSE HAZARD</p> <p>Misuse can cause death or serious injury.</p> <ul style="list-style-type: none"> • Do not operate the unit when fatigued or under the influence of drugs or alcohol. • Do not exceed the maximum working pressure or temperature rating of the lowest rated system component. See Technical Data in all equipment manuals. • Use fluids and solvents that are compatible with equipment wetted parts. See Technical Data in all equipment manuals. Read fluid and solvent manufacturer's warnings. For complete information about your material, request MSDS forms from distributor or retailer. • Check equipment daily. Repair or replace worn or damaged parts immediately with genuine Graco replacement parts only. • Do not alter or modify equipment. • Use equipment only for its intended purpose. Call your Graco distributor for information. • Route hoses and cables away from traffic areas, sharp edges, moving parts, and hot surfaces. • Do not kink or over bend hoses or use hoses to pull equipment. • Keep children and animals away from work area. • Comply with all applicable safety regulations.
	<p>MOVING PARTS HAZARD</p> <p>Moving parts can pinch or amputate fingers and other body parts.</p> <ul style="list-style-type: none"> • Keep clear of moving parts. • Do not operate equipment with protective guards or covers removed. • Pressurized equipment can start without warning. Before checking, moving, or servicing equipment, follow the Pressure Relief Procedure in this manual. Disconnect power or air supply.
	<p>TOXIC FLUID OR FUMES HAZARD</p> <p>Toxic fluids or fumes can cause serious injury or death if splashed in the eyes or on skin, inhaled, or swallowed.</p> <ul style="list-style-type: none"> • Read MSDS's to know the specific hazards of the fluids you are using. • Store hazardous fluid in approved containers, and dispose of it according to applicable guidelines.
	<p>PERSONAL PROTECTIVE EQUIPMENT</p> <p>You must wear appropriate protective equipment when operating, servicing, or when in the operating area of the equipment to help protect you from serious injury, including eye injury, inhalation of toxic fumes, burns, and hearing loss. This equipment includes but is not limited to:</p> <ul style="list-style-type: none"> • Protective eyewear • Clothing and respirator as recommended by the fluid and solvent manufacturer • Gloves • Hearing protection





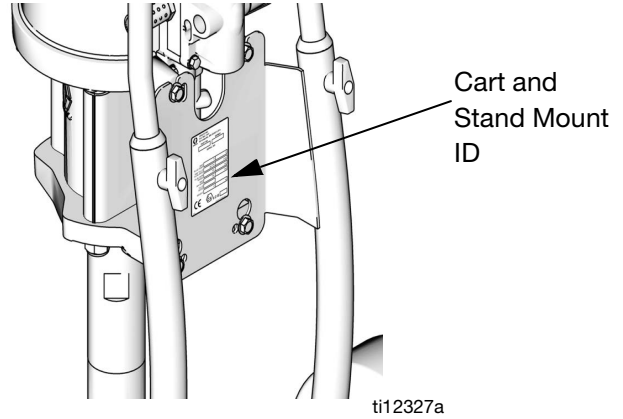
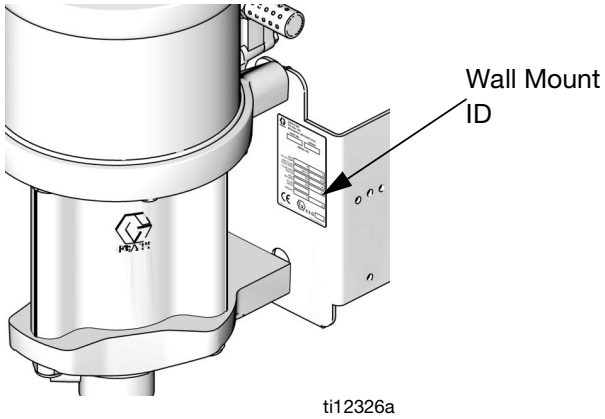

Models

Check the identification plate (ID) for the 6-digit part number of your package. Use the following matrix and tables to define the components of your package. For example, package number **G30C26** represents a Merkur package (**G**), with a 30:1 ratio pump (**30**), cart mounting (**C**), and the components shown for (**26**) in the table on page 12.



G	30		C		26
First Digit	Second and Third Digits (Ratio)		Fourth Digit (Mounting Type)		Fifth and Sixth Digit (Components Included)
G (Merkur Package)	10	10:1	C	Cart	See Tables, pages 7 to 16
	15	15:1	T	Stand	
	18	18:1	W	Wall	
	23	23:1			
	24	24:1			
	28	28:1			
	30	30:1			
	36	36:1			
	45	45:1			
48	48:1				

Agency Approvals

Merkur Packages No DataTrak Gxxxx1, Gxxxx3, Gxxxx5, Gxxxx7, Gxxxx9	   II 2 G Ex h IIB T6 Gb
Merkur Packages with DataTrak Gxxxx0, Gxxxx2, Gxxxx4, Gxxxx6, Gxxxx8	   II 2(1) G Ex h [ia Ga] IIA T3 Gb X
DataTrak™ Module	See DataTrak Kits manual 313541

Merkur 10:1 Packages (G10Cxx and G10Wxx)

Maximum Inlet Air Pressure: 100 psi (0.7 MPa, 7 bar)

Maximum Fluid Working Pressure: 1000 psi (6.9 MPa, 69 bar)

Model		Pump Assembly	Gun	Air Controls (pump and gun)	Hoses		Accessories			DataTrak	Maximum Fluid Flow Rate gpm (lpm)
Wall Mount	Cart Mount				Gun Fluid Hose	Gun Air Hose	Siphon Kit	Fluid Filter	Hopper		
G10W09	-----	W10CAS	None								1.2 (4.5)
G10W01	G10C01	W10CAS	None	✓							
G10W03	G10C03	W10CAS	None	✓			✓				
-----	G10C05	W10CAS	None	✓	✓	✓	✓				
G10W05	G10C07	W10CAS	PerformAA 15	✓	✓	✓	✓				
G10W06	G10C08	W10CBS	PerformAA 15	✓	✓	✓	✓			✓	
G10W07	G10C09	W10CAS	PerformAA 15	✓	✓	✓	✓	✓			
G10W08	G10C10	W10CBS	PerformAA 15	✓	✓	✓	✓	✓		✓	
-----	G10C11	W10CAS	PerformAA 15	✓	✓	✓			✓		
-----	G10C13	W10CAS	PerformAA 15	✓	✓	✓		✓	✓		
G10W11	G10C15	W10CAS	PerformAA 15	✓	✓	✓	✓	✓			

Merkur 15:1 Packages (G15Wxx, G15Cxx, and G15Txx)

Maximum Inlet Air Pressure 100 psi (0.7 MPa, 7 bar)

Maximum Fluid Working Pressure: 1500 psi (10.3 MPa, 103 bar)

Model			Pump Assembly	Gun	Air Controls		Hoses		Accessories			DataTrak	Maximum Fluid Flow Rate gpm (lpm)
Wall Mount	Cart Mount	Stand Mount			Pump Only	Pump and Gun	Gun Fluid Hose	Gun Air Hose	Siphon Kit	Fluid Filter	Hopper		
G15W09	-----	-----	W15AAS	None									0.40 (1.5)
G15W01	G15C01	G15T01	W15AAS	None		✓							
G15W03	G15C03	-----	W15AAS	None		✓			✓				
-----	G15C05		W15AAS	None		✓	✓	✓	✓				
G15W05	G15C07	G15T03	W15AAS	PerformAA 15		✓	✓	✓	✓				
G15W06	G15C08	G15T04	W15AAS	PerformAA 15		✓	✓	✓	✓			✓*	
G15W07	G15C09	-----	W15AAS	PerformAA 15		✓	✓	✓	✓	✓			
G15W08	G15C10	-----	W15AAS	PerformAA 15		✓	✓	✓	✓	✓		✓*	
-----	G15C11	G15T05	W15AAS	PerformAA 15		✓	✓	✓			✓		
-----	G15C12	-----	W15AAS	PerformAA 15		✓	✓	✓			✓	✓*	
-----	G15C13	-----	W15AAS	PerformAA 15		✓	✓	✓		✓	✓		
-----	G15C14	-----	W15AAS	PerformAA 15		✓	✓	✓		✓	✓	✓*	
G15W11	G15C15	-----	W15AAS	PerformAA 15, WL		✓	✓	✓	✓				
G15W13	G15C17	-----	W15AAS	PerformAA 15, WL		✓	✓	✓	✓	✓			
G15W19	-----	-----	W15BAS	None									0.8 (3.0)
G15W21	G15C21	-----	W15BAS	None		✓							
G15W23	G15C23	-----	W15BAS	None		✓			✓				
-----	G15C25	G15T11	W15BAS	None		✓	✓	✓	✓				
-----	-----	G15T12	W15BBS	None		✓	✓	✓	✓			✓	
G15W25	G15C27	G15T13	W15BAS	PerformAA 15		✓	✓	✓	✓				
G15W26	G15C28	G15T14	W15BBS	PerformAA 15		✓	✓	✓	✓			✓	
G15W27	G15C29	-----	W15BAS	PerformAA 15		✓	✓	✓	✓	✓			
G15W28	G15C30	-----	W15BBS	PerformAA 15		✓	✓	✓	✓	✓		✓	
-----	G15C31	G15T15	W15BAS	PerformAA 15		✓	✓	✓			✓		
-----	G15C33	-----	W15BAS	PerformAA 15		✓	✓	✓		✓	✓		

* DataTrak with cycle counter only, no runaway solenoid.

Model			Pump Assembly	Gun	Air Controls		Hoses			Accessories			DataTrak	Maximum Fluid Flow Rate gpm (lpm)
Wall Mount	Cart Mount	Stand Mount			Pump Only	Pump and Gun	Gun Fluid Hose	Gun Air Hose	Siphon Kit	Fluid Filter	Hopper			
G15W51	G15C75	-----	W15FAS	None									2.4 (9.0)	
G15W52	-----	-----	W15FBS	None								✓		
-----	G15C77	-----	W15FAS	None	✓									
-----	G15C78	-----	W15FBS	None	✓							✓		
G15W53	G15C79	-----	W15FAS	None	✓				✓	✓				
G15W54	G15C80	-----	W15FBS	None	✓				✓	✓		✓		
-----	G15C81	-----	W15FAS	None		✓			✓					
G15W55	G15C83	-----	W15FAS	PerformAA 15, GF		✓	✓	✓	✓	✓				
G15W56	G15C84	-----	W15FBS	PerformAA 15, GF		✓	✓	✓	✓	✓		✓		

* DataTrak with cycle counter only, no runaway solenoid.

Merkur 18:1 Packages (G18Wxx and G18Cxx)

Maximum Inlet Air Pressure: 100 psi (0.7 MPa, 7 bar)

Maximum Fluid Working Pressure: 1800 psi (12.4 MPa, 124 bar)

Model			Pump Assembly	Gun	Air Controls		Hoses			Accessories			DataTrak	Maximum Fluid Flow Rate gpm (lpm)
Wall Mount	Cart Mount	Stand Mount			Pump only	Pump and Gun	Gun Fluid Hose	Gun Air Hose	Gun Fluid Whip Hose	Siphon Kit	Fluid Filter	Hopper		
G18W01	-----		W18EAS	None									2.0 (7.5)	
G18W03	-----		W18EAS	None	✓									
G18W04	-----		W18EBS	None	✓							✓		
G18W05	G18C01		W18EAS	None	✓				✓	✓				
G18W06	G18C02		W18EBS	None	✓				✓	✓		✓		
-----	G18C03		W18EAS	None		✓			✓					
G18W07	G18C05		W18EAS	PerformAA 50		✓	✓	✓	✓	✓				
G18W08	G18C06		W18EBS	PerformAA 50		✓	✓	✓	✓	✓		✓		
G18W09	G18C07		W18EAS	PerformAA RAC		✓	✓	✓	✓	✓				
G18W10	G18C08		W18EBS	PerformAA RAC		✓	✓	✓	✓	✓		✓		

Merkur 23:1 Packages (G23Wxx and G23Cxx)

Maximum Inlet Air Pressure: 100 psi (0.7 MPa, 7 bar)

Maximum Fluid Working Pressure: 2300 psi (15.9 MPa, 159 bar)

Model		Pump Assembly	Gun	Air Controls		Hoses		Accessories			DataTrak	Maximum Fluid Flow Rate gpm (lpm)
Wall Mount	Cart Mount			Pump only	Pump and Gun	Gun Fluid Hose	Gun Air Hose	Siphon Kit	Fluid Filter	Hopper		
G23W01	-----	W23DAS	None									1.6 (6.0)
G23W03	-----	W23DAS	None	✓								
G23W04	-----	W23DBS	None	✓							✓	
-----	G23C01	W23DAS	None	✓				✓				
-----	G23C02	W23DBS	None	✓				✓			✓	
G23W05	-----	W23DAS	None	✓				✓	✓			
G23W06	-----	W23DBS	None	✓				✓	✓		✓	
G23W07	G23C03	W23DAS	XTR5	✓		✓		✓	✓			
G23W08	G23C04	W23DBS	XTR5	✓		✓		✓	✓		✓	
-----	G23C05	W23DAS	None		✓			✓				
-----	G23C07	W23DAS	PerformAA 50		✓	✓	✓			✓		
G23W09	G23C09	W23DAS	PerformAA 50		✓	✓	✓	✓	✓			
-----	G23C11	W23DAS	PerformAA 50		✓	✓	✓		✓	✓		
G23W10	G23C12	W23DBS	PerformAA 50		✓	✓	✓	✓	✓		✓	
G23W11	G23C13	W23DAS	PerformAA RAC		✓	✓	✓	✓	✓			
G23W12	G23C14	W23DBS	PerformAA RAC		✓	✓	✓	✓	✓		✓	

Merkur 24:1 Packages (G24Wxx and G24Cxx)

Maximum Inlet Air Pressure: 100 psi (0.7 MPa, 7 bar)

Maximum Fluid Working Pressure: 2400 psi (16.5 MPa, 165 bar)

Model		Pump Assembly	Gun	Air Controls		Hoses		Options			Maximum Fluid Flow Rate gpm (lpm)
Wall Mount	Cart Mount			Pump Only	Pump and Gun	Gun Fluid Hose	Gun Air Hose	Siphon Kit	Fluid Filter	DataTrak	
G24W01	-----	W24FAS									2.4 (9.0)
G24W02	-----	W24FBS		✓						✓	
G24W03	G24C01	W24FAS	None	✓				✓	✓		
G24W04	G24C02	W24FBS	None	✓				✓	✓	✓	
G24W05	G24C03	W24FAS	XTR5	✓		✓		✓	✓		
G24W06	G24C04	W24FBS	XTR5	✓		✓		✓	✓	✓	
G24W07	G24C09	W24FAS	PerformAA 50		✓	✓	✓	✓	✓		
G24W08	G24C10	W24FBS	PerformAA 50		✓	✓	✓	✓	✓	✓	
G24W09	G24C11	W24FAS	PerformAA RAC		✓	✓	✓	✓	✓		
G24W10	G24C12	W24FBS	PerformAA RAC		✓	✓	✓	✓	✓	✓	

Merkur 28:1 Packages (G28Wxx and G28Cxx)

Maximum Inlet Air Pressure: 100 psi (0.7 MPa, 7 bar)

Maximum Fluid Working Pressure: 2800 psi (19.3 MPa, 193 bar)

Model		Pump Assembly	Gun	Air Controls		Hoses		Accessories			Maximum Fluid Flow Rate gpm (lpm)
Wall Mount	Cart Mount			Pump Only	Pump and Gun	Gun Fluid Hose	Gun Air Hose	Siphon Kit	Fluid Filter	DataTrak	
G28W01	-----	W28EAS	None								2.0 (7.5)
G28W02	-----	W28EBS	None	✓						✓	
G28W03	G28C01	W28EAS	None	✓				✓	✓		
G28W04	G28C02	W28EBS	None	✓				✓	✓	✓	
G28W05	G28C03	W28EAS	XTR5	✓		✓		✓	✓		
G28W06	G28C04	W28EBS	XTR5	✓		✓		✓	✓	✓	
G28W11	G28C09	W28EAS	PerformAA 50		✓	✓	✓	✓	✓		
G28W12	G28C10	W28EBS	PerformAA 50		✓	✓	✓	✓	✓	✓	
G28W13	G28C11	W28EAS	PerformAA RAC		✓	✓	✓	✓	✓		
G28W14	G28C12	W28EBS	PerformAA RAC		✓	✓	✓	✓	✓	✓	

Merkur 30:1 Packages (G30Wxx, G30Cxx, and G30Txx)

Maximum Inlet Air Pressure: 100 psi (0.7 MPa, 7 bar)

Maximum Fluid Working Pressure: 3000 psi (20.7 MPa, 207 bar)

Model			Pump Assembly	Gun	Air Controls		Hoses		Accessories				DataTrak	Maximum Fluid Flow Rate gpm (lpm)
Wall Mount	Cart Mount	Stand Mount			Pump Only	Pump and Gun	Gun Fluid Hose	Gun Air Hose	Siphon Kit	Fluid Filter	Hopper	Drain Valve		
G30W19	-----		W30AAS											
G30W01	G30C01	-----	W30AAS	None	✓									
G30W03	G30C03	-----	W30AAS	None	✓				✓					
G30W05	G30C05	-----	W30AAS	None	✓				✓	✓				
-----	G30C07	-----	W30AAS	XTR5	✓		✓		✓					
-----	G30C08	-----	W30ABS	XTR5	✓		✓		✓				✓	
G30W07	G30C09	-----	W30AAS	XTR5	✓		✓		✓	✓				
G30W08	G30C10	-----	W30ABS	XTR5	✓		✓		✓	✓				✓
-----	G30C11	-----	W30AAS	XTR5	✓		✓				✓			
-----	G30C13	-----	W30AAS	XTR5	✓		✓**		✓	✓				
-----	G30C15	-----	W30AAS	XTR5	✓		✓		✓	✓				
G30W09	G30C17	-----	W30AAS	None			✓							
-----	-----	G30T01	W30AAS	None			✓	✓	✓	✓				
-----	-----	G30T02	W30ABS	None			✓	✓	✓	✓				✓
G30W11	G30C19	-----	W30AAS	None			✓		✓					
G30W12	-----	-----	W30ABS	None			✓		✓					✓
G30W13	G30C21	G30T03	W30AAS	PerformAA 50			✓	✓	✓	✓				
G30W14	G30C22	G30T04	W30ABS	PerformAA 50			✓	✓	✓	✓				✓
-----	G30C23	G30T09	W30AAS	PerformAA 50			✓	✓	✓			✓		
G30W15	G30C25	G30T05	W30AAS	PerformAA 50			✓	✓	✓	✓	✓			
G30W16	G30C26	G30T06	W30ABS	PerformAA 50			✓	✓	✓	✓	✓			✓
-----	G30C27	-----	W30AAS	PerformAA 50			✓	✓	✓		✓	✓		
-----	G30C29	G30T07	W30AAS	PerformAA RAC			✓	✓	✓	✓				
-----	G30C30	G30T08	W30ABS	PerformAA RAC			✓	✓	✓	✓				✓
-----	G30C31	-----	W30AAS	PerformAA RAC			✓	✓	✓			✓		
G30W17	G30C33	G30T11	W30AAS	PerformAA RAC			✓	✓	✓	✓	✓			
G30W18	G30C34	G30T12	W30ABS	PerformAA RAC			✓	✓	✓	✓	✓			✓
-----	G30C35	-----	W30AAS	PerformAA RAC			✓	✓	✓		✓	✓		

0.4 (1.5)

* This package offers a short suction tube, rather than the standard suction hose.

** Fluid hose is 3/16 x 50 ft., rather than standard 3/16 x 25 ft.

Model			Pump Assembly	Gun	Air Controls		Hoses		Accessories				DataTrak	Maximum Fluid Flow Rate gpm (lpm)
Wall Mount	Cart Mount	Stand Mount			Pump Only	Pump and Gun	Gun Fluid Hose	Gun Air Hose	Siphon Kit	Fluid Filter	Hopper	Drain Valve		
-----	G30C37	-----	W30AAS	XTR5	✓		✓		✓*	✓				0.4 (1.5)
-----	G30C39	-----	W30AAS	PerformAA 50		✓	✓	✓	✓	✓		✓		
-----	G30C40	-----	W30ABS	PerformAA 50		✓	✓	✓	✓	✓		✓	✓	
G30W51	-----		W30CAS	None										1.2 (4.5)
G30W53	-----		W30CAS	None	✓									
-----	G30C51		W30CAS	None	✓				✓					
G30W55	G30C53		W30CAS	None	✓				✓	✓				
G30W56	G30C54		W30CBS	None	✓				✓	✓			✓	
G30W57	-----		W30CAS	XTR5	✓		✓		✓					1.2 (4.5)
G30W58	-----		W30CBS	XTR5	✓		✓		✓				✓	
G30W59	G30C55		W30CAS	XTR5	✓		✓		✓	✓				
G30W60	G30C56		W30CBS	XTR5	✓		✓		✓	✓			✓	
-----	G30C57		W30CAS	XTR5	✓		✓**		✓	✓				
G30W71	-----		W30CAS	None		✓								
-----	G30C63		W30CAS	None		✓			✓					
-----	G30C65		W30CAS	PerformAA 50		✓	✓	✓			✓			
G30W73	G30C67		W30CAS	PerformAA 50		✓	✓	✓	✓	✓				
G30W74	G30C68		W30CBS	PerformAA 50		✓	✓	✓	✓	✓			✓	
-----	G30C69		W30CAS	PerformAA 50		✓	✓**	✓	✓	✓				
-----	G30C71		W30CAS	PerformAA RAC		✓	✓	✓			✓			
G30W75	G30C73		W30CAS	PerformAA RAC		✓	✓	✓	✓	✓				
G30W76	G30C74		W30CBS	PerformAA RAC		✓	✓	✓	✓	✓			✓	
-----	G30C85		W30CAS	XTR5		✓	✓	✓	✓	✓		✓		
-----	G30C86		W30CBS	XTR5		✓	✓	✓	✓	✓		✓	✓	
G30W87	G30C97		W30CAS	PerformAA 50 Airless	✓		✓		✓	✓				
-----	G30C99		W30CAS	PerformAA 50 Airless	✓		✓		✓	✓		✓		

* This package offers a short suction tube, rather than the standard suction hose.

** Fluid hose is 3/16 x 50 ft., rather than standard 3/16 x 25 ft.

Merkur 36:1 Packages (G36Wxx and G36Cxx)

Maximum Inlet Air Pressure: 100 psi (0.7 MPa, 7 bar)

Maximum Fluid Working Pressure: 3600 psi (24.8 MPa, 248 bar)

Model		Pump Assembly	Gun	Air Controls		Hoses			Accessories			DataTrak	Maximum Fluid Flow Rate gpm (lpm)
Wall Mount	Cart Mount			Pump Only	Pump and Gun	Gun Fluid Hose	Gun Fluid Whip Hose	Gun Air Hose	Suction Hose	Fluid Filter	Drain Valve		
G36W01	-----	W36DAS	None										1.6 (6.0)
G36W03	-----	W36DAS	None	✓									
G36W04	-----	W36DBS	None	✓								✓	
G36W05	G36C01	W36DAS	None	✓					✓	✓			
G36W06	G36C02	W36DBS	None	✓					✓	✓		✓	
G36W07	G36C03	W36DAS	XTR5RAC	✓		✓			✓	✓			
G36W08	G36C04	W36DBS	XTR5RAC	✓		✓			✓	✓		✓	
G36W13	G36C09	W36DAS	PerformAA 50		✓	✓	✓	✓	✓	✓			
G36W14	G36C10	W36DBS	PerformAA 50		✓	✓	✓	✓	✓	✓		✓	
G36W15	G36C11	W36DAS	PerformAA RAC		✓	✓	✓	✓	✓	✓			
G36W16	G36C12	W36DBS	PerformAA RAC		✓	✓	✓	✓	✓	✓		✓	
G36W17	G36C13	W36DAS	PerformAA 50		✓	✓	✓	✓	✓	✓	✓		
G36W18	G36C14	W36DBS	PerformAA 50		✓	✓	✓	✓	✓	✓	✓	✓	
-----	G36C15	W36DAS	XTR5RAC	✓		✓			✓	✓	✓		
-----	G36C16	W36DBS	XTR5RAC	✓		✓			✓	✓	✓	✓	
G36W19		W26DAS	PerformAA 50, WB		✓	✓	✓	✓	✓	✓			

Merkur 45:1 Packages (G45Wxx and G45Cxx)

Maximum Inlet Air Pressure: 100 psi (0.7 MPa, 7 bar)

Maximum Fluid Working Pressure: 4500 psi (31.0 MPa, 310 bar)

Model		Pump Assembly	Gun	Air Controls		Hoses			Accessories				Data Trak	Maximum Fluid Flow Rate gpm (lpm)
Wall Mount	Cart Mount			Pump Only	Pump and Gun	Gun Fluid Hose	Gun Fluid Whip Hose	Gun Air Hose	Siphon Kit	Fluid Filter	Hopper	Drain Valve		
G45W01	-----	W45BAS	None											0.8 (3.0)
G45W03	-----	W45BAS	None	✓										
G45W04	-----	W45BBS	None	✓		✓			✓	✓			✓	
-----	G45C01	W45BAS	None	✓					✓					
G45W05	G45C03	W45BAS	XTR5RAC	✓		✓			✓	✓				
G45W06	G45C04	W45BBS	XTR5RAC	✓		✓			✓	✓			✓	
-----	G45C05	W45BAS	XTR5RAC	✓		✓				✓	✓			
-----	G45C06	W45BBS	XTR5RAC	✓		✓				✓	✓		✓	
G45W11	-----	W45BAS	None		✓									
-----	G45C11	W45BAS	None		✓				✓					
G45W21	G45C25	W45BAS	PerformAA 50 Airless	✓		✓			✓	✓				0.8 (3.0)
-----	G45C13	W45BAS	PerformAA 50		✓	✓	✓	✓			✓			
G45W13	G45C15	W45BAS	PerformAA 50		✓	✓	✓	✓	✓	✓				
G45W14	G45C16	W45BBS	PerformAA 50		✓	✓	✓	✓	✓	✓			✓	
G45W15	G45C17	W45BAS	PerformAA RAC		✓	✓	✓	✓	✓	✓				
G45W16	G45C18	W45BBS	PerformAA RAC		✓	✓	✓	✓	✓	✓			✓	
G45W17	G45C19	W45BAS	PerformAA 50		✓	✓	✓	✓	✓	✓		✓		
G45W18	G45C20	W45BBS	PerformAA 50		✓	✓	✓	✓	✓	✓		✓	✓	
-----	G45C21	W45BAS	PerformAA 50		✓	✓	✓	✓		✓	✓	✓		

Merkur 48:1 Packages (G48Wxx and G48Cxx)

Maximum Inlet Air Pressure: 100 psi (0.7 MPa, 7 bar)

Maximum Fluid Working Pressure: 4800 psi (33.1 MPa, 331 bar)

Model		Pump Assembly	Gun	Air Controls		Hoses			Accessories				DataTra k	Maximum Fluid Flow Rate gpm (lpm)
Wall Mount	Cart Mount			Pump Only	Pump and Gun	Gun Fluid Hose	Gun Fluid Whip Hose	Gun Air Hose	Siphon Kit	Fluid Filter	Hopper	Drain Valve		
G48W01		W48CAS	None											1.2 (4.5)
G48W03	G48C01	W48CAS	None	✓					✓	✓				
G48W04	G48C02	W48CBS	None	✓					✓	✓			✓	
G48W05	G48C03	W48CAS	XTR5 RAC	✓		✓			✓	✓				
G48W06	G48C04	W48CBS	XTR5 RAC	✓		✓			✓	✓			✓	
-----	G48C05	W48CAS	XTR5 RAC	✓		✓			✓	✓		✓		
-----	G48C06	W48CBS	XTR5 RAC	✓		✓			✓	✓		✓	✓	
G48W11	-----	W48CAS	None		✓									1.2 (4.5)
G48W07	G48C07	W48CAS	Perfor mAA 50		✓	✓	✓	✓	✓	✓*		✓		
G48W08	G48C08	W48CBS	Perfor mAA 50		✓	✓	✓	✓	✓	✓*		✓	✓	
-----	G48C09	W48CAS	Perfor mAA 50		✓	✓	✓	✓			✓			
G48W13	G48C11	W48CAS	Perfor mAA 50		✓	✓	✓	✓	✓	✓				
G48W14	G48C12	W48CBS	Perfor mAA 50		✓	✓	✓	✓	✓	✓			✓	
G48W15	G48C13	W48CAS	Perfor mAA RAC		✓	✓	✓	✓	✓	✓				
G48W16	G48C14	W48CBS	Perfor mAA RAC		✓	✓	✓	✓	✓	✓			✓	

Installation

Package configurations vary widely. See pages 7-16 to determine the components included in your model. Items designated as accessories are not included in the packages.

- | | | | |
|---|---|---|--|
| A | Air Shutoff Valve (optional accessory) | L | Air-Assisted Spray Gun |
| B | Air Filter (optional accessory) | M | Gun Fluid Supply Hose |
| C | Gun Air Pressure Gauge | N | Gun Air Supply Hose |
| D | Gun Air Pressure Regulator | P | Fluid Filter |
| E | Bleed Type Master Air Valve (3/8-18 npt(f)) | R | Pump Fluid Outlet |
| F | DataTrak™ | S | Grounding Wire |
| G | Pump Air Pressure Gauge | T | Wet-Cup (not visible, see FIG. 4, page 21) |
| H | Pump Air Pressure Regulator | U | Pump Fluid Inlet |
| J | Solenoid Release Button (DataTrak equipped packages only, not visible, see FIG. 8, page 27) | V | Suction Hose |
| K | Gun Swivel | W | Fluid Drain Valve |

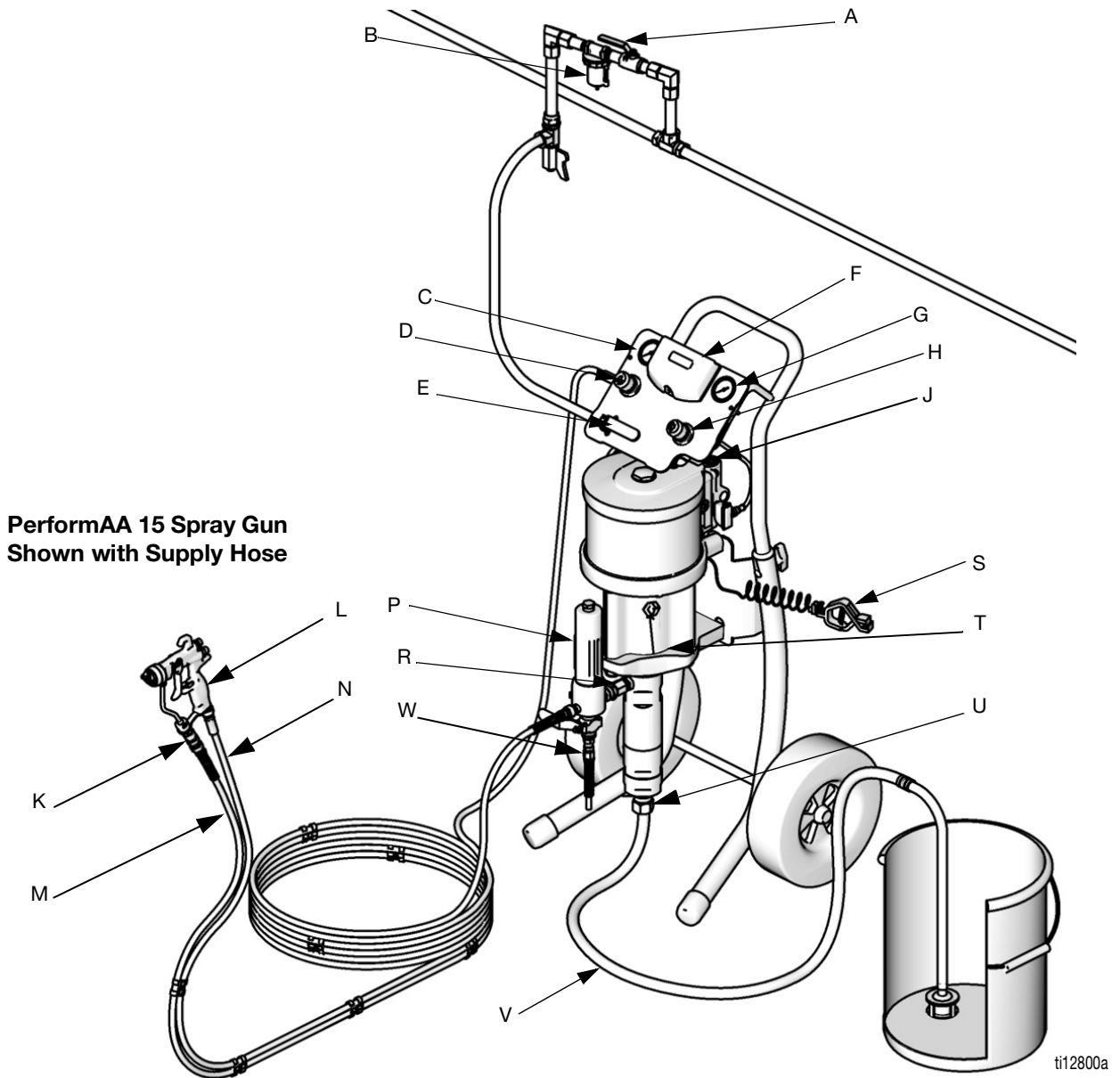

FIG. 1. Typical Installation (Your package may not include all items shown.)

General Information

NOTE: Reference numbers and letters in parentheses in the text refer to the callouts in the figures and the parts drawing.

NOTE: Always use Genuine Graco Parts and Accessories, available from your Graco distributor. If you supply your own accessories, be sure they are adequately sized and pressure-rated for your system.

FIG. 1 is only a guide for selecting and installing system components and accessories. Contact your Graco distributor for assistance in designing a system to suit your particular needs.

Prepare the Operator

All persons who operate the equipment must be trained in the operation of all system components as well as the proper handling of all fluids. All operators must thoroughly read all instruction manuals, tags, and labels before operating the equipment.

Prepare the Site

Ensure that you have an adequate compressed air supply.

Bring a compressed air supply line from the air compressor to the pump location. Be sure all air hoses are properly sized and pressure-rated for your system. Use only electrically conductive hoses. The air hose should have a 3/8 npt(m) thread. A quick disconnect coupling is recommended.

Keep the site clear of any obstacles or debris that could interfere with the operator's movement.

Have a grounded, metal pail available for use when flushing the system.

Wall Mount Packages

1. Be sure the wall can support the weight of the pump, bracket, hoses and accessories, as well as the stress caused during operation.
2. Position the wall bracket about 1.2-1.5 m (4-5 ft) above the floor. For ease of operation and service, make sure the pump air inlet, fluid inlet, and fluid outlet ports are easily accessible.
3. Using the wall bracket as a template, drill 10 mm (0.4 in.) mounting holes in the wall. Wall mounting dimensions are shown on page 50.
4. Attach the bracket to the wall. Use 3/8 in. (9 mm) screws that are long enough to keep the pump from vibrating during operation.

NOTE: Be sure the bracket is level.

Cart Mount Packages

In packages with M012xx and M018xx motors the muffler(s) are shipped loose. Ensure the muffler(s) are installed before first use.

Components

See FIG. 1. **Components vary by package ordered.** See tables on pages 7 to 16. Your package may include:

- The red-handled bleed-type master air valve (E) is required in your system to relieve air trapped between it and the air motor and gun when the valve is closed. Do not block access to the valve.
- The pump air regulator (H) controls pump speed and outlet pressure by adjusting the air pressure to the pump.
- The air relief valve (not shown) opens automatically to prevent overpressurization of the pump.
- The gun air regulator (D) adjusts the air pressure to the air-assisted spray gun (L).
- The air-assisted or airless spray gun (L) dispenses the fluid. The gun houses the spray tip (not shown), which is available in a wide range of sizes for different spray patterns and rates of flow. Refer to gun manual for tip installation.
- The transparent hose (N, labeled “Air Hose Only”) provides the gun air supply.
- The blue hose (M) provides the gun fluid supply.
- The gun swivel (K) allows for freer gun movement and comes attached to the blue hose (AA packages). The airless gun has a built-in fluid swivel.
- The suction hose (V) with strainer allows the pump to draw fluid from a 5 gallon (19 liter) pail. A fluid hopper with screen also is available.
- A fluid filter (P) with a 60 mesh (250 micron) stainless steel element filters particles from fluid as it leaves the pump.
- A fluid drain valve (W) relieves fluid pressure in the hose and gun.
- DataTrak (F) provides pump diagnostics and material usage information. DataTrak equipped packages with M02xxx air motors do not have a runaway solenoid; all other DataTrak equipped packages do. See page 26.

Air Line Accessories

See manual 308169.

Install the following accessories in the order shown in FIG. 1, using adapters as necessary.

- An air-line filter (B) removes harmful dirt and moisture from the compressed air supply.
- A second bleed-type air shutoff valve (A) isolates the air line accessories for servicing. Locate upstream from all other air line accessories.

Grounding

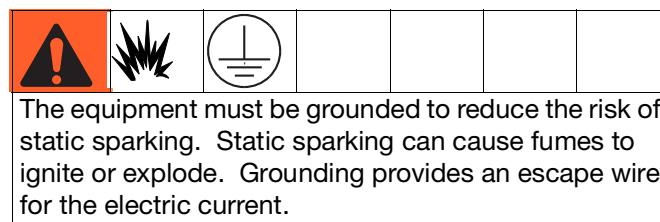

1. Pump: See FIG. 2. Verify that the ground screw (GS) is attached and tightened securely to the air motor. Connect the other end of the ground wire (S) to a true earth ground.

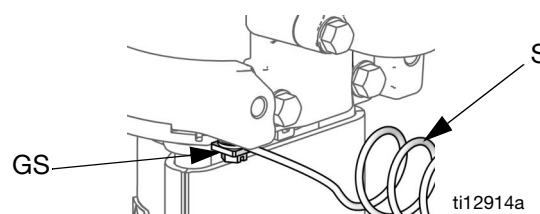

FIG. 2. Ground screw and wire

2. Pump fluid hoses: use only electrically conductive fluid hoses. Check electrical resistance of hoses. If total resistance to ground exceeds 25 megohms, replace hose immediately.
3. Air compressor: follow manufacturer's recommendations.
4. Spray gun: ground through connection to a properly grounded fluid hose and pump.

5. Fluid supply container: follow your local code.
6. Object being sprayed: follow your local code.
7. Solvent pails used when flushing: follow your local code. Use only metal pails, which are conductive, placed on a grounded surface. Do not place the pail on a nonconductive surface, such as paper or cardboard, which interrupts the grounding continuity.
8. To maintain grounding continuity when flushing or relieving pressure, hold a metal part of the spray gun firmly to the side of a grounded metal pail, then trigger the gun.

Setup

1. See FIG. 1. Attach end of blue fluid hose (M) to pump outlet (R) or filter (P) outlet.
2. Attach one end of the air hose (N) to gun air regulator (D).
3. Attach remaining end of the air hose (N) to air inlet at base of gun (L).
4. Attach gun swivel (K) to gun fluid inlet.
5. Attach other end of blue fluid hose (M) to gun swivel (K).
6. Clip fluid and air hoses together with the supplied hose clips (qty. of 7). Space clips as needed.
7. Apply lens cover to both regulator gauge lenses.
8. Verify that suction hose fittings are tight.

Operation

Pressure Relief Procedure

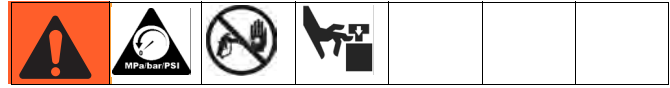

1. Engage the trigger lock.
2. See FIG. 1. Turn off the bleed-type master air valve (D).
3. Disengage the trigger lock.
4. Hold a metal part of the gun firmly to a grounded metal waste container. Trigger the gun to relieve fluid pressure.
5. Engage the trigger lock.
6. Open all fluid drain valves in the system, having a waste container ready to catch the drainage. Leave the drain valve(s) open until you are ready to spray again.
7. If you suspect that pressure has not been fully relieved after following the steps above, check the following:
 - a. The spray tip may be completely clogged. Very slowly loosen the air cap retaining ring to relieve pressure in the cavity between the ball/seat shutoff and the plugged tip. Clear the tip orifice.
 - b. The gun fluid filter or the fluid hose may be completely clogged. Very slowly loosen the hose end coupling at the gun and relieve pressure gradually. Then loosen completely to clear the obstruction.
 - c. After following the steps above, if the spray tip or hose still seems completely clogged, very slowly loosen the tip guard retaining nut or hose end coupling and relieve pressure gradually, then loosen completely. With tip removed, trigger gun into waste container.

Flush the Pump Before First Use

The pump is tested with lightweight oil, which is left in to protect the pump parts. If the fluid you are using may be contaminated by the oil, flush it out with a compatible solvent. See **Flush the Pump** on page 24.

Trigger Lock

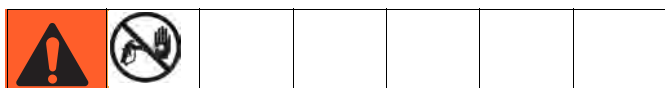

See FIG. 3. Always engage gun trigger lock when you stop spraying to prevent gun from being triggered accidentally by hand or if dropped or bumped.

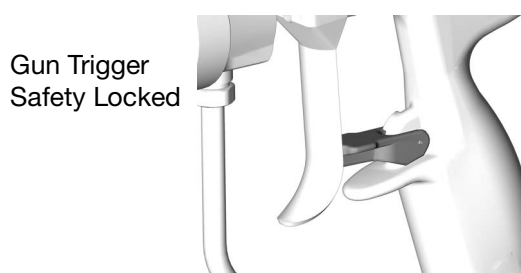

Ti6581A

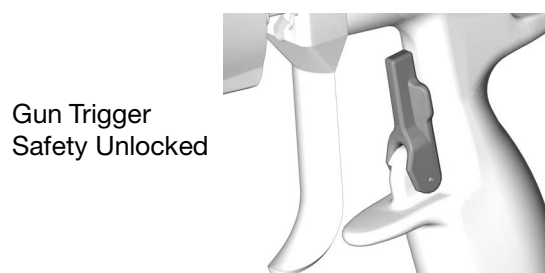

Ti6582A

FIG. 3. Trigger Lock

Wet Cup

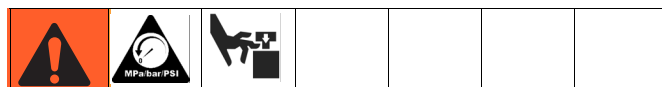

Before starting, fill wet cup (T) 1/3 full with Graco Throat Seal Liquid (TSL) or compatible solvent.

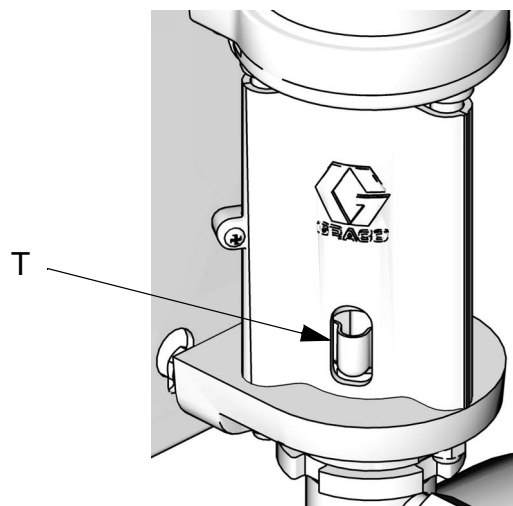

ti11927a

FIG. 4. Wet Cup

Prime the Pump

1. See FIG. 1. Lock gun trigger. Remove tip guard and spray tip from gun (L). Refer to gun manual.
2. Close gun air regulator (D) and pump air regulator (H) by turning knobs counterclockwise reducing pressure to zero. Close bleed-type air valve (E). Also verify that all drain valves are closed.
3. Connect air line to bleed type air valve (D).
4. Check that all fittings throughout system are tightened securely.
5. Position pail close to pump. Suction hose is 4 ft (1.2 m) long. Do not stretch hose tight; let it hang to assist fluid flow into pump.
6. Hold metal part of gun (L) firmly to side of grounded metal pail, unlock trigger, and hold trigger open.
7. *Units with runaway protection only:* enable the prime/flush function by pushing the prime/flush button on the DataTrak.

8. Open bleed-type air valve (E). Slowly turn clockwise pump air regulator (H) increasing pressure until pump starts.
9. Cycle pump slowly until all air is pushed out and pump and hoses are fully primed.
10. *Units with runaway protection only:* disable the prime/flush function by pushing the prime/flush button on the DataTrak.
11. Release gun trigger and lock trigger safety. Pump should stall against pressure.

Install the Spray Tip

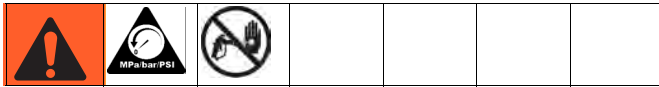

Follow **Pressure Relief Procedure**, page 20. Install the spray tip and tip guard as explained in your separate gun manual, supplied.

The fluid output and pattern width depend on the size of the spray tip, the fluid viscosity, and the fluid pressure. Use the Spray Tip Selection Chart in your gun instruction manual as a guide for selecting an appropriate spray tip for your application.

Adjust the Atomization



1. Do not turn on atomizing air supply. Fluid pressure is controlled by the air pressure supplied to the pump (pump air regulator). Set fluid pressure at low starting pressure. For low viscosity fluids (less than 25 sec, #2 Zahn cup) with lower percent solids (typically less than 40%), start at 300 psi (2.1 MPa, 21 bar) at pump outlet. For fluids with higher viscosity or higher solids content, start at 600 psi (4.2 MPa, 42 bar). Refer to the following example.

Example:

Pump Ratio		Pump Air Regulator Setting psi (MPa, bar)	=	Approximate Fluid Pressure psig (MPa, bar)
15:1	x	20 (0.14, 1.4)	=	300 (2.1, 21)
30:1	x	20 (0.14, 1.4)	=	600 (4.2, 42)

2. Hold gun perpendicular and approximately 12 inches (304 mm) from surface.
3. Move gun first, then pull gun trigger to spray onto test paper.
4. Increase fluid pressure in 100 psi (0.7 MPa, 7 bar) increments, just to the point where a further increase in fluid pressure does not significantly improve fluid atomization. Refer to the following example.

Example:

Pump Ratio		Pump Air Regulator Increment psi (MPa, bar)	=	Incremental Fluid Pressure psi (MPa, bar)
15:1	x	7 (.05, 0.5)	=	100 (0.7, 7.0)
30:1	x	3.3 (0.02, 0.2)	=	100 (0.7, 7.0)

Adjust the Spray Pattern

Packages with Airless Guns

The spray tip orifice and spray angle determine pattern coverage and size. When you need more coverage, use a larger spray tip rather than increasing fluid pressure. Align guard horizontally to spray a horizontal pattern. Align guard vertically to spray a vertical pattern.

Packages with AA Guns

1. See FIG. 5. Close off pattern adjustment air by turning knob (AA) clockwise (in) all the way. This sets gun for its widest pattern.

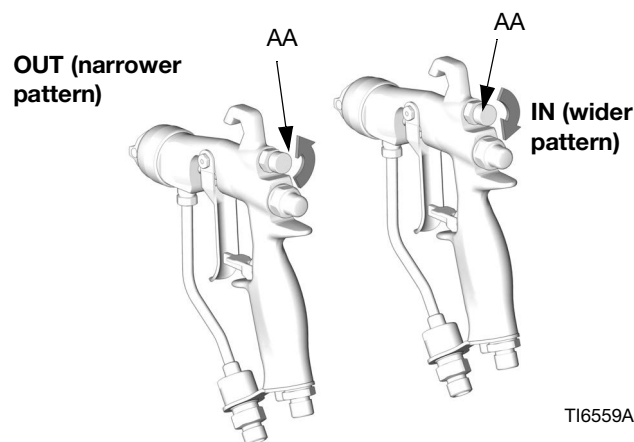

T16559A

FIG. 5. Pattern Air Knob

2. See FIG. 6. Set atomizing air pressure at about 5 psi (0.35 bar, 35 kPa) when triggered. Check spray pattern, then slowly increase air pressure until tails are completely atomized and pulled into spray pattern. Do not exceed 100 psi (0.7 MPa, 7 bar) air pressure to gun.

3. See FIG. 5. For narrower pattern, turn pattern adjustment valve knob (AA) counterclockwise (out). If pattern is still not narrow enough, increase air pressure to gun slightly or use different size tip.

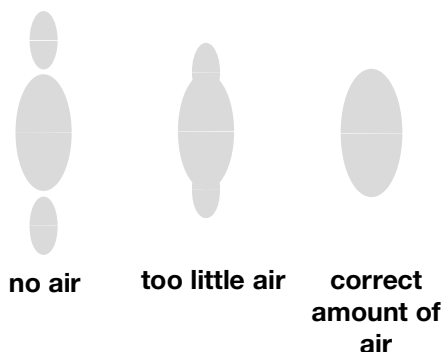

T10792A

FIG. 6. Spray Pattern Problems

Shutdown



Follow **Pressure Relief Procedure**, page 20.

Always flush the pump before the fluid dries on the displacement rod. See **Flush the Pump** on page 24.

Maintenance

Preventive Maintenance Schedule



The operating conditions of your particular system determine how often maintenance is required. Establish a preventive maintenance schedule by recording when and what kind of maintenance is needed, and then determine a regular schedule for checking your system.

Replace lens covers on regulator gauge lenses when dirt makes gauges difficult to read.

Tighten Threaded Connections

Before each use, check all hoses for wear or damage. Replace as necessary. Check that all threaded connections are tight and leak-free.

Flush the Pump

						
Read all Warnings . Follow all Grounding instructions. See page 19 .						

Flush the pump:

- Before first use
- When changing colors or fluids
- Before repairing equipment
- Before fluid dries or settles out in a dormant pump (check the pot life of catalyzed fluids)
- At the end of the day
- Before storing the pump.



Flush at the lowest pressure possible. Flush with a fluid that is compatible with the fluid you are pumping and with the wetted parts in your system. Check with your fluid manufacturer or supplier for recommended flushing fluids and flushing frequency.

1. Follow **Pressure Relief Procedure**, page 20.
2. Remove tip guard and spray tip from gun. Refer to separate gun manual.
3. Place siphon tube in grounded metal pail containing cleaning fluid.
4. Set pump to lowest possible fluid pressure, and start pump.
5. Hold a metal part of the gun firmly to a grounded metal pail.
6. *Units with runaway protection only:* enable the prime/flush function by pushing the prime/flush button on the DataTrak.
7. Trigger gun. Flush system until clear solvent flows from gun.
8. *Units with runaway protection only:* disable the prime/flush function by pushing the prime/flush button on the DataTrak.
9. Follow **Pressure Relief Procedure**, page 20.
10. Clean the tip guard, spray tip, and fluid filter element separately, then reinstall them.
11. Clean inside and outside of suction tube.

Wet Cup

Fill the wet cup one-half full with Graco Throat Seal Liquid (TSL). Maintain level daily.

Troubleshooting

						
<p>Relieve the pressure before checking or servicing the equipment.</p>						

NOTE: Check all possible problems and causes before disassembling the pump.

Problem	Cause	Solution
Pump fails to operate.	Restricted line or inadequate air supply; closed or clogged valves.	Clear line or increase air supply. Check that the valves are open.
	Obstructed fluid hose or gun; fluid hose ID is too small.	Open, clear*; use hose with larger ID.
	Fluid dried on the displacement rod.	Clean; always stop the pump at the bottom of its stroke; keep the wet-cup 1/3 filled with Graco throat seal liquid (TSL).
	Dirty, worn, or damaged air motor parts.	Clean or repair air motor. See manual 312796.
	DataTrak models only: Air valve cannot cycle because solenoid pin is extended.	Enable runaway protection (See DataTrak Operation, Setup Mode , page 27). Bleed air from motor. Press  on the DataTrak display to retract solenoid pin.
Pump operates, but output is low on both strokes.	Restricted line or inadequate air supply; closed or clogged valves.	Clear line or increase air supply. Check that the valves are open.
	Obstructed fluid hose or gun; fluid hose ID is too small.	Open, clear*; use hose with larger ID.
	Worn packings in displacement pump.	Replace packings. See manual 312792.
Pump operates, but output is low on downstroke.	Held open or worn ball check valves or piston packings.	Clear valve; replace packings. See manual 312792.
Erratic or accelerated pump speed.	Exhausted fluid supply.	Refill and prime.
	Held open or worn ball check valves or packings.	Clear valve, replace packings; see manual 312792.
Fluid being pumped is visible in the TSL reservoir.	Worn throat packings.	Replace throat packings. See manual 312792.

* To determine if the fluid hose or gun is obstructed, relieve the pressure. Disconnect the fluid hose and place a container at the pump fluid outlet to catch any fluid. Turn on the air just enough to start the pump. If the pump starts when the air is turned on, the obstruction is in the hose or gun.

DataTrak Controls and Indicators

Key for FIG. 7

- AA Runaway Limit, in cycles per minute (user settable; 00=OFF)
- AB Lower Displacement (user settable)
- AC Flow Rate Units (user settable to \updownarrow /min, gpm [US], gpm [Imperial], oz/min [US], oz/min [Imperial], l/min, or cc/min)
- AD LED (fault indicator when lit)
- AE Display
- PF Prime/Flush Key (Enables Prime/Flush mode. While in Prime/Flush mode, runaway protection is disabled and the batch totalizer [BT] will not count.) LED will flash while in Prime/Flush mode.

- RK Reset Key (Resets faults. Press and hold for 3 seconds to clear the batch totalizer.) Push to toggle between flow rate and cycle rate. With runaway protection enabled, push to extend and retract the solenoid pin.
- CF Cycle/Flow Rate
- BT Batch Totalizer
- GT Grand Totalizer
- RT Runaway Toggle (enable/disable)
- UT E1 Toggle
- DT E2 Toggle
- ST E5 Toggle

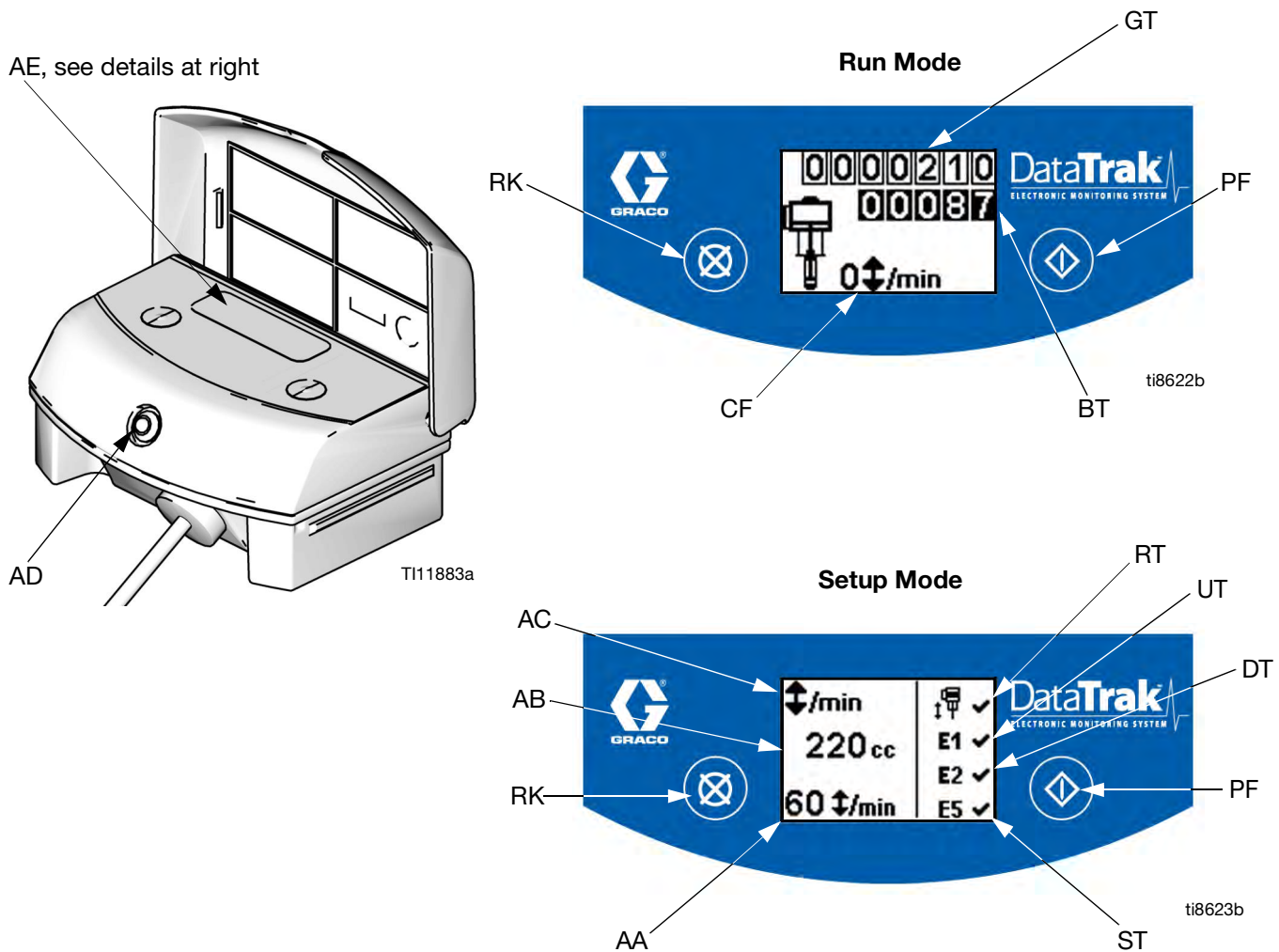

FIG. 7. DataTrak Controls and Indicators



DataTrak Operation

NOTE: The display (AE) will turn off after 1 minute to save battery life. Press any key to wake up the display.

NOTICE

To prevent damage to the soft key buttons, do not press the buttons with sharp objects such as pens, plastic cards, or fingernails.

Setup Mode

1. See FIG. 7. Press and hold  for 5 seconds until Setup menu appears.
2. To enter settings for runaway (if equipped), lower size, and flow rate units, and to enable runaway, E1, E2, and E5 error options, press  to change the value, then  to save the value and move the cursor to the next data field. See page 28 for a description of E1, E2, and E5 error codes.

NOTE: Graco recommends setting runaway (if equipped) to 60 . All DataTrak modules are shipped with runaway protection not enabled.

NOTE: When runaway, E1, E2, and E5 error options are enabled, a ✓ will appear on the setup screen. See FIG. 7.

3. Move the cursor to the E5 error enable option field, then press  once more to exit Setup mode.

Run Mode

Runaway

NOTE: DataTrak is available with and without runaway protection. Packages with M02xxx air motors ship without a runaway solenoid. All other packages are equipped with a runaway solenoid.

1. See FIG. 7. If pump runaway occurs, the runaway solenoid will actuate, stopping the pump. The LED (AD) will flash and the display (AE) will indicate a runaway condition (see Table 1). The display will cycle through six instruction screens.

2. Runaway Screens 1 and 2: To reset the runaway solenoid, close the master air valve (E). Wait for air to completely bleed off the air motor.

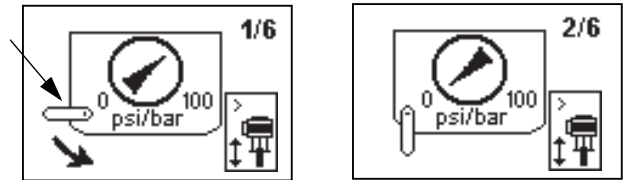

3. Runaway Screens 3 and 4: After the air is bled off, push the solenoid release button (J) down to reset the air valve. The button will pop back up when the air valve is repressurized.

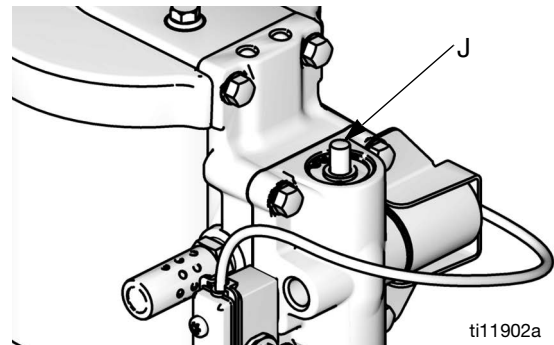
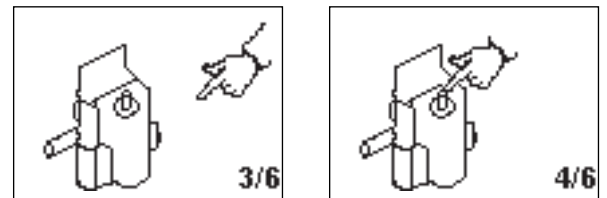

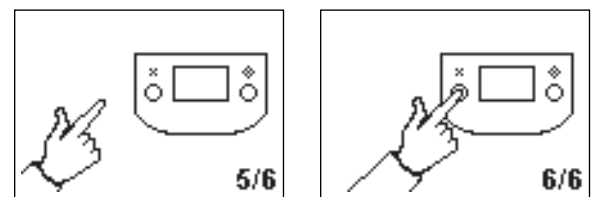



FIG. 8. Solenoid Release Button

4. Runaway Screens 5 and 6: Press  to clear the diagnostic code and reset the runaway solenoid.



5. Open master air valve (E) to restart pump.

NOTE: To disable runaway monitoring, go to setup mode and set runaway value to 0 (zero) or toggle (RT) off  (see FIG. 7).

Prime/Flush

1. See FIG. 7. To enter Prime/Flush mode, press any key to wake up the display, then press . The Prime/Flush symbol will appear in the display and

the LED will flash

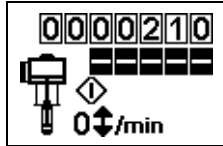

2. While in Prime/Flush mode, runaway protection is disabled and the batch totalizer (BT) will not count. The grand totalizer (GT) continues to count.
3. To exit Prime/Flush mode, press any key to wake up the display, then press . The Prime/Flush symbol will disappear from the display and the LED will stop flashing.

Counter/Totalizer

See FIG. 7. The last digit of the batch totalizer (BT) represents tenths of gallons or liters. To reset the totalizer, press any key to wake up the display, then press and hold  for 3 seconds.

- If AC is set to gallons or ounces, BT and GT display gallons.
- If AC is set to liters or cc, BT and GT display liters.
- If AC is set to cycles, BT and GT display cycles.

Press  to toggle between flow rate units and cycles. A letter under the BT display indicates that both BT and GT are displaying gallons (g) or liters (l). No letter means both BT and GT are displaying cycles.

Display

See FIG. 7. The display (AE) will turn off after 1 minute of inactivity in Run mode or 3 minutes in Setup mode. Press any key to wake up the display.

NOTE: DataTrak will continue to count cycles when display is off.

NOTE: The display (AE) may turn off if a high-level static discharge is applied to the DataTrak. Press any key to wake up the display.

Diagnostics

DataTrak can diagnose several problems with the pump. When the monitor detects a problem, the LED (AD, FIG. 7) will flash and a diagnostic code will appear on the display. See Table 1.







To acknowledge the diagnosis and return to the normal operating screen, press  once to wake up the display, and once more to clear the diagnostic code screen

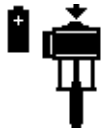

Table 1: Diagnostic Codes

Symbol	Code	Code Name	Diagnosis	Cause
		Runaway (DataTrak only)	Pump running faster than set runaway limit.	<ul style="list-style-type: none"> • Increased air pressure. • Increased fluid output. • Exhausted fluid supply.
	E-1	Diving Up	Leak during upstroke.	Worn piston valve or packings.

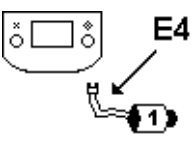
Table 1: Diagnostic Codes

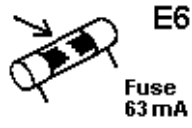
Symbol	Code	Code Name	Diagnosis	Cause
 E2	E-2	Diving Down	Leak during downstroke.	Worn intake valve.
 E3	E-3	Low Battery	Battery voltage too low to stop runaway.	Low battery. Replace battery; see page 30.
 E4	E-4	Service Component 1 (units with runaway protection only)	Problem with stopping runaway.	<ul style="list-style-type: none"> Damaged solenoid. Damaged valve carriage. Runaway (RT, FIG. 7) protection may be enabled with pump that is not equipped with a runaway solenoid valve. Enter setup screen and disable runaway protection.
 E4	E-4	Disconnected Solenoid (units with runaway protection only)	Solenoid is disconnected.	<ul style="list-style-type: none"> Solenoid unplugged. Damaged solenoid wires.
			Solenoid is not engaging piston cup (112).	<ul style="list-style-type: none"> Bracket and solenoid not tight against air valve housing.
 E5	E-5	Service Component 2	Problem with sensing valve movement.	<ul style="list-style-type: none"> Sensors unplugged. Sensors mounted incorrectly. Damaged sensors. Damaged valve carriage.
 E6 Fuse 63 mA	E-6	Blown Fuse	Fuse is blown. Replace fuse; see page 30.	<ul style="list-style-type: none"> Faulty solenoid or solenoid wiring. Extreme temperatures (above 140°F [60°C]). Runaway (RT, FIG. 7) protection may be enabled with pump that is not equipped with a runaway solenoid valve. Enter setup screen and disable runaway protection.

Replace DataTrak Battery or Fuse

						
<p>To reduce the risk of fire and explosion, the battery and fuse must be replaced in a non-hazardous location.</p> <p>Use only an approved replacement battery, shown in TABLE 2, and an approved fuse, shown in TABLE 3. Use of an unapproved battery or fuse will void Graco's warranty and Intertek and Ex approvals.</p>						

- Remove two screws on back of module to access battery.
- See FIG. 11. Disconnect the used battery and replace with an approved battery from TABLE 2.

Table 2. Approved Batteries
Energizer alkaline # 522
Varta alkaline # 4922
Ultralife lithium # U9VL
Duracell alkaline # MN1604

Replace Battery

- Unscrew cable from the back of the reed switch assembly. See FIG. 9.
- Remove the cable from the two cable clips.

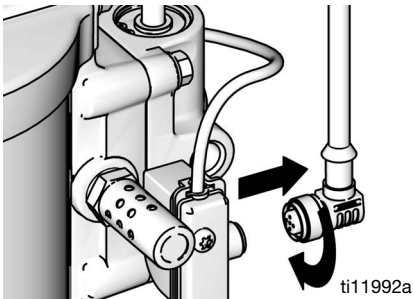

FIG. 9. Disconnect DataTrak

- Remove DataTrak module from bracket. See FIG. 10. Take module and attached cable to a non-hazardous location.

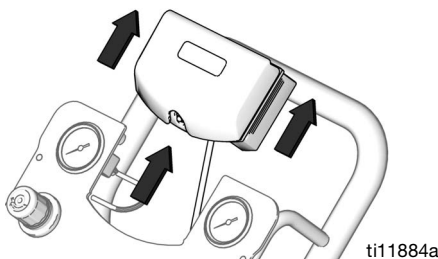

FIG. 10. Remove DataTrak

Replace Fuse

1. Remove the screw, metal strap, and plastic holder.
2. Pull the fuse away from the board.
3. Replace with an approved fuse from TABLE 3.

DataTrak Part Number	Series*	Fuse Required
289822	A or B	24C580
	C and later	24V216
All other part numbers	A	24C580
	B and later	24V216

* Fig 11 shows where to find the Series letter.

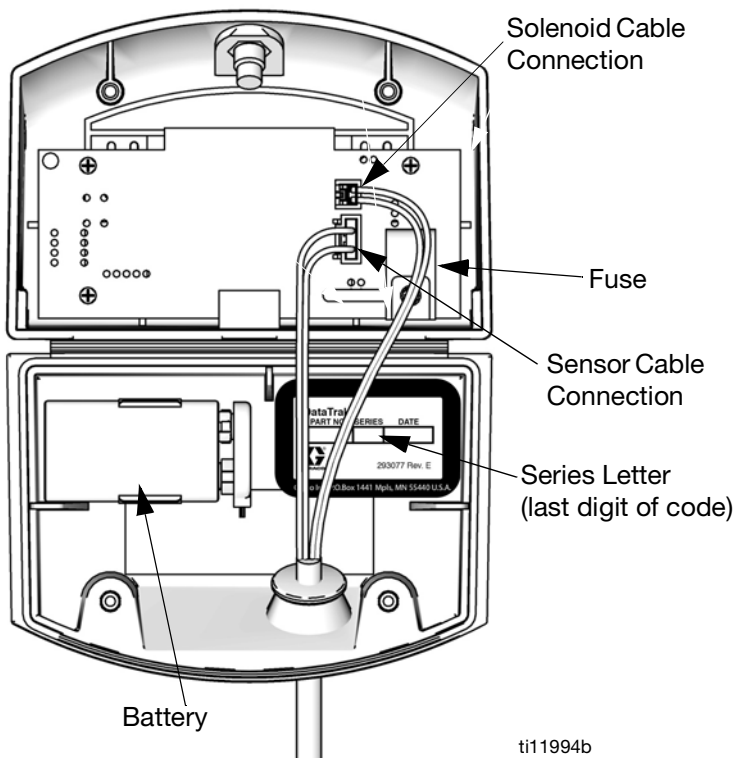

ti11994b

FIG. 11. DataTrak Battery and Fuse Location

Parts Cart Mount

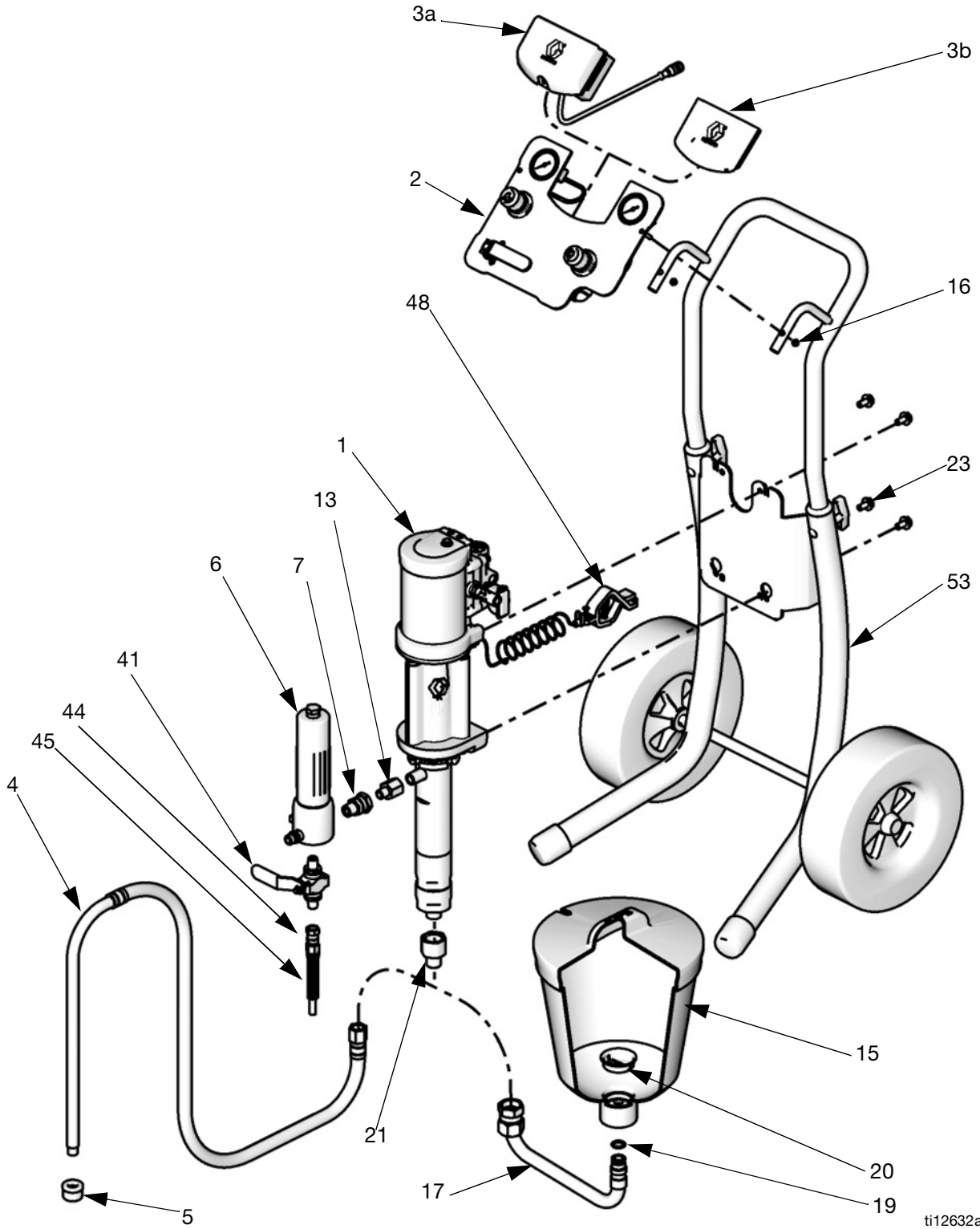

ti12632a

Stand Mount

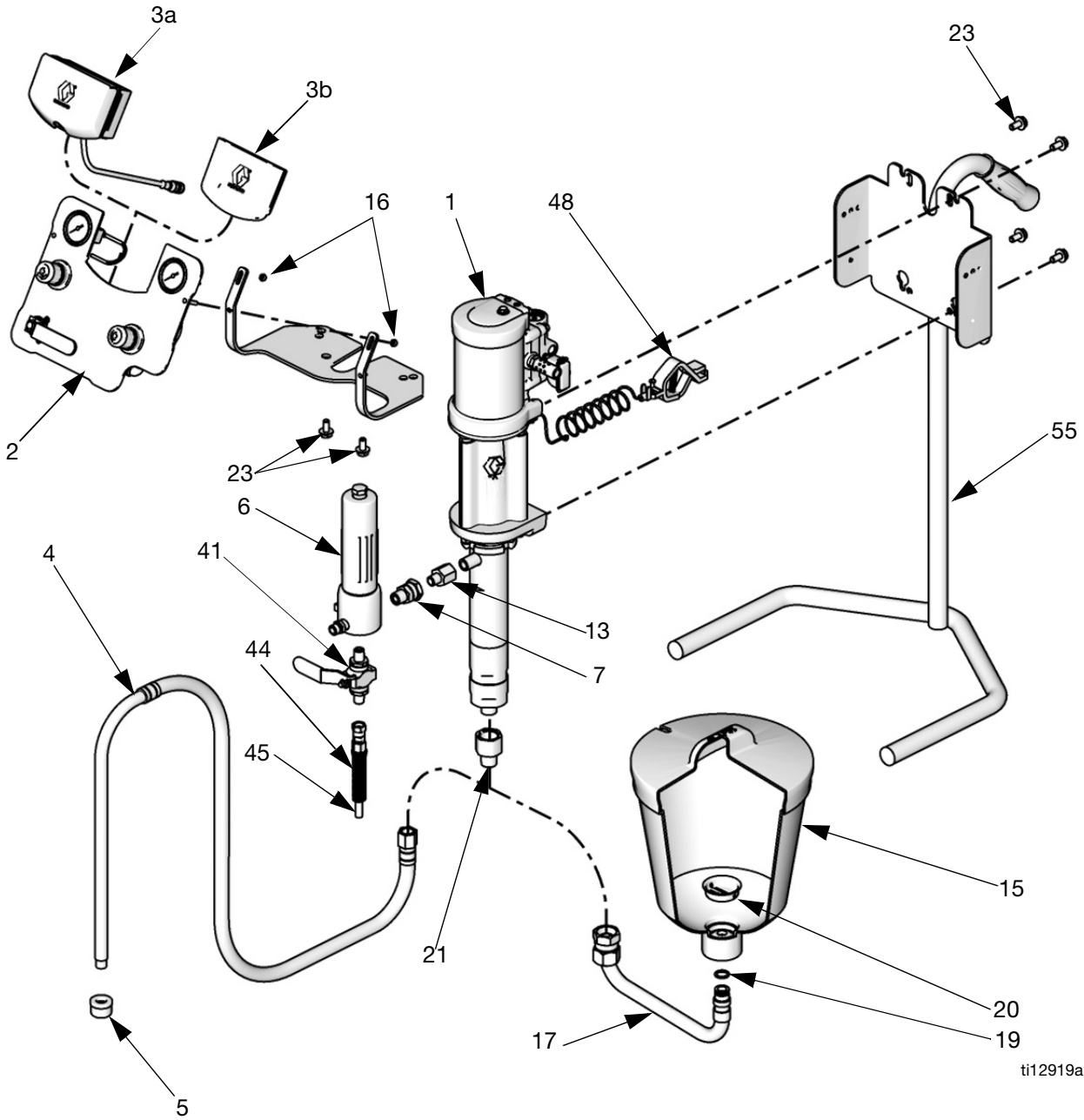

ti12919a

NOTE:

- See page 45 for mounting kits for all packages.
- See page 46 for repair parts and accessories.

Package	Parts List Page
G10xxx	35
G15xxx	36
G18xxx	37
G23xxx	38
G24xxx	39
G28xxx	40
G30xxx	41
G36xxx	42
G45xxx	43
G48xxx	44

G10xxx Models

This list includes all possible parts for G10xxx packages. See page 7 to check whether a part is included in your particular package.

Ref	Part	Description	Qty
1	W10CAS W10CBS	Pump Assembly; see <i>Manual 312794</i> M04LN0 x LW075A M04LT0 x LW075A	1
2	24A585	PANEL, air control; see <i>page 46</i>	1
3a	24A575	DATATRAK, assembly; see <i>manual 313541</i>	1
3b	-----	INSERT, panel (included with Part 2)	1
4	256420	HOSE, suction (includes Part 5)	1
5	-----	STRAINER (included with Part 4, or see <i>page 48 for packages of 10</i>)	1
6	24A587	FILTER, fluid	1
7	-----	FITTING, union, 3/8-18 npsm x 3/8-18 npt, (included with Part 6)	1
9	241812	HOSE, fluid (packages with gun)	1
10	26B501	GUN, PerformAA 15, GF, carbide, all G10xxx models except G10C15 and G10W11	1
	26B505	GUN, PerformAA 15, LV, carbide, models G10C15 and G10W11	
11	AXM413	TIP (packages with gun)	1
12	AXMxxx	TIP OPTION, (packages with gun)	1
13	512351	ADAPTER, outlet, 1/4 nptm x 3/8 nptf	1
14	256390	AIR HOSE, gun, (packages with gun)	1
15	256410	HOPPER (includes 17, 19, 20)	1
16	105332	NUT, lock, M5 x 0.08 (included with Parts 2 and 49)	2

Ref	Part	Description	Qty
17	-----	TUBE, inlet, hopper (included with Part 15)	1
18	-----	CLIP, hose (packages with gun), see <i>page 48 for packages of 10</i>	7
19	-----	O-RING, hopper (included with Part 15)	1
20	112133	SCREEN, hopper (included with Part 15)	1
21	24B299	ADAPTER, inlet, 3/4 nptf to 1/2 nptm, for suction hose	1
23	111799	SCREW, M8 x 16 (included with Parts 49, 53, and 54) Wall mount Cart mount	6 4
48	238909	WIRE, grounding assembly	1
49	24E883	BRACKET, air control, wall mount only (includes Parts 16 and 23)	1
53	See p. 45	CART MOUNTING KIT; see <i>page 45</i> (G10Cxx models only)	1
54	See p. 45	WALL MOUNTING KIT; see <i>page 45</i> (G10Wxx models only)	1

----- Not sold separately.

NOTE: Replacement Warning labels, signs, tags, and cards are available at no cost.

G15xxx Models

This list includes all possible parts for G15xxx packages. See page 8 to check whether a part is included in your particular package.

Ref.	Part	Description	Qty.
1	W15AAS W15BAS W15BBS W15FAS W15FBS	Pump Assembly; <i>see Manual 312794</i> M02LN0 x LW025A M04LN0 x LW050A M04LT0 x LW050A M12LN0 x LW150A M12LT0 x LW150A	1
2	24A585 24A583 24A581	PANEL, air controls (includes Part 3b) M02xxx or M04xxx motor, pump and gun; <i>see page 46</i> M12xxx motor, pump only; <i>see</i> <i>page 47</i> M12xxx motor, pump and gun; <i>see</i> <i>page 46</i>	1
3a	24A575 24A576	DATATRAK, assembly; <i>see manual</i> <i>313541</i> M02xxx and M04xxx motor M12xxx motor	1
3b	-----	INSERT, panel (included with Part 2)	1
4	256420 256422 256424	HOSE, suction (includes Part 5) LW025A or LW050A displacement pump LW150A displacement pump, cart mount LW150A displacement pump, wall mount	1
5	----- 187190	STRAINER (included with Part 4) LW025A or LW050A displacement pump, <i>see page 48 for packages of</i> <i>10</i> LW150A displacement pump	1
6	24A587	FILTER, fluid	1
7	-----	FITTING, union (included with Part 6)	1
9	241812	HOSE, fluid (packages with gun)	1
10	26B501 26B503	GUN, PerformAA 15, GF, carbide, all G15xxx models except G15C15, G15C17, G15W11, and G15W13 GUN, PerformAA 15, WL, carbide, models G15C15, G15C17, G15W11, and G15W13	1
11	AXM413	TIP (packages with AA gun)	1
12	AXMxxx	TIP OPTION (packages with AA gun)	1
13	512351 121238	ADAPTER, outlet LW025A or LW050A displacement pump, 1/4 nptm x 3/8 nptf LW150A displacement pump, 3/8 nptm x 3/4 nptf	1
14	256390	AIR HOSE, gun (all AA packages)	1
15	256410	HOPPER (includes 17, 19, 20, and 21)	1

Ref.	Part	Description	Qty.
16	105332	NUT, lock, M5 x 0.08 (included with Parts 2 and 49)	2
17	-----	TUBE, inlet, hopper (included with Part 15)	1
18	-----	CLIP, hose (all AA packages), <i>see page</i> <i>48 for packages of 10</i>	7
19	-----	O-RING, hopper (included with Part 15)	1
20	112133	SCREEN, hopper (included with Part 15)	1
21	----- 24B299	ADAPTER, 3/4 in. to 1/2 in. LW025A displacement pump with hopper (included with Part 15) LW050A or LW075A displacement pump with suction hose	1
22	26B598	HOSE, whip	1
23	111799	SCREW, M8 x 16 (included with Parts 49, 53, and 54) Wall and stand mount Cart mount	6 4
26	105335	SCREW (stand mount only)	1
37	166846	ADAPTER, for whip hose	1
48	238909	GROUNDING WIRE assembly	1
49	24E883	BRACKET, air control, wall and stand mount only (includes Parts 16 and 23)	1
53	289694	CART MOUNTING KIT; <i>see page 45</i> (G15Cxx models only)	1
54	24A578	WALL MOUNTING KIT; <i>see page 45</i> (G15Wxx models only)	1
55	24A577	STAND MOUNTING KIT; <i>see page 45</i> (G15Txx models only)	1

----- Not sold separately.

NOTE: Replacement Warning labels, signs, tags, and cards are available at no cost.

G18xxx Models

This list includes all possible parts for G18xxx packages. See page 9 to check whether a part is included in your particular package.

Ref.	Part	Description	Qty.
1	W18EAS W18EBS	Pump Assembly, see <i>Manual 312794</i> M12LN0 x LW125A M12LT0 x LW125A	1
2	24A583 24A581	PANEL, air controls (includes 3b) pump only; see <i>page 47</i> pump and gun; see <i>page 46</i>	1
3a	24A576	DATATRAK, assembly; see <i>manual 313541</i>	1
3b	-----	INSERT, panel (included with Part 2)	1
4	256422 256424	HOSE, suction (includes Part 5) cart mount packages wall mount packages	1
5	187190	STRAINER (included with Part 4)	1
6	24A587	FILTER, fluid	1
7	-----	FITTING, union (included with Part 6)	1
9	241812	HOSE, fluid (packages with gun)	1
10	25B511 26B518	GUN, PerformAA 50 GUN, PerformAA with RAC tip	1
11	AXM413	TIP, (packages with gun model 26B511)	1
12	AXMxxx	TIP OPTION (packages with gun model 26B511)	1
13	121237	ADAPTER, 3/8 nptm x 1/2 nptf	1

Ref.	Part	Description	Qty.
14	256390	AIR HOSE, gun (all AA packages)	1
16	105332	NUT, lock, M5 x 0.08 (included with Parts 2 and 49)	2
18	-----	CLIP, hose (all AA packages), see <i>page 48 for packages of 10</i>	7
22	26B598	HOSE, whip	1
23	111799	SCREW, M8 x 16 (included with Parts 49, 53, and 54) Wall mount Cart mount	6 4
37	166846	ADAPTER, for whip hose	1
48	238909	WIRE, grounding assembly	1
49	24E883	BRACKET, air control, wall mount only (includes Parts 16 and 23)	1
53	289694	CART MOUNTING KIT; see <i>page 45</i> (G18Cxx models only)	1
54	24A578	WALL MOUNTING KIT; see <i>page 45</i> (G18Wxx models only)	1

----- Not sold separately.

NOTE: Replacement Warning labels, signs, tags, and cards are available at no cost.

G23xxx Models

This list includes all possible parts for G23xxx packages. See page 10 to check whether a part is included in your particular package.

Ref.	Part	Description	Qty.
1	W23DAS W23DBS	Pump Assembly, <i>see Manual 312794</i> M12LN0 x LW100A M23LT0 x LW100A	1
2	24A583 24A581	PANEL, air controls (includes 3b) pump only; <i>see page 47</i> pump and gun; <i>see page 46</i>	1
3a	24A576	DATATRAK, assembly; <i>see manual 313541</i>	1
3b	-----	INSERT, panel (included with Part 2)	1
4	256421 256423	HOSE, suction (includes Part 5) cart mount packages wall mount packages	1
5	181073	STRAINER (included with Part 4)	1
6	24A587	FILTER, fluid	1
7	-----	FITTING, union (included with Part 6)	1
9	241812	HOSE, fluid (packages with gun)	1
10	XTR501 26B511 26B518	GUN XTR 5 PerformAA 50 PerformAA with RAC tip	1
11	AXM413	TIP (packages with PerformAA 50 gun)	1
12	AXMxxx	TIP OPTION (packages with PerformAA 50 gun)	1
13	512351	ADAPTER, 1/4 nptm x 3/8 nptf	1
14	256390	AIR HOSE, gun (all AA packages)	1
15	256410	HOPPER (includes Parts 17, 19, and 20)	1
16	105332	NUT, lock, M5 x 0.08 (included with Parts 2 and 49)	2

Ref.	Part	Description	Qty.
17	-----	TUBE, inlet, hopper (included with Part 15)	1
18	-----	CLIP, hose (all AA packages), <i>see page 48 for packages of 10</i>	7
19	-----	O-RING, hopper (included with Part 15)	1
20	112133	SCREEN, hopper (included with Part 15)	1
22	26B598	HOSE, whip	1
23	111799	SCREW, M8 x 16 (included with Parts 49, 53, and 54) Wall mount Cart mount	6 4
37	166846	ADAPTER, for whip hose	1
48	238909	WIRE, grounding assembly	1
49	24E883	BRACKET, air control, wall mount only (includes Parts 16 and 23)	1
53	289694	CART MOUNTING KIT; <i>see page 45</i> (G23Cxx models only)	1
54	24A578	WALL MOUNTING KIT; <i>see page 45</i> (G23Wxx models only)	1

----- Not sold separately.

NOTE: Replacement Warning labels, signs, tags, and cards are available at no cost.

G24xxx Models

This list includes all possible parts for G24xxx packages. See page 11 to check whether a part is included in your particular package.

Ref.	Part	Description	Qty.
1	W24FAS W24FBS	Pump Assembly, see <i>Manual 312794</i> M18LN0 x LW150A M18LT0 x LW150A	1
2	24A583 24A581	PANEL, air controls (includes Part 3b) pump only; see <i>page 47</i> pump and gun; see <i>page 46</i>	1
3a	24A576	DATATRAK, assembly; see <i>manual 313541</i>	1
3b	-----	INSERT, panel (included with Part 2)	1
4	256422 256424	HOSE, suction (includes Part 5) cart mount packages wall mount packages	1
5	187190	STRAINER (included with Part 4)	1
6	24A587	FILTER, fluid	1
7	-----	FITTING, union (included with Part 6)	1
9	241812	HOSE, fluid (packages with gun)	1
10	XTR501 26B511 26B518	GUN XTR 5 PerformAA 50 PerformAA with RAC tip	1
11	AXM413	TIP (Packages with PerformAA 50 gun)	1
12	AXMxxx	TIP OPTION (Packages with PerformAA gun)	1
13	121238	ADAPTER, 3/8 nptf x 3/4 nptm	1

Ref.	Part	Description	Qty.
14	256390	AIR HOSE, gun (all AA packages)	1
16	105332	NUT, lock, M5 x 0.08 (included with Parts 2 and 49)	2
18	-----	CLIP, hose (all AA packages), see <i>page 48 for packages of 10</i>	7
22	26B598	HOSE, whip	1
23	111799	SCREW, M8 x 16 (included with Parts 49, 53, and 54) Wall mount Cart mount	6 4
37	166846	ADAPTER, for whip hose	1
48	238909	WIRE, grounding assembly	1
49	24E883	BRACKET, air control, wall mount only (includes Parts 16 and 23)	1
53	289694	CART MOUNTING KIT; see <i>page 45</i> (G24Cxx models only)	1
54	24A578	WALL MOUNTING KIT; see <i>page 45</i> (G24Wxx models only)	1

----- Not sold separately.

NOTE: Replacement Warning labels, signs, tags, and cards are available at no cost.

G28xxx Models

This list includes all possible parts for G28xxx packages. See page 11 to check whether a part is included in your particular package.

Ref.	Part	Description	Qty.
1	W28EAS W28EBS	Pump Assembly, <i>see Manual 312794</i> M18LN0 x LW125A M18LT0 x LW125A	1
2	24A583 24A581	PANEL, air controls (includes Part 3b) pump only; <i>see page 47</i> pump and gun; <i>see page 46</i>	1
3a	24A576	DATATRAK, assembly; <i>see manual 313541</i>	1
3b	-----	INSERT, panel (included with Part 2)	1
4	256422 256424	HOSE, suction (includes Part 5) cart mount packages wall mount packages	1
5	187190	STRAINER (included with Part 4)	1
6	24A587	FILTER, fluid	1
7	-----	FITTING, union (included with Part 6)	1
9	241812	HOSE, fluid (packages with gun)	1
10	XTR501 26B511 26B518	GUN XTR 5 PerformAA 50 PerformAA with RAC tip	1
11	AXM413	TIP (Packages with AA gun)	1
12	AXMxxx	TIP OPTION (Packages with AA gun)	1
13	121237	ADAPTER, 3/8 nptm x 1/2 nptf	1

Ref.	Part	Description	Qty.
14	256390	AIR HOSE, gun (all AA packages)	1
16	105332	NUT, lock, M5 x 0.08 (included with Parts 2 and 49)	2
18	-----	CLIP, hose (all AA packages), <i>see page 48 for packages of 10</i>	7
22	26B598	HOSE, whip	1
23	111799	SCREW, M8 x 16 (included with Parts 49, 53, and 54) Wall mount Cart mount	6 4
37	166846	ADAPTER, for whip hose	1
48	238909	WIRE, grounding assembly	1
49	24E883	BRACKET, air control, wall mount only (includes Parts 16 and 23)	1
53	289694	CART MOUNTING KIT; <i>see page 45</i> (G28Cxx models only)	1
54	24A578	WALL MOUNTING KIT; <i>see page 45</i> (G28Wxx models only)	1

----- Not sold separately.

NOTE: Replacement Warning labels, signs, tags, and cards are available at no cost.

G30xxx Models

This list includes all possible parts for G30xxx packages. See page 12 to check whether a part is included in your particular package.

Ref.	Part	Description	Qty.
1	W30AAS W30ABS W30CAS W30CBS	Pump Assembly, <i>see Manual 312794</i> M04LN0 x LW025A M04LT0 x LW025A M12LN0 x LW075A M12LT0 x LW075A	1
2	24A586 24A585 24A583 24A581	PANEL, air controls (includes Part 3b) M04xxx motor, pump only, <i>see page 47</i> M04xxx motor, pump and gun; <i>see page 46</i> M12xxx motor, pump only; <i>see page 47</i> M12xxx motor, pump and gun; <i>see page 46</i>	1
3a	24A575 24A576	DATATRAK, assembly; <i>see manual 313541</i> M04xxx motors M12xxx motors	1
3b	-----	INSERT, panel (included with Part 2)	1
4	256420 24C581 256421 256423	HOSE, suction (includes Part 5) LW025A displacement pump G30C37 Model LW075A displacement pump, cart mount LW075A displacement pump, wall mount	1
5	----- 181073	STRAINER (included with Part 4) LW025A displacement pump, <i>see page 48 for packages of 10</i> LW075A displacement pump	1
6	24A587	FILTER, fluid, assembly (if included, uses parts 6a and 6b)	1
6a	24A587	FILTER, fluid, <i>see Manual 307273</i>	1
6b	-----	FITTING, union	1
9	H52525 24B562 241812	HOSE, fluid (packages with gun) G30W57–G30W60 G30C13, G30C57, G30C69 All other packages	1
10	XTR501 26B511 26B518	GUN XTR 5 PerformAA 50 PerformAA with RAC tip	1
11	AXM413	TIP (Packages with AA guns)	1
12	AXMxxx	TIP OPTION (Packages with AA guns)	1
13	512351	ADAPTER, 1/4 nptm x 3/8 nptf	1

Ref.	Part	Description	Qty.
14	256390	AIR HOSE, gun, 25 ft (7.6 m); used on most AA packages	1
	256389	AIR HOSE, gun, 50 ft (15.2 m); Model G30C69 only	1
15	256410	HOPPER (includes Parts 17, 19, and 20)	1
16	105332	NUT, lock, M5 x 0.08 (included with Parts 2 and 49)	2
17	-----	TUBE, inlet, hopper (included with Part 15)	1
18	-----	CLIP, hose (all AA packages), <i>see page 48 for packages of 10</i>	7
19	-----	O-RING, hopper (included with Part 15)	1
20	112133	SCREEN, hopper (included with Part 15)	1
21	-----	ADAPTER, 3/4 in. to 1/2 in., (LW025A only, included with Part 15)	1
22	26B598	HOSE, whip	1
23	111799	SCREW, M8 x 16 (included with Parts 49, 53, and 54) Wall and stand mount Cart mount	6 4
26	105335	SCREW (stand mount only)	1
37	166846	ADAPTER, for whip hose	1
41	256425	VALVE, drain, stainless steel (if equipped, includes Parts 44 and 45)	1
44	-----	COUPLING, hose, drain (included with Part 41)	1
45	-----	HOSE, drain (included with Part 41)	1
48	238909	GROUNDING WIRE assembly	1
49	24E883	BRACKET, air control, wall and stand mount only (includes Parts 16 and 23)	1
53	289694	CART MOUNTING KIT; <i>see page 45</i> (G30Cxx models only)	1
54	24A578	WALL MOUNTING KIT; <i>see page 45</i> (G30Wxx models only)	1
55	24A577	STAND MOUNTING KIT; <i>see page 45</i> (G30Txx models only)	1

----- Not sold separately.

NOTE: Replacement Warning labels, signs, tags, and cards are available at no cost.

G36xxx Models

This list includes all possible parts for G36xxx packages. See page 14 to check whether a part is included in your particular package.

Ref.	Part	Description	Qty.
1	W36DAS W36DBS	Pump Assembly, <i>see Manual 312794</i> M18LN0 x LW100A M18LT0 x LW100A	1
2	24A583 24A581	PANEL, air controls (includes Part 3b) pump only; <i>see page 47</i> pump and gun; <i>see page 46</i>	1
3a	24A576	DATATRAK, assembly; <i>see manual 313541</i>	1
3b	-----	INSERT, panel (included with Part 2)	1
4	256421 256423	HOSE, suction (includes Part 5) cart mount packages wall mount packages	1
5	181073	STRAINER (included with Part 4)	1
6	24A587	FILTER, fluid	1
7	-----	FITTING, union (included with Part 6)	1
9	H42525 24A412	HOSE, fluid (packages with gun) XTR 5 with RAC tip PerformAA 50 and PerformAA RAC	1
10	XTR504 26B511 26B518	GUN XTR 5 with RAC tip PerformAA 50 PerformAA with RAC tip	1
11	AXM413	TIP (packages with PerformAA 50 gun)	1
12	AXMxxx	TIP OPTION (packages with PerformAA 50 gun)	1
13	512351	ADAPTER, 1/4 nptm x 3/8 nptf	1
14	256390	AIR HOSE, gun, (all AA packages)	1
16	105332	NUT, lock, M5 x 0.08 (included with Parts 2 and 49)	2

Ref.	Part	Description	Qty.
18	-----	CLIP, hose (all AA packages), <i>see page 48 for packages of 10</i>	7
22	26B598	HOSE, whip (AA packages only)	1
23	111799	SCREW, M8 x 16 (included with Parts 49, 53, and 54) Wall mount Cart mount	6 4
37	166846	ADAPTER, for whip hose (AA pack- ages only)	1
41	256425	VALVE, drain, stainless steel (includes Parts 44 and 45)	1
44	-----	COUPLING, hose, drain (included with Part 41)	1
45	-----	HOSE, drain (included with Part 41)	1
48	238909	WIRE, grounding assembly	1
49	24E883	BRACKET, air control, wall mount only (includes Parts 16 and 23)	1
53	289694	CART MOUNTING KIT; <i>see page 45</i> (G36Cxx models only)	1
54	24A578	WALL MOUNTING KIT; <i>see page 45</i> (G36Wxx models only)	1

----- Not sold separately.

NOTE: Replacement Warning labels, signs, tags, and cards are available at no cost.

G45xxx Models

This list includes all possible parts for G45xxx packages. See page 15 to check whether a part is included in your particular package.

Ref.	Part	Description	Qty.
1	W45BAS W45BBS	Pump Assembly, see <i>Manual 312794</i> M12LN0 x LW050A M12LT0 x LW050A	1
2	24A583 24A581	PANEL, air controls (includes 3b) pump only, 100 psi; see <i>page 47</i> pump and gun, 100 psi; see <i>page 46</i>	1
3a	24A576	DATATRAK, assembly; see <i>manual 313541</i>	1
3b	-----	INSERT, panel (included with Part 2)	1
4	256421 256423	HOSE, suction (includes Part 5) cart mount packages wall mount packages	1
5	181073	STRAINER (included with Part 4)	1
6	24A587	FILTER, fluid	1
7	-----	FITTING, union (included with Part 6)	1
9	H42525 24A412	HOSE, fluid (packages with gun) XTR 5 with RAC tip PerformAA 50 and PerformAA with RAC tip	1
10	XTR504 26B511 26B518	GUN XTR 5 with RAC tip PerformAA 50 PerformAA with RAC tip	1
11	AXM413	TIP (packages with PerformAA 50 gun)	1
12	AXMxxx	TIP OPTION (packages with PerformAA 50 gun)	1
13	512351	ADAPTER, 1/4 nptm x 3/8 nptf	1
14	256390	AIR HOSE, gun, (all AA packages)	1
15	256410	HOPPER (includes Parts 17, 19, and 20)	1
16	105332	NUT, lock, M5 x 0.08 (included with Parts 2 and 49)	2

Ref.	Part	Description	Qty.
17	-----	TUBE, inlet, hopper (included with Part 15)	1
18	-----	CLIP, hose (all AA packages), see <i>page 48 for packages of 10</i>	7
19	-----	O-RING, hopper (included with Part 15)	1
20	112133	SCREEN, hopper (included with Part 15)	1
22	26B598	HOSE, whip (AA packages only)	1
23	111799	SCREW, M8 x 16 (included with Parts 49, 53, and 54) Wall mount Cart mount	6 4
37	166846	ADAPTER, for whip hose (AA pack- ages only)	1
38	-----	SWITCH, reed (included with Part 3a)	1
39	-----	SCREW, switch (included with Part 3a)	1
40	-----	CLAMP, hose (included with Part 3a)	2
41	256425	VALVE, drain, stainless steel (includes Parts 44 and 45)	1
44	-----	COUPLING, hose, drain (included with Part 41)	1
45	-----	HOSE, drain (included with Part 41)	1
48	238909	WIRE, grounding assembly	1
49	24E883	BRACKET, air control, wall mount only (includes Parts 16 and 23)	1
53	289694	CART MOUNTING KIT; see <i>page 45</i> (G45Cxx models only)	1
54	24A578	WALL MOUNTING KIT; see <i>page 45</i> (G45Wxx models only)	1

----- Not sold separately.

NOTE: Replacement Warning labels, signs, tags, and cards are available at no cost.

G48xxx Models

This list includes all possible parts for G48xxx packages. See page 16 to check whether a part is included in your particular package.

Ref.	Part	Description	Qty.
1	W48CAS W48CBS	Pump Assembly, <i>see Manual 312794</i> M18LN0 x LW075A M18LT0 x LW075A	1
2	24A583 24A581	PANEL, air controls (includes 3b, 16, 30, and 31) pump only, 100 psi; <i>see page 47</i> pump and gun, 100 psi, <i>see page</i> 46	1
3a	24A576	DATATRAK, assembly; <i>see manual</i> 313541	1
3b	-----	INSERT, panel (Included with Part 2)	1
4	256423	HOSE, suction (includes Part 5)	1
5	181073	STRAINER (included with Part 4)	1
6	24A587	FILTER, fluid	1
7	-----	FITTING, union (included with Part 6)	1
9	H52525 24A412	HOSE, fluid (packages with gun) XTR 5 with RAC tip PerformAA 50 and PerformAA with RAC tip	1
10	XTR504 26B511 26B518	GUN XTR 5 with RAC tip PerformAA 50 PerformAA with RAC tip	1
11	AXM413	TIP (packages with PerformAA 50 gun)	1
12	AXMxxx	TIP OPTION (packages with PerformAA 50 gun)	1
13	512351	ADAPTER, 1/4 nptm x 3/8 nptf	1
14	256390	AIR HOSE, gun (all AA packages)	1
15	256410	HOPPER (includes Parts 17, 19, and 20)	1
16	105332	NUT, lock, M5 x 0.08 (included with Parts 2 and 49)	2

Ref.	Part	Description	Qty.
17	-----	TUBE, inlet, hopper (included with Part 15)	1
18	-----	CLIP, hose (all AA packages), <i>see</i> <i>page 48 for packages of 10</i>	7
19	-----	O-RING, hopper (included with Part 15)	1
20	112133	SCREEN, hopper (included with Part 15)	1
22	26B598	HOSE, whip (AA packages only)	1
23	111799	SCREW, M8 x 16 (included with Parts 49, 53, and 54) Wall mount Cart mount	6 4
37	166846	ADAPTER, for whip hose (AA pack- ages only)	1
41	256425	VALVE, drain, stainless steel (includes Parts 44 and 45)	1
44	-----	COUPLING, hose, drain (included with Part 41)	1
45	-----	HOSE, drain (included with Part 41)	1
48	238909	WIRE, grounding assembly	1
49	24E883	BRACKET, air control, wall mount only (includes Parts 16 and 23)	1
53	289694	CART MOUNTING KIT; <i>see page 45</i> (G48Cxx models only)	1
54	24A578	WALL MOUNTING KIT; <i>see page 45</i> (G48Wxx models only)	1

----- Not sold separately.

NOTE: Replacement Warning labels, signs, tags, and cards are available at no cost.

Kits

Wall Mount Kit 24A578

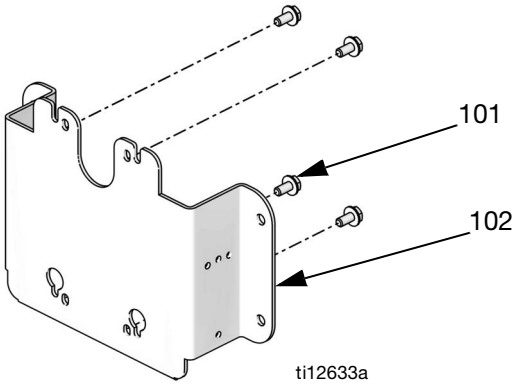

Ref.	Description	Qty
101	SCREW, cap, M8 x 1.25	4
102	PLATE, wall mount	1

NOTE: Air Control Mounting Kit 24E883 (see page 48) also is required for wall mounting a package that has a control panel.

Cart Mount Kit 289694

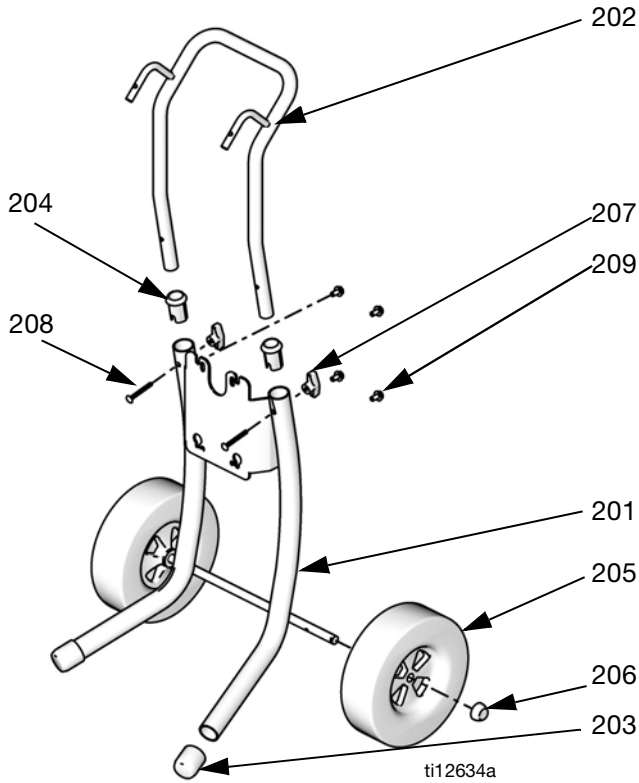

Ref.	Part	Description	Qty
201	----	CART, frame	1
202	----	HANDLE, cart	1
203	15C871	CAP, leg	2
204	----	SLEEVE, cart handle	2
205	119451	WHEEL, semi-pneumatic	2
206	119452	CAP, hub	2
207	115480	KNOB, t-handle	2
208	116630	SCREW, carriage	2
209	111799	SCREW, cap, M8 x 1.25	4

Stand Mount Kit 24A577

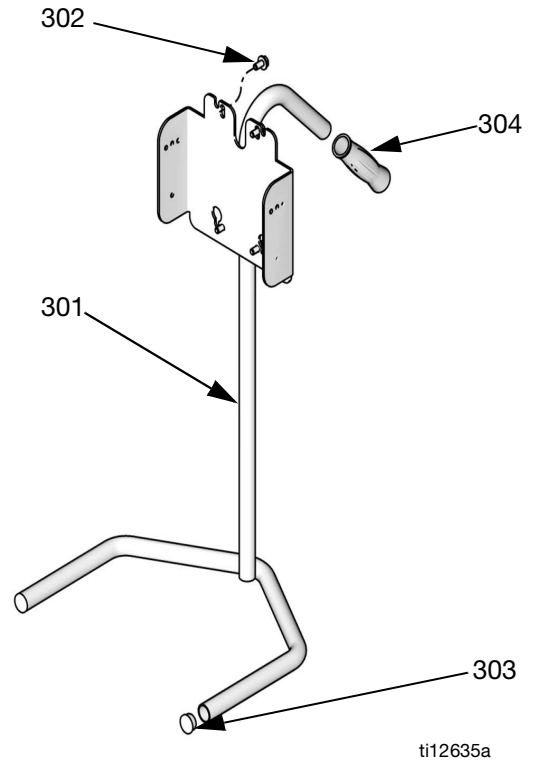

Ref.	Part	Description	Qty
301	----	FRAME	1
302	111799	SCREW, cap, M8 x 1.25	4
303	105521	PLUG, tubing	2
304	108063	GRIP, handle	1

NOTE: Air Control Mounting Kit 24E883 (see page 48) also is required for stand mounting a package that has a control panel.

Pump and Gun Control Panel Kits

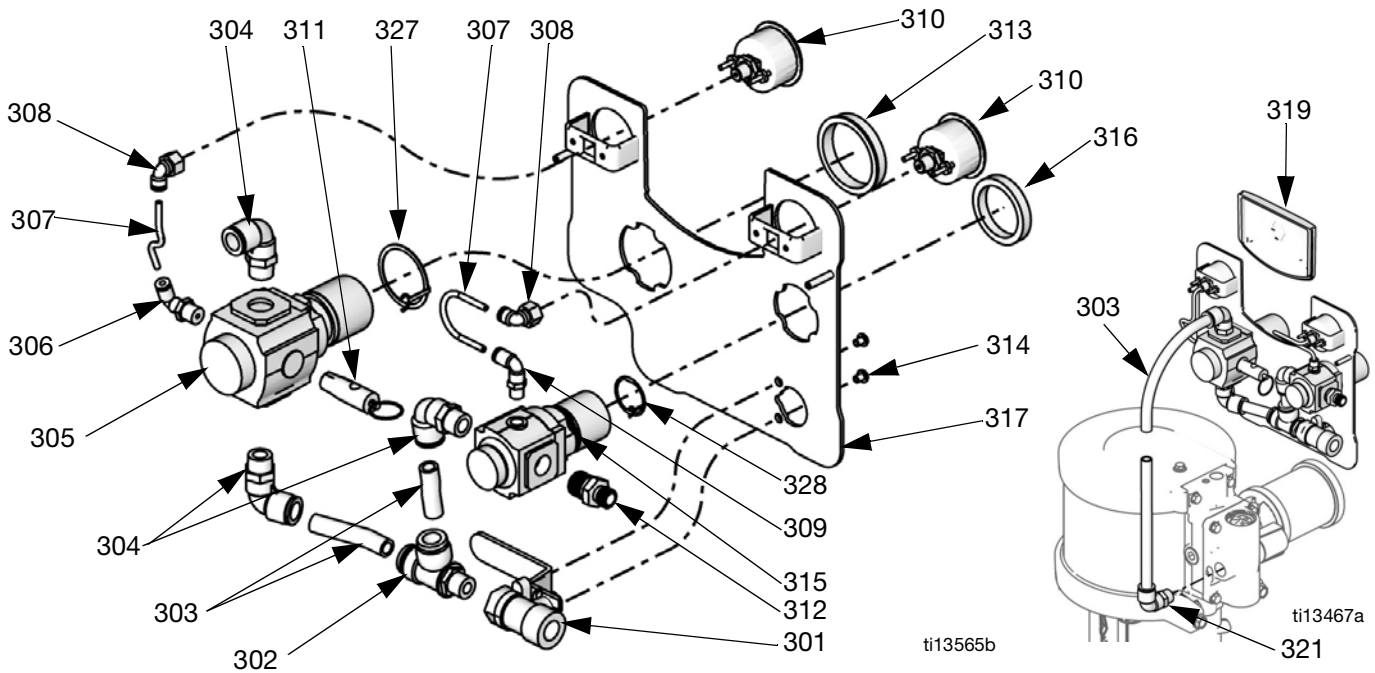

M12xxx and M18xxx air motors

Kits 24A581

Ref.	Part	Description	Qty.
301	114362	VALVE, ball	1
302	15T643	SWIVEL, tee, 3/8 npt(m) x 1/2T	1
303	-----	TUBE, 1/2 OD, cut to fit, order Tubing Kit 24D496	1.3 ft.
304	121212	ELBOW, swivel, 1/2T x 3/8 npt(m)	3
305	15T536	REGULATOR, air, pump, 3/8 npt	1
306	-----	ELBOW, swivel, 5/32 T x 1/4 npt	1
307*	-----	TUBE, black, cut to fit, order Tubing Kit 24D496	4 in.
308	15T498	SWIVEL, 90°, 5/32T x 1/8 npt(f)	2
309	15T866	ELBOW, swivel, 5/32T x 1/8 npt	1
310	15T500	GAUGE, pressure	2
311	113498	VALVE, safety	1
312	164672	ADAPTER	1
313	15T538	NUT, regulator	1
314	114381	SCREW, cap, button head	2
315	15T539	REGULATOR, air, gun, 3/8 npt	1
316	116514	NUT, regulator	1
317	-----	PANEL	1
318	-----	LABEL, panel (not shown)	1
319	-----	INSERT	1
320	105332	NUT, lock (not shown)	2
321	-----	ELBOW, 1/2T x 1/2 npt	1
322	-----	COVER, lens, 12 sticker sheet (not shown), order Kit 24A540 for 5 sheets	1
327	24P814	RING, grounding	1
328	24P813	RING, grounding	1

M02xxx and M04xxx air motors

Kit 24A585

Ref.	Part	Description	Qty.
301	114362	VALVE, ball, 3/8-18 npt(f)	1
302	-----	SWIVEL, tee	1
303	-----	TUBE, 3/8 OD, cut to fit, order Tubing Kit 24D496	1.3 ft.
304	121141	ELBOW, swivel, 3/8T x 1/4 npt(m)	3
305	15T499	REGULATOR, air, pump, 1/4 npt	1
306	15T866	ELBOW, swivel, 5/32T x 1/8 npt	1
307	-----	TUBE, black, cut to fit, order Tubing Kit 24D496	4 in.
308	15T498	SWIVEL, 90°, 5/32T x 1/8 npt(f)	2
309	15T866	ELBOW, swivel, 5/32T x 1/8 npt	1
310	15T500	GAUGE, pressure	2
311	113498	VALVE, safety	1
312	162453	ADAPTER, 1/4 nps(m) x 1/4 npt	1
313	115244	NUT, regulator	2
314	114381	SCREW, cap, button head	2
315	15T499	REGULATOR, air, gun, 1/4 npt	1
316	115244	NUT, regulator	1
317	-----	PANEL	1
318	-----	LABEL, panel (not shown)	1
319	-----	INSERT	1
320	105332	NUT, lock (not shown)	2
321	121141	ELBOW, 3/8T x 1/4 npt(m)	1
322	-----	COVER, lens, 12 sticker sheet (not shown), order Kit 24A540 for 5 sheets	1
323	-----	ELBOW, 1/4 npt(f) x 1/8 npt(m)	1
327	24P812	RING, grounding	1
328	24P812	RING, grounding	1

Pump Only Control Panel Kits

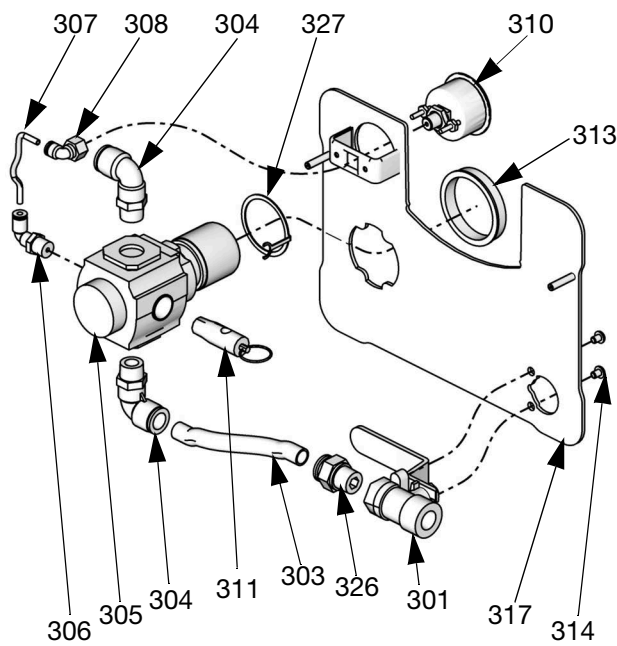

ti13567b

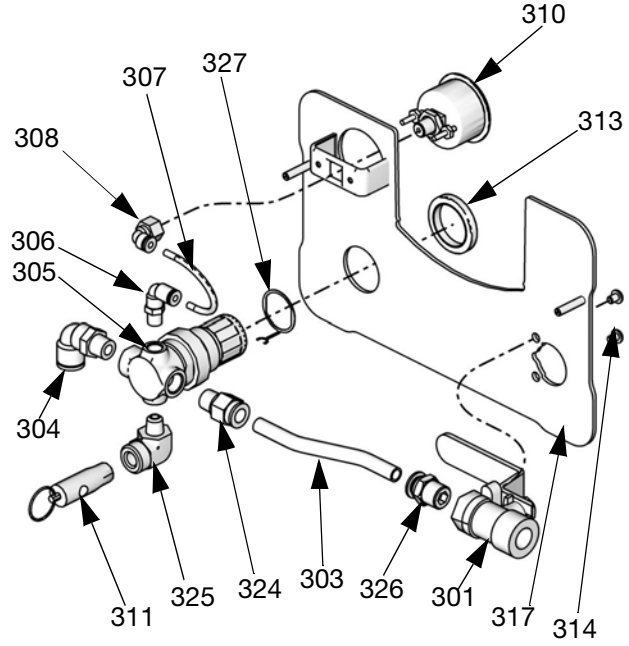

ti13566b

M07xxx, M12xxx, and M18xxx air motors

Kit 24A583

Ref. Part	Description	Qty.
301 114362	VALVE, ball	1
303 -----	TUBE, 1/2 OD, cut to fit, order Tubing Kit 24D496	1.5 ft.
304 121212	ELBOW, swivel, 1/2T x 3/8 npt(m)	2
305 15T536	REGULATOR, air, 3/8 npt	1
306 -----	ELBOW, swivel, 5/32 T x 1/4 npt	1
307 -----	TUBE, black, cut to fit, order Tubing Kit 24D496	5 in.
308 -----	SWIVEL, 90°, 5/32T x 1/8 npt(f)	1
310 15T500	GAUGE, pressure	1
311 113498	VALVE, safety	1
313 15T538	NUT, regulator	1
314 114381	SCREW, cap, button head	2
317 -----	PANEL	1
318 -----	LABEL, panel (not shown)	1
319 -----	INSERT (see inset illustration on page 46)	1
320 105332	NUT, lock (not shown)	2
321 -----	ELBOW, 1/2T x 1/2 npt (see inset illustration on page 46)	1
322 -----	COVER, lens, 12 sticker sheet (not shown), order Kit 24A540 for 5 sheets	1
326 -----	FITTING, straight, 1/2T x 3/8 npt(m)	1
327 24P814	RING, grounding	1

M02xxx and M04xxx air motors

Kit 24A586

Ref. Part	Description	Qty.
301 114362	VALVE, ball	1
303 -----	TUBE, 3/8 OD, cut to fit, order Tubing Kit 24D496	1.3 ft.
304 121141	ELBOW, swivel, 3/8T x 1/4 npt(m)	1
305 15T499	REGULATOR, air, 1/4 npt	1
306 15T866	ELBOW, swivel, 5/32T x 1/8 npt	1
307 -----	TUBE, black, cut to fit, order Tubing Kit 24D496	4 in.
308 15T498	SWIVEL, 90°, 5/32T x 1/8 npt(f)	1
310 15T500	GAUGE, pressure	1
311 113498	VALVE, safety	1
313 115244	NUT, regulator	1
314 114381	SCREW, cap, button head	2
317 -----	PANEL	1
318 -----	LABEL, panel (not shown)	1
319 -----	INSERT (see inset illustration on page 46)	1
320 105332	NUT, lock (not shown)	2
321 121141	ELBOW, swivel, 3/8T x 1/4 npt(m) (see inset illustration on page 46)	1
322 -----	COVER, lens, 12 sticker sheet (not shown), order Kit 24A540 for 5 sheets	1
324 -----	FITTING, straight, 3/8T x 1/4 npt(m)	1
325 -----	ELBOW, 1/4 npt(f) x 1/8 npt(m)	1
326 -----	FITTING, straight, 3/8T x 3/8 npt(m)	1
327 24P812	RING, grounding	1

DataTrak

NOTE: See DataTrak manual, 313541, for all DataTrak related part numbers and kit information, including the reed switch and solenoid.

Hopper Kit 256410

Includes hopper (15), inlet tube (17), o-ring (19), screen (20), and fitting (21, 25cc pumps only).

Air Control Mounting Kit 24E883, Wall and Stand

Kit 24E883 includes bracket (49), two hex nuts (16), and two screws (23). Use either set of mounting holes.

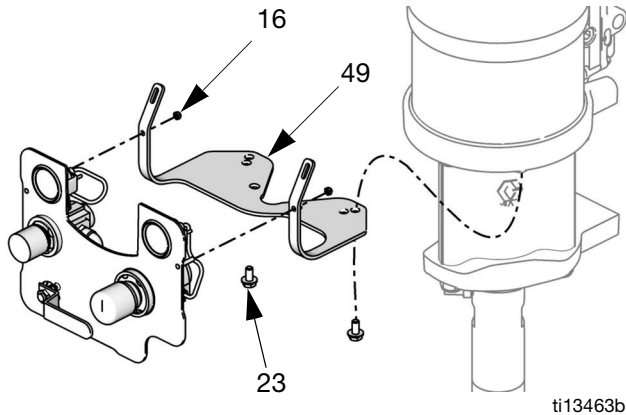

5-Gallon Suction Hose Kits

Includes suction hose (4) and strainer (5).

Kit	Packages	Wall/Cart
256420	10:1, 15:1, 30:1 -- M02xxx and M04xxx air motors only	Both
256421	23:1, 30:1 (M12xxx X L075xx), 36:1, 45:1, 48:1	Cart
256422	15:1 (M12xxx X L150xx), 18:1, 24:1, 28:1	Cart
256423	23:1, 30:1 (M12xxx X L075xx), 36:1, 45:1, 48:1	Wall
256424	15:1 (M12xxx X L150xx), 18:1, 24:1, 28:1	Wall

256426 - Package of 10 strainers (5) for Kit 256420.

55-Gallon Suction Hose Kits

Includes suction hose, bung adapter, and strainer.

24A954 - 3/4 in. hose

24B598 - 1 in. hose

PTFE Suction Hose Kits

For pumping acid materials that are compatible with PTFE. Includes suction hose, swivel, and strainer.

Kit	Description	Wall/Cart
24B337	3/4 in. hose, PTFE lined, with swivel elbow	Cart
24B338	1 in. hose, PTFE lined, with swivel elbow	Cart
24B424	3/4 in. hose, PTFE lined, with straight swivel	Wall
24B425	1 in. hose, PTFE lined, with straight swivel	Wall
24J315	3/8 in. hose, 1/2 in. connection, PTFE lined, with straight swivel	Wall or Cart*

* Cart mount requires separate fitting, Part Number 114874.

Drain Valve Kit 256425

Includes drain valve (41), coupling (44), and hose (45).

Reinforced PTFE V-Packing Kits

NOTE: See manual 312792 for information related to optional kits with reinforced PTFE seals for use with materials that cause chemical compatibility concerns with UHMWPE, such as acid catalyst materials.

Guns and Hoses

To find the correct parts for your model, locate the gun you have. The correct hoses and related parts are listed in the table below each gun.

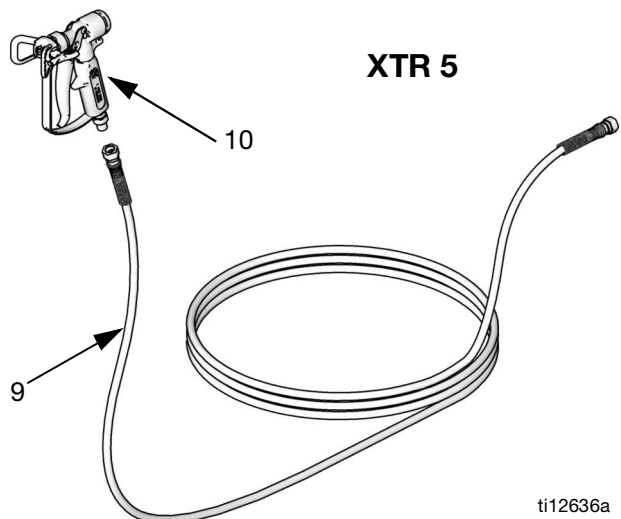

Ref. Part	Description	Qty.
9	HOSE, fluid	1
241812	G10xxx-G30xxx; exceptions listed next in this table; 25 ft (7.6 m), 3300 psi (22.7 MPa, 227 bar) maximum working pressure	
H52525	G30W57-G30W60, G48xxx; 25 ft (7.6 m), 5600 psi (38.6 MPa, 386 bar) maximum working pressure	
24B562	G30C13 and G30C57; 50 ft (15.2 m), 3300 psi (22.7 MPa, 227 bar) maximum working pressure	
H42525	G36xxx-G45xxx; 25 ft (7.6 m); 4500 psi (30.1 MPa, 310 bar) maximum working pressure	
10	XTR501 GUN, XTR	1
XTR504	GUN, XTR with RAC tip	1

ti12636a

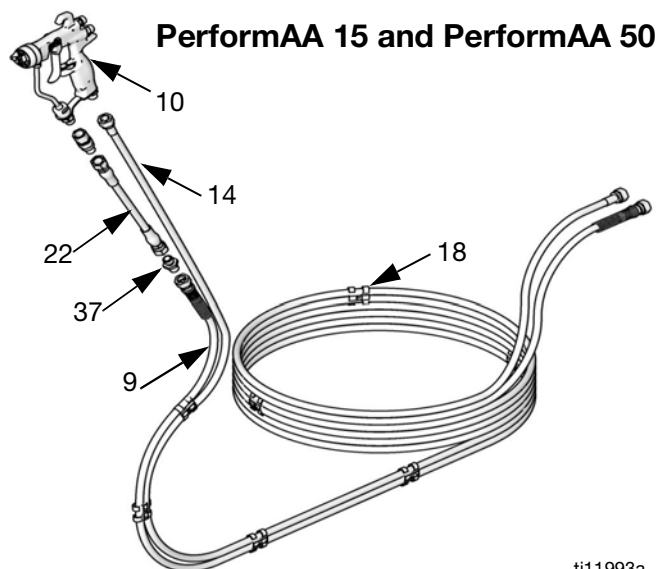

ti11993a

Ref. Part	Description	Qty.
9	HOSE, fluid	1
241812	G10xxx-G30xxx, 25 ft (7.6 m), 3300 psi (22.7 MPa, 227 bar) maximum working pressure	
24A446	G36xxx, 23 ft (7 m); 4100 psi (28.3 MPa, 283 bar) maximum working pressure	
24A412	G45xxx - G48xxx, 25 ft (7.6 m), 5600 psi (38.6 MPa, 345 bar), maximum working pressure	
10	26B511 GUN, PerformAA 50	1
26B518	GUN, PerformAA with RAC tip	
26B501	GUN, PerformAA 15, GF, carbide	
26B503	GUN, PerformAA 15, WL, carbide	
26B505	GUN, PerformAA 15, LV, carbide	
11	AXM413 TIP	1
12	AXMxxx TIP, option, see gun manual	1
14	256390 HOSE, air	1
18	----- CLIP, hose; order Kit 24A588 for package of 10	7
22	26B598 HOSE, whip, G36xxx, packages only	1
26B598	HOSE, whip, G45xxx- G48xxx	
37	166846 ADAPTER, for whip hose	1

50-Foot Air/Fluid Hose Kit 24A955

Optional 50-foot coupled fluid/air hose with 20 clips. Use with G10xxx-G30xxx models only (3300 psig maximum fluid working pressure).

50-Foot Fluid Hose 24A413

Optional 50-foot hose, 5600 psi (38.6 MPa, 386 bar) maximum working pressure.

Wall Bracket Mounting Dimensions

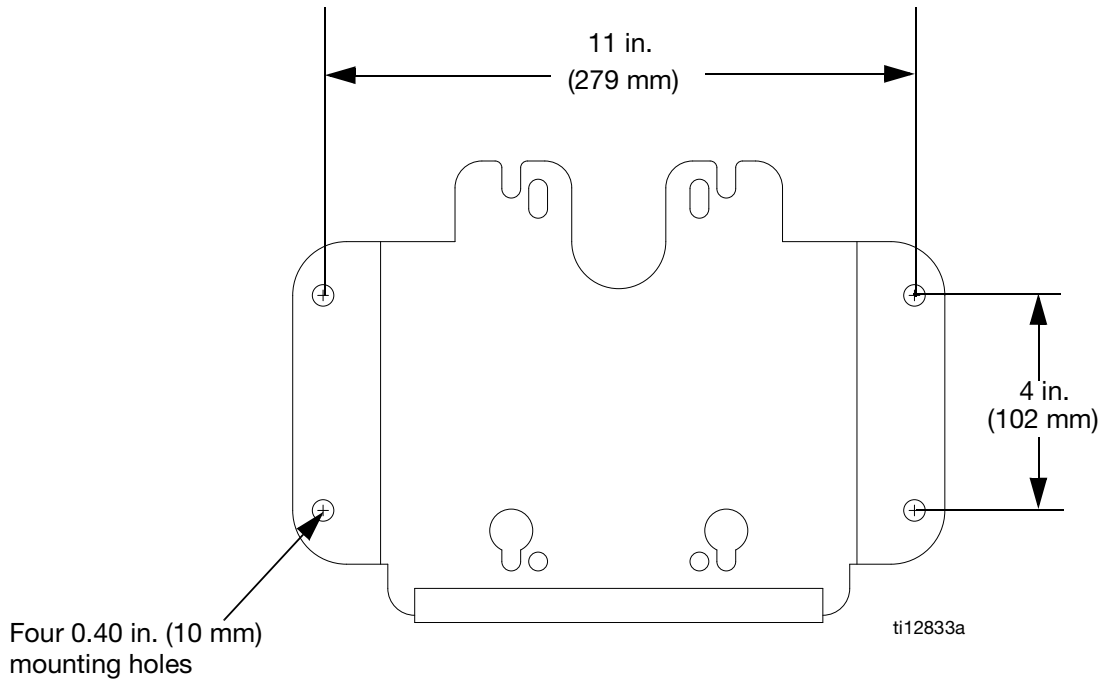

Technical Data

Maximum fluid working pressure	See Models table on page 6.
Maximum pump air inlet pressure	100 psi (0.7 MPa, 7.0 bar)
Maximum gun air inlet pressure	100 psi (0.7 MPa, 7.0 bar)
Ratio	See Models table on page 6.
Air inlet size	3/8-18 npt(f)
Ambient air temperature range	35°F–120°F (2°C–49°C)
Maximum fluid temperature	160°F (71°C)
Sound data	See Technical Data in air motor manual 312796.
Wetted parts	Displacement pump: Stainless steel, tungsten carbide with 6% nickel, UHMWPE, PTFE Spray gun: See Manual 3A8099 (PerformAA guns) or Manual 312145 (XTR guns). Fluid hoses: nylon Suction assembly: stainless steel, nylon Fluid filter: See manual 307273. Drain valve: stainless steel, nylon

Package Weights

Ratio, Motor, Displacement Pump	Weight in lb (kg)				
	Mounted Pump*	Mounted pump* + siphon kit	Mounted pump + siphon kit + fluid filter	Mounted pump* + siphon kit or hopper + gun and hoses	Mounted pump* + siphon kit or hopper + gun and hoses + fluid filter
Cart Mount					
10:1, M04xxx, LW075A	68 (31)	69 (32)	----	76 (35)	81 (37)
15:1, M02xxx, LW025A	53 (24)	54 (25)	----	62 (29)	67 (31)
15:1, M04xxx, LW050A	66 (30)	67 (31)	----	75 (34)	79 (36)
15:1, M12xxx, LW150A	100 (45)	103 (47)	109 (49)	-----	113 (51)
18:1, M12xxx, LW125A	100 (45)	104 (47)	109 (49)	-----	113 (51)
23:1, M12xxx, LW100A	98 (45)	101 (46)	105 (48)	-----	111 (50)
24:1, M18xxx, LW150A	102 (46)	-----	111 (50)	-----	116 (53)
28:1, M18xxx, LW125A	102 (46)	-----	111 (50)	-----	116 (53)
30:1, M04xxx, LW025A	60 (28)	61 (28)	-----	68 (31)	73 (34)
30:1, M12xxx, LW075A	94 (43)	98 (45)	104 (47)	-----	108 (49)
36:1, M18xxx, LW100A	100 (45)	-----	108 (49)	-----	114 (52)
45:1, M12xxx, LW050A	92 (42)	96 (43)	101 (46)	101 (46)	106 (48)
48:1, M18xxx, LW075A	97 (44)	-----	105 (48)	106 (48)	110 (50)
Wall Mount					
10:1, M04xxx, LW075A	42 (19)	43 (20)	-----	48 (22)	53 (24)
15:1, M02xxx, LW025A	27 (12)	28 (13)	-----	33 (15)	38 (17)
15:1, M04xxx, LW050A	40 (18)	41 (19)	-----	46 (21)	51 (23)
15:1, M12xxx, LW150A	73 (33)	-----	81 (37)	-----	86 (39)
18:1, M12xxx, LW125A	72 (33)	-----	81 (37)	-----	86 (39)
23:1, M12xxx, LW100A	70 (32)	-----	78 (35)	-----	83 (38)
24:1, M18xxx, LW150A	76 (35)	-----	84 (38)	-----	89 (40)
28:1, M18xxx, LW125A	75 (34)	-----	83 (38)	-----	87 (39)
30:1, M04xxx, LW025A	34 (15)	35 (16)	-----	40 (18)	44 (20)
30:1, M12xxx, LW075A	67 (30)	-----	75 (34)	-----	80 (36)
36:1, M18xxx, LW100A	73 (33)	-----	81 (37)	-----	87 (39)
45:1, M12xxx, LW050A	65 (29)	-----	73 (33)	-----	80 (36)
48:1, M18xxx, LW075A	70 (32)	-----	78 (35)	-----	84 (38)
Stand Mount					
15:1, M02xxx, LW025A	29 (13)	30 (14)	-----	36 (16)	41 (19)
30:1, M04xxx, LW025A	36 (16)	37 (17)	-----	43 (20)	48 (22)
15:1, M04xxx, LW050A	42 (19)	43 (20)	-----	49 (22)	54 (25)

* Includes air controls.

----- This component configuration is not offered for these models.

California Proposition 65

CALIFORNIA RESIDENTS

 **WARNING:** Cancer and reproductive harm – www.P65warnings.ca.gov.

Graco Standard Warranty

Graco warrants all equipment referenced in this document which is manufactured by Graco and bearing its name to be free from defects in material and workmanship on the date of sale to the original purchaser for use. With the exception of any special, extended, or limited warranty published by Graco, Graco will, for a period of twelve months from the date of sale, repair or replace any part of the equipment determined by Graco to be defective. This warranty applies only when the equipment is installed, operated and maintained in accordance with Graco's written recommendations.

This warranty does not cover, and Graco shall not be liable for general wear and tear, or any malfunction, damage or wear caused by faulty installation, misapplication, abrasion, corrosion, inadequate or improper maintenance, negligence, accident, tampering, or substitution of non-Graco component parts. Nor shall Graco be liable for malfunction, damage or wear caused by the incompatibility of Graco equipment with structures, accessories, equipment or materials not supplied by Graco, or the improper design, manufacture, installation, operation or maintenance of structures, accessories, equipment or materials not supplied by Graco.

This warranty is conditioned upon the prepaid return of the equipment claimed to be defective to an authorized Graco distributor for verification of the claimed defect. If the claimed defect is verified, Graco will repair or replace free of charge any defective parts. The equipment will be returned to the original purchaser transportation prepaid. If inspection of the equipment does not disclose any defect in material or workmanship, repairs will be made at a reasonable charge, which charges may include the costs of parts, labor, and transportation.

THIS WARRANTY IS EXCLUSIVE, AND IS IN LIEU OF ANY OTHER WARRANTIES, EXPRESS OR IMPLIED, INCLUDING BUT NOT LIMITED TO WARRANTY OF MERCHANTABILITY OR WARRANTY OF FITNESS FOR A PARTICULAR PURPOSE.

Graco's sole obligation and buyer's sole remedy for any breach of warranty shall be as set forth above. The buyer agrees that no other remedy (including, but not limited to, incidental or consequential damages for lost profits, lost sales, injury to person or property, or any other incidental or consequential loss) shall be available. Any action for breach of warranty must be brought within two (2) years of the date of sale.

GRACO MAKES NO WARRANTY, AND DISCLAIMS ALL IMPLIED WARRANTIES OF MERCHANTABILITY AND FITNESS FOR A PARTICULAR PURPOSE, IN CONNECTION WITH ACCESSORIES, EQUIPMENT, MATERIALS OR COMPONENTS SOLD BUT NOT MANUFACTURED BY GRACO. These items sold, but not manufactured by Graco (such as electric motors, switches, hose, etc.), are subject to the warranty, if any, of their manufacturer. Graco will provide purchaser with reasonable assistance in making any claim for breach of these warranties.

In no event will Graco be liable for indirect, incidental, special or consequential damages resulting from Graco supplying equipment hereunder, or the furnishing, performance, or use of any products or other goods sold hereto, whether due to a breach of contract, breach of warranty, the negligence of Graco, or otherwise.

FOR GRACO CANADA CUSTOMERS

The Parties acknowledge that they have required that the present document, as well as all documents, notices and legal proceedings entered into, given or instituted pursuant hereto or relating directly or indirectly hereto, be drawn up in English. Les parties reconnaissent avoir convenu que la rédaction du présente document sera en Anglais, ainsi que tous documents, avis et procédures judiciaires exécutés, donnés ou intentés, à la suite de ou en rapport, directement ou indirectement, avec les procédures concernées.

Graco Information

For the latest information about Graco products, visit www.graco.com.

For patent information, see www.graco.com/patents.

TO PLACE AN ORDER, contact your Graco distributor or call to identify the nearest distributor.

Phone: 612-623-6921 **or Toll Free:** 1-800-328-0211 **Fax:** 612-378-3505

All written and visual data contained in this document reflects the latest product information available at the time of publication. Graco reserves the right to make changes at any time without notice.

Original instructions. This manual contains English. MM 312797

Graco Headquarters: Minneapolis

International Offices: Belgium, China, Japan, Korea

GRACO INC. AND SUBSIDIARIES • P.O. BOX 1441 • MINNEAPOLIS MN 55440-1441 • USA
Copyright 2008, Graco Inc. All Graco manufacturing locations are registered to ISO 9001.

www.graco.com

Revision ZAD, May 2022