

Air Controls for Therm-O-Flow®

334201F

EN

Repair Kit for Integrated Air Controls for Therm-O-Flow® 20 and 200 Systems. For professional use only.

Part No. 24W870



Important Safety Instructions

Read all warnings and instructions in this manual and in all related manuals. Save all instructions.

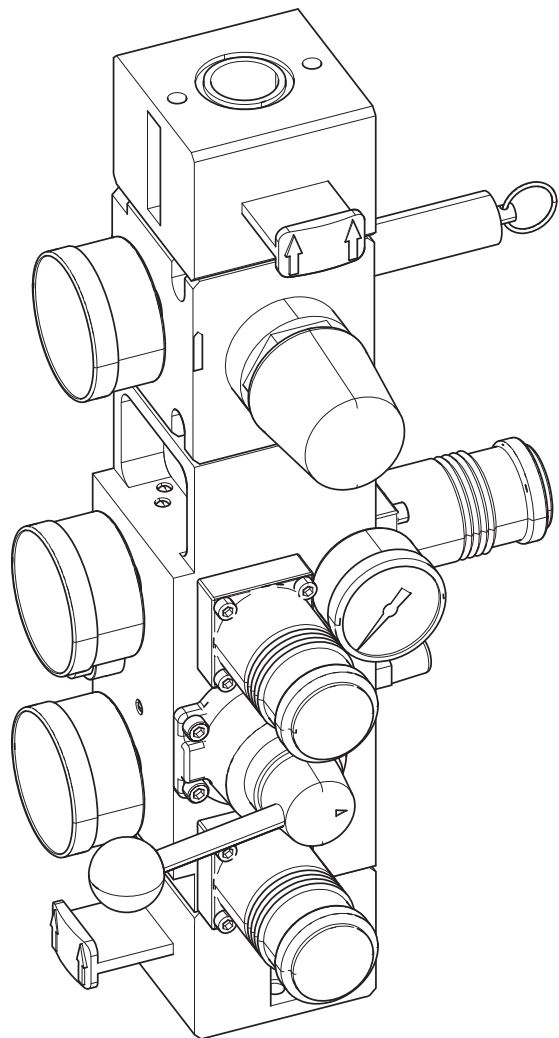

ti25387a

Contents

- Models** **3**
- Related Manuals** **3**
- Repair** **4**
 - Pressure Relief 4
 - Remove the Air Control 4
 - Replace the Director Valve 4
 - Replace the Air Motor Regulator 5
 - Replace the Air Regulators 5
- Parts** **6**
 - 24W870 Air Control 6
- Graco Information** **8**

Models

Kit	Maximum Working Pressure psi (MPa, bar)	Description	Air Inlet Size
24W870	125 psi (0.8 MPa, 8.6 bar)	Integrated Air Controls for Therm-O-Flow 20 and Therm-O-Flow 200	3/4 npt (f)





Related Manuals

Manual	Description
334129	Therm-O-Flow 200, Instructions-Parts
334130	Therm-O-Flow 20, Instructions-Parts

Repair

Pressure Relief

WARNING

PRESSURIZED FLUID HAZARD

Therm-O-Flow equipment stays pressurized until pressure is manually relieved. To help prevent serious injury from pressurized fluid, such as skin injection, splashing fluid and moving parts, follow the Pressure Relief Procedure when you stop pumping and before cleaning, checking or servicing the equipment.

Relieve pressure by following the Pressure Relief Procedure in the instruction manual for the Therm-O-Flow system you are using. See **Related Manuals** on page 3.

Remove the Air Control

1. Relieve pressure to the Therm-O-Flow system.
2. Disconnect all hoses and tubing from the air control.
3. Remove the four screws and washers as shown in Figure 1.

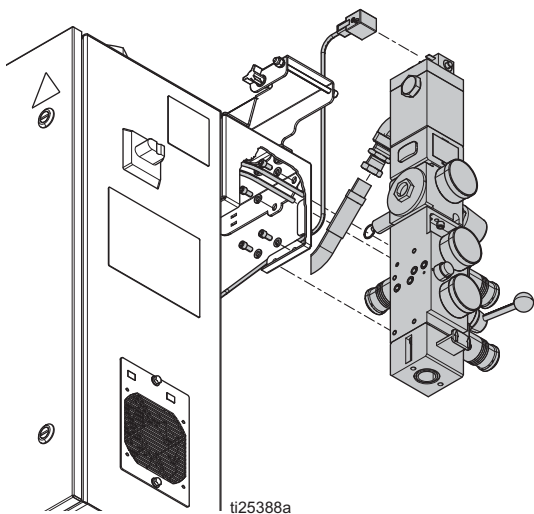

FIG. 1: Air Control Removal

Replace the Director Valve

1. Relieve pressure to the Therm-O-Flow system.
2. Remove screws (5a) as shown in Figure 2 and take off the director valve.
3. Remove the spring (5c), valve plate (5d), and o-ring (5b).

NOTE: Note the orientation of the director valve plate when you remove it. The opening should be on the opposite side (left) of the lever.

4. Remove and discard the pin (5g) and the four valve seats (5e) with the o-rings (5f).
5. Insert new valve seats (5e) with o-rings (5f) and the new pin (5g).
6. Insert the new director valve plate (5d; see the note above), spring (5c), and o-ring (5b).
7. Attach the new director valve plate with the screws (5a). Tighten the screws until snug.

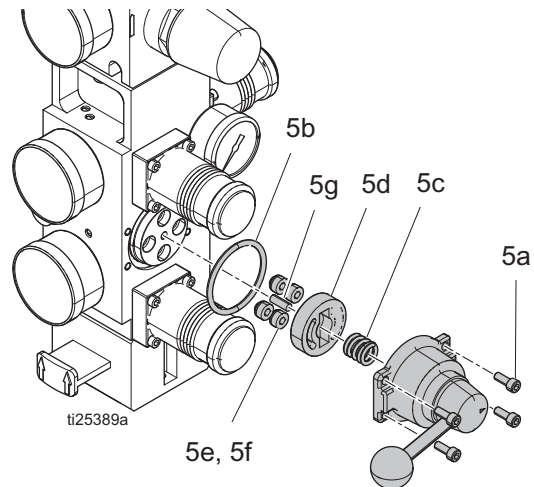

FIG. 2: Director Valve Replacement

Replace the Air Motor Regulator

1. Relieve pressure to the Therm-O-Flow system.
2. Disconnect the air motor housing and fittings.
3. Remove the two screws (9) and take off the shutoff valve (1) at the top of the module. If your system has an air solenoid, it can remain attached to the shutoff valve.
4. Remove the two screws (9) and take off the air motor regulator (6).
5. Attach the new regulator (6) to the manifold. Orient it so the gauge lines up with the ram gauges and the direction of the flow arrow points up. Tighten the screws until snug. It is recommended that you use thread locker Loctite 220 or equivalent.
6. Reattach the shutoff valve (1) at the top of the regulator. Make sure that the o-ring (3) is in place on the valve (1).

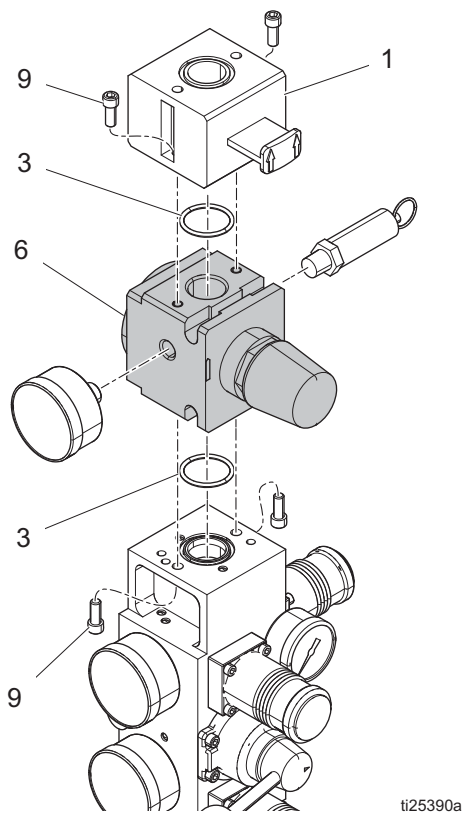

FIG. 3: Air Motor Regulator Replacement

Replace the Air Regulators

Identify which knob regulator (8) need to be replaced.

- Ram Down Air Regulator (CB)
- Ram Up Air Regulator (CD)
- Blowoff Air Regulator (CJ)

1. Relieve pressure to the Therm-O-Flow system.
2. Remove the four screws (8a) and take off the air regulator (8) as shown in Figure 4.
3. Replace the o-rings (8b) on the back side of the regulator.
4. Attach the new air regulator to the manifold. Use the index pin for correct orientation. Tighten the screws until snug.

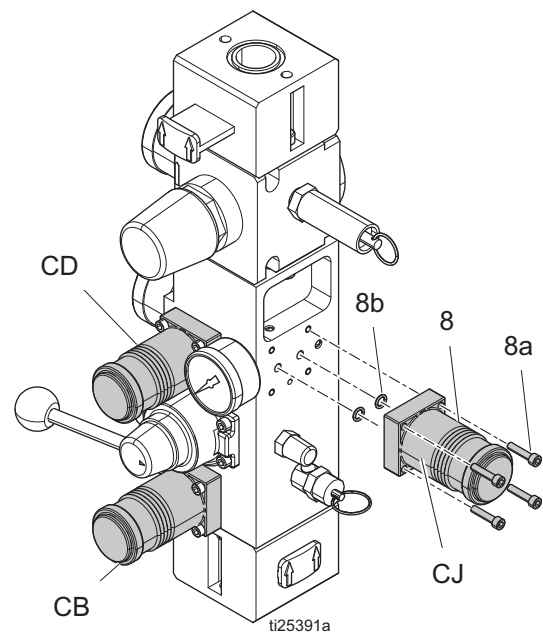
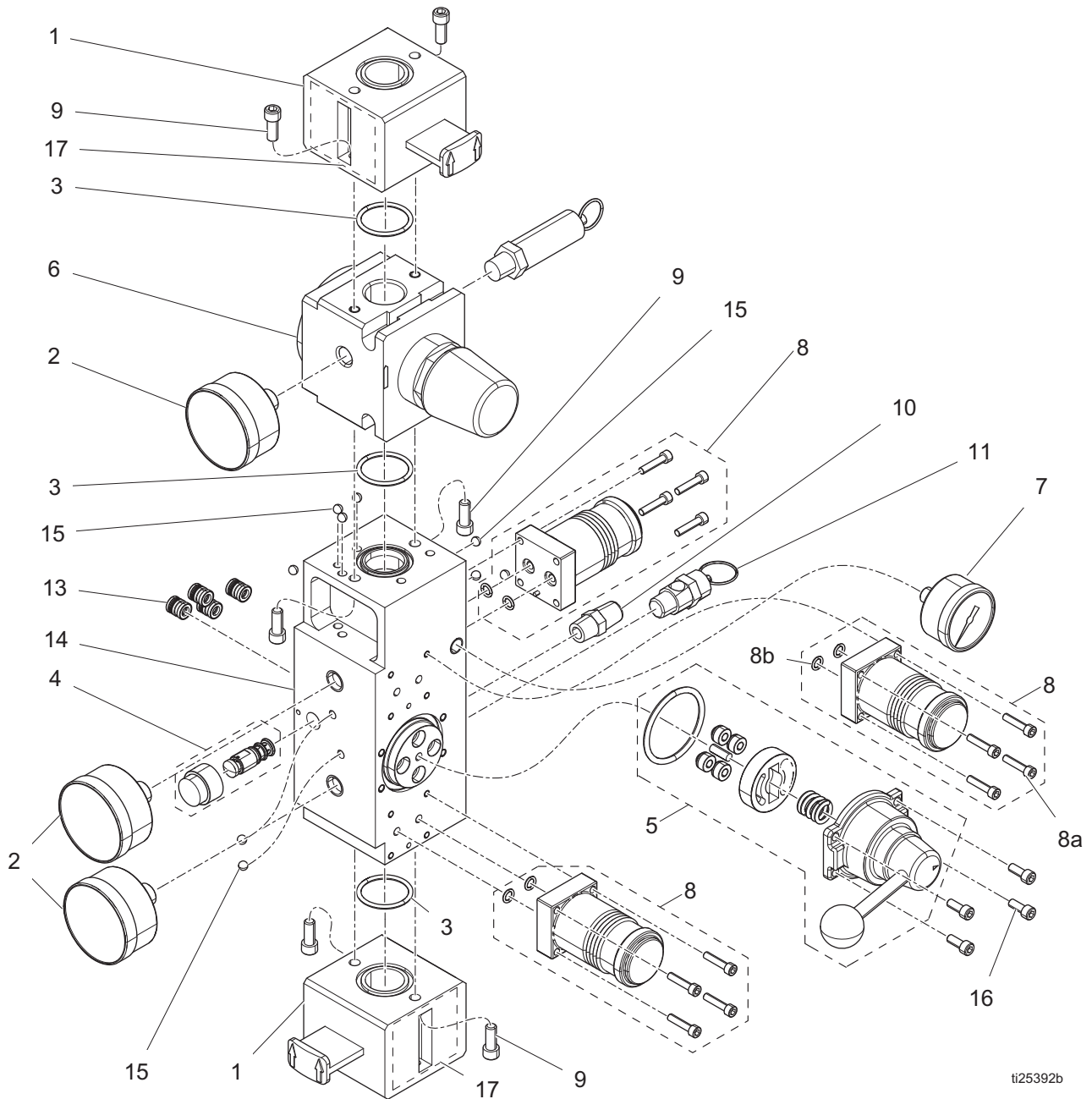

FIG. 4: Air Regulators Replacement

Parts

24W870 Air Control



ti25392b

FIG. 5: 24W870 Parts

Parts List - 24W870 Air Control

Ref.	Part	Description	Qty.
1	16Y167†	VALVE, shutoff, 3/4 npt	2
2	101689	GAUGE, pressure, air; 0-200 psi (0-1.4 MPa, 0-14 bar)	3
3	121110*†	O-RING, buna	3
4	121109	VALVE, blow-off (includes valve and push button)	1
5	121107	VALVE, control	1
6	255651	KIT, regulator, air motor	1
7	108190	GAUGE, pressure, air; 0-100 psi (0-700 kPa, 0-7 bar)	1
8	121106	REGULATOR, manifold mounting (includes 8a and 8b)	3
8a	---	SCREWS	4
8b	---	O-RING	2
9	121112*†	SCREW, cap, socket head	6
10	517449	MUFFLER, sintered, 1/4 npt	1
11	113498	VALVE, safety, 110 psi (0.8 MPa, 7.6 bar)	1
13	120602	FITTING, cartridge, 1/4	4
14	---	BLOCK, ram, control, 3 regulator	1
15	---	BALL, sst, 7/32 dia	11
16	120039	FASTENER, shcs, 10-32 x 1/2	4
17	15V954▲†	LABEL, valve, shutoff, air control	1

--- Not available for individual sale.

* Parts are available in kit 255651.

† Parts are available in kit 121108.

▲ Replacement safety labels, tags, and cards are available at no cost.

Graco Information

Sealant and Adhesive Dispensing Equipment

For the latest information about Graco products, visit www.graco.com.

For patent information, see www.graco.com/patents.

TO PLACE AN ORDER, contact your Graco distributor, go to www.graco.com, or call to identify the nearest distributor.

If calling from the USA: 1-800-746-1334

If calling from outside the USA: 0-1-330-966-3000

*All written and visual data contained in this document reflects the latest product information available at the time of publication.
Graco reserves the right to make changes at any time without notice.*

Original instructions. This manual contains English. MM 334201

Graco Headquarters: Minneapolis

International Offices: Belgium, China, Japan, Korea

GRACO INC. AND SUBSIDIARIES • P.O. BOX 1441 • MINNEAPOLIS MN 55440-1441 • USA
Copyright 2016, Graco Inc. All Graco manufacturing locations are registered to ISO 9001.

www.graco.com
Revision F, April 2020