

Lube Master[®] Floor Mount or Wall Mount Pump Package

3A2781E

EN

Provides a constant supply of lubrication to pump components. For professional use only.

Maximum Working Pressure: 5000 psi (340 bar, 34.0 MPa)

See page 3 for part number information.



Important Safety Instructions

Read all warnings and instructions in this manual before using the equipment. Save these instructions.

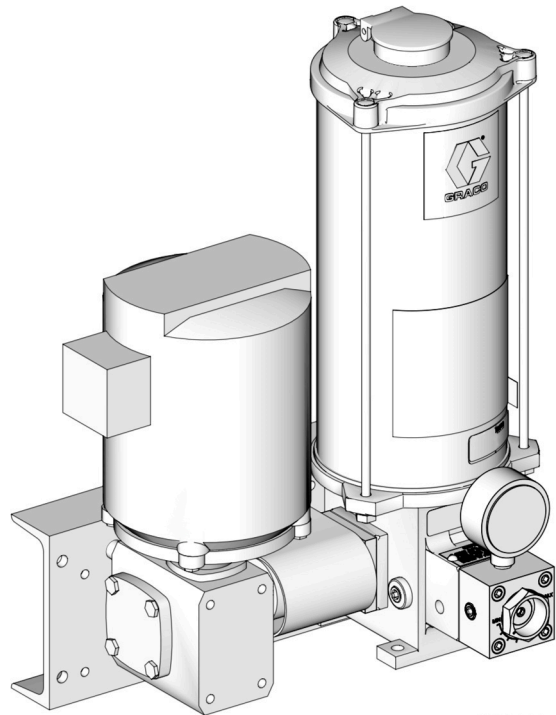

ti30111a

Table of Contents

Part Number	3	Parts	25
Warnings	4	Oil Reservoir Models:	
Component Identification	6	562892, 562893, 562894, 562895	25
(Pump Assembly)	6	Overhead Supply Adapter Assembly 562908 ..	26
Component Identification	7	Pump Assembly: 563380	27
Reservoir - Oil or Grease	7	Clutch Drive Assembly: 563383	28
Pump Assembly	7	Lube Master Pump Package	29
Installation	8	Lube Master Pump Package with Gear Reducer and Motor	
Grounding	8	(Up to 20 lbs): Wall Mounting	31
Pressure Relief Valve	8	Oil Reservoir Model with 15 Amp Low-Level Switch Assembly	32
Choose an Installation Location	8	Oil Reservoir Model with 10 Watt Low-Level Switch Assembly	32
Pump Package Installation Procedure	8	Grease Reservoir Model Low-Level Switch Assembly	33
Setup	9	Dimensions	34
Fill the Reservoir	9	Reservoirs	34
Fill the System	11	Reservoirs	35
Clutch Drive Adjustment (if equipped)	11	Clutch Drive	36
Standard Pump Adjustment	12	Clutch Drive	37
Operation	13	Lube Master (Up to 20lbs): Wall Mounting	38
Startup	13	Lube Master (Up to 20lbs): Floor Mounting ...	39
Pressure Relief Procedure	13	Lube Master (Up to 20lbs)	40
Troubleshooting	14	Technical Specifications	41
Maintenance and Repair	16	California Proposition 65	43
Pumps: Oil and Grease Models	16	Graco Standard Warranty	44
Grease Reservoir Models	17	Graco Information	44
Oil Reservoir Models	19		
Post Maintenance	23		
Clutch Drive Maintenance	23		
Recommended Lubricants for Enclosed Gear Reducers	23		
Alternative AGMA Lubricants	23		
Parts	24		
Grease Reservoir Models: 562896, 562897, 562898, 562899	24		

Part Number

Use the Part Number Key provided below to identify each component included in the Lube Master pump package Part Number. The Codes associated with each Option (A-D) that make up the Part Number are provided in the tables below. For example, Part Number - LM1321 is a Lube Master pump package with a 12 pint plastic oil reservoir. It has a 10:1 reduction ratio and is floor mounted. It is powered with a 115/230V, 1/2 hp, 1 PH, 60 Hz, 1725 RPM motor and does not have a low-level switch.

NOTE: Some part number configurations are not available. Contact Graco Customer Service or your local Graco distributor for assistance.

Part Key: **L M A - B - C - D**
 Part Example: **L M 1 3 2 1**

LM = Lube Master

Option A: Reservoir Options

Code	Reservoir Size: pints (liters)	Oil or Grease	Plastic or Metal
1	12 (5.68)	Oil	Plastic
2	20 (9.46)	Oil	Plastic
3	12 (5.68)	Oil	Metal
4	20 (9.46)	Oil	Metal

Code	Reservoir Size: pounds (kg)	Oil or Grease	Plastic or Metal
5	12 (5.44)	Grease	Plastic
6	20 (9.07)	Grease	Plastic
7	12 (5.44)	Grease	Metal
8	20 (9.46 L)	Grease	Metal
9	No Reservoir, Overhead Supply		

Option B: Drive Options

Code	Description	
	Reduction Ratio	Mounting Option
1	None	
2	Clutch Drive With Arm	
3	10:1	Floor Mounting
4	10:1	Wall Mounting
5	60:1	Floor Mounting
6	60:1	Wall Mounting

Option C: Motor Options





Code	Voltage	Horsepower	PH	Hz	RPM
1	None				
2	115/230	1/2	1	60	1725
3	230/460	1/2	3	60	1725
4	115/230	1/2	1	60	1140
5	230/460	1/2	3	60	1175

Option D: Low-Level Switch Options





Code	Size	Oil or Grease	SPDT	Amps	Watts
1	No low-level switch				
2	12 (5.68 L)	Oil	X	15	
3	20 (9.46 L)	Oil	X	15	
4	12 and 20 pounds (5.44 and 9.07 kg)	Grease			
5	12 (5.68 L)	Oil	X		10
6	20 (9.46 L)	Oil	X		10

Warnings

The following warnings are for the setup, use, grounding, maintenance, and repair of this equipment. The exclamation point symbol alerts you to a general warning and the hazard symbols refer to procedure-specific risks. When these symbols appear in the body of this manual or on warning labels, refer back to these Warnings. Product-specific hazard symbols and warnings not covered in this section may appear throughout the body of this manual where applicable.

 <h1 style="margin: 0;">WARNING</h1>	
	<p>ELECTRIC SHOCK HAZARD</p> <p>This equipment must be grounded. Improper grounding, setup, or usage of the system can cause electric shock.</p> <ul style="list-style-type: none"> • Turn off and disconnect power at main switch before disconnecting any cables and before servicing or installing equipment. • Connect only to grounded power source. • All electrical wiring must be done by a qualified electrician and comply with all local codes and regulations.
	<p>SKIN INJECTION HAZARD</p> <p>High-pressure fluid from dispensing device, hose leaks, or ruptured components will pierce skin. This may look like just a cut, but it is a serious injury that can result in amputation. Get immediate surgical treatment.</p> <ul style="list-style-type: none"> • Do not point dispensing device at anyone or at any part of the body. • Do not put your hand over the fluid outlet. • Do not stop or deflect leaks with your hand, body, glove, or rag. • Follow the Pressure Relief Procedure when you stop dispensing and before cleaning, checking, or servicing equipment. • Tighten all fluid connections before operating the equipment. • Check hoses and couplings daily. Replace worn or damaged parts immediately.
	<p>FIRE AND EXPLOSION HAZARD</p> <p>When flammable fluids are present in the work area, such as gasoline and windshield wiper fluid, be aware that flammable fumes can ignite or explode. To help prevent fire and explosion:</p> <ul style="list-style-type: none"> • Use equipment only in well ventilated area. • Eliminate all ignition sources, such as cigarettes and portable electric lamps. • Ground all equipment in the work area. • Keep work area free of debris, including rags and spilled or open containers of solvent and gasoline. • Do not plug or unplug power cords or turn lights on or off when flammable fumes are present. • Use only grounded hoses. • Stop operation immediately if static sparking occurs or you feel a shock. Do not use equipment until you identify and correct the problem. • Keep a working fire extinguisher in the work area.
	<p>BURN HAZARD</p> <p>Equipment and surfaces can become very hot during operation. To avoid severe burns:</p> <ul style="list-style-type: none"> • Do not touch hot equipment.

⚠️ WARNING

	<p>EQUIPMENT MISUSE HAZARD</p> <p>Misuse can cause death or serious injury.</p> <ul style="list-style-type: none"> • Do not operate the unit when fatigued or under the influence of drugs or alcohol. • Do not exceed the maximum working pressure or temperature rating of the lowest rated system component. See in all equipment manuals. • Use fluids and solvents that are compatible with equipment wetted parts. See in all equipment manuals. Read fluid and solvent manufacturer's warnings. For complete information about your material, request Safety Data Sheet (SDS) from distributor or retailer. • Turn off all equipment and follow the Pressure Relief Procedure when equipment is not in use. • Check equipment daily. Repair or replace worn or damaged parts immediately with genuine manufacturer's replacement parts only. • Do not alter or modify equipment. Alterations or modifications may void agency approvals and create safety hazards. • Make sure all equipment is rated and approved for the environment in which you are using it. • Use equipment only for its intended purpose. Call your distributor for information. • Route hoses and cables away from traffic areas, sharp edges, moving parts, and hot surfaces. • Do not kink or over bend hoses or use hoses to pull equipment. • Keep children and animals away from work area. • Comply with all applicable safety regulations.
 	<p>ENTANGLEMENT HAZARD</p> <p>Rotating parts can cause serious injury.</p> <ul style="list-style-type: none"> • Keep clear of moving parts. • Do not operate equipment with protective guards or covers removed. • Do not wear loose clothing, jewelry or long hair while operating equipment. • Equipment can start without warning. Before checking, moving, or servicing equipment, follow the Pressure Relief Procedure and disconnect all power sources.
	<p>PERSONAL PROTECTIVE EQUIPMENT</p> <p>Wear appropriate protective equipment when in the work area to help prevent serious injury, including eye injury, hearing loss, inhalation of toxic fumes, and burns. Protective equipment includes but is not limited to:</p> <ul style="list-style-type: none"> • Protective eyewear, and hearing protection. • Respirators, protective clothing, and gloves as recommended by the fluid and solvent manufacturer.

Component Identification

(Pump Assembly)

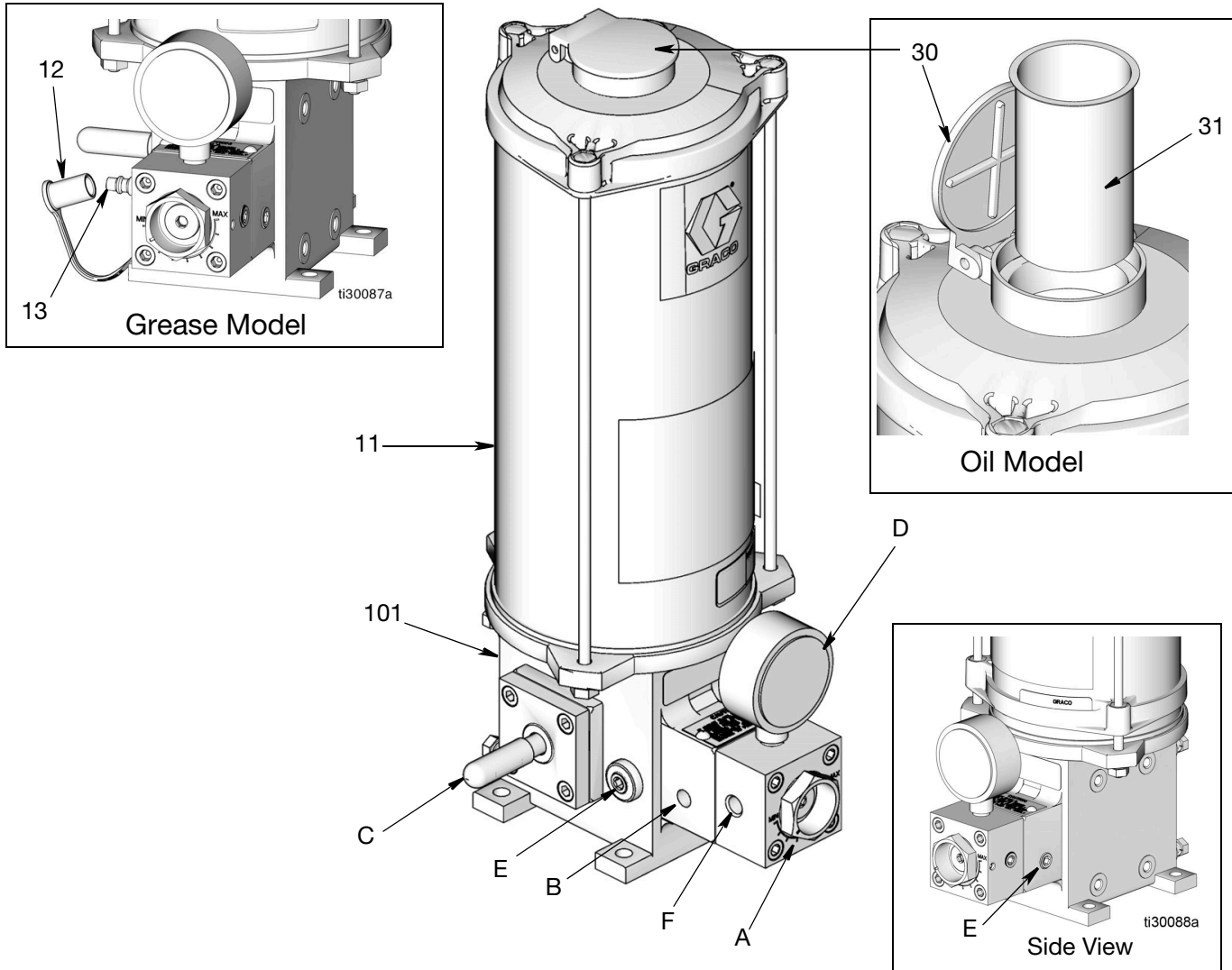

FIG. 1: Pump Assembly

- A Pump Adjustment Nut
- B Pump Inlet
- C Drive Shaft
- D Pressure Gauge
- E Drain and Drain Plug (Oil Models: one on each side of base); (Grease Models: one on the opposite side of the base from the fill stud (13))
- F Pump Outlet

- 11 Reservoir (Oil or Grease)
- 12 Fill Cap (Grease Only)
- 13 Fill Stud (Grease Only)
- 30 Fill Cap (Oil Only)
- 31 Filter Screen (Oil Only)
- 101 Pump Body

Component Identification

Every Lube Master pump package includes a pump assembly and a reservoir.

Reservoir - Oil or Grease

- Container for holding oil or grease.
- Grease models include a follower plate.
- The reservoir mounts directly to the Lube Master pump.

Oil Reservoir

- The oil reservoir has a fill cap (30) and screen (31), located on top (FIG. 2).

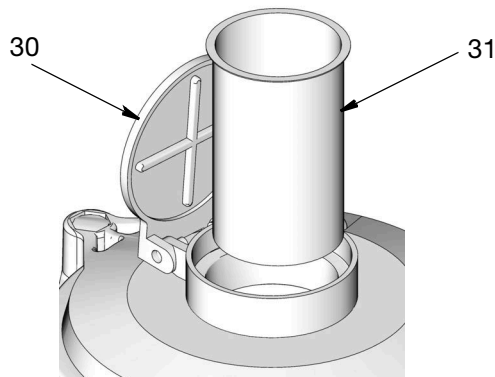

FIG. 2: Oil Reservoir

Grease Reservoir

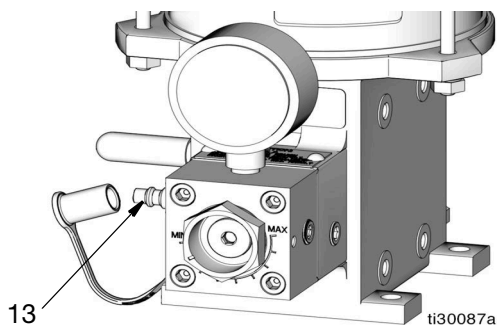

FIG. 3: Grease Reservoir

- The grease reservoir requires an external air-free supply source connected to the fill stud (13).

Pump Assembly

- The pump assembly can be driven by an electric motor or by a rotating or oscillating machine motion.
- The pump assembly must always be installed with the reservoir (11) in a vertical position to ensure proper operation.
- Always use lock washers with mounting bolts and make certain that the bolts are properly torqued.

Motor and Drive Options

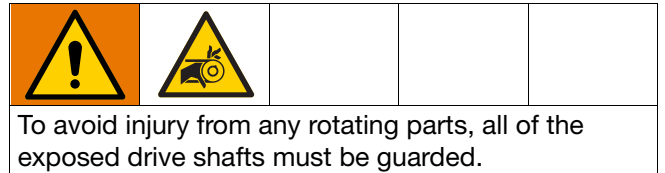

Gear Reducer

NOTICE

Gear reducer units are shipped without lubricant. Before operating, always check lubricant level and fill per manufacturers instructions. Operation without lubricant will damage the gear reducer. A table of suggested lubricants is provided on page 23.

Gear reducers have either a 10:1 or 60:1 reduction or an oscillating clutch drive that can be activated by a machine motion.

Low-Level Switch (Optional)





A Low-level switch provides a signal when the lubricant level in the reservoir is low.

Installation

The reference letters and numbers used in the following sections, refer to FIG. 1.

Components are completely assembled when the Lube Master pump package is received from the factory. Reassembly instructions for these components are provided in **Maintenance and Repair**, beginning on page 16.



Grounding

				
<p>The equipment must be grounded to reduce the risk of static sparking and electric shock. Electric or static sparking can cause fumes to ignite or explode. Improper grounding can cause electric shock. Grounding provides an escape wire for the electric current.</p>				

Install a 12 gauge (1.5 mm) minimum ground wire between the Lube Master pump package and a true earth ground.





Pressure Relief Valve

Pressure Relief Valve

				
<p>To prevent over-pressurization, which can result in serious injury from splashing fluids due to equipment rupture, a pressure relief valve must be installed close to every pump assembly outlet to alleviate unintended pressure rises in the system and protect the pump assembly from damage.</p>				

- The pressure relief valve must be rated for no more than the working pressure of any component installed in the system.
- Install a pressure relief valve close to every pump assembly outlet and before any auxiliary fitting.

Choose an Installation Location

				
<p>AUTOMATIC SYSTEM ACTIVATION HAZARD</p> <p>If the system is equipped with an automatic timer that activates the pump lubrication system, unexpected activation of the system could occur. This could result in serious injury, including skin injection and amputation from moving parts.</p> <p>Before installation or removal of the pump package from the system, disconnect power and relieve pressure.</p>				

- Select a location that will adequately support the weight of the pump package and lubricant, as well as all plumbing and electrical connections.
- Refer to the mounting hole layouts provided in **Dimensions**, beginning on page 34. No other installation configuration should be used.
- Use only the designated mounting holes and provided configurations.
- Use fasteners that are strong enough to support the weight of the pump package and lubricant when securing the pump package to the mounting surface.

Pump Package Installation Procedure

1. Secure the pump package with user supplied attaching hardware to the installation location. All fasteners should be tightened to the proper torque.
2. Install all guards and mechanical linkages or connections.
3. Connect the power source to the pump package drive.
4. Fill with lubricant. See **Fill the Reservoir**, beginning on page 9.

Setup

Fill the Reservoir

Material Cleanliness

The lubricant used to fill the system must be clean. If there is doubt about cleanliness, the lubricant should be filtered before using in the system. System life and consistent operation will both be improved by using clean lubricant.

After filtering the lubricant, protect the lubricant supply from debris.

On all pump packages, the lube piston diameter is very close to the diameter of the chamber in the pump body. Contaminants in the lubricant could cause scoring, resulting in erratic pump operation and costly parts replacement.

Temperature Effects

Flow characteristics of the lubricant may change due to drastic temperature changes. Choose a lubricant that flows properly at all temperatures expected in the system environment.

Overhead Supply Adapter Assemblies Only

The recommended inlet pressure is 15 psi (0.103 MPa, 1.03 bar) or less.

Fill Oil Reservoir Model

The reservoir on oil models has a fill cap (30) and filter screen (31).

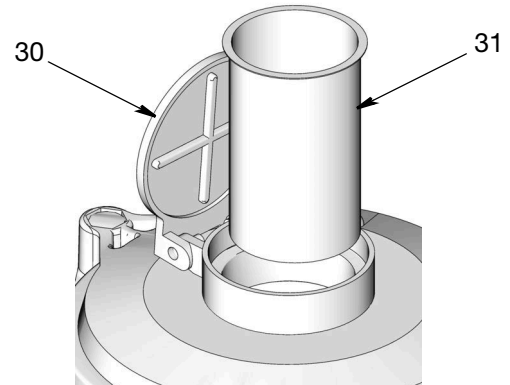

FIG. 4: Oil Reservoir

1. Clean the area around the fill cup to avoid contamination during filling.
 2. Open the fill cap (30) and slowly pour oil into the reservoir (11) through the filter screen (31).
- NOTE:** The filter screen (31) removes any large particles present in the oil.
3. When filling is complete, close the fill cap (30) and clean up any spillage.

Fill Grease Reservoir Model

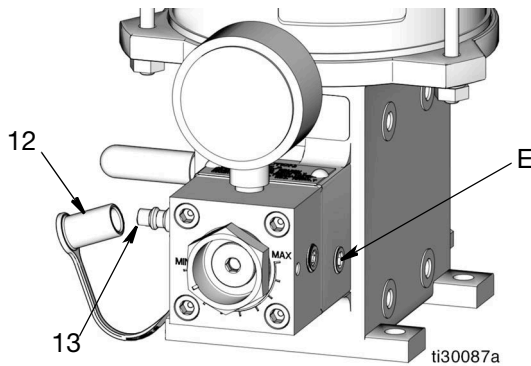

Fig. 5: Fill Grease Reservoirs

- Filling the grease reservoir requires an external, air-free supply source connected to the fill stud (13).
- Avoid introducing air into the system, by keeping enough grease in the supply source to fill the reservoir without being disconnected.
- Operate the supply source at a steady speed to allow air-free filling of the reservoir. Filling the reservoir too fast may result in air pockets.
- Visually check the level of grease.
 - For reservoirs with plastic cylinders, the grease level can be viewed through the cylinder.

1. Remove the fill cap (12)
2. Connect the grease supply source to the fill stud (13).
3. Loosen the drain plug (E), located on the opposite side of the base from the fill stud (13) (FIG. 6).

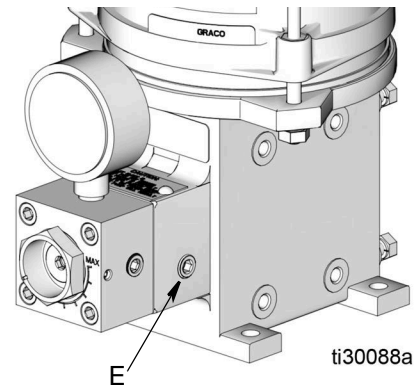

Fig. 6: Drain Plug

4. Begin to slowly fill the reservoir, allowing for air trapped under the follower to exhaust out the open drain plug.
5. After grease that is free of air flows from the drain, tighten the plug (E) and continue to fill the reservoir until follower is at the vent hole in reservoir tube (any remaining air and small amount of grease will exit drain).
6. When filling is complete, turn off the supply source and disconnect it from the fill stud (13). Replace the cover (12).

NOTE: Integrating a check valve inside of the fill stud prevents lubricant from being forced back out.

7. Loosen the pump assembly outlet fitting.
8. Operate the pump until lubricant that is free of air flows from the outlet port.
9. Tighten the mainline connection at the pump. The pump is now free of air.

NOTE: If the pump will not take a prime, inject several ounces of heavy oil through the fill stud. The pump primes on the oil pulling the grease behind it. If this method is used, all injected oil should be discharged at the loosened system mainline connection, in addition to any air.

Fill the System

Fill the pump package reservoir, as described in **Fill the Reservoir**, page 9. After it is filled, the remainder of the system is filled by attaching a hand pump to the system downstream from the pump manifold block assembly, then cycle the hand pump until the system is filled.

Clutch Drive Adjustment (if equipped)

The clutch lever throw is adjustable between 12 and 60 degrees. Table 1 (page 12) provides the minimum/maximum pump outputs. The actual pump output of the installation is computed using the Calculating Pump Output procedure found on page 12.

Use the clutch lever diagram (FIG. 7) to determine the anticipated clutch lever throw angle.

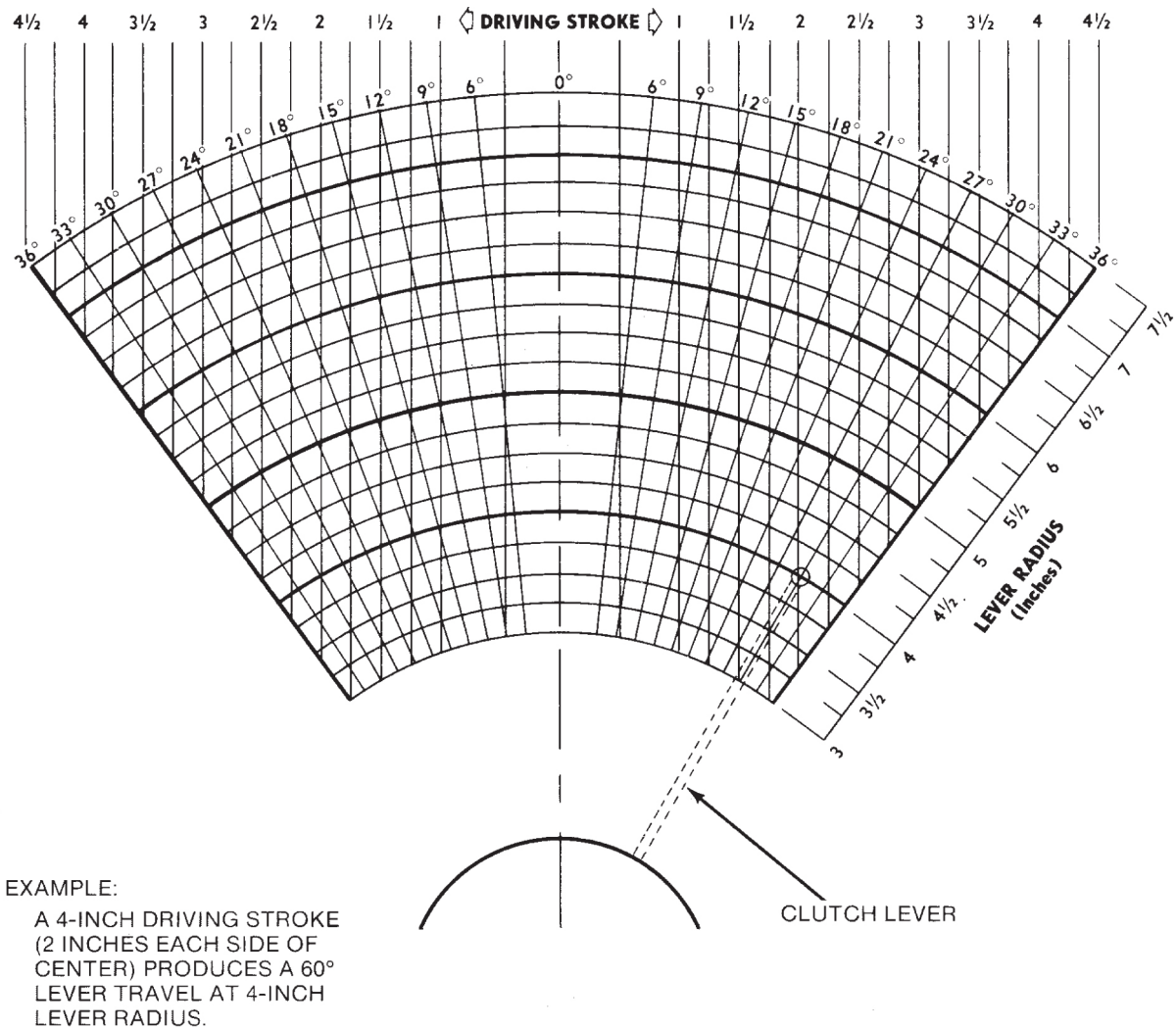

Fig. 7: Clutch Lever Diagram

Clutch Drive - Calculating Pump Output (if equipped)

The standard pump output varies from 0.010 to 0.050 cubic in. (0.1639 to 0.8195 cu. cm) per cycle, by changing the position of the pump adjustment nut (A) (FIG. 1, page 6), located below the pressure gauge (D) (FIG. 1, page 6).

Use the following formulas to calculate the pump output per hour:

$$\frac{360^\circ}{\text{Degrees of Throw}} = \text{Effective Ratio}$$

* Degrees of Throw can be found by using clutch lever diagram (FIG. 7, page 11)

$$\frac{\text{IMPULSES/HOUR}}{\text{RATIO}} = \text{PUMP STROKE PER HOUR}$$

Pump strokes per hour x 0.010 = Minimum Pump Output per Hour

Pump strokes per hour x 0.050 = Maximum Pump Output per Hour

Table 1: Minimum / Maximum Pump Output

Degrees of Throw	Effective Ratio	Impulses Per Minute	Output Per Hour Pump Strokes Per Hour	Cubic Inches (Cubic Centimeters)/hour	
				Minimum	Maximum
12	30:1	5 Minimum	10	0.100 (1.639)	0.500 (8.195)
60	6:1	150 Maximum	1500	15.00 (245.8)	75.00 (1229)

Standard Pump Adjustment

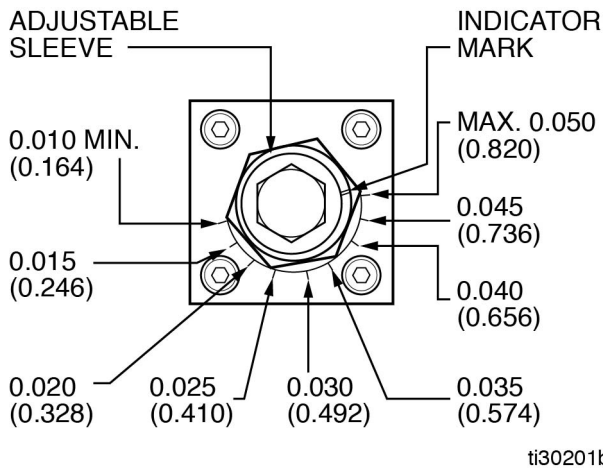

FIG. 8: Standard Pump Adjustment

Table 2: Standard Output/Stroke Adjustment

Percent of Output	Output Per Stroke Cubic Inches (Cubic Centimeters)	Adjustment Mark
100	0.050 (0.820)	Max.
90	0.045 (0.736)	*1st
80	0.040 (0.656)	*2nd
70	0.035 (0.574)	*3rd
60	0.030 (0.492)	*4th
50	0.025 (0.410)	*5th
40	0.020 (0.328)	*6th
30	0.015 (0.246)	*7th
20	0.010 (0.164)	Min.

* All marks are counting clockwise from the maximum setting.

Operation



Startup

Before operating any component in the system, check the following:

- The reservoir is securely fastened in the pump assembly and that the fill cap or grease-fill fitting is easily reached.
- The pump package is securely fastened in place.
- The gear reducer is filled with the proper lubricant, see page 23.
- The electrical connections to any controllers, level switches or pressure switches used on the system are tight.
- All of the accessories plumbed into the output manifold block assembly are secure.
- All of the hose or tube connections are tight.
- The reservoir is filled with lubricant. See **Fill the Reservoir**, page 9.
- All filling and bleeding steps have been completed.
- The output of the pump assembly. To adjust the output, see page 12.
- For models equipped with a clutch drive, verify it is properly adjusted, see **Clutch Drive Adjustment (if equipped)**, page 11.

The pump package is ready for operation.

While the system is operating, periodically check the following components:

- The pump is cycling according to schedule.
- Visually check the unit for leaks and loose fittings. Make sure that the hoses are not kinked or rubbing on anything.
- If the reservoir is not equipped with a low-level switch, visually check the lubricant level and refill before all lubricant is used.

NOTE: If the reservoir is allowed to run out of lubricant, excess air will be introduced into the system, requiring that the system be bled.

Pressure Relief Procedure



Follow the Pressure Relief Procedure whenever you see this symbol.

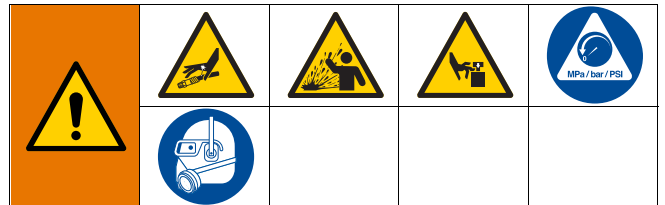

This equipment stays pressurized until pressure is manually relieved. To help prevent serious injury from pressurized fluid, such as skin injection, splashing fluid and moving parts, follow the Pressure Relief Procedure when you stop dispensing and before cleaning, checking, or servicing the equipment.

1. Verify pump is stopped and disconnected from the power source.
2. Using a wrench, slowly loosen the outlet fitting (a, FIG. 9) connected to the pump assembly until the fitting is loose and no more lubricant or air is leaking from the fitting.

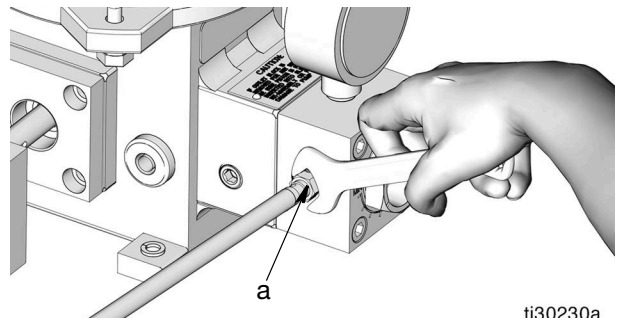
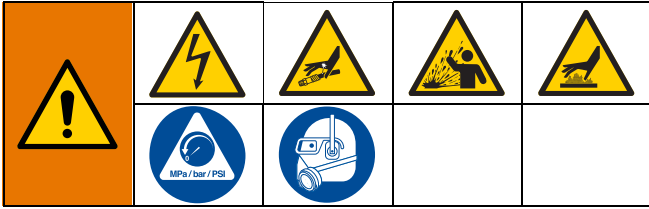

FIG. 9: Pressure Relief

ti30230a

Troubleshooting









1. Follow **Pressure Relief Procedure**, page 13, before checking or repairing the pump.
2. Check all possible problems and causes before disassembling the pump, including loose connections or air trapped in the system.

Problem	Cause	Solution
No lubrication is dispensed from pump, but pump is rotating	Reservoir is empty	Refill as required. See Filling The Reservoir, page 9.
	Check valve is defective	Clean and install seal repair kit.
	Adjustment sleeve seals are defective	
	Problem is in the pump	See Pump is Not Running or Requires Servicing section of this Troubleshooting Table.
Pump is Not Running or Requires Service	Yoke connector pin and piston are defective	Replace defective parts using Pump Drive Repair Kit.
	Sheared drive motor key	Replace key.
	Broken pump drive shaft	Replace defective parts using Pump Drive Repair Kit.
	Piston is not engaged in sleeve	Replace defective parts using Output Manifold Kit.
No lubrication is dispensed from pump and drive shaft is not rotating	Motor is not running	Refer to Motor is Not Running section of this Troubleshooting Table.
	No gear reducer output	Refer to No Gear Reducer Output section of this Troubleshooting Table.
	Defective pump input shaft	Replace defective parts using Pump Drive Repair Kit.
Motor is Not Running	Power is off	Turn power on.
	Electric connections to motor or timer are loose	Check all connections and tighten securely.
	Timer/controller is set incorrectly or defective	Set timer/controller to correct setting. If unit is still not functioning, repair or replace timer/controller.
No Gear Reducer Output	Key is sheared or missing at coupling	Replace key.
	Defective gearbox	Gearbox must be replaced. For this repair unit must be returned to an authorized Graco repair facility.

Problem	Cause	Solution
Clutch drive is operating but there is no flow	Reservoir is empty	Refill as required. See Filling The Reservoir, page 9.
	Clutch is defective	Remove clutch and operate pump manually. <ul style="list-style-type: none"> • If there is output, replace clutch. For this repair unit must be returned to an authorized Graco repair facility. • If there is no output, see Pump is Not Running or Requires Servicing section of this Troubleshooting Table.
	Fluid temperature is below 12°F (-11°C)	Do not attempt to operate until temperature problem is corrected.
Erratic pump output	System was not bled properly	Bleed manifold. See Manifold Bleeding, page 11.
	Pump seals, check valves or o-rings are defective	Replace defective parts using Pump Drive Repair Kit.
	Pump adjustment assembly is leaking or sucking air during return stroke	Tighten output manifold block assembly components.
	Piston or bore is worn	Replace defective parts using Output Manifold Kit.
Grease Models		
Lubricant is leaking from the reservoir	Hex nuts (1) are not tight	Tighten hex nuts (1). Torque to 5 ft. lbs (6.78 N•m).
	Damaged or worn gasket (8)	Replace gasket (8).
	Cracks or nicks in reservoir tube (11) or reservoir is dented or out-of-round	Replace reservoir tube (11).
Restricted movement of follower plate	Dented or out-of-round reservoir tube (11)	Replace reservoir tube (11).
Pump will not take a prime	Grease will not pull into pump through quick disconnect	Inject several ounces of heavy oil through the grease fill quick disconnect. The pump will then prime on oil, pulling the grease behind it. If it becomes necessary to use this method, all injected oil should be discharged at the loosened system supply connection along with any air.
Oil Models		
Oil reservoir is filling very slowly	Fill screen (31) located in fill cap (30) is clogged	Clean or replace fill screen (31).
Lubricant is leaking from the reservoir	Hex nuts (1) are not tight	Tighten hex nuts (1). Torque to 5 ft. lbs (6.78 N•m)
	Damaged or worn gasket (8)	Replace gasket (8)
	Cracks or nicks in reservoir tube (11) or reservoir is dented or out-of-round	Replace reservoir tube (11)
	Overhead supply adapter only: Exceeded recommended inlet pressure of 15 psi (0.103 MPa, 1.03 bar)	Decrease pressure to 15 psi (0.103 MPa, 1.03 bar) or less

Maintenance and Repair

Pumps: Oil and Grease Models

AUTOMATIC SYSTEM ACTIVATION HAZARD

If the system is equipped with an automatic timer that activates the pump package, unexpected activation of the pump package could occur. This could result in serious injury, including skin injection and amputation from moving parts.

Before installation or removal of the pump assembly from the system, disconnect power and relieve pressure.

Before proceeding with any maintenance, the following procedure must be completed:

1. Disconnect all power to the pump.
2. Follow the **Pressure Relief Procedure**, page 13.
3. Remove pipe plug (116, FIG. 10) and drain oil or grease into a suitable, clean container.
4. Install plug (116) after draining is complete.
5. Remove the reservoir.
6. Remove pump body assembly from the mounting:
 - a. Remove all guards and mechanical linkages or connections at the pump drive shaft (104).
 - b. Remove all attaching hardware securing pump body (101) in place.
 - c. Remove all grease or oil from the pump body (101).

Prepare for Maintenance

Refer to FIG. 10 for reference numbers used in the following instructions.

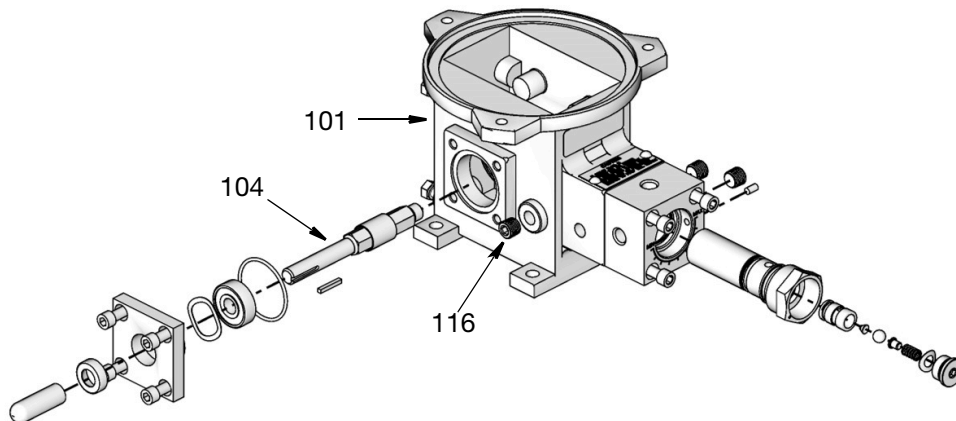

FIG. 10:

Grease Reservoir Models



Refer to FIG. 11 for reference numbers used in the following instructions.

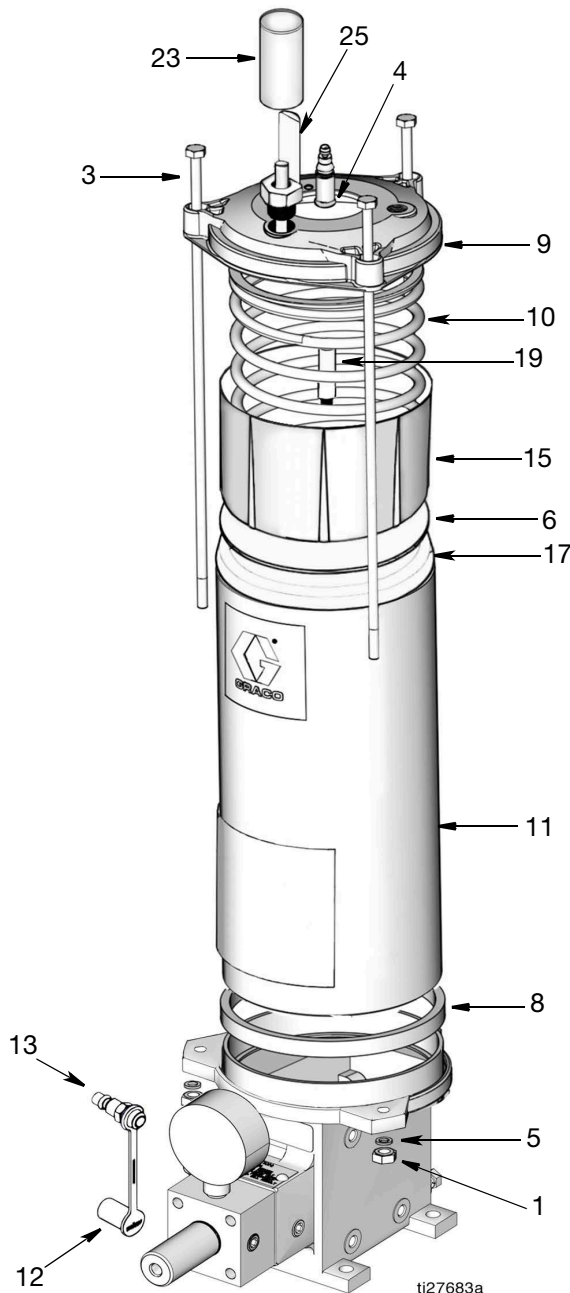

FIG. 11:

Disassembly

The disassembly procedure may be performed with the reservoir mounted on the pump assembly. However, some mounting locations are too restrictive to provide access to all components.

If installation requires dismantling of the reservoir, drain the reservoir of lubricant before removing the attaching hardware. This reduces the weight of the reservoir and reduces the chance of spillage.

FLYING PARTS HAZARD				
The expansion spring (10) is always under great tension and could be propelled with enough force to cause serious injury. Never remove retaining ring (4) or cable assembly (19).				

1. Follow **Prepare for Maintenance**, page 16.
2. Slowly open the reservoir drain (E), FIG. 1, page 6, and allow the lubricant to flow into a container.

Drain all lubricant before removing the attaching hardware to reduce the weight of the reservoir and to reduce the chance of spillage.

3. Properly dispose of emptied grease adhering to all applicable safety regulations and municipality codes.
4. Remove the fill stud (13), if necessary (FIG. 11).
5. Remove hex nuts (1) and lock washers (5) from the tie rods (3) (FIG. 11).
6. Remove tie rods (3) from reservoir cap (9) (FIG. 11).
7. Lift the reservoir (11) from the pump, keeping the reservoir cap (9) in position on top of the tube (FIG. 11).
8. Slide the reservoir (11) away from the reservoir cap (9) until it is free from the follower cups (15 and 17) (FIG. 11).
9. Remove the gasket (8) from the pump (FIG. 11).

NOTE: Further disassembly is only possible at the factory. If damage is apparent on the follower cups (15 and 17), cable assembly (19), spring (10) or reservoir cap (9) the unit cannot be serviced and the reservoir assembly must be replaced.

Reassembly

Lubricate the follower cups (15 and 17) (FIG. 11) and the inner diameter of the reservoir tube (11) before reassembling the pump assembly with the same lubricant used in the system.

1. Slide the reservoir (11) over the follower cups (15 and 17) upwards until it contacts the reservoir cap (9), being careful not to distort the follower cup lips.
2. Install a new gasket (8) on the pump.
3. Place the reservoir (11) on the gasket (8) and rotate the reservoir cap (9) until the holes in the cap line up with the holes in the pump.
4. Install the tie rods (3) through the holes in the reservoir cap (9) and pump.
5. Install lock washers (5) and hex nuts (1) onto the tie rods (3) and torque to 5 ft-lbs (6.78 N•m).
6. Install the fill stud (13) and dust cap (12) in the pump.

NOTE: After reassembly, any components removed to ease disassembly should be reinstalled on the reservoir.

Low-Level Switch Assembly

Refer to FIG. 12 for reference numbers used in the following instructions.

If the grease level is too low and the switch assembly fails to perform as required:

- check that the electrical connections are secure.
- check for any physical obstructions that prevent the switch from operating. If an obstruction is found, disassemble the unit and clear the obstruction.

If the switch assembly is damaged, replace it using the following procedure:

Remove



1. Follow **Prepare for Maintenance**, page 16.
2. Disconnect the wiring from the low-level switch terminals (304) (FIG. 13).
3. Remove the nuts attaching the low-level switch (304) to the bracket (A) (FIG. 12).

4. Remove the low-level switch (304) from the bracket (A).
5. Remove the retainer ring (B) and spring (C).
6. Remove the three screws (D) and the bracket (A).

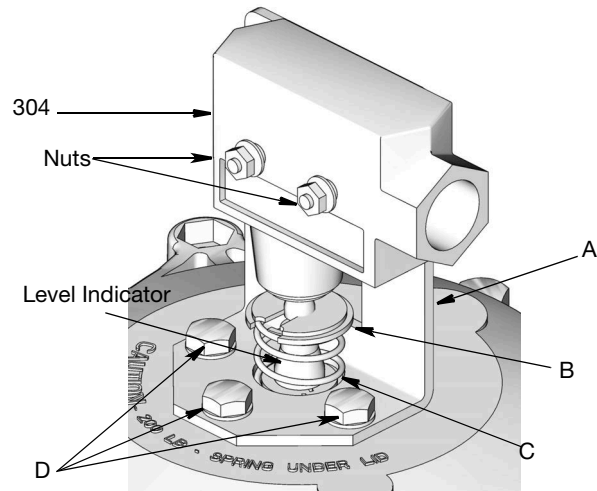

FIG. 12:

Install

1. Attach the bracket (A) to the grease reservoir cover using the three screws (D) (FIG. 12).
2. Place the spring (C) (FIG. 12) over the tip of the level indicator.
3. Compress the spring (C) and place the retainer ring (B) between the spring and the tip of level indicator (FIG. 12).
4. Attach the low-level switch (304) to the bracket (A) with the nuts (FIG. 12).
5. Wire the low-level switch (304) in accordance with local electrical codes. Refer to wiring diagram, FIG. 13.

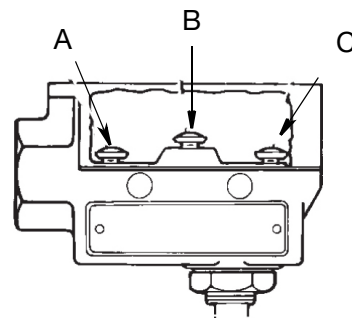

FIG. 13: Low-Level Switch Wiring

- A Normally closed
- B Normally open
- C Common

Oil Reservoir Models



Refer to FIG. 14 for reference numbers used in the following instructions.

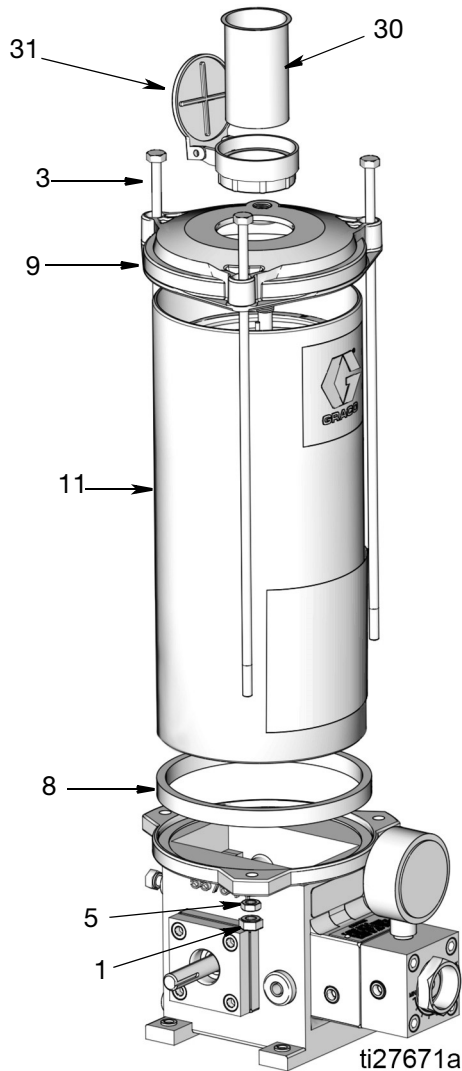

FIG. 14

Disassembly

The disassembly procedure may be performed with the reservoir mounted on the pump assembly. However, some mounting locations may be too restrictive to provide access to all components.

If installation requires dismantling of the reservoir, drain the reservoir of lubricant before removing the attaching hardware. This reduces the weight of the reservoir and reduces the chance of spillage.

1. Follow **Prepare for Maintenance**, see page 16.
2. Drain the oil into a container and properly dispose of emptied oil.
3. Remove the three hex nuts (1) and lock washers (5) from the tie rods (3).
4. Remove the tie rods (3) from the reservoir cover (9).
5. Remove the reservoir cover (9) from the reservoir (11).
6. Remove the fill screen (30) from the fill cap (31) and clean the screen.
7. Remove the reservoir (11) from the pump.
8. Remove and discard the gasket (8) from the pump.

Reassembly

1. Install the fill screen (30) in the fill cap (31).
2. Install a new gasket (8) in the pump.
3. Position the reservoir (11) on the pump and position the reservoir cover (9) on the tube.
4. Align the holes in the reservoir cover (9) and the holes in pump.
5. Install the tie rods (3) through the holes in the cover and the pump. The heads of the tie rods (3) must fit into the hexagonal depressions on the upper surface of the reservoir cover (9).
6. Install the lock washers (5) and hex nuts (1) on the tie rods (3).
7. Torque the hex nuts to 5 ft-lbs (6.78 N.m).

NOTE: After reassembly, any components removed to ease disassembly should be reinstalled on the reservoir.

15 Amp Low-Level Switch Assembly Option



Refer to FIG. 15 for reference numbers used in the following instructions.

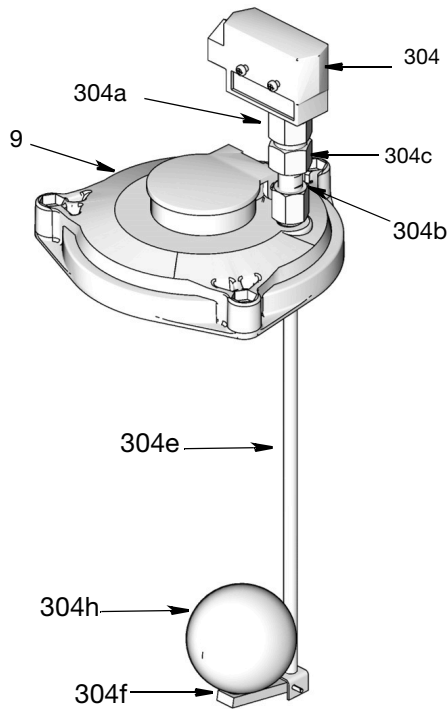

FIG. 15

If the oil level is too low and the assembly fails to perform as required, the pump assembly may have to be disassembled to replace a defective switch assembly.

Before disassembling, check that all electrical connections are secure and check for any physical obstruction preventing the float (304h) from operating.

Disassembly

1. Follow **Prepare for Maintenance**, page 16.
2. Remove the cover (9) from the reservoir (11).
3. Unscrew the union nut (304c) from the switch adapter (304a).
4. Unscrew the switch adapter (304a) from the switch (304).
5. Remove the actuating rod (304e), part of low-level lower assembly (304f), from the remaining assembly.

6. Unscrew the low-level lower assembly (304f) from the low-level adapter (304b).
7. Unscrew the low-level adapter (304b) from the reservoir cover (9).
8. Remove the low-level adapter (304b) from the union nut (304c).

Reassembly

The following procedure is used for installing a new assembly in a reservoir. If the assembly was removed for repairs, Steps 1 and 2 do not apply.

1. Remove the cover (9) from the reservoir (11).
2. Remove 1/4 in. plug (7) from the reservoir cover (9).
3. Insert the low-level adapter (304b) into the union nut (304c).
4. Insert the low-level adapter (304b) into the reservoir cover (9) and tighten securely.
5. Place the low-level lower assembly (304e) into the low-level adapter (304b) and tighten securely.

If the float (304h) from the low-level lower assembly was removed during disassembly, apply medium strength thread lock to the attaching bolt and securely attach the float (304h) to the arm (304f).

6. Insert the actuating rod (304e), part of low-level lower assembly (304f), into this assembly.
7. Place the switch adapter (304a) into the switch (304) and tighten securely.
8. Insert the union nut (304c) onto switch adapter (304a) and tighten securely.
9. Install the cover (9) on the reservoir (11).
10. Wire the switch (304) in accordance with local electrical codes. Refer to wiring diagram (FIG. 16).

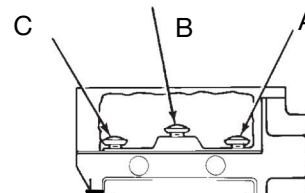

FIG. 16: Wire Switch

- A Normally closed
- B Normally open
- C Common

10 Watt Low-Level Switch Assembly Option



Refer to FIG. 17 for reference numbers used in the following instructions.

No maintenance is required on the 10 watt low-level assemblies used on oil reservoirs.

If the oil level is too low and the assembly fails to perform as required, the pump assembly may have to be disassembled to replace a defective switch assembly.

Before disassembling, check that all electrical connections are secure and check for any physical obstruction preventing the float (304h) from operating.

Disassembly

1. Follow **Prepare for Maintenance**, page 16.
2. Disconnect the two 22 AWG wires from the top of the adapter (304k).
3. Disconnect the adapter (304k) from the conduit.
4. Remove the cover (9) from the reservoir (11).
5. Unscrew the coupler (304m) from the adapter (304k). Use caution to not twist the wires too much.
6. Unscrew the coupler (304m) from the coupling (304n).
7. Unscrew the coupling (304n) from the switch (304p).
8. Unscrew the adapter (304k) from the reservoir cover (9).

Reassembly

The following procedure is used for installing a new assembly in a reservoir. If the assembly was removed for repairs, steps 1 and 2 do not apply.

1. Remove the cover (9) from the reservoir (11).
2. Remove the 1/4 in. pipe plug from the cover. Screw the adapter (304k) into place and tighten securely.
3. Guide the two 22 AWG wires from the switch (304p) through the coupling (304n).
4. Place the coupling (304n) onto the switch (304p) and tighten securely.
5. Guide the two 22 AWG wires through the coupler (304m).
6. Place the coupler (304m) into the coupling (304n) and tighten securely.
7. Guide the two 22 AWG wires through the adapter (304k).
8. Insert the coupler (304m) into the adapter (304k). Use caution to not to twist the wires too much.
9. Tighten the connection.
10. Connect the switch (304p) in accordance with local electrical codes.

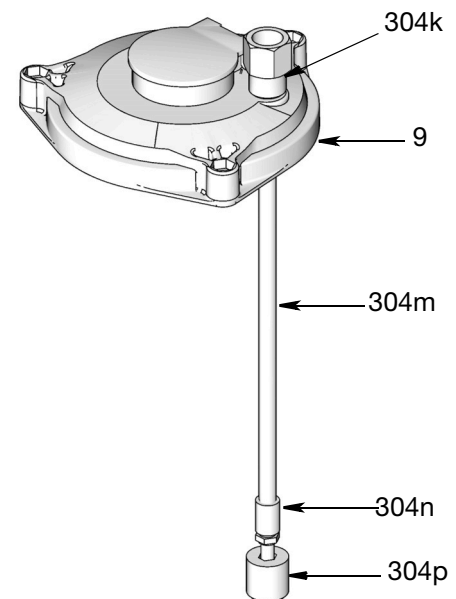

FIG. 17:

Overhead Supply Adapter (Oil Reservoir Models)



Refer to FIG. 18 for reference numbers used in the following instructions.

The Overhead Supply Adapter replaces the standard oil reservoir and allows the oil to be directly fed to the pump through a hole in the reservoir cap.

Disassembly

The disassembly procedure may be performed with the adapter mounted on the pump. However, some mounting locations may be too restrictive to provide access to all components.

If installation requires dismounting of the adapter, drain the adapter of lubricant before removing the attaching hardware. This reduces the weight of the adapter and reduces the chance of spillage.

1. Shut off the lubricant supply to the overhead supply adapter and drain the oil from the reservoir. Follow **Prepare for Maintenance**, on page 16, for reservoir draining instructions. Properly dispose of emptied oil adhering to all applicable safety regulations and municipality codes.
2. Remove the three nuts (201) and lock washers (204) from screws (203).
3. Remove the screws from the reservoir cap (209).
4. Remove the reservoir cover (209) from the adapter tube (210).
5. Remove the adapter tube (210) from pump.
6. Remove and discard the gaskets (205 and 206).

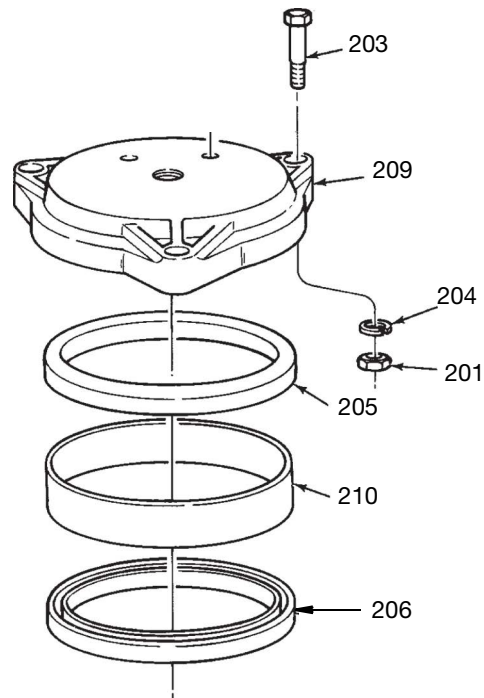

FIG. 18:

Reassembly

1. Install the lower gasket (206) on the pump body.
2. Install the adapter tube (210) on the gasket (206).
3. Install the reservoir gasket (205) on top of the adapter tube (210).
4. Install the reservoir cap (209) on the reservoir gasket (205).
5. Rotate the reservoir cover (209) until the screws (203) can be installed through the holes in the cap and the pump. The heads of the screws (203) must fit into the hexagonal depressions on the upper surface of the reservoir cover (209).
6. Install the lock washers (204) and nuts (201) on the screws (203).
7. Torque the nuts to 5 ft-lbs (6.78 N•m).

NOTE: After reassembly, any components removed to ease disassembly should be reinstalled on the adapter.

Pump Drive Repair Kit 563915

See instructions included with repair kit for procedure.

Output Manifold Repair Kit 563916

See instructions included with repair kit for procedure.

Seal Repair Kit 563921

See instructions included with repair kit for procedure.

Post Maintenance

After pump maintenance is completed, perform the following to return the unit to service:

1. Place the pump body and assembled parts from where it was removed and secure with attaching hardware. Tighten all fasteners to the proper torque.
2. Install all guards and mechanical linkages or connections that were removed from the pump drive shaft.
3. Connect the power source to the pump package.
4. Replace the drain plug (116).

Clutch Drive Maintenance

There is little maintenance required on the clutch drive.

The clutch drive assembly replacement part number 563383 is available from Graco. Contact your local Graco distributor for assistance in ordering this part.

Recommended Lubricants for Enclosed Gear Reducers

AMBIENT (Room) TEMP	RECOMMENDED OIL (or equivalent)	VISCOSITY RANGE SUS @ 100° F (38°C)	LUBRICANT AGMA NO.	ISO VISCOSITY GRADE NO. +
-30° to 225° F** (-34° to 107°C)	MOBIL SHC 634* SYNTHETIC	1950/2150	---	320/460
40° to 90° F (4.4° to 32.2°C)	MOBIL 600W CYLINDER OIL	1920/3200	7 or 7C	460
80° to 125° F (26.7° to 51.7°C)	MOBIL EXTRA HECLA SUPER CYLINDER OIL	2850/3600	8 or 8C	680

The gear reducer requires 7.8 oz (230.7 ml) of clean lubricant as listed above.

The lubricant must remain free from oxidation and contamination by water or debris, since only a very thin film of oil stands between efficient operation and failure. To assure long service life, the reducer should be periodically drained (preferably while warm) and refilled to the proper level with a recommended gear oil. Under normal environmental conditions oil changes are suggested after the initial 250 hours of operation and thereafter at regular intervals of 2500 hours or every 6 months.

Synthetic lubricants allow extended lubrication intervals because of increased resistance to thermal and oxidation degradation. It is suggested that the initial oil change be made at 1,500 hours, with additional oil changes scheduled at 5,000 hour intervals.

Alternative AGMA Lubricants

MANUFACTURER	LUBRICANT NAME	AGMA RATING
Getty Refining Co.	Veedol Asreslube 98	8 EP
Getty Refining Co.	Veedol Asreslube 95	7 EP
Getty Refining Co.	Veedol Asreslube 90	6 EP
Lubrication Engr. Inc.	Almasol 609	8
Lubrication Engr. Inc.	Almasol 608	7
Mobil Oil Corp.	Mobilgear 634	8 EP
Mobil Oil Corp.	Mobil Extra Hecia Super	8
Mobil Oil Corp.	Mobil Cylinder 600W	7
Shell Oil Co.	Omala 460	7 EP
Shell Oil Co.	Valvala J460	7
Shell Oil Co.	Omala 680	8 EP
	Valvala J680	8
Texaco Inc.	Meropa 680	8 EP
Texaco Inc.	Meropa 460	7 EP

Parts

Grease Reservoir Models: 562896, 562897, 562898, 562899

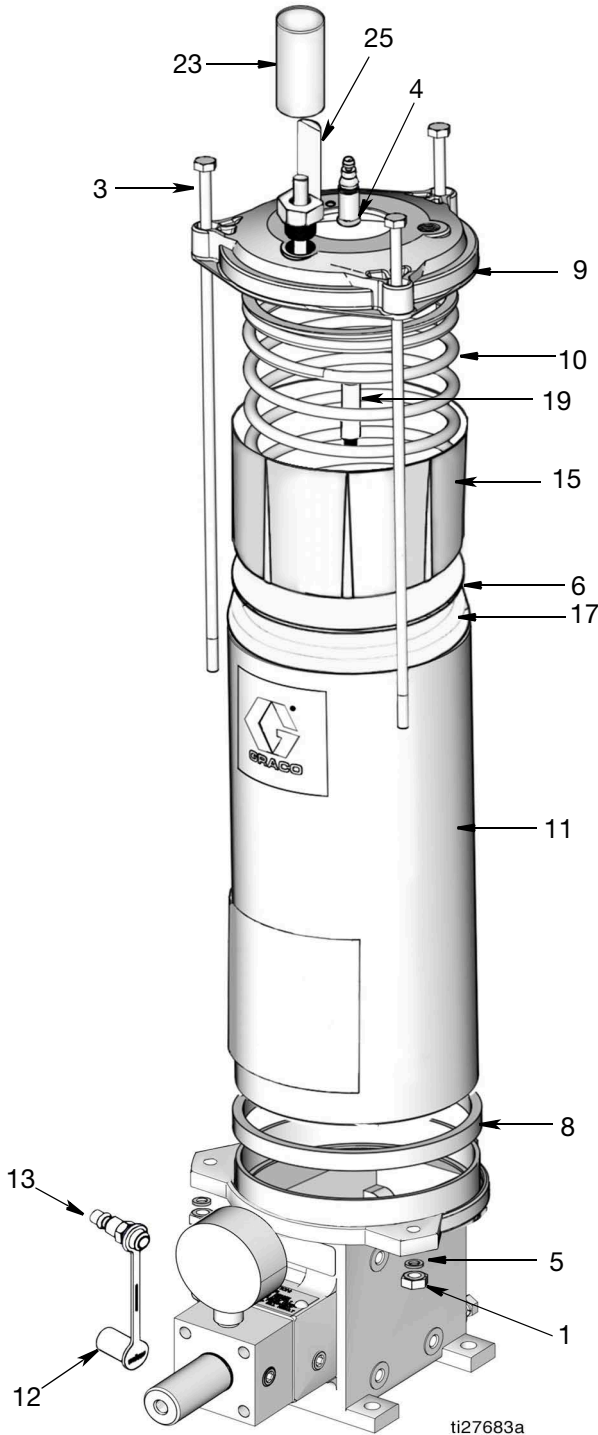

Ref	Part No.	Description	Qty.
	1	NUT, 5/16-18 hex	3
	2	NUT, elastic lock 5/16-18 hex (not shown)	1
	3#	ROD, tie, reservoir	3
	4	RING, retainer, 1/2 ID	1
	5#	WASHER, lock	3
	6	WASHER, reservoir (models 562896, 562897 only)	1
	8◆	GASKET, reservoir	1
	9	COVER, reservoir	1
	10	SPRING, follower	1
	11◆	RESERVOIR	1
	12 557373	CAP, dust fill stud	1
	13 557374	STUD, fill stud assy 1/4 NPT	1
	14	PLATE, reservoir top (not shown)	1
	15	CUP, follower	1
	17	CUP, follower, reservoir	1
	18	WASHER, spacer (models 562898, 562899 only)	1
	19	CABLE, indicator	1
	22	SCREW, drive (models 562898, 562899 only)	1
	23	CAP, protective Moduflo (models 562898, 562899 only)	1
	24	CLIP, indicator 12lb, 20 lb (models 562898, 562899 only)	1
	25 563334	INDICATOR, level assy 5lb (model 562898 only)	1
	563335	BODY, indicator assy 20 lb (model 562899 only)	1
◆ Included in one of the following kits:			
	562902	KIT, reservoir replacement, 12 lb, plastic (model 562896 only)	
	562903	KIT, reservoir replacement, 20 lb, plastic (model 562897 only)	
	564270	KIT, reservoir replacement, 12 lb, metal (model 562898 only)	
	564271	KIT, reservoir replacement, 12 lb, metal (model 562899 only)	
# Included in one of the following kits			
	258286	KIT, tie rod (models 562896, 562898 only)	
	258285	KIT, tie rod (models 562897, 562899 only)	

Parts

Oil Reservoir Models: 562892, 562893, 562894, 562895

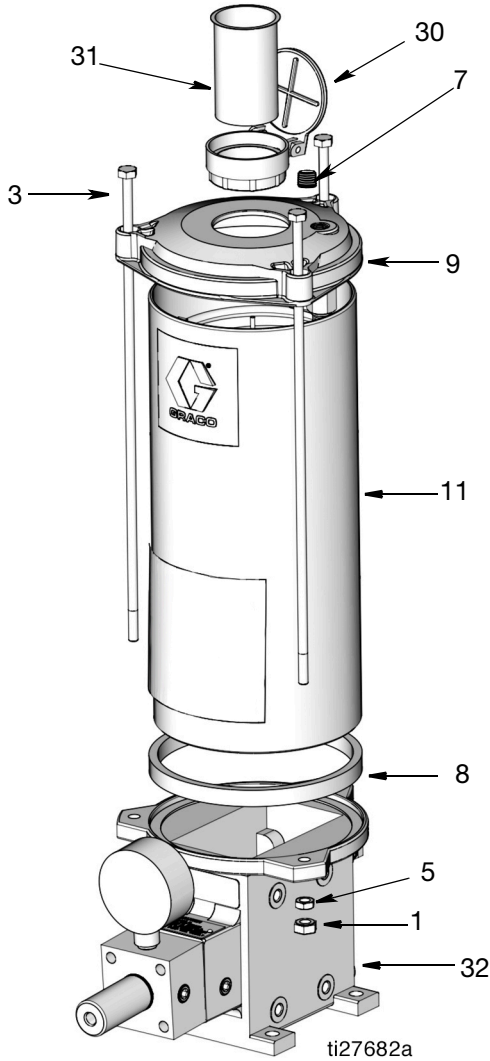

Ref. No.	Part No.	Description	Qty.
1#		NUT, 5/16-18 hex	3
3#		ROD, tie, reservoir	3
5#		WASHER, lock	3
7		PLUG, dryseal 1/4 nptf	2
8◆		GASKET, reservoir	1
9		COVER, reservoir	1
11◆		RESERVOIR	1
30	557797	CAP, fill, reservoir	1
31	557799	SCREEN, filter	1
32	563380	PUMP, assembly	1

- ◆ Included in one of the following kits:
 - 562902 KIT, reservoir replacement, 12 lb, plastic (model 562892 only)
 - 562903 KIT, reservoir replacement, 20 lb, plastic (model 562893 only)
 - 564270 KIT, reservoir replacement, 12 lb, metal (model 562894 only)
 - 564271 KIT, reservoir replacement, 12 lb, metal (model 562895 only)

- # Included in one of the following kits
 - 258286 KIT, tie rod (models 562892, 562894 only)
 - 258285 KIT, tie rod (models 562893, 562895 only)

Overhead Supply Adapter Assembly 562908

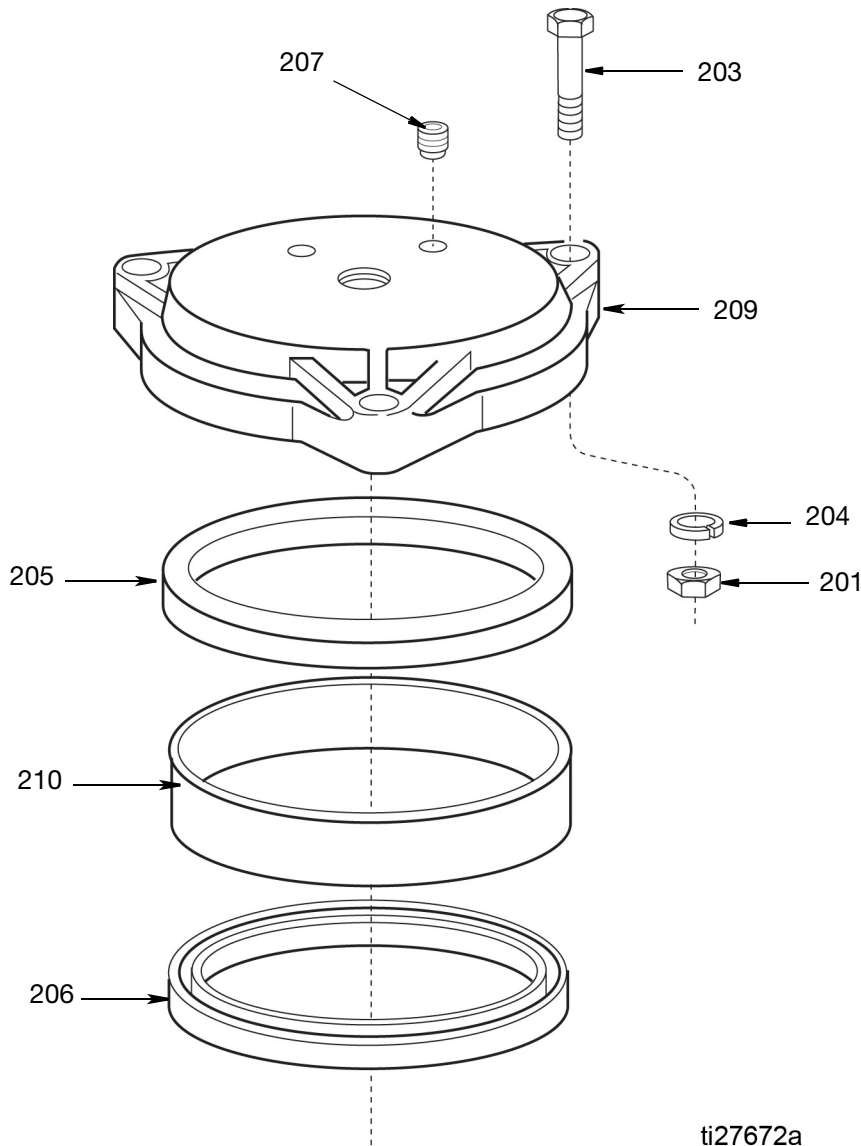

ti27672a

Ref	Part No.	Description	Qty
			.
201		NUT, 5/16 - 18 hex	3
202		PLUG, stl 1/2 pipe hex soc (not shown)	1
203		SCREW, hex hd cap, 5/16	3
204		WASHER, lock	3
205	557333	GASKET, 6, 12, 20 lb reservoir	1
206	557334	GASKET, lower reservoir	1
207		PLUG, dryseal 1/4 nptf	1
209		CAP, resv 12 lb bolt	1
210		TUBE, adapter	1

Pump Assembly: 563380

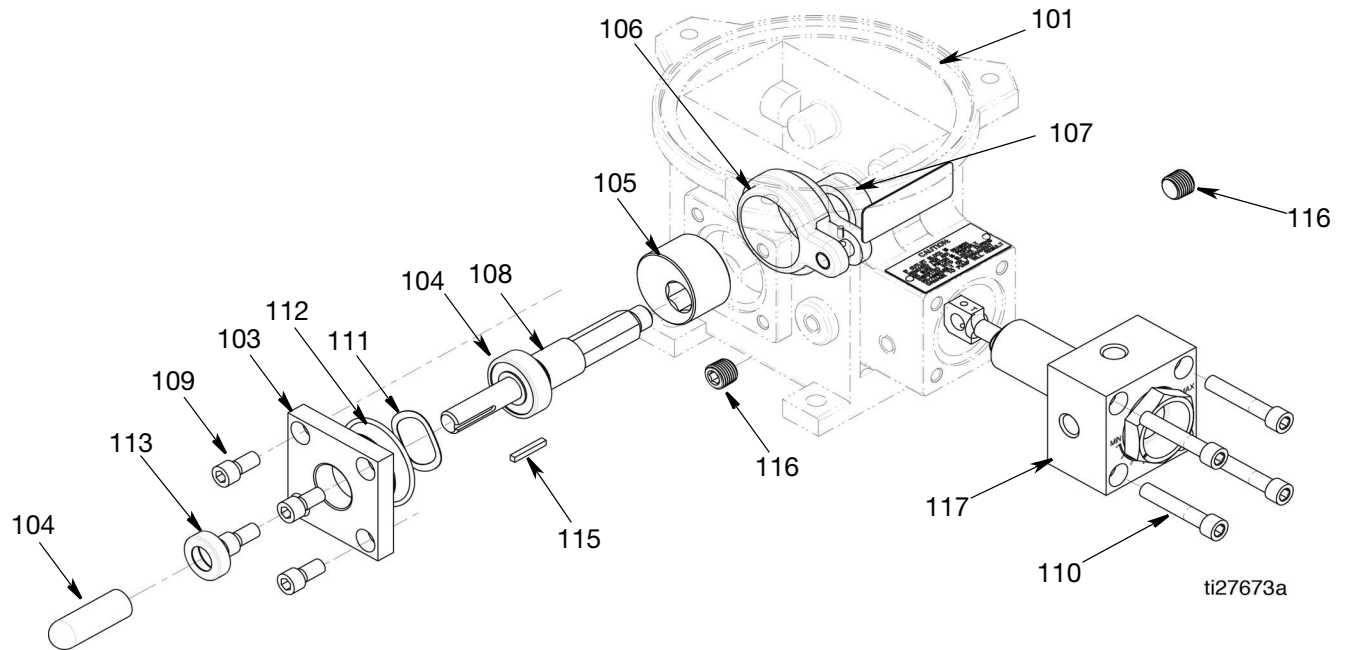
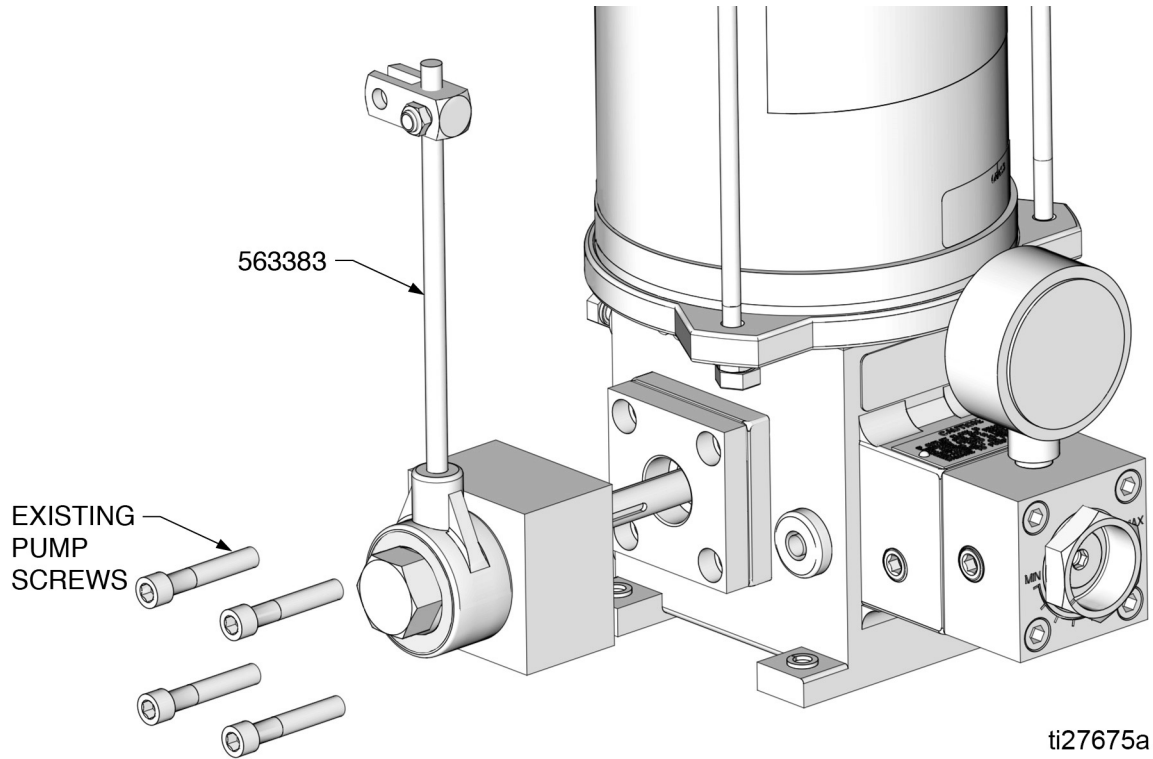

FIG. 19: Pump Body Assembly

Ref	Parts No.	Description	Qty
101	557644	BODY, pump	1
102	556361	BEARING, ball, 0.50 ID x 1.37 OD (not shown)	1
103		PLATE, end	1
104		SHAFT, assembly	1
105		CAM	1
106	560773	YOKE	1
107		SPACER, 0.75 ID x 0.344 long	1
108		SPACER, 0.75 ID x 0.969 long	1
109		SCREW, SHCS 5/16 -18 x 0.50	4
110		SCREW, SOC head cap, 5/16	4
111		WASHER	1
112		O-RING	1
113	556576	SEAL, lip, 0.50 ID, 1.00 OD, 0.25 W	1
114		CAP, protective	1
115		KEY, square, 0.125 x 0.875 lg	1
116	557391	PLUG, dryseal, 1/4 NPTF	3
117		PUMP, block manifold assembly	1

Clutch Drive Assembly: 563383



Lube Master Pump Package

Ref. No.	Part No.	Description	Qty	Ref. No.	Part No.	Description	Qty
301	557271	MOTOR, 115/230 volt, single-phase, 1/2 hp, 1725 rpm				SCREW, cap, hex hd (models 563388, 563389)	8
	557270	MOTOR, 230/460 volt, three-phase, 1/2 hp, 1725 rpm		307d		SCREW, 3/8-16 x 7/8 hex hd (models 563386, 563387)	4
	557272	MOTOR, 115/230 volt, single-phase, 1/2 hp, 1140 rpm		307f		SCREW, hex hd cap, 5/15 (models 563388, 563389) (not shown)	4
	557273	MOTOR, 230/460 volt, three-phase, 1/2 hp, 1175 rpm		307g		SCREW, #10-32 x 3/8 rd hd mach	4
302	557713	GAUGE, liq 5,000 psi, 1/4 NPT b/m		307h		WASHER, #10 internal tooth lock	4
303	562892	RESERVOIR, plastic oil, 12 pt		307j		WASHER, 3/8 plain flat (models 563388, 563389) (not shown)	8
	562893	RESERVOIR, plastic oil, 20 pt		307k		WASHER, 5/16 plain flat (models 563388, 563389) (not shown)	4
	562894	RESERVOIR, metal, oil, 12 pt		307m		COUPLER, 5/8 x 1/2	1
	562895	RESERVOIR, metal, oil, 20 pt		307n		TAG, oil, fill (not shown)	1
	562896	RESERVOIR, plastic, grease, 12 lb		307p		LABEL, name serial (not shown)	1
	562897	RESERVOIR, plastic, grease, 20 lb		307r		GEAR REDUCER, 10:1 (models 563386, 563388)	1
	562898	RESERVOIR, metal, grease, 12 lb				GEAR REDUCER, 60:1, 56C flange (models 563387, 563389)	1
	562899	RESERVOIR, metal, grease, 20 lb		307t		GUARD, coupling, paint	1
	562908	RESERVOIR, power prime		307u		PLATE, mounting (models 563386, 563388)	1
304	563015	SWITCH, II 12 pt		307v		BRACKET, mtg (models 563388, 563389)	1
	563016	SWITCH, II, 20 pt		307w		SPACER, pump (models 563388, 563389)	4
	563317	SWITCH, II assy, 20 pt oil cyl		307y		SPACER, reducer (models 563386, 563387)	4
	563322	SWITCH, grease reservoir		307z		SCREW, 3/8-16 x 1.00 hex hd cap (models 563388, 563389)	4
305	563380	BODY, pump assy			15K616	LABEL, Caution*	
306	563383	CLUTCH, drive			16M768	LABEL, Warning, Entangle*	
307	563386	BASE, wall mtg 10:1					
	563387	BASE, wall mtg 60:1					
	563388	BASE, floor mtg 10:1					
	563389	BASE, floor mtg 60:1					
307a		WASHER, lock, 3/8	4				
307b		WASHER, lock	4				
307c		SCREW, cap hex hd (models 563386, 563387)	4				

*Replacement labels are available at no cost.

Lube Master Pump Package with Gear Reducer and Motor (Up to 20 lbs): Floor Mounting

563388 - Base, Floor Mounting 10:1

563389 - Base, Floor Mounting 60:1

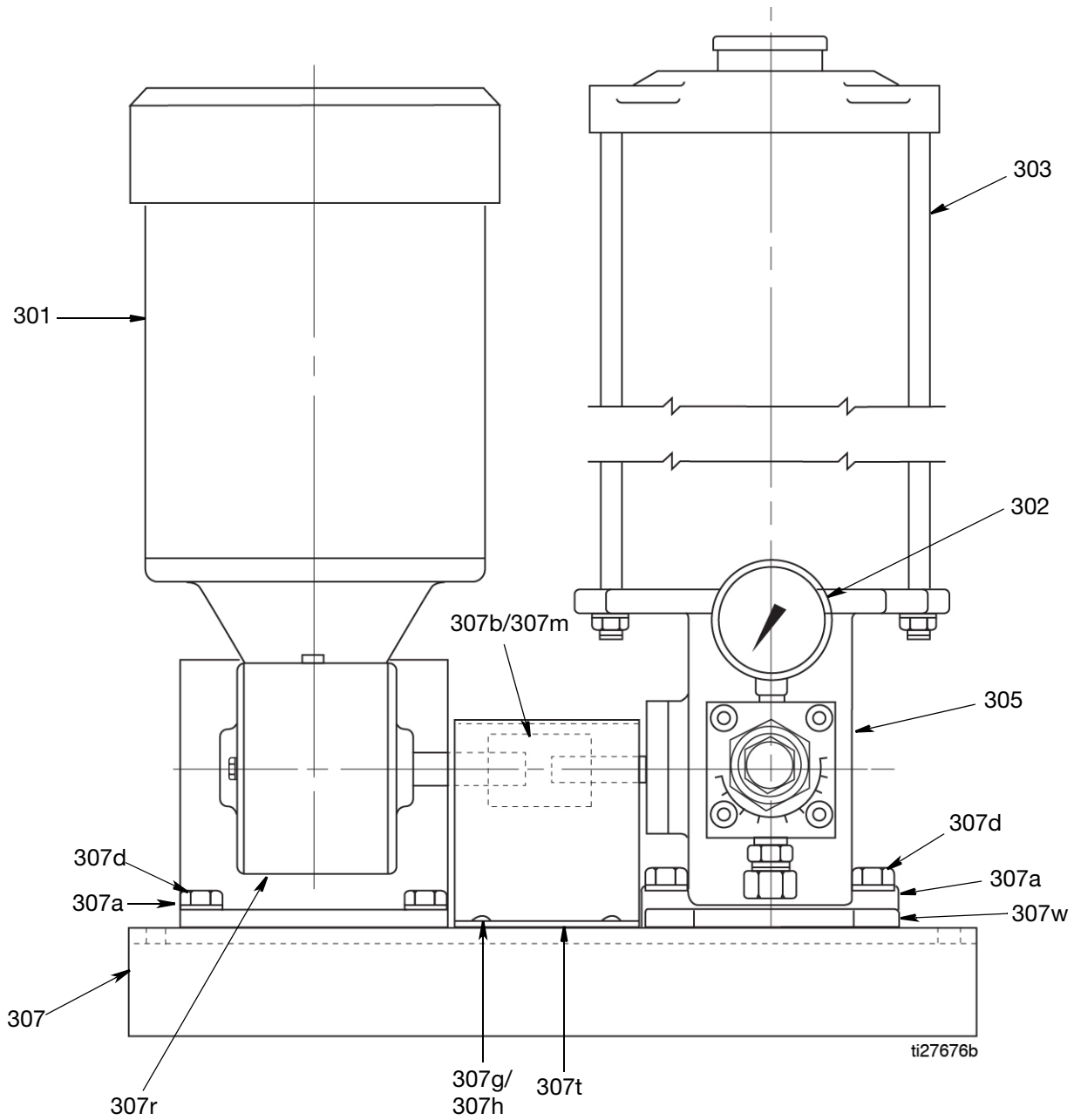

Lube Master Pump Package with Gear Reducer and Motor (Up to 20 lbs): Wall Mounting

563386 - Base, Wall Mounting 10:1

563387 - Base, Wall Mounting 60:1

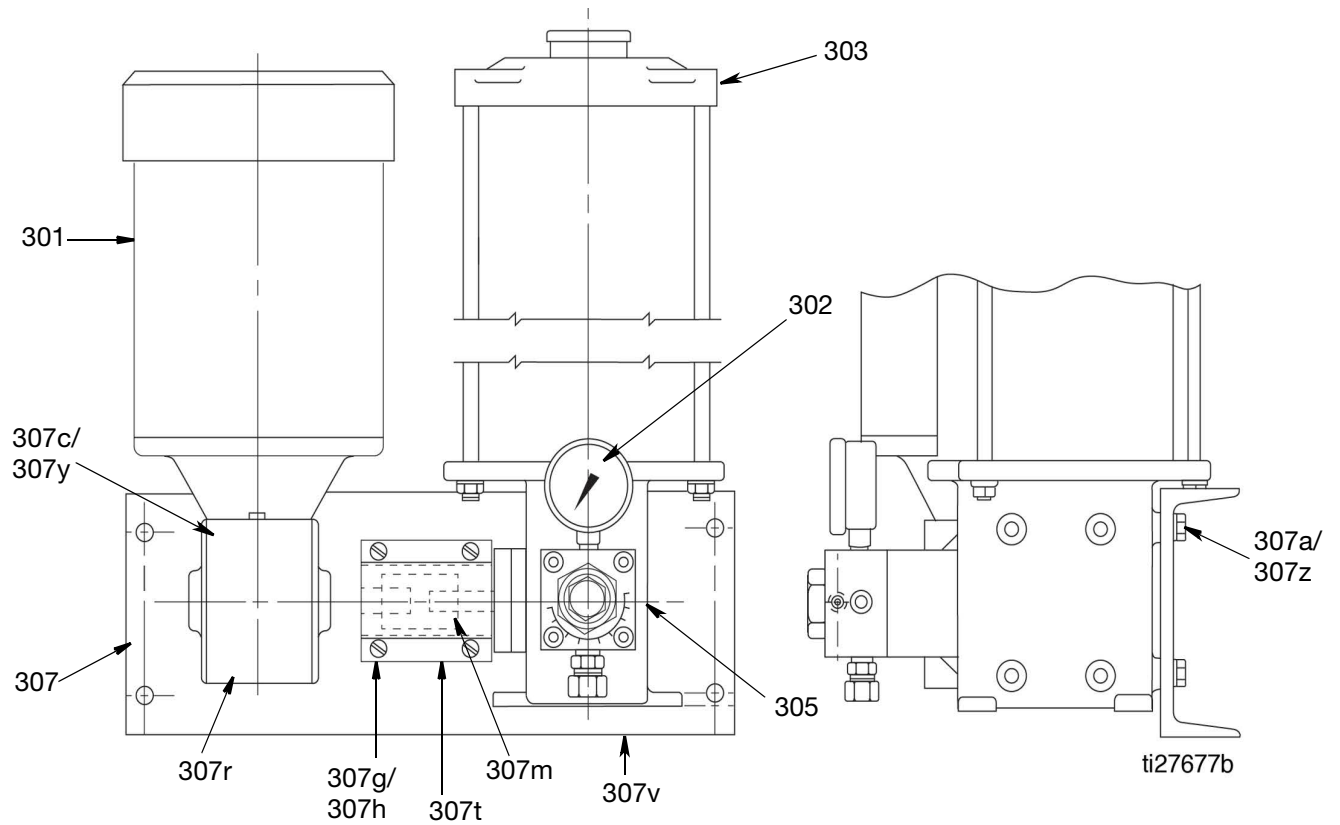

Oil Reservoir Model with 15 Amp Low-Level Switch Assembly

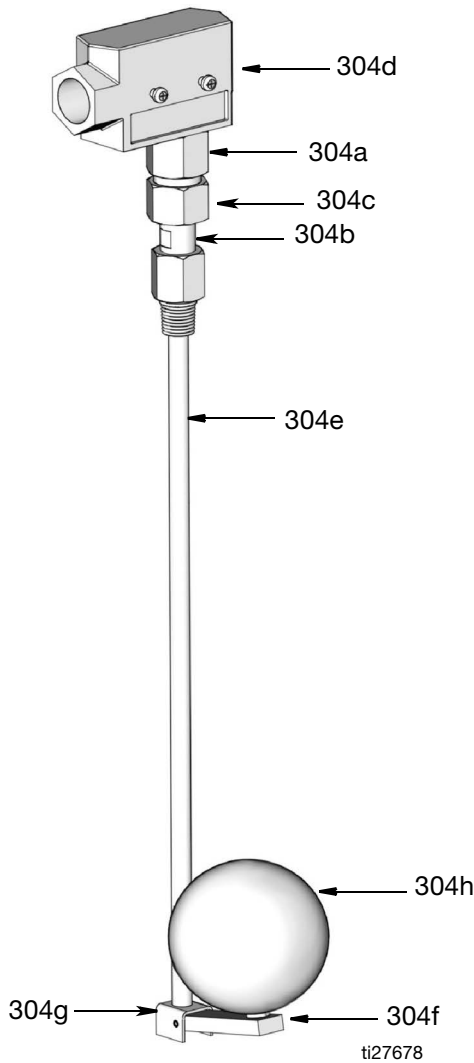

Ref	Part No.	Description	Qty
			.
304g		PIN, roll.093 dia 7/8 lg	1
304h		FLOAT, spherical	1
		WASHER, lock, int (not shown)	2
		ROD (not shown)	1
		SCEW, #8 - 32 x 1/2 slot phmach (not shown)	1

Oil Reservoir Model with 10 Watt Low-Level Switch Assembly

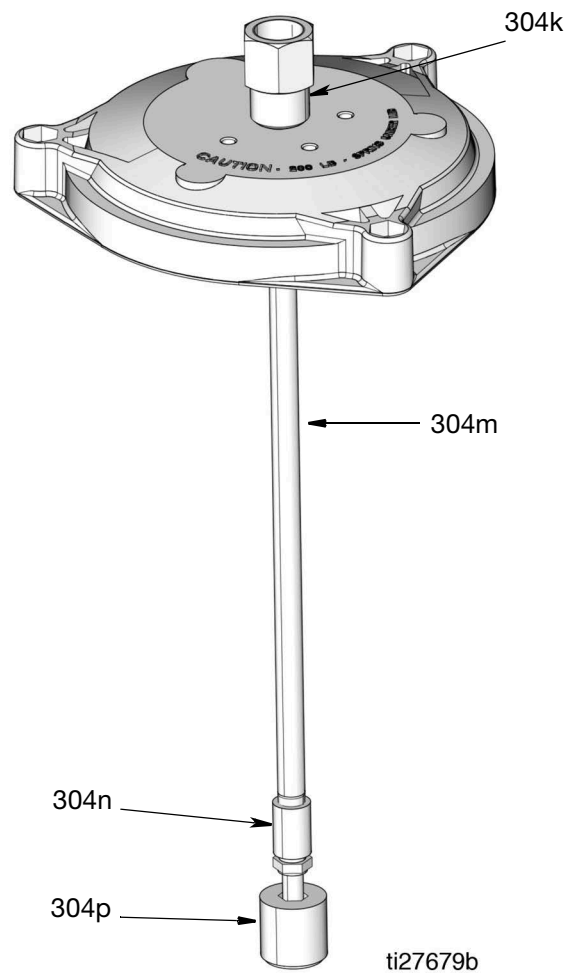

Ref	Part No.	Description	Qty
			.
304	563316	SWITCH, low-level assy 5 & 12 pt oil cyl	1
	563317	SWITCH, low-level assy 20 pt oil cyl	1
304a		ADAPTER, switch, ll	1
304b		ADAPTER, low-level	1
304c		FITTING, union, nut	1
304d		SWITCH, limit, spdt	1
304e		GUIDE, assy float rod	1
304f		ARM, ll float	1

Ref	Part No.	Description	Qty
			.
304	563015	SWITCH, low-level 12 pint	1
304	563016	SWITCH, low-level 20 pint	1
304k		ADAPTER	1
304m		COUPLER, 1/8 x 11"	1
		COUPLER, 1/8 x 18"	1
304n		COUPLING, stl 1/8 npt	1
304p		SWITCH, level mtg top	1

Grease Reservoir Model Low-Level Switch Assembly

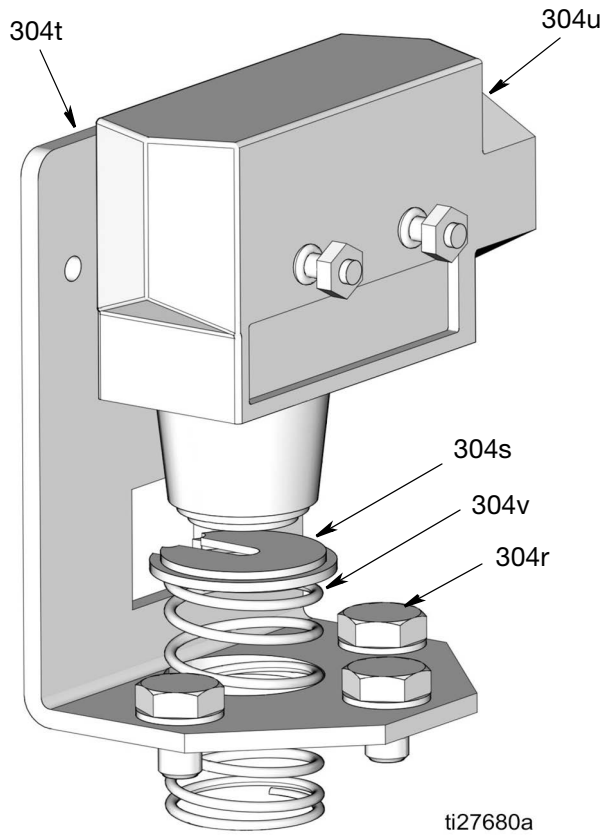

Ref	Part No.	Description	Qty
304	563322	SWITCH, low-level grease reservoir	.
304r		SCREW, 1/4-20 x 3/8 hex hd washer	3
304s		RETAINER, cup spr	1
304t		BRACKET, sw low lever paint	1
304u		SWITCH, limit spdt	1
304v		SPRING, primer filter	1

Dimensions

Reservoirs

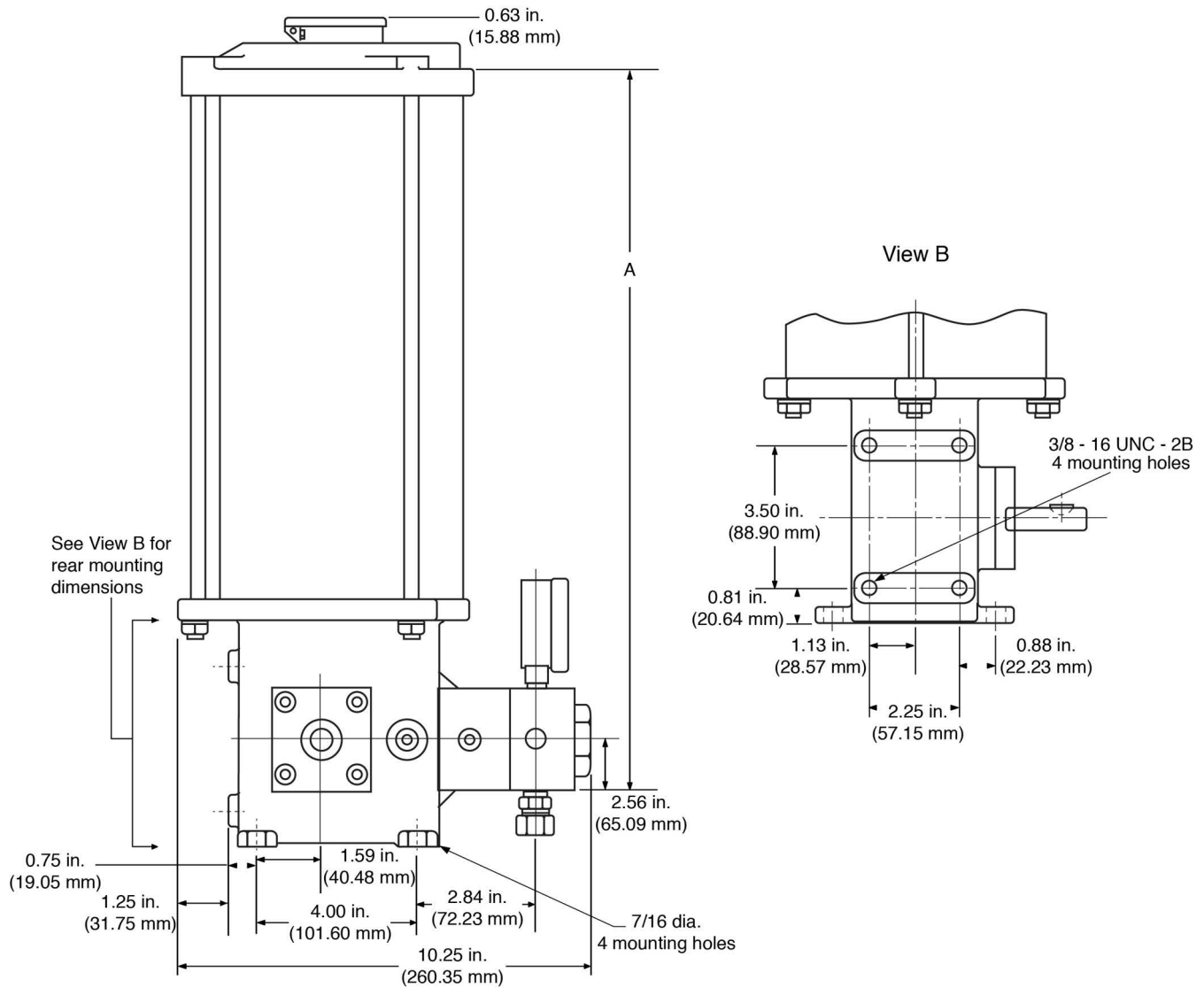

Reservoir Size	A- Dimension	
	Inches	MM
12 Pint Oil	19.56	496.9
12 Lb. Grease		
20 Pint Oil	26.56	674.7
20 Lb. Grease		
Overhead Supply	7.66	194.5

Reservoirs

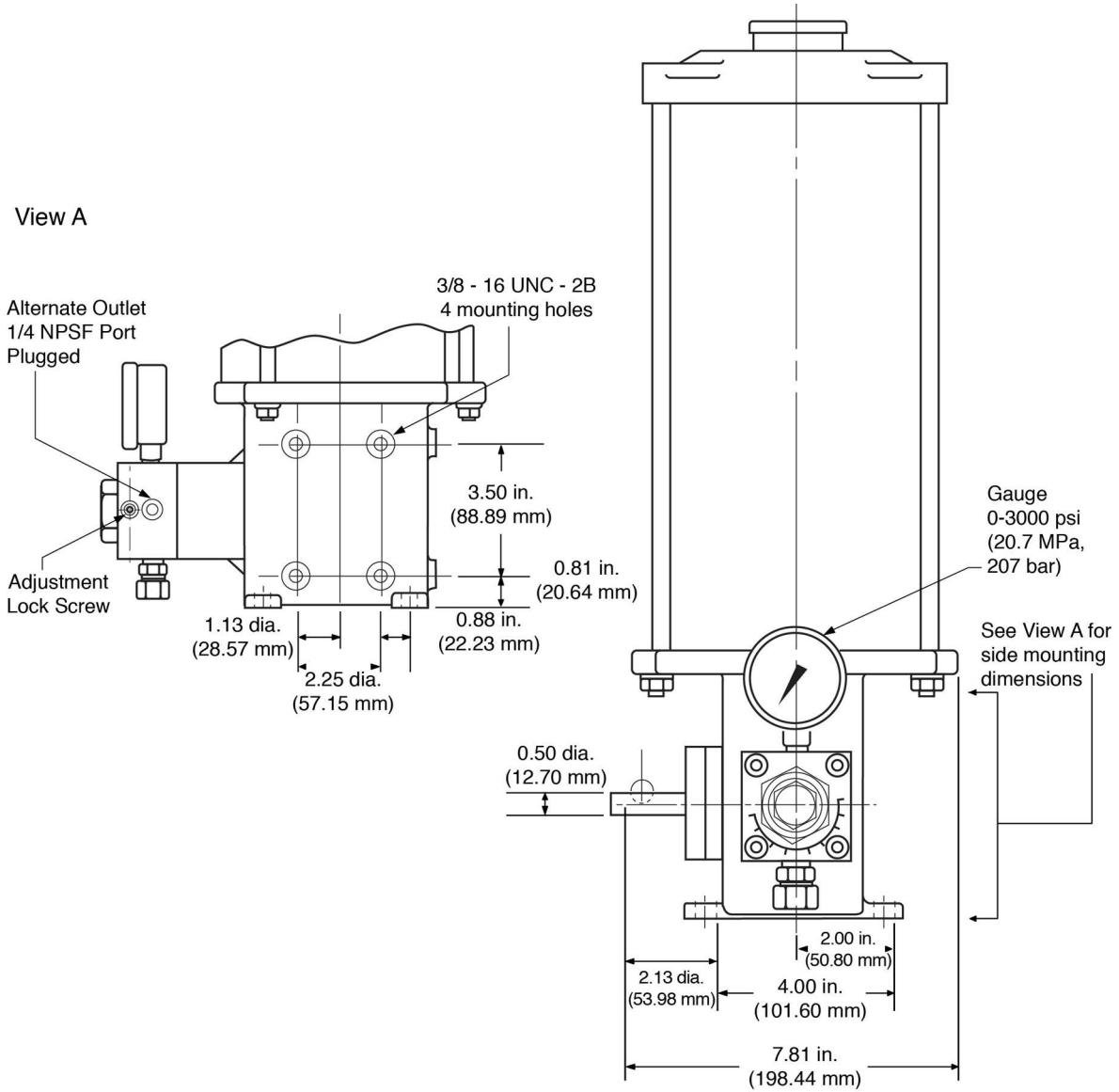

Reservoir Size	A- Dimension	
	Inches	MM
12 Pint Oil	19.56	496.9
12 Lb. Grease		
20 Pint Oil	26.56	674.7
20 Lb. Grease		

Clutch Drive

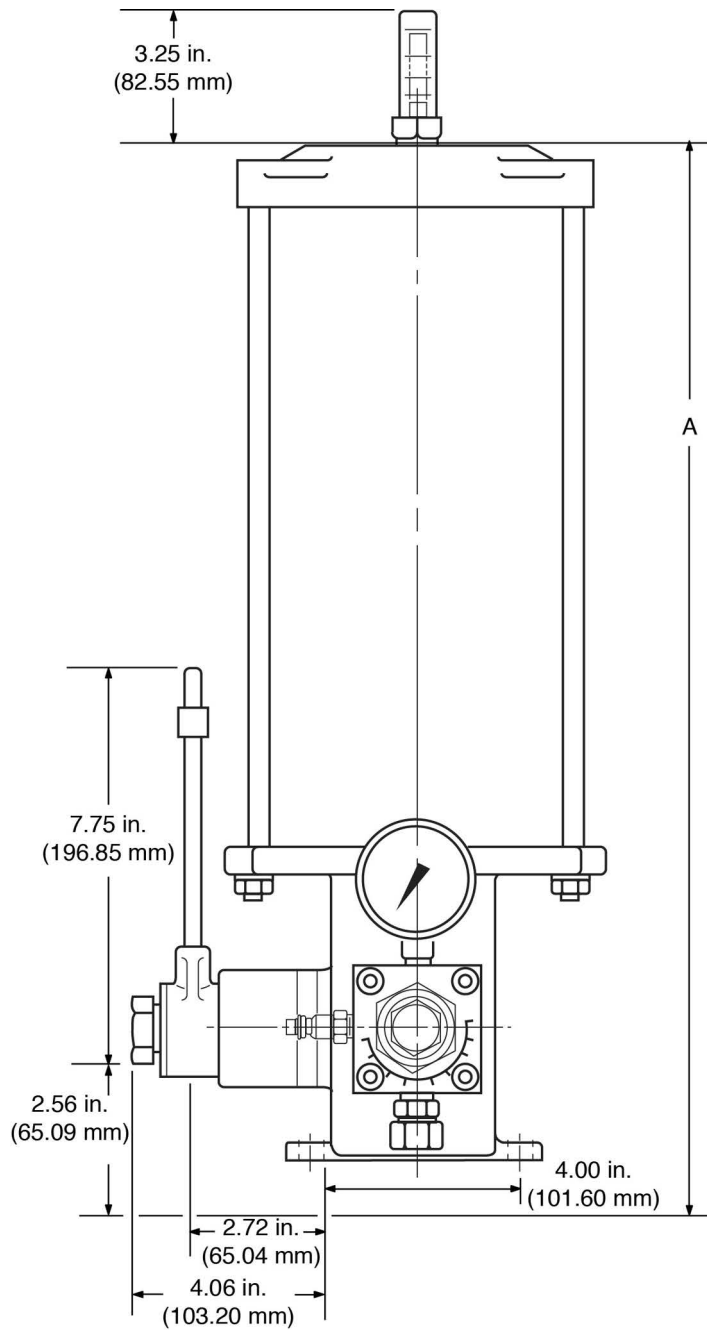

Reservoir Size	A- Dimension	
	Inches	MM
12 Pint Oil	19.56	496.9
12 Lb. Grease		
20 Pint Oil	26.56	674.7
20 Lb. Grease		

Clutch Drive

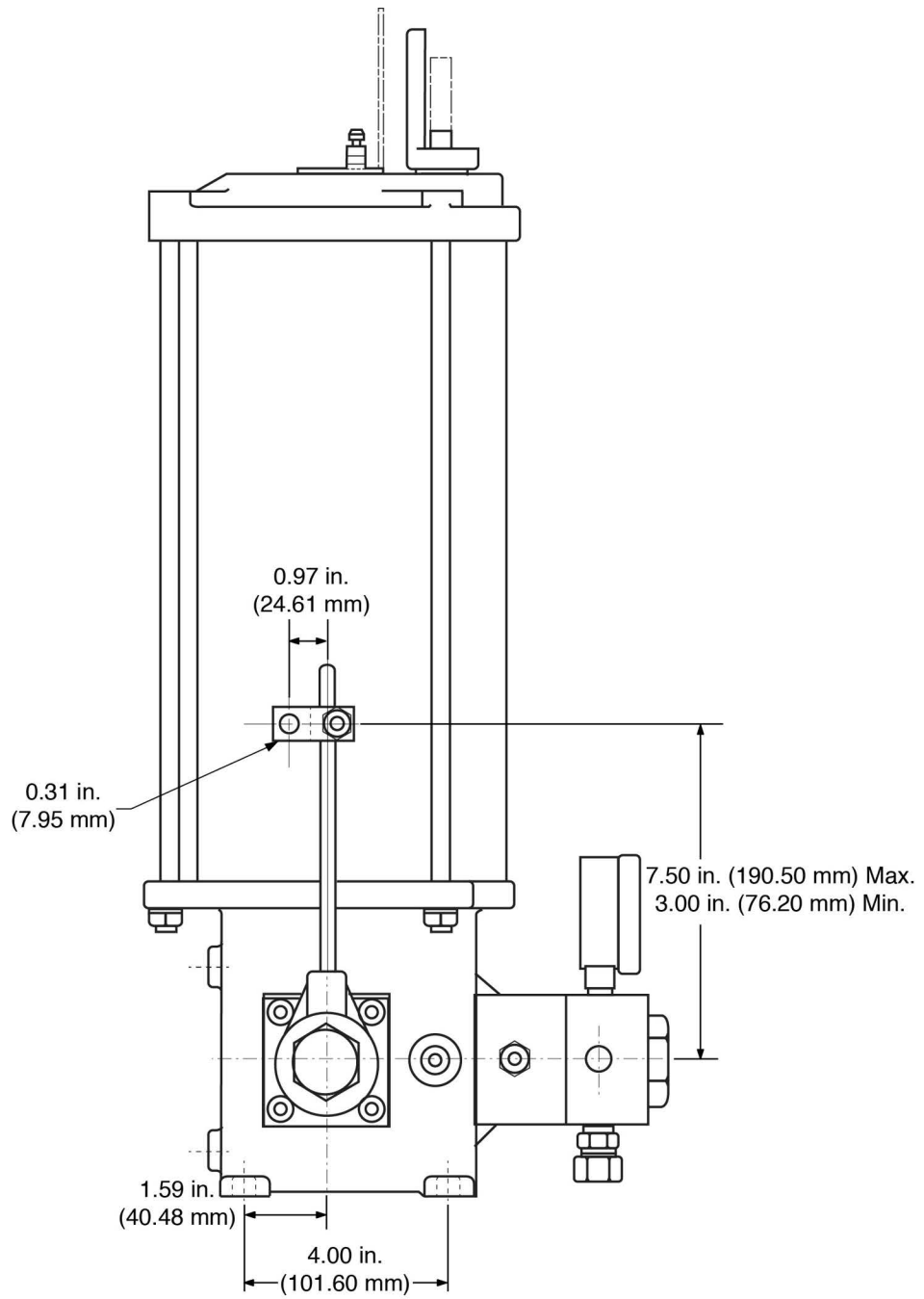

Lube Master (Up to 20lbs): Wall Mounting

Inches (mm)

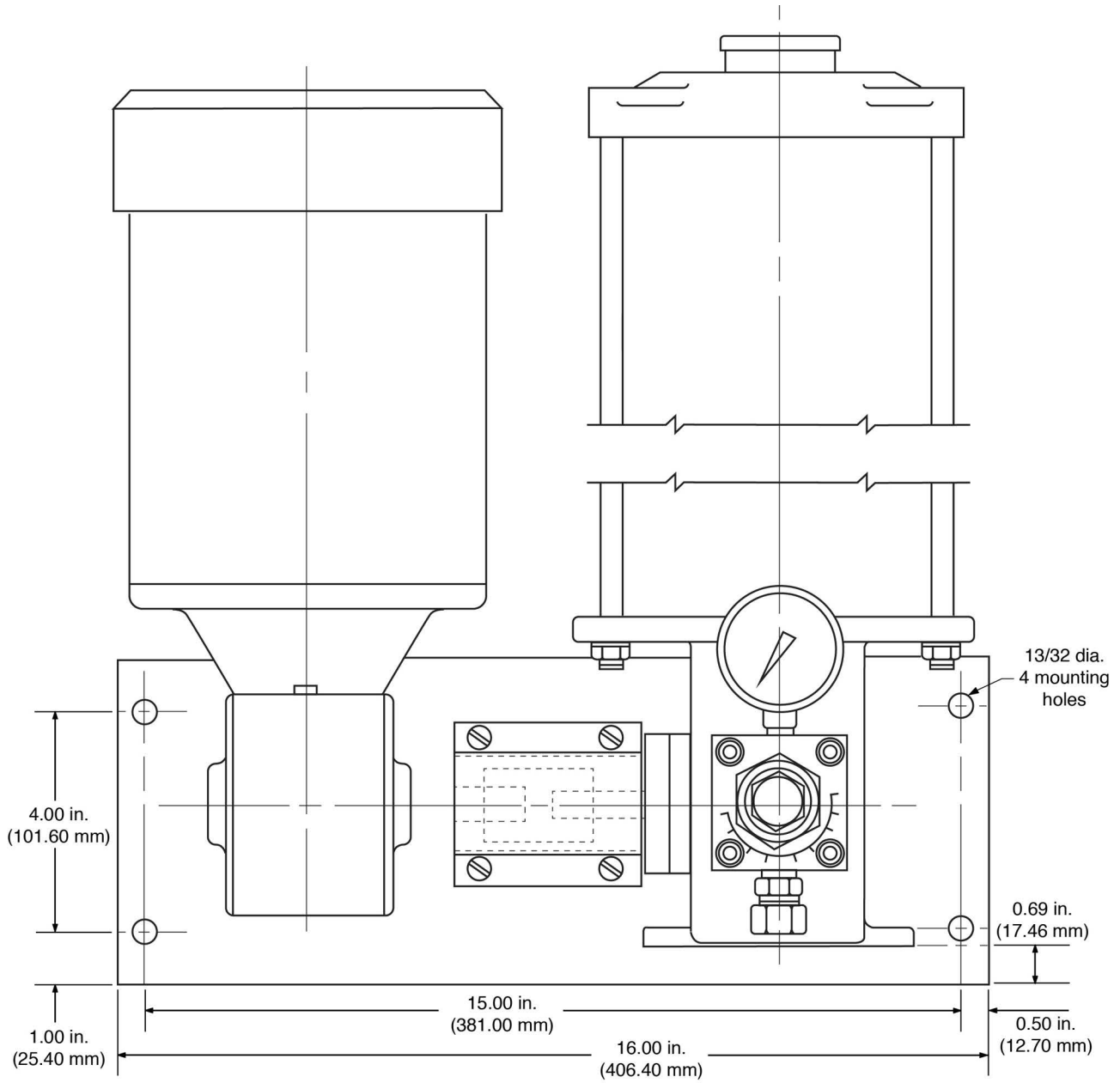

Lube Master (Up to 20lbs): Floor Mounting

Inches (mm)

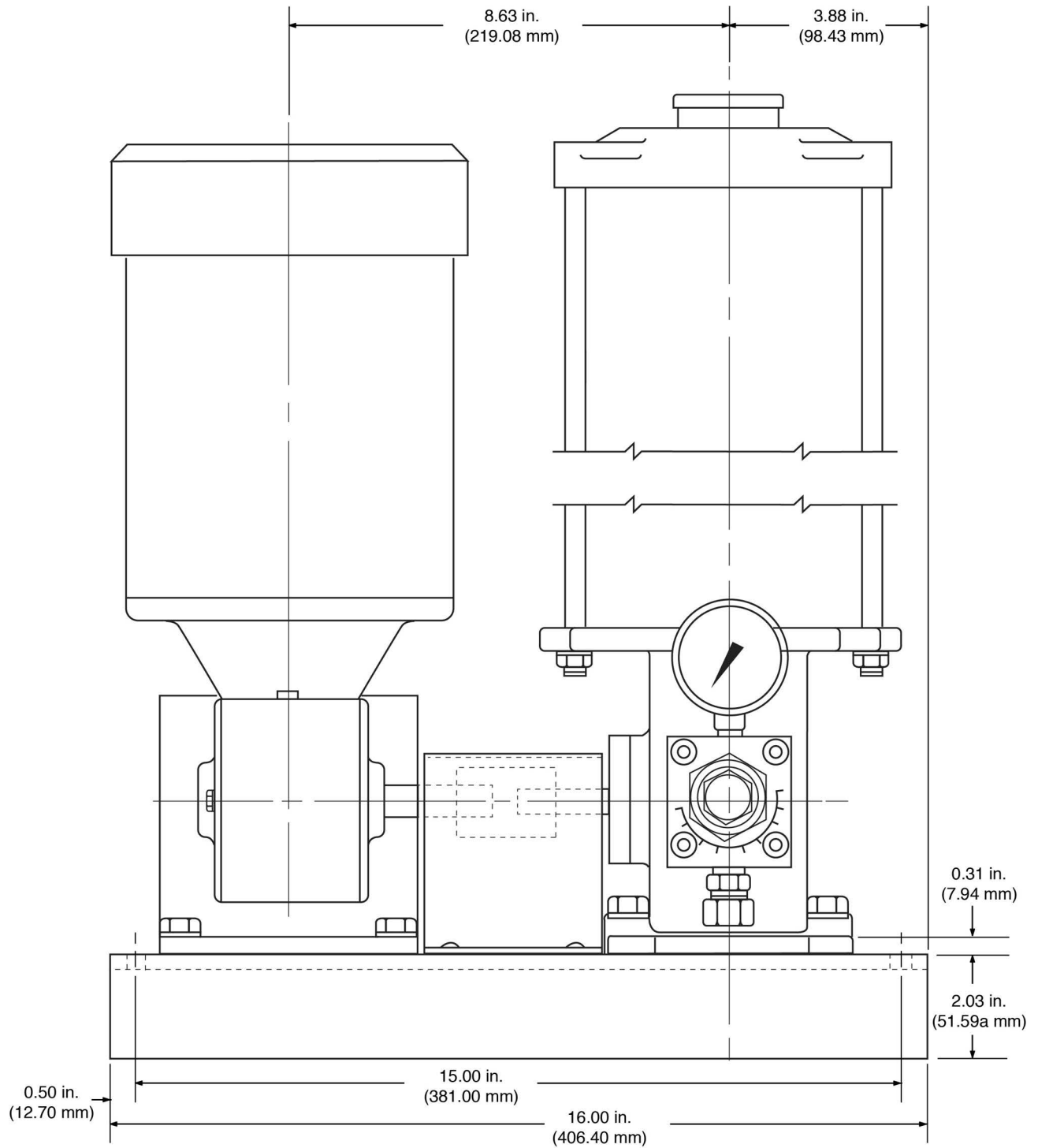

Lube Master (Up to 20lbs)

Inches (mm)

WALL MOUNTING

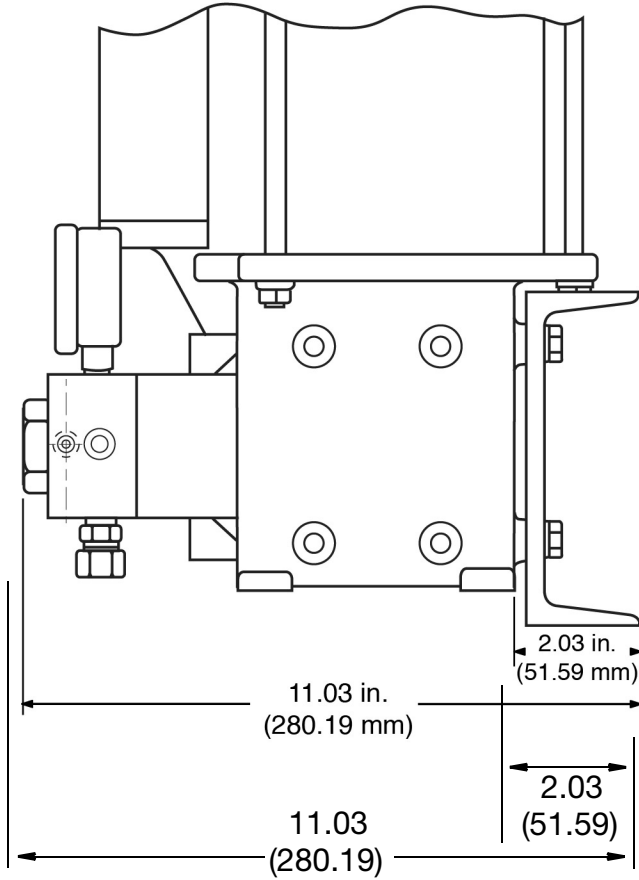

FLOOR MOUNTING

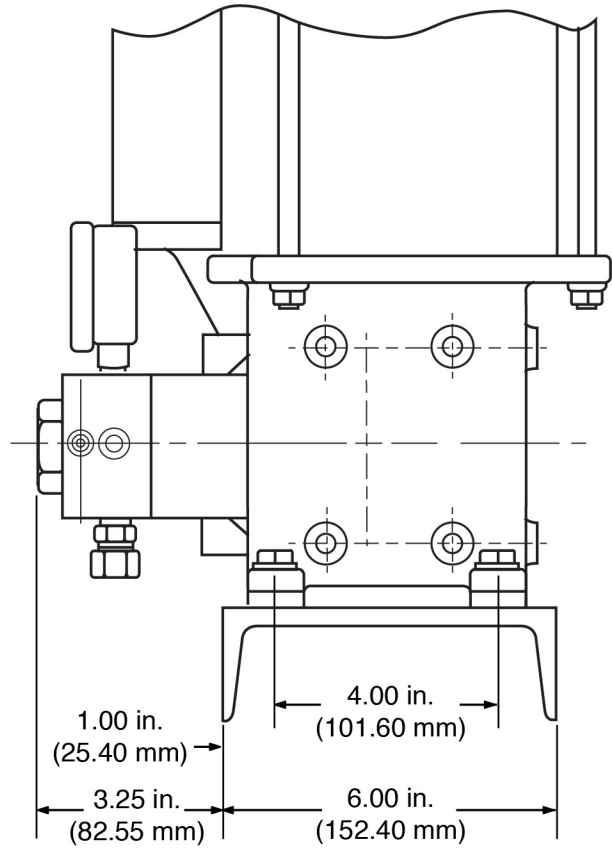

Technical Specifications

Lube Master® Floor Mount or Wall Mount Pump Package		
	US	Metric
Pump Data		
Maximum fluid working pressure	5,000 psi	34 MPa, 340 bar
Max Torque @ Rated Max Pressure	27 ft-lbs	36.61 N.m
Output Range	0.010 - 8.75 in. ³ per min	0.1639 - 143.41 cm ³ per min
Output per Stroke	0.010 - 0.050 in. ³	0.1639 - 0.8195 cm ³
Cycle Rate	1 - 175 strokes per minute	
Motorized Pump		
Gear Ratios	10:1 and 60:1 floor or wall mount	
Output Range	0.19 - 8.62 in. ³ per min	3.114 - 141.28 cm ³ per min
Clutch Drive Pump		
Cycle Rate	5 - 150 impulses per min	
Degrees of Throw	12° to 60°	
Output Range	0.100 - 75 in. ³ per hr	1.639 - 1229.25 cm ³ per hr
Lubricants	Oil or Grease	
Reservoirs		
Material	Plastic or Metal	
Reservoir Capacities		
Oil	12 pint and 20 pint	5.68L and 9.46L
Grease	12 lb. and 20 lb.	5.44 kg and 9.07 kg
Operating Temperatures		
Reservoirs		
*Plastic	35°F to 135°F	1.7°C to 57.2°C
*Metal	20°F to 150°F	-6.7°C to 65.6°C
Oil	20°F to 150°F	-6.7°C to 65.6°C
Grease		
**NLGI #1	20°F to 150°F	-6.7°C to 65.6°C
**NLGI #2	40°F to 150°F	4.44C to 65.6°C
Options		
Low-Level (Ordering Code)		
Code D - Pick 2 Code D - Pick 3	SPTD, 15 A, @ 125, 250, 480 VAC; 1/2 A @ 125 VDC; 1/4 A @ 250 VDC	
Code D - Pick 5 Code D - Pick 6	SPST, 10 W @ 120 VAC	

Lube Master® Floor Mount or Wall Mount Pump Package		
	US	Metric
Motors (56 C-face)	115/230 V 1/2 HP single phase 60 Hz 1725 RPM, T.E. Full load running current 115 V, 7.4 A; 230 V, 3.7 A. Inrush at 115 V 49 A; 230 V 24.5 A.	
	230/460 V 1/2 HP three phase 60 Hz 1725 RPM, T.E. Full load running current 230 V, 2 A; 460 V, 1 A. Inrush at 230 V 12.2 A; 460 V 6.1 A.	
	115/230 V 1/2 HP single phase 60 Hz 1140 RPM, T.E. Full load running current 115 V, 7.8 A; 230 V, 3.9 A. Inrush at 115 V 49 A; 230 V 24.5 A.	
	230/460 V 1/2 HP three phase 60 Hz 1175 RPM, T.E. Full load running current 230 V, 2 A; 460 V, 1.0 A.	
Sound pressure level (Measured at 0.5 m from unit)	89.0 dB(A)	

*These recommended operating temperatures are based on materials used in construction of the pump and reservoir only.

**The grease must be pumpable at the lowest anticipated operating temperature.

California Proposition 65

 **WARNING:** This product can expose you to chemicals known to the State of California to cause cancer and birth defects or other reproductive harm. For more information, go to www.P65warnings.ca.gov.

Graco Standard Warranty

Graco warrants all equipment referenced in this document which is manufactured by Graco and bearing its name to be free from defects in material and workmanship on the date of sale to the original purchaser for use. With the exception of any special, extended, or limited warranty published by Graco, Graco will, for a period of twelve months from the date of sale, repair or replace any part of the equipment determined by Graco to be defective. This warranty applies only when the equipment is installed, operated and maintained in accordance with Graco's written recommendations.

This warranty does not cover, and Graco shall not be liable for general wear and tear, or any malfunction, damage or wear caused by faulty installation, misapplication, abrasion, corrosion, inadequate or improper maintenance, negligence, accident, tampering, or substitution of non-Graco component parts. Nor shall Graco be liable for malfunction, damage or wear caused by the incompatibility of Graco equipment with structures, accessories, equipment or materials not supplied by Graco, or the improper design, manufacture, installation, operation or maintenance of structures, accessories, equipment or materials not supplied by Graco.

This warranty is conditioned upon the prepaid return of the equipment claimed to be defective to an authorized Graco distributor for verification of the claimed defect. If the claimed defect is verified, Graco will repair or replace free of charge any defective parts. The equipment will be returned to the original purchaser transportation prepaid. If inspection of the equipment does not disclose any defect in material or workmanship, repairs will be made at a reasonable charge, which charges may include the costs of parts, labor, and transportation.

THIS WARRANTY IS EXCLUSIVE, AND IS IN LIEU OF ANY OTHER WARRANTIES, EXPRESS OR IMPLIED, INCLUDING BUT NOT LIMITED TO WARRANTY OF MERCHANTABILITY OR WARRANTY OF FITNESS FOR A PARTICULAR PURPOSE.

Graco's sole obligation and buyer's sole remedy for any breach of warranty shall be as set forth above. The buyer agrees that no other remedy (including, but not limited to, incidental or consequential damages for lost profits, lost sales, injury to person or property, or any other incidental or consequential loss) shall be available. Any action for breach of warranty must be brought within two (2) years of the date of sale.

GRACO MAKES NO WARRANTY, AND DISCLAIMS ALL IMPLIED WARRANTIES OF MERCHANTABILITY AND FITNESS FOR A PARTICULAR PURPOSE, IN CONNECTION WITH ACCESSORIES, EQUIPMENT, MATERIALS OR COMPONENTS SOLD BUT NOT MANUFACTURED BY GRACO. These items sold, but not manufactured by Graco (such as electric motors, switches, hose, etc.), are subject to the warranty, if any, of their manufacturer. Graco will provide purchaser with reasonable assistance in making any claim for breach of these warranties.

In no event will Graco be liable for indirect, incidental, special or consequential damages resulting from Graco supplying equipment hereunder, or the furnishing, performance, or use of any products or other goods sold hereto, whether due to a breach of contract, breach of warranty, the negligence of Graco, or otherwise.

FOR GRACO CANADA CUSTOMERS

The Parties acknowledge that they have required that the present document, as well as all documents, notices and legal proceedings entered into, given or instituted pursuant hereto or relating directly or indirectly hereto, be drawn up in English. Les parties reconnaissent avoir convenu que la rédaction du présente document sera en Anglais, ainsi que tous documents, avis et procédures judiciaires exécutés, donnés ou intentés, à la suite de ou en rapport, directement ou indirectement, avec les procédures concernées.

Graco Information

For the latest information about Graco products, visit www.graco.com.

For patent information, see www.graco.com/patents.

TO PLACE AN ORDER, contact your Graco distributor or call to identify the nearest distributor.

Phone: 612-623-6928 **or Toll Free:** 1-800-533-9655, **Fax:** 612-378-3590

All written and visual data contained in this document reflects the latest product information available at the time of publication. Graco reserves the right to make changes at any time without notice.

Original instructions. This manual contains English. MM 3A2781

Graco Headquarters: Minneapolis

International Offices: Belgium, China, Japan, Korea

GRACO INC. AND SUBSIDIARIES • P.O. BOX 1441 • MINNEAPOLIS MN 55440-1441 • USA
Copyright 2017, Graco Inc. All Graco manufacturing locations are registered to ISO 9001.

www.graco.com

Revision E, February 2024