

# Z-Pump Elite Series

3A8563D

EN

***For pumping highly abrasive plural component materials. For professional use only.***

*3500 psi (24 MPa, 241 bar) Maximum Working Pressure*

See page 2 for model information.



## **Important Safety Instructions**

Read all warnings and instructions in this manual before using the equipment.  
Save these instructions.

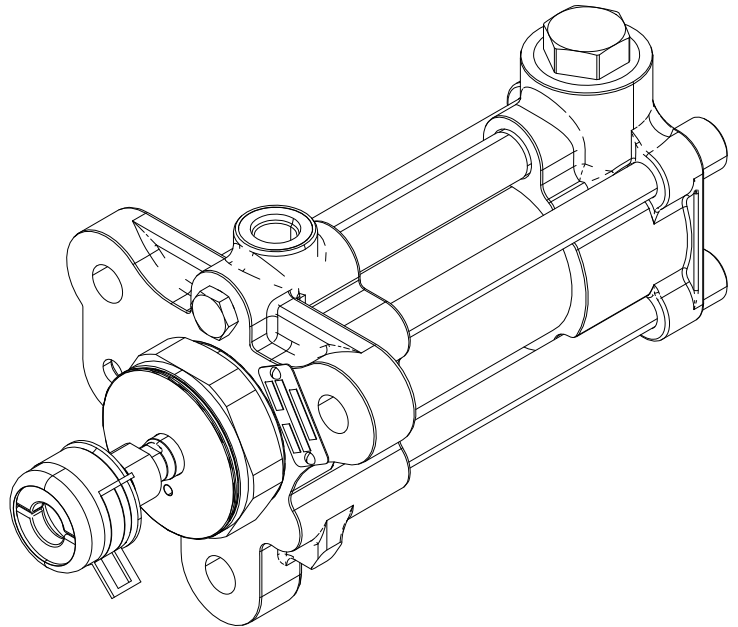

# Contents

<b>Related Manuals</b> .....	<b>2</b>	<b>Parts</b> .....	<b>19</b>
<b>Models</b> .....	<b>2</b>	Table 1 .....	19
<b>Warnings</b> .....	<b>3</b>	Complete Pump .....	19
<b>Important Isocyanate (ISO) Information</b> .....	<b>6</b>	Table 2 .....	24
Isocyanate Conditions .....	6	Various Kits .....	24
Keep Components A and B Separate .....	6	Table 3 .....	25
Moisture Sensitivity of Isocyanates .....	6	Seal Kits .....	25
Changing Materials .....	7	Table 4 .....	28
<b>Component Identification</b> .....	<b>8</b>	Displacement Rod Kits .....	28
<b>Operation</b> .....	<b>9</b>	Table 5 .....	31
Pressure Relief Procedure .....	9	Check Valve Kits .....	31
Flushing .....	9	Table 6 .....	33
<b>Maintenance</b> .....	<b>10</b>	O-Ring Inlet Kit, All Pump Sizes .....	33
<b>Repair</b> .....	<b>11</b>	<b>Dimensions</b> .....	<b>34</b>
Required Tools .....	11	<b>Technical Specifications</b> .....	<b>35</b>
Inlet Housing Disassembly .....	11	<b>California Proposition 65</b> .....	<b>35</b>
Inlet Housing Assembly .....	12	<b>Graco Standard Warranty</b> .....	<b>36</b>
Pump Disassembly .....	14		
Pump Assembly .....	16		

## Related Manuals

Manual in English	Description
3A6165	EFR Instructions - Parts
313997	HFR Setup - Operation
3A1961	HFR for NVH Foam - Modular Setup - Operation

## Models





Model	Pump Size
<b>L020S8</b>	20cc
<b>L040S8</b>	40cc
<b>L080S8</b>	80cc
<b>L100S8</b>	100cc
<b>L120S8</b>	120cc
<b>L160S8</b>	160cc

# Warnings

The following warnings are for the setup, use, grounding, maintenance, and repair of this equipment. The exclamation point symbol alerts you to a general warning and the hazard symbols refer to procedure-specific risks. When these symbols appear in the body of this manual or on warning labels, refer back to these Warnings. Product-specific hazard symbols and warnings not covered in this section may appear throughout the body of this manual where applicable.

 <h2 style="margin: 0;">WARNING</h2>	
   	<p><b>FIRE AND EXPLOSION HAZARD</b></p> <p>Flammable fumes, such as solvent and paint fumes, in <b>work area</b> can ignite or explode. Paint or solvent flowing through the equipment can cause static sparking. To help prevent fire and explosion:</p> <ul style="list-style-type: none"> <li>• Use equipment only in well-ventilated area.</li> <li>• Eliminate all ignition sources; such as pilot lights, cigarettes, portable electric lamps, and plastic drop cloths (potential static sparking).</li> <li>• Ground all equipment in the work area.</li> <li>• Never spray or flush solvent at high pressure.</li> <li>• Keep work area free of debris, including solvent, rags and gasoline.</li> <li>• Do not plug or unplug power cords, or turn power or light switches on or off when flammable fumes are present.</li> <li>• Use only grounded hoses.</li> <li>• Hold gun firmly to side of grounded pail when triggering into pail. Do not use pail liners unless they are anti-static or conductive.</li> <li>• <b>Stop operation immediately</b> if static sparking occurs or you feel a shock. Do not use equipment until you identify and correct the problem.</li> <li>• Keep a working fire extinguisher in the work area.</li> </ul>
    	<p><b>SKIN INJECTION HAZARD</b></p> <p>High-pressure fluid from dispensing device, hose leaks, or ruptured components will pierce skin. This may look like just a cut, but it is a serious injury that can result in amputation. <b>Get immediate surgical treatment.</b></p> <ul style="list-style-type: none"> <li>• Do not point dispensing device at anyone or at any part of the body.</li> <li>• Do not put your hand over the fluid outlet.</li> <li>• Do not stop or deflect leaks with your hand, body, glove, or rag.</li> <li>• Follow the <b>Pressure Relief Procedure</b> when you stop dispensing and before cleaning, checking, or servicing equipment.</li> <li>• Tighten all fluid connections before operating the equipment.</li> <li>• Check hoses and couplings daily. Replace worn or damaged parts immediately.</li> </ul>

# **WARNING**

 	<p><b>EQUIPMENT MISUSE HAZARD</b> Misuse can cause death or serious injury.</p> <ul style="list-style-type: none"> <li>• Do not operate the unit when fatigued or under the influence of drugs or alcohol.</li> <li>• Do not exceed the maximum working pressure or temperature rating of the lowest rated system component. See <b>Technical Specifications</b> in all equipment manuals.</li> <li>• Use fluids and solvents that are compatible with equipment wetted parts. See <b>Technical Specifications</b> in all equipment manuals. Read fluid and solvent manufacturer’s warnings. For complete information about your material, request Safety Data Sheets (SDSs) from distributor or retailer.</li> <li>• Do not leave the work area while equipment is energized or under pressure.</li> <li>• Turn off all equipment and follow the <b>Pressure Relief Procedure</b> when equipment is not in use.</li> <li>• Check equipment daily. Repair or replace worn or damaged parts immediately with genuine manufacturer’s replacement parts only.</li> <li>• Do not alter or modify equipment. Alterations or modifications may void agency approvals and create safety hazards.</li> <li>• Make sure all equipment is rated and approved for the environment in which you are using it.</li> <li>• Use equipment only for its intended purpose. Call your distributor for information.</li> <li>• Route hoses and cables away from traffic areas, sharp edges, moving parts, and hot surfaces.</li> <li>• Do not kink or over bend hoses or use hoses to pull equipment.</li> <li>• Keep children and animals away from work area.</li> <li>• Comply with all applicable safety regulations.</li> </ul>
 	<p><b>MOVING PARTS HAZARD</b> Moving parts can pinch, cut or amputate fingers and other body parts.</p> <ul style="list-style-type: none"> <li>• Keep clear of moving parts.</li> <li>• Do not operate equipment with protective guards or covers removed.</li> <li>• Equipment can start without warning. Before checking, moving, or servicing equipment, follow the <b>Pressure Relief Procedure</b> and disconnect all power sources.</li> </ul>
	<p><b>BURN HAZARD</b> Equipment surfaces and fluid that is heated can become very hot during operation. To avoid severe burns:</p> <ul style="list-style-type: none"> <li>• Do not touch hot fluid or equipment.</li> </ul>



# WARNING



## TOXIC FLUID OR FUMES HAZARD

Toxic fluids or fumes can cause serious injury or death if splashed in the eyes or on skin, inhaled or swallowed.

- Read Safety Data Sheets (SDSs) for handling instructions and to know the specific hazards of the fluids you are using, including the effects of long-term exposure.
- When spraying, servicing equipment, or when in the work area, always keep work area well-ventilated and always wear appropriate personal protective equipment. See **Personal Protective Equipment** warnings in this manual.
- Store hazardous fluid in approved containers, and dispose of it according to applicable guidelines.







## PERSONAL PROTECTIVE EQUIPMENT

Always wear appropriate personal protective equipment and cover all skin when spraying, servicing equipment, or when in the work area. Protective equipment helps prevent serious injury, including long-term exposure; inhalation of toxic fumes, mists or vapors; allergic reaction; burns; eye injury and hearing loss. This protective equipment includes but is not limited to:

- A properly fitting respirator, which may include a supplied-air respirator, chemically impermeable gloves, protective clothing and foot coverings as recommended by the fluid manufacturer and local regulatory authority.
- Protective eyewear and hearing protection.



# Important Isocyanate (ISO) Information

## Isocyanate Conditions

				
Spraying or dispensing fluids that contain isocyanates creates potentially harmful mists, vapors, and atomized particulates.				

- Read and understand the fluid manufacturer’s warnings and Safety Data Sheets (SDSs) to know specific hazards and precautions related to isocyanates.
- Use of isocyanates involves potentially hazardous procedures. Do not spray with this equipment unless you are trained, qualified, and have read and understood the information in this manual and in the fluid manufacturer’s application instructions and SDSs.
- Use of incorrectly maintained or mis-adjusted equipment may result in improperly cured material. Equipment must be carefully maintained and adjusted according to instructions in the manual.
- To prevent inhalation of isocyanate mists, vapors, and atomized particulates, everyone in the work area must wear appropriate respiratory protection. Always wear a properly fitting respirator, which may include a supplied-air respirator. Ventilate the work area according to instructions in the fluid manufacturer’s SDSs.
- Avoid all skin contact with isocyanates. Everyone in the work area must wear chemically impermeable gloves, protective clothing and foot coverings as recommended by the fluid manufacturer and local regulatory authority. Follow all fluid manufacturer recommendations, including those regarding handling of contaminated clothing. After spraying, wash hands and face before eating or drinking.

## Keep Components A and B Separate

				
Cross-contamination can result in cured material in fluid lines which could cause serious injury or damage equipment. To prevent cross-contamination:				
<ul style="list-style-type: none"> <li>• <b>Never</b> interchange component A and component B wetted parts.</li> <li>• Never use solvent on one side if it has been contaminated from the other side.</li> </ul>				

## Moisture Sensitivity of Isocyanates

Exposure to moisture (such as humidity) will cause ISO to partially cure, forming small, hard, abrasive crystal that become suspended in the fluid. Eventually a film will form on the surface and the ISO will begin to gel, increasing in viscosity.

<b>NOTICE</b>
Partially cured ISO will reduce performance and the life of all wetted parts.
<ul style="list-style-type: none"> <li>• Always use a sealed container with a desiccant dryer in the vent, or a nitrogen atmosphere. <b>Never</b> store ISO in an open container.</li> <li>• Keep the ISO pump wet cup or reservoir (if installed) filled with appropriate lubricant. The lubricant creates a barrier between the ISO and the atmosphere.</li> <li>• Use only moisture-proof hoses compatible with ISO.</li> <li>• Never use reclaimed solvents, which may contain moisture. Always keep solvent containers closed when not in use.</li> <li>• Always lubricate threaded parts with an appropriate lubricant when reassembling.</li> </ul>

**NOTE:** The amount of film formation and rate of crystallization varies depending on the blend of ISO, the humidity, and the temperature.

## Changing Materials

### **NOTICE**

Changing the material types used in your equipment requires special attention to avoid equipment damage and downtime.

- When changing materials, flush the equipment multiple times to ensure it is thoroughly clean.
- Always clean the fluid inlet strainers after flushing.
- Check with your material manufacturer for chemical compatibility.
- When changing between epoxies and urethanes or polyureas, disassemble and clean all fluid components and change hoses. Epoxies often have amines on the B (hardener) side. Polyureas often have amines on the B (resin) side.

# Component Identification

40cc pump shown

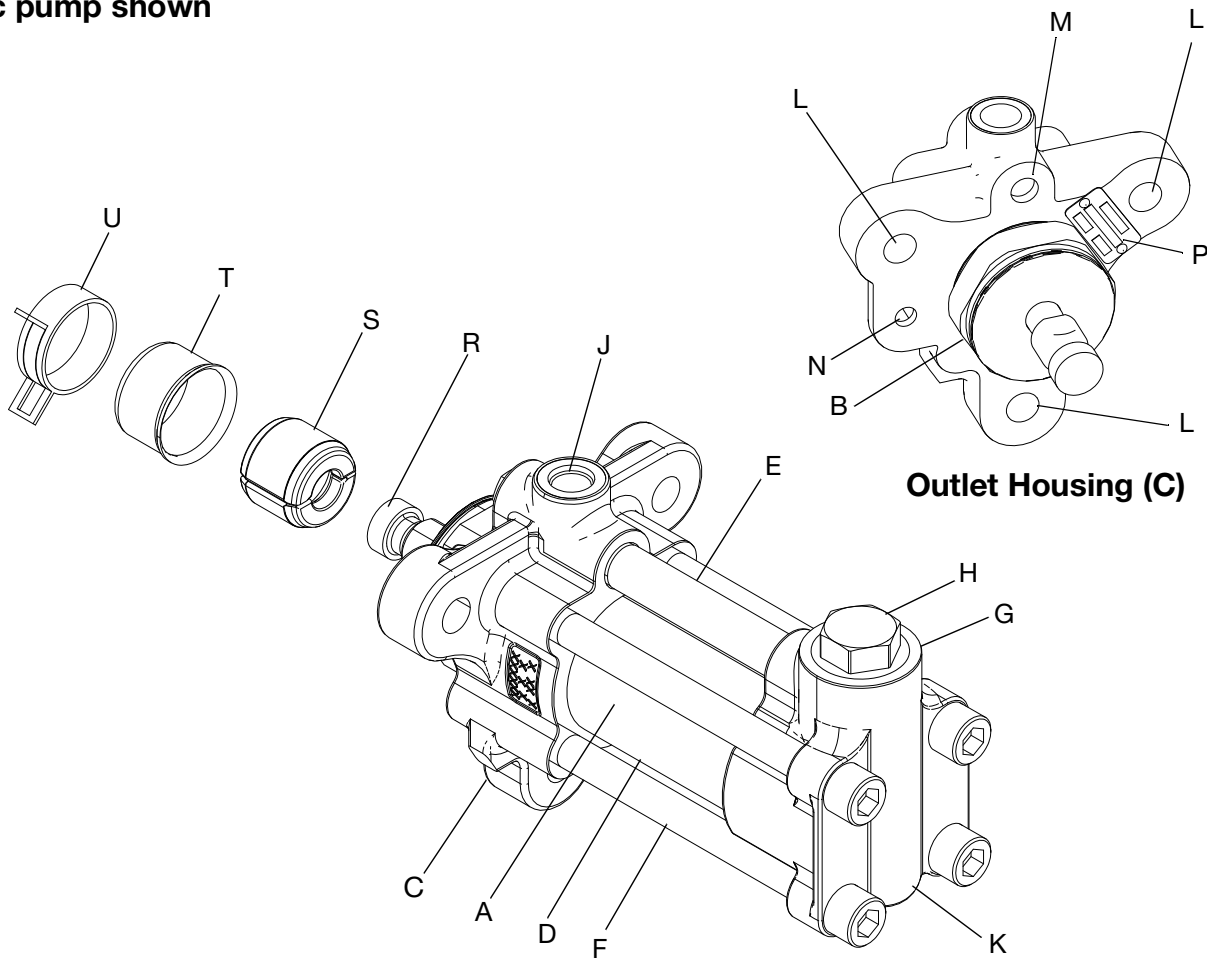

**FIG. 1: Component Identification**

**Key:**

- |   |   |   |                                       |
|---|---|---|---------------------------------------|
| A | Displacement Rod (inside main cylinder) | K | Fluid Inlet (bottom of inlet housing) |
| B | Throat Cartridge                        | L | Pump Mounting Holes                   |
| C | Outlet Housing                          | M | Pressure Transducer Port              |
| D | Main Cylinder                           | N | Linear Transducer Mounting Hole       |
| E | Crossover Tube                          | P | Identification Tag                    |
| F | Tie Bolt                                | R | Rod Adapter (not on all models)       |
| G | Inlet Housing                           | S | Pump Coupler                          |
| H | Inlet Cap                               | T | Coupler Cover                         |
| J | Fluid Outlet                            | U | Coupler Clamp                         |



# Operation

## Pressure Relief Procedure



Follow the Pressure Relief Procedure whenever you see this symbol.

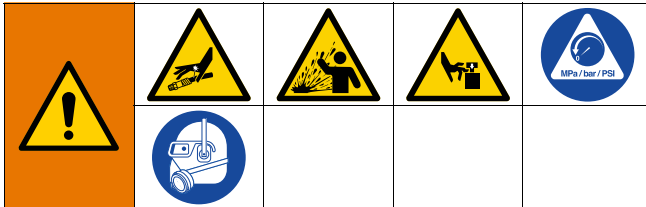

This equipment stays pressurized until pressure is manually relieved. To help prevent serious injury from pressurized fluid, such as skin injection, splashing fluid and moving parts, follow the Pressure Relief Procedure when you stop spraying and before cleaning, checking, or servicing the equipment.

1. Press the enable/disable key on the ADM  to disable the EFR/HFR, and verify it is inactive.
2. Relieve pressure and shut off the supply systems. See your appropriate supply system manual.
3. Turn the PRESSURE RELIEF/DISPENSE valves to PRESSURE RELIEF/CIRCULATION. Route the fluid to grounded waste containers or supply tanks. Ensure gauges read 0.
4. **For models with a dispense valve with a safety lock,** engage the dispense valve safety lock.

## Flushing



To avoid fire and explosion, always ground equipment and waste container. To avoid static sparking and injury from splashing, always flush at the lowest possible pressure.

Hot solvent may ignite. To avoid fire and explosion:

- Flush equipment only in a well-ventilated area
  - Ensure main power is off and the heater is cool before flushing
  - Do not turn on heater until fluid lines are clear of solvent
- 
- Flush before changing colors, before fluid can dry in the equipment, at the end of the day, before storing, and before repairing equipment.
  - Flush at the lowest pressure possible. Check connectors for leaks and tighten as necessary.
  - Flush with a fluid that is compatible with the fluid being dispensed and the equipment wetted parts.

# Maintenance

NOTE: If the quick lube system is installed on the Z-Pump elite series, use one of the following operation manuals for instructions. 313997, 3A1961 or 3A6165.

## Grease Cup Maintenance

**NOTE:** For pumps with grease fittings.

Frequency of greasing intervals is dependent on material being pumped. As a basic schedule, lubricate pump with grease after 250 gallons of material (five of fifty five gallon drums) has been passed through the pump.

If the grease has become hardened, remove the materials or grease, and shorten the intervals between greasing the pump.

If the grease remains clear and free of material, intervals between greasing the pump can be increased.

## To Grease the Pump

1. Remove the M5 socket head screw (D) to permit grease to circulate through the pump correctly.
2. Attach grease gun to the grease fitting (C). Pump new grease into the pump until fresh grease is observed from grease relief hole (E).
3. Replace and re-tighten the M5 socket head screw (D). See FIG. 2.

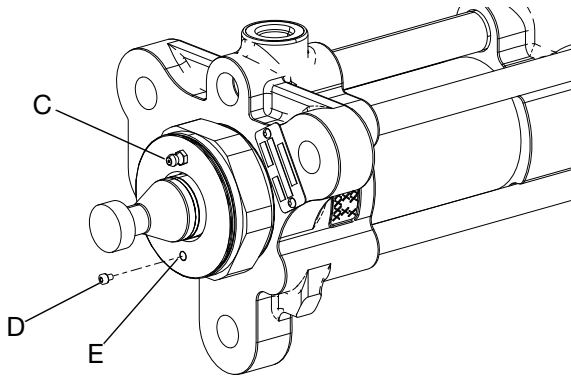
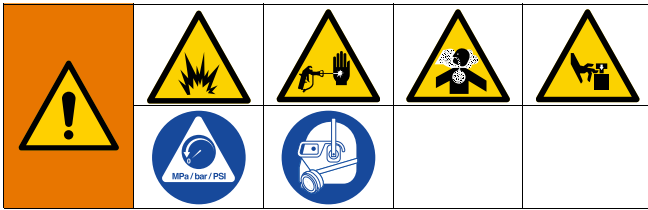

FIG. 2

# Repair



## Required Tools

- Large vise
- Set of adjustable wrenches
- O-ring pick
- 1/2 in. Allen (hex) bit socket
- 3/8 in. Allen (hex) wrench
- 1 1/4 in. wrench
- 1 1/8 in. crow foot wrench
- Rubber mallet
- Torque wrench
- 1 in. wrench
- 2 in., 2.25 in. and 3 in. sockets
- Anti-seize lubricant
- Removable strength thread locker
- Grease (As compatible with the material being dispensed)

## Inlet Housing Disassembly

### L020S8 Model

1. Relieve pressure and flush system. Follow **Pressure Relief Procedure and Flushing**, page 9.
2. Remove inlet hose and drain inlet housing (106).
3. Remove inlet valve cap (113) from inlet housing (106), and remove o-ring (108). See FIG. 3.

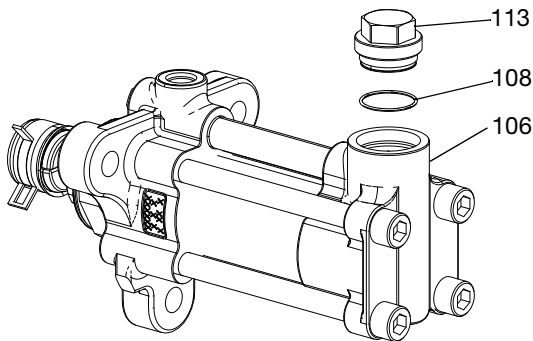

FIG. 3

4. Remove upper check assembly (AA), including the spring retainer (137), check housing (138), conical spring (139), ball housing retainer (140), ball (141), carbide seat (142), O-ring (143), retainer (144), and O-ring (108).
5. Remove lower check (BB), including the spring retainer (137), check housing (138), conical spring (139), ball housing retainer (140), ball (141), carbide seat (142), O-ring (143), retainer (144), and O-ring (108). See FIG. 4.

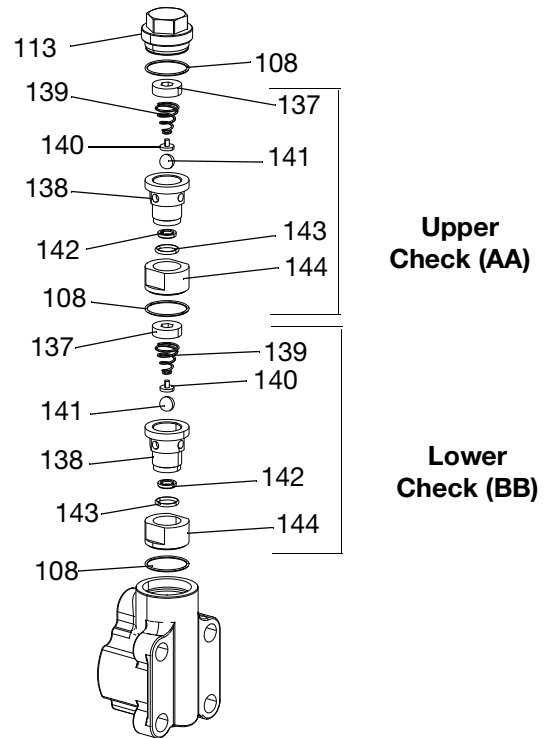

FIG. 4

6. Clean all parts in a compatible solvent. Lay the parts in order for easier reassembly. Inspect each ball and seat for nicks or scratches then replace as required.
7. It is recommended to replace the o-rings (108, 143) after cleaning.

### L040S8, L080S8, L100S8, L120S8 and L160S8 Models

1. Relieve pressure and flush system. Follow **Pressure Relief Procedure and Flushing**, page 9.

2. Remove inlet hose and drain inlet housing (106).
3. Remove inlet valve cap (113) from inlet housing (106), and remove o-ring (108). See FIG. 5.

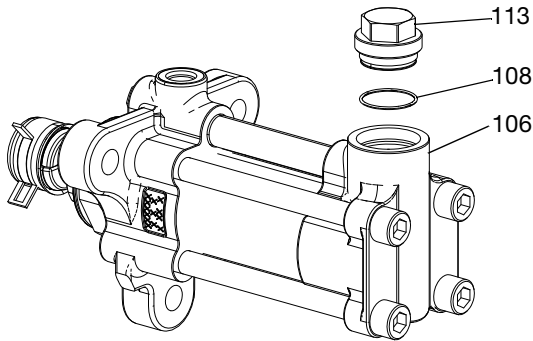

**FIG. 5**

4. Remove upper check (CC) ball cage (112), check ball spring (111), ball (110), O-ring (108) and carbide seat (109).
5. Press lower ball (110) off seat (109) from fluid inlet and drain the inlet housing (106).
6. Remove lower check (DD) o-ring (108), ball cage (112), check ball spring (111), ball (110), carbide seat (109), and o-ring (108). See FIG. 6.

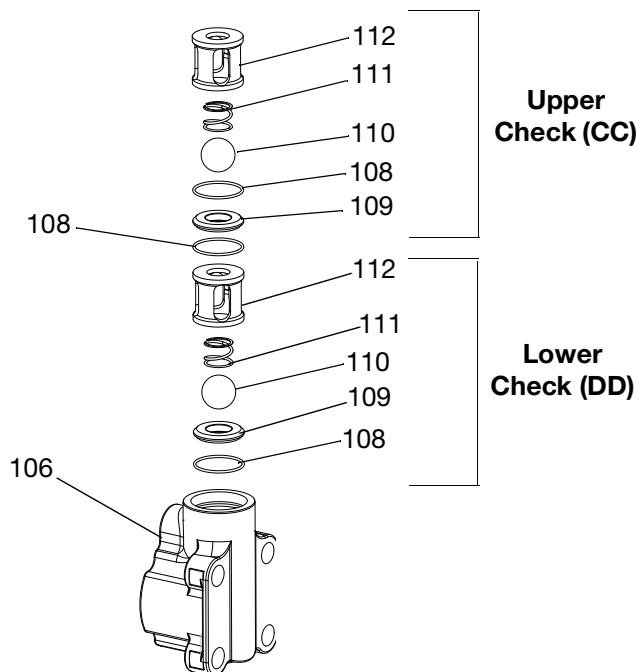

**FIG. 6**

7. Clean all parts in a compatible solvent. Lay the parts in order for easier reassembly. Inspect each ball and seat for nicks or scratches then replace as required

## Inlet Housing Assembly

### L020S8 Model

1. Assemble upper check assembly (AA). Apply anti-seize lubricant to the check housing (138), spring retainer (137) and check valve retainer (144).
2. Install the O-ring (143) and then the carbide seat (142) into the check valve retainer(144). The check housing (138) then threads into the check valve retainer and is torqued to 50 ft-lbs (67.5 N•m).

**NOTE:** The sharp corner of the outside diameter of the carbide seat (142) must face towards the check housing (138) and the ball (141). See FIG. 7.

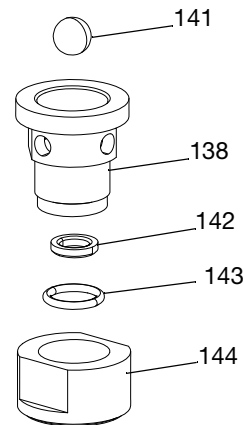

**FIG. 7**

3. Install the ball (141), ball housing retainer (140) and conical spring (139) into the check housing (138).
4. Install the spring retainer (137) cup side down into the check housing (138) to trap the spring (139) until the spring retainer bottoms out into the check housing. Torque spring retainer to 30 ft-lbs (41 N•m.) See FIG. 8, page 13.

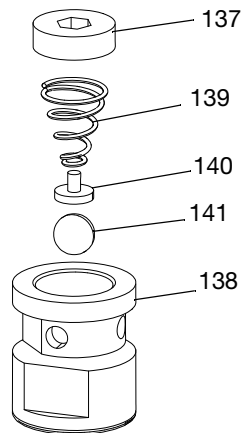

**FIG. 8**

5. Assemble lower check assembly (BB) using the steps 1 through 4 above.
6. Install the o-ring (108) into the inlet housing (106).
7. Install lower check (BB) into the housing (106) in the orientation shown.
8. Install the o-ring (108) into the inlet housing (106).
9. Install upper check assembly (AA) into the inlet housing (106) in the orientation shown.
10. Install o-ring (108) on valve inlet cap (113) and apply anti-seize lubricant to valve inlet cap threads. Torque inlet cap to 70 ft-lbs. (95 N•m). See FIG. 9. .

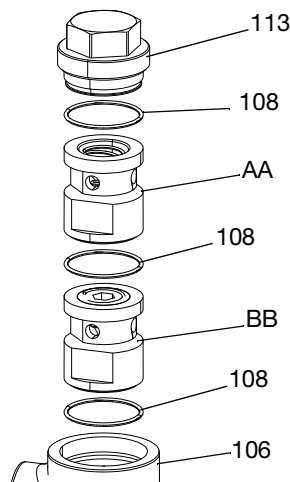
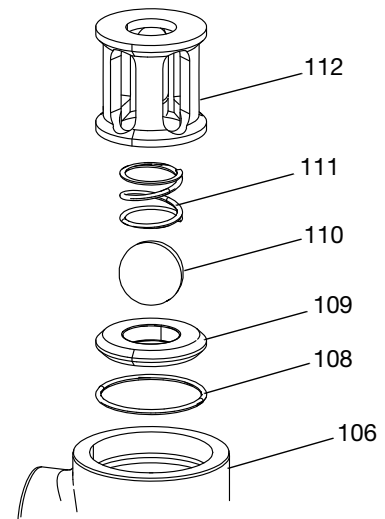

**FIG. 9**

**L040S8, L080S8, L100S8, L120S8 and L160S8 Models**

1. Apply anti-seize lubricant to the threads of inlet valve cap (113) and install O-ring (108) into the groove.
2. Assemble lower check assembly (DD). Install O-ring (108) into inlet housing (106) followed by the carbide seat (109).
3. Place the ball (110) onto the carbide seat (109) followed by the ball check spring (111) and the ball cage housing (112).

**NOTE:** Confirm the orientation of the ball cage prior to installing. The end with the larger opening must face the spring. See FIG. 10.



**FIG. 10**

4. Assemble upper check assembly (CC). Repeat step 2 above after placing an O-ring (108) on top of the lower check assembly (DD).
5. Install the valve inlet cap(113) compressing both check assemblies together into the inlet housing. Torque the valve inlet cap to 70 ft-lbs. (95 N•m).

## Pump Disassembly

1. Relieve pressure and flush system. Follow **Pressure Relief Procedure** and **Flushing**, page 9.
2. Remove inlet and outlet hoses, drain inlet housing (106), and outlet housing (107). If quick lube system is installed, detach hoses from outlet housing (107).
3. Using a bench vice, horizontally clamp the pump on outlet housing (107). Use a 1/2 in. hex bit socket to loosen all four tie bolts (105) from inlet housing (106).
4. For 20cc - 40cc pumps only: Use wrench to remove rod adapter (121). See FIG. 11.

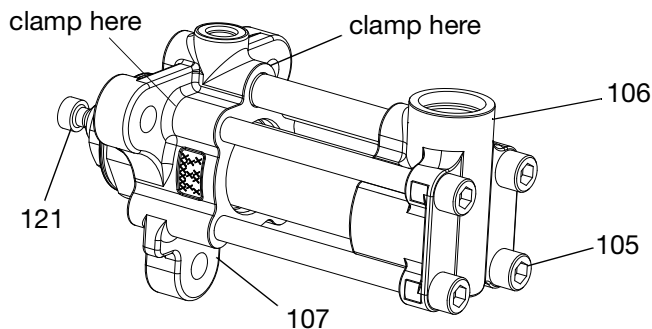

FIG. 11

5. Remove pump assembly from vise and lay on a flat surface with towels or in catch pan.
6. Completely remove the tie bolts (105). See FIG. 12.

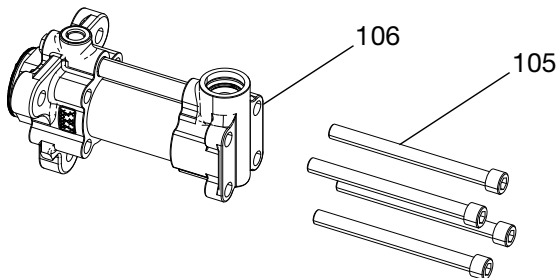

FIG. 12

7. Remove inlet housing (106) from pump cylinder (103). Remove pump crossover tube (104) and o-rings (102). See FIG. 13.

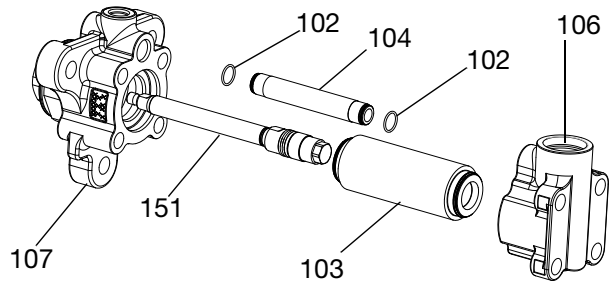

FIG. 13

8. Pull pump cylinder (103) and displacement rod (151) away from outlet housing (107).

**NOTICE**

Be careful not to scratch the displacement rod (151); place it on a smooth working surface. Damage to the displacement rod will shorten pump life.

9. Remove displacement rod (151) from pump cylinder (103). See FIG. 14.

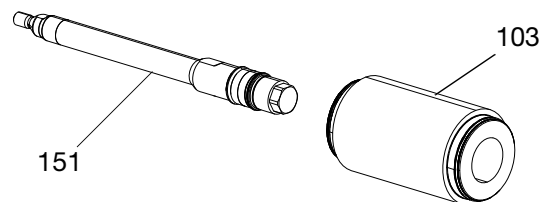

FIG. 14

10. Remove two o-rings (101) from pump cylinder (103). See FIG. 15.

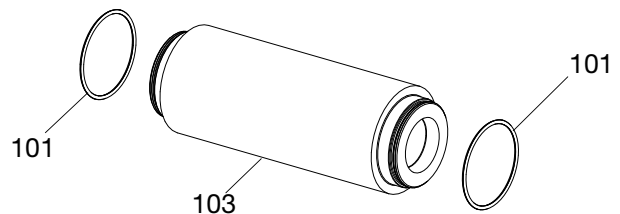
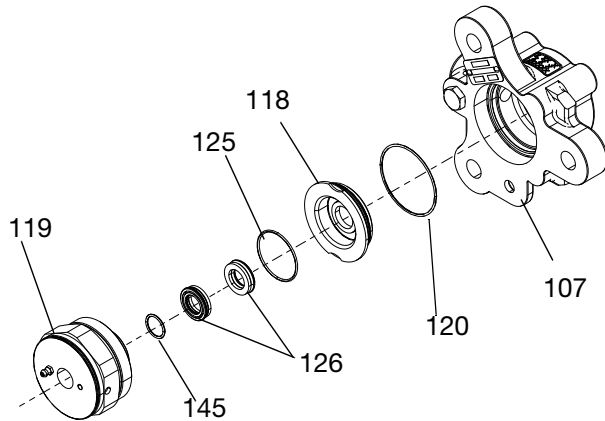

FIG. 15

11. Place outlet housing (107) in vise so throat cartridge (119) is facing up.

12. Remove throat cartridge (119).
13. Use o-ring pick and remove o-ring (145) from inside throat cartridge (119), two throat seals (126) out of the throat cartridge, and O-ring (125) from the of the throat cartridge. see FIG. 16.
14. Remove throat retainer (118) and throat retainer o-ring (120). See FIG. 16.



**FIG. 16**

15. To disassemble pump rod (151), clamp flats on seal end of pump rod bottom(124) in vise. Remove piston retainer (114), piston bearing retainer (116), and two piston seals (117). See FIG. 17 and FIG. 18.

**For 20cc-40cc Pumps**

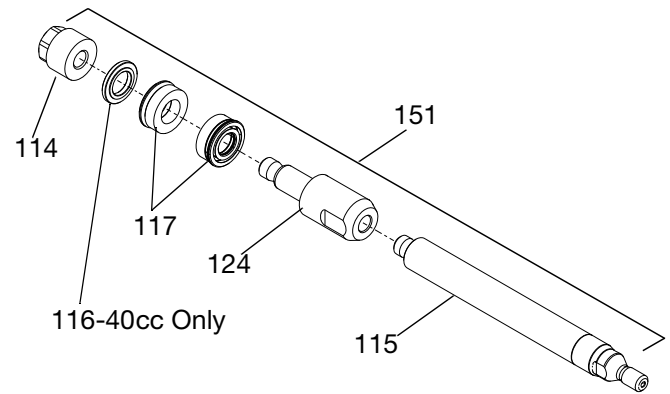

r\_257891\_3a0019\_11h

**FIG. 17**

**For 80cc-160cc Pumps**

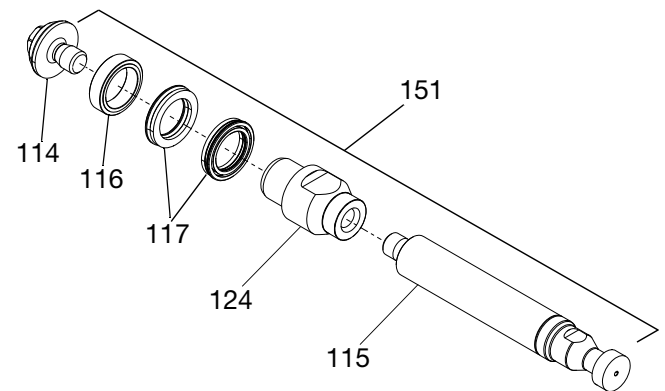

r\_257891\_3a0019\_26h

**FIG. 18**

16. If the pump rod bottom (124) shows damage or wear on the surface below the piston seals (117) it should be replaced to prevent damage to new seals.
17. Thoroughly clean all metal parts in a compatible solvent.

# Pump Assembly

**NOTICE**  
To prevent cross-contamination and damage of the equipment's wetted parts, never interchange component A (isocyanate) and component B (resin) parts.

1. If the pump rod bottom (124) was removed clean any residual sealant from the threads of the piston shaft (115). Apply one stripe of removable strength thread locker to the male threads on (115) pump sizes 20-120cc pumps or the male threads on (124) for 160cc pumps. When fully threaded together torque the shafts to the value shown in the table below.

Pump Size	Torque
20	25 ft-lbs (34 Nm)
40	50 ft-lbs (67.5 Nm)
80-160	55 ft-lbs (74.5 Nm)

2. Apply grease to seal and bearing surface of displacement rod (124), piston seals (117) and piston bearing retainer (116) 40cc -160cc only.
3. Install piston seals (117) onto the pump rod bottom (124). Confirm the first piston seal faces the displacement rod (115) and the second piston seal faces the piston retainer (114) for 20cc size and the bearing retainer (116, 40cc-160cc size. only). See FIG. 19 and FIG. 20

**NOTICE**  
Specification sheets and Graco testing indicate that anaerobic sealant requires three days to fully cure. Failure to allow three days for full cure may result in damage to the equipment from parts coming loose during operation. If faster cure time is required, warm components to 104° F (40° C) for 6 hours.

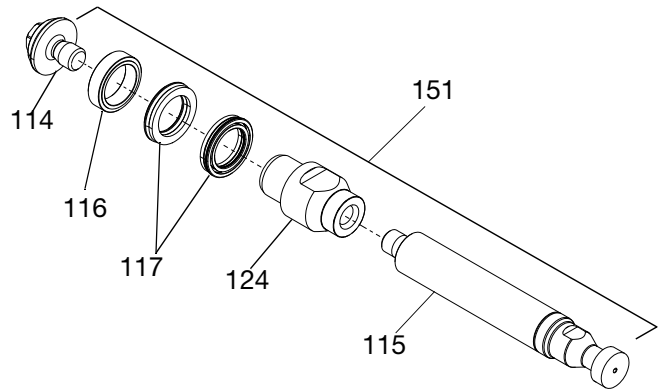

r\_257891\_3a0019\_26h

**FIG. 20 80cc through 160cc pumps**

**NOTICE**  
To prevent displacement rod damage, do not clamp directly onto displacement rod surface.

4. Clamp flats on seal end of pump rod bottom (124) in vise. See Torque Specification table for piston retainer (114) torque according to pump size.

## Piston Retainer Torque Specifications

Pump Size	Torque
20cc	30 ft-lbs (40.6 N•m)
40cc	50 ft-lbs (67.5 N•m)
80cc	80 ft-lbs (108 N•m)
100cc	160 ft-lbs (216 N•m)
120cc	160 ft-lbs (216 N•m)
160cc	160 ft-lbs (216 N•m)

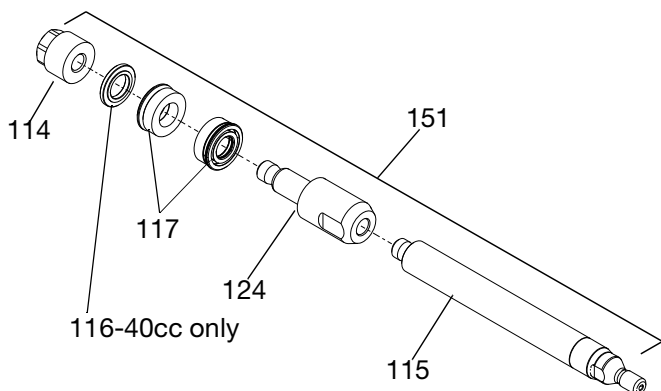

r\_257891\_3a0019\_11h

**FIG. 19 20cc and 40cc pumps**



- Apply grease to the o-ring (145) and the two throat seals (126). Install the o-ring (145) into the upper most groove of the throat cartridge (119). slide O-ring (125) over the boss end of the throat cartridge (119). Place first throat seal into the throat cartridge (119) and ensure the first throat seal spring faces towards the bottom of the throat cartridge. Using a suitable size socket or dowel, press the throat seal to the bottom of the throat cartridge
- Place the second throat seal (126) into the throat cartridge (119) ensuring the spring side faces up toward the throat retainer (118). Using a suitable size socket or dowel, press the second throat seal into the throat cartridge until it contacts the first throat seal. See FIG. 21.

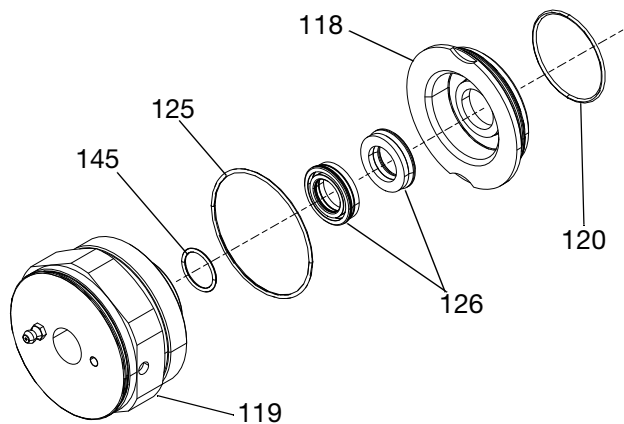

**FIG. 21**

- With the outlet housing (107) mounted securely in a vice, Install the throat retainer O-ring (120) onto the throat retainer (118). Place the retainer into the outlet housing (107).
- Apply anti-seize to the threads on the throat retainer (119) and thread it into the outlet housing (107). When fully threaded together torque the throat retainer to 200 ft-lbs. (271 N•m). See FIG. 22.

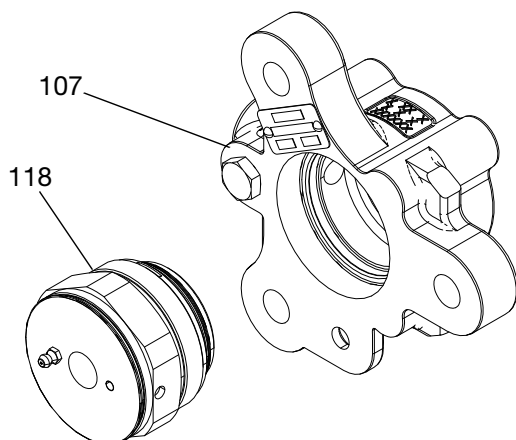

**FIG. 22**

- Install cylinder o-rings (101) on pump cylinder (103) and crossover tube o-rings (102) on crossover pump tube (104). Lubricate o-rings with grease. See FIG. 23.

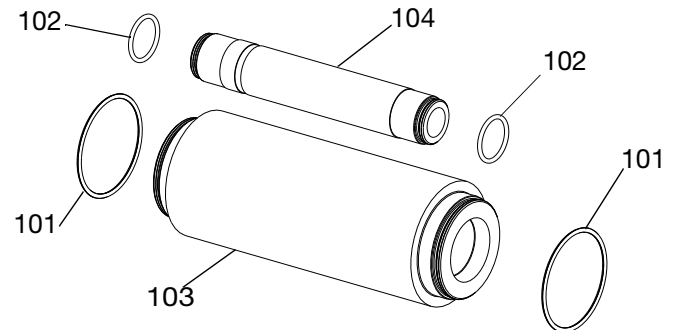

**FIG. 23**

- Install pump cylinder (103) and pump crossover tube (104) in outlet housing (107) with a rubber mallet. See FIG. 24..

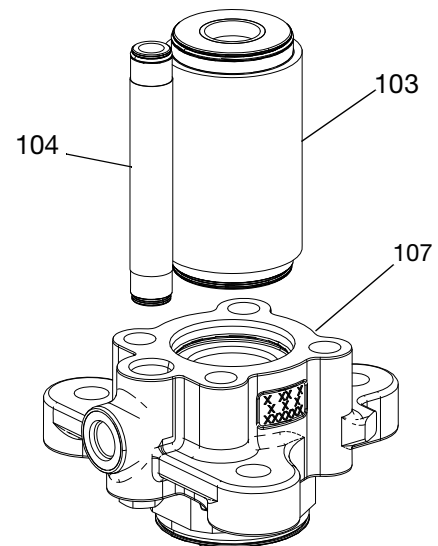

3A8563\_repair 8

**FIG. 24**

- Lubricate piston seals (117), and piston bearing retainer (116) with grease.

**NOTE:** For 160cc pumps, place the cylinder installation tool (150) over the end of the pump cylinder (103) to help guide the displacement rod (151) during installation. See FIG. 25 page 18.

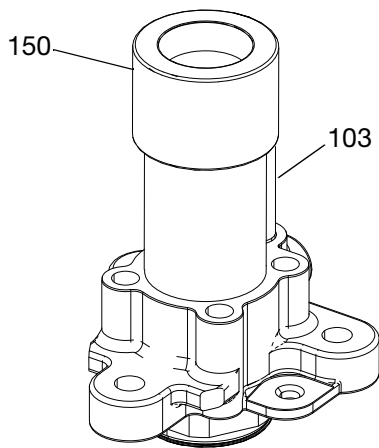

**FIG. 25**

12. Install displacement rod (151) in pump cylinder (103) and into throat cartridge (118). Gently tap displacement rod with a rubber mallet until the hex surface of the piston retainer (114) is flush or below the surface of the pump cylinder (103). See FIG. 26.

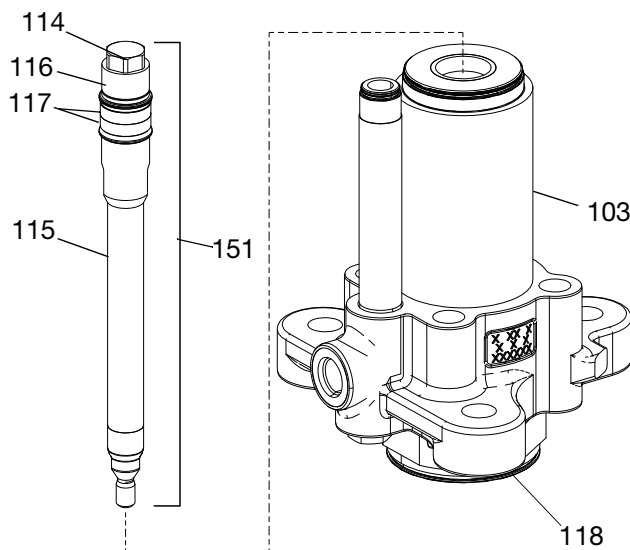

3A8563\_repair 9  
**FIG. 26**

13. Gently place inlet housing (106) on pump cylinder (103) and pump crossover tube (104). Ensure inlet housing bores are aligned with pump cylinder and pump crossover tube. Install with a rubber mallet.

**NOTICE**

To prevent damage to o-rings, ensure inlet housing is evenly seated on main cylinder before installing tie bolts (105).

14. Lubricate four tie bolts (105) threads and install.

15. Torque tie bolts (105) in a star pattern (see FIG. 27) to 10 ft-lbs (13.5 N•m). Then torque again to 50 ft-lbs (67.5 N•m). Torque a final time to 200 ft-lbs (271 N•m)

16. After torquing the four tie bolts (105) ensure the inlet housing (106) is evenly seated onto the pump cylinder (103) and pump crossover tube (104).

17. For 20cc-40cc pumps only: Clean rod adapter (121) threads with a wire brush and apply removable strength thread locker to displacement rod (115) threads. Install rod adapter (121) on displacement rod (115). Torque Rod adapter and displacement rod together to 45 ft-lbs (60.75 N•m). See FIG. 27.

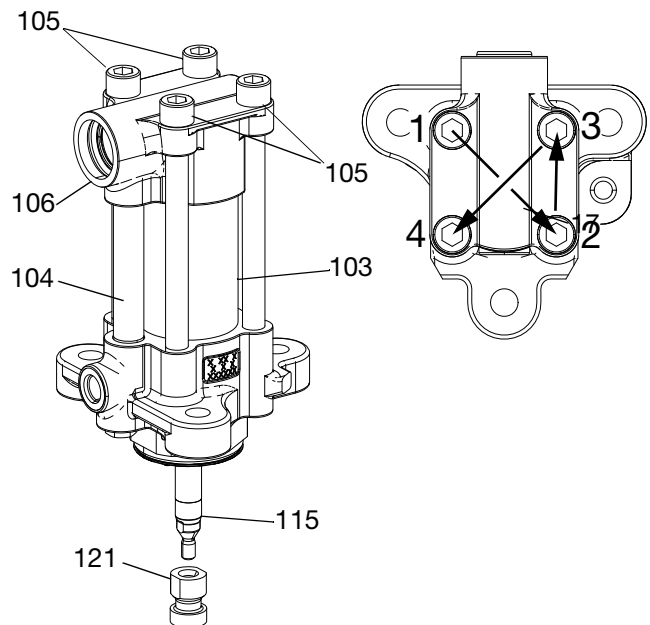

**FIG. 27**

r\_257891\_3a0019\_19h

# Parts

## Table 1 Complete Pump

### 20cc Pump, Model L020S8

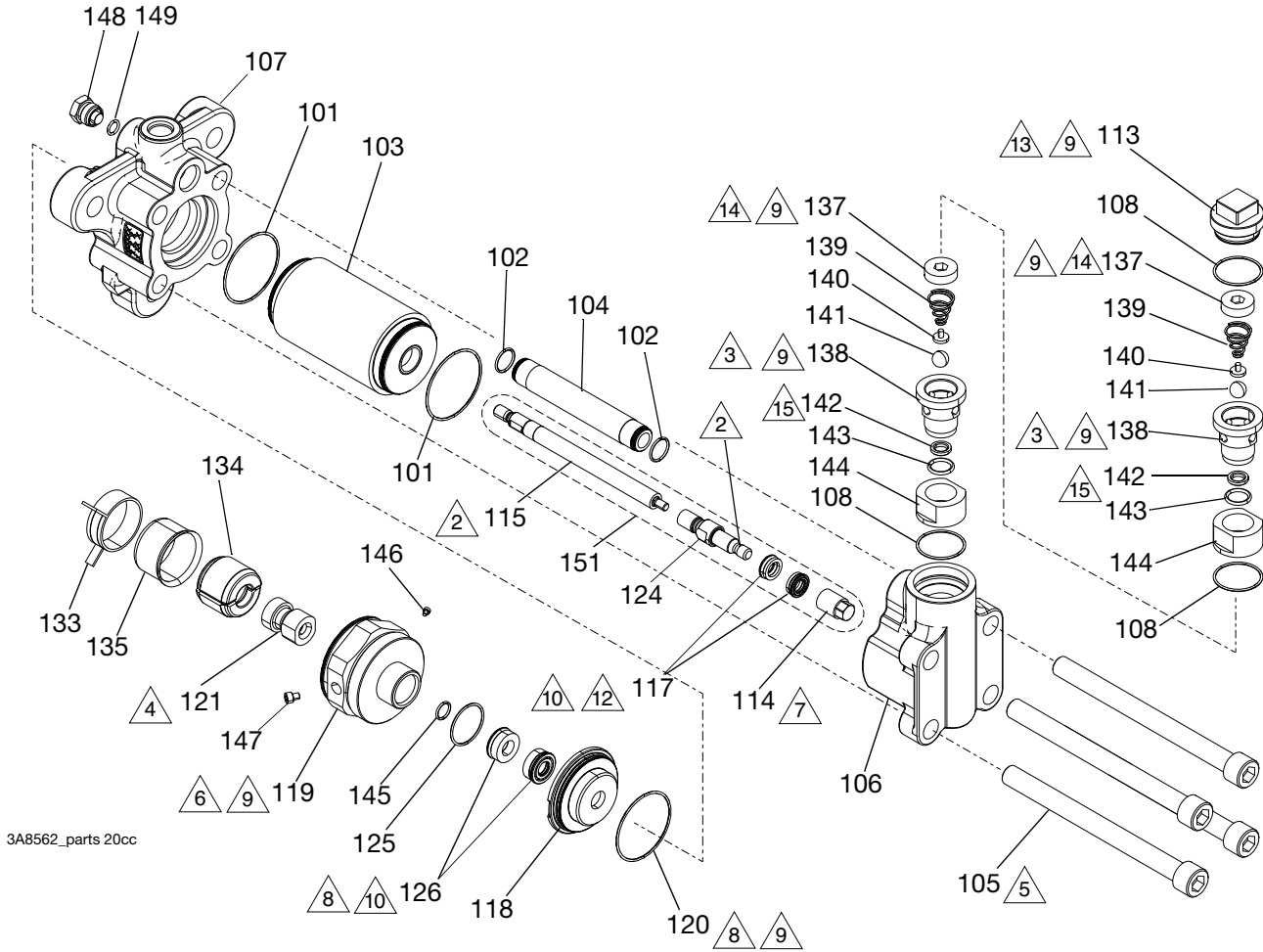

**FIG. 28**

1. Lubricate seals, o-rings, lead-in's and moving parts with grease.

△ Apply one stripe of removable strength anaerobic sealant on threads.

**NOTICE**

Specification sheets and Graco testing indicate that anaerobic sealant requires three days to fully cure. Failure to allow three days for full cure may result in damage to the equipment from parts coming loose during operation. If faster cure time is required, warm components to 104° F (40° C) for 6 hours

△ Torque to 50-ft-lbs (67.5 N•m).

△ Assemble and torque after displacement rod (115) is assembled through throat retainer (119). Torque to 45 ft-lbs (61.01 N•m)

△ Torque tie bolts (105) in star pattern ( FIG. 27 page 18) to 10 ft-lbs (13.5 N•m). Then torque again to 50 ft-lbs (67.5 N•m). Finally torque to 200 ft-lbs (271 N•m).

△ Torque to 200 ft-lbs. (271 N•m).

△ See **Piston Retainer Torque Specifications** table on page 16 for torque specification.

△ Must be pressed straight into housing.

△ Apply anti-seize lubricant to threads.

△ Mount such that the non-spring side of the two seals touch.

△ Fully assemble piston seals(117) and piston bearing retainer (116) onto pump rod bottom (124) before tightening piston retainer (114).

△ Torque to 70 ft-lbs. (95 N•m).

△ Torque to 30 ft-lbs. (41 N•m).

△ Sharp corner of outside diameter faces up towards the check housing (138).

### 40cc Pump, L040S8

3A8562\_parts 40cc

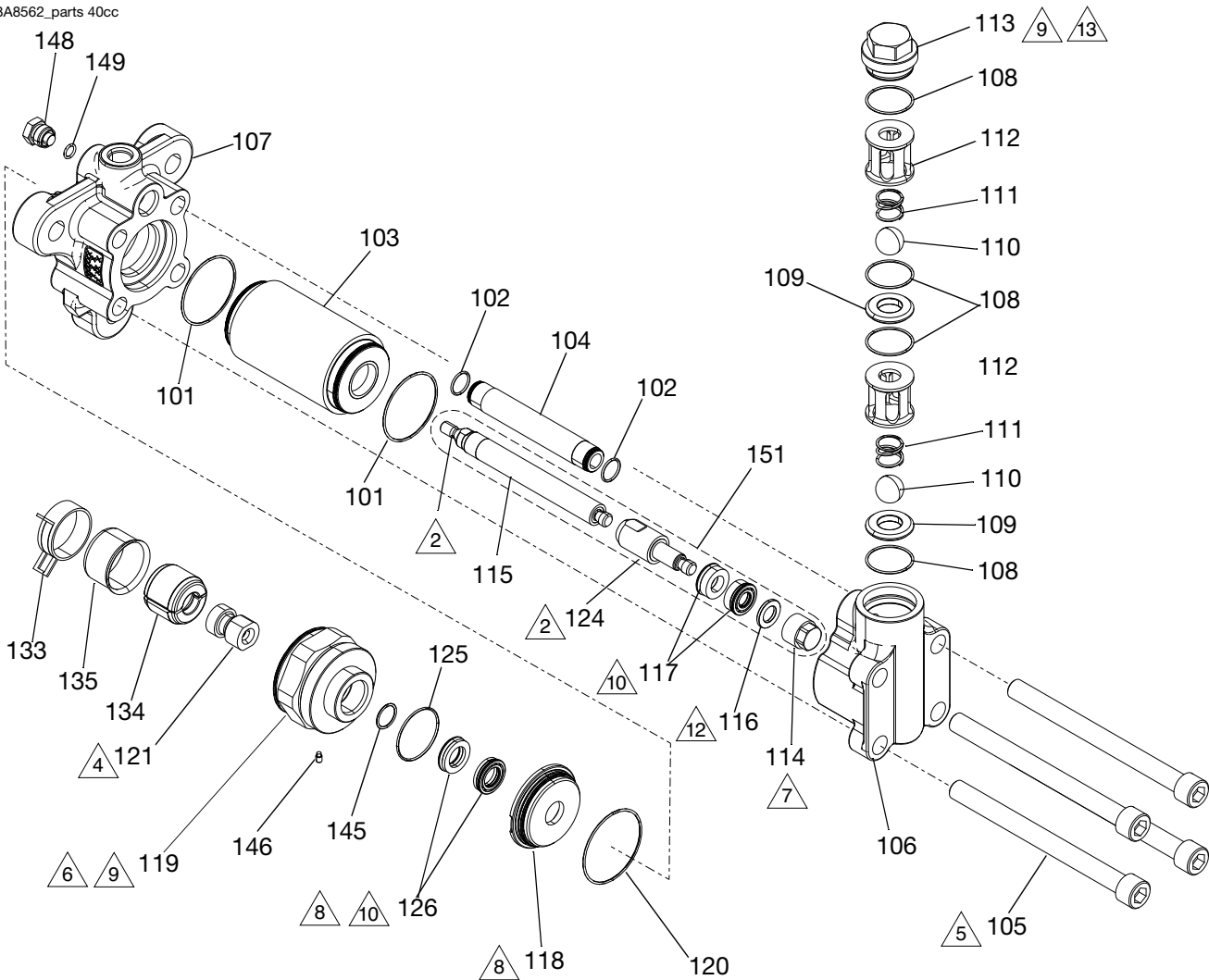

Fig. 29

1. Lubricate seals, o-rings, lead-in's and moving parts with grease.

△ Apply one stripe of removable strength anaerobic sealant on threads.

**NOTICE**

Specification sheets and Graco testing indicate that anaerobic sealant requires three days to fully cure. Failure to allow three days for full cure may result in damage to the equipment from parts coming loose during operation. If faster cure time is required, warm components to 104° F (40° C) for 6 hours.

△ Torque to 50-ft-lbs (67.5 N•m).

△ Assemble and torque after displacement rod (115) is assembled through throat retainer (119). Torque to 45 ft-lbs (61.01 N•m)

△ Torque tie bolts (105) in star pattern ( Fig. 27 page 18) to 10 ft-lbs (13.5 N•m). Then torque again to 50 ft-lbs (67.5 N•m). Finally torque to 200 ft-lbs (271 N•m).

△ Torque to 200 ft-lbs. (271 N•m).

△ See **Piston Retainer Torque Specifications** table on page 16 for torque specification.

△ Must be pressed straight into housing.

△ Apply anti-seize lubricant to threads.

△ Mount such that the non-spring side of the two seals touch.

△ Fully assemble piston seals(117) and piston bearing retainer (116) onto pump rod bottom (124) before tightening piston retainer (114)..

△ Torque to 70 ft-lbs. (95 N•m).

**80cc Pump, Model L080S8**  
**100cc Pump, Model L100S8**  
**120cc Pump, Model L120S8**  
**160cc Pump, Model L160S8**

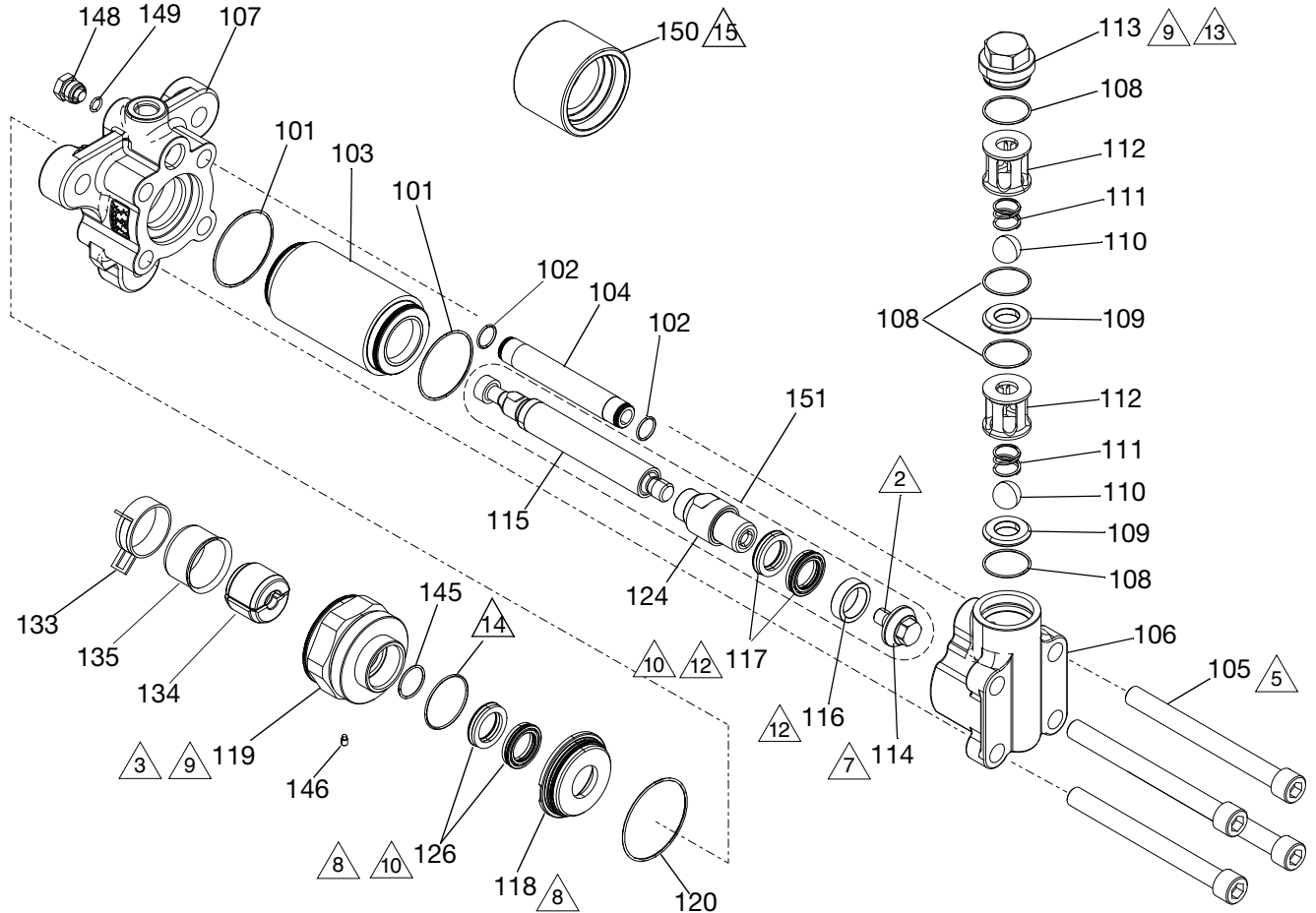

**FIG. 30**

1. Lubricate seals, o-rings, lead-in's and moving parts with grease.

△ Apply one stripe of removable strength anaerobic sealant on threads.

**NOTICE**

Specification sheets and Graco testing indicate that anaerobic sealant requires three days to fully cure. Failure to allow three days for full cure may result in damage to the equipment from parts coming loose during operation. If faster cure time is required, warm components to 104° F (40° C) for 6 hours.

△ Torque to 50-ft-lbs (67.5 N•m).

△ Torque tie bolts (105) in star pattern ( Fig. 27 page 18) to 10 ft-lbs (13.5 N•m). Then torque again to 50 ft-lbs (67.5 N•m). Finally torque to 200 ft-lbs (271 N•m)

△ Torque to 200 ft-lbs. (271 N•m).

△ See **Piston Retainer Torque Specifications** table on page 16 for torque specification.

△ Must be pressed straight into housing.

△ Apply anti-seize lubricant to threads.

△ Mount such that the non-spring side of the two seals touch.

△ Fully assemble u-cups (17) and bearing (16) onto displacement rod (15) before tightening piston retainer (14).

△ Torque to 70 ft-lbs. (95 N•m).

△ O-ring 125 is used for the 80cc and 160cc pumps and O-ring 101 is used for 100cc and 120cc pumps.

△ Used on 160cc pump only.

**20cc Pump, Model L020S8, 40cc Pump, Model L040S8, 80cc Pump, Model L080S8, 100cc Pump, Model L100S8, 120cc Pump, Model L120S8, 160cc Pump, Model L160S8, Parts List**

				Pump Size					
				20cc	40cc	80cc	100cc	120cc	160cc
				Fig. 28	Fig. 29	Fig. 30			
Ref.	Part	Part Kit	Description	Quantity					
101✓✿◆*	106259	See Table 2	PACKING, O-ring	2	2	2	3	3	-
	108823	See Table 3 and Table 4		-	-	-	-	-	2
102✓✿◆*	111116	----	PACKING, O-ring	2	2	2	2	2	2
103✿	WKO*	----	CYLINDER, pump	1	1	1	1	1	1
104	15V458	24E556	TUBE, crossover, pump	1	1	1	1	1	-
		See Table 2		-	-	-	-	-	1
105	122704	258790	BOLT, tie	4	4	4	4	4	4
106	15Y165	See Table 2	HOUSING, inlet	1	1	1	1	1	-
	WKO*			-	-	-	-	-	1
107	15X946	See Table 2	HOUSING, outlet	1	1	1	1	1	-
	WKO*			-	-	-	-	-	1
108◆✿◆+	107098	See Table 6	PACKING, O-ring	3	4	4	4	4	4
109•	196832	See Table 5	SEAT, carbide	2	-	-	-	-	-
	15J038			-	2	2	2	2	2
110•	17R406	See Table 5	BALL, carbide	-	2	2	2	2	2
111	122756		SPRING, ball check	-	2	2	2	2	2
112	WKO*	See Table 5	HOUSING, ball cage	-	2	2	2	2	2
113	WKO*		CAP, inlet valve	1	1	1	1	1	1
114***	WKO*	See Table 4	RETAINER, piston	1	1	1	1	1	1
115*✓	WKO*	See Table 2	ROD, displacement	1	1	1	1	1	1
116◆*	WKO*	See Table 3 and Table 4	BEARING, piston, retainer	-	1	1	1	1	1
117◆*	WKO*		SEAL, piston	2	2	2	2	2	2
118★	WKO*	See Table 2	RETAINER, throat	1	1	1	1	1	1
119✿	WKO*		CARTRIDGE, throat	1	1	1	1	1	1
120★*◆	117286	See Table 2 and Table 3	PACKING, O-ring	1	1	1	1	1	1
121*‡	WKO*	See Table 2	ADAPTER, rod	1	1	-	-	-	-
124*	WKO*	See Table 4	ROD, pump, bottom,	1	1	1	1	1	1
125✿◆*★	WKO*	See Table 2, Table 3 and Table 4	PACKING, O-ring	1	1	1	-	-	1
126◆*	WKO*	See Table 3 and Table 4	SEAL, throat	2	2	2	2	2	2
128	WKO*	See Table 2	PLATE, identification	1	1	1	1	1	1
129	WKO*		SCREW, drive	2	2	2	2	2	2
133	124078	----	CLAMP, spring	1	1	1	1	1	1
134	198031	----	COUPLER, pump	1	1	-	1	1	1
	15G923	----		-	-	1	-	-	-
135	197340	----	COVER, coupler	1	1	1	1	1	1

Ref.	Part	Part Kit	Description	Pump Size					
				20cc	40cc	80cc	100cc	120cc	160cc
				FIG. 28	FIG. 29	FIG. 30			
				Quantity					
137•	WKO*	See <b>Table 5</b>	RETAINER, spring pump	2	-	-	-	-	-
138•	WKO*		HOUSING, check valve, glass beads	2	-	-	-	-	-
139❖•	WKO*		SPRING, conical, 1x.85x.281, SST	2	-	-	-	-	-
140•	WKO*		RETAINER, housing, ball	2	-	-	-	-	-
141❖•	WKO*		BALL, .500, silicon-nitride, blk	2	-	-	-	-	-
142❖•	WKO*		SEAT, sharp, glass beads	2	-	-	-	-	-
143❖•◆	WKO*		PACKING, O-ring	2	-	-	-	-	-
144•	WKO*		RETAINER, check valve	2	-	-	-	-	-
145✖◆★	WKO*	----	PACKING, O-ring	1	-	-	-	-	-
146✖	WKO*	----	SCREW, sealing, SCHS, M3 x 4mm	1	1	1	1	1	1
147✖	WKO*	----	SCREW, sealing, SCHS, M5 x 6mm	1	-	-	-	-	-
148	198241	----	PLUG, port, pressure	1	1	1	1	1	1
149◆	121399	See <b>Table 3</b>	PACKING, O-ring	1	1	1	1	1	1
150❖◆*	18C159	See <b>Table 2, Table 3 and Table 4</b>	TOOL, installation, cylinder	-	-	-	-	-	1
151*	WKO*	See <b>Table 4</b>	ROD, displacement (Including Ref. No's. 114,115, 116, 117, and 124)	-	-	-	-	-	-

‡ See Adapter Rod Kit **Table 2**, Page 24.

✓ See Cylinder O-ring Kits, in **Table 2, Various Kits**, Page 24 for kit number.

❖ See Cylinder Kits, in **Table 2, Various Kits**, Page 24, for kit number.

★ See Throat Retainer Kits, in **Table 2, Various Kits**, Page 24 for kit number.

✖ See Throat Cartridge Kits, in **Table 2, Various Kits**, Page 24 for kit number.

\*\* See Piston Retainer Kits, in **Table 2, Various Kits**, Page 24 for kit number.

◆ See Seal Kits, in **Table 3 Seal Kits** on page 25, for kit number.

\* See Displacement Rod Kits, in **Table 4 Displacement Rod Kits** on page 28, for kit number.

❖ Included in check valve kits for 40-160cc. See **Table 5, Check Valve Kits**. Page 31.

• Included in check valve kits for 20cc. See **Table 5, Check Valve Kits**. Page 31.

‡ Included in **O-Ring Inlet Kit, All Pump Sizes**, See **Table 6**, Page 33.

\* (WKO) With Kits Only. Part is included in kit if quantity is shown. Part is only available as a member of a kit, therefore part number is not shown

**Table 2**

✓,✿,★,✕, \*\* (Reference symbols on main parts list for Various Kits)

**Various Kits**

Description	Pump Size	20cc	40cc	80cc	100cc	120cc	160cc	Includes Reference No's.
	Pump Model No.	L020S8	L040S8	L080S8	L100S8	L0120S8	L160S8	
	<b>Kit No's.</b>							
Adapter Rod	26D178‡		-					121
✓Cylinder O-ring Kits	258773						25R206	101,102
✿Cylinder Kits	26B811	26B818	26B824	26B831	26B837	26B843		101,102,103
★Throat Retainer Kits	26B813	26B819	26B826	26B832	26B838	26B844		118,120,125,145
✕Throat Cartridge Kits	26B814	26B820	26B827	26B833	26B839	26B845		119, 125, 145, 146,147
Inlet Housing Kits	258792						25R211	104,106
Outlet Housing Kits	258791						25R212	107
Displacement Rod Kits (Without Seals)	26D179	26D180	26D181	26D182	26D183	26D184		115



### Table 3

◆ (Reference symbol on main parts list for Seal Kits)

### Seal Kits

Seal Kit 26B816, for 20cc Pump Model L020S8

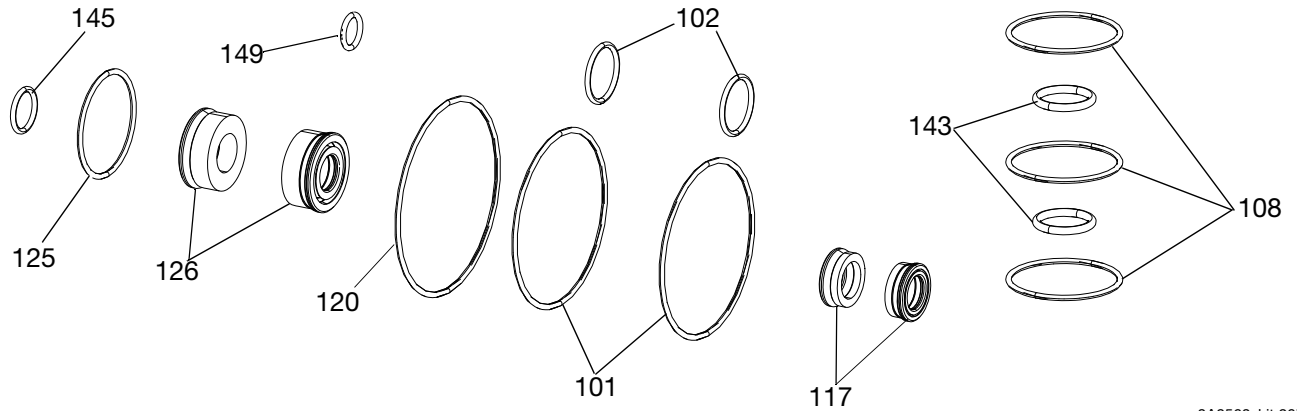
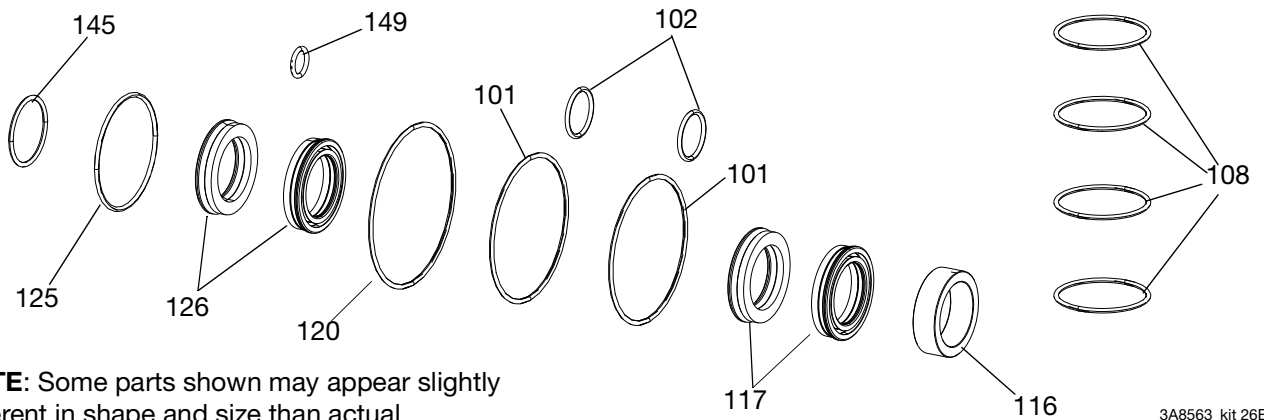

FIG. 31

3A8563 Kit 26B816

Seal Kit 26B822, for 40cc Pump Model L040S8

Seal Kit 26B829, for 80cc Pump Model L080S8



**NOTE:** Some parts shown may appear slightly different in shape and size than actual.

FIG. 32

3A8563\_kit 26B829

**Seal Kit 26B835, for 100cc Pump Model L0100S8**  
**Seal Kit 26B841, for 120cc Pump Model L0120S8**

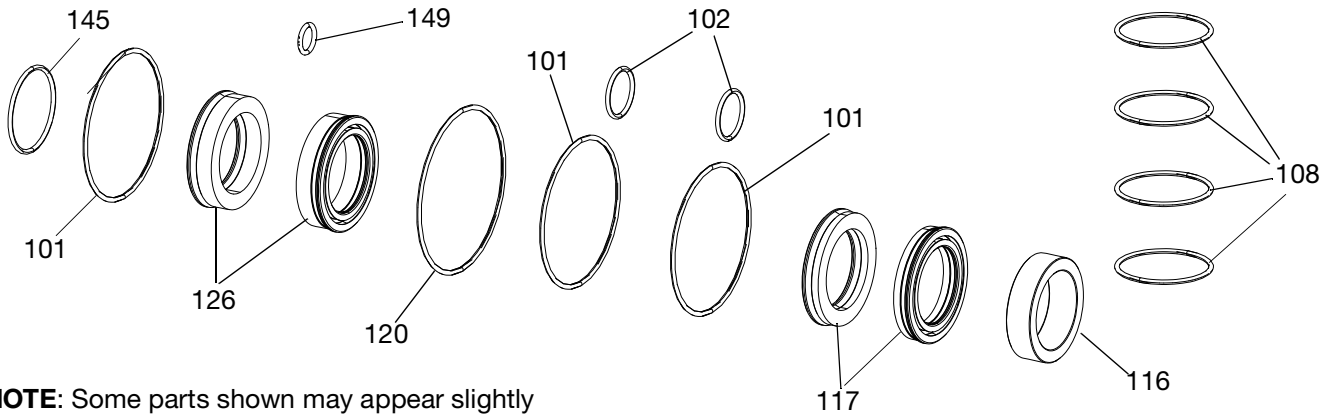

**NOTE:** Some parts shown may appear slightly different in shape and size than actual.

3A8563\_kit 26B841

**FIG. 33**

**Seal Kit 26B847, for 160cc Pump Model L0160S8**

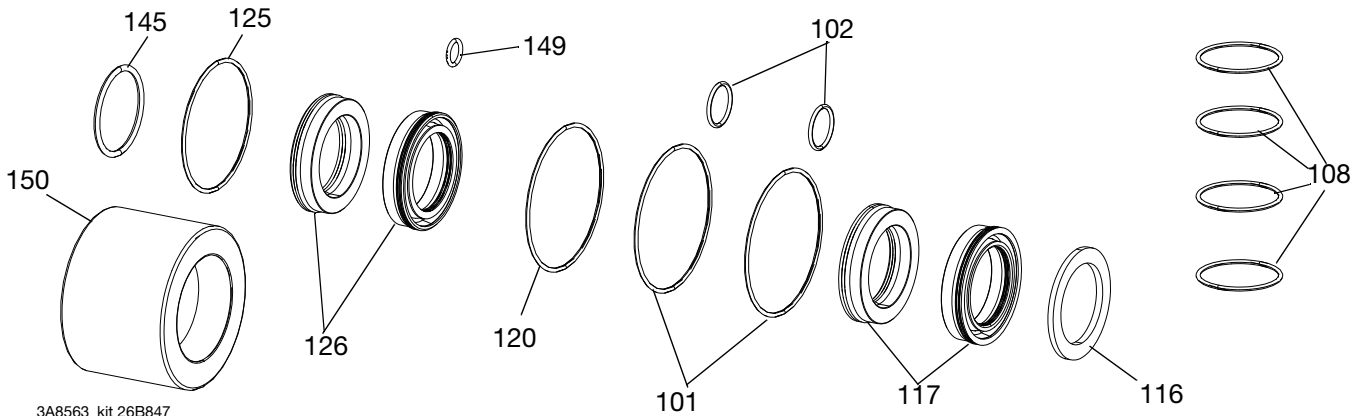

3A8563\_kit 26B847

**FIG. 34**

**Seal Kits, Parts List**

Pump Size	20cc	40cc	80cc	100cc	120cc	160cc
Kit Part No.	26B816	26B822	26B829	26B835	26B841	26B847
	FIG. 31	FIG. 32		FIG. 33		FIG. 34

Ref.	Part	Description	Quantity					
101	106295	PACKING, O-ring	2	2	2	3	3	-
	108823		-	-	-	-	-	2
102	111116	PACKING, O-ring, seat	2	2	2	2	2	2
108	107098	PACKING, O-ring	3	4	4	4	4	4
116	WKO*	BEARING, piston, retainer, pump, H	-	1	1	1	1	1
117	WKO*	SEAL, piston, pump	2	2	2	2	2	2
120	117286	PACKING, O-ring	1	1	1	1	1	1
125	109115	PACKING, O-ring	1	-	-	-	-	-
	113082		-	1	1	-	-	-
	106259		-	-	-	-	-	1

			Pump Size	20cc	40cc	80cc	100cc	120cc	160cc
			Kit Part No.	26B816	26B822	26B829	26B835	26B841	26B847
			FIG. 31	FIG. 32		FIG. 33		FIG. 34	
Ref.	Part	Description	Quantity						
126	WKO*	SEAL, throat, pump, HW	2	-	-	-	2	2	2
	17Y462		-	2	-	-	-	-	
	17Y464		-	-	2	-	-	-	
143	179740	PACKING, O-ring	2	-	-	-	-	-	
145	103610	PACKING, O-ring	1	-	-	-	-	-	
	106553		-	1	-	-	-		
	188555		-	-	1	-	-		
	559013		-	-	-	1	-		
	108559		-	-	-	-	1		
	120901		-	-	-	-	-	1	
149	121399	PACKING, O-ring	1	1	1	1	1	1	
150	18C159	TOOL, displace, rod/cyl, HW	-	-	-	-	-	1	
Not Shown	113500	ADHESIVE, anerobic	1	1	1	1	1	1	
	WKO*	LUBRICANT, anti-seize	1	1	1	1	1	1	
	3A8563	MANUAL	1	1	1	1	1	1	

\* (WKO) With Kits Only. parts are available only as a member of a kit, therefore part number is not shown. Part is included in kit if a quantity is shown.

### Table 4

\*(Reference symbol on main parts list for Displacement Rod Kits)

### Displacement Rod Kits

Displacement Rod Kit 26B817, for 20cc Pump Model L020S8

Displacement Rod Kit 26B823, for 40cc Pump Model L040S8

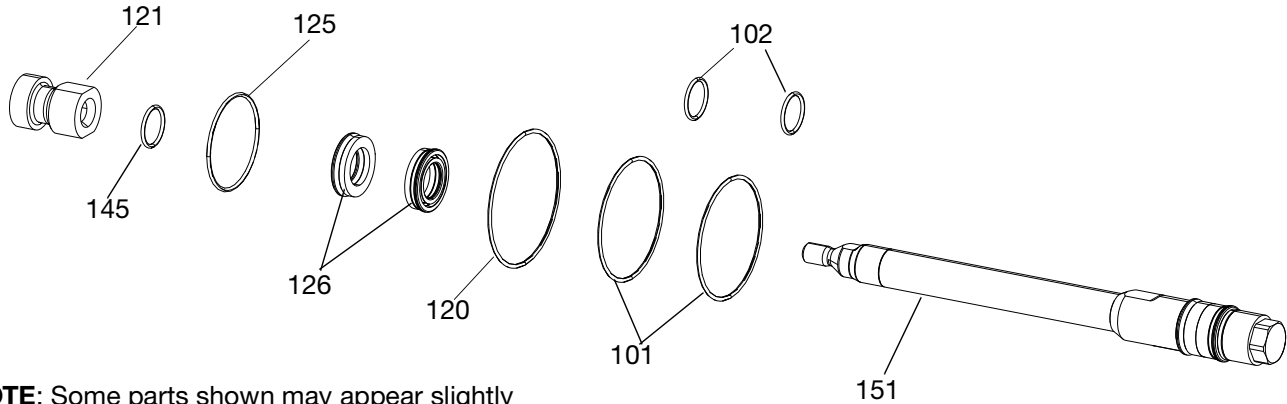

**NOTE:** Some parts shown may appear slightly different in shape and size than actual.

FIG. 35

3A8563\_kit 26B823

### Displacement Rod Kit 26B830, for 80cc Pump Model L080S8

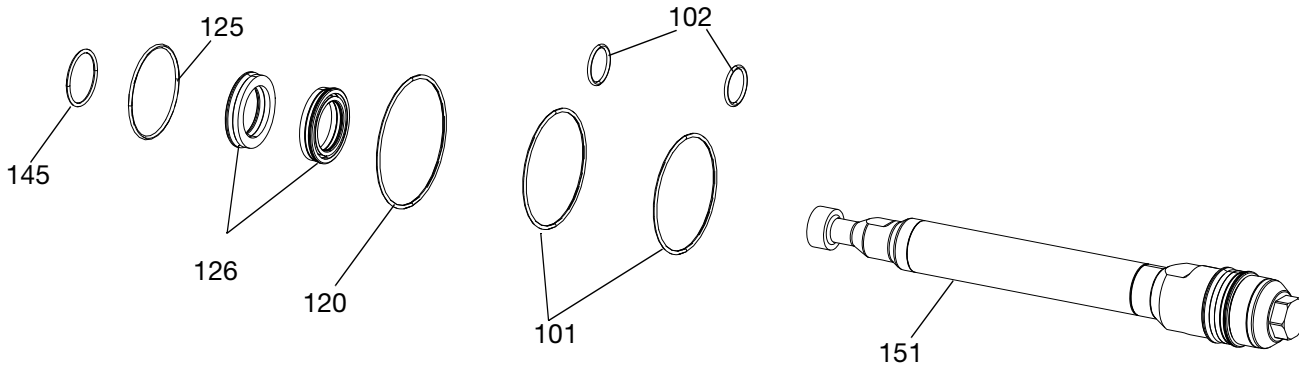
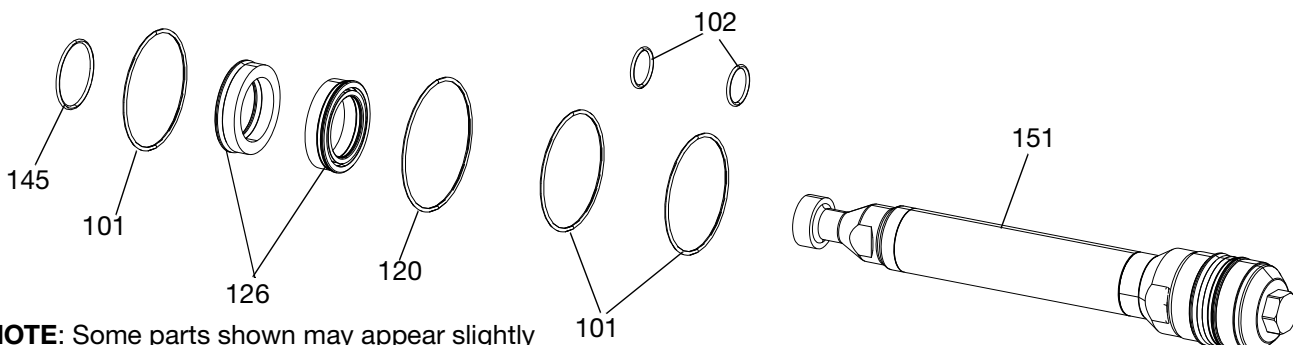

FIG. 36

3A8563\_kit 26B830

### Displacement Rod Kit 26B836, for 100cc Pump Model L0100S8

### Displacement Rod Kit 26B842, for 120cc Pump Model L0120S8



**NOTE:** Some parts shown may appear slightly different in shape and size than actual.

FIG. 37

3A8563\_kit 26B842

**Displacement Rod Kit 26B848, for 160cc Pump Model L0160S8**

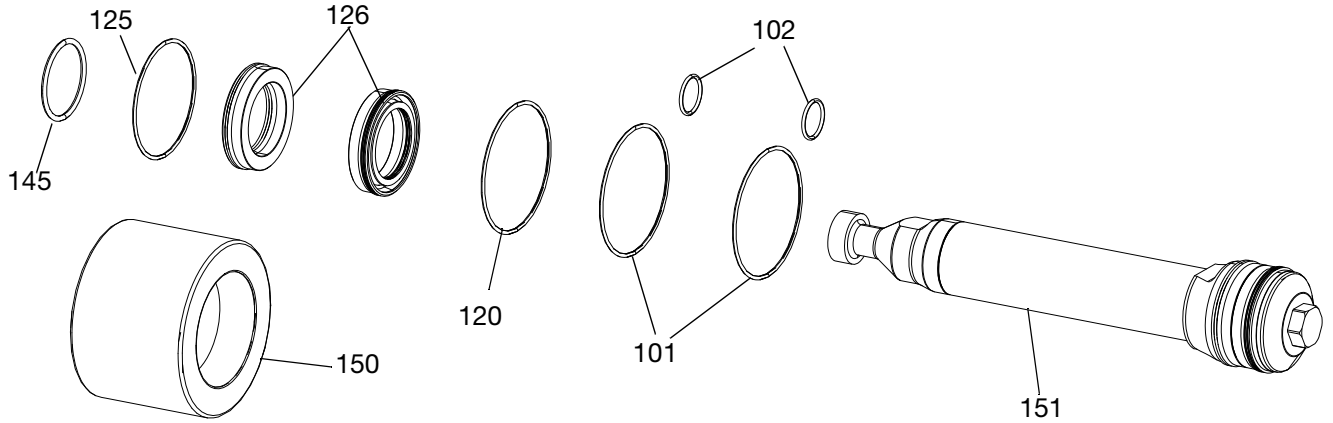

3A8563\_kit 26B848

**FIG. 38**

**Displacement Rod Kits, Parts List**

			Pump Size	20cc	40cc	80cc	100cc	120cc	160cc
			Kit Part No.	26B817	26B823	26B830	26B836	26B842	26B848
				FIG. 35	FIG. 36	FIG. 37	FIG. 37	FIG. 38	FIG. 38
Ref.	Part	Description	Quantity						
101	106259	PACKING, O-ring	2	2	2	3	3	-	
	108823		-	-	-	-	-	2	
102	111116	PACKING, O-ring, seat	2	2	2	2	2	2	
120	117286	PACKING, O-ring	1	1	1	1	1	1	
121	WKO*	ADAPTER, pump shaft, 20 and 40	1	1	-	-	-	-	
125	109115	PACKING, O-ring	1	-	-	-	-	-	
	113082		-	1	1	-	-	-	
	106259		-	-	-	-	-	1	
126	WKO*	SEAL, throat, 20, 100, 120, 160 pump, HW	2	-	-	2	2	2	
	17Y462	SEAL, throat, 40 pump, HW	-	2	-	-	-	-	
	17Y464	SEAL, throat, 80 pump, HW	-	-	2	-	-	-	
145	103610	PACKING, O-ring	1	-	-	-	-	-	
	106553		-	1	-	-	-	-	
	188555		-	-	1	-	-	-	
	559013		-	-	-	1	-	-	
	103559		-	-	-	-	1	-	
	120901		-	-	-	-	-	1	
150	18C159	TOOL, displace , rod,/cyl, 160 HW	-	-	-	-	-	1	

Parts

			Pump Size	20cc	40cc	80cc	100cc	120cc	160cc
			Kit Part No.	26B817	26B823	26B830	26B836	26B842	26B848
			FIG. 35		FIG. 36	FIG. 37		FIG. 38	
Ref.	Part	Description	Quantity						
151	WKO*	ROD, displacement,20 WC, S8	1	-	-	-	-	-	-
		ROD, displacement,40 WC, S8	-	1	-	-	-	-	-
		ROD, displacement,80 WC, S8	-	-	1	-	-	-	-
		ROD, displacement,100 WC, S8	-	-	-	1	-	-	-
		ROD, displacement,120 WC, S8	-	-	-	-	1	-	-
		ROD, displacement,160 WC, S8	-	-	-	-	-	-	1
Not Shown	WKO*	LUBRICANT, anti -seize	1	1	1	1	1	1	1
	113500	ADHESIVE, anerobic	1	1	1	1	1	1	1
	3A8563	MANUAL	1	1	1	1	1	1	1

\* (WKO) With Kits Only. Parts is available only as a member of a kit, therefore part number is not shown. Part is included in kit if a quantity is shown.

## Table 5 Check Valve Kits

From kit to kit, quantities of a given part may vary from that pictured. Refer to quantities shown in the table.

### Check Valve Kit for 20cc Pump Model L020S8

•(Reference symbol on main parts list for Check valve Kits)

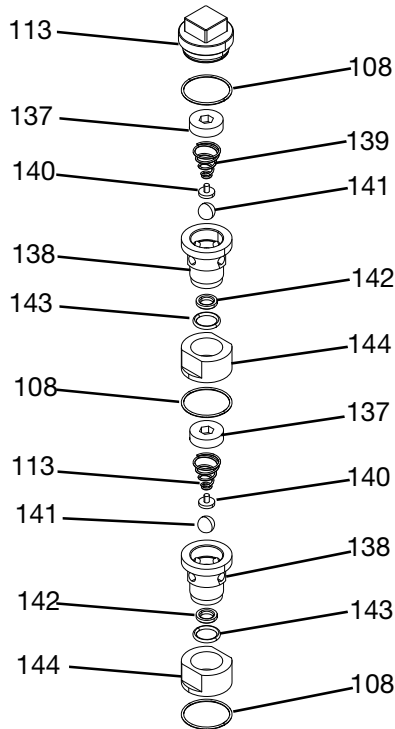

3A8563\_kit chkvlv 20cc

FIG. 39

### Check Valve Kit for 40cc, 80cc, 100cc, 120cc, 160cc pump model L020S8

❖(Reference symbol on main parts list for Check valve Kits)

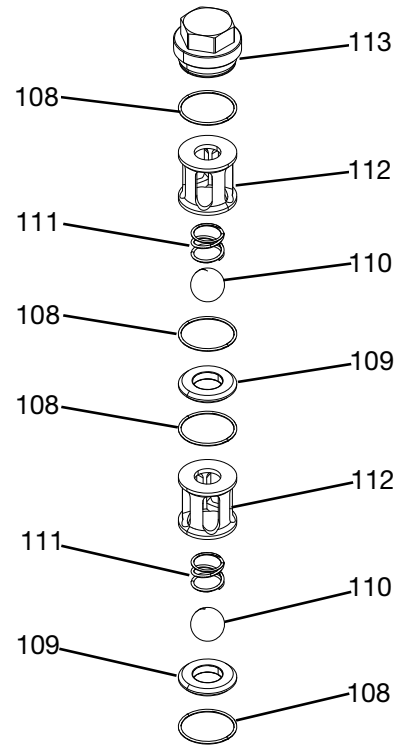

3A8563\_kit chkvlv 20cc

FIG. 40

## Check Valve Kits, Parts List

Pump Size	20cc			40cc, 80cc, 100cc, 120cc, 160cc			
	Kit Part No.	25B123	25B124	26D040	25R749	25R213	25R214
Kit Type	Full	Partial	Special Sharp** Mod	Full	Partial	Housing, Ball Cage Only	Special Sharp** Mod

Ref.	Part	Description	Quantity						
			FIG. 39			FIG. 40			
108	107098	PACKING, O-ring	3	3	3	4	4	-	4
109	15J038	SEAT, carbide	-	-	-	2	2	-	-
	16R879	SEAT, carbide, mod	-	-	-	-	-	-	2
110	17R046	BALL, ceramic, SI-N, 0.875 Dia.	-	-	-	2	2	-	-
	107167	BALL, SST	-	-	-	-	-	-	2
111	122756	SPRING, ball, check	-	-	-	2	-	-	2
112	WKO*	HOUSING, cage, ball, HW	-	-	-	2	-	1	-
	16R880	HOUSING, ball, cage, mod	-	-	-	-	-	-	2
113	WKO*	CAP, inlet, engrave, GB	1	-	1	1	-	-	-

<b>Pump Size</b>	<b>20cc</b>			<b>40cc, 80cc, 100cc, 120cc, 160cc</b>			
<b>Kit Part No.</b>	<b>25B123</b>	<b>25B124</b>	<b>26D040</b>	<b>25R749</b>	<b>25R213</b>	<b>25R214</b>	<b>24U860</b>
<b>Kit Type</b>	<b>Full</b>	<b>Partial</b>	<b>Special Sharp** Mod</b>	<b>Full</b>	<b>Partial</b>	<b>Housing, Ball Cage Only</b>	<b>Special Sharp** Mod</b>
	<b>FIG. 39</b>			<b>FIG. 40</b>			

<b>Ref.</b>	<b>Part</b>	<b>Description</b>	<b>Quantity</b>						
137	WKO*	RETAINER, spring, pump	2	-	2	-	-	-	-
138	WKO*	HOUSING, check valve	2	-	-	-	-	-	-
	WKO*	HOUSING, check valve, glass beads	-	-	2	-	-	-	-
139	WKO*	SPRING, conical, 1 x 0.85 x 0.281, SST	2	2	2	-	-	-	-
140	WKO*	REATAINER, housing, ball	2	2	2	-	-	-	-
141	WKO*	BALL, 0.50 dia., blk	2	2	2	-	-	-	-
142	196832	SEAT, lapped	2	2	-	-	-	-	-
	WKO*	SEAT, sharp, glass beads	-	-	2	-	-	-	-
143	WKO*	PACKING, O-ring	2	2	2	-	-	-	-
144	WKO*	RETAINER, check valve	2	-	2	-	-	-	-

\* (WKO) With Kits Only. parts are available only as a member of a kit, therefore part number is not shown. Part is included in kit if a quantity is shown.

\*\* (Special Sharp) Refers to a special kit for use on application dispensing glass bead-filled product. For example, ball seat has sharp edges.



### Table 6

+(Reference symbol on main parts list for O-ring Inlet Kits)  
**O-Ring Inlet Kit, All Pump Sizes**

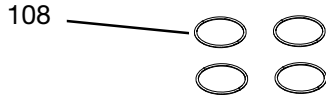

3A8563\_kit O-ring 8

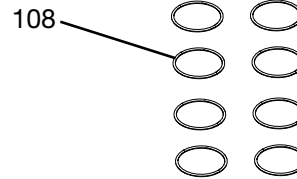

3A8563\_kit O-ring 8

FIG. 41

FIG. 42

### O-Ring Inlet Kit, All Pump Sizes, Parts List

<b>Pump Size</b>	20cc, 40cc, 80cc, 100cc, 120cc, 160cc	
<b>Kit Part No.</b>	258775	258776
	FIG. 41	FIG. 42

Ref.	Part	Description	Quantity	
108	107098	PACKING, O-ring	4	8

## Dimensions

All pump sizes have the same dimensions.

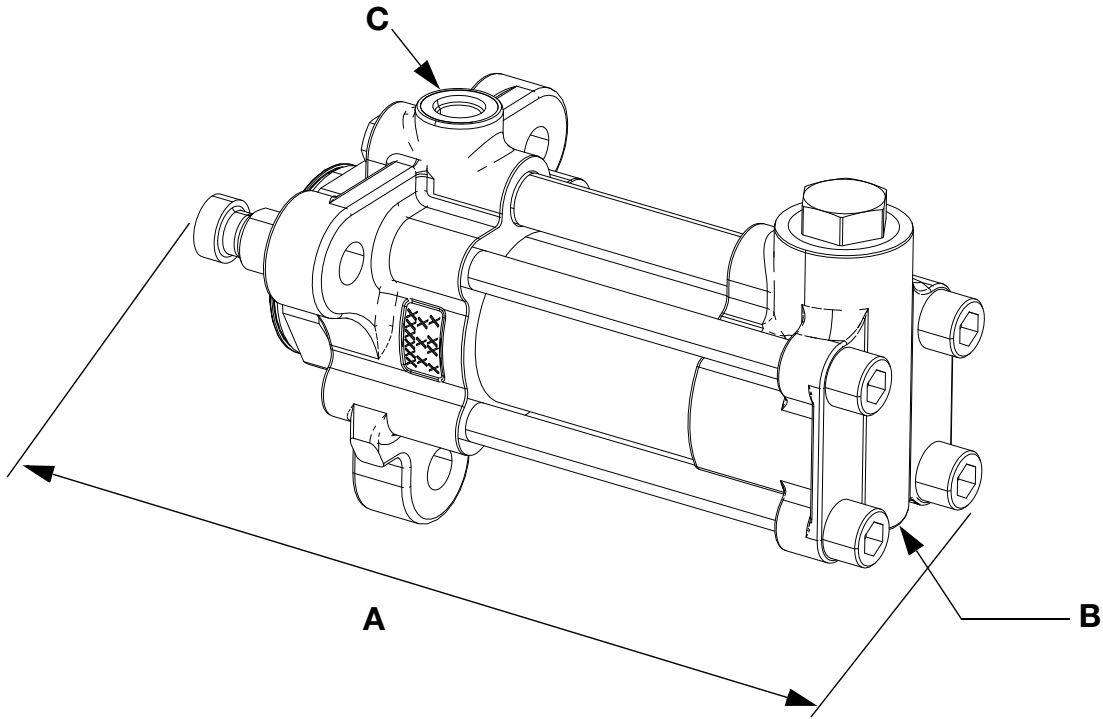

<b>A</b> <b>(Length)</b> in. (mm)	<b>B</b> <b>(Inlet)</b> in. npt (f)	<b>C</b> <b>(Outlet)</b> SAE (f)
13.36 (339.34)	3/4-14	3/4-16

## Outlet Housing Mounting Hole Layout

All pumps have the same outlet housing mounting hole layout.

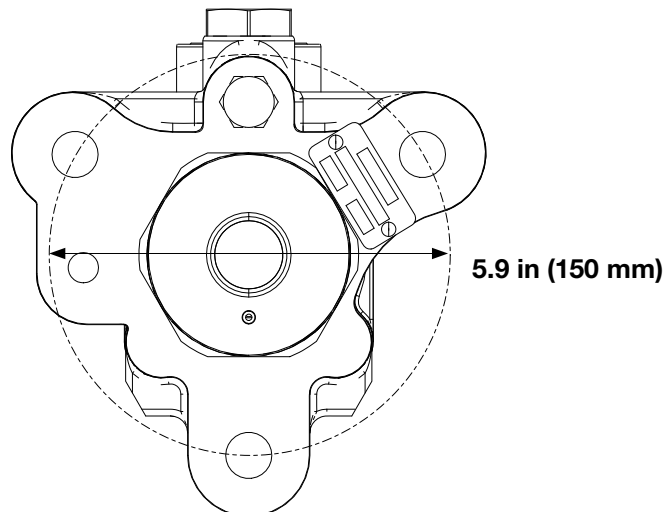

# Technical Specifications

<b>Z-Series Chemical Pumps High Wear</b>		
	<b>US</b>	<b>Metric</b>
Maximum working pressure	3500 psi	24 MPa, 241 bar
Maximum operating temperature	180°F	82°C
Maximum cycle rate	65 cycles per minute	
Minimum feed pressure at inlet	50 psi	0.35 MPa, 3.5 bar
<b>Materials of Construction</b>		
Wetted materials on all models	SST, tungsten carbide, PEEK, PTFE, UHMWPE, silicon nitride	
<b>Weight</b>		
All models	30 lbs	13.6 kg

## California Proposition 65

### CALIFORNIA RESIDENTS

 **WARNING:** Cancer and reproductive harm – [www.P65warnings.ca.gov](http://www.P65warnings.ca.gov).

# Graco Standard Warranty

Graco warrants all equipment referenced in this document which is manufactured by Graco and bearing its name to be free from defects in material and workmanship on the date of sale to the original purchaser for use. With the exception of any special, extended, or limited warranty published by Graco, Graco will, for a period of twelve months from the date of sale, repair or replace any part of the equipment determined by Graco to be defective. This warranty applies only when the equipment is installed, operated and maintained in accordance with Graco's written recommendations.

This warranty does not cover, and Graco shall not be liable for general wear and tear, or any malfunction, damage or wear caused by faulty installation, misapplication, abrasion, corrosion, inadequate or improper maintenance, negligence, accident, tampering, or substitution of non-Graco component parts. Nor shall Graco be liable for malfunction, damage or wear caused by the incompatibility of Graco equipment with structures, accessories, equipment or materials not supplied by Graco, or the improper design, manufacture, installation, operation or maintenance of structures, accessories, equipment or materials not supplied by Graco.

This warranty is conditioned upon the prepaid return of the equipment claimed to be defective to an authorized Graco distributor for verification of the claimed defect. If the claimed defect is verified, Graco will repair or replace free of charge any defective parts. The equipment will be returned to the original purchaser transportation prepaid. If inspection of the equipment does not disclose any defect in material or workmanship, repairs will be made at a reasonable charge, which charges may include the costs of parts, labor, and transportation.

**THIS WARRANTY IS EXCLUSIVE, AND IS IN LIEU OF ANY OTHER WARRANTIES, EXPRESS OR IMPLIED, INCLUDING BUT NOT LIMITED TO WARRANTY OF MERCHANTABILITY OR WARRANTY OF FITNESS FOR A PARTICULAR PURPOSE.**

Graco's sole obligation and buyer's sole remedy for any breach of warranty shall be as set forth above. The buyer agrees that no other remedy (including, but not limited to, incidental or consequential damages for lost profits, lost sales, injury to person or property, or any other incidental or consequential loss) shall be available. Any action for breach of warranty must be brought within two (2) years of the date of sale.

**GRACO MAKES NO WARRANTY, AND DISCLAIMS ALL IMPLIED WARRANTIES OF MERCHANTABILITY AND FITNESS FOR A PARTICULAR PURPOSE, IN CONNECTION WITH ACCESSORIES, EQUIPMENT, MATERIALS OR COMPONENTS SOLD BUT NOT MANUFACTURED BY GRACO.** These items sold, but not manufactured by Graco (such as electric motors, switches, hose, etc.), are subject to the warranty, if any, of their manufacturer. Graco will provide purchaser with reasonable assistance in making any claim for breach of these warranties.

In no event will Graco be liable for indirect, incidental, special or consequential damages resulting from Graco supplying equipment hereunder, or the furnishing, performance, or use of any products or other goods sold hereto, whether due to a breach of contract, breach of warranty, the negligence of Graco, or otherwise.

## **FOR GRACO CANADA CUSTOMERS**

The Parties acknowledge that they have required that the present document, as well as all documents, notices and legal proceedings entered into, given or instituted pursuant hereto or relating directly or indirectly hereto, be drawn up in English. Les parties reconnaissent avoir convenu que la rédaction du présente document sera en Anglais, ainsi que tous documents, avis et procédures judiciaires exécutés, donnés ou intentés, à la suite de ou en rapport, directement ou indirectement, avec les procédures concernées.

# Graco Information

## Sealant and Adhesive Dispensing Equipment

For the latest information about Graco products, visit [www.graco.com](http://www.graco.com).

For patent information, see [www.graco.com/patents](http://www.graco.com/patents).

**TO PLACE AN ORDER**, contact your Graco distributor, go to [www.graco.com](http://www.graco.com), or call to identify the nearest distributor.

**If calling from the USA:** 1-800-746-1334

**If calling from outside the USA:** 0-1-330-966-3000

*All written and visual data contained in this document reflects the latest product information available at the time of publication. Graco reserves the right to make changes at any time without notice.*

Original instructions. This manual contains English. MM 3A8563

**Graco Headquarters:** Minneapolis

**International Offices:** Belgium, China, Japan, Korea

**GRACO INC. AND SUBSIDIARIES • P.O. BOX 1441 • MINNEAPOLIS MN 55440-1441 • USA**  
**Copyright 2020, Graco Inc. All Graco manufacturing locations are registered to ISO 9001.**

[www.graco.com](http://www.graco.com)  
Revision D, January 2023