

StellairTM Auto Air Spray Gun

407194D

EN

Automatic air spray gun for fine finish application of various paints and coatings. For professional use only.

300 psi (2.1 MPa, 21 bar) maximum working fluid pressure.
100 psi (0.7 MPa, 7 bar) maximum working air pressure.



Important Safety Instructions

Read all warnings and instructions in this manual before using the equipment. Be familiar with the proper control and usage of the equipment. Save these instructions.

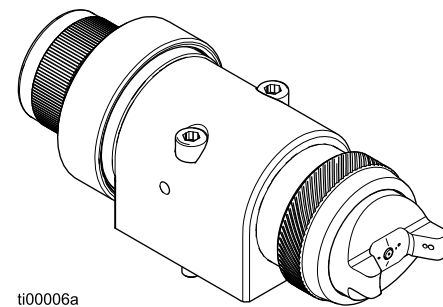
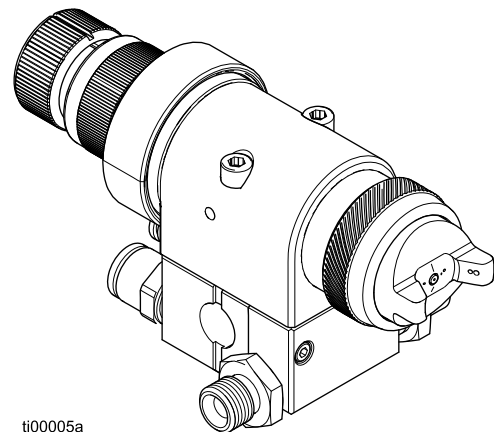

Contents

Models	3
Warnings	4
Installation	6
Ventilate the Spray Booth	6
Grounding	6
Manifold Setup	7
Mount the Gun and Manifold	9
Adjust the True Zero Reference Marks View ...	10
Air Line Installation	11
Fluid Line Installation	12
Setup	13
Position the Air Cap	13
Position the Spray Gun and Workpiece	14
Adjust Spray Pattern	14
Flush Before Using	16
Operation	17
Pressure Relief Procedure	17
Spray Finishing Application	17
Flushing and Cleaning	18
Flushing Procedure	18
Daily Cleaning Procedure	19
Troubleshooting	20
Fluid Troubleshooting	20
Air Troubleshooting	21
Spray Pattern Troubleshooting	22
Repair	24
Prepare Equipment for Service	24
Air Cap Assembly Repair	24
Fluid Cartridge Repair	25
Piston Repair	27
Replace Manifold Seals	28
Fluid Control Knob and Piston Cap Repairs ...	28
Parts	30
Kits and Accessories	32
Fluid Cartridge and Fluid Nozzle Information ...	36
Air Cap and Air Flow	37
Compatible Manifolds	39
Mounting Hole Layout and Dimensions	41
Gun Mounting Kit 24C208	45
Gun Mounting Kit 24B609	45
Retrofit Adapter Plate 288197	45
Single Gun Mounting Bracket 24Y515	46
Dual Gun Mounting Bracket 25A844	46
Robot Adapter Plates	47

Technical Specifications	49
Graco Standard Warranty	50

Approvals



Spray Technology

Conventional: Optimized for excellent finish quality and high production rates.

HVLP: High transfer efficiency gun that limits the air pressure at the air cap to 10 psi (0.07 MPa, 0.7 bar) maximum.

Compliant: High transfer efficiency gun with a transfer efficiency greater than or equal to HVLP guns.

Applications

Operate all guns from delivery systems, such as pressure pots or pumps.

General Industry: Sprays most industrial coatings or finishes used for industrial, automotive, aerospace, marine, wood, plastic, and architectural applications.

Air Brush: Delivers a round spray pattern for precise, small surface area spraying.

Adhesive: Applies waterborne and solventborne adhesives and sealants.

Trim: Delivers a spray pattern with a well-defined edge and minimal overspray for selective coating applications such as edges or trim. Compatible with most industrial coatings, including dielectric materials.

Models

Gun Models with Manifolds

Application	Included Manifold	Nozzle Size in. (mm)	Fluid Control Knob Included	Spray Technology		
				Conventional	HVLP	Compliant
General Industry with Side Inlet Manifold (Inch)	25F155	0.055 (1.4)	✓	25F213	25F215	25F217
				25F212	25F214	25F216
General Industry with Side Inlet Manifold (Metric)	25F315	0.055 (1.4)	✓	25F219	—	—
				25F218	—	—









Gun Models

A manifold is required. See **Compatible Manifolds**, page 39.

Application	Nozzle Size in. (mm)	Fluid Control Knob Included	Spray Technology		
			Conventional	HVLP	Compliant
General Industry	0.030 (0.8)	✓	25F167	25F174	25F181
			25F163	25F170	25F177
General Industry	0.042 (1.1)	✓	25F168	25F175	25F182
			25F164	25F171	25F178
General Industry	0.055 (1.4)	✓	25F169	25F176	25F183
			25F165	25F172	25F179
General Industry	0.070 (1.8)		25F166	25F173	25F180
Air Brush	0.042 (1.1)		25F208	—	—
Air Brush		✓	25F209	—	—
Adhesive	0.051 (1.3)		25F210	—	—
Adhesive	0.07 (1.8)		25F211	—	—
Trim	0.042 (1.1)	✓		25F206	
Trim				25F204	
Trim	0.055 (1.4)	✓		25F207	
Trim				25F205	

Warnings

The following warnings are for the setup, use, grounding, maintenance, and repair of this equipment. The exclamation point symbol alerts you to a general warning and the hazard symbols refer to procedure-specific risks. When these symbols appear in the body of this manual or on warning labels, refer back to these Warnings. Product-specific hazard symbols and warnings not covered in this section may appear throughout the body of this manual where applicable.

 <h1 style="margin: 0;">WARNING</h1>	
   	<p>FIRE AND EXPLOSION HAZARD</p> <p>Flammable fumes, such as solvent and paint fumes, in work area can ignite or explode. Paint or solvent flowing through the equipment can cause static sparking. To help prevent fire and explosion:</p> <ul style="list-style-type: none"> • Use equipment only in well-ventilated area. • Eliminate all ignition sources; such as pilot lights, cigarettes, portable electric lamps, and plastic drop cloths (potential static sparking). • Ground all equipment in the work area. See Grounding, instructions. • Never spray or flush solvent at high pressure. • Keep work area free of debris, including solvent, rags and gasoline. • Do not plug or unplug power cords, or turn power or light switches on or off when flammable fumes are present. • Use only grounded hoses. • Hold gun firmly to side of grounded pail when triggering into pail. Do not use pail liners unless they are anti-static or conductive. • Stop operation immediately if static sparking occurs or you feel a shock. Do not use equipment until you identify and correct the problem. • Keep a working fire extinguisher in the work area.
  	<p>PRESSURIZED EQUIPMENT HAZARD</p> <p>Fluid from the equipment, leaks, or ruptured components can splash in the eyes or on skin and cause serious injury.</p> <ul style="list-style-type: none"> • Follow the Pressure Relief Procedure when you stop spraying/dispensing and before cleaning, checking, or servicing equipment. • Tighten all fluid connections before operating the equipment. • Check hoses, tubes, and couplings daily. Replace worn or damaged parts immediately.
	<p>TOXIC FLUID OR FUMES HAZARD</p> <p>Toxic fluids or fumes can cause serious injury or death if splashed in the eyes or on skin, inhaled, or swallowed.</p> <ul style="list-style-type: none"> • Read Safety Data Sheets (SDSs) to know the specific hazards of the fluids you are using. • Store hazardous fluid in approved containers, and dispose of it according to applicable guidelines.



WARNING



EQUIPMENT MISUSE HAZARD

Misuse can cause death or serious injury.

- Do not operate the unit when fatigued or under the influence of drugs or alcohol.
- Do not exceed the maximum working pressure or temperature rating of the lowest rated system component. See **Technical Specifications** in all equipment manuals.
- Use fluids and solvents that are compatible with equipment wetted parts. See **Technical Specifications** in all equipment manuals. Read fluid and solvent manufacturer's warnings. For complete information about your material, request Safety Data Sheets (SDSs) from distributor or retailer.
- Turn off all equipment and follow the **Pressure Relief Procedure**, when equipment is not in use.
- Check equipment daily. Repair or replace worn or damaged parts immediately with genuine manufacturer's replacement parts only.
- Do not alter or modify equipment. Alterations or modifications may void agency approvals and create safety hazards.
- Make sure all equipment is rated and approved for the environment in which you are using it.
- Use equipment only for its intended purpose. Call your distributor for information.
- Route hoses and cables away from traffic areas, sharp edges, moving parts, and hot surfaces.
- Do not kink or over bend hoses or use hoses to pull equipment.
- Keep children and animals away from work area.
- Comply with all applicable safety regulations.



PERSONAL PROTECTIVE EQUIPMENT

Wear appropriate protective equipment when in the work area to help prevent serious injury, including eye injury, hearing loss, inhalation of toxic fumes, and burns. Protective equipment includes but is not limited to:

- Protective eyewear, and hearing protection.
- Respirators, protective clothing, and gloves as recommended by the fluid and solvent manufacturer.

Installation

Ventilate the Spray Booth



Do not operate the gun unless ventilating air flow is above the minimum required value. Provide fresh air ventilation to avoid the buildup of flammable or toxic vapors when spraying, flushing, or cleaning the gun. Interlock the gun fluid supply to prevent operation unless ventilating air flow is above the minimum required value.

The spray booth must have a ventilation system.

Electrically interlock the gun fluid supply with the ventilators to prevent gun operation any time that the ventilation air flow falls below minimum values. Check and follow all local codes and regulations regarding air exhaust velocity requirements. Verify the operation of the interlock at least once a year.

Grounding



The equipment must be grounded to reduce the risk of static sparking. Static sparking can cause fumes to ignite or explode. Grounding provides an escape wire for the electric current.

The following grounding instructions are minimum requirements for a system. Your system may include other equipment or objects that must be grounded. Check your local electrical code for detailed grounding instructions for your area and type of equipment. Your system must be connected to a true earth ground.

Spray Gun: Ground the spray gun by mounting it to a grounded mount, such as a reciprocator, robot, or stationary support, and connect the gun to a properly grounded fluid hose and pump.

Pump: Ground the pump by connecting a ground wire and clamp between the pump and a true earth ground as instructed in your separate pump instruction manual.

Air Compressors and Hydraulic Power Supplies: Ground air compressors and hydraulic power supplies according to the manufacturer recommendations.

Air, Fluid, and Hydraulic Hoses Connected To Pump: Use only electrically conductive hoses with a maximum of 100 ft (30.5 m) combined hose length to ensure grounding continuity. Check the electrical resistance of your air and fluid hoses at least once a week. If the total resistance to ground exceeds 25 megohms, replace the hose immediately. Use a meter that is capable of measuring resistance at this level.

Fluid Supply Container: Ground the fluid supply container according to local code and regulations.

Object Being Sprayed: Ground the object that is being sprayed according to local code and regulations.

Solvent Pails: Ground all solvent pails used during the **Flushing Procedure** according to local code. Use only metal pails, which are conductive. Do not place the pail on a non-conductive surface, such as paper or cardboard, which interrupts the grounding continuity.

Manifold Setup

Manifold connection locations vary by manifold. See **Compatible Manifolds**, page 39 for manifold part details.

Install Air Fittings on the Manifold

Manifold connection locations vary by manifold. See **Compatible Manifolds**, page 39 for manifold part details.

1. Install a tube fitting (104) into the cylinder air inlet (CYL).
2. Install a tube fitting (105) into the fan air inlet (FAN) and the atomizing air inlet (ATOM).

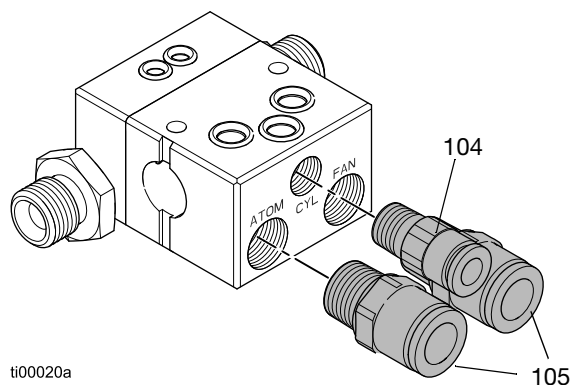

ti00020a

FIG. 1: Air Fittings and Fluid Supply Inlets

Install Fluid Connectors and Gun on the Manifold

Circulating System Configuration

1. Apply anti-seize lubricant 222955 to the mating faces of the manifold and the fluid connector threads (102).
2. Install the fluid connector fitting (102) in the fluid ports (FLP). See FIG. 1.

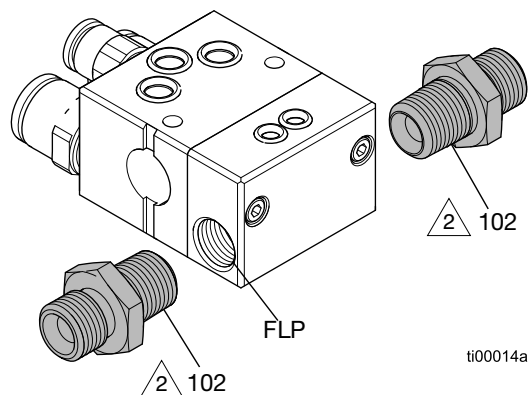

ti00014a

 Apply anti-seize lubricant

FIG. 2: Fluid Port Connections (Circulating Configuration)

3. Connect the fluid supply hose to one fluid connector fitting (102) and the fluid return hose to the other connector (102). See **Gun Fluid Line Installation**, page 12.
4. Remove the internal fluid plug (17). See FIG. 4.
5. Install the two fluid o-rings (108) supplied with the manifold.

NOTE: The fluid ports (FLP) are reversible.

6. Lubricate the manifold o-rings (107 and 108) with the recommended **Light-Weight Oil**, page 35.

- Secure the gun to the manifold with the mounting screws (4). Torque to 65 in-lb (7.3 N•m)

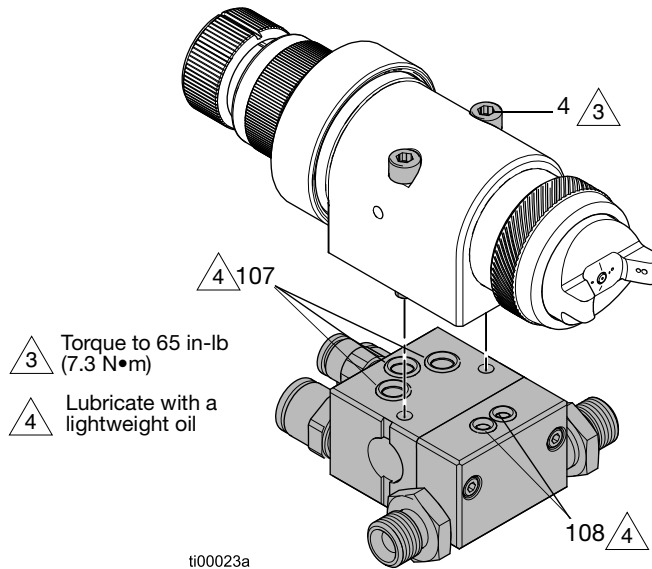
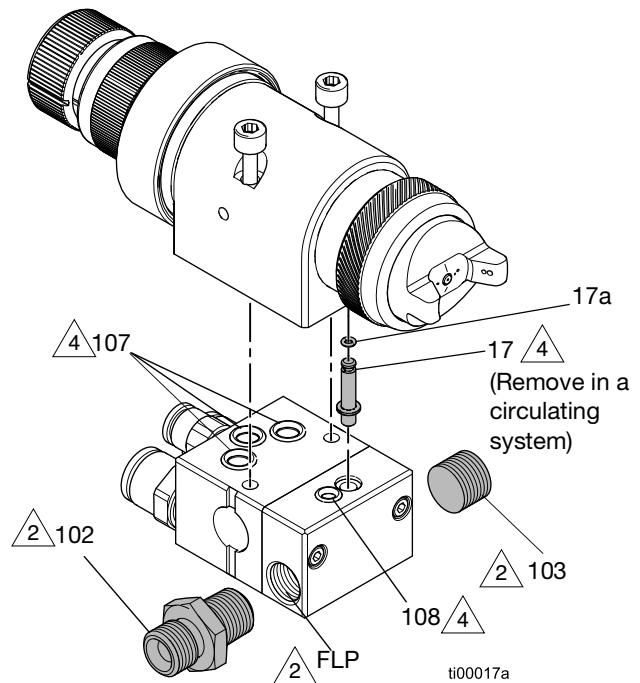

FIG. 3: Mounting Screw Location

Non-Circulating System Configuration

- Apply anti-seize lubricant 222955 to the fluid port (FLP) threads, fluid connector thread (102), and the pipe plug (103).
- Install a fluid connector fitting (102) in one fluid port, and a pipe plug (103) in the other port.

- Connect the fluid supply hose to the fluid connector fitting (102). See **Gun Fluid Line Installation** on page 12.



- △ 2 Apply anti-seize lubricant
- △ 4 Lubricate with recommended **Light-Weight Oil**

FIG. 4: Fluid Port Connections (Non-Circulating Systems)

- Lubricate and install the internal fluid plug (17) with o-ring (17a) in the gun fluid port on the same side as the pipe plug (103). Use the recommended **Light-Weight Oil**, page 35.
- Install one fluid o-ring (108) in the manifold fluid port opposite the internal fluid plug.

NOTE: Make sure to remove the fluid o-ring (108) before installing the internal fluid plug (17).

Mount the Gun and Manifold

Reciprocating Arm Rod Mount Installation

The gun fits a 0.5 in. (13 mm) diameter maximum reciprocating arm rod.

1. Insert a mounting bar (MB) through the hole in the manifold.
2. Tighten the set screw (106) to secure the gun to the manifold.

NOTE: The manifold notches (MN) fit 1/8 in. alignment pins. Use as desired.

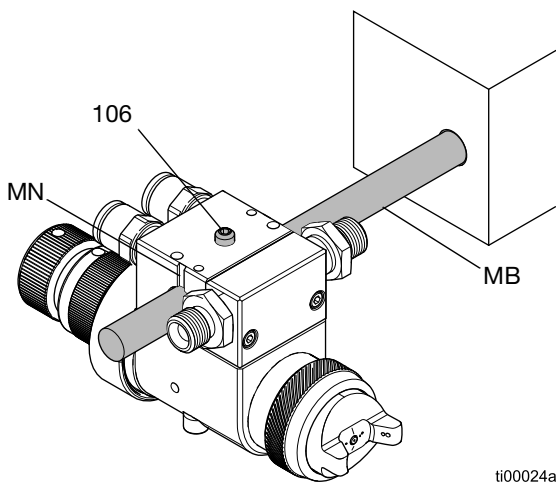

FIG. 5: Reciprocating Arm Mount

Stationary Support Installation

Mount the gun on a stationary support or robot mounting bracket. Refer to the **Mounting Hole Layout and Dimensions**, page 41 for the manifold measurements and screw hole depth.

1. Tighten or remove the setscrew (106) with a hex key.
2. Locate alignment pins and holes per the **Mounting Hole Layout and Dimensions** illustration, page 41.
3. Align the manifold with alignment pins (AP).
4. Secure the gun to the support with capscrews (CS).

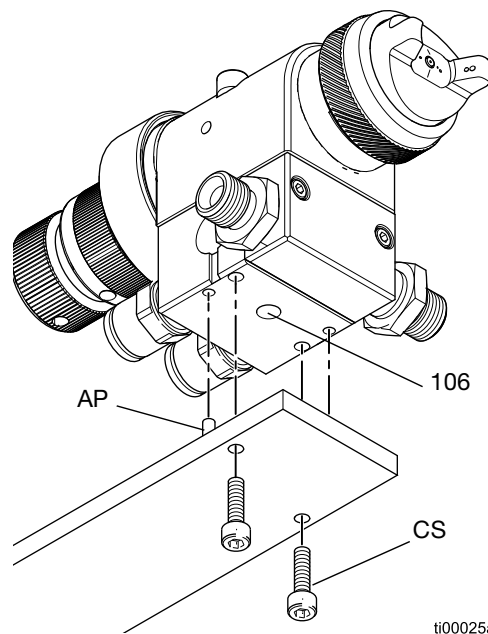

FIG. 6: Stationary Support Mount

Adjust the True Zero Reference Marks View

Optional Setup: Gun models with a fluid control knob (8) have a true zero set point. See **True Zero Reference Checklist**, page 28.

If desired, rotate the fluid control knob assembly so the operator can see the reference marks (M1 and M2). Use a hex key to adjust set screws.

1. Turn the fluid control knob (8) counter-clockwise until it stops.

NOTICE

Use caution when closing the fluid control knob. The needle tip may be damaged if forced too hard against the nozzle seat by the fluid control knob.

2. Slightly loosen the piston cap set screw (5a).

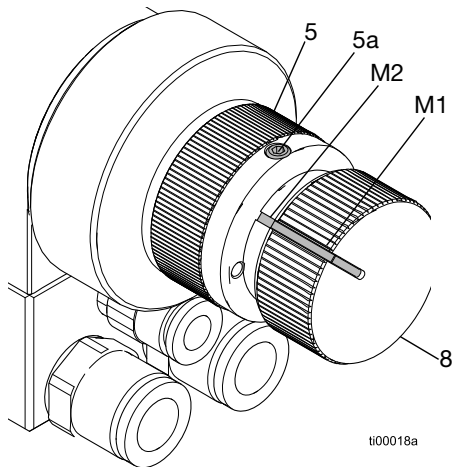





FIG. 7: Piston Set Screw Location

3. Rotate the fluid control knob assembly so the true zero marking (M2) is visible.
4. Tighten the piston cap set screw (5a).
5. **Reset Gun to True Zero**, page 29.

Air Line Installation

Main Air Line Typical Installation

				
<p>Trapped air can cause the gun to spray unexpectedly, which could result in serious injury from splashing fluid. To help prevent injury, install a bleed-type master air valve.</p>				

- **Bleed-type master air valve:** required in your system to relieve air trapped between the pump and the gun when the valve is closed.

NOTE: Be sure the valve is easily accessible from the pump and located downstream from the air regulator.

- **Pump air pressure regulator:** to control pump speed and fluid outlet pressure. Locate it close to the pump.
- **Air line filter:** removes harmful dirt and moisture from compressed air supply. Ensures a dry, clean air supply.
- **Air shutoff valve:** shuts off air to the gun and pump.

Gun Air Hose Installation

Connect air hoses to the gun cylinder (CYL), fan (FAN), and atomizing (ATOM) air connectors.

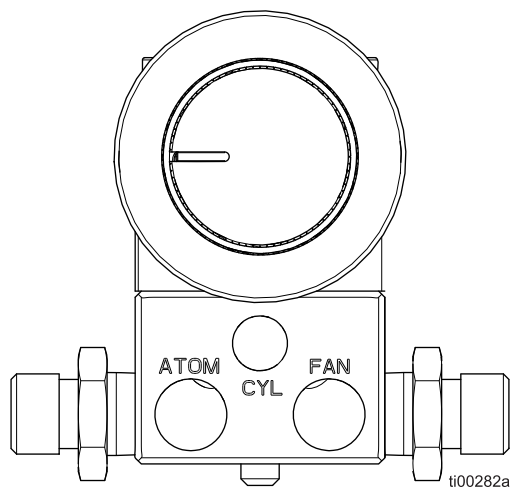

FIG. 8: Cylinder, Fan, and Atomizing Connections

Manifolds with three air inlets: Supply and regulate each air line separately.

Manifolds with a fan adjustment valve: Supply and regulate the fan and atomizing air with one air connection.

1. Connect an air hose (D) to each air fitting. Use 3/8 in. (9.5 mm) O.D. tubing for fan and atomizing air to minimize excessive pressure drop in the hoses.

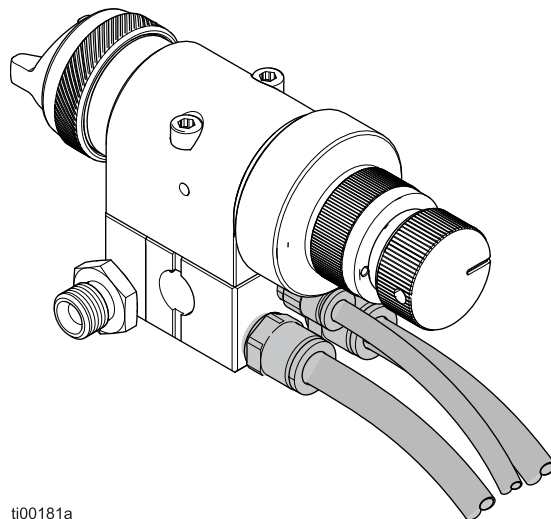

FIG. 9: Gun Air Hose Connections

2. Install an air pressure regulator (F) on each gun air hose.

NOTE: The fan and atomizing air regulators must have a minimum air flow capacity of 30 scfm at 100 psi (0.7 MPa, 7.0 bar) air pressure.

3. Install a bleed-type air shutoff valve (E) on each gun air hose. Install downstream of the gun air regulator to shut off air to the gun.
4. Connect each gun air hose (D) to the main air supply line.

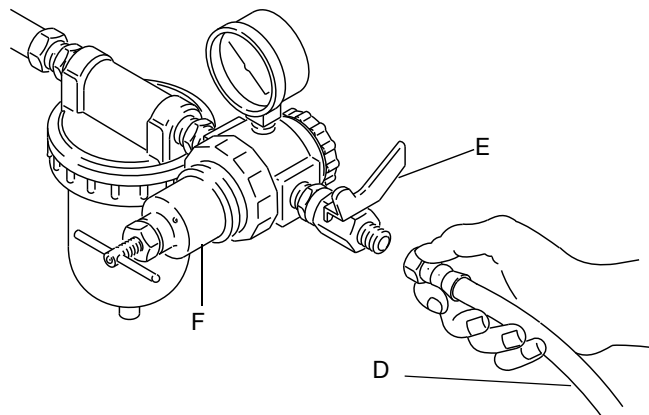

FIG. 10: Gun Air Hose Typical Installation

Fluid Line Installation

Main Fluid Line Installation

- **Fluid filter:** with a 60 or 100 mesh (250 micron) stainless steel element to filter particles from the fluid as it leaves the pump. Always use a clean fluid filter.
- **Fluid drain valve:** relieves fluid pressure in the hose and gun. Required in your system to assist in relieving fluid pressure in the displacement pump, hose and gun; triggering the gun to relieve pressure may not be sufficient.
- **Fluid shutoff valve:** shuts off fluid flow. Can be installed in the fluid line to the gun.
- **Fluid pressure regulator:** for more precise adjustment of the fluid pressure. Install a fluid pressure regulator on the main fluid line if the pump's maximum working pressure exceeds the gun's maximum fluid working pressure. See **Technical Specifications**, page 49.

Gun Fluid Line Installation

Before connecting the fluid hose, blow it out with air and flush it with solvent. Use solvent that is compatible with the fluid to be sprayed.

1. Install a fluid pressure regulator (L) on the gun fluid hose.

NOTE: Some applications require fine-tuned control of fluid pressure. You can control fluid pressure more accurately with a fluid pressure regulator than by regulating the air pressure to the pump.

2. Install a fluid shutoff valve (M) on the gun fluid line to shut off the fluid supply to the gun.

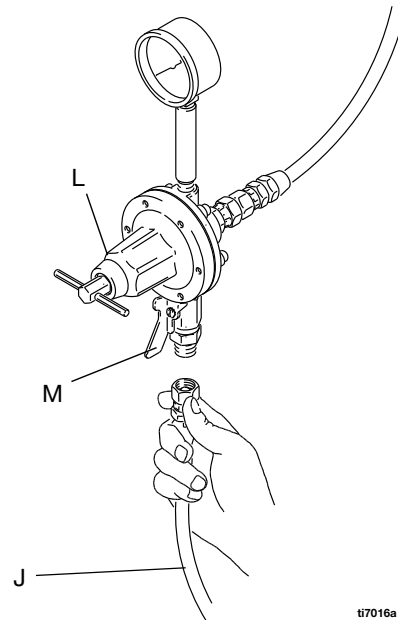

FIG. 11: Gun Fluid Line Typical Installation

3. Connect the gun fluid supply hose (J) to a gun fluid connector fitting (102). In a circulating system, connect the fluid return hose to the other fluid connector (102).

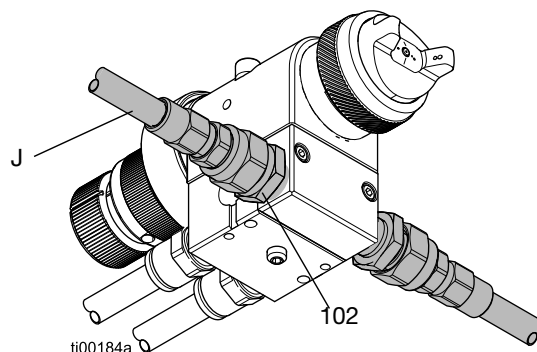

FIG. 12: Fluid Supply and Fluid Return Connections

Setup

Position the Air Cap

NOTE: Air Brush air caps do not include alignment pins.

Vertical Spray Pattern

Air caps are factory-set with the alignment pin set to a vertical spray pattern.

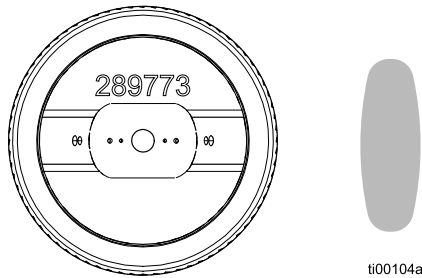

FIG. 13: Vertical Spray Pattern (Factory-Set Position)

Horizontal Spray Pattern

To change the air cap to a horizontal spray pattern, use a hex key to unscrew the alignment pin and relocate it to the horizontal spray pattern hole. When relocating the pin use low strength thread locker. Torque to 1.5–2.5 in-lb (0.2–0.3 N•m). Do not overtighten.

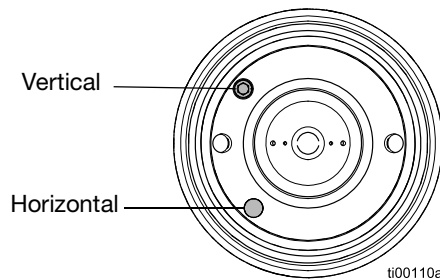

FIG. 14: Air Cap Alignment Pin Positions

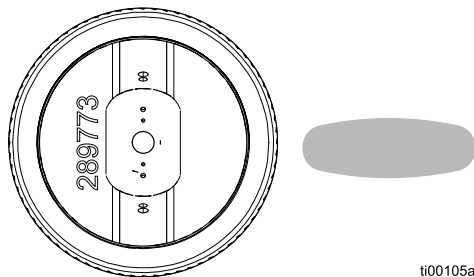

FIG. 15: Horizontal Spray Pattern

Angled Spray Pattern

Use the gauge on the **Alignment Tool: 2000481** to quickly set precise spray pattern angles. The alignment tool is sold separately. See **Alignment Tool: 2000481**, page 34.

1. Tighten the assembled air cap onto the gun body.
2. Place the alignment tool onto the gun.

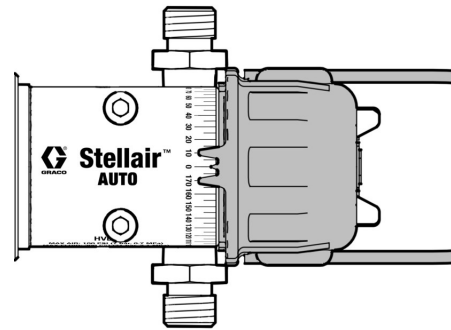

FIG. 16: Alignment Tool on an Air Cap in the Vertical Position (0°)

3. Rotate the alignment tool to the desired angled spray pattern position.

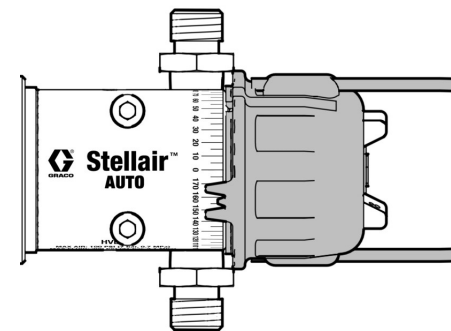

FIG. 17: 160° Angled Spray Pattern

4. Remove the tool before spraying.

Position the Spray Gun and Workpiece

The 8 in. (300 mm) path guides on the **Alignment Tool: 2000481** help visualize the spray center point and the distance between the gun and the workpiece. The alignment tool is sold separately. See **Alignment Tool: 2000481**, page 34.

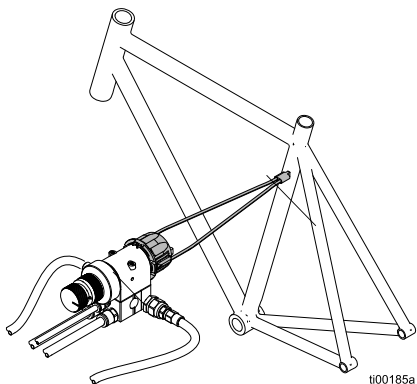

FIG. 18: Alignment Tool Path Guides

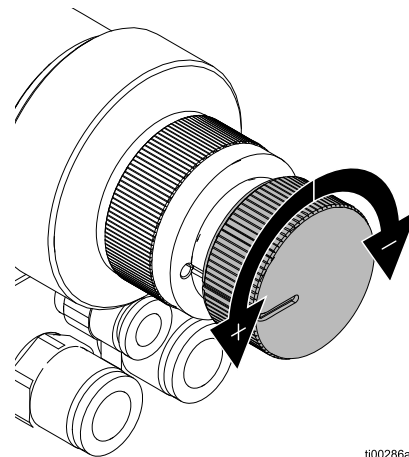

FIG. 19: Fluid Control Knob Adjustments

Adjust Spray Pattern

Set Fluid Flow

1. Adjust the Fluid Pressure Regulator (L) to set the fluid flow rate. Typical industrial flow rates will vary with regulator pressures from 5–30 psi (34–210 kPa, 0.3–2.1 bar).
2. Supply a minimum of 50 psi (0.34 MPa, 3.4 bar) air pressure to the cylinder (CYL) air line to trigger the gun.
3. Make fluid flow adjustments.
 - **Fluid Regulator (L):** Increase or decrease the fluid pressure to achieve desired flow rate.
 - **Fluid Control Knob (8) (select models):** make fine adjustments to the flow with the fluid control knob.
 - **Open:** Turn counter-clockwise to increase the fluid flow.
 - **Close:** Turn clockwise to decrease.

NOTICE

Use caution when operating the fluid control knob near the closed position. The needle tip may be damaged if forced too hard against the nozzle seat by the fluid control knob.

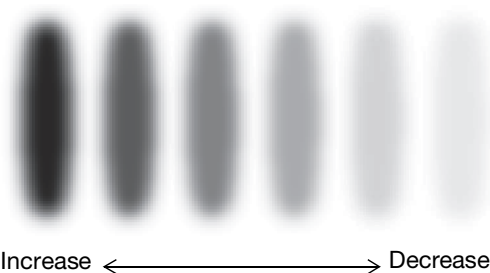

FIG. 20: Fluid Flow Coverage

- **Adjust nozzle size:** Check fluid pressure and change nozzle if needed. See **Fluid Cartridge and Fluid Nozzle Information, page 36**.
 - If the fluid pressure is too high at the desired flow rate, install a larger nozzle.
 - If the fluid pressure is too low at the desired flow rate, install a smaller nozzle.

NOTE: A larger fluid nozzle at a reduced fluid pressure will maintain the same flow rate, but the fluid stream (velocity) will slow down. When air is applied, the lower velocity allows the air to act on the fluid longer, which improves atomization.

Supply Fan and Atomizing Air

Use the air pressure regulator (F) to set the fan and atomizing air pressure. Use the **Recommended Starting Pressures** as a starting point. Note **Maximum Fan and Atomizing Manifold Inlet Pressure Requirements**, page 15.

Recommended Starting Pressures

Application and Technology	Fan Air psi (MPa, bar)	Atomizing Air psi (MPa, bar)	*Fan Pattern Width 100ccm, 20cps	*Fan Pattern Width 100ccm, 100cps
General Industry: Conventional	25 (0.17, 1.7)	25 (0.17, 1.7)	12	8
General Industry: HVLP	25 (0.17, 1.7)	25 (0.17, 1.7)	12	9
General Industry: Compliant	25 (0.17, 1.7)	25 (0.17, 1.7)	13.5	13
Trim: HVLP	10 (0.07, 0.7)	10 (0.07, 0.7)	9.5	8
Adhesive	20 (0.14, 1.4)	20 (0.14, 1.4)	5	5
Air Brush	20 (0.14, 1.4)	20 (0.14, 1.4)	N/A	N/A

* Pattern created from a 10 in. spray distance, using a 0.055 in. (1.4 mm) nozzle orifice.

Maximum Fan and Atomizing Manifold Inlet Pressure Requirements

Application and Technology	Maximum Fan Air Pressure psi (MPa, bar)	Maximum Atomizing Air Pressure psi (MPa, bar)
General Industry: HVLP	29 (0.20, 2.0)	17 (0.12, 1.2)
General Industry: Compliant	33 (0.23, 2.3)	29 (0.20, 2.0)
Trim: HVLP	14 (0.0965, 965)	12 (0.08, 0.8)

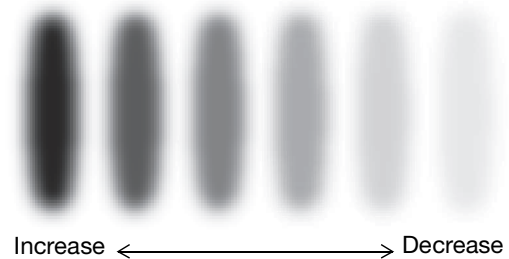

ti00113a

FIG. 21: Atomizing Air

Adjust Fan Air

If the spray pattern is too wide or split, reduce the fan air pressure (or slightly close the fan adjustment valve on the manifold if using manifold 2000226). Note **Maximum Fan and Atomizing Manifold Inlet Pressure Requirements** for HVLP and compliant guns.

Test Fan and Atomizing Air

Test the spray pattern while keeping the gun a consistent distance, about 6–8 in. (150–200 mm), from the test piece. Adjust atomizing and fan air as needed.

Adjust Atomizing Air

For the best transfer efficiency, use the lowest setting needed to achieve desired finish quality.

Increase the gun atomizing air supply pressure with the air pressure regulator in 5 psi (34 kPa, 0.3 bar) increments until you obtain the desired atomization. Note **Maximum Fan and Atomizing Manifold Inlet Pressure Requirements** for HVLP and compliant guns.

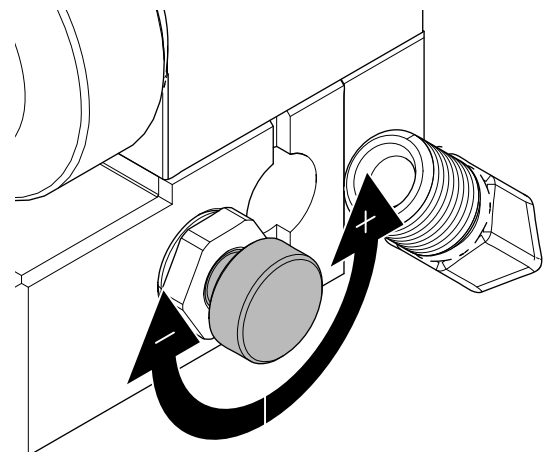

ti00477a

FIG. 22: Fan Air

Setup

To further control the spray pattern, use an alternate air cap. See **Air Cap and Air Flow**, page 37.

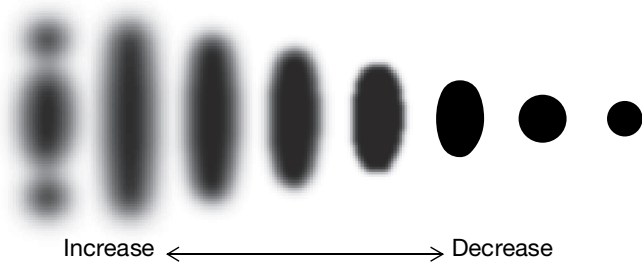

FIG. 23: Fan Air

HVLP and Compliant Gun Limits

In some areas, an HVLP gun is required for compliance with environmental standards. To comply with HVLP requirements, the air pressure at the air cap must be less than 10 psi (0.07 MPa, 0.7 bar).

See **Air Cap and Air Flow**, page 37 for maximum HVLP and Compliant manifold inlet pressures. To verify the pressure at the air cap, use an appropriate **HVLP Pressure Verification Kit**, page 35.

Flush Before Using

The equipment was tested with lightweight oil, which is left in the fluid passages to protect parts. To avoid contaminating your fluid with oil, flush the equipment with a compatible solvent before using the equipment. See **Flushing Procedure**, page 18.

Operation

Pressure Relief Procedure

 Follow the Pressure Relief Procedure whenever you see this symbol.



This equipment stays pressurized until pressure is manually relieved. To help prevent serious injury from pressurized fluid, such as splashing fluid, follow the Pressure Relief Procedure when you stop spraying and before cleaning, checking, or servicing the equipment.

1. Turn off the fluid supply to the gun.
2. Turn off the fan and atomizing air supply to the gun.
3. Trigger the gun into a grounded metal waste container to relieve the pressure.
4. Turn off the cylinder air supply to the gun.
5. Close the bleed-type master air valve (required in the system).
6. Open the fluid drain valve (required in the system) to relieve fluid pressure in the gun and hose. In addition, relieve fluid pressure in the fluid supply equipment as instructed in its instruction manual. Have a container ready to catch the drainage. Leave all drain valves open until you are ready to spray again.
7. If you suspect that the nozzle or hose is completely clogged or that pressure has not been fully relieved:
 - a. Very slowly loosen the fluid hose end coupling to relieve pressure gradually.
 - b. Loosen the coupling completely.
 - c. Clear the obstruction in the hose or nozzle.

Spray Finishing Application

When triggered, the gun begins emitting air before the fluid discharges. When the cylinder air stops, the fluid stops before the airflow stops. This lead and lag operation helps ensure proper spray atomization and prevents fluid buildup on the air cap.

1. **Adjust Spray Pattern.** See page 14.
2. Position the workpiece. Adjust the system control device, if it is automatic, so the gun starts spraying just before meeting the workpiece and stops as soon as it passes.
3. Keep the gun perpendicular and 6–8 in. (150–200 mm) from the workpiece.
4. Supply a minimum of 50 psi (0.34 MPa, 3.4 bar) air pressure to the cylinder (CYL) air line to trigger the gun.
5. Use smooth, parallel strokes across the workpiece surface with 50 percent overlap.

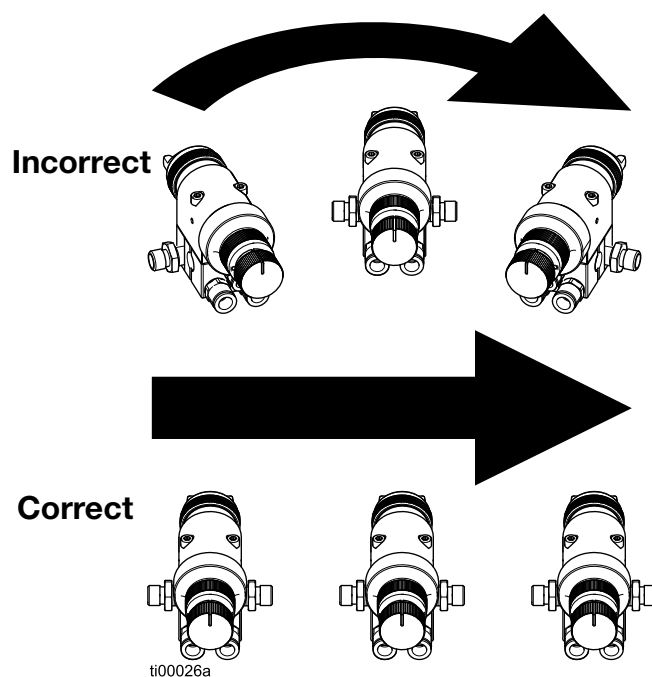
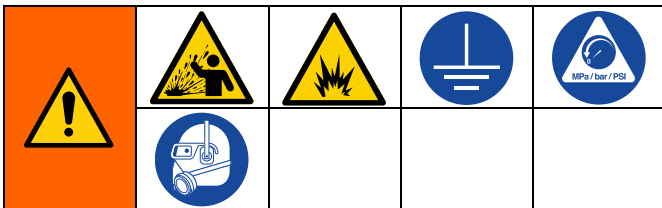

FIG. 24: Correct Spray Method

6. Flush the equipment. See **Flushing and Cleaning**, page 18.

Flushing and Cleaning



To reduce the risk of an injury from splashing fluid, follow the **Pressure Relief Procedure**, page 17, whenever you are instructed to relieve the pressure.

To avoid fire and explosion, always ground equipment and waste container. To avoid static sparking and injury from splashing fluid, always flush at the lowest possible pressure.

- Follow the **Daily Cleaning Procedure** every day.
- Flush before changing colors, before fluid can dry in the equipment, at the end of the day, before storing, and before repairing equipment.
- Flush at the lowest pressure possible. Check connections for leaks and tighten as necessary.
- Flush with a fluid that is compatible with the fluid being dispensed and the equipment wetted parts.

NOTICE

Methylene chloride with formic or propionic acid is not recommended as a flushing or cleaning solvent with this gun as it will damage aluminum and nylon components.

- Clean the front of the air cap regularly to reduce buildup.
- Do not use any cleaning method which may allow solvent into the gun air passages. Solvent left in gun air passages could result in a poor quality paint finish.
 - Do not point gun up while cleaning.
 - Do not wipe the gun with a cloth soaked in solvent; wring out the excess.
 - Do not immerse the gun in solvent.

Flushing Procedure

1. Follow the **Pressure Relief Procedure**, page 17.
2. Connect a solvent supply hose to the gun.
3. To maintain grounding continuity hold metal part of the spray gun firmly to the side of a grounded metal solvent pail.
4. Turn on the gun cylinder (CYL) air.
5. Starting with the lowest possible fluid pressure, trigger the gun into a grounded metal solvent pail.
6. Increase the fluid pressure slowly. Flush until clean solvent flows from the gun.

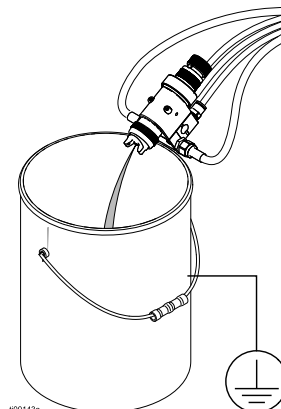

Fig. 25: Flushing into a Grounded Metal Container

7. De-trigger the gun.
8. Turn off the solvent supply.
9. Follow the **Pressure Relief Procedure**, page 17.

Daily Cleaning Procedure

1. Follow the **Pressure Relief Procedure**, page 17.
2. Flush the equipment. See **Flushing Procedure**, page 18.
3. Remove the air cap assembly. See **Remove the Air Cap Assembly**, page 24.
4. Dip the end of a soft-bristle brush into a compatible solvent. Do not continuously soak the brush's bristles.

NOTICE

Do not use metal tools to clean the air cap assembly parts. Metal tools may scratch the air cap and cause spray pattern distortion.

5. Clean the components. Replace seals as needed.
 - a. Clean the parts with a soft-bristle brush.
 - b. Use a soft tool, such as an unclogging needle or tooth pick, to clean the air cap (6) holes.

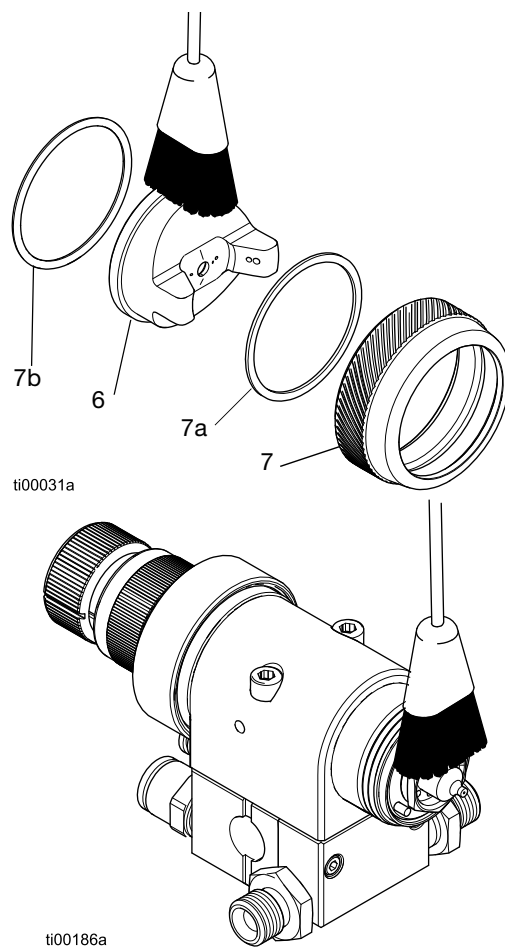

FIG. 26: Clean Air Cap Components

6. Dampen a soft cloth with solvent and wring-out the excess. Point the gun down and wipe off the outside of the gun.
7. Assemble and install the air cap assembly. See **Install the Air Cap Assembly**, page 24.

Troubleshooting



1. Follow the **Pressure Relief Procedure**, page 17 before checking or repairing the gun.
2. Check all possible problems and causes before disassembling gun.

Fluid Troubleshooting

Problem	Cause	Solution	Reference	
Fluid leakage through venting holes	Worn fluid cartridge seals	Replace the fluid cartridge or the seals	Fluid Cartridge Repair , page 25	
	Worn, dirty, or damaged fluid needle	Replace the fluid cartridge or the fluid needle		
	Loose packing nut	Replace the fluid cartridge or tighten packing nut		
Fluid leakage from front of gun	Fluid needle tip is dirty, worn, or damaged	Replace the fluid cartridge	Fluid Cartridge Repair , page 25	
		Clean or replace fluid needle tip or entire needle	FIG. 30: Needle Assembly , page 25	
	Dirty or worn nozzle	Replace the fluid cartridge	Fluid Cartridge Repair , page 25	
		Clean or replace nozzle	FIG. 31: Nozzle and Fluid Insert , page 25	
Fluid is present at air cap holes	Nozzle is insufficiently tightened	Tighten the fluid cartridge	Install the Fluid Cartridge , page 25	
		Tighten the nozzle	FIG. 31: Nozzle and Fluid Insert , page 25	
Fluid does not flow Fluid needle will not trigger	Insufficient cylinder (CYL) air pressure supplied to the gun on trigger	Increase cylinder (CYL) air pressure or clean the air line	Air Line Installation , page 11	
	Missing ball bearing from the piston	Replace the ball bearings	Check Piston Ball Bearings , page 27	
	Air leaking around piston	Replace piston o-ring or piston	Replace Piston Seals , page 27	
	Swollen piston o-ring	Replace piston o-ring.	Piston Repair , page 27	
	Internal fluid plug is incorrectly installed	Non-Circulating System: Move plug to fluid port consistent with manifold plumbing		FIG. 4: Fluid Port Connections (Non-Circulating Systems) , page 8
		Circulating System: All fluid ports in gun and on manifold should be open		FIG. 2: Fluid Port Connections (Circulating Configuration) , page 7

Problem	Cause	Solution	Reference
Fluid does not shut off	Worn or swollen piston seals	Replace piston seals.	Piston Repair , page 27
	Piston cap not fully tightened	Tighten piston cap until it bottoms out	
	Piston spring not in place	Check spring position	

Air Troubleshooting

Problem	Cause	Solution	Reference
Air leakage through venting hole	Worn air cap seals	Replace the air cap seals	Service the Air Cap Parts , page 24
Air leakage from back of gun	Worn piston seals	Replace piston seals	Piston Repair , page 27
Air does not trigger	Piston stem is disconnected from main body of piston assembly	Reinstall the piston assembly	
	Cylinder air pressure is too low	Increase cylinder air pressure to 50 psi	Air Line Installation , page 11
Air does not shut off	Piston assembly not seating properly	Service the piston assembly	Piston Repair , page 27
	Broken return spring	Replace return spring	
	Worn or swollen piston stem seals	Replace seals	

Spray Pattern Troubleshooting

Problem	Cause	Solution	Reference
Fluid flow is fluttering while spraying	Fluid nozzle is not tight enough	Tighten fluid nozzle to 35–45 in-lb (4–5 N•m)	FIG. 34: Nozzle and Fluid Insert , page 25
	Fluid cartridge o-ring is missing or damaged	Replace fluid cartridge o-ring	FIG. 34: Fluid Cartridge Assembly , page 26
	Clogged fluid hose filter	Check fluid hose filter	Fluid Line Installation , page 12
	The retaining ring assembly is not fully threaded or coupled to the gun body	Tighten the retaining ring assembly	Install the Air Cap Assembly , page 24
	Air cap seals are damaged	Replace the seals	Service the Air Cap Parts , page 24
Fluid flow fades while spraying high viscosity fluids	Fluid pressure is too low, causing fluid flow to reduce when gun is elevated	Raise fluid pressure at source	Set Fluid Flow , page 14
		Use a smaller orifice size fluid nozzle or fluid cartridge	FIG. 31: Nozzle and Fluid Insert , page 25
	The retaining ring assembly is not fully threaded or coupled to the gun body	Tighten the retaining ring assembly	Install the Air Cap Assembly , page 24
Pattern becomes off-set or heavy on ends	The retaining ring assembly is not fully threaded or coupled to the gun body	Tighten the retaining ring assembly	Install the Air Cap Assembly , page 24
	Plugged air cap horn holes	Clean the air cap	Daily Cleaning Procedure , page 19
	Dirty air cap seals		
	Damaged air cap horn holes	Replace the air cap	FIG. 27: Air Cap Assembly , page 24
Damaged air cap seals	Replace the air cap seals		
Gun fluid pressure is too high with gun triggered	Fluid cartridge orifice is too small.	Use a larger orifice size fluid nozzle or fluid cartridge	FIG. 28: Fluid Cartridge Assembly , page 25
Fluid system will not operate below 10 psi (70 kPa, 0.7 bar)	There is no fluid regulator	Install a low pressure fluid regulator	Fluid Line Installation , page 12
	Air regulator to the pressure pot is not sensitive enough at low pressures	Install a more sensitive, low pressure air regulator on pressure pot	Air Line Installation , page 11
Air cap becomes dirty immediately after spraying	Gun atomizing air is off	Turn on gun atomizing air	Supply Fan and Atomizing Air , page 14
	Plugged nozzle or air cap air holes	Clean the air cap, nozzle, or the gun	Daily Cleaning Procedure , page 19
	Damaged air cap	Replace the air cap	Service the Air Cap Parts , page 24
	Damaged air cap seals	Replace the air cap seals	Service the Air Cap Parts , page 24
	Damaged nozzle	Replace the nozzle or the fluid cartridge	FIG. 34: Fluid Cartridge Assembly , page 26

Problem	Cause	Solution	Reference
Pattern shape looks like a banana	Plugged air cap hole	Clean the air cap	Daily Cleaning Procedure , page 19
	Dirty air cap		
	Dirty nozzle	Clean the nozzle	Daily Cleaning Procedure , page 19
	Damaged air cap	Replace the air cap	Service the Air Cap Parts , page 24
	Damaged nozzle	Replace the nozzle	FIG. 34: Nozzle and Fluid Insert , page 25
	Missing baffle	Replace the baffle	FIG. 28 , page 25
Turning on fluid pressure turns off the fluid flow, and turning off air pressure turns on the fluid flow.	Fan or atomizing air pressure is too high	Adjust the fan and atomizing air pressure	Supply Fan and Atomizing Air , page 14
	The air cap is not fully seated on the nozzle	Tighten the retaining ring	FIG. 27: Air Cap Assembly , page 24
	Damaged fluid nozzle	Replace the fluid nozzle or the fluid cartridge	FIG. 34: Fluid Cartridge Assembly , page 26
	Fluid pressure is too low	Adjust the fluid pressure	Set Fluid Flow , page 14

Repair

				
<p>To reduce the risk of an injury from splashing fluid, follow the Pressure Relief Procedure, whenever you are instructed to relieve the pressure.</p>				

Prepare Equipment for Service

1. Follow the **Pressure Relief Procedure**, page 17.
2. Follow the **Flushing Procedure**, page 18.
3. Turn off system air.

Air Cap Assembly Repair

Remove the Air Cap Assembly

1. **Prepare Equipment for Service.** See page 24.
2. Loosen the air cap retaining ring (7) to remove the air cap assembly (6).

Service the Air Cap Parts

1. Remove the retaining ring seal (7b) with a pick.
2. Remove the air cap (6) and washer (7a) from the retaining ring (7).
3. Clean the components and replace as needed.
4. Assemble the air cap and retaining ring.
 - a. Install the washer (7a) into the retaining ring (7).
 - b. Install the air cap (6) into the retaining ring (7).
 - c. Install the retaining ring seal (7b).

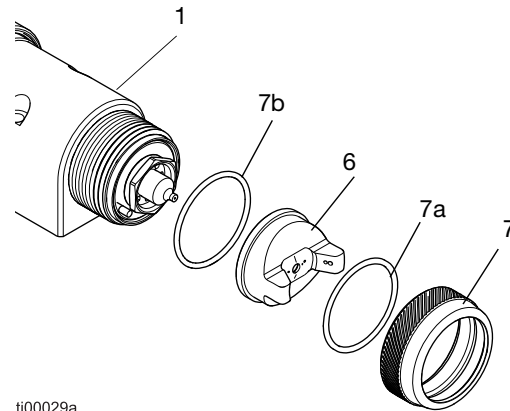

ti00029a

Fig. 27: Air Cap Assembly

Install the Air Cap Assembly

1. Tighten the assembled air cap (7) onto the gun body (1).
2. Set the air cap position. See **Position the Air Cap**, page 13.

Fluid Cartridge Repair

Remove the Fluid Cartridge

1. **Prepare Equipment for Service.** See page 24.
2. **Remove the Air Cap Assembly.** See page 24.
3. Use a wrench or a gun tool to remove the fluid cartridge (2). See FIG. 28.
4. Remove the baffle (19), if needed.

Install the Fluid Cartridge

Lubricate components with the recommended **Light-Weight Oil** on page 35.

1. Ensure the baffle (19) is in place. The flat side of the baffle faces away from the gun body.
2. Lubricate the seals (2d and 2e).
3. Use a wrench or gun tool to tighten the assembled fluid cartridge (2) into the gun body. Torque to 35–45 in-lb (4–5 N•m).

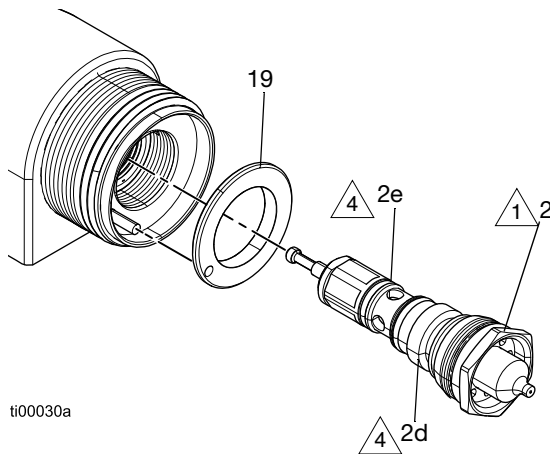

1 Torque to 35–45 in-lb (4–5 N•m)

4 Lubricate with recommended **Light-Weight Oil**

FIG. 28: Fluid Cartridge Assembly

Disassemble the Fluid Cartridge

1. Remove the fluid cartridge (2) from the gun. See FIG. 28.
2. Separate the fluid needle (18) from the fluid cartridge.

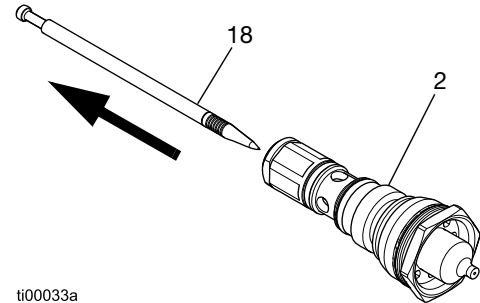

FIG. 29: Fluid Cartridge and Fluid Needle

3. Replace the needle tip (18a) as needed. Apply medium-strength threadlocker to the needle threads before installing the tip replacement.

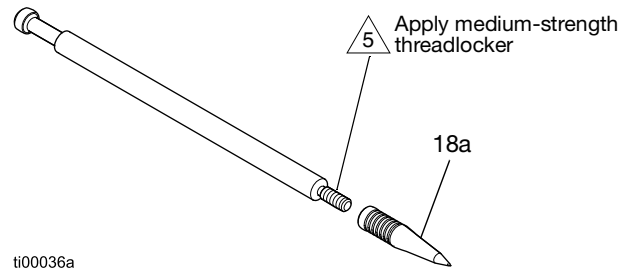

FIG. 30: Needle Assembly

4. Decouple the fluid nozzle (2a) and fluid insert (2b).

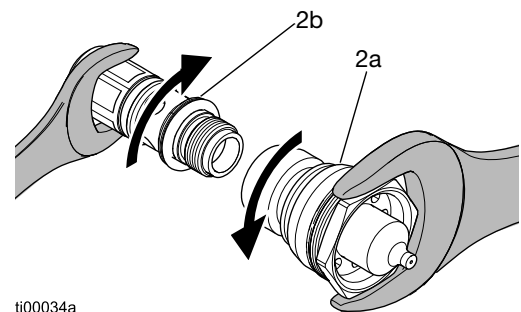
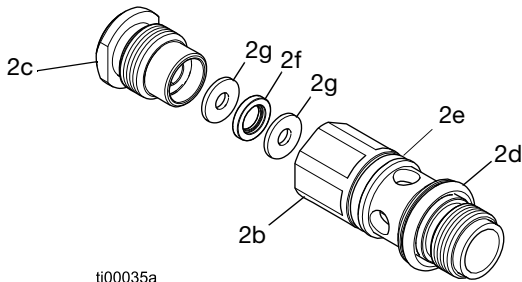

FIG. 31: Nozzle and Fluid Insert

- Decouple the packing nut (2c) and the fluid insert (2b).



ti00035a

FIG. 32: Fluid Insert and Packing Nut

- Remove the washers (2g) and packing seal (2f) from the packing nut (2c).
- Use a pick to remove the fluid insert o-ring seals (2d and 2e).

Assemble the Fluid Cartridge

Replace parts as needed and assemble the fluid cartridge. Lubricate components with the recommended **Light-Weight Oil** on page 35.

- Replace the fluid insert o-ring seals (2e and 2d).
- Assemble the washers (2g) and packing seal (2f) into the packing nut (2c). Note the packing seal (2f) orientation in FIG. 33. Apply lubricant to the center of the assembled packing nut.

- Install the assembled packing nut (2c) into the fluid insert. Torque the packing nut (2c) to 80 in-lb (9 N•m).

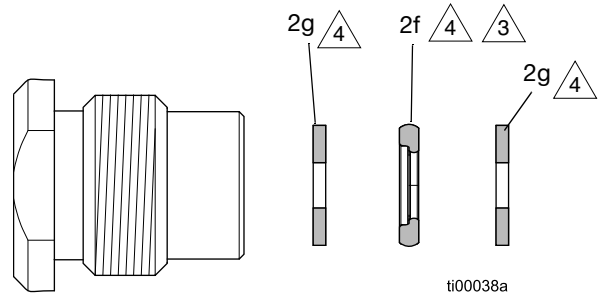

ti00038a

- △4 Lubricate with recommended **Light-Weight Oil**
- △3 The step on the packing seal faces into the packing nut

FIG. 33: Spacer Orientation

- Install the nozzle (2a) onto the fluid insert (2b). Torque to 120-130 in-lb (14-15 N•m). See FIG. 31.
- Install the needle (18) into the fluid cartridge. See FIG. 29.
- Lubricate the seals (2e and 2d).
- Install the fluid cartridge (2) into the gun body. Torque to 35-45 in-lb (4-5 N•m). See FIG. 28.

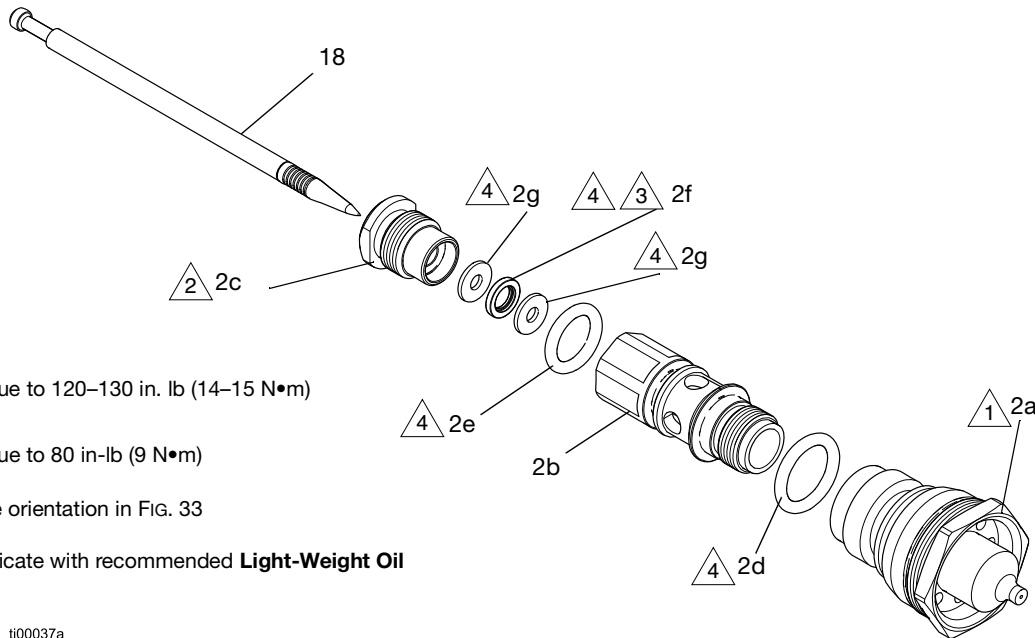

- △1 Torque to 120-130 in. lb (14-15 N•m)
- △2 Torque to 80 in-lb (9 N•m)
- △3 Note orientation in FIG. 33
- △4 Lubricate with recommended **Light-Weight Oil**

ti00037a

FIG. 34: Fluid Cartridge Assembly

Piston Repair

Do not immerse the piston (3) in solvent. Lubricate components with the recommended **Light-Weight Oil** on page 35.

Disassemble the Piston

1. **Prepare Equipment for Service.** See page 24.
2. Loosen piston cap (5) and remove the cap (5), springs (11 and 16), and spring guide (9).
3. Use pliers to slowly pull the piston assembly from the gun housing to avoid losing the ball bearings (3e).

Check Piston Ball Bearings

Ensure the piston ball bearings (3e) did not fall out of the piston (3). If the ball bearings fall out, reinstall and lubricate before assembling the piston.

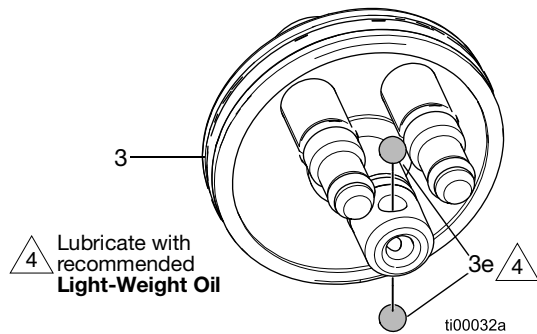

FIG. 35: Piston Ball Bearings Location

Replace Piston Seals

Use **Kit 2000515: Piston Seals** on page 34 to replace the piston seals.

1. Remove piston seals with a pick.
2. Replace and lubricate the piston seals.

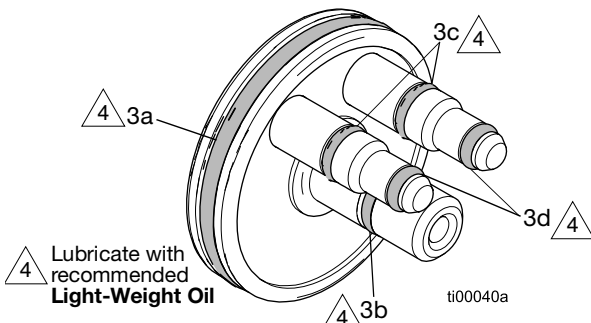

FIG. 36: Piston Seals Location

Install the Piston

1. Ensure the ball bearings (3e) are in place. See FIG. 35.
2. Lubricate piston seals and ball bearings.
3. Push the piston (3) into the gun body.
4. Lubricate and install the spring guide (9) into the piston (3).
5. Install the fluid spring (11).
6. Install the air spring (16).
7. Tighten the piston cap (5) onto the gun.
8. Reset to true zero if needed. See **Reset Gun to True Zero**, page 29.

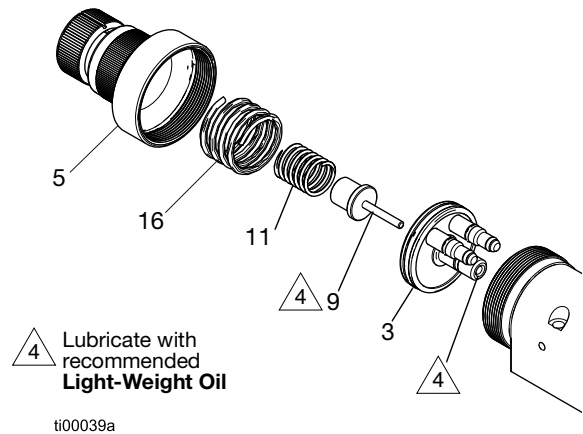

FIG. 37: Piston Assembly

Replace Manifold Seals

Use **Kit 2000517: Manifold Seals** on page 34 to replace the manifold seals (107 and 108). Lubricate components with the recommended **Light-Weight Oil** on page 35.

1. **Prepare Equipment for Service.** See page 24.
2. Loosen the mounting screws (4) to remove the gun from the manifold.

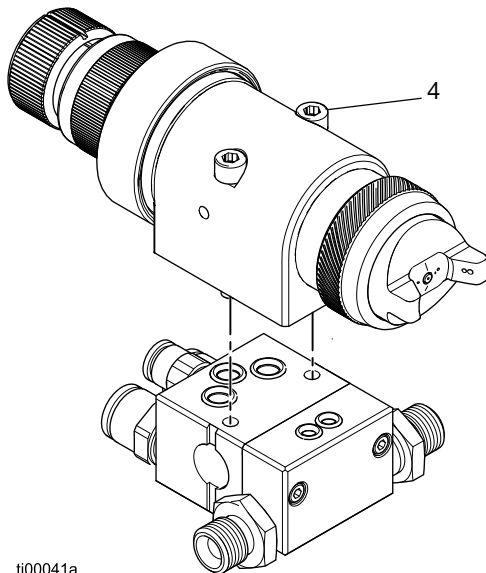
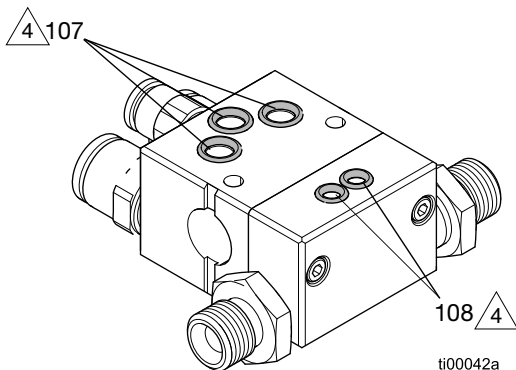

FIG. 38: Manifold Mounting Screws

3. Remove seals with a pick and replace.
4. Lubricate seals (107 and 108) before installing the gun.

NOTE: If using a circulating system configuration, two o-rings are used. If using a non-circulating system configuration, one o-ring and an internal fluid plug are used.



4 Lubricate with recommended **Light-Weight Oil**

FIG. 39: Manifold Seal Location

Fluid Control Knob and Piston Cap Repairs

Add a Fluid Control Knob

Use **Kit 2000516: Fluid Control Knob Assembly** to add the fluid control knob feature to the gun.

1. **Prepare Equipment for Service.** See page 24.
2. Loosen piston cap (5) and remove the cap (5), springs (11 and 16), and spring guide (9).
3. Assemble the gun as shown in FIG. 37.
4. Check the true zero reference marks and reset to true zero as needed.

True Zero Reference Checklist

Guns with a fluid control knob (8) have a true zero setpoint. When a gun is set to true zero, fluid flow stops when the fluid control knob is completely closed.

- The fluid control knob (8) is completely closed
- No fluid flows from the gun
- The reference marks align

Reset Gun to True Zero

Check the **True Zero Reference Checklist**, page 28 and reset the gun to true zero as need.

1. **Install the Fluid Cartridge.** See page 25.
2. Firmly tighten the piston cap (5).
3. Turn the fluid control knob (8) clockwise until it stops to close the knob.

NOTICE

Use caution when closing the fluid control knob. The needle tip may be damaged if forced too hard against the nozzle seat by the fluid control knob.

4. Use a hex key to loosen the fluid control knob set screw (8a).
5. Align the line marks (M1 and M2) on the fluid control knob (8). See FIG. 40.
6. Tighten the set screw (8a).

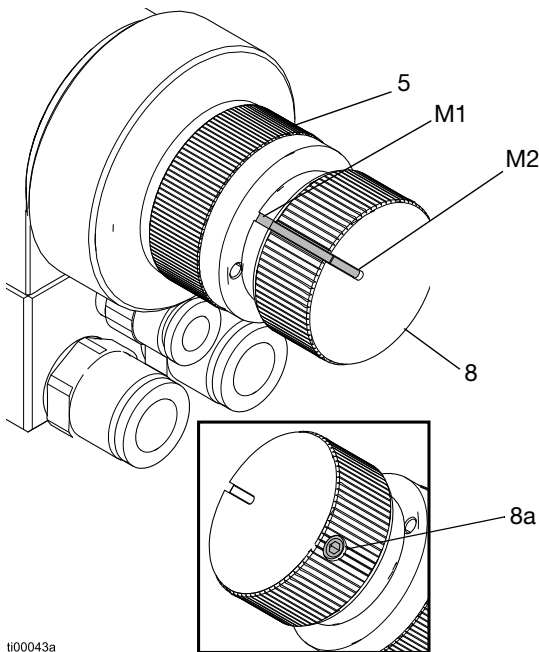
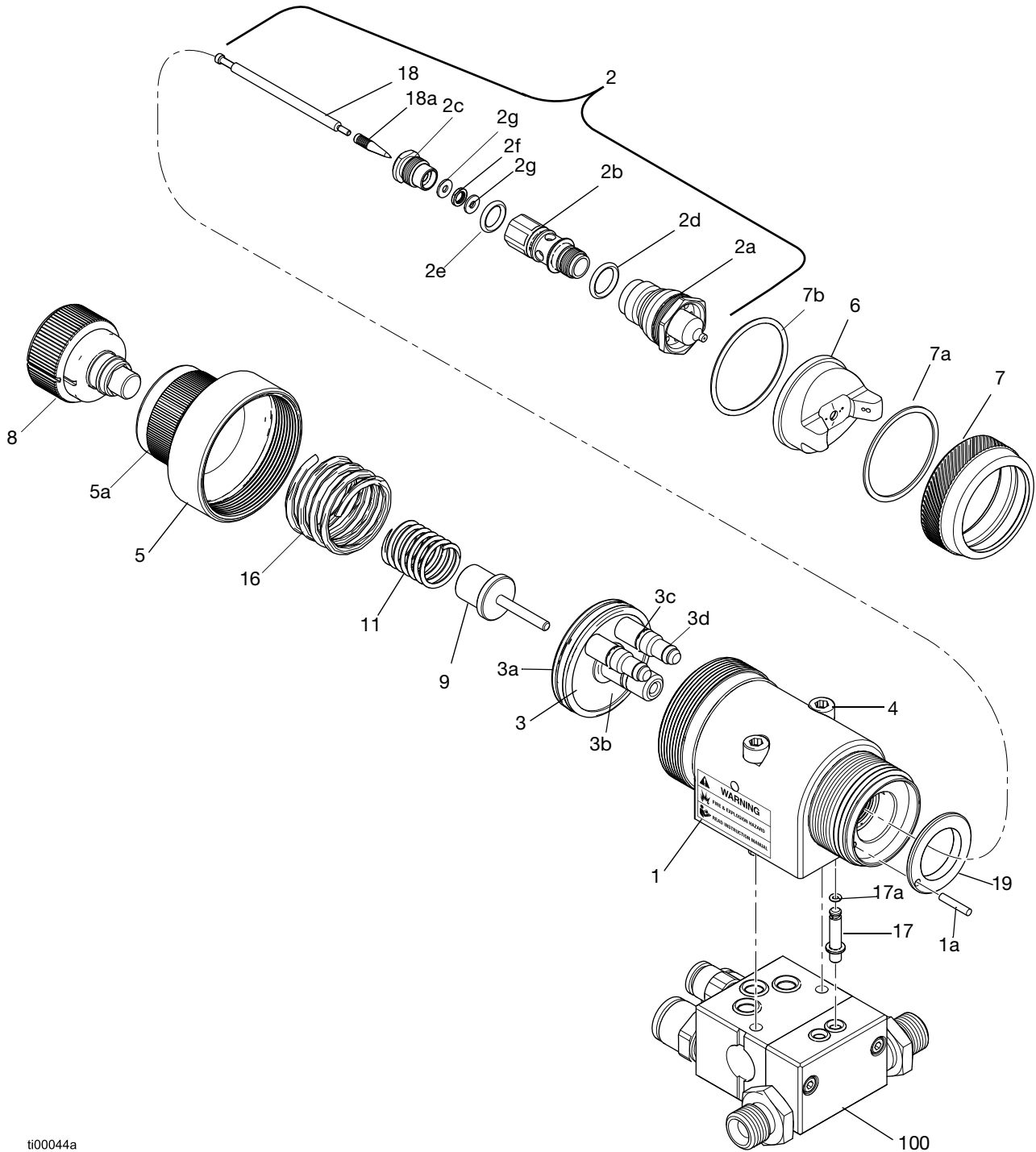

FIG. 40: True Zero Marking

Parts

Stellair Auto Air Spray Gun



ti00044a

Stellair Auto Air Spray Gun

Ref	Part	Description	Qty
1	---	Gun Body	1
1a	120471	Baffle Pin (Dowel, 3/32 in. OD x 1/2 in.)	1
2‡	❖	Fluid Cartridge Assembly (includes 2a-2g, 18 and 18a)	1
2a‡	❖	Fluid Nozzle	1
2b‡	---	Fluid Insert	1
2c‡	195222	Packing Nut; Fluid Needle	1
2d‡	111316	O-Ring Seal	1
2e‡	113137	O-Ring Seal	1
2f‡	2000513	Packing Seal	1
2g‡		Washer, UHMWPE	2
3‡	2000514	Piston Assembly (includes 3a-3e) (see FIG. 35 and FIG. 36)	1
3a‡	115066	O-Ring Seal	1
3b‡	111450	O-Ring Seal	1
3c‡	112319	O-Ring Seal	2
3d‡	111504	O-Ring Seal	2
3e‡	2000531	Piston Bearings (See FIG. 35)	2
4	15H317	M5 Manifold Mounting Screw	2
5‡	2000530	Piston Cap (Standard Models)	1
	2000516	Piston Cap for Fluid Control Knob (includes 5a and 8)	
5a‡	---	Piston Cap Setscrew (#8 x 0.25 in.)	1
6‡	❖	Air Cap	1
6a‡	24B546	Air Cap Alignment Pin (See FIG. 14)	1
7‡	25F317	Retaining Ring (7a-7b)	1
7a‡	107313	Washer	1
7b‡	15G998	O-Ring	1
8‡	---	Fluid Control Knob	1
9	2000529	Piston Spring Guide	1
11	171411	Fluid Spring	1
16	114139	Air Spring	1
17‡	2000511	Fluid Circulation Plug (includes 17a)	1
17a‡	129463	O-Ring	1
18‡	❖	Fluid Needle	1
18a‡	❖	Fluid Needle Tip	1
19	2000528	Baffle	1

Ref	Part	Description	Qty
100‡		Manifold (See Compatible Manifolds , page 39 for part details)	1

❖ Part number varies by model. See **Repair Kits**, page 32 for part numbers.

‡ Included in select models. See **Models**, page 3.

‡ Part is available in a kit. See **Kits and Accessories**, page 32.

Kits and Accessories

Repair Kits

Model	Application and Spray Type	Air Cap (6 and 6a)	Orifice Size in. (mm)	Fluid Cartridge Kit (2)	Nozzle Kit (2a)	Needle Kit (18 and 18a)	Needle Tip Kit (18a) (5 pack)
25F165	General Industry: Conventional	2000293	.055	2000503	25F226	2000510	288185
25F172	General Industry: HVLP	2000291	.055	2000503	25F226	2000510	288185
25F164	General Industry: Conventional	2000293	.042	2000502	25F225	2000509	288184
25F166	General Industry: Conventional	2000294	.070	2000504	25F227	2000510	288185
25F169	General Industry: Conventional	2000293	.055	2000503	25F226	2000510	288185
25F171	General Industry: HVLP	2000291	.042	2000502	25F225	2000509	288184
25F170	General Industry: HVLP	2000291	.030	2000501	25F224	2000507	288183
25F168	General Industry: Conventional	2000293	.042	2000502	25F225	2000509	288184
25F176	General Industry: HVLP	2000291	.055	2000503	25F226	2000510	288185
25F163	General Industry: Conventional	2000293	.030	2000501	25F224	2000507	288183
25F174	General Industry: HVLP	2000291	.030	2000501	25F224	2000507	288183
25F173	General Industry: HVLP	2000291	.070	2000504	25F227	2000510	288185
25F179	General Industry: Compliant	2000292	.055	2000503	25F226	2000510	288185
25F177	General Industry: Compliant	2000292	.030	2000501	25F224	2000507	288183
25F178	General Industry: Compliant	2000292	.042	2000502	25F225	2000509	288184
25F182	General Industry: Compliant	2000292	.042	2000502	25F225	2000509	288184
25F183	General Industry: Compliant	2000292	.055	2000503	25F226	2000510	288185
25F175	General Industry: HVLP	2000291	.042	2000502	25F225	2000509	288184
25F181	General Industry: Compliant	2000292	.030	2000501	25F224	2000507	288183
25F180	General Industry: Compliant	2000292	.070	2000504	25F227	2000510	288185
25F167	General Industry: Conventional	2000293	.030	2000501	25F224	2000507	288183
25F204	Trim: HVLP	26D898	.042	2000502	25F225	2000509	288184
25F205	Trim: HVLP	26D898	.055	2000503	25F226	2000510	288185
25F206	Trim: HVLP	26D898	.055	2000503	25F226	2000510	288185

✓ Adhesive air cap can be purchased without alignment pin (6a) and is marked as manufacturing part 289051

✘ Air brush air caps do not include 6a

Model	Application and Spray Type	Air Cap (6 and 6a)	Orifice Size in. (mm)	Fluid Cartridge Kit (2)	Nozzle Kit (2a)	Needle Kit (18 and 18a)	Needle Tip Kit (18a) (5 pack)
25F207	Trim: HVLP	26D898	.055	2000503	25F226	2000510	288185
25F208	Air Brush: Conventional	24D705✱	.042	2000502	25F225	2000509	288184
25F209	Air Brush: Conventional	24D705✱	.042	2000502	25F225	2000509	288184
25F210	Adhesive: Conventional	2000301✓	0.051	2000505	25F233	2000510	288185
25F211	Adhesive: Conventional	2000301✓	0.070	2000506	25F234	2000510	288185
25F212	General Industry: Conventional	2000293	.055	2000503	25F226	2000510	288185
25F213	General Industry: Conventional	2000293	.055	2000503	25F226	2000510	288185
25F214	General Industry: HVLP	2000291	.055	2000503	25F226	2000510	288185
25F215	General Industry: HVLP	2000291	.055	2000503	25F226	2000510	288185
25F216	General Industry: Compliant	2000292	.055	2000503	25F226	2000510	288185
25F217	General Industry: Compliant	2000292	.055	2000503	25F226	2000510	288185
25F218	General Industry: Conventional	2000293	.055	2000503	25F226	2000510	288185
25F219	General Industry: Conventional	2000293	.055	2000503	25F226	2000510	288185

✓ Adhesive air cap can be purchased without alignment pin (6a) and is marked as manufacturing part 289051

✱ Air brush air caps do not include 6a

Kit 289791: Air Cap Seals

Ref	Part	Description	Qty
7a‡	107313	Washer	5
7b‡	15G998	O-Ring	5

Kit 2000512: Fluid Cartridge Seals

Ref	Part	Description	Qty
2d	111316	O-Ring Seal	1
2e	113137	O-Ring Seal	1

Kit 2000513: Fluid Cartridge Packings

Ref	Part	Description	Qty
2f	16A698	Packing Seal	1
2g	16C295	Washer, UHMWPE	2

Kit 25F317: Retaining Ring Assembly

Ref	Description	Qty
7	Retaining Ring	1
7a	Washer	1
7b	O-Ring	1

Kit 24B546: Air Cap Alignment Pins

Ref	Description	Qty
6A	Air Cap Alignment Pin	10

Kit 2000514: Piston Assembly

Ref	Part	Description	Qty
3	2000514	Piston	1
3a	115066	O-Ring Seal	1
3b	111450	O-Ring Seal	1
3c	112319	O-Ring Seal	2
3d	111504	O-Ring Seal	2
3e	2000531	Piston Bearings	2

Kit 2000531: Piston Bearings

Ref	Description	Qty
3e	Piston Bearings	10

Kit 2000515: Piston Seals

Ref	Part	Description	Qty
3a	115066	O-Ring Seal	1
3b	111450	O-Ring Seal	1
3c	112319	O-Ring Seal	2
3d	111504	O-Ring Seal	2

Kit 2000516: Fluid Control Knob Assembly

Convert a standard automatic gun to add a fluid control knob.

Ref	Description	Qty
5	Piston Cap with Setscrew	1
8	Fluid Control Knob	1

Kit 2000517: Manifold Seals

Ref	Part	Description	Qty
107	111450	O-Ring Air Seal	3
108	111508	O-Ring Fluid Seal	2

Kit 2000511: Circulation Plug Kit

Ref	Description	Qty
17	Circulation Plug	1
17a	O-Ring	1

Accessories

Alignment Tool: 2000481

Alignment Tool Features

- Gauge to quickly set spray pattern angles. See **Angled Spray Pattern**, page 13.
- Path guide to help visualize the spray center point and the distance between the gun and the workpiece. See **Position the Spray Gun and Workpiece**, page 14.

26D220: Dump Valve

Fluid inlet and outlet ports are 1/4 in. npt(f), and 303 SST wetted parts.

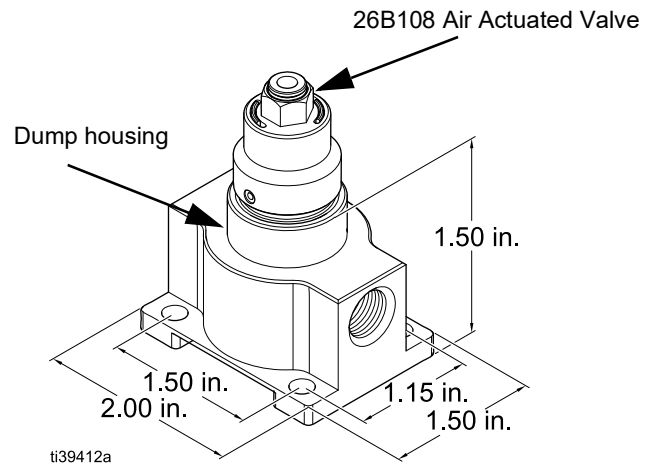

Fluid Line Accessories

Part	Description	Qty
24B707*	In-line Fluid Filter	1
166846	Fluid Fitting, SST, 1/4 npsm(m) x 1/4 npt(m), 7250 PSI (50 MPa, 500 bar) maximum pressure	1
24C375**	1:1 Ratio Air Operated Fluid Regulator	1
24E471**	1:2 Ratio Air Operated Fluid Regulator	1
24E472**	1:3 Ratio Air Operated Fluid Regulator	1

* See manual 406814.

** See manual 3A0427.

Fluid Hoses

Part	Description	Maximum Working Pressure	Length	Fitting Options (1/4 NPSM)			
				No Spring Guard	Spring Guard	3 Piece Coupler	2 Piece Coupler
061132	1/4 in. ID nylon fluid hose	225 psi (16 bar)	500 ft (152 m)	205447	111913	---	---
061205	1/4 in. ID nylon braided hose with neoprene cover	500 psi (30 bar)	500 ft (152 m)	---	---	104415	16A989

HVLP Pressure Verification Kit

Part	Description	Compatible Air Cap
2000518	HVLP General Industry	2000291
2000523	Trim	26D898

Light-Weight Oil

Recommended oil for fluid seals and wear areas.

Part	Description
111265	Sanitary, non-silicone lubricant: 4 oz (113g)

Installation and Repair Tools

Part	Description
222955	Anti-Seize Lubricant
289794	Gun Tool multi-wrench

Cleaning Accessories

Part	Description
15C161	Ultimate Gun Cleaning Kit: brushes and tools for gun maintenance.
249598	Unclogging Needle: picks for unclogging gun nozzle
101892	Brush for cleaning the gun

Fluid Cartridge and Fluid Nozzle Information

The fluid flow and pattern width depend on the size of the nozzle, the fluid viscosity, and the fluid pressure.

- For low flow rates or light viscosity fluid, select the smaller nozzle sizes.

Use a fluid nozzle that will achieve the required flow with the needle fully triggered at a fluid pressure of 5–20 psi (0.035–0.14 MPa, 0.35–1.4 bar).

- For high flow rates or high viscosity fluid, select the larger nozzle sizes.

Application‡	Orifice Size in. (mm)	Fluid Cartridge Kit (2)	Nozzle Kit (2a)	Recommended for material viscosity	Typical flow rate oz/min (l/min)	Construction	Spray Technology and Air Cap Compatibility
General Industry Air Brush Trim	0.030 (0.8)	2000501	25F224	light 5-15 centipoise	4-10 (0.12-0.30)	SST Nozzle, PEEK Tip	Conventional Air Caps: 2000293 and 24D705 HVLP Air Caps: 2000291 and 26D898 Compliant Air Caps: 2000292
	0.042 (1.1)	2000502	25F225	light-medium 15-30 centipoise	8-14 (0.24-0.42)	SST Nozzle, PEEK Tip	
	0.055 (1.4)	2000503	25F226	medium 30-70 centipoise	12-18 (0.36-0.54)	SST Nozzle, PEEK Tip	
General Industry	0.070 (1.8)	2000504	25F227	medium-heavy 70-100 centipoise	16-20 (0.48-0.60)	SST Nozzle, PEEK Tip	Conventional Air Caps: 2000294
Adhesive	0.051 (1.3)	2000505	25F233	medium 30-70 centipoise	12-18 (0.36-0.54)	SST Nozzle, PEEK Tip	Conventional Adhesive Air Caps: 2000301 ✓
	0.07 (1.8)	2000506	25F234	medium-heavy 70-100 centipoise	16-20 (0.48-0.60)	SST Nozzle, PEEK Tip	

‡ See **Applications**, page 2.

✓ Air cap marked with manufacturing part 289051

Air Cap and Air Flow

Example: Air Cap 2000293

Add the air consumption values shown for the atomizing air and fan air pressures to get the total air consumption.

Atomizing Air SCFM at 20 psi		Fan Air SCFM at 30 psi		Total Air Consumption
2.8	+	6	=	8.8

Application	Air Cap	Atomizing Air		Fan Air	
		Manifold Inlet Pressure psi (MPa, bar)	Air Flow SCFM	Manifold Inlet Pressure psi (MPa, bar)	Air Flow SCFM
General Industry: Conventional	2000293	10	2.3	10	5.5
		20	2.8	20	5.7
		30	3.0	30	6.0
		40	3.4	40	6.7
		50	3.9	50	7.3
	2000294	10	6.4	10	4.6
		20	7.3	20	5.3
		30	8.3	30	6.0
		40	8.7	40	6.2
		50	9.2	50	6.4
General Industry: HVLP	2000291	10	3.9	10	8.3
		20	5.3	20	9.4
		20*	5.3*	24*	9.6*
		30	5.7	30	10.1
		40	6.0	40	11.0
		50	6.2	50	11.9
Trim: HVLP	26D898	10	2.8	10	4.6
		14*	3.0*	12*	4.6*
		20	3.4	20	5.5
		30	3.9	30	6.0
		40	4.6	40	6.4
		50	4.8	50	6.9
General Industry: Compliant	2000292	10	3.0	10	5.5
		14*	3.0*	15*	5.5*
		20	3.4	20	6.0
		30	3.9	30	6.4
		40	4.4	40	6.9
		50	4.8	50	7.3

* Maximum HVLP/Compliant inlet manifold pressure.

✓ Air cap marked with manufacturing part 289051

Application	Air Cap	Atomizing Air		Fan Air	
		Manifold Inlet Pressure psi (MPa, bar)	Air Flow SCFM	Manifold Inlet Pressure psi (MPa, bar)	Air Flow SCFM
Adhesive	2000301 ✓	10	2.5	10	6.0
		14*	3.4*	17*	6.4*
		20	3.2	20	6.9
		30	3.7	30	7.8
		40	4.1	40	8.3
		50	4.6	50	9.2
Air Brush	24D705	10	1.4	10	0.0
		20	1.6	20	1.1
		30	1.8	30	1.6
		40	2.1	40	1.8
		50	2.1	50	1.8

* Maximum HVLP/Compliant inlet manifold pressure.

✓ Air cap marked with manufacturing part 289051

Compatible Manifolds

Manifolds with Inch Threads

Ref	Part	Description	Qty
101	—	Manifold Body	1
102	114342	Fluid Connector Elbow Fitting: 1/4 - 18 npt	2
	2001082*	Fluid Connector	2
102a	120353 *	O-ring Fluid Connector	2
103	101970	Pipe plug (see FIG. 4, page 8)	1
104	120388	Air Tube Fitting: 1/4 in. OD tube x 1/8 npt(m)	1
105	120389	Air Tube Fitting: 3/8 in. OD tube x 1/4 npt	2
	120389*		1
106	114246	Set Screw: 5/16; 0.437 in. long	1
107‡	111450	O-Ring Air Seal	3
108‡	111508	O-Ring Fluid Seal	2
109	2001083*	Fan Valve Assembly	1

★ 25F155 model

✱ 2000230 model

✱ 2000226 model

‡ Part available in a kit. See **Repair Kits**, page 32.

Manifold Connections

Fluid Connection	1/4-18 npt(m)* 1/4-18 npsm(m)**
Atomizing Air Inlet (ATOM)	3/8 in. OD tube
Fan Air Inlet (FAN)†	3/8 in. OD tube†
Cylinder Air Inlet (CYL)	1/4 in. OD tube

* 25F155 and 2000226 models

** 2000230 model

† Manifold 2000226 has a single air inlet for atomizing and fan air

Side Fluid Inlet Manifold (25F155★)

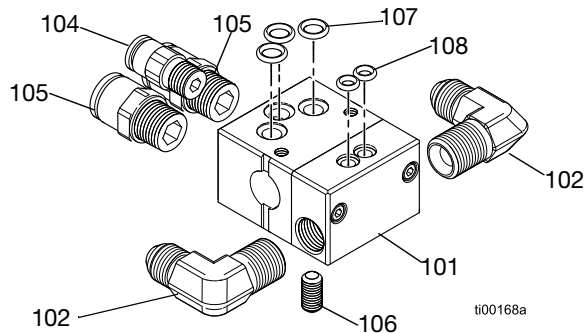

Rear Fluid Inlet Manifold (2000230✱)

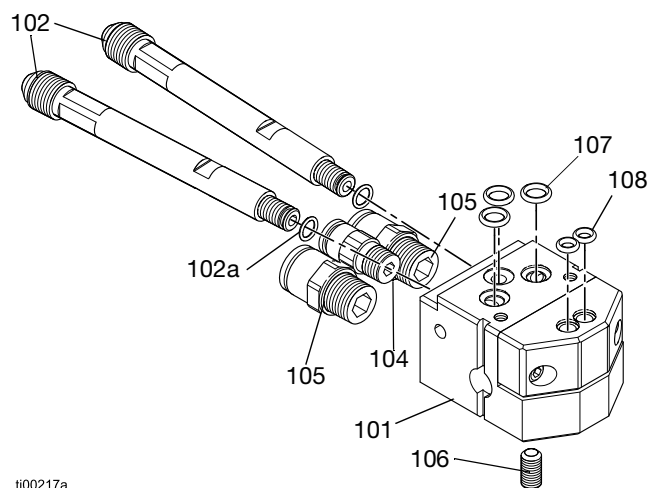

Side Fluid Inlet Manifold with Fan Adjustment Valve (2000226✱)

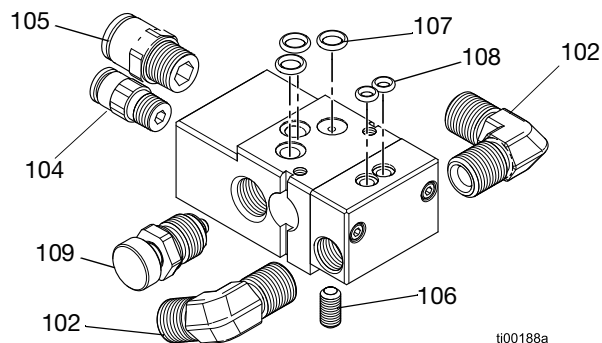

Manifolds with Metric Threads

Ref	Part	Description	Qty
101	—	Manifold Body	1
102	114247✳	Fluid Connector Male Elbow Fitting: #5JIC x 1/4-18 npt	2
	2000235✳	Fluid Connector	2
102a	120353✳	O-ring Fluid Connector	2
103	101970	Pipe plug (see FIG. 4, page 8)	1
104	120538	Air Tube Fitting: 6 mm OD tube x 1/8 npt(m)	1
105	120537	Air Tube Fitting: 8 mm OD tube x 1/4 npt	2
	15D916◆	Air Tube Fitting: 4 mm OD tube x 1/4 npt (shipped loose)	2
106	114246	Set Screw: 5/16; 0.437 in. long	1
107‡	111450	O-Ring Air Seal	3
108‡	111508	O-Ring Fluid Seal	2

✳ 25F315 model

✳ 2000231 model

‡ Part available in a kit. See **Repair Kits**, page 32.

Manifold Connections

Fluid Connection	#5 JIC
Atomizing Air Inlet (ATOM)	8 mm OD tube
Fan Air Inlet (FAN)◆	8 mm OD tube
Cylinder Air Inlet (CYL)	6 mm OD tube

◆ 25F315 and 2000231 ship with alternate atomizing/fan air fitting with a 4 mm OD tube connection

Side Fluid Inlet Manifold (25F315✳)

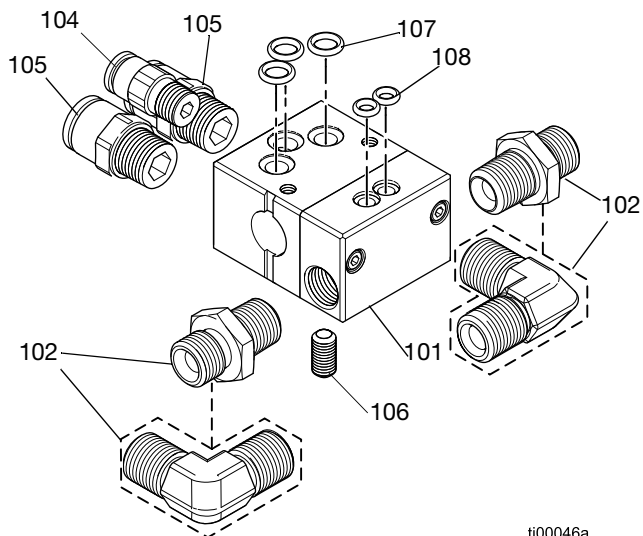

Rear Fluid Inlet Manifold (2000231✳)

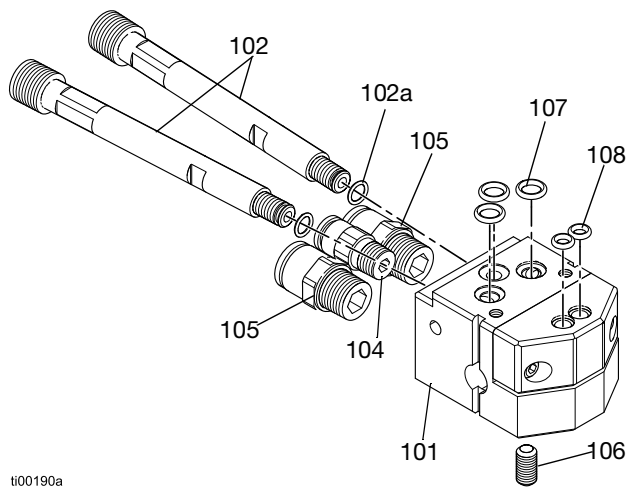

Mounting Hole Layout and Dimensions

Gun Dimensions

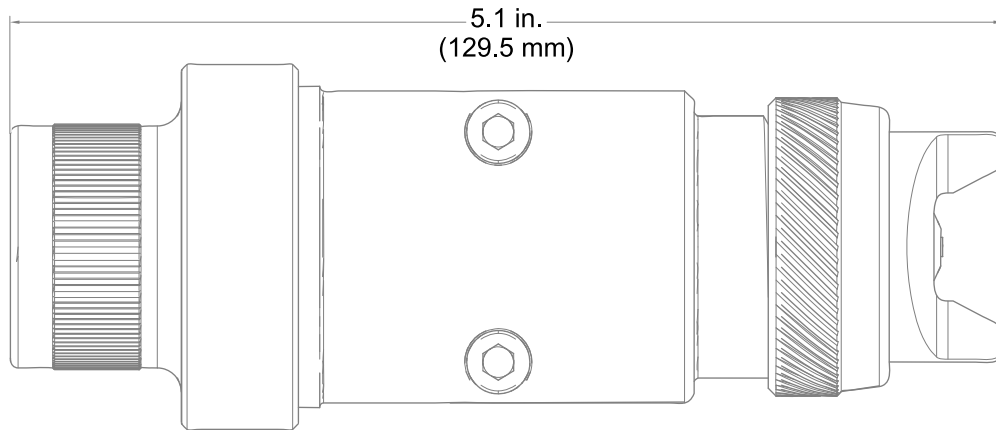
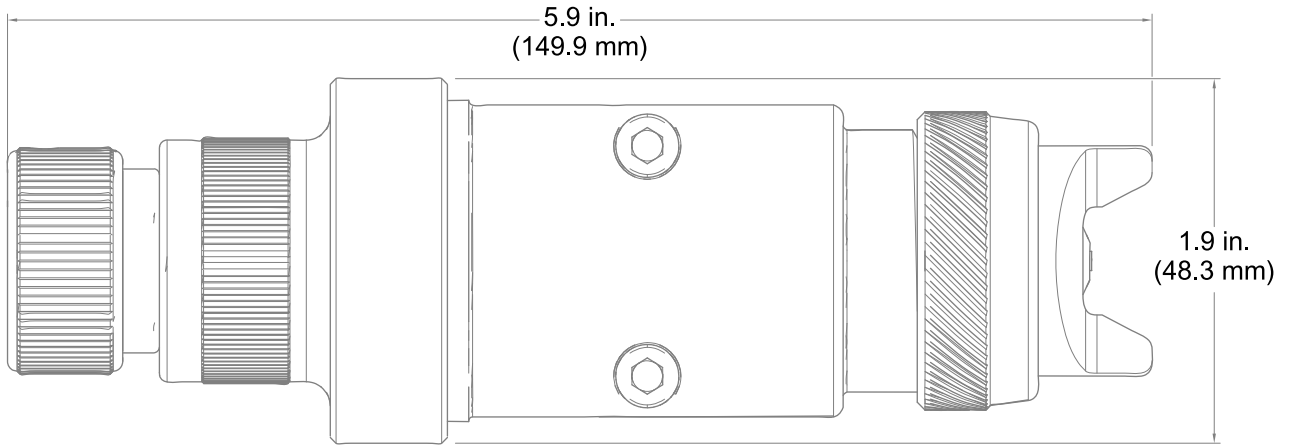

ti00288a

Manifolds with Side Fluid Inlet

Models 25F315 and 25F155

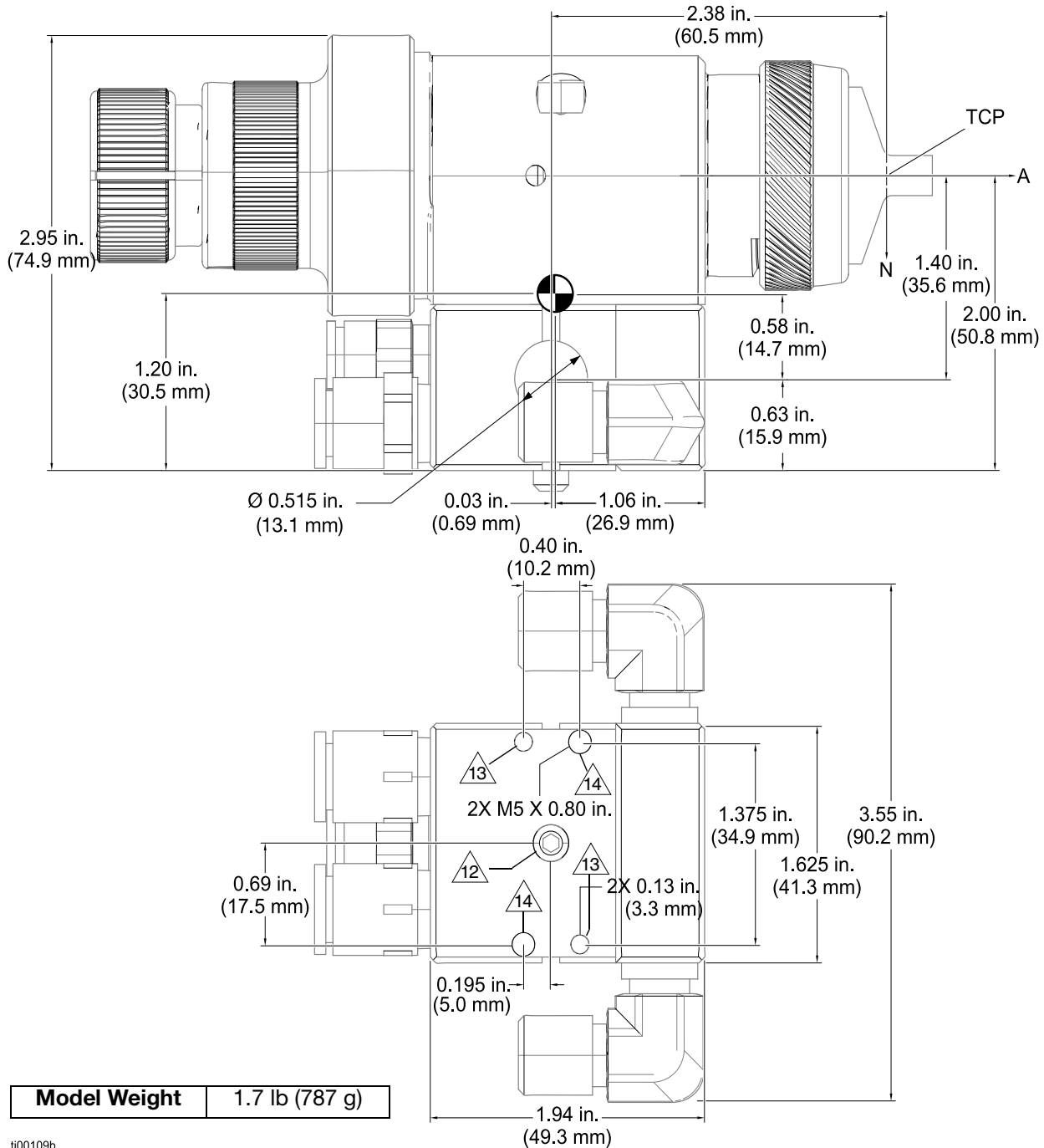

ti00109b

12 Remove set screw when using Stationary Support Installation.

13 Alignment Pin Holes
0.128 diameter x 0.31 in. (7.8 mm) deep holes

14 Mounting Screw Holes
M5 x 0.8 x 0.25 in. (6.3 mm)
Use a screw long enough to engage the mounting screw holes to a 0.25 in. (6.3 mm) depth.

Manifold with Side Fluid Inlet and Fan Adjustment Valve

Model 2000226

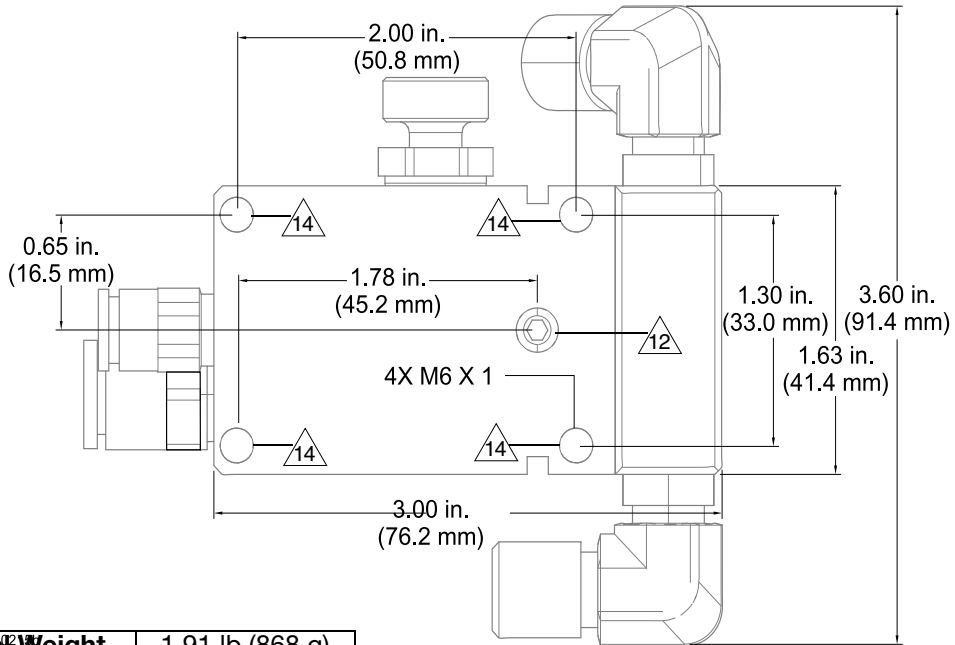
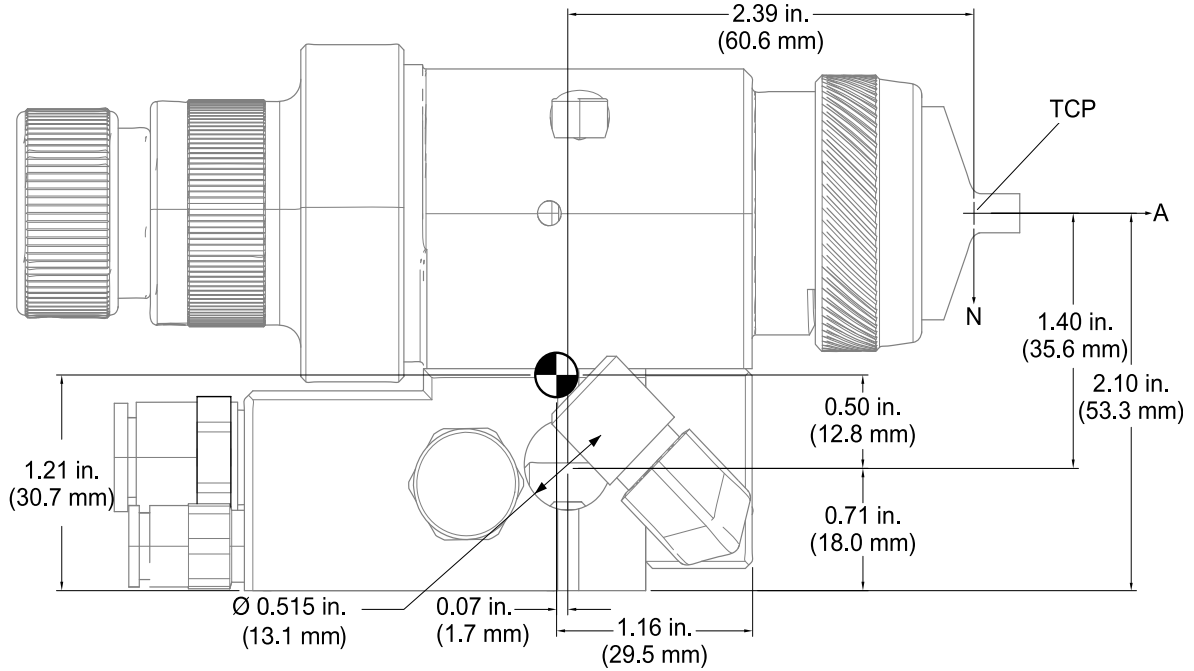

Model Weight	1.91 lb (868 g)
---------------------	-----------------

 Remove set screw when using Stationary Support Installation.

 **Mounting Screw Holes**
M6 x 1.0 x 0.34 in. (8.6 mm)
Use a screw long enough to engage the mounting screw holes to a 0.34 in. (8.6 mm).

Manifolds with Rear Inlet

Models 2000230 and 2000231

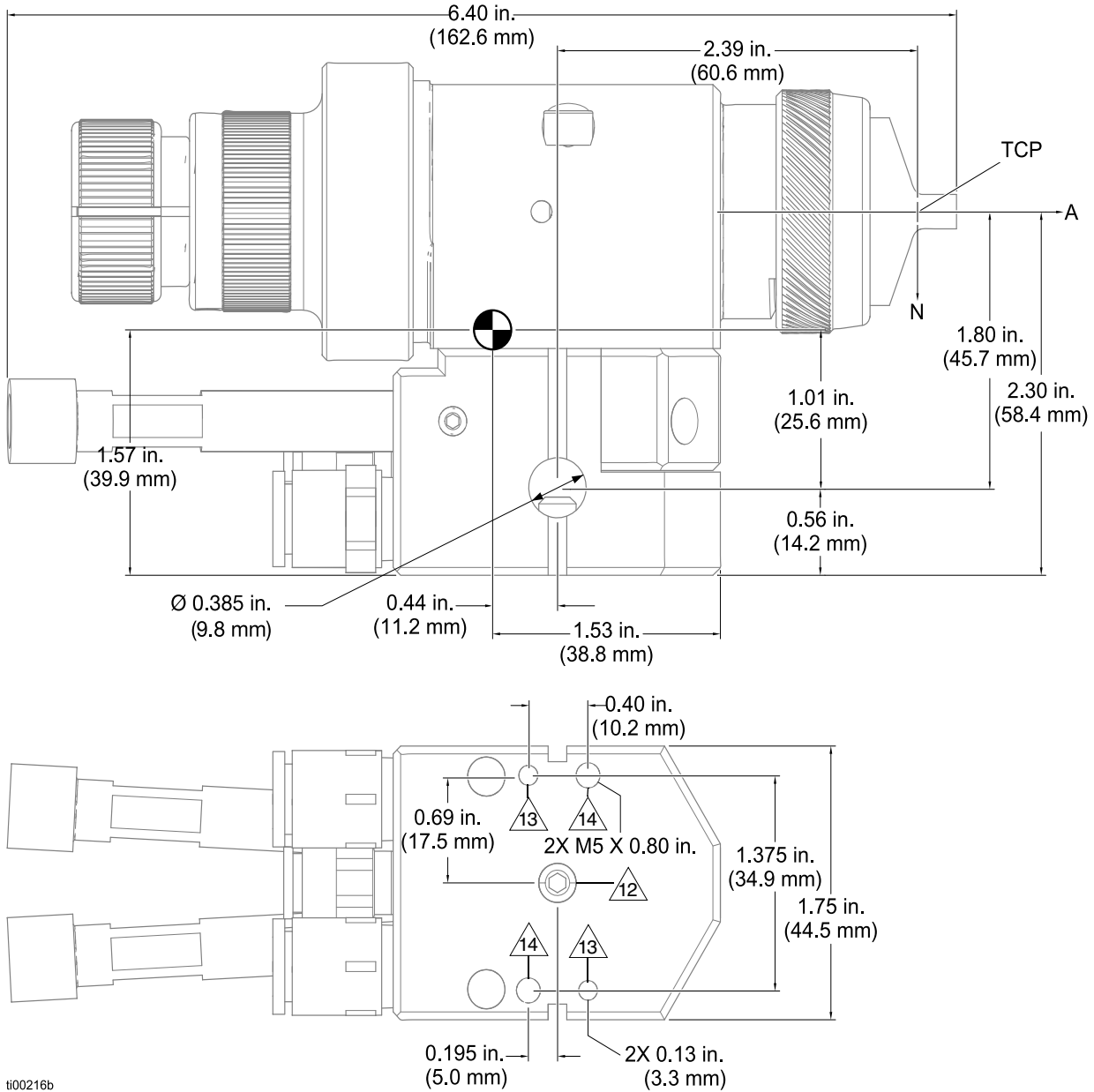

ti00216b

Model Weight	1.93 lb (875 g)
---------------------	-----------------

12 Remove set screw when using Stationary Support Installation.

13 Alignment Pin Holes
0.126 diameter x 0.31 in. (7.8 mm) deep holes

14 Mounting Screw Holes
M5 x 0.8 x 0.25 in. (6.3 mm)
Use a screw long enough to engage the mounting screw holes to a 0.25 in. (6.3 mm) depth.

Gun Mounting Kit 24C208

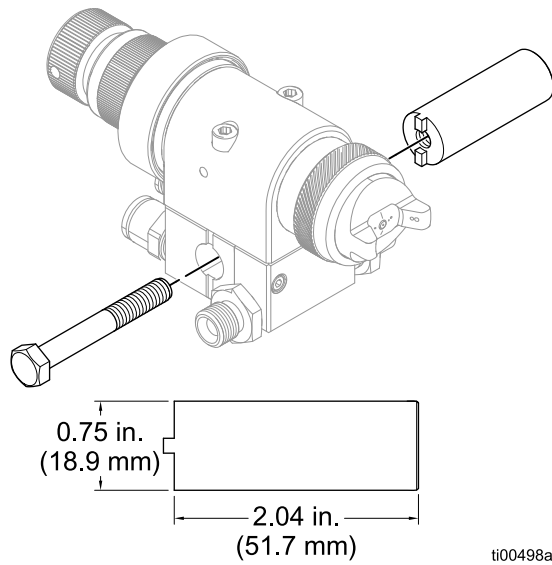

Retrofit Adapter Plate 288197

For use with manifold models 25F315, 25F155, 2000230, and 2000231.

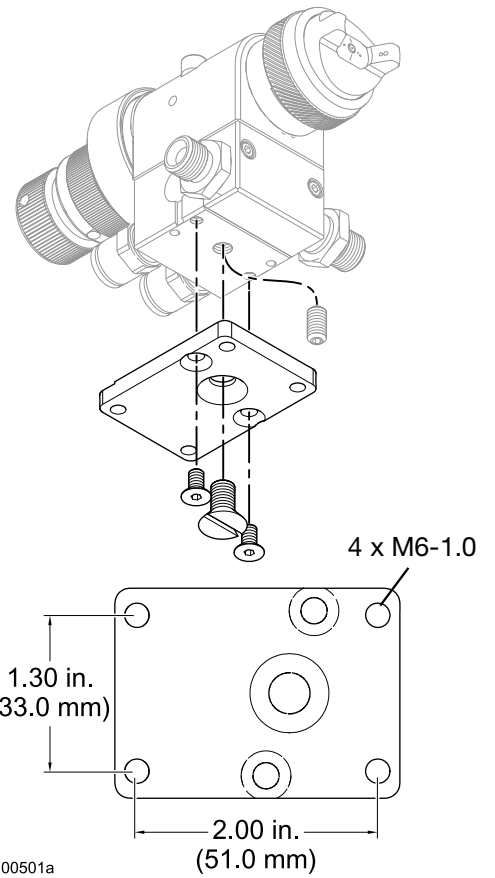

Gun Mounting Kit 24B609

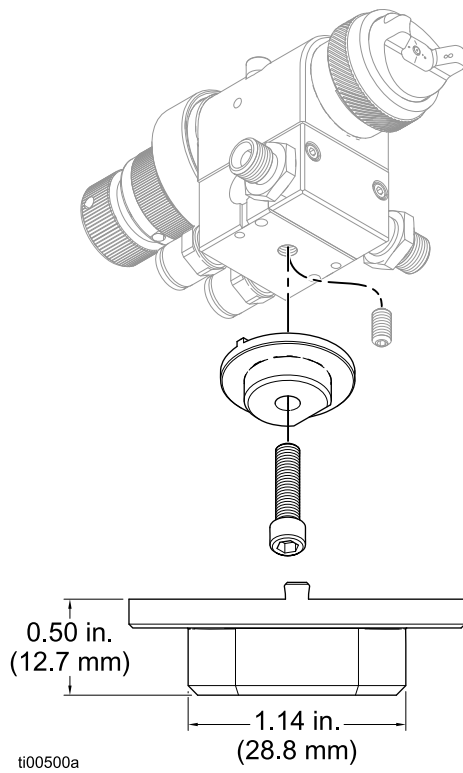

Single Gun Mounting Bracket 24Y515

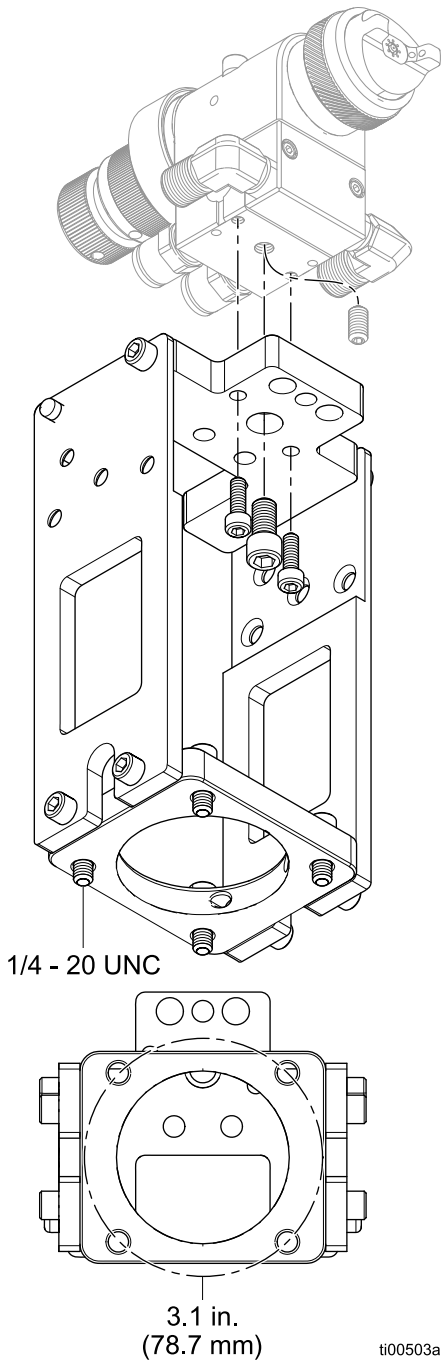

Dual Gun Mounting Bracket 25A844

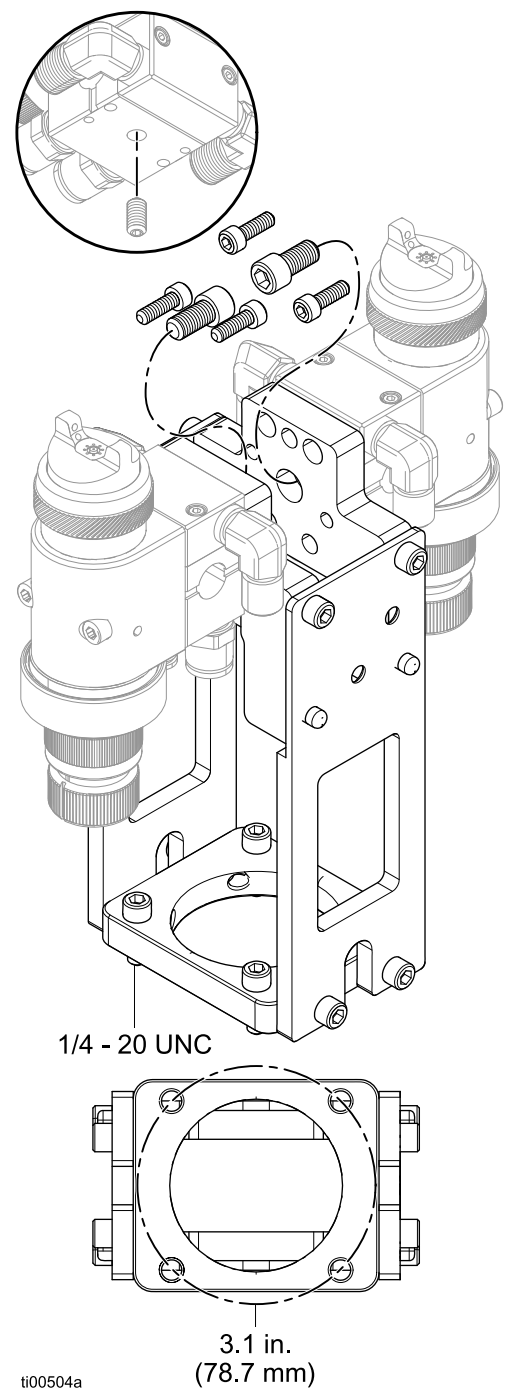

Robot Adapter Plates

Table 1. Robot Adapter Plates

Adapter Plate	Robot	Bolt Circle	Mounting Screws	Locating Pin Circle	Locating Pins
24Y128	MOTOMAN EPX1250	27.5 mm (1.083 in)	4X M5 x 0.8	27.5 mm (1.083 in)	5 mm
24Y129	MOTOMAN PX1450	32 mm (1.260 in)	8X M6 x 1.0	---	---
	MOTOMAN EPX2850, Three-roll type				
24Y634	MOTOMAN EPX2050	102 mm (4.02 in)	6X M6 x 1.0	102 mm (4.02 in)	2X 4 mm
	ABB IRB 580				
	ABB IRB 5400				
24Y650	MOTOMAN EPX2700	102 mm (4.02 in)	6X M6 x 1.0	102 mm (4.02 in)	2X 5 mm
	MOTOMAN EPX2800				
	MOTOMAN EPX2900				
	KAWASAKI KE610L				
	KAWASAKI KJ264				
	KAWASAKI KJ314				
24Y172	ABB IRB 540	36 mm (1.42 in)	3X M5	---	---
24Y173	ABB IRB 1400	40 mm (1.58 in)	4X M6	---	---
24Y768	FANUC PAINT MATE 200iA	31.5 mm (1.24 in)	4X M5	31.5 mm (1.24 in)	1X 5 mm
	FANUC PAINT MATE 200iA/5L				
24Y769	FANUC P-250	100 mm (3.94 in)	6X M5	100 mm (3.94 in)	1X 5 mm

Mounting Hole Layout and Dimensions

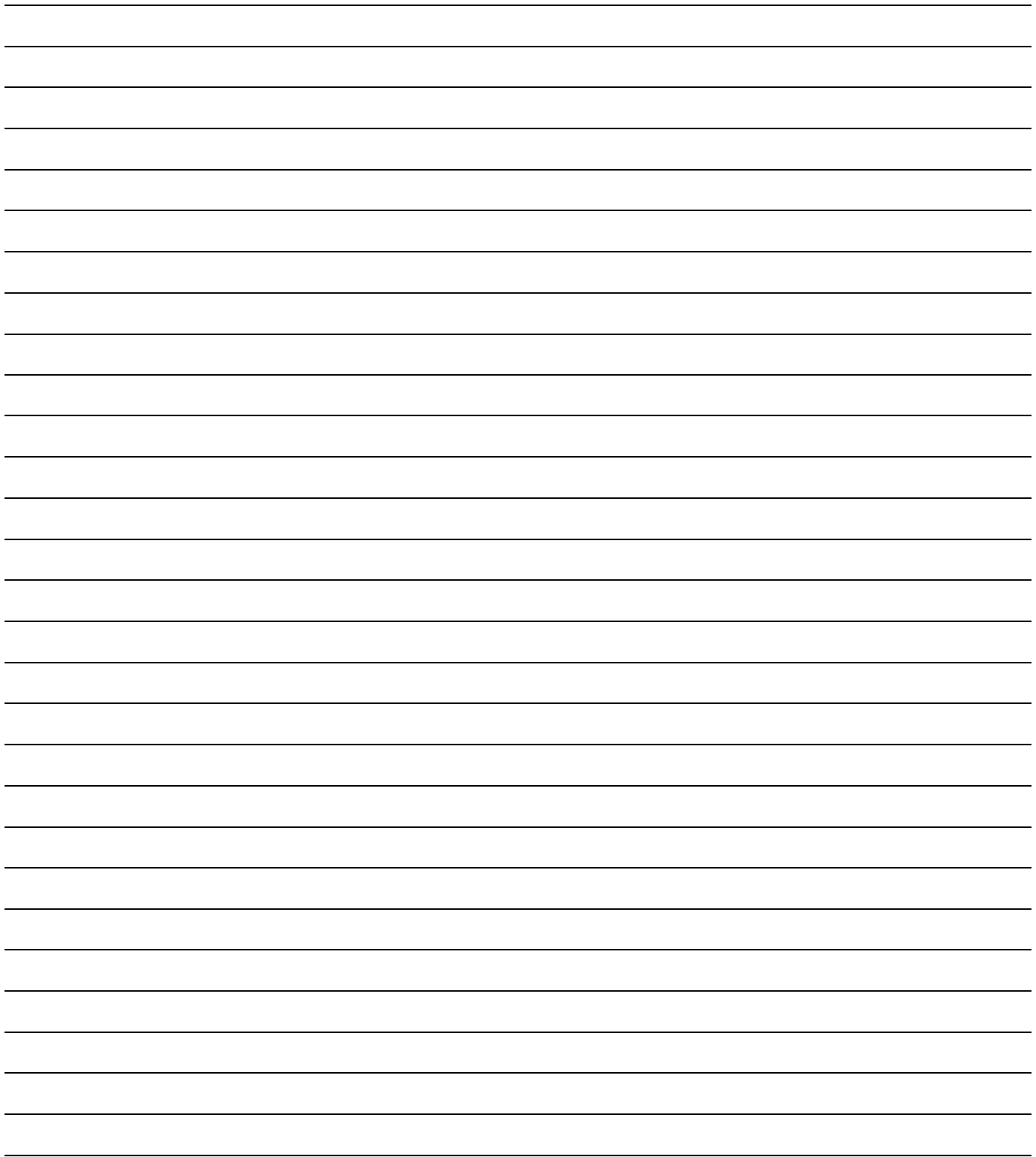

Technical Specifications

Stellair Auto Air Spray Guns	US	Metric
Maximum working fluid pressure	300 psi	2.1 MPa, 21 bar
Maximum working air pressure	100 psi	0.7 MPa, 7 bar
Maximum fluid temperature	120°F	49°C
Minimum Air Cylinder Actuation Pressure	50 psi	0.34 MPa, 3.4 bar
Materials of Construction	Stainless Steel, Ultra High Molecular Weight Polyethylene, Chemically Resistant Fluoroelastomer, Engineered Plastic, PTFE, Aluminum	
Gun and Manifold Models Weight	1.5 lb	697 g
Gun Model Weight	1 lb	431 g

Triggering Speed

These values apply to a new gun with a 12 ft (3.6 m), 1/4 in. (6.3 mm) OD cylinder air line and a 0.03 in. (0.8 mm) nozzle. These values will vary slightly with use and with variations in equipment.

Cylinder Air Pressure psi (MPa, bar)	Fluid Pressure psi (MPa, bar)	msec to fully open	msec to fully close
50 (0.35, 3.5)	50 (0.35, 3.5)	71	66

Sound Data

Conventional	
Measured at 44 psi (0.30 MPa, 3.0 bar) atomizing air and 47 psi (0.32 MPa, 3.2 bar) fan air pressure	
Sound Power	94 LwA
Sound Pressure	80 dBa
HVLP	
Measured at 17 psi (0.12 MPa, 1.2 bar) atomizing air and 29 psi (0.20 MPa, 2.0 bar) fan air pressure	
Sound Power	92 LwA
Sound Pressure	79 dBa
Compliant	
Measured at 29 psi (0.20 MPa, 2.0 bar) atomizing air and 33 psi (0.23 MPa, 2.3 bar) fan air pressure	
Sound Power	89 LwA
Sound Pressure	76 dBa
<i>Sound power measured per ISO 9614-2.</i>	

California Proposition 65

CALIFORNIA RESIDENTS

 **WARNING:** Cancer and reproductive harm – www.P65warnings.ca.gov.

Graco Standard Warranty

Graco warrants all equipment referenced in this document which is manufactured by Graco and bearing its name to be free from defects in material and workmanship on the date of sale to the original purchaser for use. With the exception of any special, extended, or limited warranty published by Graco, Graco will, for a period of twelve months from the date of sale, repair or replace any part of the equipment determined by Graco to be defective. This warranty applies only when the equipment is installed, operated and maintained in accordance with Graco's written recommendations.

This warranty does not cover, and Graco shall not be liable for general wear and tear, or any malfunction, damage or wear caused by faulty installation, misapplication, abrasion, corrosion, inadequate or improper maintenance, negligence, accident, tampering, or substitution of non-Graco component parts. Nor shall Graco be liable for malfunction, damage or wear caused by the incompatibility of Graco equipment with structures, accessories, equipment or materials not supplied by Graco, or the improper design, manufacture, installation, operation or maintenance of structures, accessories, equipment or materials not supplied by Graco.

This warranty is conditioned upon the prepaid return of the equipment claimed to be defective to an authorized Graco distributor for verification of the claimed defect. If the claimed defect is verified, Graco will repair or replace free of charge any defective parts. The equipment will be returned to the original purchaser transportation prepaid. If inspection of the equipment does not disclose any defect in material or workmanship, repairs will be made at a reasonable charge, which charges may include the costs of parts, labor, and transportation.

THIS WARRANTY IS EXCLUSIVE, AND IS IN LIEU OF ANY OTHER WARRANTIES, EXPRESS OR IMPLIED, INCLUDING BUT NOT LIMITED TO WARRANTY OF MERCHANTABILITY OR WARRANTY OF FITNESS FOR A PARTICULAR PURPOSE.

Graco's sole obligation and buyer's sole remedy for any breach of warranty shall be as set forth above. The buyer agrees that no other remedy (including, but not limited to, incidental or consequential damages for lost profits, lost sales, injury to person or property, or any other incidental or consequential loss) shall be available. Any action for breach of warranty must be brought within two (2) years of the date of sale.

GRACO MAKES NO WARRANTY, AND DISCLAIMS ALL IMPLIED WARRANTIES OF MERCHANTABILITY AND FITNESS FOR A PARTICULAR PURPOSE, IN CONNECTION WITH ACCESSORIES, EQUIPMENT, MATERIALS OR COMPONENTS SOLD BUT NOT MANUFACTURED BY GRACO. These items sold, but not manufactured by Graco (such as electric motors, switches, hose, etc.), are subject to the warranty, if any, of their manufacturer. Graco will provide purchaser with reasonable assistance in making any claim for breach of these warranties.

In no event will Graco be liable for indirect, incidental, special or consequential damages resulting from Graco supplying equipment hereunder, or the furnishing, performance, or use of any products or other goods sold hereto, whether due to a breach of contract, breach of warranty, the negligence of Graco, or otherwise.

FOR GRACO CANADA CUSTOMERS

The Parties acknowledge that they have required that the present document, as well as all documents, notices and legal proceedings entered into, given or instituted pursuant hereto or relating directly or indirectly hereto, be drawn up in English. Les parties reconnaissent avoir convenu que la rédaction du présente document sera en Anglais, ainsi que tous documents, avis et procédures judiciaires exécutés, donnés ou intentés, à la suite de ou en rapport, directement ou indirectement, avec les procédures concernées.

Graco Information

For the latest information about Graco products, visit www.graco.com.

For patent information, see www.graco.com/patents.

TO PLACE AN ORDER, contact your Graco distributor or call to identify the nearest distributor.

Phone: 612-623-6921 **or Toll Free:** 1-800-328-0211, **Fax:** 612-378-3505

*All written and visual data contained in this document reflects the latest product information available at the time of publication.
Graco reserves the right to make changes at any time without notice.*

Original instructions. This manual contains English. MM 407194

Graco Headquarters: Minneapolis

International Offices: Belgium, China, Japan, Korea

GRACO INC. AND SUBSIDIARIES • P.O. BOX 1441 • MINNEAPOLIS MN 55440-1441 • USA
Copyright 2023, Graco Inc. All Graco manufacturing locations are registered to ISO 9001.

www.graco.com
Revision D, June 2023