



# **AIRLESS PAINT LINE STRIPER SERVICE/OPERATION MANUAL**



**SURE STRIPE  
4550 & 6050**

# TABLE OF CONTENTS

SECTION	FIGURE
Introduction.....	1
Safety Warnings .....	2
Setting Up.....	5
Flushing .....	5
How to Flush .....	6
Starting Up .....	7
Pressure Relief Procedure .....	9
Line Striping Operation.....	10
Airless Spray Gun Operation.....	11
Airless Spray Gun .....	12
Airless Spray Troubleshooting.....	13
Rev Tips .....	14
Regular Maintenance .....	15
Field Troubleshooting .....	15
Servicing the Fluid Pump .....	16
Servicing the Inlet Valve .....	17
Servicing the Outlet Valve .....	17
Packing Replacement Procedures .....	18
Paint System Assembly.....	20
Prime Valve .....	21
Manifold Filter.....	21
Replacement of Electrical Control Board .....	22
Pressure Calibration on the Control Board....	22
Clutch Troubleshooting.....	23
Clutch Replacement.....	23
Clutch Assembly.....	25
Engine Assembly.....	25
Power Unit Assembly .....	26
First Gun Assembly .....	27
Second Gun Assembly .....	27
Ball Valve.....	27
Gun Holder Assembly.....	28
Swivel Wheel Assembly - 4550 .....	29
Frame Assembly - 4550 .....	30
Swivel Lock Assembly - 6050.....	31
Swivel Wheel Assembly - 6050 .....	31
Frame Assembly - 6050 .....	32
Suction Assembly .....	33
Striping Accessories .....	33
Airlessco Accessories.....	34
1 Filling the Packing Nut/Wet Cup.....	5
2. Spray Tip .....	6
3. Prime Valve .....	6
4. Pressure Control Knob .....	6
5. Choke, Fuel, Throttle.....	6
6. Static Discharge .....	6
7. Spray Gun .....	11
8. Gun Safety Latch.....	11
9. Major Gun Components .....	11
10. Spray Tip .....	11
11. Airless Spray Gun .....	12
12. Oil and Lubrication .....	14
13. Fluid Pump .....	16
14. Fluid Pump Connection .....	16
15. Fluid Pump Connection .....	16
16. Fluid Pump Connection .....	16
17. Fluid Pump Connection .....	16
18. Fluid Pump Connection .....	16
19. Inlet Valve .....	17
20. Outlet Valve .....	17
21. V-Packing .....	19
22. V-Packing Cutaway .....	19
23. Paint System .....	20
24. Prime Valve .....	21
25. Manifold Filter.....	21
26. Control Board .....	22
27. Belt Tensioning .....	24
28. Clutch Assembly.....	25
29. Engine Assembly.....	25
30. Power Unit Assembly .....	26
31. First Gun Assembly .....	27
32. Second Gun Assembly .....	27
33. Ball Valve.....	27
34. Gun Holder Assembly.....	28
35. Swivel Wheel Assembly - 4550 .....	29
36. Frame Assembly - 4550 .....	30
37. Swivel Lock Assembly - 6050.....	31
38. Swivel Wheel Assembly - 6050 .....	31
39. Frame Assembly - 6050 .....	32
40. Suction Assembly .....	33



# INTRODUCTION



The Model 4550 & 6050 are gasoline powered, SL "Slow Stroker" piston pump equipped, airless line stripers. They have been designed to have the reliability and versatility needed to meet the tough daily demands of professional line striping contractors.

The SL pump delivers up to 1.7 gallon per minute output. This allows both models to support dual spray guns with very high volume spray tips. Both are as at home striping a convenience store parking lot as they are lining a professional football field.

The compact frame of the 4550 gives you big pump power with minimal space requirements, while the 6050 offers the ease of use of a dual swivel front wheel.

You will appreciate convenient design features like spray guns that can quickly be moved to any corner of the machine. Handlebar releasable swivel wheels have turnbuckle based RADIUS MEMORY™ for consistently smooth arcs & circles.

Like all Airlessco stripers and sprayers, they are ***Build to Last....Built to Perform.***

	SS4550	SS6050
Part No. 1 Gun Unit	305-403	305-305
Part No. 2 Gun Unit	305-404	305-307
Max Pressure	3300 PSI	3300 PSI
Output	1.50 GPM	1.70 GPM
Tip Size (1 Gun)	0.035 in.	0.041 in.
Tip Size (2 Gun)	0.029 in.	0.029 in.
Motor	Honda GX160	Honda GX160
Weight	215 lbs	242 lbs

## WARNING

***HANDLE THIS UNIT AS YOU WOULD A LOADED FIREARM!  
HIGH PRESSURE SPRAY CAN CAUSE EXTREMELY  
SERIOUS INJURY. OBSERVE ALL WARNINGS!***

### MANUAL NOTATIONS

**WARNING** - Alerts user to avoid or correct conditions that could cause bodily injury.

**CAUTION** - Alerts user to avoid or correct conditions that could cause damage to or destruction of equipment.

**IMPORTANT** - Alerts users to steps or procedures that are essential to proper equipment repair and maintenance.

**NOTE** - Identifies essential procedures or extra information.

***BEFORE OPERATING THIS UNIT, READ AND FOLLOW ALL SAFETY WARNINGS AND INSTRUCTIONS RELATED TO THE USAGE OF THIS EQUIPMENT ON PAGES 2, 3 & 4. READ, LEARN, AND FOLLOW THE PRESSURE RELIEF PROCEDURE ON PAGE 9 OF THIS MANUAL.***

All Service Procedures to be performed by an Authorized Airlessco Service Center ***ONLY***.  
***NO MODIFICATIONS*** or alterations of any ***AIRLESSCO*** Equipment or part is allowed.

# WARNINGS

## MEDICAL ALERT - Airless Spray Wounds

If any fluid appears to penetrate your skin, get **EMERGENCY MEDICAL CARE AT ONCE. DO NOT TREAT AS A SIMPLE CUT.** Tell the doctor exactly what fluid was injected. Have him read the following "NOTE TO PHYSICIAN".

**NOTE TO PHYSICIAN:** Injection in the skin is a traumatic injury. It is important to treat the injury surgically as soon as possible. **DO NOT DELAY** treatment to research toxicity. Toxicity is a concern with some exotic coatings injected directly into the blood stream. Consultation with a plastic surgeon or reconstructive hand surgeon may be advisable.

## WARNING

**HIGH PRESSURE SPRAY CAN CAUSE EXTREMELY SERIOUS INJURY. OBSERVE ALL WARNINGS. THIS SPRAYER IS FOR PROFESSIONAL USE ONLY.**

## INJECTION HAZARD

**FLUIDS UNDER HIGH PRESSURE FROM SPRAY OR LEAKS CAN PENETRATE THE SKIN AND CAUSE EXTREMELY SERIOUS INJURY, INCLUDING THE NEED FOR AMPUTATION.**

**NEVER** point the spray gun towards anyone or at any part of the body.

**NEVER** put hand or fingers over the spray tip. Do not use rag or other materials over your fingers. Paint will penetrate through material and into the hand.

**NEVER** try to stop or deflect leaks with your hand or body.

**ALWAYS** have gun tip guard in place when spraying.

**ALWAYS** lock gun trigger when you stop spraying.

**ALWAYS** remove tip from the gun to clean it.

**NEVER** try to "blow back" paint, it's not an air sprayer.

**ALWAYS** follow the **PRESSURE RELIEF PROCEDURE**, as shown on page 9, before cleaning or removing the spray tip or servicing any system equipment.

Be sure equipment safety devices are operating properly before each use.

**ALWAYS** tighten all fluid connections before each use.

## MEDICAL TREATMENT

If any fluid appears to penetrate your skin, get **EMERGENCY CARE AT ONCE.**

**DO NOT TREAT AS A SIMPLE CUT.**

- Go to an emergency room immediately.
- Tell the doctor you suspect an injection injury.
- Tell him what kind of material you were spraying with and have him read **NOTE TO PHYSICIAN** above.

## GENERAL PRECAUTION

**NEVER** alter equipment in any manner.

**NEVER** smoke while in spraying area.

**NEVER** spray highly flammable materials.

**NEVER** use around children.

**NEVER** allow another person to use sprayer unless he is thoroughly instructed on its' safe use and given this operators manual to read.

**ALWAYS** wear a spray mask, gloves and protective eye wear while spraying.

**ALWAYS** ensure fire extinguishing equipment is readily available and properly maintained.

**NEVER LEAVE SPRAYER UNATTENDED WITH PRESSURE IN THE SYSTEM. FOLLOW PRESSURE RELIEF PROCEDURES ON PAGE 9.**

## ALWAYS INSPECT SPRAYING AREA

Keep spraying area free from obstructions.

Make sure area has good ventilation to safely remove vapors. **NEVER** keep flammable material in spraying area. **NEVER** spray in vicinity of open flame or other sources of ignition. Spraying area must be at least 20 ft. away from spray unit.

## SPRAY GUN SAFETY

**ALWAYS** set safety lock on the gun in "**LOCKED**" position when not in use and before servicing or cleaning.

**DO NOT** remove or modify any part of gun.

**ALWAYS** remove spray tip when cleaning.

Flush unit with **LOWEST POSSIBLE PRESSURE.**

**CHECK** operation of all gun safety devices before each use. Be very careful when removing the spray tip or hose from gun. A plugged line contains fluid under pressure. If the tip or line is plugged, follow the **PRESSURE RELIEF PROCEDURE** as outlined on page 9.

## TIP GUARD

**ALWAYS** have the tip guard in place on the spray gun while spraying. The tip guard alerts you to the injection hazard and helps prevent accidentally placing your fingers or any part of your body close to the spray tip.

## SPRAY TIP SAFETY

**USE EXTREME CAUTION** when cleaning or changing spray tips. If the spray tip clogs while spraying, engage the gun safety latch immediately.

**ALWAYS** follow the **PRESSURE RELIEF PROCEDURE** before removing the spray tip to clean it.

**NEVER** wipe off build up around the spray tip.

**ALWAYS** remove tip & tip guard to clean **AFTER** pump is turned off and the pressure is relieved by following the **PRESSURE RELIEF PROCEDURE.**

**WARNINGS CONTINUED ON NEXT PAGE.....**

# WARNINGS - CONTINUED

## ALWAYS INSPECT SPRAYING AREA

Keep clear of moving parts when starting or operating the sprayer. Do not put your fingers into any openings to avoid amputation by moving parts or burns on hot parts. Precaution is the best insurance against an accident.

When starting the engine, maintain a safe distance from moving parts of the equipment.

Before adjusting or servicing any mechanical part of the sprayer, follow the **PRESSURE RELIEF PROCEDURE** on page 9, and remove the ignition cable from the spark plug to prevent accidental starting of sprayer.

## HOSES

Tighten all fluid connections securely before each use. High pressure fluid can dislodge a loose coupling or allow high pressure spray to be emitted from the coupling and result in an injection injury or serious bodily injury.

Use only hose that has a spring guard. The spring guard helps protect the hose from kinks or other damage which could result in hose rupture and cause an injection injury.

**NEVER** use a damaged hose, which can result in hose failure or rupture and cause in injection injury or other serious bodily injury or bodily damage. Before each use, check entire hose for cuts, leaks, abrasion or bulging of cover, or damage or movement of couplings. If any of these conditions exist, replace the hose immediately. Never use tape or any device to try to mend the hose as it cannot contain the high pressure fluid. **NEVER ATTEMPT TO RECOUPLE THE HOSE.** High pressure hose is not recoupleable.

Help prevent damage to the hose by handling and routing it carefully. Do not move the sprayer by pulling it with the hose.

## LABELING

Keep all labels on the unit clean and readable. Replacement labels are available from manufacturer.

## TOXIC FLUID HAZARD

Hazardous fluid or toxic fumes can cause serious injury or death if splashed in eyes or on skin, inhaled or swallowed. Know the hazards of the fluid you are using. Store & dispose of hazardous fluids according to manufacturer, local, state & national guidelines.

**ALWAYS** wear protective eyewear, gloves, clothing and respirator as recommended by fluid manufacturer.

## GROUNDING

Ground the sprayer and other components in the system to reduce the risk of static sparking, fire or explosion which can result in serious bodily injury and property damage.

### **ALWAYS GROUND ALL OF THESE COMPONENTS:**

1. Sprayer: Connect a ground wire and clamp (supplied) to a true earth ground.
2. Fluid Hose: use only grounded hoses.
3. Spray gun or dispensing valve: grounding is obtained through connection to a properly grounded fluid hose and pump.
4. Object being sprayed: according to your local code.
5. All solvent pails used when flushing should only be metal pails which are conductive.

Once each week, check electrical resistance of hose (when using multiple hose assemblies, check overall resistance of unpressurized hose must not exceed 29 megohms (max) for any coupled length or combination of hose lengths. If hose exceeds these limits, replace it immediately.

Never exceed 500 Ft. (150 m.) overall combined hose length to assure electrical continuity.

## KEEP CLEAR OF MOVING PARTS

Keep clear of moving parts when starting or operating the sprayer. Do not put your fingers into any openings to avoid amputation by moving parts or burns on hot parts. Precaution is the best insurance against an accident.

When starting the engine, maintain a safe distance from moving parts of the equipment.

Before adjusting or servicing any mechanical part of the sprayer, follow the **PRESSURE RELIEF PROCEDURE** on page 9, and remove the ignition cable from the spark plug to prevent accidental starting of sprayer.

**WARNINGS CONTINUED ON NEXT PAGE.....**

# WARNINGS - CONTINUED

## AVOID COMPONENT RUPTURE

This sprayer operates at 3000 psi (205 bar). **ALWAYS** be sure that all components and accessories have a maximum working pressure of at least 3000 psi to avoid rupture which can result in serious bodily injury including injection and property damage.

**NEVER** leave a pressurized sprayer unattended to avoid accidental operation of it which could result in serious bodily injury.

**ALWAYS** follow the **PRESSURE RELIEF PROCEDURE** whenever you stop spraying and before adjusting, removing or repairing any part of the sprayer.

**NEVER** alter or modify any part of the equipment to avoid possible component rupture which could result in serious bodily injury and property damage.

**NEVER** use weak or damaged or non-conductive paint hose. Do not allow kinking or crushing of hoses or allow it to vibrate against rough or sharp or hot surfaces. Before each use, check hoses for damage and wear and ensure all fluid connections are secure.

**REPLACE** any damaged hose. **NEVER** use tape or any device to mend the hose.

**NEVER** attempt to stop any leakage in the line or fittings with your hand or any part of the body. Turn off the unit and release pressure by following **PRESSURE RELIEF PROCEDURE**.

**ALWAYS** use approved high pressure fittings and replacement parts.

**ALWAYS** ensure fire extinguishing equipment is readily available and properly maintained.

**IMPORTANT:** United States Government safety standards have been adopted under the Occupational Safety & Health Act. These standards, particularly the General Standards, Part 1910, & the Construction Standards, part 1926 should be consulted.

### WARNING

Do not use halogenated solvents in this system. The prime valve, 2 gun manifold and most airless guns have aluminum parts and may explode. Cleaning agents, coatings, paints or adhesives may contain halogenated hydrocarbon solvents. **DON'T TAKE CHANCES!** Consult your material suppliers to be sure. Some of the most common of these solvents are: Carbontetrachloride, Chlorobenzene, Dichloroethane, Dichloroethyl Ether, Ethylbromide, Ethylchloride, Tetrachloroethane. Alternate valves and guns are available if you need to use these solvents.

### WHEN SPRAYING & CLEANING WITH FLAMMABLE PAINTS OR THINNERS:

1. When spraying with flammable liquids, the unit must be located a minimum of 25 feet away from the spraying area in a well ventilated area. Ventilation must be sufficient enough to prevent the accumulation of vapors.
2. To eliminate electrostatic discharge, ground the spray unit, paint bucket and spraying object. Use only high pressure airless hoses approved for 3000 psi which is conductive.
3. Remove spray tip before cleaning gun and hose. Make contact of gun with bucket and spray without the tip in a well ventilated area, into the grounded steel bucket.
4. Never use high pressure in the cleaning process. **USE MINIMUM PRESSURE.**
5. Do not smoke in spraying/cleaning area.

## PREVENT STATIC SPARKED FIRE/ EXPLOSIONS

**ALWAYS** be sure all equipment and objects being sprayed are properly grounded. **ALWAYS** ground sprayer, paint bucket and object being sprayed. See "grounding" on page 3 for detailed grounding information.

Vapors created when spraying can be ignited by sparks. To reduce the risk of fire, always locate the sprayer at least 20 feet (6 m.) away from the spray area. **DO NOT** plug in or unplug any electrical cords in the spray area, which can create sparks, when there is any chance of igniting vapors still in the air. Follow the coating & solvent manufacturers safety warnings and precautions.

Use only conductive fluid hoses for airless applications. Be sure gun is grounded through hose connections. Check ground continuity in hose & equipment. Overall (end to end) resistance of unpressurized hose must not exceed 29 megohms for any coupled length or combination of hose length. Use only high pressure airless hoses with static wire approved for 3000 psi.

## FLUSHING

Reduce the risk of injection injury, static sparking or splashing by following the specific cleaning procedure on page 6 and 9.

**ALWAYS** follow the **PRESSURE RELIEF PROCEDURE** on page 9.

**ALWAYS** remove the spray tip before flushing. Hold a metal part of the gun firmly to the side of a metal pail and use the lowest possible fluid pressure during flushing.

**NEVER** use cleaning solvents with flash points below 140 degrees F. Some of these are: acetone, benzene, ether, gasoline, naphtha. Consult your supplier to be sure.

**NEVER SMOKE IN THE SPRAYING/CLEANING AREA.**

**NEVER** leave water in fluid pump, to prevent freezing during storage.

## GAS ENGINE PRECAUTIONS

Place unit 25 feet away from spraying in ventilated area.

**NEVER** operate in buildings unless exhaust is piped outside.

**NEVER** allow hose to lay against engine mufflers or hot parts.

**NEVER** refill fuel tank while engine is hot or is running.

# SETTING UP

## 1. CONNECT THE HOSE AND GUN

- Remove the plastic cap plug from the outlet and screw a conductive or grounded 3000 psi spray hose onto fluid outlet.
- Connect an airless spray gun to the other end of the hose, but do not install the spray tip yet!

**NOTE:** Do not use thread sealer on swivel unions as they are made to self seal.

**NOTE:** The first 50' of hose should always be 3/8".

## 2. FILL THE PACKING NUT/WET CUP

Fill the Packing Nut/Wet Cup 1/3 full with Airlessco Throat Seal Oil (TSO). **FIG 1 BELOW.**

**FIG. 1**

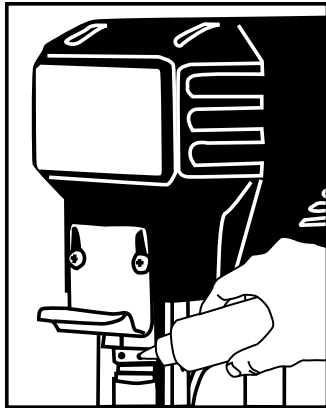

## 3. CHECK THE ENGINE OIL LEVEL

- Unscrew the oil fill plug. The dipstick is attached to the plug.
- Without threading the plug into place, check to be sure the oil is up to the top mark on the dipstick.
- If oil is needed, refer to engine manual.

## 4. FILL THE FUEL TANK

**WARNING:** Fuel spilled on a hot surface can cause a fire or explosion and cause serious bodily injury and property damage. Always shut off the engine and let it cool before filling the tank, and carefully follow steps a - c below being sure not to spill any fuel.

- Close the fuel shutoff valve.
- Use only clean, fresh, well-known brands of unleaded regular grade gasoline.
- Remove the fuel cap and fill tank. Be sure the air vent in the fill cap is not plugged so fuel can flow to the carburetor, then replace the cap.

# FLUSHING

## 1. NEW SPRAYER

Your unit was factory tested in an anti-freeze solution which was left in the pump. Before using oil-base paint, flush with mineral spirits only.

Before using water-base paint flush with mineral spirits, followed by soapy water, then a clean water flush.

## 2. CHANGING COLORS

Flush with a compatible solvent such as mineral spirits or water.

## 3. CHANGING FROM WATER-BASE TO OIL-BASE PAINT

Flush with soapy water, then mineral spirits.

## 4. CHANGING FROM OIL-BASE TO WATER-BASE PAINT

Flush with mineral spirits, followed by soapy water, then a clean water flush.

## 5. STORAGE

Oil-base paint: Flush with mineral spirits.

Water-base paint: Flush with water, then mineral spirits and leave the pump, hose and gun filled with mineral spirits.

For longer storage, use mixture of mineral spirits and motor oil (half & half). Shut off the sprayer, follow **PRESSURE RELIEF PROCEDURE** on page 9 to relieve pressure and make sure prime valve is left open.

## 6. START UP AFTER STORAGE

Before using water-base paint, flush with soapy water and then a clean water flush.

When using oil-base paint, flush out the mineral spirits with the material to be sprayed.

# HOW TO FLUSH

1. Be sure the gun safety latch is engaged and there is no spray tip in the gun. Refer to Fig. 2. Refer to your separate instruction manual provided with your gun on its safety features and how to engage safety latch.
2. Pour enough clean, compatible solvent into a large, empty metal pail to fill the pump and hoses.
3. Place the suction tube into the pail or place the pail under the pump.
4. Turn pressure control knob to low. Refer to Fig. 4.
5. Open the prime valve to the open - "Priming Position". This will allow an easy start. Refer to Fig. 3.
6. Turn the engine ON/OFF switch to ON.
7. Move the choke toward the closed position as per Fig.5.
8. Move the throttle lever slightly to the left as per Fig.5.
9. Turn the fuel valve ON as per Fig. 5. Pull the start rope. Pull the engine over against compression stroke and then let the rope rewind slowly into the starter. Pull firmly and rapidly to start the engine. Do NOT drop the rope. Hold on to the handle while rewinding, or the rope may rewind improperly and jam the assembly. If the engine does not start, open the choke a little more. If the engine floods, open the choke all the way and continue cranking.
10. After the engine is warm, gradually close the choke, raise the RPM of engine slightly by moving throttle to the left. Close the prime valve. Refer to Fig. 3
11. Point the gun into the metal pail and hold a metal part of the gun firmly against the pail Refer to fig.6.
12. Disengage the gun safety latch and squeeze the gun trigger. At the same time, slowly turn the pressure control knob clockwise just enough to move liquid at low pressure.
13. Allow the pump to operate until clean solvent comes from the gun.
14. Release the trigger and engage the gun safety latch.
15. If you are going to start spraying, place the pump or suction tube into the supply container. Release the gun safety latch and trigger the gun into another empty, metal container, holding a metal part of the gun firmly against the metal pail (Fig. 6), forcing the solvent from the pump and hose. When paint starts coming from gun, turn pressure control knob to minimum pressure, place prime valve in prime (open) position and engage the gun safety latch.
16. If you are going to store the sprayer, remove the suction tube or pump from the solvent pail force the solvent from the pump and hose. Engage the gun safety latch and refer to the "Storage" Procedure on page 5. Step 5.
17. Whenever you shut off the sprayer follow the **PRESSURE RELIEF PROCEDURE** warning on page 9.

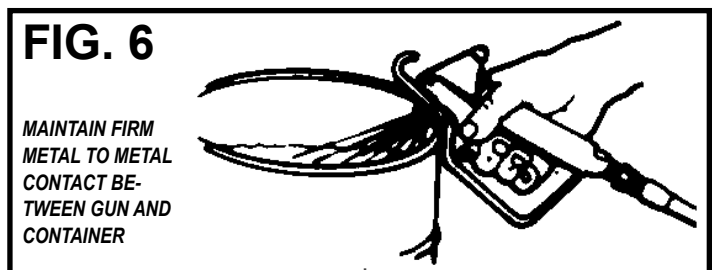
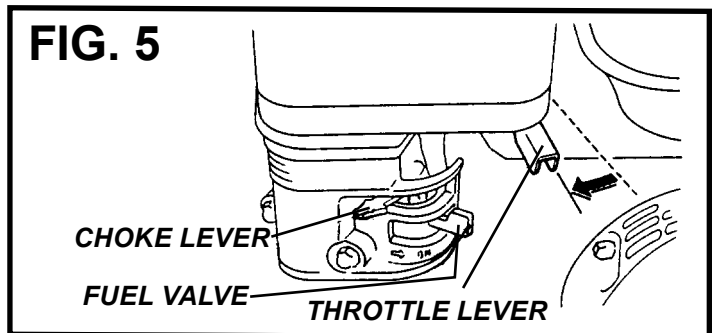
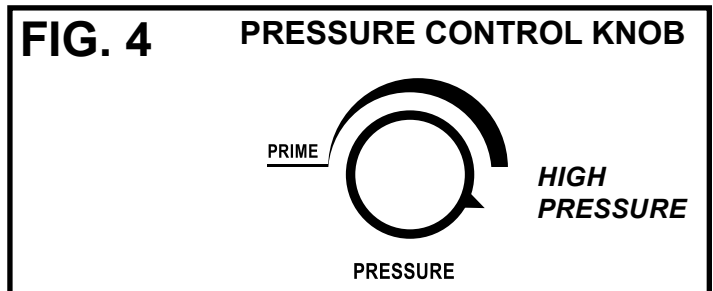
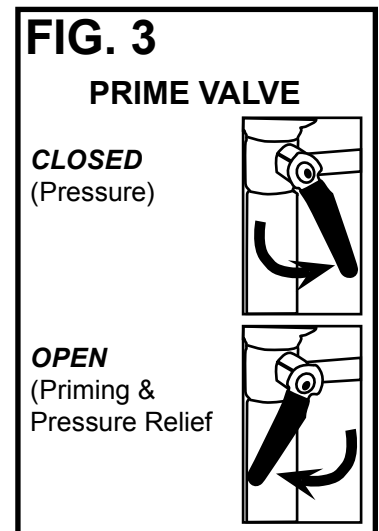

**WARNING:** To reduce the risk of static sparking, which can cause fire or explosion, always hold a metal part of the gun firmly against the metal pail when flushing. This also reduces splashing. Refer to Fig 6.



# STARTING UP

## 1. LEARN THE CONTROLS

**PRESSURE CONTROL KNOB** - used to adjust pressure only. Turn clockwise to increase pressure and counterclockwise to decrease pressure. (See Fig. 4)  
**PRIME & PRESSURE RELIEF VALVE** - Turn to **OPEN** position (see Fig. 3) to prime the pump. Turn to the **CLOSED** position to spray.

**FOLLOW "PRESSURE RELIEF PROCEDURES" ON PAGE 9 WHENEVER YOU:**

- are instructed to relieve pressure
- stop spraying
- checking or servicing any of the system equipment.
- or installing or cleaning the spray tip.

**HANDLE SPRAY SYSTEM AS YOU WOULD A LOADED FIREARM!**

**CAUTION:** Do not start engine without fluid pump having enough fluid so that it can be primed. Running fluid pump dry will decrease life of the pumps packings.

## 2. PREPARE THE MATERIAL

- Prepare the material according to the material manufacturer's recommendations.
- Place pump or suction tube into material container.

## 3. STARTING THE SPRAYER

**SEE FIGURE 3 & 6 ON PREVIOUS PAGE**

- Prime Valve must be open - priming position.
- Pressure Control Knob must be in low pressure.
- Follow the procedure under "How to Flush", page 6, steps 6 through 12.

### WARNING

To stop the unit in an emergency or before performing any service or maintenance procedure follow the **PRESSURE RELIEF PROCEDURE** on page 9 to relieve the fluid pressure.

## 4. PRIME THE PUMP

- Allow pump to operate until paint comes from gun.
- Release the trigger and engage the gun safety latch.
- Turn Prime Valve **OPEN** to the prime position ensuring the pressure is released from the system.
- Turn Pressure Control Knob to minimum pressure.
- Install spray tip onto gun.
- Close the prime valve to the pressure position.
- Turn the pressure control knob to desired spray pressure.
- Disengage the gun safety lock and you are ready to start spraying.

### WARNING

If you spray into the paint bucket, always use the lowest spray pressure and maintain firm metal to metal contact between gun and container. See page 6, Fig 6.

## 5. ADJUSTING THE PRESSURE

- Turn the Pressure Control Knob Clockwise to increase pressure and counterclockwise to decrease pressure.
- Always use the lowest pressure necessary to completely atomize the material.

**NOTE:** Operating the sprayer at higher pressure than needed, wastes material, causes early tip wear, and shortens sprayer life.

- If more coverage is needed, use a larger tip rather than increasing the pressure.
- Check the spray pattern. The tip size and angle determines the pattern width and flow rate.

## 6. REDUCING CLUTCH WEAR

- The first 50 feet of airless spray hose should be 3/8", the larger diameter works as a pulsation damper and saves unnecessary cycling of the clutch. A minimum of 100 feet of hose should be used.
- Adjust the Engine Speed and Pump Pressure. First set the throttle lever to the maximum RPM setting (fully left). Trigger the gun onto a test paper to check the spray pattern and atomization. Adjust the Pressure Control Knob until you get a good pattern. Reduce RPM of engine to support pressure without laboring engines.

CONTINUED ON NEXT PAGE.....

# STARTING UP CONTINUED

## 7. CLEANING A CLOGGED TIP

- a. Follow **PRESSURE RELIEF PROCEDURE** on page 9.
- b. Clean the front of the tip frequently (with toothbrush only) during the day to keep material from building up and clogging the tip.
- c. To clean and clear a tip if it clogs, refer to the separate instruction manual received with your gun and nozzle.

### IMPORTANT WARNING

Always follow the **PRESSURE RELIEF PROCEDURE** on page 9 before performing any service or maintenance procedure.

### WARNING

Never hold your body, fingers, or hand in a rag in front of the spray tip when cleaning or checking it for a cleared tip. Always point the gun toward the front or into a waste container when checking to see if the tip is cleared or when using a self-cleaning tip.

### THERE IS AN EASY WAY TO KEEP THE OUTSIDE OF THE TIP CLEAN FROM MATERIAL BUILD-UP:

Every time you stop spraying, for even a minute, lock the gun and submerge the gun into a small bucket of thinner comparable with the material sprayed. Thinner will dissolve the build up of paint on the outside of tip, tip guard and gun much more effectively than if the paint dries out completely.

### WARNING

Clogged standard flat tip - clean only after the tip is removed from the gun. Follow the **PRESSURE RELIEF PROCEDURE** Warning on Page 9.

## 8. WHEN SHUTTING OFF SPRAYER

- a. Whenever you stop spraying, even for a short break, follow the "**PRESSURE RELIEF PROCEDURE**".
- b. Clean the tip & gun as recommended in the spray gun instruction manual.
- c. Flush the sprayer at the end of each work day, if the material you are spraying is water-based, or if it could harden in the sprayer overnight. See "Flushing". Use a compatible solvent to flush, then fill the pump and hoses with an oil based solvent such as mineral spirits.
- d. For long term shutdown or storage, refer to the "Flushing" section of this manual.

### WARNING

Be sure to relieve pressure in the pump after filling with Airlessco Pump Conditioner.

# PRESSURE RELIEF PROCEDURE

## IMPORTANT!

**TO AVOID POSSIBLE SERIOUS BODY INJURY, ALWAYS FOLLOW THIS PROCEDURE WHENEVER THE SPRAYER IS SHUT OFF, WHEN CHECKING IT, WHEN INSTALLING, CHANGING OR CLEANING TIPS, WHENEVER YOU STOP SPRAYING, OR WHEN YOU ARE INSTRUCTED TO RELIEVE THE PRESSURE.**

1. Engage the gun safety latch. Refer to the separate instruction manual provided with your gun on its safety features and how to engage safety latch.

2. Turn the unit off.

3. Disengage the gun safety latch and trigger the gun to relieve residual fluid pressure.

**HOLD METAL PART OF THE GUN IN CONTACT WITH GROUNDED METAL PAIL. USE MINIMUM PRESSURE !**

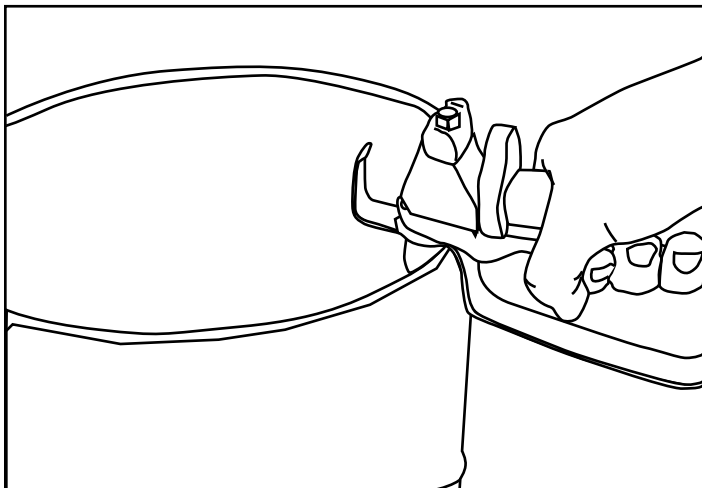

4. Turn Prime/Pressure Relief Valve (PR Valve) to the open (priming) position to relieve residual fluid pressure.

5. Re-engage gun safety latch and close Prime/Pressure Relief Valve.

If the **SPRAY TIP OR HOSE IS CLOGGED**, follow Step 1 through 5 above. Expect paint splashing into the bucket while relieving pressure during Step 4.

If you suspect that pressure hasn't been relieved due to damaged Prime/Pressure Relief Valve or other reason, engage the gun safety latch and take your unit to an authorized Airlessco Service Center.

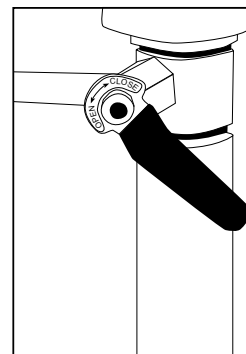

## DAILY MAINTENANCE

1. Keep the displacement pump packing nut/wet cup lubricated with Airlessco TSO (Throat Seal Oil) at all times. The TSO helps protect the rod and the packings.
2. Inspect the packing nut daily. Your pump has a patented Triple Life Packing System. Packing life will be extended a minimum of three times if the following "Packing Adjustment" procedure is followed:

**IF SEEPAGE OF PAINT INTO THE PACKING NUT AND/OR MOVEMENT OF THE PISTON UPWARD IS FOUND (WHILE NOT SPRAYING), THE PACKING NUT SHOULD BE TIGHTENED ENOUGH TO STOP LEAKAGE ONLY, BUT NOT ANY TIGHTER. OVERTIGHTENING WILL DAMAGE THE PACKINGS AND REDUCE THE PACKING LIFE.**

# LINE STRIPING OPERATION

## 1. CHOOSE THE GUN ARM POSITION

There are 4 holes in the frame on the 4550 & 6050. In a standard set up, the gun arm would be mounted in the right hand near the single wheel. This allows for an easier visual check for straight line striping and for basic arc striping.

## 2. SETTING UP THE GUNS

- a. Ensure that striping tips are in the guns.
- b. Pick a tip size for the desired line width.  
**EXAMPLE:** a 317ST tip for a four inch line.
- c. Place gun into the gun holder, so that the top of the taper on the gun handle is flush with the edge of the gun holder.
- d. Set gun height for the desired line width. Adjust height by loosening the small black handle on the gun holder assembly and slide the gun arm to the correct height. Now tighten the handle. This will require some experimentation to find the correct height. It is suggested that tape, or some other method is used to mark the height of commonly used settings.
- e. Set spacing between the two guns by loosening the black handle on the gun arm. Slide to the desired width and tighten.
- f. Attach the swivel heads to the guns if painting curbs or wide stripes.
- g. Angle the guns slightly forward. This allows the spray pressure from the guns to help blow dirt and debris out of the path of the new stripes.

## 3. CABLE TENSION ADJUSTMENT

Once the handle and gun arm assemblies are set up to the preferred positions, pressurize the unit and trigger each gun to ensure that they activate and release correctly. If not, adjust the cable tension as follows:

- a. Locate the adjustment knobs on the base of the gun trigger, where the cable connects to the gun trigger assembly.
- b. Loosen the locking nut and move the adjusting screw until the slack has been removed from the cable.
- c. Tighten locking nut and retest gun triggers for proper function.

**NOTE: THERE IS AN ADDITIONAL CABLE ADJUSTMENT WHERE THE CABLE ATTACHES TO THE GUN HOLDER ASSEMBLY. USE ONLY IF THE GUN TRIGGER ADJUSTMENT IS INSUFFICIENT.**

## 4. ALIGN SWIVEL WHEEL ASSEMBLY

### STRAIGHT LINES

- a. SS6050: Loosen the two ratchet handles on the swivel wheel assembly, just enough to be able to move the assembly by hand. Lift the ratchet handle to move the handle without turning the attached bolts, then press down and turn handle counterclockwise to loosen.

SS4550: Stripers are factory aligned, but if necessary, loosen the two bolts (fig. 35, item 19) on the swivel wheel assembly, just enough to be able to move the wheel by hand. Align wheel and re-tighten bolts.

- b. Place the turnbuckle over the two mounting nubs on the frame.
- c. Pressurize the unit with water and Airlessco's Pump Conditioner and spray out several lines with the swivel assembly in the locked position. Use the turnbuckle to fine tune the alignment of the wheels, until the stripes are straight.



**IMPORTANT:** Loosen ratchet handles prior to any turnbuckle adjustment.

- d. Tighten the jam nuts on the turnbuckle to affix the turnbuckle length for future reference.
- e. Tighten the ratchet handles (6050) or bolts (4550.)

### CURVES AND ARCS

Basically the same as above, except the swivel wheel assembly is set at angle. The swivel assembly can be adjusted to 30 degrees either side of straight ahead. If you have arcs that you paint regularly, purchase additional turnbuckles (PN. 136-231) and keep them set to those arc sizes.

## 5. MISCELLANEOUS OPERATIONS

- a. **CURBS:** Adjust gun to desired height and turn swivel head towards curb.
- b. **WIDE STRIPES:** Install wider fan striping tips and raise the gun height to achieve the desired width line. Also angle guns slightly towards each other to get an even coat of paint.
- c. **STENCILS:** Install standard spray tip on the outer gun. Remove this gun from the gun holder and spray out the stencils.
- d. **STANDARD PAINTING:** Same as stencils, but use additional paint hose as required.

# AIRLESS SPRAY GUN OPERATION

## SPRAY

Attach spray gun to airless unit and tighten fittings securely. Set the gun safety latch. (Also may be called gun safety lock, or trigger lock)

\* The gun safety latch should always be set when the gun is not being triggered.

Read all warnings and safety precautions supplied with the spray gun and in product manual.

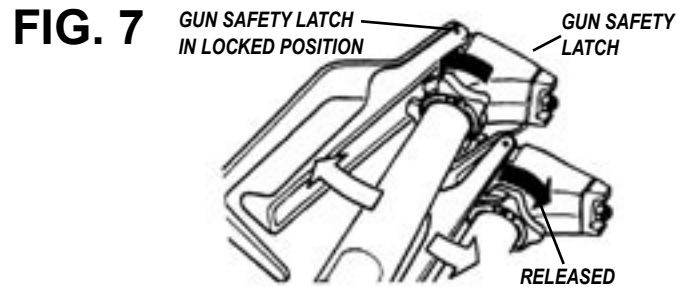

## MAJOR COMPONENTS OF SPRAY GUN AND REVERSIBLE SPRAY TIP

FIG. 8

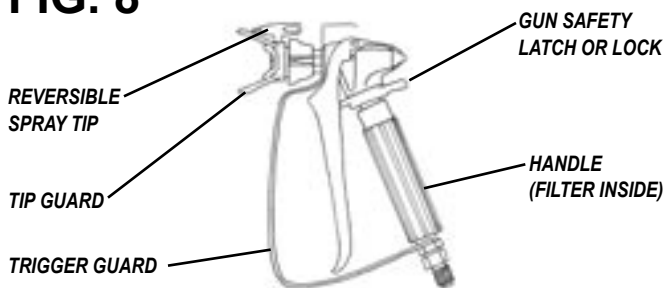
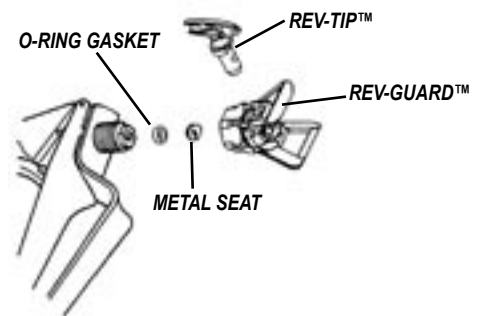

FIG. 9



## SPRAY TIP ASSEMBLY

1. Be sure pressure relief procedure is followed before assembling tip and housing to the gun.
2. Lock gun safety latch.
3. Insert REV-TIP™ cylinder into the REV-GUARD™ (guard housing assembly).
4. Guide metal seat into REV-GUARD™ (guard housing assembly) through retaining nut & turn until it seats against the cylinder.
5. Insert O-Ring gasket on metal seat so it fits in the grooves.
6. Finger tighten REV-GUARD™ retaining nut onto the gun.
7. Turn guard in the desired position.
8. Completely tighten the retaining nut.

FIG. 10

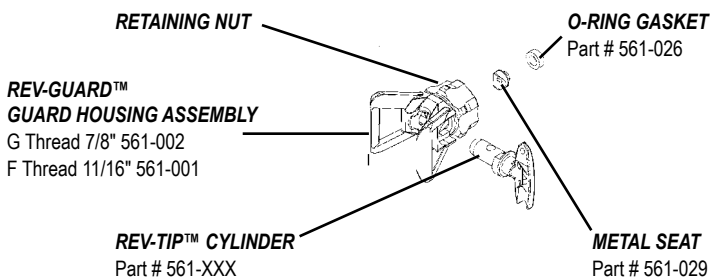

## CLEANING FILTER IN GUN HANDLE

To clean the filter, use a brush dipped in an appropriate solvent. Change or clean filters at least once a day. Some types of latex may require a filter change after four hours of operation.

## TO REMOVE CLOGS FROM SPRAY TIP

1. Lock gun safety latch.
2. Turn REV-TIP™ handle 180 degrees.
3. Disengage trigger lock & trigger gun into pail.
4. If the REV-TIP™ handle appears locked (resists turning), loosen the retaining nut. The handle will now turn easily.
5. Engage gun safety latch & return handle to the spray position.

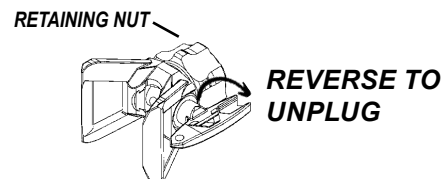

Spray Position Shown

## CLOGGED FLAT TIP

Should the spray tip become clogged, relieve pressure from hose by following the **"PRESSURE RELIEF PROCEDURE."** Secure gun with the safety latch, take off guard, take out the tip, soak in appropriate solvent & clean with a brush. (Do not use a needle or sharp pointed instrument to clean the tip. The tungsten carbide is brittle and can chip.)

## CLEANING SPRAY GUN

Immediately after the work is finished, flush the gun out with a solvent. Brush pins with solvent and oil them lightly so they will not collect dried paint.

# AIRLESS SPRAY GUN

FIG. 11

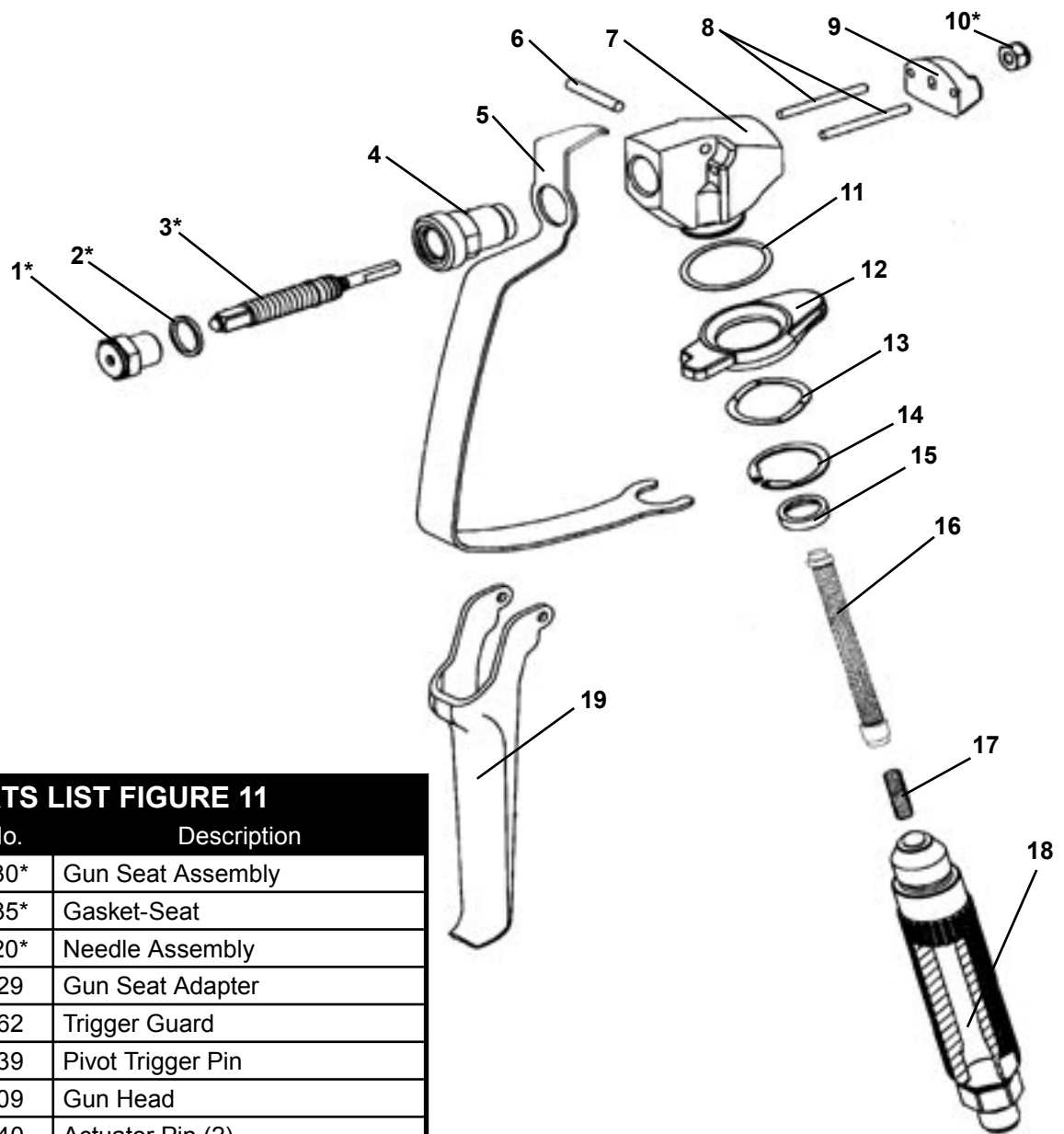

## PARTS LIST FIGURE 11

Item No.	Part No.	Description
1	120-530*	Gun Seat Assembly
2	120-535*	Gasket-Seat
3	120-520*	Needle Assembly
4	120-529	Gun Seat Adapter
5	120-562	Trigger Guard
6	120-539	Pivot Trigger Pin
7	120-509	Gun Head
8	120-540	Actuator Pin (2)
9	120-536	Gun Plate
10	120-038*	Nut
11	120-056	Plastic Washer
12	120-538	Gun Trigger Lock
13	120-055	Wave Washer
14	120-049	Retaining Ring
15	120-082	Handle Seal
16	120-090CX	Gun Filter-Coarse
	120-090FX	Gun Filter-Fine
17	120-088	Spring
18	120-099	Gun Handle Assembly
19	120-506	Gun Trigger
*	120-534	Gun Repair Kit

# AIRLESS SPRAY TROUBLESHOOTING

DEFECTS	CAUSE	CORRECTION
Coarse spray	Low pressure	Increase the pressure
Excessive fogging (overspray)	High pressure Material too thin	Reduce the pressure to satisfactory pattern distribution Use less thinner
Pattern too wide	Spray angle too large	Use smaller spray angle tip
Pattern too narrow	Spray angle too small	use larger spray angle tip ( if coverage is OK, try tip in same nozzle group)
Too much material	Nozzle too large Material too thin Pressure too high	use smaller nozzle  reduce pressure
Too little material	Nozzle too small	use next larger nozzle material too thick
Thin distribution in center of pattern "horns"	Worn tip Wrong tip	change to new tip use nozzle with narrow spray angle
Thick skin on work	Material too viscous Application too heavy	thin cautiously reduce pressure and/or use tip in next smaller nozzle group
Coating fails to close & smooth over	Material too viscous	thin cautiously
Spray pattern irregular, deflected	Orifice clogged Tip damaged	clean carefully replace with new tip
Craters or pock marks, bubbles on work	Solvent balance	use 1 to 3% "short solvents remainder "long" solvents (this is most likely to happen with material of low viscosity, lacquers, etc.)
Clogged screens	Extraneous material in paint Coarse pigments Poorly milled pigments (paint pigments glocculate)	Clean screen Use coarse screen if orifice size allows. Use courser screen, larger orifice tips. Obtain ball milled paint. If thinner has been added, test to see if a cover screen. Incompatible drop placed on top of paint mixes or flattens out on the paint mixture & thinners on the surface. If not, try different thinner in fresh batch of paint.

## TEST THE PATTERN

**GOOD, FULL**



**SPOTTY PATTERN, INCREASE PRESSURE**



# LINE STRIPING TIP CHART

**NOTE: STRIPING TIPS SHOULD NOT BE USED FOR REGULAR SPRAYING.**

**REV-TIP™** for Striping, Part Number 562-xxxST

## TIP IDENTIFICATION

- 1st 3-digits identifies it as a **REV-TIP™** for airless line striping (Part Number 562-xxxST).
- 4th digit is the fan width - the number is half the fan width, e.g., 2 means a 4" line width.
- 5th and 6th digits are for the orifice size and is measured in thousandths of an inch, e.g., 17 = 0.017 inch.

The higher the number, the larger the tip.

## REVERSIBLE STRIPING TIP SIZE CHART

### REV-TIP™ FOR STRIPING 562-XXXST

FAN WIDTH (6" FROM SURFACE)		ORIFICE SIZE (INCHES)				
INCHES	MILLIMETERS	.013	.015	.017	.019	.021
1-2	25-51	113ST	115ST	117ST		
2-4	51-102		215ST	217ST	219ST	221ST
4-6	102-152		315ST	317ST	319ST	321ST
6-8	152-203		415ST	417ST	419ST	421ST
Striping paint		Oil Base	Oil Base	Latex	Latex	Latex

REV-TIP™ protected By U.S. Patent No. 6,264,115. Other U.S. & foreign patents applied for.

## TIP REPLACEMENT

During use, high pressure will cause the orifice to grow larger. This destroys the pattern or will leave tailing or two heavy lines on the outside of the pattern. **REPLACE SPRAY TIP FREQUENTLY!**

# OIL AND LUBRICATION INSTRUCTIONS

**FIG. 12**

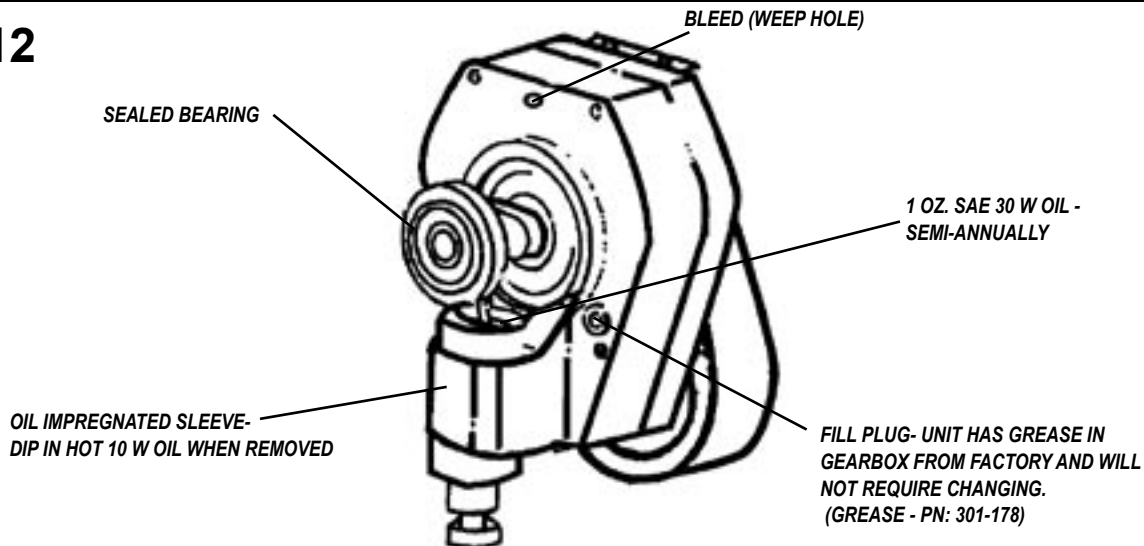



# REGULAR MAINTENANCE

1. Always stop the pump at the bottom of its stroke when you take a break or at the end of the day. This helps keep material from drying on the rod, damaging the packings.
2. Keep the displacement pump packing nut/wet cup 1/3 full of Airlessco Throat Seal Oil at all times. The TSO helps protect the packings and rod.
3. Lubricate Connecting Rod Pin every 3 months.
4. Inspect the packing nut daily. Your paint pump has Airlessco's patented "Triple Life Packing System". Packing life will be extended a minimum of 3 times if the proper packing tightening procedure is followed!

## **PACKING TIGHTENING PROCEDURE:**

Inspect the packing nut daily! If seepage of paint into the packing nut and/ or movement of the piston upward is found (while not spraying), the packing nut should be tightened enough to stop leakage only, but not any tighter.

**OVERTIGHTENING WILL DAMAGE THE PACKINGS** and reduce the packing life to the life of other piston pumps.

# FIELD TROUBLESHOOTING

PROBLEM	CAUSE	SOLUTION
There is spitting from the gun.	The fluid supply is low or empty. Air entrapped in the fluid pump or hose.	Refill the supply container. Check for loose connections on the siphon assembly, tighten, then reprime pump.
Paint leaks into the wet cup	The packing nut/wet cup is loose. The upper packings are worn or damaged. Worn Piston Rod.	Tighten just enough to stop leakage. Replace the packings. See pages 18-19.  Replace Piston Rod
The engine operates, but the paint pump doesn't cycle.	The pressure setting is too low. The clutch is not engaged. The displacement pump is seized.	Increase the pressure. See page 6. See Troubleshooting pg. 23. Service the pump. See page 18-19.
The engine and displacement pump operates, but paint pressure is too low or none	The pressure setting is too low. The tip or gun filter is clogged. The tip is worn. The fluid displacement pump filter is clogged. There is a large pressure drop in the fluid hose.	Increase the pressure, see page 6. Remove the tip and/or filter and clean them. Replace Tip. Clean the filter.  Use a larger diameter hose.
The displacement pump operates, but the output is too low on the downstroke or both strokes.	The inlet valve ball is not seating properly.	Service the inlet valve see page 17.
The displacement pump operates, but the output is too low on the upstroke.	The outlet valve ball is not seating properly.  The lower packings are worn or damaged.	Service the outlet valve per page 17.  Replace the packings. See page 18-19.
Clutch does not engage. Clutch slippage.		See Troubleshooting page 23. Call Authorized Service Center.
Engine stops		Refer to Engine Manual.

# SERVICING THE FLUID PUMP

**NOTE: CHECK EVERYTHING IN THE TROUBLESHOOTING CHART BEFORE DISASSEMBLING THE SPRAYER.**

## FLUID PUMP DISCONNECT

1. Flush out the material you are spraying, if possible.
2. Follow the Pressure Relief Procedure on page 8. Stop the pump in the middle of down stroke.
3. Remove the suction tube and fluid hose (if so equipped) from the fluid pump.
4. Remove the connecting rod shield from the pump.
5. Remove 2 retaining rings and slip the sleeve of the coupling down and remove both coupling halves. This will disconnect fluid pump from the connecting rod.
6. Using a 7/8" box wrench, disconnect the high pressure fluid line from the pump.
7. Using a 9/16" wrench, unscrew the two tie rod locknuts.
8. Pull the pump off the tie rods.

**FIG. 13**

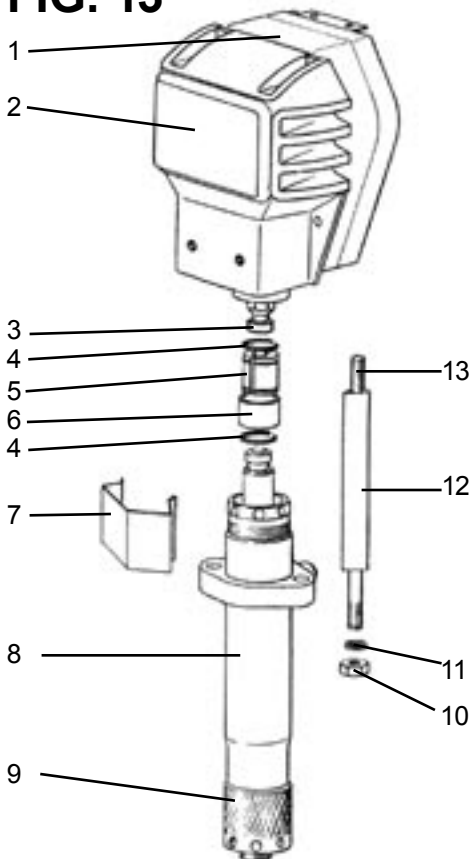

## FLUID PUMP REINSTALL

1. Loosen the packing nut & extend piston rod to fully up position. Slip sleeve over the piston rod. See figure 15.
2. Insert one of the retaining rings through the packing nut and rest the sleeve on top of it. See figure 16 & 17.
3. Connect the connecting rod with the fluid pump by installing the coupling halves. Slide sleeve over the coupling halves and secure with retaining ring. See figure 18.
4. Remove the retaining ring from the packing nut and insert into coupling halves. See figure 19
5. Secure the fluid pump housing to the tie rods and screw locknuts with washers on loosely.
6. Tighten the tie rod locknuts evenly to 30 ft. lb.  
**NOTE: AFTER ALL THE ROD LOCKNUTS ARE TIGHT, THE ALIGNMENT OF BOTH RODS SHOULD ALLOW EASY ASSEMBLY AND DISASSEMBLY OF THE COUPLING. IF ANY BINDING, LOOSEN AND RETIGHTEN ALL THE ROD LOCKNUTS TO IMPROVE THE ALIGNMENT. MISALIGNMENT CAUSES PREMATURE WEAR OF SEAL AND PACKINGS.**
7. Tighten packing nut clockwise until resistance against the packings can be felt. Turn it one full turn more.
8. Start the pump and operate it slowly (at low engine speed) to check the piston rod for binding. Adjust tie rod lock nuts if necessary to eliminate binding.
9. Prime the unit and run at maximum pressure for several minutes, then release the pressure & repeat step 7.
10. Fill the wet cup (packing nut) with five drops of TSO (Throat Seal Oil).

**FIG. 14**



**FIG. 15**

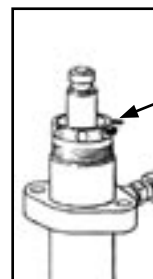

**FIG. 16**

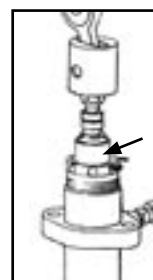

**FIG. 17**

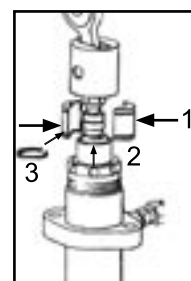

**FIG. 18**



## PARTS LIST FIGURE 13

Item No.	Part No.	Description
1	301-203-99	Gearbox 3/4" (810/910E)
	301-204-99	Gearbox 1" (1100/1110E)
2	301-320	Cover
3	301-046	Rod End
4	189-048	Retaining Ring
5	189-046	Coupling Set
6	198-047	Retaining Sleeve
7	301-467	Front Shield
8	187-410	SL Paint Pump Assy
9	187-002	Suction Nut
10	140-051	Nut (2)
11	140-035	Lock Washer (2)
12	301-059	Spacer (2)
13	100-328	Stud (2)

# SERVICING INLET & OUTLET VALVES

## DISASSEMBLY OF THE OUTLET VALVE

1. Using the rod collar tool (189-211), screw the suction nut, containing intake seat support, off of the fluid body. See Fig. 19.
2. Remove the inlet seat, O-ring, inlet ball and inlet retainer with O-ring. See Fig. 19.
3. Clean all parts and inspect them for wear or damage, replacing parts as needed. Old O-rings should be replaced with new ones.

**NOTE: INLET SEAT (187-065) IS REVERSIBLE.**

4. Clean inside of fluid body.
5. Reassemble the valve and screw it onto the fluid body if no further service is needed.

## SERVICING THE OUTLET VALVE

1. Complete all steps of the Fluid Pump Disconnect procedure on page 16.
2. Screw the suction nut off the pump and remove inlet valve assembly.
3. Using the rod collar tool, loosen the packing nut and push the piston down and out of the fluid body.
4. Place piston holder (187-248) in a vise. Slide piston into holder and lock in place with a 1/4" pin (187-250).
5. Clean all parts and inspect them carefully for wear or damage. Inspect the outside of the piston rod for scoring or wear. Replace these parts if needed. A worn piston rod will cause premature wear of packings.
6. Using 3/8" allen wrench to unscrew retainer from piston.
7. Remove outlet seat, O-ring, outlet ball and outlet retainer.
8. Inspect outlet ball and seat for wear. Replace as required.

**NOTE: OUTLET SEAT (187-061) IS REVERSIBLE.**

9. Install parts back into piston rod as per Fig. 20. Place two drops of loctite No. 242 (blue) on threads of the retainer before assembling and torque to 20 ft-lbs.

FIG. 19

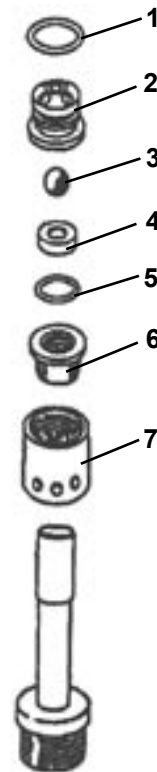
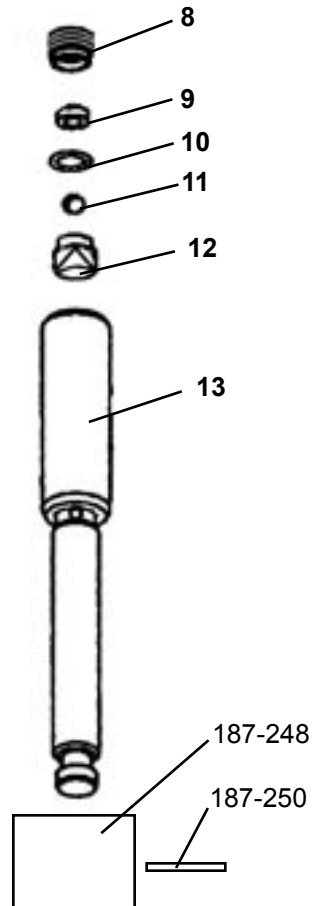

FIG. 20



## PARTS LIST FIGURE 19 & 20











Item No.	Part No.	Description
1	106-014	Black O-Ring
2	187-016	Inlet Retainer
3	187-020	Inlet Ball
4	187-065	Inlet Seat
5	106-017	White O-Ring
6	187-001	Suction Fitting
7	187-002	Suction Nut
8	187-051	Retainer
9	187-061	Outlet Seat
10	106-021	White O-Ring
11	115-022	Outlet Ball
12	187-062	Outlet Retainer
13	187-330-99	Piston

# PACKING REPLACEMENT PROCEDURES

## DISASSEMBLY OF THE FLUID PUMP

1. Unscrew & remove the packing nut.
2. Push the piston rod down through the packings & out of the pump.
3. Now push the packing removal tool up through the pump & remove from the top bringing the packings, spacer & springs along with it, leaving the fluid body empty.  
**\*NOTE: MAKE SURE ALL PACKINGS & GLANDS HAVE BEEN REMOVED FROM THE FLUID PUMP.**
4. Clean inside of fluid body.
5. Disassemble all parts & clean for reassembly. Discard any old packings. Save the metal upper glands. Replace metal lower glands with new metal glands from the packing kit.  
**\* NOTE: IF THE OLD PACKING HAD A METAL GLAND FOR (187-058), DISCARD & REPLACE WITH A NEW PLASTIC ONE FROM PACKING KIT.**
6. Lubricate leather packing in lightweight oil for 10 minutes prior to reassembly.

## REASSEMBLY

1. Take the lower metal male gland and place it down on the flat side. 
2. Take three of the lower polyethylene V-packings and two of the leather V-packings and place onto your male gland in the following order with the inverted side down:  polyethylene, leather, polyethylene, leather, polyethylene.
3. Take the female adaptor, which is inverted on both sides,  and place it on top of your assembled lower packings.
4. Follow step 2 above but with packings inverted side up. 
5. Take the second lower male gland and place it on top of your assembled packings with the rounded side down. 
6. Take your assembled glands & packings (13 pieces all together) and slide on to the lower half of the piston.
7. Take the spacer and slide over the top of the piston (it doesn't matter which direction it sits), falling onto the lower packings.
8. Take the three Belleville Springs and slide over the top of the piston in the following order:
  - \* First spring, curve facing down 
  - \* Second spring, curve facing up 
  - \* Third spring, curve facing down 
9. Take the upper male gland and place it with the rounded side up. 
10. Take the three upper polyethylene V-packings and two leather packings and assemble with the inverted side down,  on to the male gland in the following order: polyethylene, leather, polyethylene, leather, polyethylene.
11. Take the upper female gland & place on top of your assembled upper packings with the inverted side down. 
12. Take your assembled upper glands and packings (7 pieces) and slide on over the top of the piston, making sure the inverted sides are facing down.
13. Take the V-packing holder and replace the white O-ring and the black O-ring with new ones from the packing kit.
14. Slide the V-packing holder over the top of the upper packings so they fit inside.
15. Lubricate the inside of the fluid pump body and the outside of the packings with a light weight oil.
16. Slide the completed assembly into the fluid pump body.  
**\*NOTE: TO KEEP PACKINGS SECURED IN THE CORRECT POSITION, HOLD THE PUMP BODY UPSIDE DOWN AND PUSH THE COMPLETED ASSEMBLY UPWARDS INTO THE PUMP BODY. ONCE PLACED INSIDE, TILT THE PUMP BODY BACK UP TO KEEP ALL PIECES.**
17. Thread the packing nut into the top of the fluid body and tighten hand tight.
18. Take the suction retainer and replace the black O-ring with a new one from the packing kit. Replace the suction ball with the new one from the kit into the suction retainer. Place the suction seat into the flat side of the ball guide, over the suction ball. Now place the white O-ring into the groove around the suction seat.
19. Take the completed suction valve assembly and place it into the bottom of the fluid body, with the rounded side fitting inside.
20. Take the suction seat support and place the flat side down on to the suction valve assembly (threads will be facing upwards).
21. Thread the suction nut, over the suction seat support.
22. Tighten the packing nut (utilizing the packing nut adjustment tool) clockwise one full turn.

# PACKING REPLACEMENT PROCEDURES

**FIG. 21**

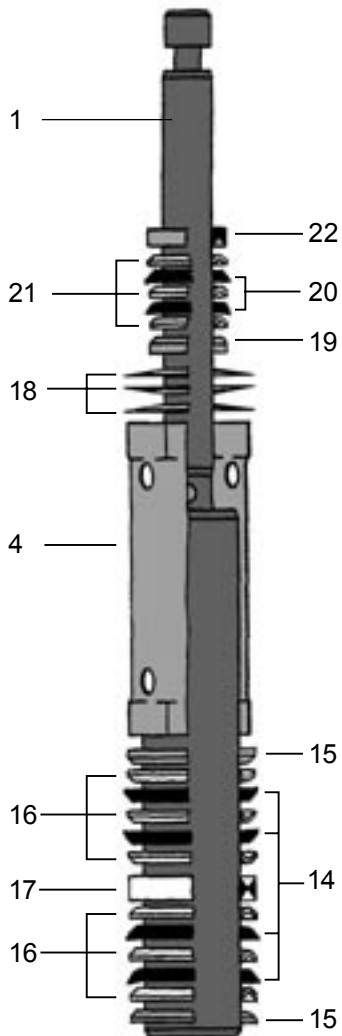

**FIG. 22**

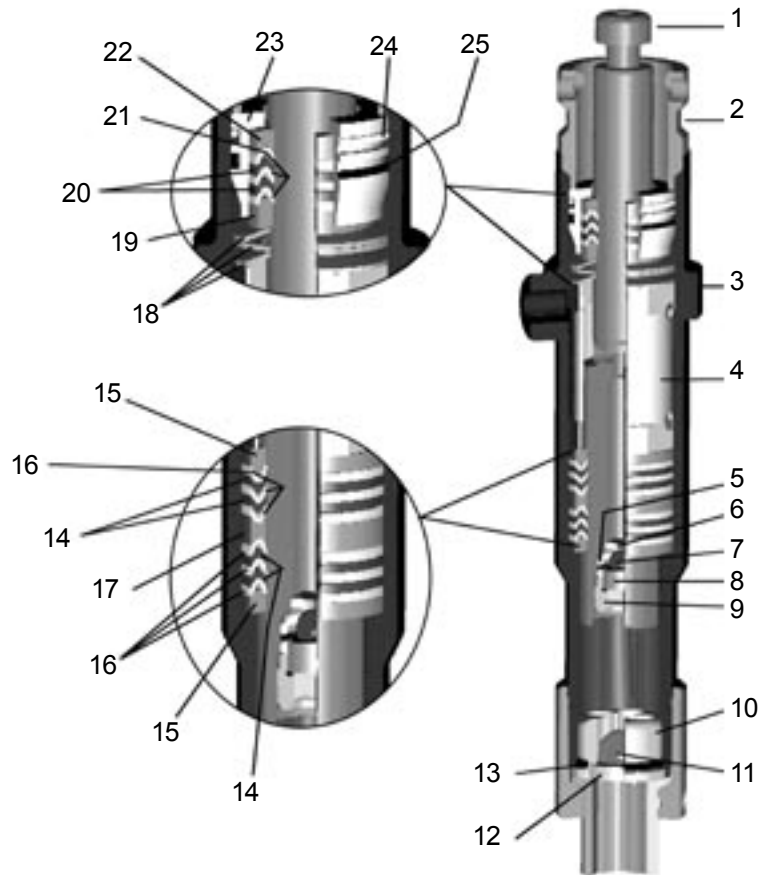

## PARTS LIST FIGURE 21 & 22

Item No.	Part No.	Description
1	187-330-99	Piston Rod
2	187-046	Packing Nut
3	187-313	Fluid Body
4	187-315	Spacer
5	106-021	O-Ring
6	187-062	Ball Guide
7	115-022	Outlet Ball
8	187-061	Outlet Seat
9	187-051	Outlet Seat Support
10	187-016	Suction Retainer
11	187-020	Suction Ball
12	187-065	Suction Seat
13	106-014	O-Ring

## PARTS LIST FIGURE 21 & 22 CONT

Item No.	Part No.	Description
14	187-059	Packing Leather
15	187-037	Male Gland
16	187-029	Packing Polyethylene
17	187-058	Female Adaptor
18	187-031	Belleville Springs
19	187-025	Male Gland
20	187-060	Packing Leather
21	187-030	Packing Polyethylene
22	187-026	Female Gland
23	187-047	Packing Holder
24	106-012	White O-Ring
25	106-013	Black O-Ring

# PAINT SYSTEM

FIG. 23

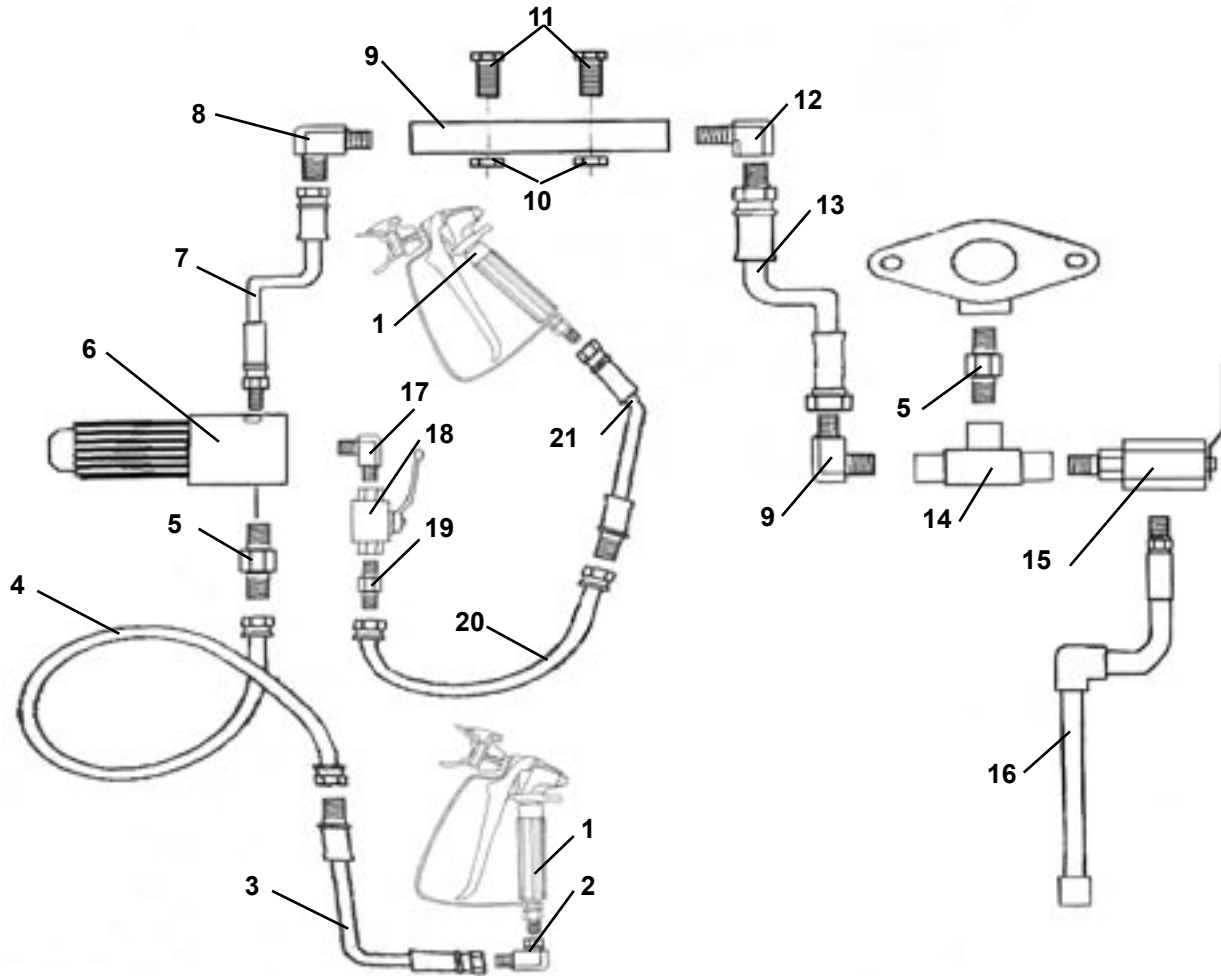

## PARTS LIST FIGURE 23

Item No.	Part No.	Description
1	120-554	008 Gun
2	100-177	Swivel Elbow 1/4"
3	100-011	Hose 50' x 1/4"
4	100-023	Hose 50' 3/8"
5	169-010	Nipple 3/8" M
6	111-200-99	Manifold Filter Assy
7	301-309	Hose 3/8"
8	167-016	Elbow 3/8" M
9	301-253	Manifold
10	100-317	Nut 1/4" M (2)
11	100-345	Bolt 1/4" (2)

## PARTS LIST FIGURE 23 CONT

Item No.	Part No.	Description
12	169-013	Elbow 3/8" M x 3/8" F
13	100-123	Hose 3/8"
14	100-036	Tee 3/8"
15	119-083	Prime Valve
16	119-086	Bypass Hose Assy
17	100-141	Elbow 1/4"
18	100-119	Ball Valve
19	115-019	Connector 1/4"
20	100-199	Hose 3/8" x 6'
21	100-204	Hose 1/4" x 5'

# PRIME VALVE (119-083)

FIG. 24

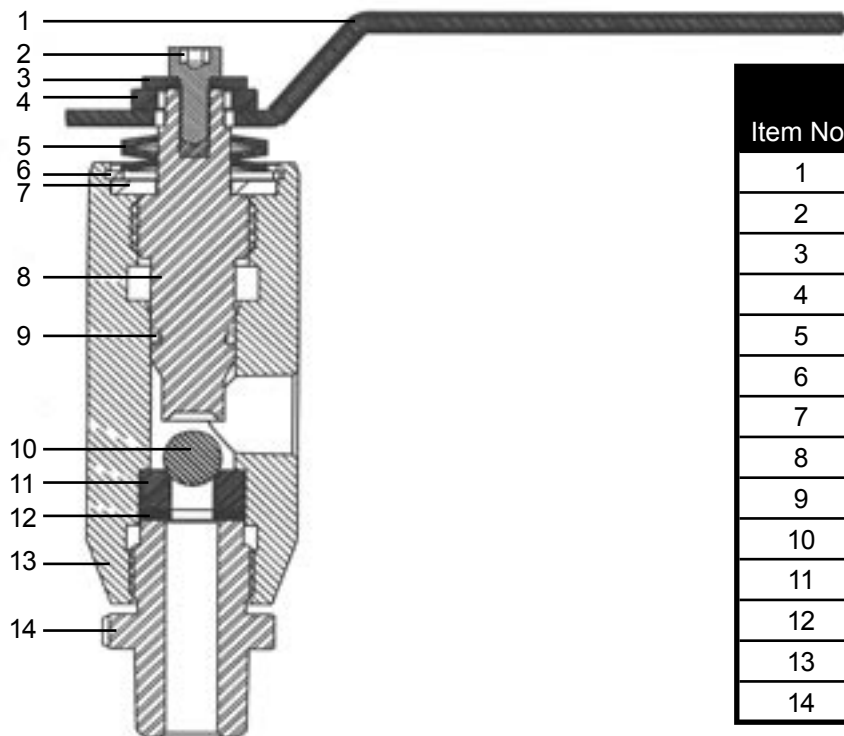

PARTS LIST FIGURE 24		
Item No.	Part No.	Description
1	115-303	Handle with Label
2	117-046	Screw
3	115-063	Washer
4	115-072	Spacer
5	115-064	Belleville Spring (3)
6	115-065	Retaining Ring
7	115-067	Washer
8	115-071	Valve Stem
9	115-068	O-Ring Black
10	115-069	Ball
11	115-029	Valve Seat
12	115-012	Washer
13	115-073	Valve Body
14	115-074	Inlet Fitting

# MANIFOLD FILTER (111-200-99)

FIG. 25

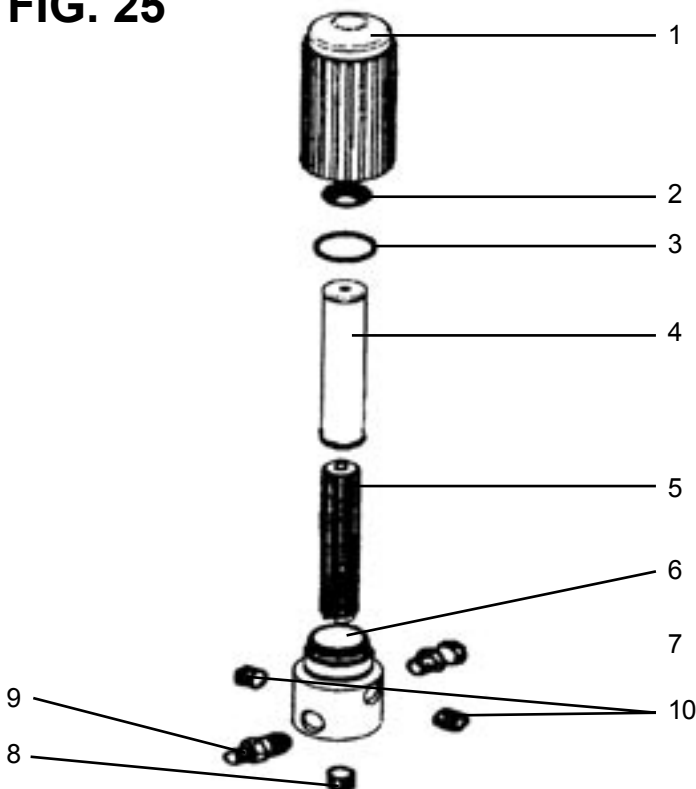

PARTS LIST FIGURE 25		
Item No.	Part No.	Description
1	111-202	Base
2	301-356	Spring
3	106-007	O-Ring
4	111-204	Filter 60 Mesh
5	111-203	Support
6	111-201	Base
7	100-159	Swivel
8	100-129	Plug 3/8" (2)
9	100-109	Nipple 3/8"M x 1/4"M
10	100-028	Plug 1/4"

# REPLACEMENT OF ELECTRICAL CONTROL BOARD

1. Remove electrical cover.
2. Disconnect sensor lead from Electrical Board.
3. Disconnect two clutch leads on Electrical Board from leads on clutch.
4. Using a 1/16" allen, loosen set screw in Pressure Control Knob and remove knob.
5. Using a 1/2" nutdriver or 1/2" deep socket, remove nut from pressure control shaft. This will allow removal of electrical control board from frame.
6. Replace Electrical Board Assembly in reverse order. Adjust pressure as per procedure below, "Pressure Calibration on the Electrical Control Board".

## PRESSURE CALIBRATION OF THE ELECTRICAL CONTROL BOARD

1. Turn "Pressure Calibration" Trimpot adjustment on electrical control board in the counter clockwise direction at least 15 revolutions.
2. Connect 5000 psi glycerine pressure guage on outlet of pump between fluid pump & airless hose to monitor Fluid Pump Pressure.
3. Start engine and run at maximum RPM. Turn Prime Valve to the open (Prime) position. Turn Pressure Control Knob to maximum position (fully clockwise).

4. Using an insulated screwdriver, adjust "Pressure Calibration" Trimpot by turning clockwise until the clutch engages. When the clutch engages the pump will commence Priming. When pump is primed, turn the Prime Valve to the Closed (Pressure) Position.

**THE PUMP WILL BEGIN TO PRESSURIZE AND THE CLUTCH WILL DISENGAGE AT A LOW PRESSURE. CONTINUE TURNING THE TRIMPOT CLOCKWISE TO INCREASE PRESSURE TO 3000 PSI.**

5. Trigger gun. The pressure should drop approximately 350-400 psi, the clutch will engage and build pressure to 3000 psi and disengage. Trigger gun several times to ensure proper pressure setting.
6. Turn Pressure Control Knob to minimum position. The clutch should disengage and pump stop moving.
7. Secure leads with tie strap.
8. Replace cover on unit. Ensure the leads are not pinched or damaged in the process of replacing covers.

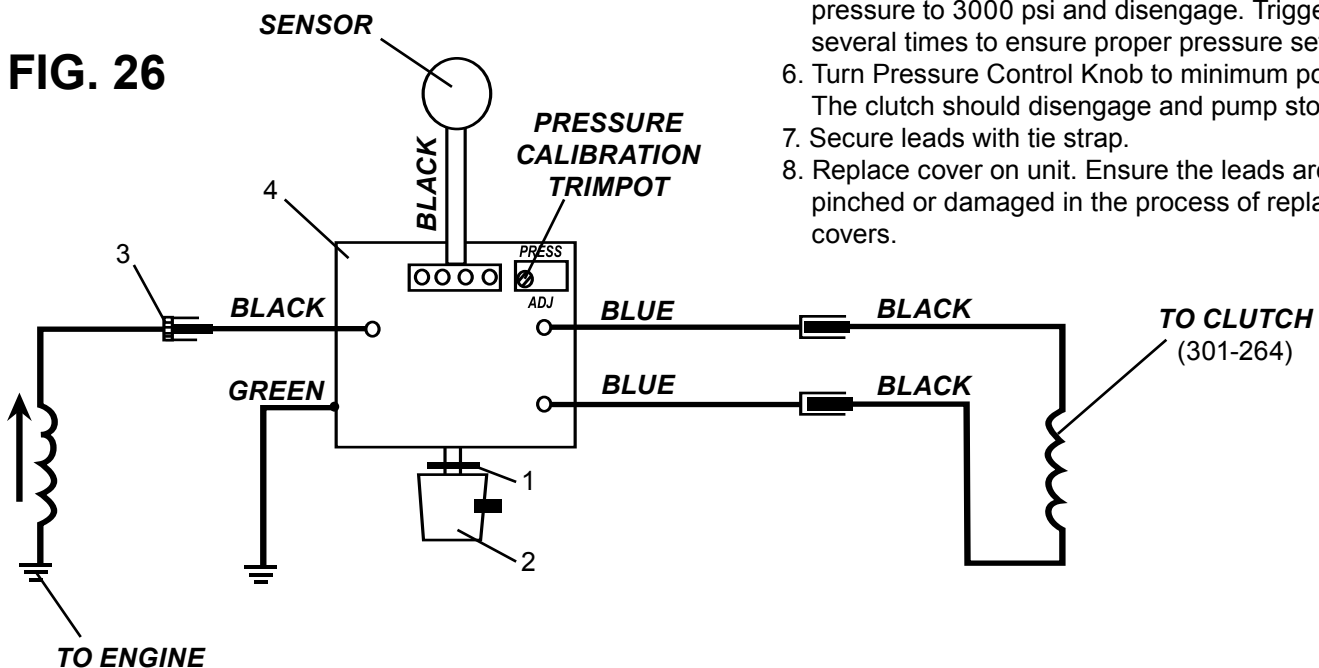

### PARTS LIST FIGURE 26

Item No.	Part No.	Description
1	106-019	O-Ring
2	301-523A	Knob
3	117-045	Grommet
4	301-282-99	Control Board



# ELECTRICAL TROUBLESHOOTING - Clutch Does Not Engage

**STEP 1:** Ensure that the pressure control knob (POT) is in the maximum (CW) position.

**STEP 2:** Remove the upper and lower clutch and electrical covers.

**STEP 3:** Check all electrical connections between the engine magneto, sensor, control board and clutch for loose connections or damaged leads. See Fig.26.

**STEP 4:** Disconnect the two leads from the control board (blue) and the clutch assembly (black). Using a multimeter, with the engine at maximum RPM, pressure control knob in the maximum position and the prime valve open (priming) position, test the DC voltage across the boards leads (blue). This voltage must be 13-14 VDC. If the readings are correct, the board, sensor and magneto are okay and the problem is the clutch assembly. If this is the case, proceed to Step 5. If the voltage is outside this range go to Step 7.

**STEP 5:** Measure resistance between the clutch leads (black). This value must be 10-16 ohms. If this reading is out of specifications the clutch is defective and must be replaced, otherwise continue troubleshooting.

**STEP 6:** If the clutch resistance readings of Step 5 are correct, check spacing between the clutch field and plate. The gap should be .012" to .024". If the gap is greater than .024 the gap is too wide. If this gap is too wide, remove the spacer (Fig. 28, Item 7) from the clutch assembly. Should the clutch still not engage, replace the clutch assembly. See below.

**STEP 7:** When the DC voltage from the board is not 13-14 VDC, disconnect the control board lead (black) from the engine magneto lead (pink), located on the side of the engine. With the engine at maximum RPM, pressure control knob in maximum (CW) position and prime valve open (priming), read the AC voltage from the magneto lead to the sprayer frame. This reading should be 19-24 VAC. If outside this range, contact your local Honda repair facility for magneto replacement. If the magneto is producing the proper AC voltage, continue to Step 8.

**STEP 8:** Test the sensor by reading the resistance between the red and black wires. The resistance runs between 1.5-3 kohms. A defective sensor usually shows no resistance (open). If the reading is outside standards, replace the sensor. An alternative method to test the sensor, is to plug a new sensor into the board and see if the clutch will engage. Caution! When using this method, ensure prime/pressure valve is in the prime position. This is important because the sensor plugged into the board is not measuring pressure in the fluid section.

**STEP 9:** When Steps 7 & 8 have been completed and the magneto and sensor check good, the electrical control board is the only item left, replace the board. See page 22.

# CLUTCH REPLACEMENT

## REMOVING THE CLUTCH

### REFER TO FIGURES 26-30

1. Remove the gear box cover (Fig 30, item 1) by disconnecting fluid hose to the manifold filter and by unscrewing the four allen head bolts (Fig 30, item 36).
2. Disconnect the fluid pump as described on page 16.
3. Pull off the spacer tubes (Fig 30, item 30) and drop the sleeve bearing down and off. Slide the connecting rod off the gear box.
4. Remove the top cover (Fig 30, item 2) by unscrewing the 6 mounting screws. be careful not to lose the 6 matching grommets.
5. Remove the bottom cover (Fig 30, item 14) by unscrewing the 2 bolts and nuts.
6. Remove the splash cover (Fig 30, item 12) from the clutch brackets and spacer tubes.
7. Disconnect the two clutch leads from the electrical control board leads and the clutch spring (Fig 28, item 9) from the spacer tube.
8. Loosen (do not remove completely) the block tensioner's set screws (Fig 27, item 6) to detension the belt.
9. Loosen (do not remove yet) the four plate bolts.
10. Pull the cog belt loose from the engine shaft cog pulley and let hang loose on the clutch cog pulley.
11. Remove the two vertical bracket screws (Fig 30, item 20).
12. Remove the four horizontal screws through the gearbox plate (Fig 27, item 5) and lift the gear box off the machine.
13. Place gearbox in vice by gripping the flat part of the drive crank allowing the clutch assembly to face up. Use caution and not allow gearbox to swing and damage casting against vice.
14. Hold coupling screw, with 13/16" wrench, then with 5/16" allen wrench, screw differential screw out of coupling screw and gearbox shaft.
15. Remove the coupling screw from the clutch bore.  
**NOTE: AFTER EXTENDED USE THE COUPLING SCREW CAN HANG UP INSIDE OF THE CLUTCH BORE. TAPPING ON THE SIDE OF THE COUPLING SCREW AND/OR THE USE OF A LIGHTWEIGHT OIL OR BREAK FREE PRODUCT CAN EASE THE REMOVAL PROCESS. IN EXTREME CASES, SCREW THE DIFFERENTIAL SCREW LARGE THREAD SIZE IN, THEN PLACE A WASHER AND NUT ON THE SMALL THREAD SIDE. THIS ALLOWS THE PULLING OR PRYING ON THE COUPLING SCREW IN ORDER TO REMOVE IT.**
11. The clutch and other components can now be slide off the gear box shaft.

# CLUTCH REPLACEMENT

## INSPECTING THE CLUTCH

1. Inspect clutch and belt, replace as necessary.

## INSTALLING THE CLUTCH

### REFER TO FIGURES 27-30

1. With gearbox held in a vice vertically as previously described, place first spacer, and bearing, onto gearbox shaft. See Fig. 28
2. Insert snap rings (2), into recesses of cog pulley portion of clutch. Place cog pulley portion of clutch with cog belt attached onto shaft.
3. Place second spacer, into cog pulley portion of clutch. This spacer will rest on the first bearing, installed.
4. Insert second bearing, on top of upper snap ring,
5. Lay removable spacer on top of last bearing. If the clutch air gap is larger than .024", do not use removable spacer. Put spacer over removable spacer, if used, and top bearing.
6. Place coil portion of clutch down onto cog pulley portion of clutch and center on gearbox shaft.
7. Screw differential screw, into coupling screw and nut until 1/16" is showing. See Fig. 28
8. Push coupling nut assembly, into clutch assembly until it comes to a positive stop. (Differential screw comes into contact with the threaded gearbox shaft.)
9. With 13/16" wrench on coupling screw and 5/16" allen wrench in differential screw, simultaneously with both wrenches screw coupling nut assembly into gearbox shaft by turning clockwise until a positive stop is reached.
10. Hold coupling nut ass'y and tighten differential screw to 30 ft.-lbs. This will expand the coupling assembly, thereby holding the clutch assembly to gearbox shaft. Turn clutch observing clutch gap. The pulley should turn freely with a gap of .012 to .024" between the two clutch faces. If the gap is greater than .024, remove the removable spacer. Reassemble and check gap for proper clearance.
11. Place cog belt over cog pulley portion of clutch. Set gearbox and clutch assembly on the support brackets (Fig 30, items 25 & 26), screw in the two vertical bracket screws (Fig 30, item 20) and start the four horizontal screws through the gearbox plate (Fig 27, item 5) and into the back of the gearbox.
12. Slide cog belt over engine pulley

## BELT TENSIONING

13. Slightly loosen the two horizontal screws (Fig 31, items 19-22) that connect the top and bottom supports (Fig 31, items 24 & 25).
14. Evenly tighten set screws (Fig 27, item 6) until flush with tip of block tensioner (Fig 27, item 7) . Check tension on cog belt by pressing hard with thumb. Proper tensioning should allow for approximately 1/8". If belt is too loose, tighten set screws further.
15. Once belt tension is correct tighten down the four horizontal screws that go through the gearbox plate (Fig 30, item 8) and into the back of the gearbox. Also tighten the two horizontal screws (Fig 31, items 19-20) that connect the top and bottom supports (Fig 31, items 24 & 25). Reconfirm that the belt deflection is still 1/8".
15. Reassembly connections, covers and fluid pump in reverse order as described in steps 1-7 of the "Removing Clutch" instructions.

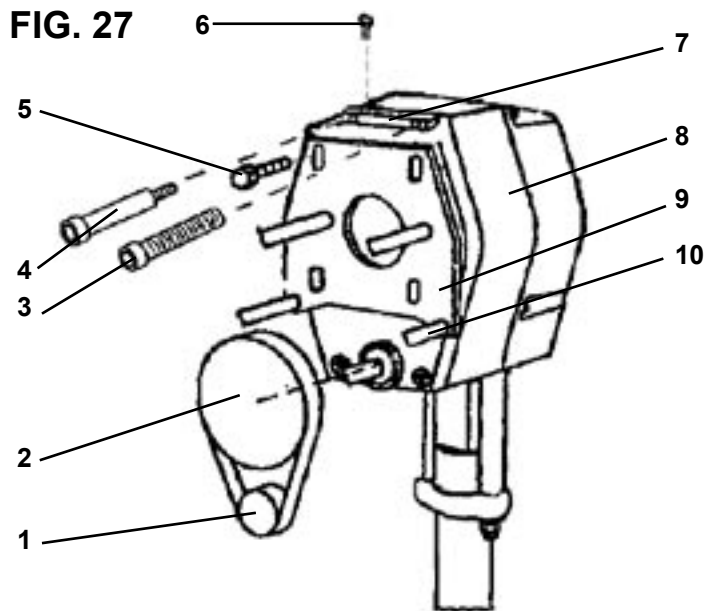

FIG. 27

### PARTS LIST FIGURE 27

Item No.	Part No.	Description
1	301-231	Cog Belt
2	301-284	Clutch Replacement
3	305-088	Screw
4	100-175	Shoulder Screw
5	100-173	Screw Flanged (4)
6	100-174	Set Screw (2)
7	301-534	Block Tensioner
8	301-208	Gearbox
9	305-045	Plate
10	305-046	Spacer Tube

# CLUTCH ASSEMBLY

FIG. 28

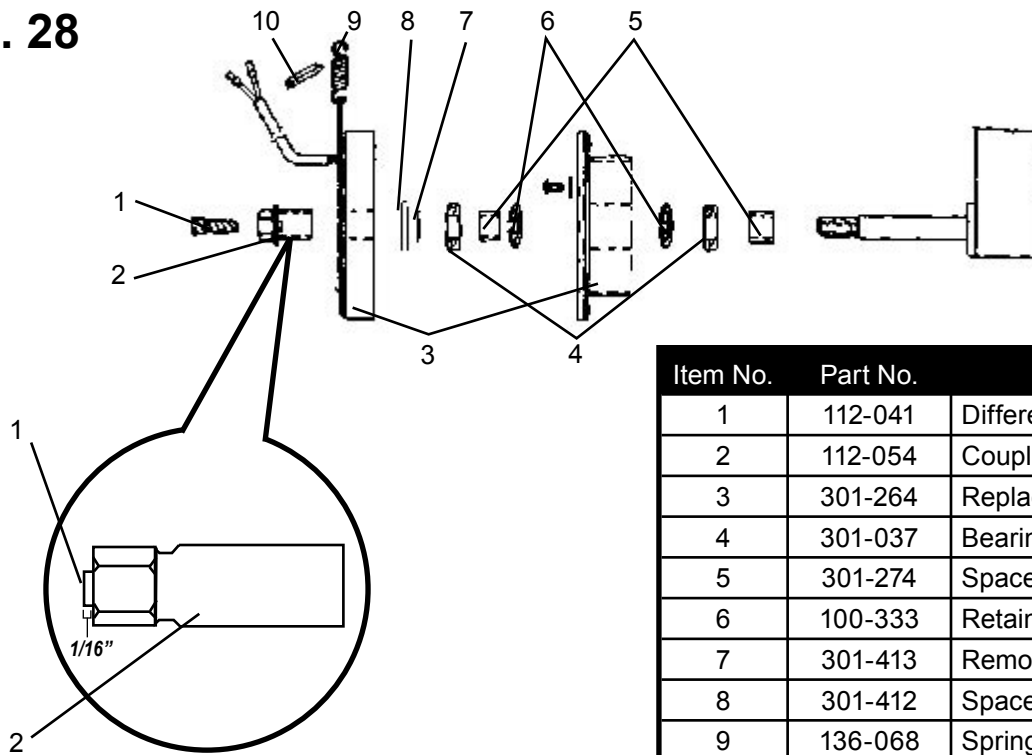
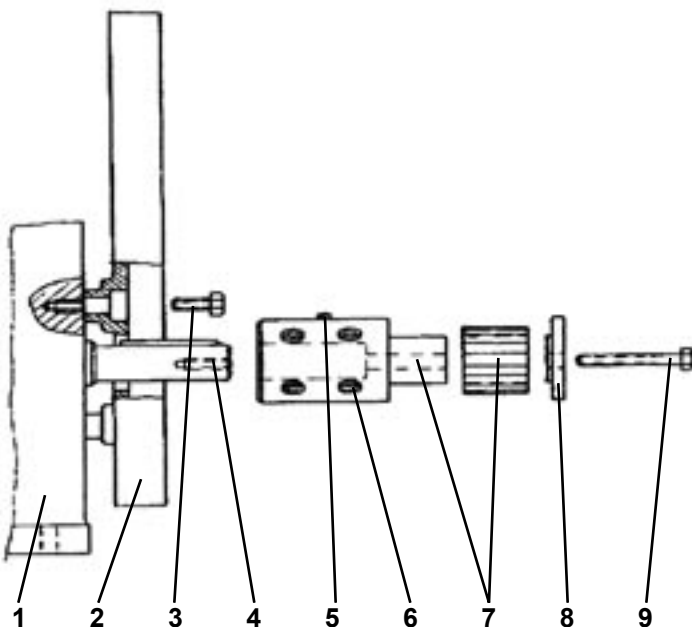

FIGURE 28

Item No.	Part No.	Description
1	112-041	Differential Screw
2	112-054	Coupling Nut Assy
3	301-264	Replacement Clutch
4	301-037	Bearing (2)
5	301-274	Spacer (2)
6	100-333	Retaining Ring (2)
7	301-413	Removable Spacer
8	301-412	Spacer
9	136-068	Spring
10	301-316	Rubber Edge

# ENGINE ASSEMBLY

FIG. 29



PARTS LIST FIGURE 29

Item No.	Part No.	Description
1	301-160	Honda GX160 Engine
2	305-012	Adaptor
3	136-091	Screw (4)
4	112-029	Key
5	100-357	Set Screw
6	100-383	Screw (4)
7	301-222A	Sheave Assy
8	301-229	Thrust Plate
9	301-230	Screw

# POWER UNIT ASSEMBLY

**FIG. 30**

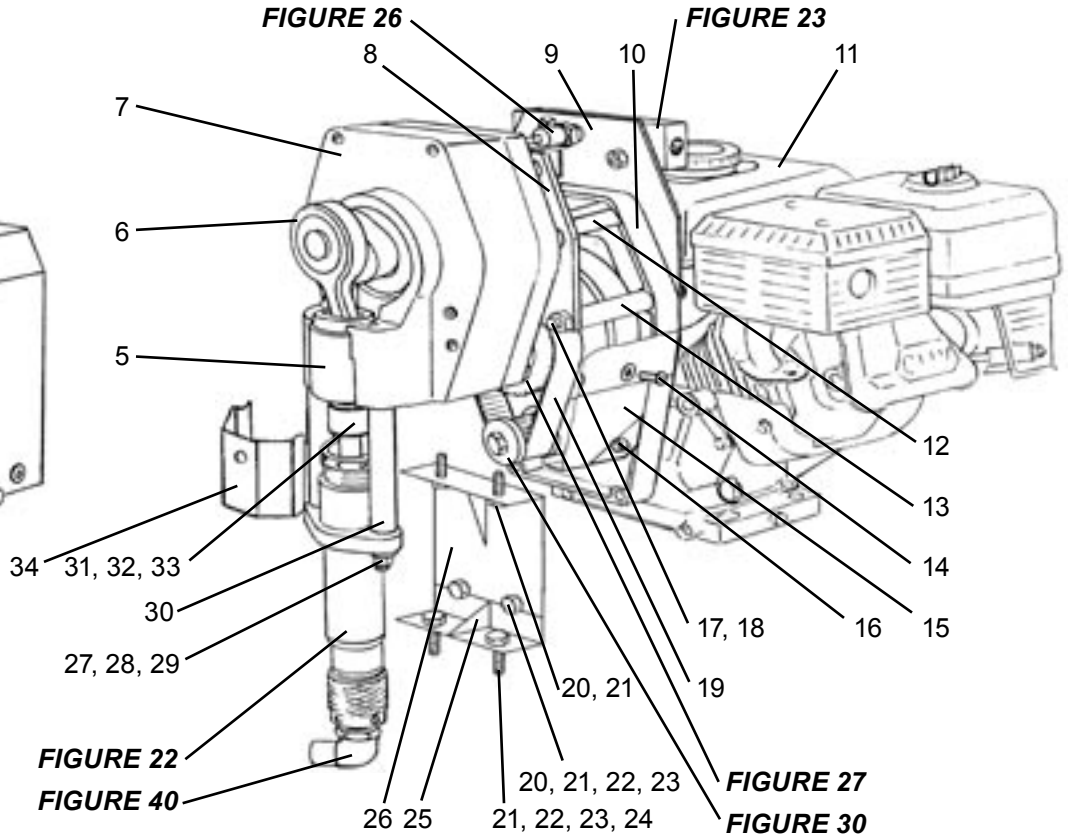
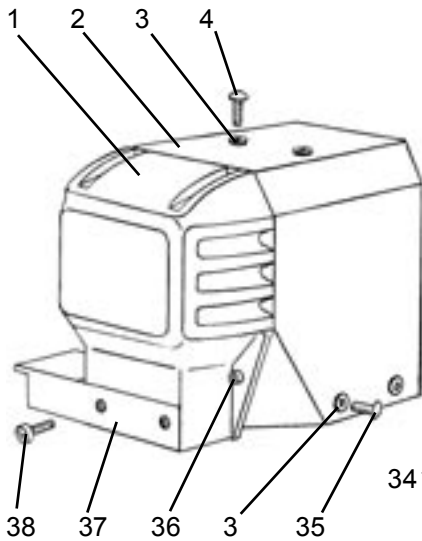

PARTS LIST FIGURE 30		
Item No.	Part No.	Description
1	301-320	Gearbox Cover
2	301-531	Top Cover
3	301-135	Grommet (6)
4	301-337	Screw (2)
5	301-047	Sleeve Bearing
6	301-333	Connection Rod
7	301-208	Gearbox
8	305-045	Gearbox Mounting Plate
9	305-064	Manifold Holder
10	305-012	Adapter
11	301-160	Honda GX160 Engine
12	301-529	Splash Cover
13	305-046	Tube Spacer (4)
14	136-091	Screw (2)
15	305-067	Bottom Cover
16	100-345	Screw (2)
17	305-047	Stud (4)
18	140-044	Nut (8)
19	301-231	Cog Belt
20	111-044	Screw (4)

PARTS LIST FIGURE 30 CONT		
Item No.	Part No.	Description
21	140-029	Washer (10)
22	113-023	Washer (4)
23	100-317	Nut (4)
24	169-050	Screw (2)
25	301-299	Bottom Support
26	301-232	Top Support
27	100-328	Stud (2)
28	140-035	Washer (2)
29	140-051	Nut (2)
30	301-059	Spacer (2)
31	189-047	Coupling Set Cover
32	189-046	Coupling Set
33	189-048	Retainign Rings
34	301-467	Shield
35	111-037	Screw (4)
36	100-312	Screw (4)
37	305-140	Manifold Filter Bracket
38	100-360	Screw (2)
*	188-160	Grounding Assy

# FIRST GUN ASSEMBLY - 305-167(4550) 305-391(6050)

**FIG. 31**

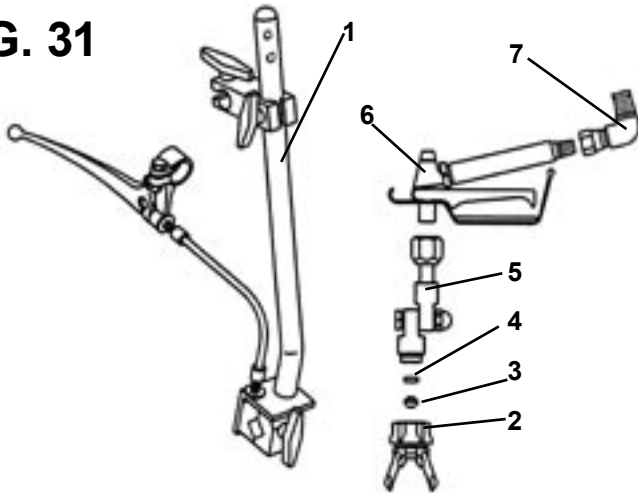

PARTS LIST FIGURE 31		
Item No.	Part No.	Description
1	305-150	Gun Holder (4050)
	305-393	Gun Holder (6050)
2	561-002	RevGuard (G Thread)
3*	561-025	Seal-Metal
4*	561-026	Seal-Plastic
5	032-028	Swivel Assembly
6	120-554	008 Airless Gun
7	100-177	Elbow

# SECOND GUN ASSEMBLY - 305-176(4550) 305-392(6050)

**FIG. 32**

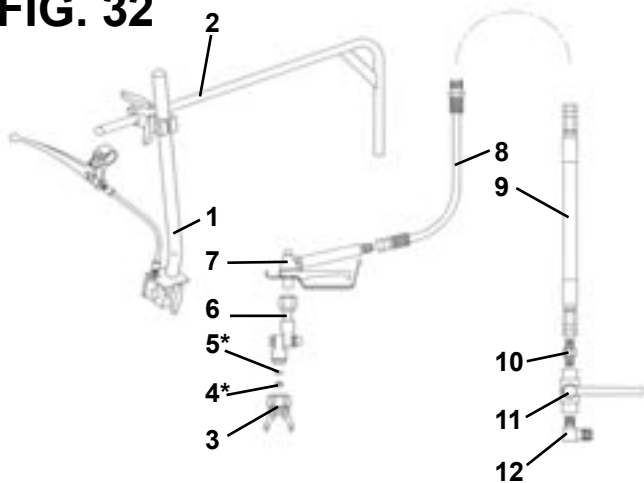

PARTS LIST FIGURE 32		
Item No.	Part No.	Description
1	305-146	Gun Holder (4550)
	305-393	Gun Holder (6050)
2	305-076	Gun Arm (Long)
3	561-002	RevGuard (G Thread)
4	561-025*	Metal Seal
5	561-026*	Plastic Seal
6	032-028	Swivel Assy
7	120-554	008 Airless Gun
8	100-204	Hose 1/4" x 5'
9	100-199	Hose 3/8" x 6'
10	115-019	Connector
11	100-119	Ball Valve
12	100-141	Elbow

# BALL VALVE (100-119)

**FIG. 33**

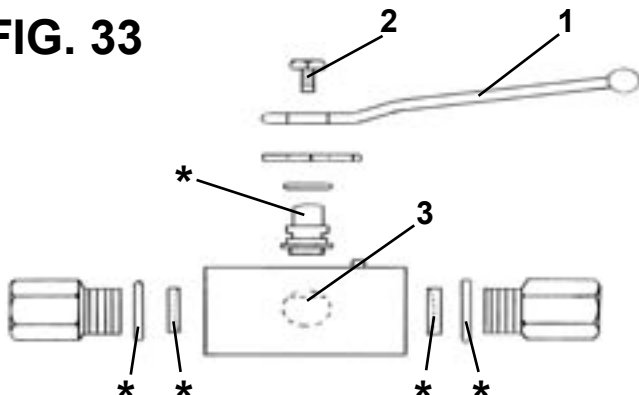

PARTS LIST FIGURE 33		
Item No.	Part No.	Description
1	100-162	Handle
2	100-163	Screw
*	Kit-119	Rebuild Kit

**GUN HOLDER ASSEMBLY - 305-150(SS4550 - 1ST GUN) 305-146(SS4550 - 2ND GUN)  
305-393(SS6050 - BOTH GUNS)**

**FIG. 34**

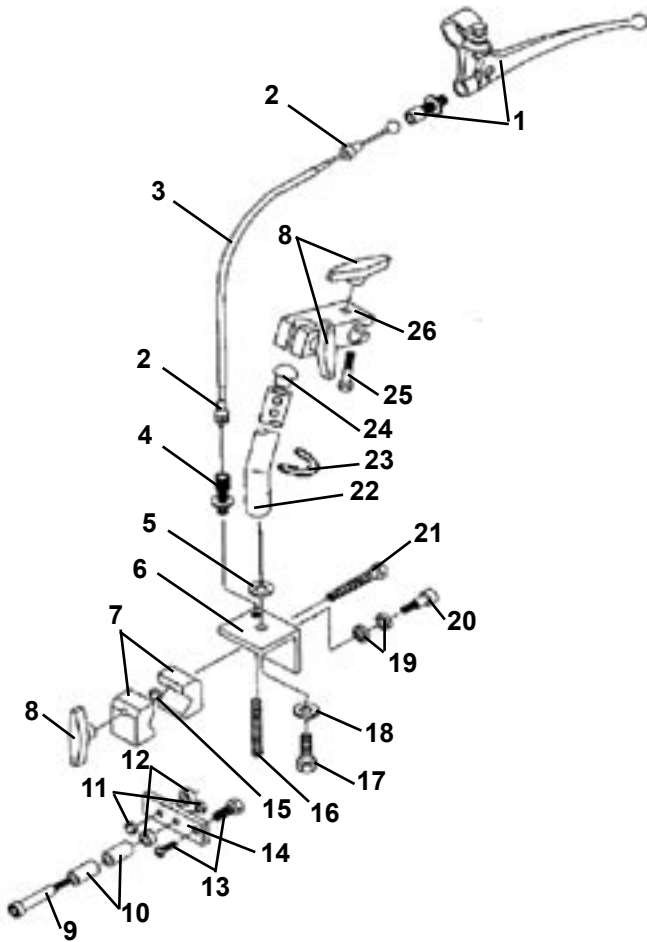

**PARTS LIST FIGURE 34**

Item No.	Part No.	Description
1	305-142	Lever Assy.
2	305-089	Cable Insert (2)
3	305-077 100-685	Gun Cable Assy. (4550) Gun Cable Assy. (6050)
4	305-141	Cable Adjuster
5	111-052	Tube Connector
6	305-154	Bracket
7	305-152	Clamp (2)
8	305-157	Knob (3)
9	100-342	Screw
10	305-159	Sleeve Bearing (2)
11	140-045	Jam Nut (2)
12	305-161	Spacer (2)
13	305-079	Wire Swivel Assy.
14	305-155	Lever
15	140-051	Nut
16	116-100	Spring
17	169-050	Screw
18	113-027	Lock Washer
19	305-156	Thrust Washer (2)
20	305-158	Shoulder Screw
21	100-673	Screw
22	305-153 305-297	GS Holder (2nd Gun-4550) GS Holder (6050,1st Gun-4550)
23	116-105	Spring Clip (1st Gun, 4550 only)
24	143-027	Ball Guide
25	171-008	Screw (2)
26	136-019P	Swivel Clam Assy.

# SWIVEL WHEEL ASSEMBLY - 4550

FIG. 35

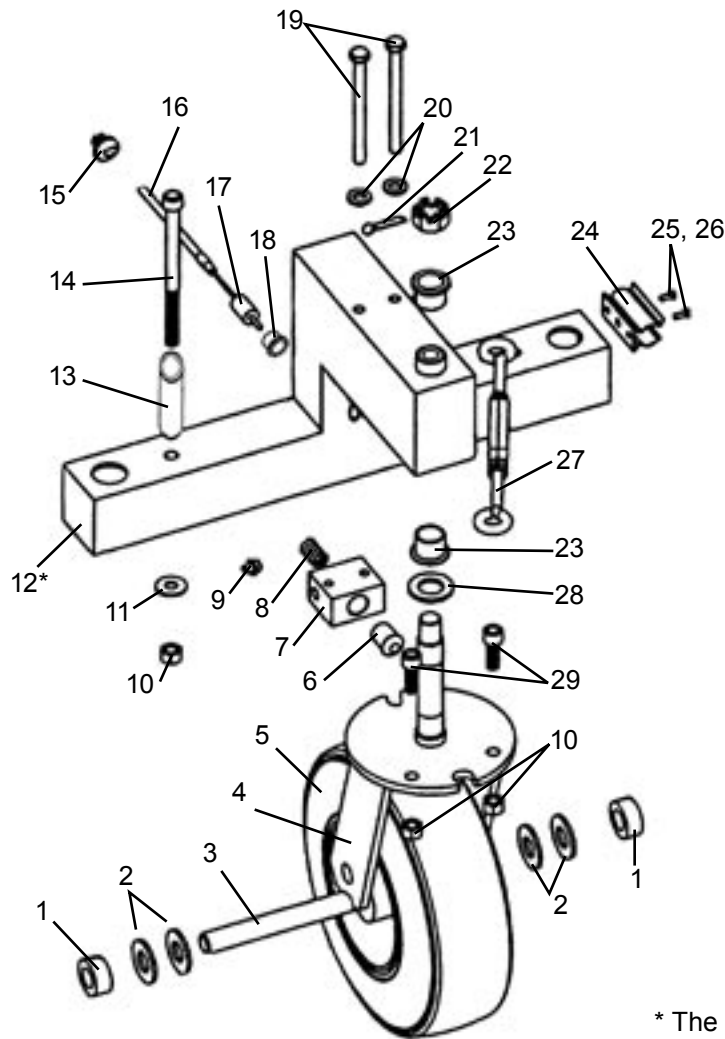

\* The swivel wheel weldment is part of the entire stripper frame weldment.

## PARTS LIST FIGURE 35

Item No.	Part No.	Description
1	143-029	Set Collar (2)
2	143-028	Washer (4)
3	136-230	Axel
4	305-253	Swivel Clamp
5	139-337A	Wheel
6	305-257	Swivlel Lock Pin
7	305-258	Swivel Lock
8	136-223	Spring
9	100-223	Grease Fitting
10	119-035	Nut (4)
11	100-344	Washer (2)
*12	305-395	Frame Weldment
13	179-029	Spacer (2)
14	100-648	Screw (2)
15	305-261	Cabel Holder

## PARTS LIST FIGURE 35 CONT

Item No.	Part No.	Description
16	100-652	Cable
17	305-259	Lock End Lug
18	305-141	Cable Adjustor
19	100-318	Screw (2)
20	113-023	Washer (2)
21	113-021	Cotter Pin
22	260-029	Hex Castle Nut
23	112-008	Flanged Bearing (2)
24	111-036	Spring Clamp
25	140-040	Washer (2)
26	117-072	Screw (2)
27	136-231	Turnbuckle
28	140-053	Washer
29	100-649	Screw (2)

# FRAME ASSEMBLY - 4550 (305-411)

FIG. 36

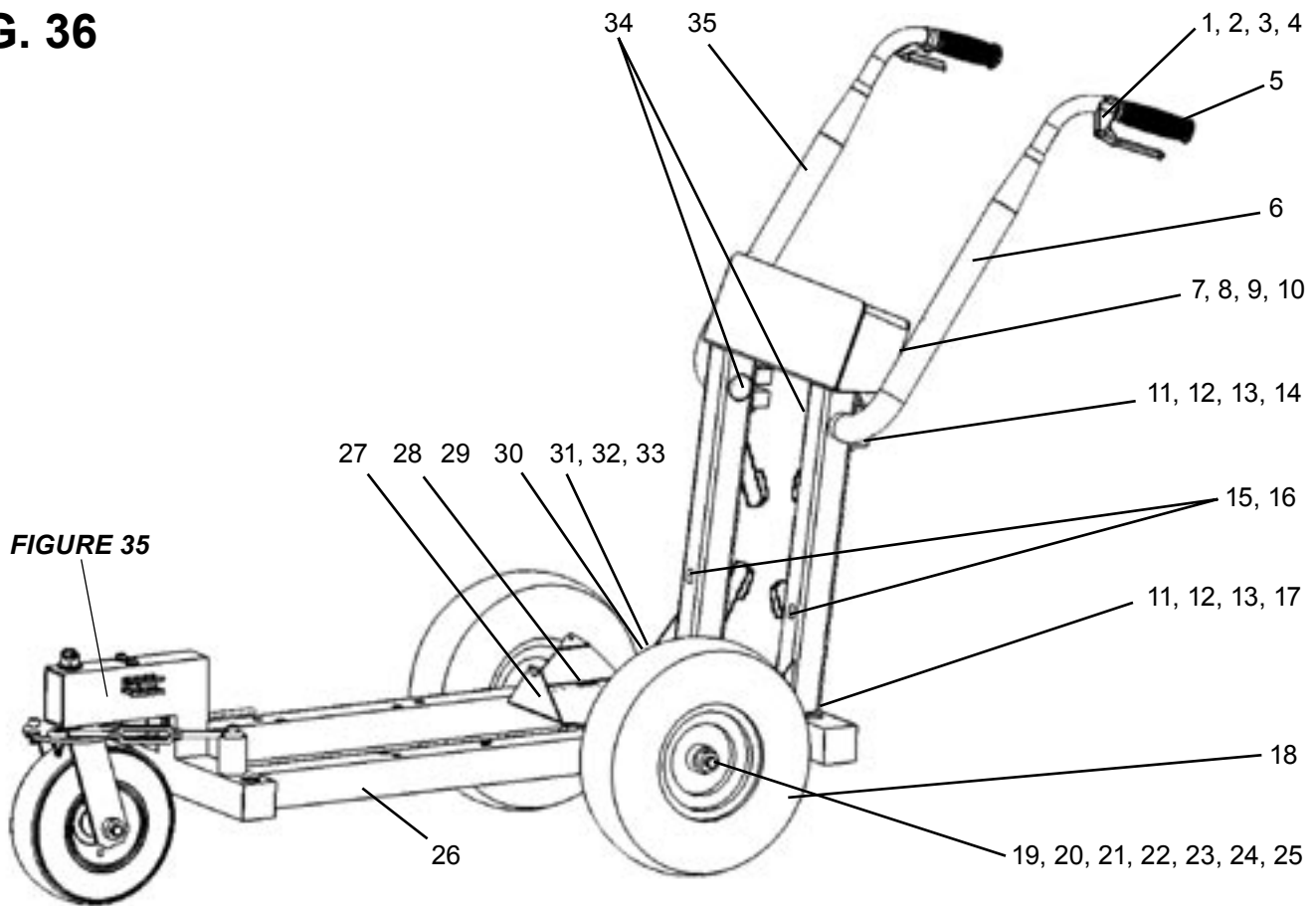

## PARTS LIST FIGURE 36

Item No.	Part No.	Description
1	136-023	Cable End Lug
2	301-335	Shrink Tubing (2)
3	305-089	Cable Insert
4	305-105	Lever
5	305-058	Rubber Grip (2)
6	305-314	Handle Weldment (Left)
7	113-022	Nut (2)
8	100-686	Paint Hose Hook (4)
9	100-344	Washer (4)
10	100-360	Screw (4)
11	100-696	Nut (2)
12	140-034	Washer (2)
13	140-035	Washer (2)
14	100-695	Screw (2)
15	100-687	Two Channel Strap (3)
16	100-688	Screw (3)
17	139-327	Rivnut (2)
18	301-166	13" Wheel

## PARTS LIST FIGURE 36 CONT

Item No.	Part No.	Description
19	188-367	Axle
20	100-369	Wave Washer (2)
21	113-030	Spacer (2)
22	136-131	Chain Sash
23	136-133	Key Ring
24	143-029	Set Collar (2)
25	143-028	Washer (2)
26	305-395	Frame
27	305-396	Bucket Base
28	119-026	Screw (3)
29	305-428	Stop
30	100-621	Cap
31	188-042	Lock Nut (4)
32	305-185	Brake Clamp
33	100-390	Screw (4)
34	100-601	Plug (2)
35	305-315	Handle Weldment (Right)



# SWIVEL LOCK ASSY - 6050 (305-390)

FIG. 37

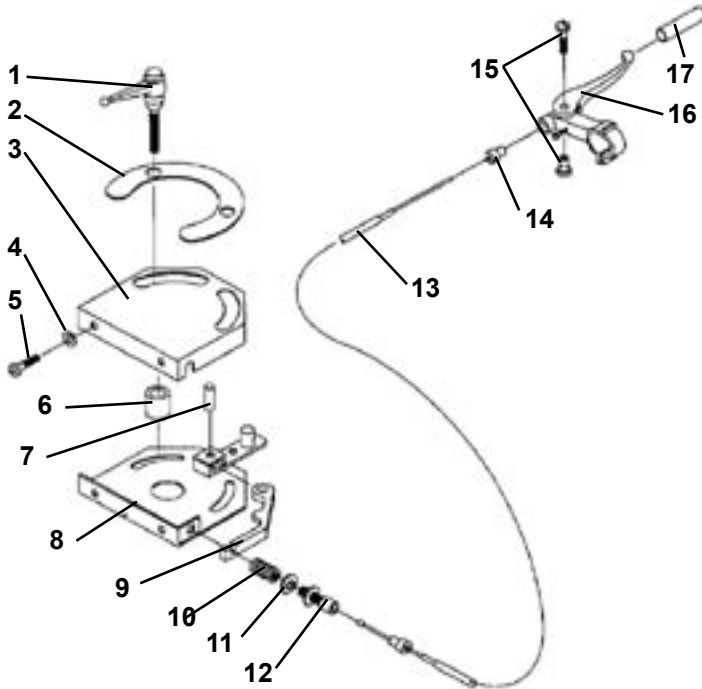

305-105PARTS LIST FIGURE 37

Item No.	Part No.	Description
1	305-020	Adjustable Handle (2)
2	305-091	Seal
3	305-049	Cover-Lock
4	140-042	Washer (3)
5	331-138	Screw (3)
6	305-027	Spacer (2)
7	119-028R	Dowel Pin
8	305-031	Base Lock Weldment
9	305-081	Lever
10	305-032	Spring
11	119-019	Washer (2)
12	305-032	Cable Adjuster
13	100-684	Cable Assy Swivel
14	305-089	Cable Insert
15	136-023	Cable End Lug
16	305-105	Lever
17	301-335	Heat Shrink

# SWIVEL WHEEL ASSY - 6050 (305-022)

FIG. 38

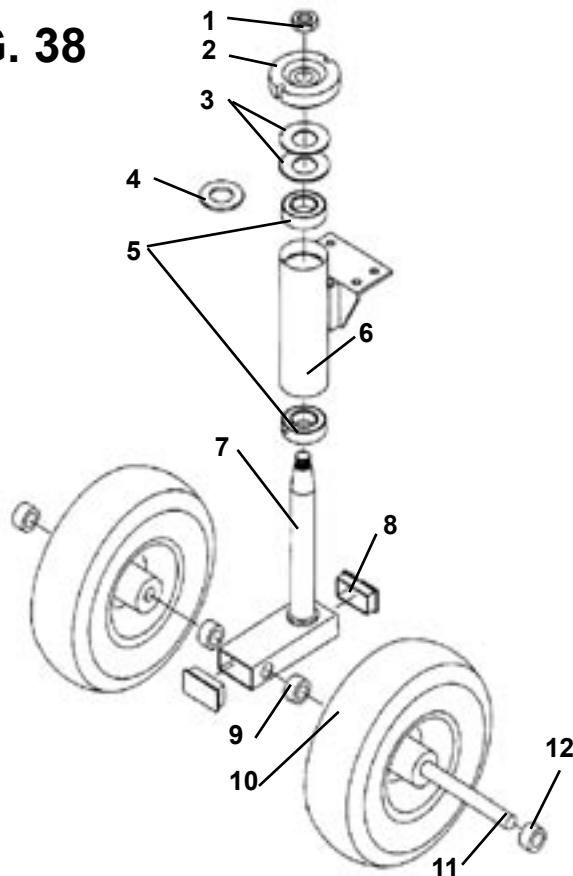

PARTS LIST FIGURE 38

Item No.	Part No.	Description
1	301-227	Jam Nut
2	305-025	Swivel Lock
3	305-028	Belleville Springs (2)
4	305-179	Shim
5	301-036	Bearing (2)
6	305-023	Swivel Body
7	305-024	King Pin
8	305-037	Plug (2)
9	113-030	Spacer (2)
10	139-337A	Wheel (2)
11	305-038	Axle
12	143-029	Set Collar (2)

# FRAME ASSEMBLY - 6050

**FIG. 39**

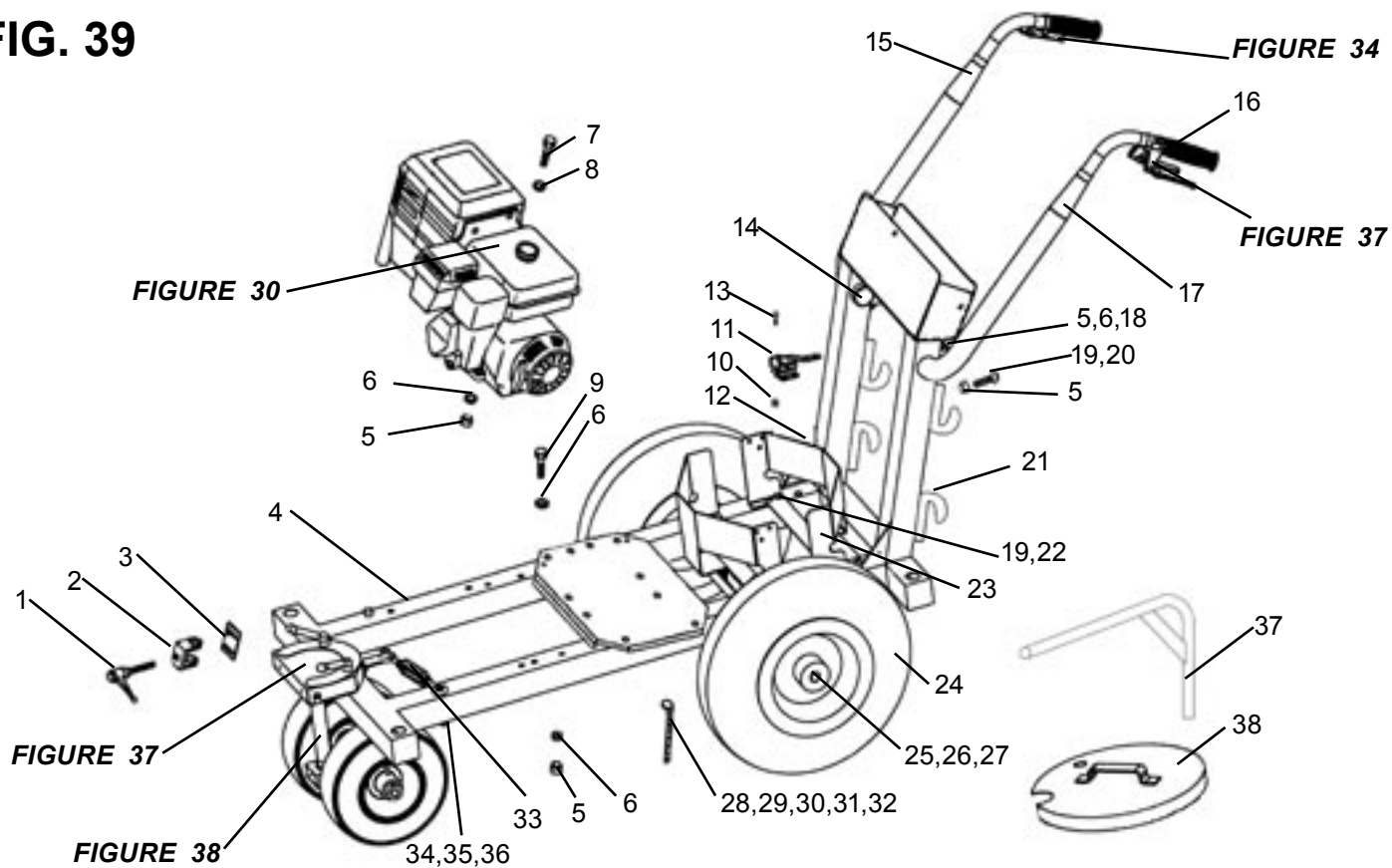

PARTS LIST FIGURE 39		
Item No.	Part No.	Description
1	305-044	Adjustable Handle
2	305-051M	Clamp
3	305-108	Plate
4	305-050	Frame Weldment
5	113-022	Nut (16)
6	113-023	Washer
7	136-123	Screw (4)
8	140-029	Washer (4)
9	301-547	Screw (4)
10	188-042	Nut (4)
11	305-185	Brake Assy
12	100-621	Cap
13	100-390	Screw (4)
14	100-601	Plug (2)
15	305-315	Right Handle
16	305-058	Rubber Grips (2)
17	305-314	Left Handle
18	301-547	Screw (2)
19	100-360	Screw (4)
20	100-344	Washer (4)

PARTS LIST FIGURE 39 CONT		
Item No.	Part No.	Description
21	100-686	Hook (4)
22	111-044	Screw (4)
23	305-144	Bucket Holder (2)
24	305-056	Wheel (2)
25	305-052	Axle
26	305-054	Cotter Pin (2)
27	305-055	Nut (2)
28	136-197	Terminal Ring
29	136-133	Key Ring
30	136-132R	Chain 10"
31	171-009	Screw
32	188-042	Washer
33	136-231	Turnbuckle
34	140-051	Nut
35	100-678	Screw
36	140-035	Washer
37	139-353	Gun Arm (Short - 1 Gun)
	305-076	Gun Arm (Long - 2 Gun)
38	301-533	Bucket Lid

# SUCTION ASSEMBLY (301-594)

**FIG. 40**

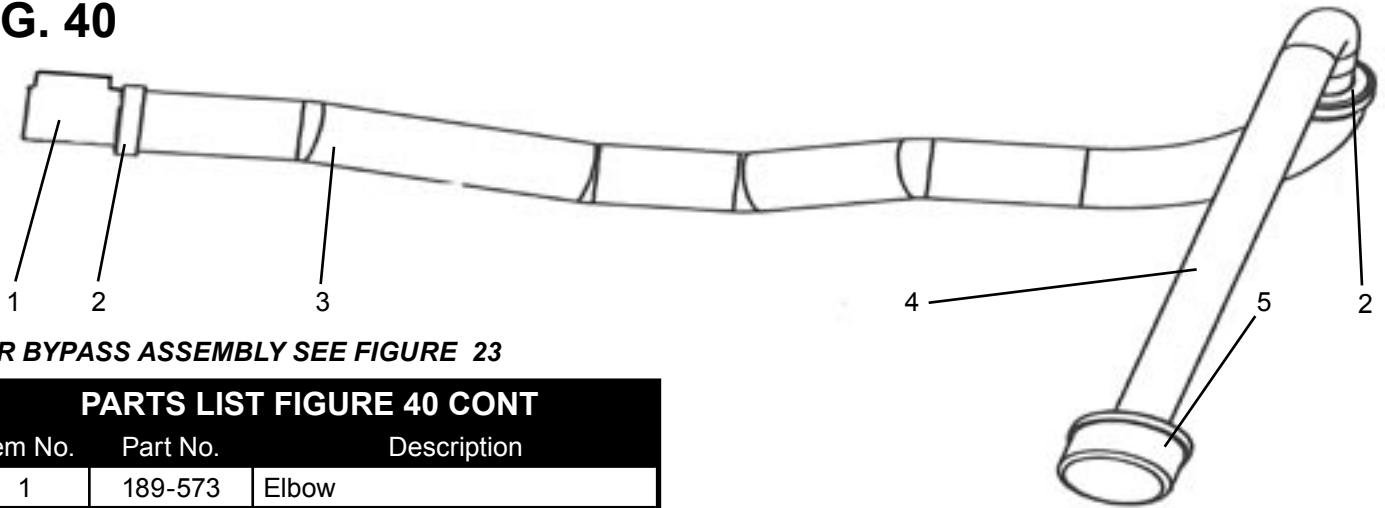

FOR BYPASS ASSEMBLY SEE FIGURE 23

## PARTS LIST FIGURE 40 CONT

Item No.	Part No.	Description
1	189-573	Elbow
2	250-116	Punch Clamp
3	100-664	Hose 54"
4	301-514	Tube
5	141-008	Inlet Filter

# STRIPING ACCESSORIES

## STENCIL KIT

For use on any single gun striper for stencilling or spraying paint. Includes a 2nd gun, 50' of 1/4" airless hose, 18" extension pole & shut-off ball valve.

PART # 305-399



## 12GAL CONTAINER

High capacity plastic paint bucket

PART # 189-006



## POINTER

For easy line-up and striping of long lines.

PART # 136-069



## BEAD DISPENSERS

Gravity type glass bead dispenser kits.

- 1 GUN 4" PN 305-174
- 1 GUN 4-6" PN 305-186
- 2 GUN 4" PN 305-175
- 2 GUN 4-6" PN 305-178



## Quick Flush™

- The only clean water flushing system
- Cuts sprayer clean-up time in half!
- Connects to standard garden hose to backflush sprayer through gun
- Includes "F" and "G" adapters to work with all brands of gun

Part # **170-005**

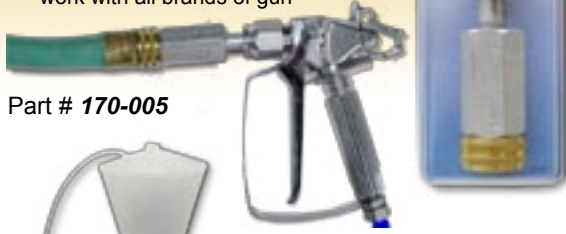

## PAINT HOPPER

For use on small jobs where paint is kept in smaller than 5 gallon containers. Threads onto pick-up tube of carry or LoBoy framed Airlessco sprayers.

**331-775** 6 Liter Paint Hopper

## PUMP CONDITIONER

Should be used on piston pumps between uses to prevent paint from drying on the piston & causing packing wear.

**010-001** Display of 48 - 1 oz. bottles  
**010-009** 1 quart bottle  
**010-019** 1 Gallon bottle

Case quantity: 12 on quarts, 4 on gallons



## PAINT STRAINERS

Pre-filter your paint using strainer bags. One dozen per pack.

**100-064** Used to cover suction filter  
**100-065** 5 Gallon strainer



## HOSE COVER

4 mil poly protects your airless hose from paint and abrasion damage. Comes in 1000' roll with perforations each 50'.

**100-219** Hose Cover Roll  
**100-426** Case of 6 Rolls

## HIGH PRESSURE AIRLESS HOSE

*Strong yet flexible, for airless sprayers up to 3300 PSI*

Part No:	Hose Description
<b>100-012</b>	3/16" Whip Hose, 4 Ft.
<b>100-040</b>	1/4" Whip Hose, 3 Ft.
<b>100-204</b>	1/4" Whip Hose, 5 Ft.
<b>100-199</b>	3/8" Whip Hose, 6 Ft.
<b>100-011</b>	1/4" Hose, 50 Ft.
<b>100-023</b>	3/8" Hose, 50 Ft.
<b>100-037</b>	1/2" Hose, 50 Ft.
<b>100-010</b>	1/4" Hose Connector
<b>100-009</b>	3/8" Hose Connector



## STAY CLEAN™

Spray protectant for machine to prevent paint from sticking to it. Keeps your sprayer looking new for years!

**114-030** 20 oz. can  
 Case quantity: 12 cans



## THROAT SEAL OIL

Used in the wet cup of a piston pump to prevent paint from drying on the piston & causing damage to the upper packing. Use with all piston pumps.

**188-187** 6 oz. Bottle  
**188-392** 1 qt. Bottle



## XTEND-A-POLE SYSTEM

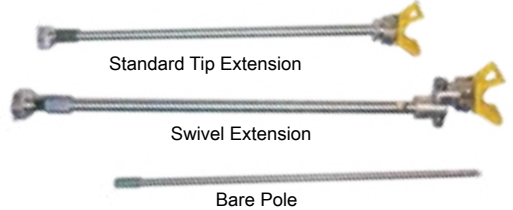

### STANDARD TIP EXTENSION, "G" Thread

**032-170** 6" Long  
**032-171** 12" Long  
**032-172** 18" Long  
**032-173** 24" Long

### SWIVEL EXTENSION, "G" Thread

**032-184** 36" Long

### BARE POLE

Add Tip Extension or Swivel Extension to create desired length

**032-053** 24" Long  
**032-054** 36" Long

### SWIVEL "G" THREAD

**032-035-55** 7/8" x 14 Swivel



## ADAPTERS



90° Pole to Gun Adapter  
**032-042**

Gun Nut "F" Thread 11/16-16  
**032-010**

Gun Nut "G" Thread 7/8-14  
**032-011**

"F to G" Gun adapter to attach Graco® tips to Airlessco guns.  
**032-012**