

# MVB Pump Packages



**MVB PUMP USED WITH “BLOCK” FEEDER SYSTEMS**

The MVB lubrication system is a single line, series progressive system which divides pump output into predetermined proportional amounts and distributes these amounts to points of lubrication. The MVB lubrication systems were developed to handle the higher operating pressures typically seen in the gas engine and compressor industry, and to offer the advantages of a series progressive system over a box lubrication system.

**These advantages are:**

- One main supply from single pump
- Central monitoring of normal operation
- Automatic proportioning of lubricant through positive displacement valves
- Quick indication of problem areas
- Usually, lower cost

This system consists of the MVB pump, MH divider valves and monitoring devices. The MVB pump provides lubricant to the MH divider valves. The MH divider valves proportion the pump flow based upon the relative size of the pistons within the valve assembly. This is then supplied to the lubrication point or into another divider valve assembly and then to a lube point.

Since the divider valve operates in a series progressive manner, each piston must successfully provide lube to its outlet before another can move. This allows for greater monitoring capabilities. By attaching a proximity switch to the MH divider valve, the valve assembly can be monitored for the required cycle rate. The signal generated by the proximity switch can be supplied to a Sentinel Monitor which senses any significant decrease in lube flow rate before the overall lubrication of the system is affected, at which time the Sentinel Monitor generates a signal for warning or shutdown. Figure 1 shows a typical MVB system

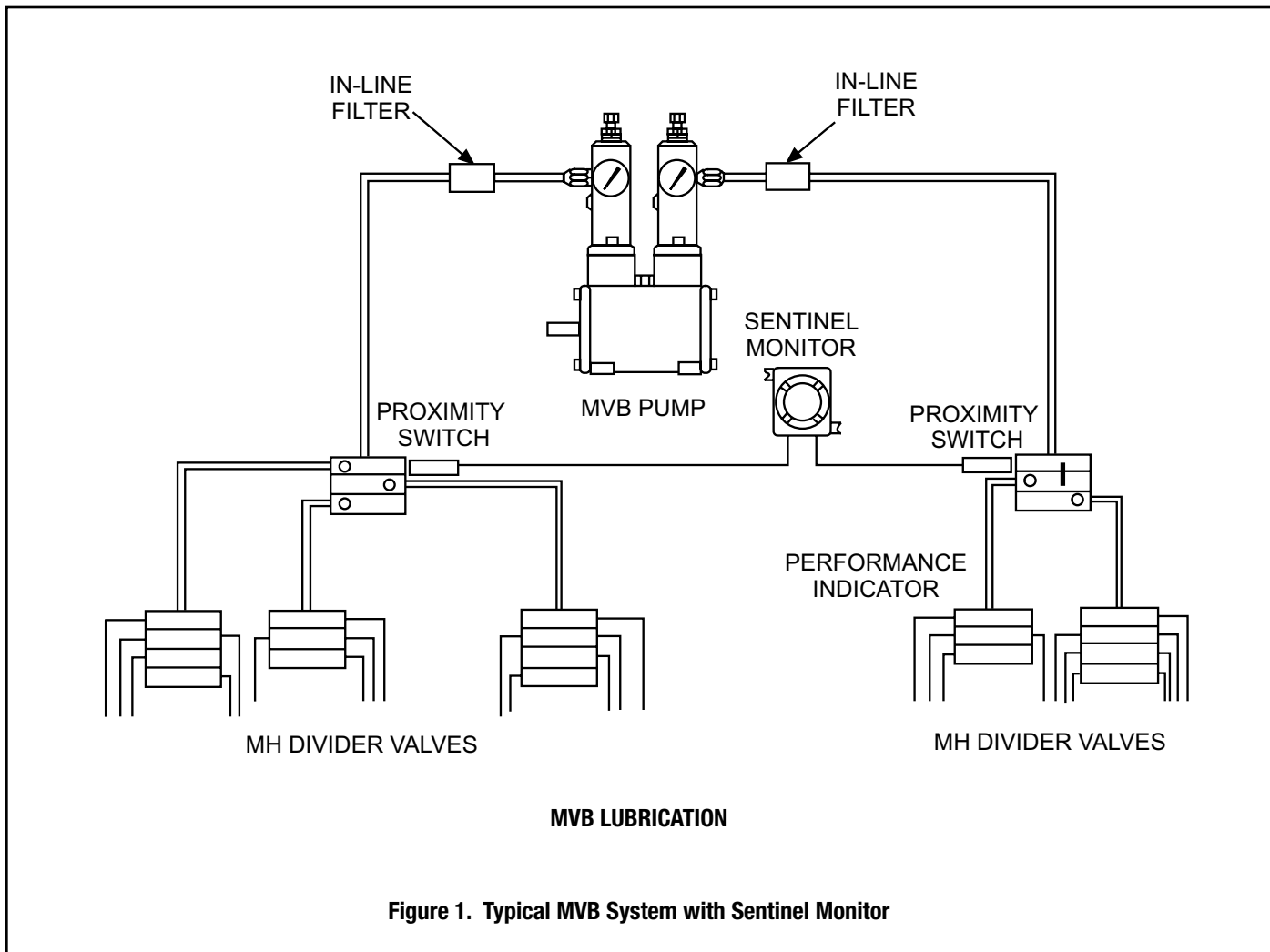

Other means of monitoring include the Lube Meter Panel which provides the operator, upon visual inspection, a quick and accurate observation of the inlet flow to the system in terms of flow rate and pressure. This is usually accompanied with a Lube Sentry, which is a no-flow device. When the flow of oil to the system stops, the Lube Sentry produces an electric or pneumatic signal which energizes a light, horn, siren, or shuts down the engine. Figure 2 illustrates an MVB system with the items installed.

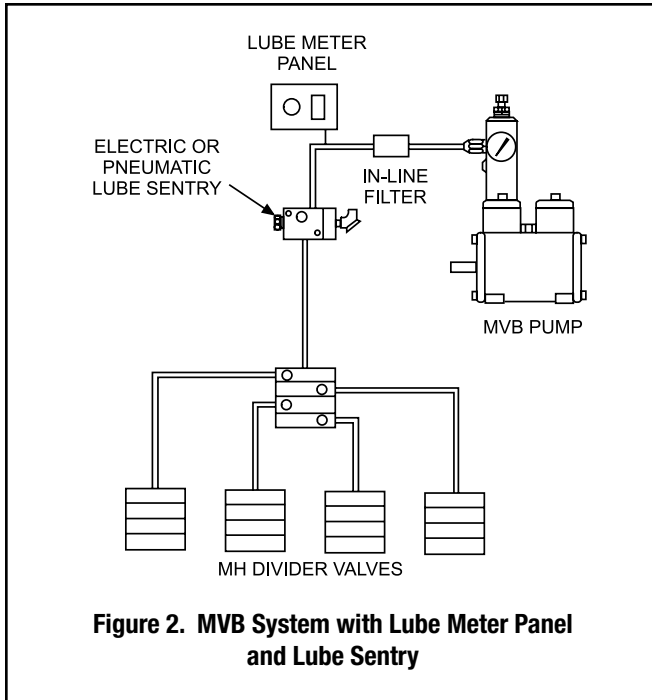

**Figure 2. MVB System with Lube Meter Panel and Lube Sentry**

For further information on these products and other accessories please consult the appropriate brochures listed in Table 1.

**DESCRIPTION**

A basic pump to multi-point system is shown in Figure 3 which depicts a single MVB pump with a standard drive gearbox. In this figure, the pump is located at Station 1; Station 2 is vacant. The single pump provides a continuous supply of oil to a divider valve which dispenses oil to multiple lubrication points. The MVB pump is driven by a cam located in the gearbox.

TABLE 1 ACCESSORIES	
Product	Literature No.
Lube Meter Panel Assembly	L14630
Electric & Pneumatic Lube Sentry	L15831
Check Valves	L15825
In-Line Filters	L15200
Reset & Pin Indicators	L15401
Series Progressive Divider Valves	L10103
Sentinel Monitors	L14701
Balancing Valves	L15812
Cycle Indicator Switches	L15600

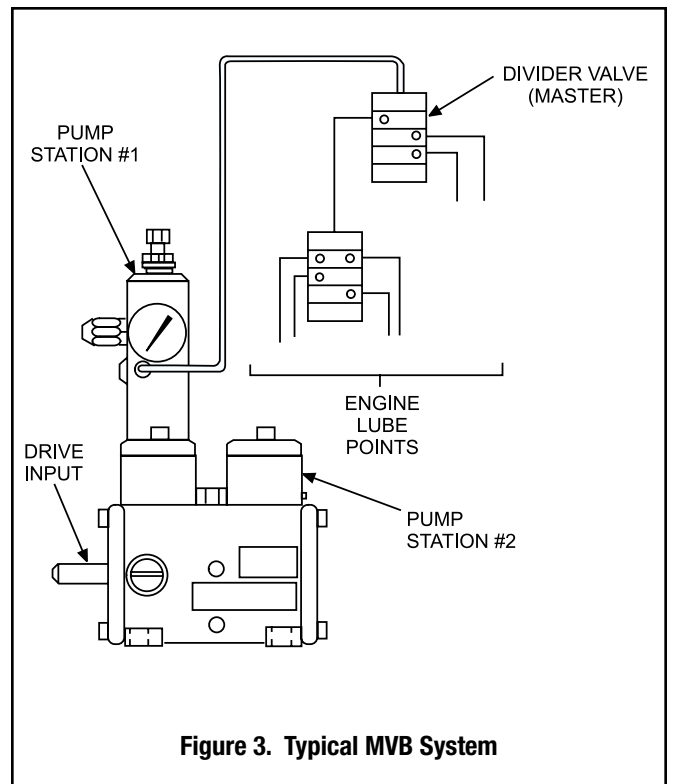

**Figure 3. Typical MVB System**

**MVB MODULARITY**

The MVB pump package provides a positive method of lubrication. A wide choice of standard modular components and off-the-shelf options allow you to custom design a system for your application. Figure 4 illustrates the major components of a MVB pump package.

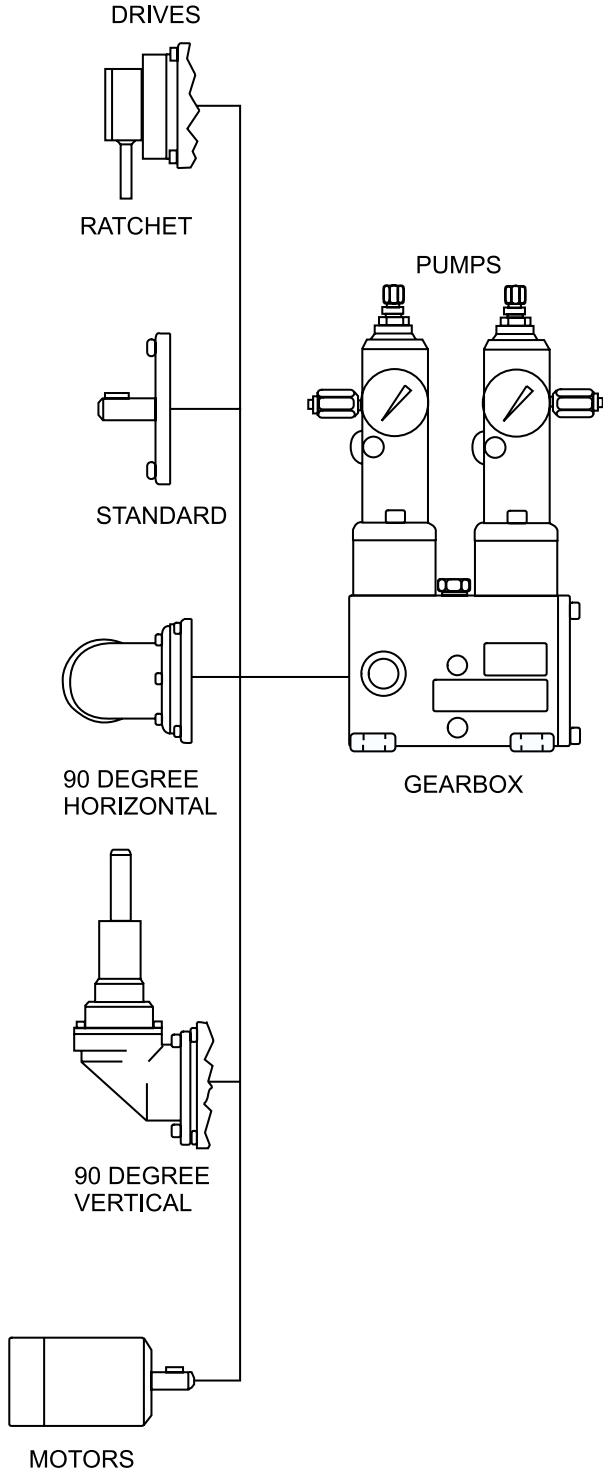

**PUMPS:**

Two piston sizes are available for the MVB pump. The pump is cam driven and provides lubricant at pressures up to 8000 PSI (552 bar) and flow rates up to 300 pints (142 liters) a day. For details see page 6.

**GEARBOXES:**

A range of 10 different final drive gear ratios to further increase or decrease input rpm and three types of drive cams are available for the gearbox. Each gearbox provides mounting for one or two MVB pumps. Pump mounting positions are identified as Station 1 or Station 2. For details see page 10.

**DRIVE OPTIONS:**

The gearbox drive is available in six different configurations including reverse, 90 degree, and vertical format. These drives allows the MVB package to be driven by the engine or compressor. If independent package control is desired, a motor option is available to provide the driving input. For details, see pages 11.

**Figure 4. MVB Components**

**MVB PUMP PACKAGES FEATURES/BENEFITS**

- MVB pump packages provide a proven, cost-effective way to assemble customized lubrication systems to meet specific volume and pressure requirements by using standard modular components.
- 8000 PSI (552 bar) pressure capability rates among the highest in the industry.
- By selecting from two different pump sizes, ten available gear ratios and three operating cams, an MVB system can deliver 2 to 300 pints (0.95 to 142 liters) per day. This allows for flexibility in design to handle a wide variety of applications.
- Single pump can supply all lube points on the equipment, making output adjustment a simple operation.
- Available pre-lube package provides for quick lubricant flow during start-up after extended downtime.

**APPLICATIONS AND INDUSTRIES**

All working parts of the MVB pump package are totally enclosed away from dirt, water and impurities. Each moving part is lubricated internally at all times. This and the wide range of options, high discharge pressure and rugged construction plus the many other features and benefits make MVB pump packages ideally suited for the applications and industries shown in Table 2.

**Table 2. MVB Applications**

APPLICATION	INDUSTRY	USE
Compressors and Reciprocating Engines	Petrochemical Refineries	Lubricate cylinder walls and piston shaft packings.
	Gas Transmission, Injection and Storage	
	Cold Storage	
	General Manufacturing Air Systems	
Banbury Mixers	Rubber	Lubricate Dust Seals

**PUMPS**

**DESCRIPTION**

MVB pumps (Figure 5) are heavy-duty precision, full-stroke pumps capable of pumping oil efficiently at a wide range of pump cycle rates and pressures. Designed to lubricate reciprocating engines and compressors, this single piston pump is mechanically driven by a camshaft in the gearbox. The pump output is easily adjustable from 0.0025 to 0.03 inch<sup>3</sup> (0.041 to 0.49 cm<sup>3</sup>) per stroke. The pump is rated for pressures up to 8000 PSI (552 bar) depending on piston size. Pistons are available in 0.250 inch (6.35 mm) or 0.375 inch (9.53 mm) diameters to fit the output requirements. All working parts are enclosed for protection against dirt, water and impurities and are self-lubricated at all times by the lubricant being pumped.

The MVB pumps are rugged, heavy-duty units. The pump cylinder housing is a precision machined casting fitted with an alloy steel piston.

Ordering codes for pumps are AOA through AOD and BOA through BOD depending on pump placement, piston diameter and options ordered.



**Figure 5. MVB Pump**

**FEATURES/BENEFITS**

- Rugged construction for high performance and durability.
- Easy serviceability—pumps can be removed, repaired, or replaced very quickly.
- Pump piston stroke has sufficient volume to handle “aerated oil” without risk of air-lock.
- Pump output is easily adjustable.

**OPERATION**

Figure 6 provides a cutaway view of a typical MVB pump. Lubricating oil is either gravity fed or pressure fed from the crankcase of the engine or compressor being lubricated to the inlet port of the pump. Rotation of the gearbox cam actuates the pump piston. The piston moves up in the power stroke, closing off the inlet port. The piston continues on the power stroke forcing lubricant past the internal check valves through the outlet port and into the system. The piston travels the same distance on every stroke. This full-stroke action provides a smooth flow of lubricant.

The output of the pump is adjustable by means of the 1-1/2 inch (28.58 mm) hexnut on the pump top. Adjusting this hexnut changes the inlet port position in relation to the piston top, regulating the discharge volume.

**ADJUSTMENT**

Pump output is easily adjusted within the minimum and maximum ranges as shown in Figure 7. To adjust the output proceed as follows:

1. Reduce outlet pressure below 1000 psi by loosening outlet fitting, or alternate outlet plug.
2. Loosen setscrew.
3. Turn hexnut clockwise to increase the output and counterclockwise to decrease the output. (Do Not exceed the 0.484 (12.24) min. output adjustment).
4. When the desired output volume is attained, retighten the setscrew.
5. Retighten outlet fitting, or alternate outlet plug.

Table 3 provides output changes in relation to number of turns the hexnut is adjusted. Note that full stroke is when hexnut is flush with body.

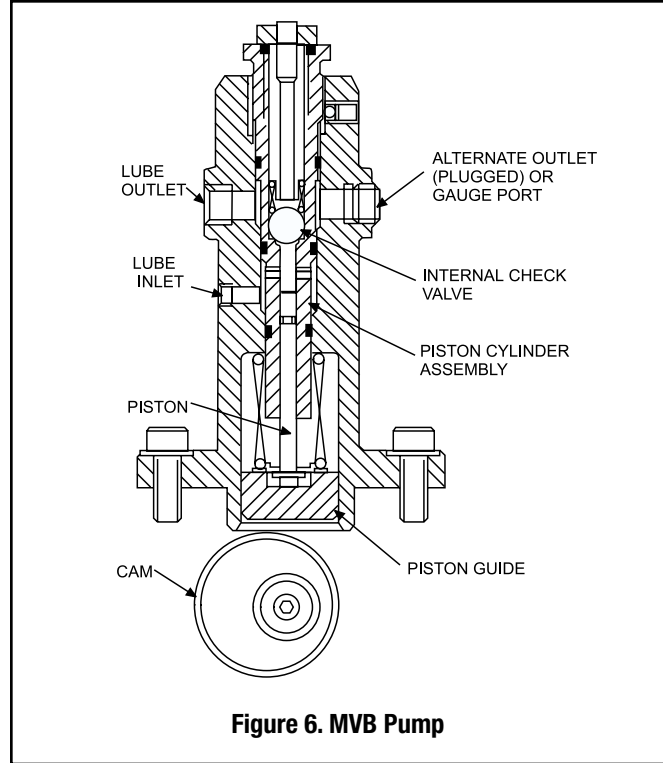

**Figure 6. MVB Pump**

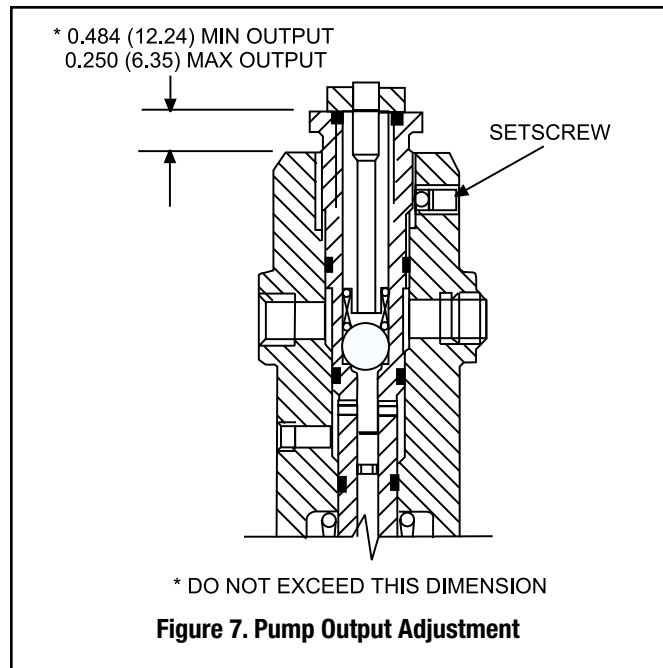

**Figure 7. Pump Output Adjustment**

**Table 3. Output Adjustments**

		0.250 (6.35) Dia Piston		0.375 (9.53) Dia Piston	
		Inch <sup>3</sup>	(cm <sup>3</sup> )	Inch <sup>3</sup>	(cm <sup>3</sup> )
Hexnut turns, counterclockwise from full stroke	Full Stroke	0.012	(0.197)	0.030	(0.492)
	1/4	0.011	(0.187)	0.028	(0.466)
	1/2	0.011	(0.175)	0.027	(0.439)
	3/4	0.010	(0.164)	0.025	(0.413)
	1	0.010	(0.156)	0.024	(0.387)
	1-1/4	0.009	(0.146)	0.022	(0.361)
	1-1/2	0.008	(0.134)	0.020	(0.334)
	1-3/4	0.008	(0.124)	0.019	(0.308)
	2	0.007	(0.115)	0.017	(0.282)
	2-1/4	0.006	(0.103)	0.016	(0.256)
	2-1/2	0.006	(0.093)	0.014	(0.230)
	2-3/4	0.005	(0.084)	0.012	(0.203)
	3	0.004	(0.072)	0.011	(0.177)
	3-1/4	0.004	(0.062)	0.009	(0.151)
3-1/2	0.003	(0.051)	0.008	(0.125)	
3-3/4	0.003	(0.041)	0.006	(0.098)	

**PUMP OPTIONS**

Options which may be ordered with any pump are listed below.

**Pressure Indicator.** The pressure indicator option mounts on top of the pump and provides a visual indication of an overpressure condition. A pressure disc inside the indicator ruptures when its rated pressure is reached, allowing the excessive pressure to be relieved. The standard pressure indicator uses a disc rated at 2350 PSI (162 bar).

Ordering codes for pressure indicators are POA for a pump at Station 1 and HOA for a pump at Station 2.

**System Fill.** This option consists of a tee fitting and a check valve mounted on the second lube outlet on the pump body. This option provides an easy means of filling lube delivery lines downstream of the pump before system start-up. When started, since the lube lines are full, the lube pump begins pumping lubricant directly to the lube points. This option also facilitates system bleeding and troubleshooting.

The system fill option is included with the pump when options AOC or AOD (for a Station 1 pump) or options BOC or BOD (for a Station 2 pump) are ordered.

**Pressure Gauges.** A pressure gauge option is available to display pump output pressure. This gauge mounts directly to the alternate lube outlet on the pump body. Gauges are available in two ranges, 0 to 3,000 PSI and 0 to 10,000 PSI, and in either a dry or liquid-filled style.

Ordering codes for gauges are GOA through GOD, for a Station 1 pump, and JOA through JOD for a Station 2 pump. Codes will vary depending on style and pressure selected.

**Filter/Primer Unit.** A filter/primer unit is available with either a 10 or 25 micron filter element that prevents any contaminants or particles from reaching the pump or the lubrication points. It has

a unique self-scrubbing feature that lowers the frequency of filter changes. The filter/primer maintains 0.33 pint (0.16 liter) of oil, for pump priming, when the engine or compressor shuts down, and prevents any air trapped in the oil from entering the pump. The filter/primer assembly features a plastic housing except where noted in table 4.

The filter/primer unit is not ordered with a code from the ordering menu. For ordering information refer to Table 4.

**Table 4. Filter/Primer Unit Ordering Information  
40 PSI Rating (Type.)**

COMPONENT ORDERING		
Description	Part No.	Old Part No.
Filter/Primer for Single Pump Head, 10 micron	563563	542-767-051
Filter/Primer for Single Pump Head, 25 micron	563564	542-767-251
Filter/Primer for Dual Pump Head, 10 micron	—	542-640-053
Filter/Primer for Dual Pump Head, 25 micron	564418	542-640-253
Remote Filter, 10 micron, Metal Housing	563560	542-562-551
Remote Filter, 25 micron, Metal Housing	563561	542-562-751
Replacement 10 micron Element	557827	542-045-000
Replacement 25 micron Element	557824	541-168-000

SPECIFICATIONS	
<b>0.250 in (6.35 mm) Piston</b>	
Part Number	563565 (542-999-050)
Max Output per Stroke	0.012 in <sup>3</sup> (0.917 cm <sup>3</sup> )
Min Output per Stroke	0.0025 in <sup>3</sup> (0.041 cm <sup>3</sup> )
Pressure Rating	
w/single-lobe cam	8000 psi (552 bar)
w/ double-lobe cam	5000 psi (345 bar)
w/triple-lobe cam	4000 psi (276 bar)
<b>0.375 in (9.53 mm) Piston</b>	
Part Number	563566 (542-999-060)
Max Output per Stroke	0.030 in <sup>3</sup> (0.492 cm <sup>3</sup> )
Min Output per Stroke	0.006 in <sup>3</sup> (0.098 cm <sup>3</sup> )
Pressure Rating	
w/single-lobe cam	3000 psi (207 bar)
w/double-lobe cam	2000 psi (138 bar)
w/triple-lobe cam	1500 psi (103 bar)
Outlet Ports	1/4-18 NPSF
Inlet Port	3/8-18 NPSF
Min Strokes per Min	5
Max Strokes per Min	250

Minimum pump strokes per minute is 5. Maximum pump per minute is 250. Make sure with the in pump rpm, selection of gear ratio and choice of cam, the actual number of pump strokes is between 5 and 250.

**DIMENSIONS**

Figure 8 provides dimensions for the MVB pumps and related options.

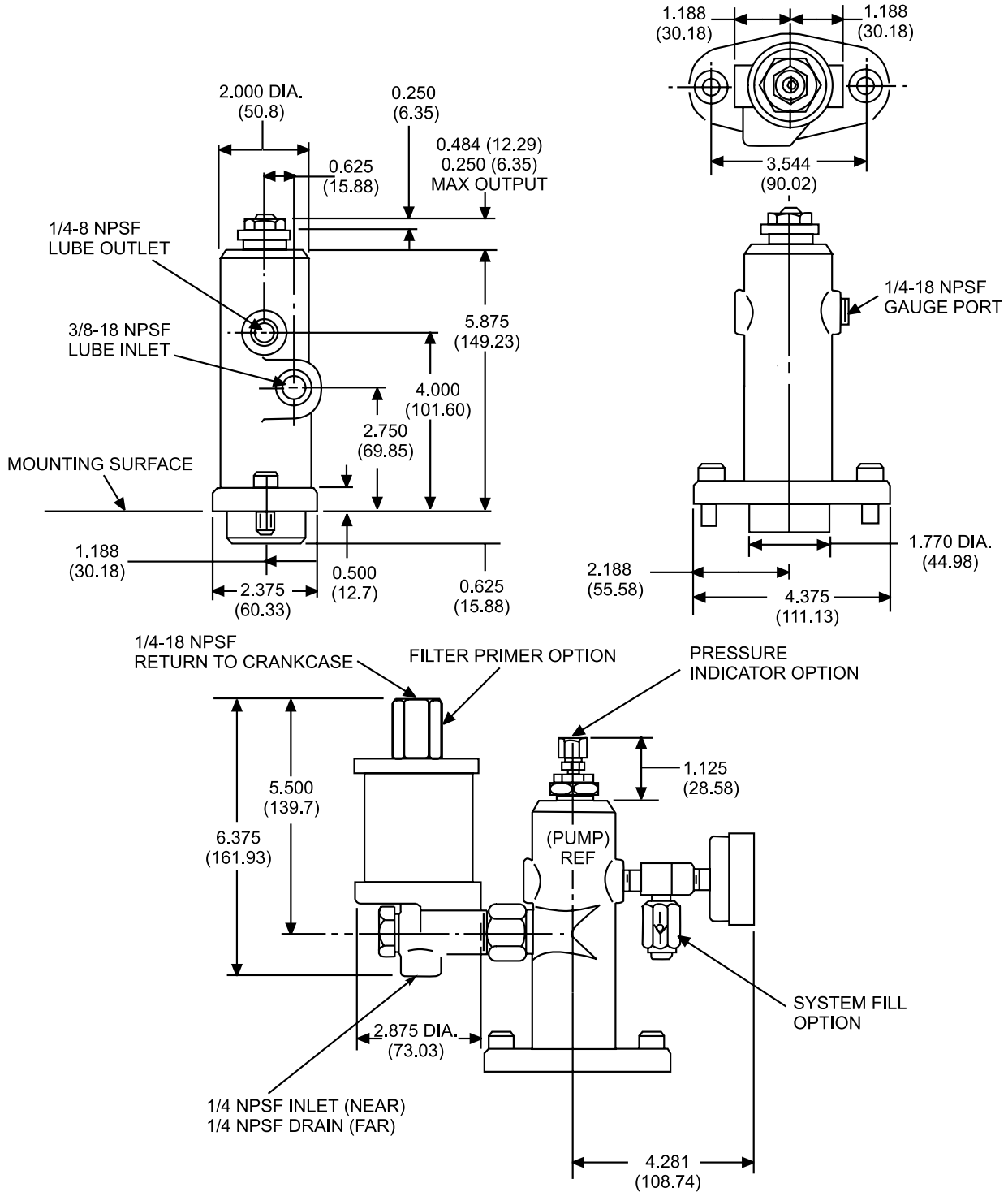

**Figure 8. Pump Dimensions**



## GEARBOXES

### DESCRIPTION

Gearboxes consist of a machined, cast aluminum main housing within which are the drive-shaft and camshaft. This compact, easily mounted unit has positions for mounting one or two MVB pumps. A wide selection of gear ratios and cam configurations actuates the pumps to provide the desired lube output.

Roller bearings on the drive-shaft and camshaft provide smooth operation as well as ease of maintenance. The gearbox is designed to hold its own lubricant supply of **SAE 90 oil**, completely independent of the oil lubricating the engine or compressor. A sight glass allows quick determination of gearbox oil level, while a breather vent prevents internal pressure buildup due to a rise in operating temperatures.

A variety of drives are available allowing the gearbox to be connected to the engine or compressor. Or, if desired, a separate motor may be used to allow independent operation.

### FEATURES/BENEFITS

- Totally enclosed gears and bearings provide long life and reduce downtime and maintenance costs.
- Wide variety of drive options to connect to various configurations.
- Mounting positions for one or two pumps allows easy expansion or reduction of system.
- Wide drive ratios and cam options provide excellent means of sizing lube output to the requirements.

### OPERATION

Gearboxes are available in ten ratios to suit your application. As shown in Figure 9, the drive shaft rotates at the input rpm, rotating the drive-shaft gear. Gear clusters, which rotate freely about their respective shaft, provide the necessary reduction or step-up rpm to the camshaft gear. As the camshaft rotates, the lobes of cams at pump Stations 1 and 2 actuate the MVB pumps. Cams are available in single, double or triple lobe configurations. With the cam options and wide variety of gear ratios, gearbox output is easily designed to fit any application.

### ORDERING CODES

When ordering a gearbox, several different codes are used as follows:

- DAA through DAF for the selected drive
- RAA through RAK for ratios
- CAA, CAB or CAC for cam style at Station 1
- FAA, FAB or FAC for cam style at Station 2

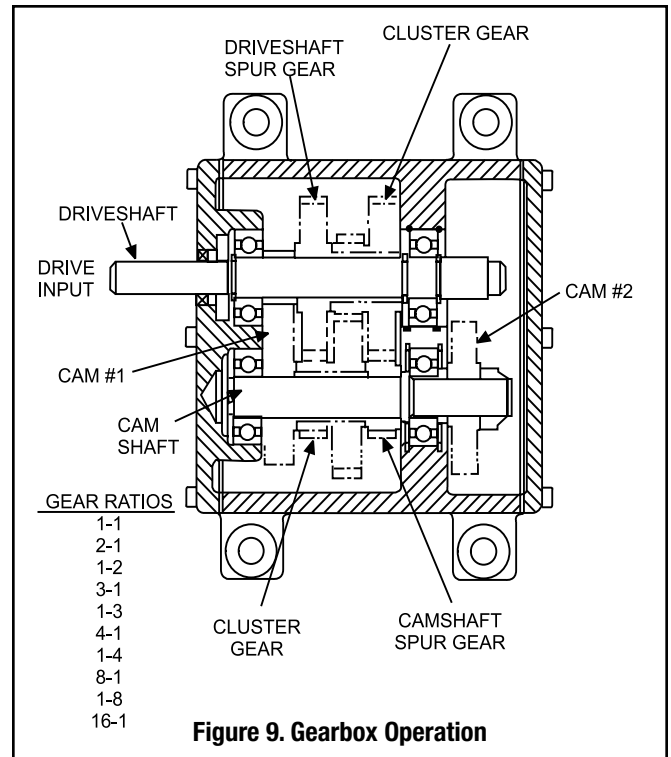

Figure 9. Gearbox Operation

### DRIVE OPTIONS

The input drive for the gearbox is available in six different configurations. By using one of the drive options the gearbox is adaptable to virtually any drive orientation you may have. The various types of drive options are listed below.

**Ratchet Drive.** This option allows the drive-shaft to be driven by reciprocating motion of your equipment. Two mounting holes allow connection to reciprocating rods with 1-1/4 or 1-3/4 inch (31.75 or 44.45 mm) stroke. Figure 10 illustrates the ratchet drive, option DAA.

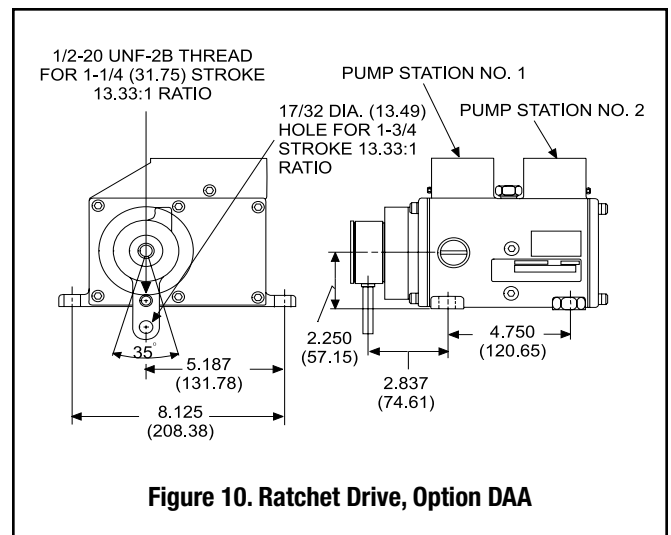

Figure 10. Ratchet Drive, Option DAA

**Standard Drives.** Two styles of standard drives are available. Both have a 0.825 inch (15.88 mm) diameter drive-shaft for attachment to the appropriate driving source. One of the standard styles has a slightly longer drive-shaft and is specifically designed for use in the package using the Graco supplied motor and coupler. Figure 11 shows a typical standard drive.

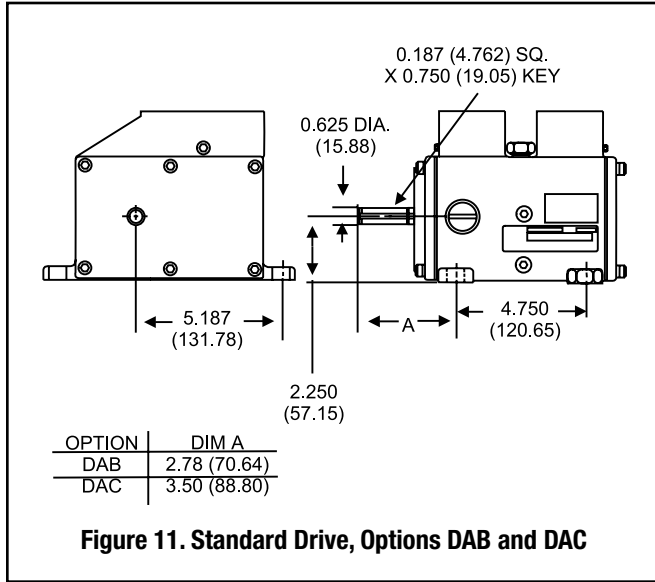

Figure 11. Standard Drive, Options DAB and DAC

**90 Degree Drive.** A bevel gear arrangement allows the drive-shaft to extend from the rear of this unit. Figure 13 illustrates the 90 degree drive, option DAE.

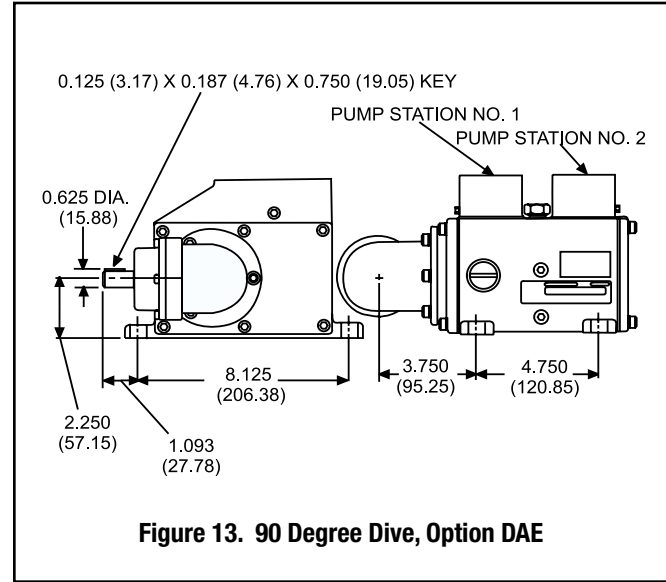

Figure 13. 90 Degree Drive, Option DAE

**Reverse Drive.** This drive is the same as the standard drive except the shaft extends from the right-hand side of the gearbox. Figure 12 illustrates the reverse drive, option DAD.

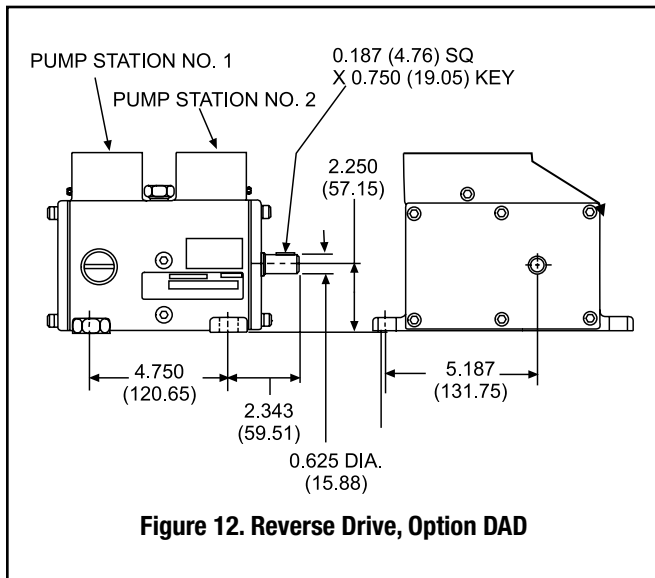

Figure 12. Reverse Drive, Option DAD

**Vertical Drive.** A bevel gear arrangement allows the drive-shaft to extend in the vertical direction. The shaft is long enough to allow clearance for connections to the pump. Figure 14 illustrates the vertical drive, option DAF.

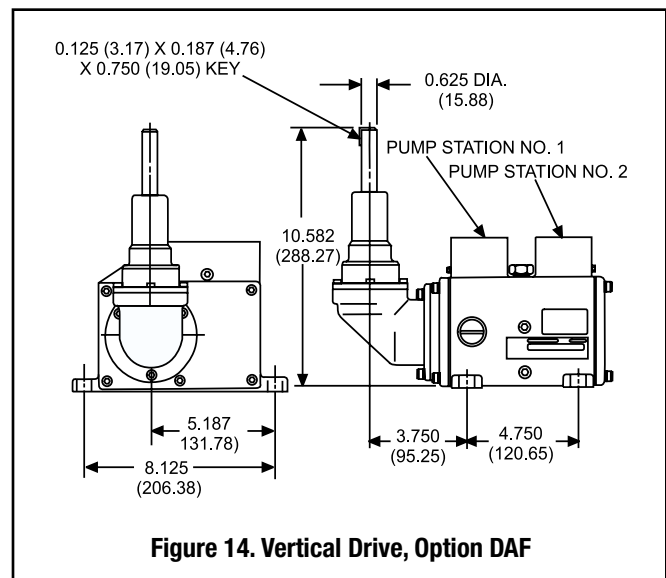

Figure 14. Vertical Drive, Option DAF

**NOTE:** Gearbox cover is drilled and tapped with multiple mounting holes that allow right angle drives to face rear, front, up, or down.

**Motor Drive.** A 1/4 Hp motor-driven gearbox is available directly from Graco for remote location applications and pre lubrication capability. The motor is available in 115/230 VAC single-phase (option MOA) or 230/460 three-phase (option MOB) ratings. A base (option KOA) is available to provide secure mounting for the motor and gearbox. Figure 15 shows a typical arrangement of motor and gearbox mounted on the base.

**SPECIFICATIONS**

The expected oil output per pump from any gearbox depends on drive ratio chosen, camshaft rpm, and pump size. Table 5 provides output of a single pump operated by a single-lobe cam at various camshaft rpm. Other outputs at different camshaft rpm can be determined by multiplying the camshaft rpm by the constant. For double- or triple-lobe cams multiply the output by 2 or 3 respectively to arrive at the total pump output.

**NOTE:** Minimum pump strokes per minute is 5. Maximum pump strokes per minute is 250. Make sure that with the input rpm, selection of gear ratio and choice of cam, the actual number of pump strokes is between 5 and 250 per minute.

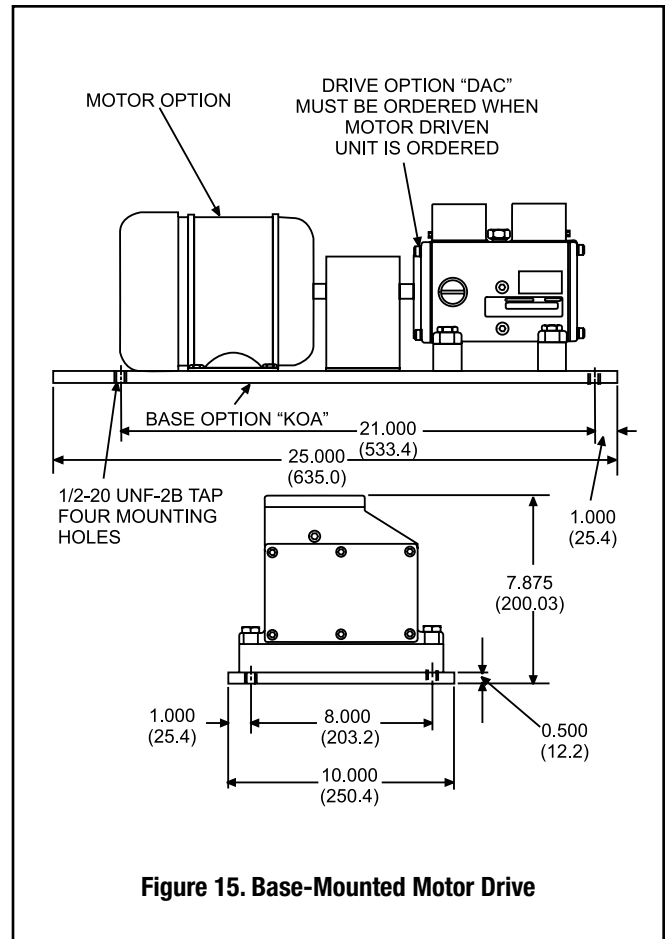

Figure 15. Base-Mounted Motor Drive

Table 5. Output per Pump in Pints (Liters) per Day

Single Camshaft rpm (Pump Strokes Per Min.)	1/4 Piston		3/8 Piston	
	Min. Output Adj.	Max. Output Adj.	Min. Output Adj.	Max. Output Adj.
	0.12456	* (Constant) 0.59832	0.29909	* (Constant) 1.4902
20	2.49 (1.18)	11.97 (5.66)	5.98 (2.83)	29.92 (14.15)
30	3.74 (1.77)	17.95 (8.49)	8.97 (4.24)	44.88 (21.23)
40	4.98 (2.36)	23.93 (11.32)	11.96 (5.66)	59.84 (28.30)
50	6.23 (2.95)	29.92 (14.15)	14.95 (7.07)	74.80 (35.38)
60	7.47 (3.53)	35.90 (16.98)	17.95 (8.49)	89.76 (42.46)
70	8.72 (4.12)	41.88 (19.81)	20.94 (9.90)	104.72 (49.53)

\* Constant X strokes per minute = Output in pints per day. For 2 and 3 lobe cams, multiply camshaft RPM X 2 or 3.

# PACKAGE ORDERING INFORMATION (MENU)

MVB - XXX - XXX - XXX - XXX - XXX - XXX - XXX - XXX - XXX - XXX - XXX - XXX - XXX

## DRIVE OPTION

DAA - RATCHET DRIVE, 102-2  
DAB - STANDARD DRIVE, 203-2  
DAC - STANDARD DRIVE, 207-2  
DAD - REVERSE DRIVE, 303-2  
DAE - 90° DRIVE, 401-2  
DAF - VERTICAL DRIVE, 501-2  
D99 - SPECIAL SPECIFY PART NUMBER

## RATIO OPTION

RAA - 1:1    RAD - 1:3    RAG - 4:1    RAK - 16:1  
RAB - 1:2    RAE - 3:1    RAH - 1:8  
RAC - 2:1    RAF - 1:4    RAJ - 8:1

## CAM OPTION STATION 1

CAA - SINGLE-LOBE  
CAB - DOUBLE-LOBE  
CAC - TRIPLE-LOBE

## CAM OPTION STATION 2

FAA - SINGLE-LOBE  
FAB - DOUBLE-LOBE  
FAC - TRIPLE-LOBE

## PUMP OPTION STATION 1

A00 - NONE  
AOA - 1/4 DIA PUMP ONLY, (542-999-050)  
AOB - 3/8 DIA PUMP ONLY, (542-999-060)  
AOC - 1/4 DIA PUMP W/SYSTEM FILL, (542-999-070)  
AOD - 3/8 DIA PUMP W/SYSTEM FILL, (542-999-080)

## PUMP OPTION STATION 2

B00 - NONE                            BOC - 1/4 DIA PUMP W/SYSTEM FILL, (542-999-070)  
BOA - 1/4 DIA PUMP ONLY, (542-999-050)    BOD - 3/8 DIA PUMP W/SYSTEM FILL, (542-999-080)  
BOB - 3/8 DIA PUMP ONLY, (542-999-060)

## \*PRESSURE INDICATOR OPTION STATION 1

POA - STANDARD BLOWOUT, 2350 PSI, (509-230-160)  
P99 - SPECIAL SPECIFY PART NUMBER

## \*PRESSURE INDICATOR OPTION STATION 2

HOA - STANDARD BLOWOUT, 2350 PSI, (509-230-160)  
H99 - SPECIAL SPECIFY PART NUMBER

## \*GAUGE OPTION STATION 1

GOA - GAUGE 0-3000 PSI, DRY, (543-362-000)                    GOD - GAUGE 0-10000 PSI, LIQUID FILLED, (493-020-207)  
GOB - GAUGE 0-3000 PSI, LIQUID FILLED, (510-770-240)    G99 - SPECIAL SPECIFY PART NUMBER  
GOC - GAUGE 0-10000 PSI, DRY, (493-020-206)

## \*GAUGE OPTION STATION 2

JOA - GAUGE 0-3000 PSI, DRY, (543-362-000)                    JOD - GAUGE 0-10000 PSI, LIQUID FILLED, (493-020-207)  
JOB - GAUGE 0-3000 PSI, LIQUID FILLED, (510-770-240)    J99 - SPECIAL SPECIFY PART NUMBER  
JOC - GAUGE 0-10000 PSI, DRY, (493-020-206)

## \*BASE OPTION

KOA - STANDARD, SEE NOTE 1

## \*MOTOR OPTION

MOA - 1/4 HP, 115/230 VAC, 60 HZ, SINGLE-PHASE, 1725 RPM, TENV, 56 FRAME  
MOB - 1/4 HP, 230/460 VAC, 60 HZ, THREE-PHASE, 1725 RPM, TENV, 56 FRAME  
M99 - SPECIAL SPECIFY PART NUMBER

\*OMIT IF NOT REQUIRED

### NOTE:

(1) Base option KOA allow for mounting of a 56 frame motor to MVB package and include coupling and coupling guard. When base option KOA is ordered drive option DAC is to be ordered, along with either gear ratio RAJ (8:1) or RAK (16:1). This is to ensure that motor is properly mounted and maximum input rpm is not exceeded.

## Contact us today!

To receive product information or talk with a Graco representative,  
call 800-533-9655 or visit us online at [www.graco.com](http://www.graco.com).

