

MSA-10 Air Operated Pump

DESCRIPTION

The MSA-10 is an air-operated pump with an adjustable volume output. It is designed to be used in series progressive oil or grease lubrication systems. Lubricant can be supplied to the MSA-10 pump by either a gravity feed reservoir or a pressurized source such as a bulk header that exerts up to 500 psi at the pump inlet. This pressure handling capability is a result of the pump pistons valving action which prevents lubricant from flowing into the lube system when the piston is in the priming position. The MSA-10 is supplied as a single-acting pump. However, it can easily be field-converted to double-acting by removing the plastic vent plug from the double-acting port and installing an air line.

FEATURES

- Adjustable lube output, from .040 to .120 cubic inches per stroke, permits a broad range of applications.
- The MSA-10 is ideal for bulk header lube systems because it can handle up to 500 psi inlet pressure.
- Single-or double-acting air cylinder provides wide choice of controls.
- Ability to pump either oil or grease expands the opportunity to standardize on the MSA-10 throughout the plant or shop.
- High pressure relief protection reduces chance of damage to the lube system in case of blockage.
- Can be piped to standard Trabon reservoirs. (Refer to bulletin L12000 for reservoirs.)

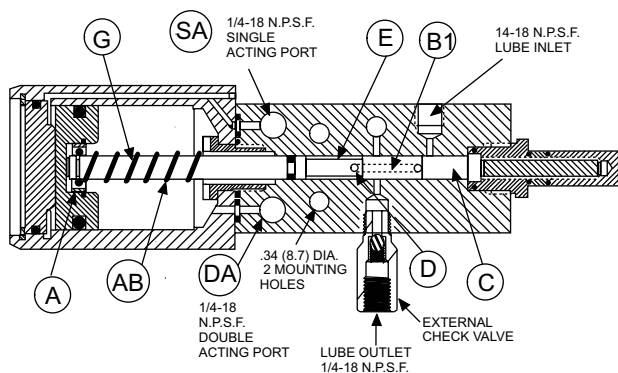

OPERATION

When air is supplied in the single-acting port (SA), the pump piston (A) is moved forward. The lube inlet is closed by the piston (A/B). The lubricant in the chamber (C) is forced into a channel in the middle of the piston (B1). An outlet hole (D) from that channel opens into an undercut (E) on the piston. When the undercut (E) opens to the lube outlet, the lubricant from the chamber (C) flows, under pressure, to the lube system. If a blockage occurs in the lube system, the rupture indicator (not shown) opens and the pressure is vented. When the air has been vented from the single-acting inlet, the piston return spring (G) returns the piston to its original position. If the pump is double-acting, air will be supplied in the double-acting inlet (DA) as air is vented from the single-acting port.

SPECIFICATIONS

Material	Steel
Output per Stroke	0.040-0.120 cu.in. (0.66-1.97 cm ³)
Max Pump Stroke per Min	
Single-Acting	15
Double-Acting	60
Operating Pressure	
Air Inlet	40-150 psi (275.8-1034.2 kPa)
Max Lube Inlet	500 psi (3447.5 kPa)
Max Lube Outlet	1450 psi (9997.7 kPa), w/Standard 1450 psi Rupture-To-Atmosphere Indicator
Lubricant	Oil or Grease
Air to Lube	25:1

DIMENSIONS Inches (mm)

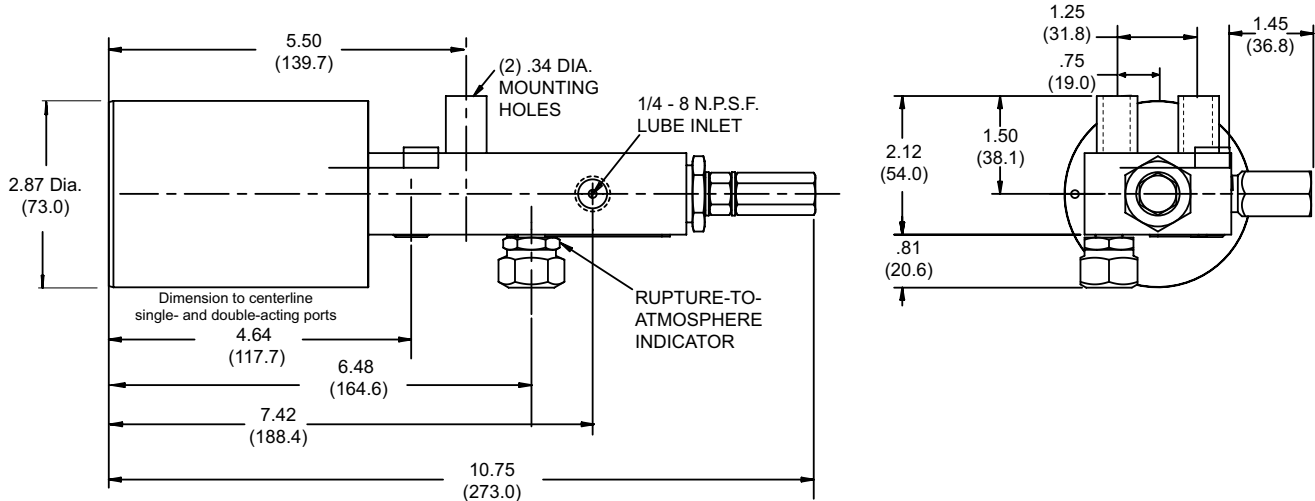

INSTALLATION INSTRUCTIONS

1. Mount pump using both mounting holes.
2. Seal all pipe connections. **DO NOT USE PTFE TYPE TAPE.**
3. Cycle the pump until all air is removed and lubricant runs clear at the outlet.
4. If you intend the MSA-10 to operate as a double-acting pump, remove the plastic vent orifice plug from the double-acting inlet port and install the air line to that inlet.
5. To adjust pump output, remove adjustment screw cap and turn the screw clockwise to reduce output, or counterclockwise to increase output.

ORDERING INFORMATION

Description	Part No.	Old Part No.
MSA-10 Air Operated Pump	562854	140-000-111
1450 psi Rupture-To-Atmosphere Indicator	—	511-839-100
Spare Parts Kit	563912	560-001-550
Air Inlet Restrictor Valve	563072	463-410-080

For MAS-10 pumps with higher max psi, refer to Bulletin L15401 or consult your Trabon distributor or the factory.

SPARE PARTS KIT

A handy spare parts kit is available and includes:

Appropriate O-rings (1, 2, 3, 4, 5, and 6); two gaskets (7): external check valve (for replacement of both external and internal types) (8); piston return spring (9); and complete instructions for installations.

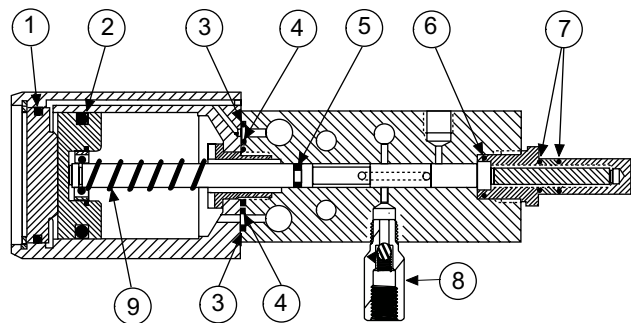

All written and visual data contained in this document are based on the latest product information available at the time of publication. Graco reserves the right to make changes at any time without notice.

Contact us today!

To receive product information or talk with a Graco representative, call 800-533-9655 or visit us online at www.graco.com.

