

INSTRUCTIONS-PARTS LIST



307-758

This manual contains **IMPORTANT INSTRUCTIONS and WARNINGS.**
READ AND RETAIN FOR REFERENCE.

Rev. R
Supersedes Rev. P

ELECTRIC, 120 VAC

ULTRA[®] 500 AIRLESS PAINT SPRAYER

2750 psi (195 bar) MAXIMUM WORKING PRESSURE

Model 231-032, Series C

Basic sprayer on Upright cart

Model 231-041, Series B

Complete sprayer on Upright cart, hoses, gun, RAC IV[®] DripLess[™] Tip Guard and SwitchTip[™]

Model 231-054, Series D

Basic sprayer on Lo-Boy cart without hose or gun

Model 231-055, Series B

Complete sprayer on Lo-Boy cart, hoses, gun, RAC IV[®] DripLess[™] Tip Guard and SwitchTip[™]

U.S. PATENT NO. 4,323,741, 4,397,610
PATENTED 1983, CANADA
AND OTHER PATENTS PENDING

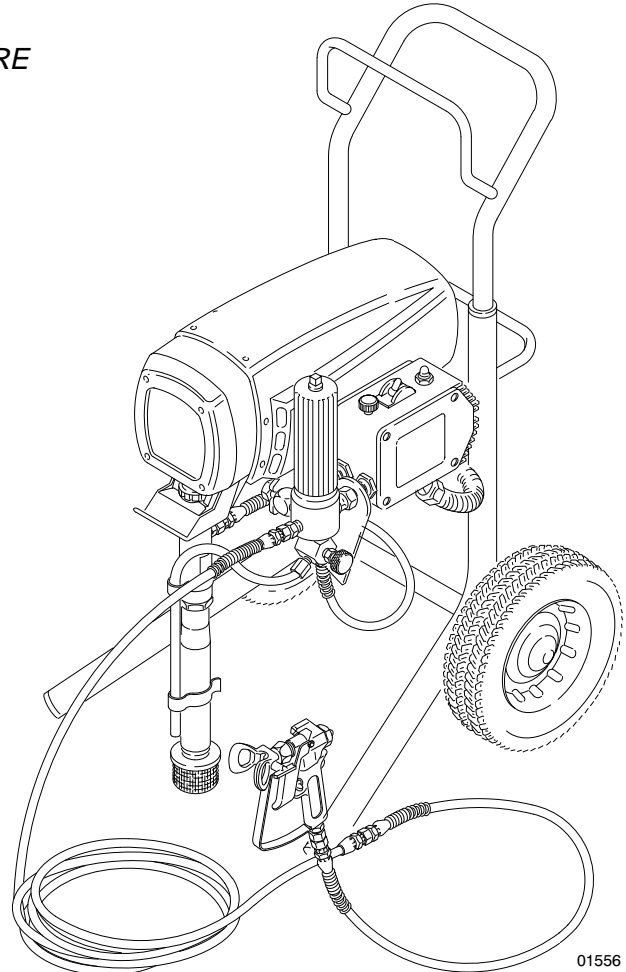

01556

NOTE: This is an example of the DANGER label on your sprayer.
This label is available in other languages, free of charge.
See page 46 to order.

! DANGER !			
	FIRE AND EXPLOSION HAZARD		SKIN INJECTION HAZARD
<p>Spray painting, flushing or cleaning equipment with flammable liquids in confined areas can result in fire or explosion.</p> <p>Use outdoors or in extremely well ventilated areas. Ground equipment, hoses, containers and objects being sprayed.</p> <p>Avoid all ignition sources such as static electricity from plastic drop cloths, open flames such as pilot lights, hot objects such as cigarettes, arcs from connecting or disconnecting power cords or turning light switches on and off.</p> <p>Failure to follow this warning can result in death or serious injury.</p>		<p>Liquids can be injected into the body by high pressure airless spray or leaks – especially hose leaks.</p> <p>Keep body clear of the nozzle. Never stop leaks with any part of the body. Drain all pressure before removing parts. Avoid accidental triggering of gun by always setting safety latch when not spraying.</p> <p>Never spray without a tip guard.</p> <p>In case of accidental skin injection, seek immediate "Surgical Treatment".</p> <p>Failure to follow this warning can result in amputation or serious injury.</p>	
READ AND UNDERSTAND ALL LABELS AND INSTRUCTION MANUALS BEFORE USE			

GRACO INC. P.O. BOX 1441 MINNEAPOLIS, MN 55440-1441

©COPYRIGHT 1986, GRACO INC.

TABLE OF CONTENTS

INTRODUCTION	2	REPAIR	
WARNINGS		General Repair Information	24
English	4	Motor Brush	25
French	6	Power Supply Cord	26
Spanish	8	On/Off Switch	26
SETUP	10	Bridge Rectifier	27
OPERATION	12	Circuit Breaker	27
Startup	12	Circuit Board	28
Cleaning a Clogged Tip	13	Pressure Control	29
SHUTDOWN AND CARE	14	Pressure Control Adjustment	30
FLUSHING GUIDELINES	15	Drive Housing, Conn Rod, Crankshaft	32
TROUBLESHOOTING GUIDE		Motor	34
Motor Won't Operate	16	Displacement Pump	36
Low Output	19	PARTS DRAWINGS & LISTS	
No Output	20	Displacement Pump	39
Excessive Pressure Fluctuations	20	Upright Sprayer	40
Motor Is Hot And Runs Intermittently	21	Lo-Boy Sprayer	42
Electrical Short	21	Pressure Control	44
Spin Test	22	Wiring Diagram	45
Bridge Test	23	ACCESSORIES	46
		TECHNICAL DATA	47
		DIMENSIONS	47
		GRACO PHONE NUMBERS	47
		THE GRACO WARRANTY AND DISCLAIMERS ..	48

INTRODUCTION

ULTRA® 500 BASIC COMPONENTS

Your new sprayer functions and operates differently than other airless paint sprayers. This section will help you become familiar with the sprayer before operating it.

Pressure Control

The pressure control includes an ON/OFF switch for the sprayer, the pressure adjusting control knob, a pressure sensing device and a current overload circuit breaker with a manual reset button. The function of the pressure control is to control the motor speed so that the sprayer maintains constant fluid pressure at the pump outlet.

Motor

The DC motor has sealed bearings and replaceable motor brushes. It drives the displacement pump at the rate needed to supply sufficient paint volume at the selected pressure. Working together, the pressure control and motor cause the pump to cycle whenever there is fluid or pressure demand. When the pump is cycling, the motor sounds like an automobile starter cranking. When the pump is not cycling, the motor may hum intermittently until the fluid pressure stabilizes, then the motor will shut itself off. However, there will still be power to the sprayer and it will stay pressurized and ready to use until you manually shut it off and relieve pressure.

Because the motor is DC, it is less sensitive to low voltage or voltage fluctuations than an AC motor, and a heavy gauge extension cord of up to 150 ft. (45 m) can be used.

Drive Assembly

The sealed drive assembly transfers power from the DC motor to the displacement pump.

Displacement Pump

The positive displacement, volume-balanced pump provides equal fluid delivery on both the up and down pump strokes. The pump has a wet-cup which, when filled with Graco Throat Seal Liquid, helps prevent damage to the throat packings and piston rod.

Fluid Filter

The fluid filter strains the paint to help avoid clogs in the hose and spray tip. The filter includes a reusable element and has a pressure drain valve for manually relieving fluid pressure.

Hoses

The grounded, nylon spray hoses have spring guards on both ends. The 50 ft. (15.2 m) hose has a 1/4 in. ID. The 3 ft. (0.9 m), 3/16 in. ID hose provides more flexible gun movement. The nylon hose material acts as a pulsation dampener to absorb pressure fluctuations.

Spray Gun & RAC IV DripLess Tip Guard

Graco high pressure spray guns have a safety latch which prevents accidental triggering when it is engaged. See the Detail in Fig 3-1. The gun provided with the sprayer also has a filter for final paint straining. The Reverse-A-Clean IV SwitchTip uses high pressure fluid to remove clogs from the spray tip without removing it from the gun. The Reverse-A-Clean IV DripLess tip guard is a safety feature which helps reduce the risk of fluid injection injury.

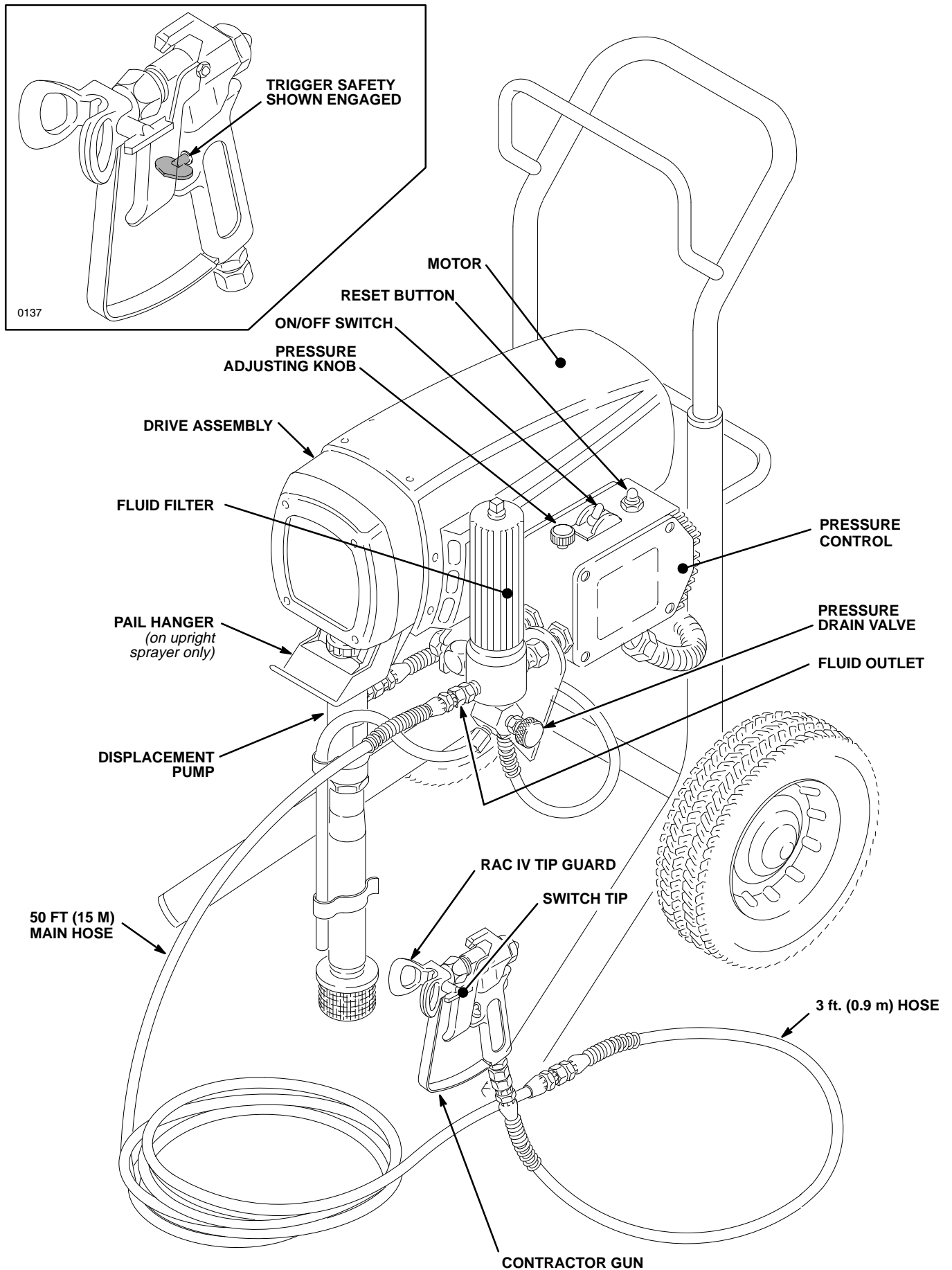

Fig 3-1

01556

SAFETY WARNINGS

**HIGH PRESSURE SPRAY CAN CAUSE SERIOUS INJURY.
FOR PROFESSIONAL USE ONLY. OBSERVE ALL WARNINGS**
Read and understand all instruction manuals before operating equipment.

FLUID INJECTION HAZARD

General Safety

This equipment generates very high fluid pressure. Spray from the gun, leaks or ruptured components can inject fluid through your skin and into your body and cause extremely serious bodily injury, including the need for amputation. Also, fluid injected or splashed into the eyes or on the skin can cause serious damage.

NEVER point the spray gun at anyone or at any part of the body. NEVER put hand or fingers over the spray tip. NEVER try to “blow back” paint; this is NOT an air spray system.

ALWAYS have the tip guard in place on the spray gun when spraying.

ALWAYS follow the **Pressure Relief Procedure**, below, before cleaning or removing the spray tip or servicing any system equipment.

NEVER try to stop or deflect leaks with your hand or body.

Be sure equipment safety devices are operating properly before each use.

Medical Alert—Airless Spray Wounds

If any fluid appears to penetrate your skin, get **EMERGENCY MEDICAL CARE AT ONCE. DO NOT TREAT AS A SIMPLE CUT.** Tell the doctor exactly what fluid was injected.

Note to Physician: Injection into the skin is a traumatic injury. It is important to treat the injury surgically as soon as possible. Do not delay treatment to research toxicity. Toxicity is a concern with some exotic coatings injected directly into the blood stream. Consultation with a plastic surgeon or reconstructive hand surgeon may be advisable.

Spray Gun Safety Devices

Be sure all gun safety devices are operating properly before each use. Do not remove or modify any part of the gun; this can cause a malfunction and result in serious bodily injury.

Safety Latch

Whenever you stop spraying, even for a moment, always set the gun safety latch in the closed or “safe” position, making the gun inoperative. Failure to set the safety latch can result in accidental triggering of the gun.

Diffuser

The gun diffuser breaks up spray and reduces the risk of fluid injection when the tip is not installed. Check diffuser operation regularly. Follow the **Pressure Relief Procedure**, below, then remove the spray tip. Aim the gun into a metal pail, holding the gun firmly to the pail. Using the lowest possible pressure, trigger the gun. If the fluid emitted *is not* diffused into an irregular stream, replace the diffuser immediately.

Tip Guard

ALWAYS have the tip guard in place on the spray gun while spraying. The tip guard alerts you to the fluid injection hazard and helps reduce, but does not prevent, the risk of accidentally placing your fingers or any part of your body close to the spray tip.

Trigger Guard

Always have the trigger guard in place on the gun when spraying to reduce the risk of accidentally triggering the gun if it is dropped or bumped.

Spray Tip Safety

Use extreme caution when cleaning or changing spray tips. If the spray tip clogs while spraying, engage the gun safety latch immediately. ALWAYS follow the **Pressure Relief Procedure** and then remove the spray tip to clean it.

NEVER wipe off build-up around the spray tip until pressure is fully relieved and the gun safety latch is engaged.

Pressure Relief Procedure

To reduce the risk of serious bodily injury, including fluid injection, splashing fluid or solvent in the eyes or on the skin, or injury from moving parts or electric shock, always follow this procedure whenever you shut off the sprayer, when checking or servicing any part of the spray system, when installing, cleaning or changing spray tips, and whenever you stop spraying.

1. Engage the gun safety latch.
2. Turn the ON/OFF switch to OFF.
3. Unplug the power supply cord.

4. Disengage the gun safety latch. Hold a metal part of the gun firmly to the side of a grounded metal pail, and trigger the gun to relieve pressure.
5. Engage the gun safety latch.
6. Open the pressure drain valve, having a container ready to catch the drainage. Leave the valve open until you are ready to spray again.

If you suspect that the spray tip or hose is completely clogged, or that pressure has not been fully relieved after following the steps above, VERY SLOWLY loosen the tip guard retaining nut or hose end coupling to relieve pressure gradually, then loosen completely. Now clear the tip or hose.

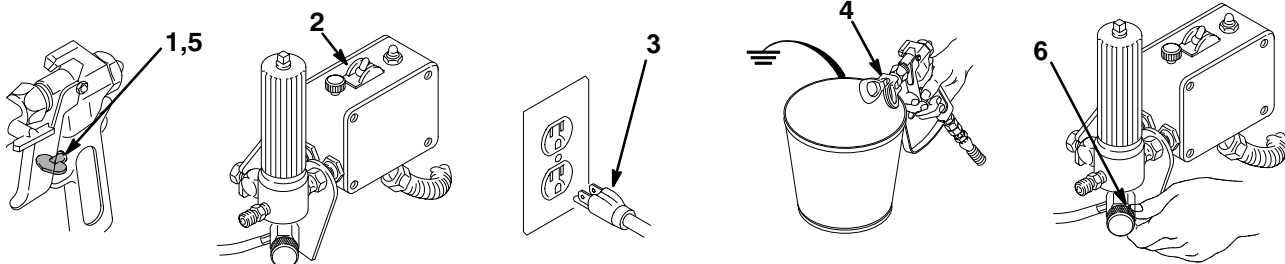

MOVING PARTS HAZARD

Moving parts can pinch or amputate your fingers or other body parts. KEEP CLEAR of moving parts when starting or operating the sprayer. Follow the **Pressure Relief Procedure** on page 2 before checking or servicing any part of the sprayer, to prevent it from starting accidentally.

EQUIPMENT MISUSE HAZARD

General Safety

Any misuse of the spray equipment or accessories, such as overpressurizing, modifying parts, using incompatible chemicals and fluids, or using worn or damaged parts, can cause them to rupture and result in fluid injection, splashing in the eyes or on the skin, or other serious bodily injury, or fire, explosion or property damage.

NEVER alter or modify any part of this equipment; doing so could cause it to malfunction.

CHECK all spray equipment regularly and repair or replace worn or damaged parts immediately.

Always wear protective eyewear, gloves, clothing and respirator as recommended by the fluid and solvent manufacturer.

System Pressure

This sprayer can develop *2750 psi (190 bar)* MAXIMUM WORKING PRESSURE. Be sure that all spray equipment and accessories used are rated to withstand this pressure. DO NOT exceed the maximum working pressure of any component or accessory used in the system.

Fluid and Solvent Compatibility

All chemicals used in the sprayer must be compatible with the wetted parts shown in the **TECHNICAL DATA** on page 47. Consult your chemical supplier to ensure compatibility.

Do not use 1,1,1-trichloroethane, methylene chloride, other halogenated hydrocarbon solvents or fluids containing such solvents in this equipment, which contains aluminum and/or zinc parts. Such use could result in a serious chemical reaction, with the possibility of explosion, which could cause death, serious bodily injury and/or substantial property damage.

FIRE OR EXPLOSION HAZARD

Static electricity is created by the flow of fluid through the pump and hose. If every part of the spray equipment is not properly grounded, sparking may occur, and the system may become hazardous. Sparking may also occur when plugging in or unplugging a power supply cord or using a gasoline engine. Sparks can ignite fumes from solvents and the fluid being sprayed, dust particles and other flammable substances, whether you are spraying indoors or outdoors, and can cause a fire or explosion and serious bodily injury and property damage.

If you experience any static sparking or even a slight shock while using this equipment, **STOP SPRAYING IMMEDIATELY**. Check the entire system for proper grounding. Do not use the system again until the problem has been identified and corrected.

Grounding

To reduce the risk of static sparking, ground the sprayer and all other spray equipment used or located in the spray area. CHECK your local electrical code for detailed grounding instructions for your area and type of equipment. BE SURE to ground all of this spray equipment:

1. *Sprayer*: connect a ground wire and clamp (supplied) to a true earth ground.

HOSE SAFETY

High pressure fluid in the hoses can be very dangerous. If the hose develops a leak, split or rupture due to any kind of wear, damage or misuse, the high pressure spray emitted from it can cause a fluid injection injury or other serious bodily injury or property damage.

ALL FLUID HOSES MUST HAVE SPRING GUARDS ON BOTH ENDS! The spring guards help protect the hose from kinks or bends at or close to the coupling which can result in hose rupture.

TIGHTEN all fluid connections securely before each use. High pressure fluid can dislodge a loose coupling or allow high pressure spray to be emitted from the coupling.

NEVER use a damaged hose. Before each use, check the entire hose for cuts, leaks, abrasion, bulging cover, or damage or movement of the hose couplings. If any of these conditions exist, replace the hose immediately. DO NOT try to recouple high pressure hose or mend it with tape or any other device. A repaired hose cannot contain the high pressure fluid.

HANDLE AND ROUTE HOSES CAREFULLY. Do not pull on hoses to move equipment. Keep hoses clear of moving parts and hot surfaces of the pump and gas engine. Do not use fluids or solvents which are not compatible with the inner tube and cover of the hose. DO NOT expose Graco hose to temperatures above 180° F (82° C) or below -40° F (-40° C).

Hose Grounding Continuity

Proper hose grounding continuity is essential to maintaining a grounded spray system. Check the electrical resistance of your fluid hoses at least once a week. If your hose does not have a tag on it which specifies the maximum electrical resistance, contact the hose supplier or manufacturer for the maximum resistance limits. Use a resistance meter in the appropriate range for your hose to check the resistance. If the resistance exceeds the recommended limits, replace it immediately. An ungrounded or poorly grounded hose can make your system hazardous. Also read **FIRE OR EXPLOSION HAZARD**.

2. *Fluid hoses*: use only grounded hoses with a maximum of 500 ft (150 m) combined hose length to ensure grounding continuity. See **Hose Grounding Continuity**.
3. *Spray gun*: obtain grounding through connection to a properly grounded fluid hose and sprayer.
4. *Object being sprayed*: according to local code.
5. *Fluid supply container*: according to local code.
6. *All solvent pails used when flushing*, according to local code. Use only metal pails, which are conductive. Do not place the pail on a non-conductive surface, such as paper or cardboard, which interrupts the grounding continuity.
7. *To maintain grounding continuity when flushing or relieving pressure*, always hold a metal part of the gun firmly to the side of a grounded metal pail, then trigger the gun.

Flushing Safety

Reduce the risk of fluid injection injury, static sparking, or splashing by following the flushing procedure given on page 15 of this manual. Follow the **Pressure Relief Procedure** on page 4, and remove the spray tip before flushing. Hold a metal part of the gun firmly to the side of a grounded metal pail and use the lowest possible fluid pressure during flushing.

IMPORTANT

United States Government safety standards have been adopted under the Occupational Safety and Health Act. These standards – particularly the General Standards, Part 1910, and the Construction Standards, Part 1926 – should be consulted.

AVERTISSEMENT

La pulvérisation à haute pression peut causer des blessures très graves.
Réservé exclusivement à l'usage professionnel. Observer toutes les consignes de sécurité.
Bien lire et bien comprendre tous les manuels d'instructions avant d'utiliser le matériel.

RISQUES D'INJECTION

Consignes générales de sécurité

Cet appareil produit un fluide à très haute pression. Le fluide pulvérisé par le pistolet ou le fluide sous pression provenant de fuites ou de ruptures peut pénétrer sous la peau ou à l'intérieur du corps et entraîner des blessures très graves, voir même une amputation. Même sans être sous pression, le fluide éclaboussant ou entrant dans les yeux peut aussi entraîner des blessures graves.

NE JAMAIS pointer le pistolet vers quelqu'un ou vers une partie quelconque du corps. NE JAMAIS mettre la main ou les doigts sur l'ajutage du pulvérisateur. NE JAMAIS essayer de "refouler" la peinture. Cet appareil N'est PAS un compresseur pneumatique.

TOUJOURS garder la protection de l'ajutage en place sur le pistolet pendant la pulvérisation.

TOUJOURS observer la **Marche à Suivre pour Détendre la Pression** donnée plus loin, avant de nettoyer ou d'enlever l'ajutage du pulvérisateur, ou d'effectuer un travail quelconque sur une partie de l'appareil.

NE JAMAIS essayer d'arrêter ou de dévier les fuites avec la main ou le corps.

Avant chaque utilisation, bien s'assurer que les dispositifs de sécurité fonctionnent correctement.

Soins médicaux

En cas de pénétration de fluide sous la peau: **DEMANDER IMMEDIATEMENT DES SOINS MEDICAUX D'URGENCE. NE PAS SOIGNER CETTE BLESSURE COMME UNE SIMPLE COUPURE.**

Avis au medecin: La pénétration des fluides sous la peau est un traumatisme. **Il est important de traiter chirurgicalement cette blessure immédiatement.** Ne pas retarder le traitement pour effectuer des recherches sur la toxicité. Certains revêtements exotiques sont dangereusement toxiques quand ils sont injectés directement dans le sang. Il est souhaitable de consulter un chirurgien esthétique ou un chirurgien spécialisé dans la reconstruction des mains.

Dispositifs de sécurité du pistolet

Avant chaque utilisation, bien s'assurer que tous les dispositifs de sécurité du pistolet fonctionnent correctement. Ne pas enlever ni modifier une partie quelconque du pistolet; ceci risquerait d'entraîner un mauvais fonctionnement et des blessures graves.

Verrou de sécurité

A chaque fois que l'on s'arrête de pulvériser, même s'il s'agit d'un court instant, toujours mettre le verrou de sécurité du pistolet sur la position "fermée" ou "sécurité" ("safe") pour empêcher le pistolet de fonctionner. Si le verrou de sécurité n'est pas mis, le pistolet peut se déclencher accidentellement. Voir la figure, ci-dessus.

Diffuser

Le diffuseur du pistolet sert à diviser le jet et à réduire les risques d'injection accidentelle quand l'ajutage n'est pas en place. Vérifier le fonctionnement du diffuseur régulièrement. Pour cette vérification, détendre la pression en observant la **Marche à Suivre pour Détendre la Pression** donnée plus loin puis enlever l'ajutage du pulvérisateur. Pointer le pistolet dans un seau en métal, en le maintenant fermement contre le seau. Puis, en utilisant la pression la plus faible possible, appuyer sur la gâchette du pistolet. Si le fluide projette *n'est pas* diffusé sous forme de jet irrégulier, remplacer immédiatement le diffuseur.

Protection de l'ajutage

TOUJOURS maintenir la protection de l'ajutage en place sur le pistolet du pulvérisateur pendant la pulvérisation. La protection de l'ajutage attire l'attention sur les risques d'injection et contribue à réduire, mais n'évite pas le risque, que les doigts ou une partie quelconque du corps ne passent accidentellement à proximité immédiate de l'ajutage du pulvérisateur.

Consignes de sécurité concernant l'ajutage du pulvérisateur

Faire extrêmement attention à l'occasion du nettoyage ou du remplacement des ajutages du pulvérisateur. Si l'ajutage se bouche pendant la pulvérisation, mettre immédiatement le verrou de sécurité du pistolet. TOUJOURS bien observer la **Marche à Suivre pour Détendre la Pression** puis enlever l'ajutage du pulvérisateur pour le nettoyer.

NE JAMAIS essayer ce qui s'est accumulé autour de l'ajutage du pulvérisateur avant que la pression ne soit complètement tombée et que le verrou de sécurité du pistolet ne soit engagé.

Marche à Suivre pour Détendre la Pression

Pour réduire les risques de blessures graves, y compris les blessures par injection de fluide ou celles causées par des éclaboussures dans les yeux ou sur la peau, des pièces en mouvement ou par électrocution, toujours bien observer cette marche à suivre à chaque fois que l'on arrête le pulvérisateur, à l'occasion de la vérification, du réglage ou du nettoyage du système ou lors du changement des ajutages.

1. Engager le verrou de sécurité du pistolet.
2. Basculer l'interrupteur de commande de pression sur ARRÊT (OFF).
3. Débrancher le cordon d'alimentation.

4. Désengager le verrou de sécurité du pistolet. Tout en maintenant une partie métallique du pistolet fermement appuyée contre le côté d'un seau en métal, actionner le pistolet pour libérer la pression.
5. Engager le verrou de sécurité du pistolet.
6. Ouvrir la soupape de sécurité et la laisser ouverte jusqu'à ce que l'on soit prêt à se servir de nouveau du pulvérisateur. Débrancher le fil de la bougie.

Si l'on soupçonne que le tuyau ou l'ajutage du est complètement bouché, ou que la pression n'a pas été complètement libérée après avoir procédé aux opérations ci-dessus, desserrer très LENTEMENT un raccord du bout du tuyau ou l'écrou de retenue de la protection de l'ajutage et libérer progressivement la pression.

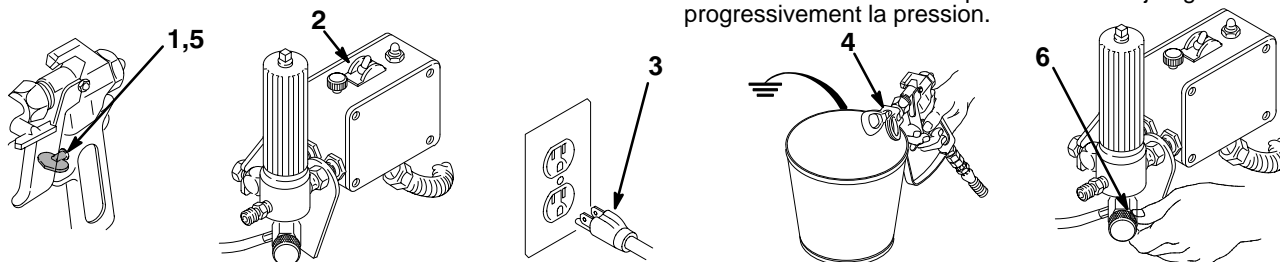

RISQUES EN CAS DE MAUVAISE UTILISATION DU MATERIEL

Consignes générales de sécurité

Toute utilisation anormale de l'appareil de pulvérisation ou des accessoires comme, par exemple, la mise sous une pression excessive, les modifications de pièces, l'utilisation de produits chimiques et de matières incompatibles et l'utilisation de pièces usées ou abîmées peut causer des dégâts à l'appareil ou des ruptures de pièces et entraîner une injection de liquide ou d'autres blessures sérieuses, un incendie, une explosion ou d'autres dégâts.

NE JAMAIS alterer ou modifier une pièce de cet appareil; ceci risquerait d'entraîner son mauvais fonctionnement.

Vérifier régulièrement tout l'appareil de pulvérisation et ses équipements et réparer ou remplacer immédiatement les pièces usées ou abîmées.

MESURES DE SÉCURITÉ CONCERNANT LES TUYAUX FLEXIBLES

Le fluide à haute pression circulant dans les tuyaux peut être très dangereux. En cas de fuite sur le tuyau, de fissure, déchirure ou rupture à la suite de l'usure, de dégâts ou d'une mauvaise utilisation, les projections de fluide haute pression qui en proviennent peuvent entraîner des blessures graves par pénétration sous la peau ou par contact, ainsi que des dégâts matériels.

TOUS LES TUYAUX FLEXIBLES DOIVENT AVOIR DES RESORTS SPIRALE DE PROTECTION AUX BOUTS! Les spirales de protection contribuent à éviter la formation de pliures, de boucles ou de nœuds sur les tuyaux qui pourraient entraîner la rupture du tuyau à l'endroit du raccord ou à son voisinage.

SERRER FERMEMENT tous les raccords avant chaque utilisation. Le fluide sous pression peut faire sauter un raccord deserre ou produire un jet à haute pression s'échappant par le raccord.

NE JAMAIS utiliser un tuyau endommagé. NE PAS essayer de refaire le raccord d'un tuyau haute pression ni de réparer le tuyau avec du ruban adhésif ou par tout autre moyen. Un tuyau réparé ne peut pas résister au fluide sous pression.

RISQUES D'INCENDIE OU D'EXPLOSION

De l'électricité statique est produite par le passage du fluide à grande vitesse dans la pompe et dans les tuyaux. Si toutes les pièces de l'appareil de pulvérisation ne sont pas convenablement reliées à la masse ou à la terre, des étincelles peuvent se produire et l'appareil risque d'être dangereux. Des étincelles peuvent également se produire à l'occasion du branchement ou du débranchement du cordon d'alimentation. Les étincelles sont suffisantes pour allumer les vapeurs de solvants et le fluide pulvérisé, les fines particules de poussière ainsi que d'autres substances inflammables, quand on pulvérise à l'intérieur ou à l'extérieur, et elles peuvent causer un incendie ou une explosion, ainsi que des blessures graves et des dégâts matériels. Toujours brancher le pulvérisateur dans une prise se trouvant à au moins 6 m (20 pieds) de l'appareil et de l'endroit où se fait la pulvérisation. Ne pas brancher ou débrancher un cordon d'alimentation quel qu'il soit dans la zone où se fait la pulvérisation quand il y a le moindre risque que des vapeurs encore présentes dans l'air prennent feu.

S'il se produit des étincelles d'électricité statique, ou si vous ressentez la moindre décharge, **ARRÊTEZ IMMÉDIATEMENT LA PULVÉRISATION**. Vérifiez que le système entier est bien mis à la terre. Ne vous servez pas du système avant que le problème soit identifié et corrigé.

Mise à la terre ou à la masse

Pour réduire les risques de production d'étincelles d'électricité statique, le pulvérisateur et tous les équipements utilisés ou se trouvant dans la zone de pulvérisation doivent être reliés à la terre ou à la masse. Pour connaître le détail des instructions de mise à la terre dans la région et le type particulier d'équipement, **CONSULTER** le code ou les réglementations électriques locales. **S'ASSURER** que tous les équipements de pulvérisation suivants sont bien reliés à la terre:

1. *Pulvérisateur*: Brancher le cordon d'alimentation ou la rallonge qui doivent être équipés d'une prise à 3 fiches en bon état, dans une prise de courant convenablement mise à la terre. Ne pas utiliser d'adaptateur. Toutes les rallonges doivent avoir 3 fils et être prévues pour 15 ampères.

Pression

Ce pulvérisateur peut produire une **PRESSION MAXIMUM DE TRAVAIL** 190 bar (2750 lb/po2). S'assurer que tous les éléments du pulvérisateur et ses accessoires sont conçus pour résister à la pression maximum de travail de ce pulvérisateur. **NE PAS** dépasser la pression maximum de travail d'aucun des éléments ou accessoires utilisés avec cet appareil.

Compatibilité chimique des corps

BIEN S'ASSURER que tous les corps des solvants utilisés sont chimiquement compatibles avec les parties mouillées indiquées dans les **Technical Data**, à page 47. Toujours lire soigneusement les documents et brochures du fabricant des fluides et solvants utilisés avant de s'en servir dans ce pulvérisateur.

MANIPULER LES TUYAUX AVEC PRECAUTION ET CHOISIR SOIGNEUSEMENT LEUR CHEMIN. Ne pas déplacer le fluide en tirant sur le tuyau. Ne pas utiliser de fluides ou de solvants qui ne sont pas compatibles avec l'enveloppe intérieure ou extérieure du tuyau. **NE PAS** exposer le tuyau à des températures supérieures à 82°C (180°F) ou inférieures à -40°C (-40°F).

Continuité de la mise à la terre des tuyaux

Une bonne continuité de la mise à la terre des tuyaux est essentielle pour maintenir la mise à la terre de l'ensemble de vaporisation. Vérifiez la résistance électrique de vos tuyaux à fluides et à air, au moins une fois par semaine. Si votre tuyau ne comporte pas d'étiquette qui précise la résistance électrique maximum, prenez contact avec le fournisseur de tuyaux ou la fabricant pour avoir les limites de résistance maximum. Utilisez un mètre de résistance de la gamme appropriée pour votre tuyau et vérifiez la résistance. Si celle-ci dépasse les limites recommandées, remplacez le tuyau immédiatement. Un tuyau sans mise à la terre ou avec une mise à la terre incorrecte peut entraîner des risques pour votre système. Lisez aussi **LES RISQUES D'INCENDIE OU D'EXPLOSION** ci-dessus.

2. *Tuyaux flexibles*: Afin d'assurer la continuité de la mise à la terre, n'utiliser que des tuyaux comportant une mise à la terre et ayant une longueur maximum combinée de 150 m (1500 pieds). Se reporter également au paragraphe **Continuité du circuit de mise à la terre des tuyaux**.
3. *Pistolet*: Réaliser la mise à la terre en le raccordant à un tuyau flexible et à un pulvérisateur déjà convenablement reliés à la terre.
4. *Récipient d'alimentation*: observer le code ou les réglementations locales.
5. *Objets, matériel ou surfaces recevant la pulvérisation*: observer le code ou les réglementations locales.
6. *Tous les seaux de solvants* utilisés pour le rinçage: observer le code ou les réglementations locales. N'utiliser que des seaux métalliques conducteurs de l'électricité. Ne pas mettre le seau sur une surface non conductrice comme sur du papier ou du carton car cela interromprait la continuité de la mise à la terre.
7. *Pour conserver la continuité de la mise à la terre quand on rince le matériel ou quand on libère la pression*, toujours maintenir une partie métallique du pistolet fermement appuyée contre le côté d'un seau en métal puis appuyer sur la détente du pistolet.

Mesures de sécurité concernant le Rinçage

Pour réduire les risques de blessures par pénétration de la peau et les risques dus aux étincelles d'électricité statique ou aux éclaboussures, observer la marche à suivre pour le rinçage donnée à la page 15 de ce manuel. Observer la "Marche à Suivre pour Détendre la Pression" donnée à la page 6 en *enlever l'ajutage du pulvérisateur avant le rinçage*. Maintenir une partie métallique du pistolet fermement appuyée contre le côté d'un seau en métal et utiliser la pression la plus faible possible pendant le rinçage.

ADVERTENCIA

EL ROCIADO a ALTA PRESIÓN PUEDE CAUSAR GRAVES LESIONES. SOLO PARA USO PROFESIONAL. RESPETE LOS AVISOS DE ADVERTENCIA.

Lea y entienda todo el manual de instrucciones antes de manejar el equipo.

PELIGRO DE INYECCIÓN DE FLUIDO

Seguridad general

Este equipo genera un fluido a una presión muy alta. El rociado de la pistola, los escapes de fluido o roturas de los componentes pueden inyectar fluido en la piel y el cuerpo y causar lesiones extremadamente graves, incluyendo a veces la necesidad de amputación. También, el fluido inyectado o salpicado en los ojos puede causar graves daños.

NUNCA apuntar la pistola hacia alguien o alguna parte del cuerpo. NUNCA colocar la mano o los dedos encima de la boquilla. NUNCA tratar de "hacer retornar la pintura"; este NO es un sistema de rociado de aire.

SIEMPRE tener colocado el protector de la boquilla en la pistola mientras se está pulverizando.

SIEMPRE seguir el procedimiento de descarga de presión, dado más abajo, antes de limpiar o sacar la boquilla o de dar servicio a cualquier equipo del sistema.

NUNCA tratar de parar o desviar los escapes con la mano o el cuerpo.

Asegurar que todos los aparatos de seguridad del equipo están funcionando bien antes de cada uso.

Tratamiento médico

Si pareciera que un poco de fluido penetró la piel, conseguir **TRATAMIENTO MÉDICO DE URGENCIA DE INMEDIATO. NO TRATAR LA HERIDA COMO UN SIMPLE CORTE.** Decir al médico exactamente cual fluido fue.

Aviso al médico: Si se llega a inyectar este fluido en la piel se causa una lesión traumática. **Es importante tratar quirúrgicamente la lesión a la brevedad posible.** No demorar el tratamiento para investigar la toxicidad. La toxicidad es algo de suma importancia en algunas pinturas exóticas cuando se inyectan directamente al torrente sanguíneo. Será conveniente consultar a un especialista en cirugía plástica o reconstructiva de las manos.

Aparatos de seguridad de la pistola pulverizadora

Asegurar que todos los aparatos protectores de la pistola están funcionando bien antes de cada uso. No sacar ni modificar ninguna pieza de la pistola pues podría causar el malfuncionamiento de la misma con las consiguientes lesiones personales.

Pestillo de seguridad

Cada vez que se deje de pulverizar, aunque sea por un breve momento, siempre colocar el pestillo de seguridad en la posición "cerrada" lo que deja la pistola inoperante. El no hacerlo puede llevar al disparo imprevisto de la pistola.

Difusor

El difusor de la pistola dispersa el chorro pulverizado y reduce el riesgo de inyección cuando no está instalada la boquilla. Revisar con regularidad el funcionamiento del difusor. Seguir el **procedimiento de descarga de presión**, dado más abajo, y después sacar la boquilla. Apuntar la pistola a un balde metálico, sosteniéndola bien firme contra el. Utilizando la presión más bajo posible, disparar la pistola. Si el fluido emitido no sale disperso en un chorro irregular, reemplazar de inmediato el difusor.

Protector de la boquilla

SIEMPRE tener el protector de la boquilla colocado en la pistola mientras se está pulverizando. Este protector llama la atención contra el peligro de inyección y ayuda a reducir, pero no evita, la colocación accidental de los dedos o cualquier otra parte del cuerpo cerca de la boquilla.

Seguridad de la boquilla pulverizadora

Tener mucho cuidado al limpiar o cambiar las boquillas. Si llega a obstruirse mientras está pulverizando, enganchar el pestillo de la pistola de inmediato. SIEMPRE seguir el **procedimiento de descarga de presión** y después sacar la boquilla para limpiarla.

NUNCA limpiar la acumulación de pintura alrededor de la boquilla antes de que se haya descargado por completo la presión y el pestillo este enganchado.

Procedimiento de descarga de presión

Para reducir el riesgo de sufrir graves lesiones corporales, incluyendo inyección o lesiones causadas por piezas en movimiento o choque eléctrico, siempre seguir este procedimiento al apagar la máquina pulverizadora, al revisar o dar servicio a cualquier parte del sistema de pulverización, al instalar, limpiar o cambiar las boquillas, y cada vez que se deja de pulverizar.

1. Enganchar el pestillo de la pistola.
2. Mover el interruptor eléctrico (ON/OFF) a la posición OFF (apagado).
3. Desenchufar el cordón eléctrico.
4. Desenganchar el pestillo de la pistola. Sujetar una parte metálica de la pistola bien firme contra un balde de metal, y disparar la pistola para descargar la presión.

5. Enganchar el pestillo de la pistola.

6. Abrir la válvula de presión y tener listo un recipiente para recibir la pintura. Dejar la válvula de alivio de presión abierta hasta que se este nuevamente listo para pulverizar.

Si se sospecha que la boquilla o la manguera está completamente obstruida, o que no se ha descargado por completo la presión después de haber seguido el procedimiento anterior, aflojar MUY LENTAMENTE la tuerca de retención del protector de la boquilla o acoplamiento de la punta de la manguera y descargar gradualmente la presión, después, aflojarlo por completo. Luego, despejar la boquilla o la manguera.

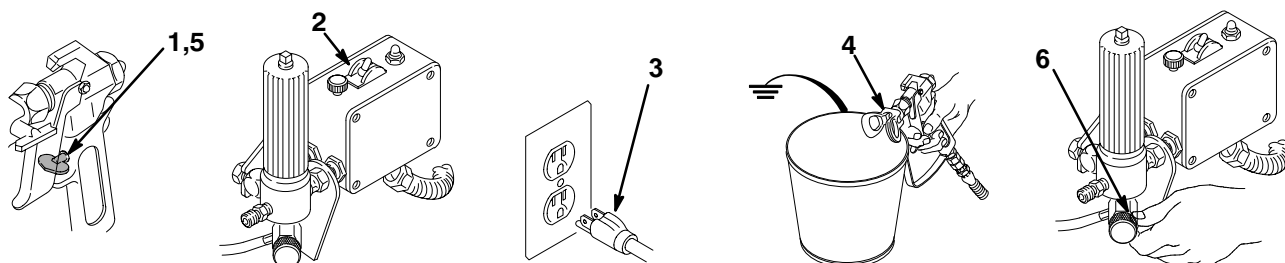

PELIGRO POR MAL USO DEL EQUIPO

Seguridad general

Cualquier mal uso del equipo pulverizador o los accesorios, tal como sobre presurización, modificación de piezas, uso de materiales y productos químicos incompatibles, o utilización de piezas dañadas o desgastadas, puede hacer que se rompan y causen la inyección de fluido u otras lesiones corporales graves, incendio, explosión o daño a la propiedad.

NUNCA alterar o modificar ninguna pieza de este equipo; el hacerlo podría causar una avería.

REVISAR con regularidad el equipo pulverizador y reparar o reemplazar de inmediato las piezas dañadas o desgastadas.

SEGURIDAD EN EL USO DE LAS MANGUERAS

El fluido que escapa a alta presión por las mangueras puede ser muy peligroso. Si en la manguera se desarrolla un escape, una rotura o rajadura debido a cualquier tipo de desgaste, daño o maltrato, el chorro a alta presión emitido por allí puede causar una lesión por inyección u otras lesiones corporales graves o daños a la propiedad.

¡TODAS LAS MANGUERAS PARA FLUIDOS TIENEN QUE TENER GUARDAS DE RESORTE EN AMBOS EXTREMOS!

Estas protegen las mangueras contra dobleces o retorceduras en los acoplamientos o cerca de ellos, los que podrían traducirse en roturas de la manguera.

Antes de usarlas, APRETAR bien firmes todas las conexiones. El fluido a alta presión puede desalojar un acoplamiento suelto o dejar que por el escape un chorro a alta presión.

NUNCA usar una manguera que está dañada. Siempre, revisarla en busca de cortaduras, escapes, abrasión, cubierta abultada, o acoplamientos sueltos o dañados. Si llegara a encontrarse cualquiera de estas condiciones, reemplazar de inmediato la manguera. NO intentar racoplar una manguera de alta presión o enmendarla con cinta adhesiva u otro material similar. Una manguera que ha sido remendada no aguante el fluido a alta presión.

PELIGRO DE INCENDIO O EXPLOSION

El flujo a alta velocidad del fluido al pasar por la bomba y manguera crea electricidad estática. Si todas las partes del equipo pulverizador no tienen buena tierra, pueden ocurrir chispas, convirtiendo al sistema en algo peligroso. También, pueden producirse chispas al enchufar o desenchufar el cordón eléctrico o al usar un motor de gasolina. Estas chispas pueden inflamar los vapores de los solventes y el chorro de fluido pulverizado, partículas de polvo y otras sustancias inflamables, sea al aire libre o bajo techo, lo que podría causar una explosión o incendio y graves lesiones corporales y daños a la propiedad. Enchufar siempre la pulverizadora a un tomacorriente que se encuentre a por lo menos 6 m (20 pies) de la máquina y del área que se va a rociar. No enchufar o desenchufar ningún cordón eléctrico en el lugar donde se está rociando cuando todavía exista la posibilidad de que queden vapores inflamables en el aire.

Si ocurre una chispa de electricidad estática o incluso un ligero choque eléctrico mientras se usa el equipo, DEJAR DE PULVERIZAR DE INMEDIATO. Revisar todo el sistema en busca de una tierra apropiada. No usar de nuevo el sistema hasta haber identificado y solucionado el problema.

Peusta a tierra

Para reducir el riesgo de chispas estáticas, conectar a tierra la pulverizadora y todo el otro equipo de pulverizar que se use o se encuentre en el lugar que se va a rociar. CONSULTAR el código eléctrico de la localidad para las instrucciones sobre las conexiones a tierra exigidas para la zona y tipo de equipo. ASEGURAR de conectar a tierra todo este equipo pulverizador:

1. *Pulverizadora:* enchufar el cordón eléctrico, o cable extensor, cada uno un enchuf de tres patas en buen estado, a un tomacorriente con puestas a tierra apropiado. No usar un adaptador. Todos los cables extensores tienen que tener tres hilos y una capacidad de 15 amperios.

Presión del sistema

Está pulverizadora puede desarrollar 190 barías (2750 psi) de presión DE TRABAJO MÁXIMA. Asegurar que todo el equipo pulverizador y sus accesorios tienen la capacidad para aguantar la presión máxima de trabajo de esta pulverizadora. NO exceder la presión máxima de trabajo de ningún componente o accesorio de este sistema.

Compatibilidad de fluido

Siempre leer las instrucciones del fabricante del fluido y solvente antes de usarlos en esta pulverizadora, dadas en la página 47.

Siempre usar gafas, guantes, vestimentas protectora y un respiradero, tal como recomiendan los fabricantes del fluido y del solvente.

MANEJAR Y PASAR CUIDADOSAMENTE LAS MANGUERAS. No tirar de las mangueras para mover el equipo. No usar fluidos o solventes que sean incompatibles con el tubo interno y la cubierta de la manguera. NO exponer las mangueras a temperaturas sobre 82°C (180°F) o bajo -40°C (-40°F).

Continuidad del circuito de puesta a tierra de la manguera

La continuidad del circuito de puesta a tierra apropiado es esencial para mantener conectado a tierra el sistema pulverizador. Es indispensable revisar la resistencia eléctrica máxima de las mangueras de aire y de fluido por lo menos una vez a la semana. Si la manguera no tiene una etiqueta en la cual se especifica la resistencia eléctrica, ponerse en contacto con el proveedor o fabricante de la manguera para la información sobre los límites de resistencia. Usar un metro de resistencia en la gama apropiada para comprobar la resistencia; si excede los límites recomendados, reemplazarla de inmediato. Es muy arriesgado tener una manguera sin puesta a tierra o con la puesta a tierra en malas condiciones. Leer también la información sobre **RIESGO DE INCENDIO O EXPLOSION**, más arriba.

2. *Mangueras para fluidos:* usar solamente mangueras con puesta a tierra de una longitud combinada de 150 m (500 pies), para asegurar buena continuidad a tierra. Referirse también al párrafo sobre **continuidad a tierra de la manguera**.
3. *Pistola:* hace la puesta a tierra conectándola a una manguera de fluido y pulverizadora bien conectadas a tierra.
4. *Suministrar un recipiente:* de acuerdo al código de la localidad.
5. *Objeto que se está rociando:* de conformidad con el código local.
6. *Todos los baldes de solvente* usados durante el lavado, de conformidad con el código local. Usar *solamente baldes de metal*, que sean conductivos. no colocar el balde en una superficie no conductiva, como papel o cartón, que interumpe la continuidad a tierra.
7. *Para mantener la continuidad a tierra durante el lavado o descarga de presión,* siempre apoyar una parte metálica de la pistola bien firme contra el costado del *balde de metal*, después apretar el gatillo.

Seguridad durante el lavado

Para reducir el riesgo de que se inyecte o salpique fluido en la piel, o que ocurra una descarga de electricidad estática, siempre seguir las INSTRUCCIONES PARA EL LAVADO, dadas en la página 15. Seguir el **procedimiento de descarga de presión** en la página 8, y quitar la *boquilla rociadora antes de lavar*. Apoyar una parte metálica de la pistola bien firme contra el costado de un *balde de metal* y usar la presión más baja posible de fluido durante el lavado.

SETUP

WARNING

To reduce the risk of serious bodily injury from static sparking, fluid injection, or over pressurization and rupture of the hose or gun, all hoses must be electrically conductive, the gun must have a tip guard, and each part must be rated for at least 2750 psi (195 bar) Maximum Working Pressure.

CAUTION

To avoid damaging the pressure control, which may result in poor equipment performance and component damage, follow these precautions:

1. Always use grounded, flexible spray hose at least 50 ft. (15 m) long.
2. Never use a wire braid hose as it is too rigid to act as a pulsation dampener.
3. Never install any shutoff device between the filter and the main hose. See Fig 11-1.
4. Always use the main filter outlet. Never plug this outlet.

WARNING

Proper electrical grounding is essential to reduce the risk of fire or explosion which can result in serious bodily injury and property damage. Read the warning section **FIRE OR EXPLOSION HAZARD** on page 5 for more detailed grounding instructions.

NOTE: See Fig 11-1 while doing the setup.

1. **Fill the packing nut/wet-cup** 1/3 full with Graco Throat Seal Liquid (TSL), supplied.
2. **Connect the gun, 3 ft. hose and 50 ft. hose.** Screw the assembly onto the outlet nipple. Don't use thread sealant and don't install the spray tip yet!
3. **Check the electrical service.**
 - a. Electrical requirements: 120 V, 60 HzAC, 15 Amp (minimum).
 - b. Use a grounded electrical outlet located at least 20 ft. (6 m) from the spray area.
 - b. Do not remove the grounding prong of the power supply cord and do not use an adapter.
 - c. Extension cord specifications: 15 Amps, 3 wires, grounding type. (Long lengths reduce sprayer performance.)
5. **Plug in the sprayer.** Turn the ON/OFF switch OFF. Plug the cord into a grounded electrical.
6. **Flush the pump** to remove the oil left in to protect pump parts after factory testing. See the **FLUSHING GUIDELINES** on page 15.
7. **Prepare the paint** according to the manufacturer's recommendations. Remove any paint skin. Stir the paint thoroughly. Strain the paint through a fine nylon mesh bag to remove particles that could clog the filter or spray tip.

SETUP

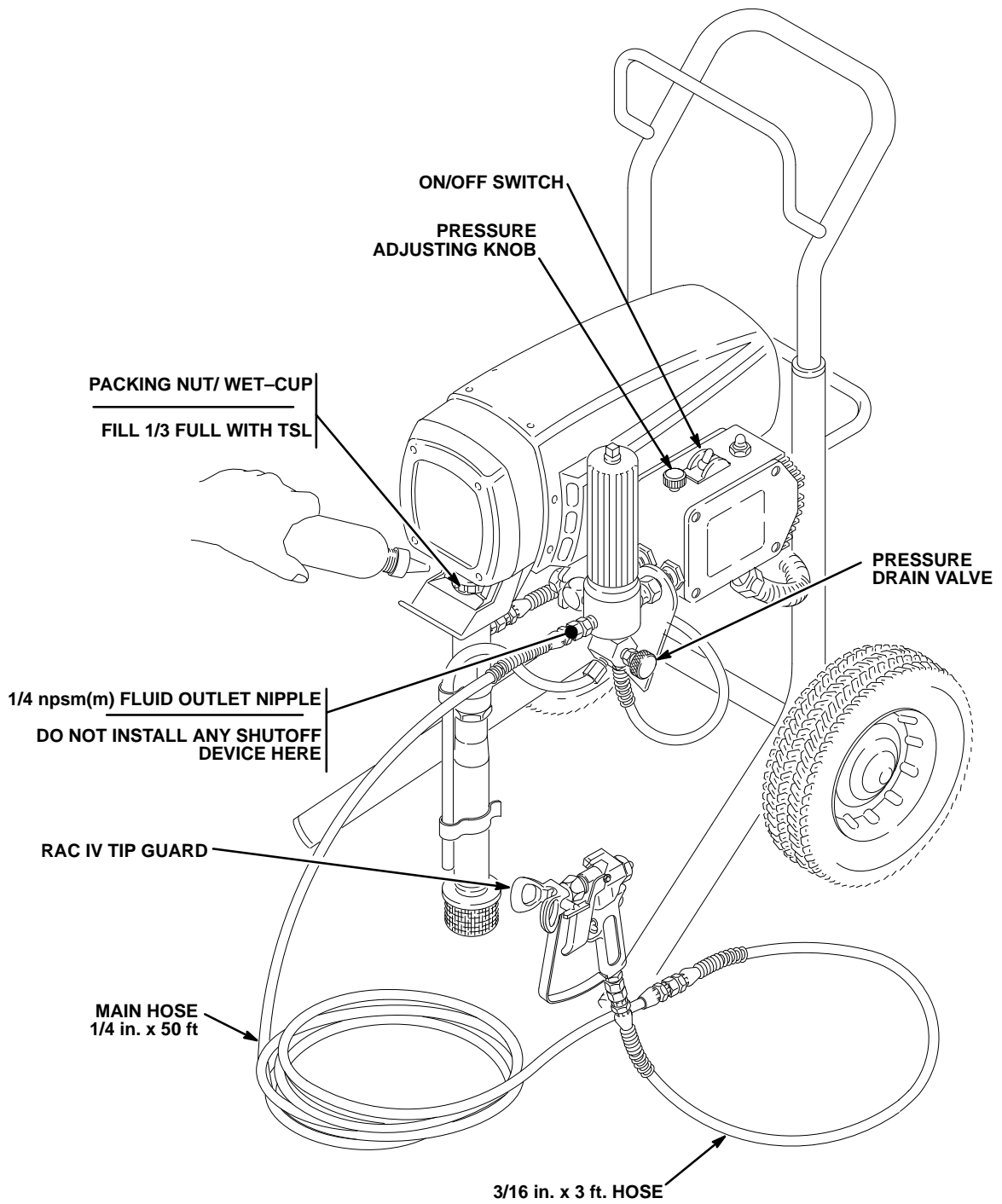

Fig 11-1

01556

OPERATION

Use this procedure each time you start the sprayer to help ensure the sprayer is ready to operate and that you start it safely.

WARNING

To reduce the risk of serious injury, follow the illustrated **Pressure Relief Procedure** warning on page 4 whenever you are instructed to relieve pressure.

NOTE: Flush the sprayer if this is a first-time startup. See page 15.

NOTE: See Fig 12–2 except where noted.

1. **Plug in the sprayer.**
2. **Close the pressure drain valve.**
3. **Put the suction tube into the paint container.**
4. **Turn the pressure adjusting knob fully counter-clockwise to minimum pressure.**

CAUTION

Do not run the pump without fluid in it for more than 30 seconds to avoid damage to the displacement pump packings.

WARNING

To reduce the risk of static sparking and splashing when flushing, always remove the spray tip from the gun and hold a metal part of the gun firmly to the side of a grounded metal pail.

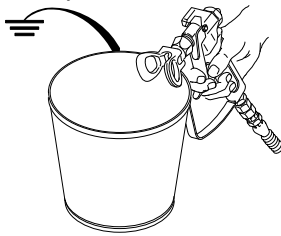

6. **Prime the pump.**
 - a. Open the pressure drain valve. Turn on the sprayer. Slowly turn the pressure adjusting knob clockwise until the sprayer starts. When fluid comes from the drain hose, close the valve.
 - b. Disengage the gun safety latch. See Fig 12–1. Following the warning, above, trigger the gun until all air is forced out of the system and the paint flows freely from the gun.
 - c. Release the trigger. Engage the gun safety latch.
7. **Check all fluid connections for leaks.** Relieve the fluid pressure before tightening connections.
8. **Install the spray tip and tip guard.** Engage the gun safety latch. See Fig 12–1. Install the spray tip according to the instructions supplied with it.

9. Adjust the spray pattern

- a. Increase the pressure just until spray from the gun is completely atomized. Use the lowest pressure needed to get the desired results. This reduces over spray and fogging, decreases tip wear and extends the life of the sprayer.
- b. If more coverage is needed, use a larger tip rather than increasing the pressure.
- c. Test the spray pattern. To adjust the pattern, engage the gun safety latch, loosen the retaining nut. Position the tip guard horizontally for a horizontal pattern or vertically for a vertical pattern. Then tighten the retaining nut.

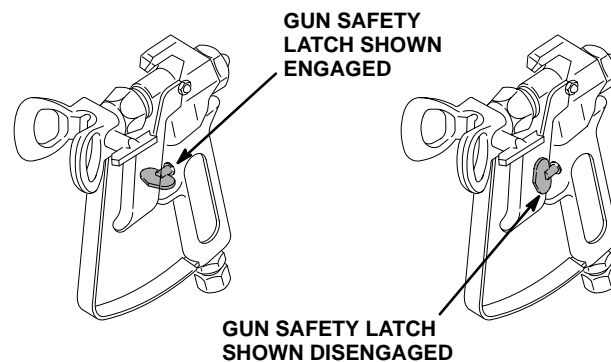

Fig 12–1

0137

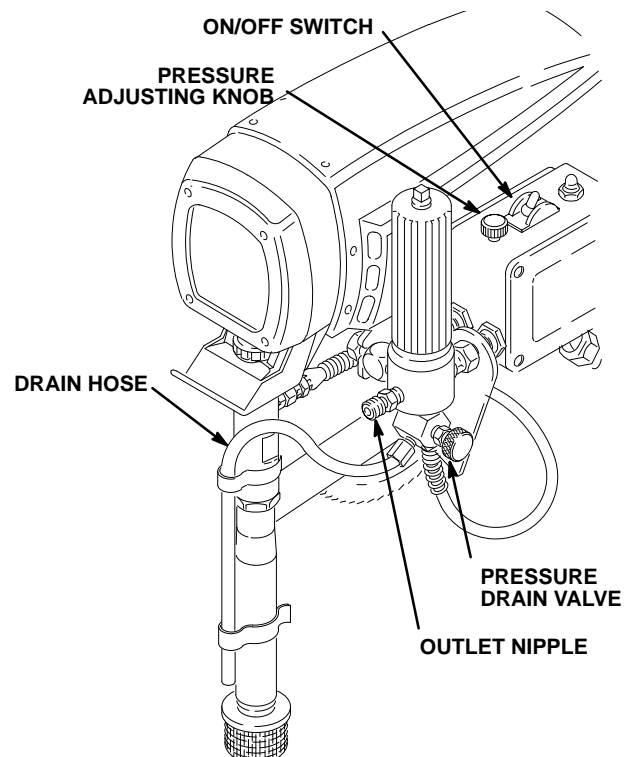

Fig 12–2

01566

Cleaning a Clogged Tip

WARNING

To reduce the risk of serious injury, follow the illustrated **Pressure Relief Procedure** warning on page 4 whenever you are instructed to relieve pressure.

WARNING

To reduce the risk of serious bodily injury from fluid injection:

NEVER operate the spray gun with the tip guard removed.

DO NOT hold your hand, body, or a rag in front of the spray tip when cleaning or checking a clogged tip. Always point the gun toward the ground or into a pail when checking to see if the tip is clear.

DO NOT try to “blow back” paint; this is NOT an air spray sprayer.

1. Clean the front of the tip frequently during the day’s operation. First, relieve pressure.
2. If the spray tip does clog, release the gun trigger, engage the gun safety latch, and rotate the RAC IV handle 180°. See Fig 13–1.

3. Disengage the gun safety latch and trigger the gun into a waste container. Engage the gun safety latch again.
4. Return the handle to the original position, disengage the gun safety latch, and resume spraying.
5. If the tip is still clogged, engage the gun safety latch, shut off and unplug the sprayer, and open the pressure drain valve to relieve pressure. Clean the spray tip as shown in manual 307–848, supplied with the RAC IV.

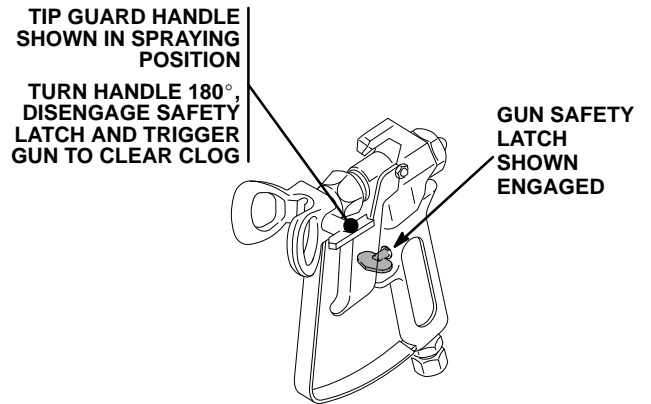

Fig 13–1

0137

SHUTDOWN AND CARE

WARNING

To reduce the risk of serious injury, follow the illustrated **Pressure Relief Procedure** warning on page 4 whenever you are instructed to relieve pressure.

1. **Check the packing nut/wet-cup daily.** First relieve pressure. Keep the wet-cup 1/3 full of TSL at all times to help prevent fluid buildup on the piston rod and premature wear of packings.

Tighten the packing nut just enough to stop leakage. Over tightening causes binding and excessive packing wear. Use a round punch or brass rod and light hammer to adjust the nut. Refer to Fig 14-1.

2. **Clean the fluid filter often** and whenever the sprayer is stored. Follow the Flushing Guidelines on page 15 or refer to manual 307-273, supplied, for the cleaning procedure.
3. **Lubricate the bearing housing** after every 100 hours of operation. First relieve pressure. Remove the front cover. Fill the bearing housing cavity with SAE 10 non-detergent oil. See Fig 14-2.
4. **For very short shutoff periods,** leave the suction tube in the paint, relieve pressure, and clean the spray tip.
5. **Flush the sprayer at the end of each work day** and fill it with mineral spirits to help prevent pump corrosion and freezing. See page 15.

CAUTION

To prevent pump corrosion, and to reduce the chance of fluid freezing in the pump or pressure control in cold weather, never leave water or any type of paint in the sprayer when it is not in use. Freezing can seriously damage the sprayer or result in a loss of pressure or stalling.

6. **Coil the hose and hang it on the hose rack** when storing it, even for overnight, to help protect the hose from kinking, abrasion, coupling damage, etc.

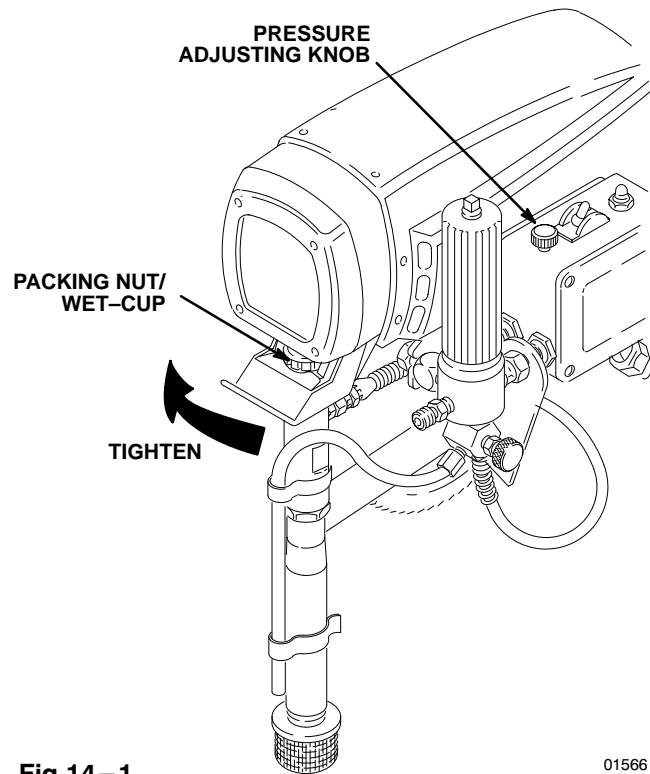

Fig 14-1

01566

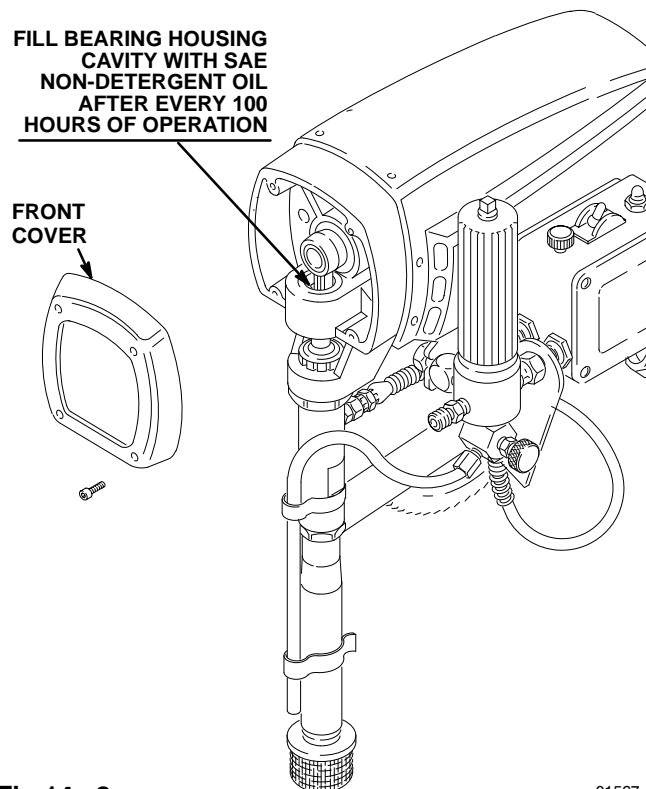

Fig 14-2

01567

FLUSHING GUIDELINES

NOTE: Several flushes are often required to thoroughly clean the system and prepare it for the next fluid to be sprayed, or to store the sprayer. Use this chart to determine the required flushing order for the fluid you are using, and then follow the procedure below for flushing.

*Use this category for flushing a brand new sprayer and flushing after storage.

System has this fluid in it:	Next fluid to be sprayed.	Flushing order:			Before you spray or store sprayer:
		Flush 1	Flush 2	Flush 3	
*Oil-based solvent or paint	Oil-based paint – new color	Mineral spirits	none	none	Prime with oil-based paint
Oil-based solvent or paint	Water-based paint	Mineral spirits	Warm soapy water	Clean water	Prime with water-based paint
Oil-based solvent or paint	Prepare for storage	Mineral spirits	none	none	Relieve pressure, Leave drain valve open
Water or water-based paint	Water-based paint – new color	Warm soapy water	Clean water	none	Prime with water
Water or water-based paint	Oil-based paint	Warm soapy water	Clean water	Mineral spirits	Prime with oil
Water or water-based paint	Prepare for storage	Warm soapy water	Clean water	Mineral spirits	Relieve pressure, Leave drain valve open

CAUTION

NEVER allow water to freeze in the pressure control. Doing so prevents the sprayer from being started and causes serious damage to the pressure control. Pump the water out with mineral spirits.

WARNING

To reduce the risk of static sparking and splashing when flushing, always remove the spray tip from the gun and hold a metal part of the gun firmly to the side of a grounded metal pail.

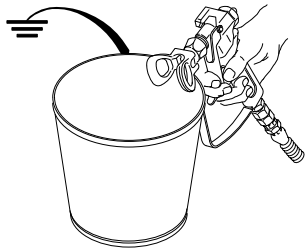

0143

1. Follow the illustrated **Pressure Relief Procedure** on page 4. Engage the gun safety latch.
2. Turn the pressure adjusting knob fully counterclockwise to the minimum pressure.
3. Remove the spray tip from the gun. Remove the filter bowl and screen; see manual 307–273. Clean the screen separately and install the bowl without the screen to flush it. See Fig 15–1.
4. Put the suction tube into a grounded metal pail with 1/2 gallon of compatible solvent.

5. Start the sprayer. See page 12. To save the fluid still in the sprayer, trigger the gun into another container until the next fluid appears, then trigger the gun back into the fluid you are pumping. Circulate the flushing fluid a couple of minutes to thoroughly clean the system.
6. Do not run the pump dry for more than 30 seconds to avoid damaging the pump packings!
7. Follow the illustrated **Pressure Relief Procedure** on page 4. Engage the gun safety latch.
8. Unscrew the filter bowl and reinstall the clean screen. Install the bowl and hand tighten.

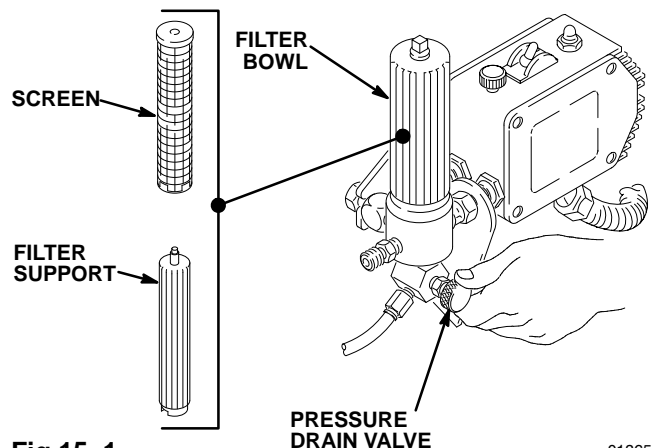

Fig 15–1

01365

TROUBLESHOOTING GUIDE

WARNING

Pressure Relief Procedure

To reduce the risk of serious bodily injury, including fluid injection, injury from splashing fluid or solvent in the eyes or on the skin, moving parts or electric shock, always follow this procedure whenever you shut off the sprayer, when checking or servicing any part of the spray system, when installing, cleaning or changing spray tips, and whenever you stop spraying.

1. Engage the gun safety latch.
2. Turn the ON/OFF switch to OFF.
3. Unplug the power supply cord.
4. Disengage the gun safety latch. Hold a metal part of the gun firmly to a grounded metal pail. Trigger the gun to relieve pressure.

5. Engage the gun safety latch.
6. Open the pressure drain valve, having a container ready to catch the drainage. Leave the pressure drain valve open until you are ready to spray again.

If you suspect that the spray tip or hose is completely clogged, or that pressure has not been fully relieved after following the steps above, VERY SLOWLY loosen the tip guard retaining nut or hose end coupling to relieve pressure gradually, then loosen completely. Now clear the tip or hose obstruction.

Check everything in the guide before disassembling the pump.

MOTOR WON'T OPERATE

TYPE OF PROBLEM	WHAT TO CHECK <i>If check is OK, go to next check</i>	WHAT TO DO <i>When check is not OK refer to this column</i>
Basic Fluid Pressure Problems	1. Check the pressure control knob setting. The motor will not run if it is at the minimum setting (fully counterclockwise).	1. Slowly increase the pressure setting to see if the motor starts.
	2. Check for a clogged spray tip. Refer to the separate gun or tip instruction manual.	2. Relieve pressure, refer to the separate gun or tip instruction manual for tip cleaning.
Basic Mechanical Problems	1. Check for frozen or hardened paint in the pump (74) and/or pressure control tube. Using a screwdriver, carefully try to rotate fan at back of motor by hand. See page 22.	1. Thaw. Plug in sprayer and turn on. Slowly increase pressure setting to see if motor starts. If it doesn't, see NOTE 1, below.
	2. Check displacement pump connecting rod pin (43). It must be completely pushed into connecting rod (70) and retaining spring (42) must be firmly in groove of connecting rod. See Fig 38-3.	2. Push pin into place and secure with the spring retainer.
	3. Check for motor damage. Remove drive housing assembly (73). See page 33. Try to rotate fan by hand.	3. Replace motor (75) if fan won't turn. See page 34.
Basic Electrical Problems	1. Check sprayer circuit breaker (309) button to be sure it has not popped up.	1. Depress button to reset. If circuit breaker continues to open, see 'Electrical Short' on page 21.
	2. Check electrical supply with volt meter. Meter should read 105-125 VAC.	2. Reset building circuit breaker; replace building fuse. Try another outlet.
	3. Check extension cord for visible damage. Use a volt meter or test lamp at extension cord outlet to check.	3. Replace extension cord.
	4. Check sprayer power supply cord (311) for visible damage such as broken insulation or wires.	4. Replace power supply cord. See page 20.
	5. Check motor brush leads, terminals and brush length. Brush length should be 1/2" minimum. See page 25.	5. Tighten terminal screws; replace brushes. See page 25.

NOTE 1: Thaw the sprayer if water or water-based paint has frozen in it, due to exposure to low temperatures, by placing it in a warm area. Do not try to start the sprayer until it has thawed completely. If the bourdon tube was not damaged by the freezing, the pump should operate. If paint hardened (dried) in the sprayer, the pump packings and/or bare pressure control must be replaced. See page 36 (pump) or 29 (pressure control).

MOTOR WON'T OPERATE

TYPE OF PROBLEM	WHAT TO CHECK <i>If check is OK, go to next check</i>	WHAT TO DO <i>When check is not OK refer to this column</i>
<p>Diagnosing circuit board indicator lamps. The normal condition is red lamp on, clear lamp on when board is telling pump to run.</p> <p>Follow Pressure Relief Procedure Warning. Remove gun from hose. Remove pressure control cover. Check for faulty condition of circuit board lamps.</p> <p>Condition A Both lamps on; pump won't operate and motor is not running</p>	<ol style="list-style-type: none"> 1. Check leads from bridge (308) to motor to be sure they are securely fastened and properly mated. 2. Check G1 and G2 connections between circuit board (72) and bridge (308) for damage or loose terminals. 3. Check for loose motor brush lead connections and terminals. See page 25. 4. Check brush length which should be 1/2" minimum. See page 25. <p>NOTE: The brushes do not wear at the same rate on both sides of the motor. Check both brushes.</p> <ol style="list-style-type: none"> 5. Check for broken or misaligned motor brush springs. Rolled portion of spring must rest squarely on top of brush. See page 25. 6. Check motor brushes for binding in brush holders. See page 25. 7. Check motor armature commutator for burn spots, gouges and extreme roughness. Remove motor cover and brush inspection plates to check. See page 25. 8. Check motor armature for shorts using armature tester (growler) or perform spin test. See page 22. 9. Check bridge (308) by substituting with a good bridge or performing bridge test. See page 23. <p>CAUTION: Do not perform this check until motor armature is determined to be good. A bad motor armature will immediately burn out a good bridge.</p>	<ol style="list-style-type: none"> 1. Replace loose terminals; crimp to leads. Be sure male terminal blades are straight and firmly connected to mating part. 2. Clean circuit board male terminals. Replace loose or damaged terminals. Securely reconnect leads. 3. Tighten terminal screws. Replace brushes if leads are damaged. See page 25. 4. Replace brushes. See page 25. 5. Replace spring if broken. Realign spring with brush. See page 25. 6. Clean brush holders. Remove carbon with small cleaning brush. Align brush leads with slot in brush holder to assure free vertical brush movement. 7. Remove motor and have motor shop resurface commutator if possible. See page 34. 8. Replace motor. See page 34. 9. Replace bridge. See page 23.
<p>Condition B (continued) Both lamps off</p> <p><i>REFER TO THE WIRING DIAGRAM ON PAGE 18 TO IDENTIFY TP POINTS.</i></p> <p>NOTE: Connect the volt meter to the <u>terminal</u> not the wire which you disconnect from the terminal.</p>	<ol style="list-style-type: none"> 1. Check circuit breaker (309) button to be sure it has not popped up. 2. Check power supply cord (311). Disconnect TP6 female (neutral) and TP1 female and connect volt meter to these leads. Plug in sprayer. Meter should read 105 to 125 VAC. Unplug sprayer. Reconnect TP1. 3. Check ON/OFF switch (303). Disconnect TP2 and connect volt meter to TP6 female and TP2 male. Plug in sprayer and turn ON. Meter should read 105 to 125 VAC. Turn off and unplug sprayer. Reconnect TP2. 4. Check jumper wire (306). Disconnect TP3 and connect volt meter to TP6 female and TP3 female. Plug in sprayer and turn on. Meter should read 105 to 125 VAC. Turn off and unplug sprayer. Reconnect TP3. 5. Check circuit breaker (309). Connect volt meter to TP6 female and TP4. Plug in sprayer and turn ON. Meter should read 105 to 125 VAC. Turn off and unplug sprayer. 	<ol style="list-style-type: none"> 1. Depress button to reset. If circuit breaker or fuse continues to open, see "Electrical Short", page 21. 2. Replace power supply cord. See page 26. 3. Replace ON/OFF switch. See page 26. 4. Replace jumper wire. See page 26. 5. Replace circuit breaker. See page 27.

MOTOR WON'T OPERATE

TYPE OF PROBLEM	WHAT TO CHECK <i>If check is OK, go to next check</i>	WHAT TO DO <i>When check is not OK refer to this column</i>
Condition B (continued) Both lamps off	6. Check motor thermal cutout switch. Connect volt meter to TP6 female and TP9 female. Plug in sprayer and turn on. Meter should read 105 to 125 VAC. Turn off and unplug sprayer.	6. Allow motor to cool. Correct cause of over-heating. If switch remains open after motor cools, check continuity between TP9 female and TP10 with ohmmeter. If open, replace motor.
REFER TO THE WIRING DIAGRAM BELOW TO IDENTIFY TP POINTS.	7. Check microswitch (302). Reconnect TP6 connectors. Connect volt meter to TP15 male and TP4. Meter should read 50–125 VAC.	7. Clean microswitch male terminals. Replace loose or damaged terminals. Securely reconnect leads.
	8. Visually inspect microswitch (302) button. Adjustment stud should not depress button when fluid pressure is zero. Depress button with small screwdriver; audible click indicates microswitch is in normal position.	8. Microswitch is faulty. Return sprayer for repair.
	9. Check microswitch (302) continuity with ohm meter. <i>Be sure sprayer is unplugged!</i> Meter should read zero ohms with no fluid pressure in the sprayer.	9. Microswitch is faulty. Return sprayer for repair.
	10. Check all terminals for damage or loose fit. Reconnect TP6 connectors.	10. Replace damaged terminals and reconnect securely.
	11. Check circuit board (72) by substituting with a good board. See page 28.	11. Replace circuit board. See page 28.

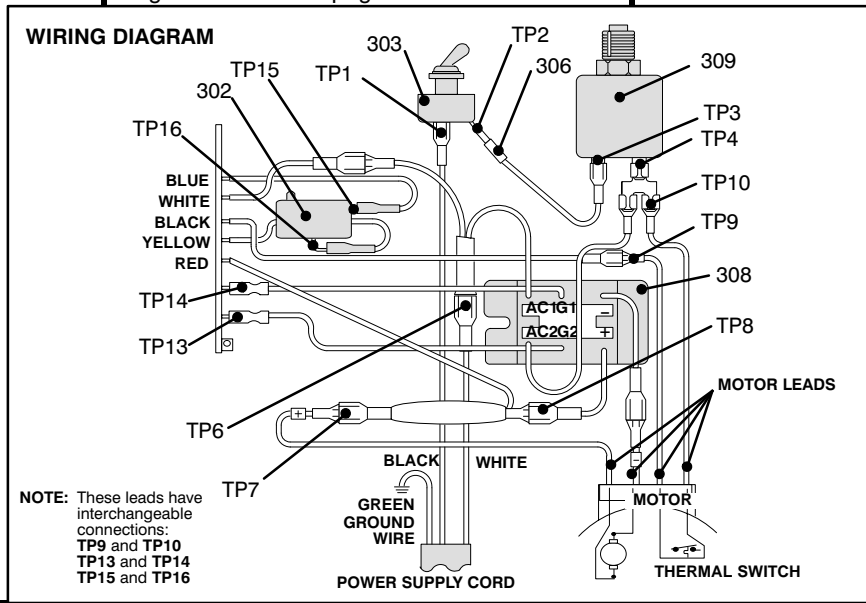

Condition C Red lamps on, Clear lamp off <i>Unplug sprayer!</i>	1. Check circuit board (72) by removing from box <i>without</i> disconnecting wires; see page 28 for removal procedure. WARNING: Removing circuit board while still wired over-rides optical detector which may cause sprayer to over-pressurize, if microswitch does not function properly. Turn sprayer on <i>ONLY</i> long enough to check lamp condition, then shut off immediately. WARNING: To reduce risk of electric shock, handle board by edges only! Do not allow any metal objects to come in contact with board! Plug in and turn on sprayer. Clear lamp should be on now. Turn off and unplug sprayer.	1. Replace circuit board. See page 28.
	2. Check bourdon tube flag and detector position. Reinstall circuit board (see page 28). Turn pressure setting to maximum; flag should extend less than half way into optical detector slot from the bottom.	2. Perform pressure control adjustment to see if that corrects problem. See page 30. If not, replace bare pressure control. See page 29.

LOW OUTPUT

TYPE OF PROBLEM	WHAT TO CHECK <i>If check is OK, go to next check</i>	WHAT TO DO <i>When check is not OK refer to this column</i>
Low Output	1. Check for worn spray tip.	1. Follow Pressure Relief Procedure Warning then replace tip. See your separate gun or tip manual.
	2. Check to see that pump does not continue to stroke when gun trigger is released. Plug in and turn on sprayer. Prime with paint. Trigger gun momentarily, then release and engage safety latch. Relieve pressure, turn off and unplug sprayer.	2. Service pump. See pages 36.
	3. Check electrical supply with volt meter. Meter should read 105–125 VAC.	3. Reset building circuit breaker; replace building fuse. Repair electrical outlet or try another outlet.
	4. Check extension cord size and length.	4. Replace with a larger wire size cord.
	5. Check G1 and G2 leads from bridge (308) to circuit board (72) for damaged or loose wires or connectors. Refer to the WIRING DIAGRAM on Fig 27–1.	5. Clean circuit board male terminals. Replace loose or defective lead terminals. Securely reconnect lead terminals to board.
	6. Check stall pressure. Refer to Pressure Control Adjustment on page 30.	6. Perform Pressure Control Adjustment. See page 30.
	7. Check bridge (308) + and – leads and terminals to motor. Inspect wiring insulation and terminals for signs of overheating. See page 27.	7. Be sure male terminal blades are centered and firmly connected to female terminals. Replace any loose terminal or damaged wiring. Securely reconnect wires to bridge.
	8. Check for loose motor brush leads and terminals. See page 25.	8. Tighten terminal screws. Replace brushes if leads are damaged. See page 25.
	9. Check for worn motor brushes which should be 1/2" minimum. See page 25.	9. Replace brushes. See page 25.
	10. Check for broken and misaligned motor brush springs. Rolled portion of spring must rest squarely on top of brush.	10. Replace spring if broken. Realign spring with brush. See page 25.
	11. Check motor brushes for binding in brush holders. See page 25.	11. Clean brush holders, remove carbon dust with small cleaning brush. Align brush lead with slot in brush holder to assure free vertical brush movement.
	12. Check circuit board (72) by substituting with a good circuit board. See page 28.	12. Replace circuit board. See page 28.
	13. Check motor armature for shorts by using an armature tester (growler) or perform spin test. See page 22.	13. Replace motor. See page 34.
	14. Check bridge (308) by substituting with a good bridge or by performing the bridge test. See page 23. CAUTION: Do not perform this check until armature is determined to be good. A bad armature will immediately burn out a good bridge.	14. Replace bridge. See page 27.

NO OUTPUT

TYPE OF PROBLEM	WHAT TO CHECK <i>If check is OK, go to next check</i>	WHAT TO DO <i>When check is not OK refer to this column</i>
Motor runs and pump strokes	1. Check paint supply.	1. Refill and reprime pump.
	2. Check for clogged intake strainer.	2. Remove and clean, then reinstall.
	3. Check for loose suction tube or fittings.	3. Tighten; use thread sealant or sealing tape on threads if necessary.
	4. Check to see if intake valve ball and piston ball are seating properly. See page 36.	4. Remove intake valve and clean. Check balls and seats for nicks; replace if necessary. See page 36. Strain paint before using to remove particles that could clog the pump.
	5. Check for leaking around throat packing nut which may indicate worn or damaged packings. See page 36.	5. Replace packings. See page 36. Also check piston valve seat for hardened paint or nicks and replace if necessary. Tighten the packing nut/wet-cup.
Motor runs but pump does not stroke	1. Check displacement pump connecting rod pin (43). See page 38.	1. Replace pin if missing. Be sure retainer spring (42) is fully in groove all around connecting rod. See page 38.
	2. Check connecting rod assembly (70) for damage. See page 32.	2. Replace connecting rod assembly. See page 32.
	3. Be sure crank in drive housing rotates; plug in sprayer and turn on briefly to check. Turn off and unplug sprayer. See page 33.	3. Check drive housing assembly for damage and replace if necessary. See page 33.

EXCESSIVE PRESSURE FLUCTUATIONS

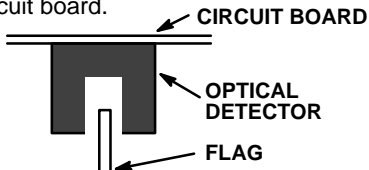
TYPE OF PROBLEM	WHAT TO CHECK <i>If check is OK, go to next check</i>	WHAT TO DO <i>When check is not OK refer to this column</i>
Spray pattern variations.	1. Be sure both G1 and G2 leads from bridge (308) to circuit board (72) are firmly connected. See Fig 27-1.	1. Reconnect securely. See page 27.
	2. Check maximum working pressure adjustment. Refer to Pressure Control Adjustment on page 30.	2. Perform Pressure Control Adjustment. See page 30.
	3. Check bourdon tube flag and detector position. Turn pressure setting to maximum; flag should not drag or bind in optical detector slot of circuit board.	3. Carefully bend flag into alignment with detector slot to see if that corrects problem. If not, replace bare pressure control assembly (77). Perform pressure control adjustment after reassembly.
		
	4. Check circuit board (72) by substituting with a good board. See page 28.	4. Replace circuit board. See page 28.
5. Check LOW OUTPUT section, page 19.		

MOTOR IS HOT AND RUNS INTERMITTENTLY

TYPE OF PROBLEM	WHAT TO CHECK <i>If check is OK, go to next check</i>	WHAT TO DO <i>When check is not OK refer to this column</i>
	1. Determine if sprayer was operated at high pressure with small tips, which causes low motor RPM and excessive heat build up.	1. Decrease pressure setting or increase tip size.
	2. Be sure ambient temperature where sprayer is located is no more than 90°F and sprayer is not located in direct sun.	2. Move sprayer to shaded, cooler area, if possible.
	3. Determine if was sprayer turned on, pressurized, but not operating for long periods of time.	3 Turn off sprayer whenever you stop spraying for a while and relieve fluid pressure.

ELECTRICAL SHORT

TYPE OF PROBLEM	WHAT TO CHECK <i>If check is OK, go to next check</i>	WHAT TO DO <i>When check is not OK refer to this column</i>
Building circuit breaker opens as soon as sprayer switch is turned on. CAUTION Any short in any part of the motor power circuit, which is connected to the output side of the bridge, will cause the bridge to burn out immediately. Correctly diagnose and repair all shorts before checking and replacing bridge.	1. Check all electrical wiring for damaged insulation, and all terminals for loose fit or damage. Also check wires between pressure control and motor which are encased in conduit (1). See page 34. 2. Check for missing inspection plate gasket (see page 25), bent terminal forks or other metal to metal contact points which could cause a short. 3. Check motor armature for shorts. Use an armature tester (growler) or perform spin test. See page 22. Inspect windings for burns. 4. Check bridge (308) by substituting with a good bridge or by performing bridge test. See pages 23 or 27. CAUTION: Do not check bridge until armature is determined to be good. A bad armature will immediately burn out a good bridge.	1. Repair or replace any damaged wiring or terminals. Securely reconnect all wires. 2. Correct faulty conditions. 3. Replace motor. See page 34. 4. Replace bridge. See page 27.
Building circuit breaker opens as soon as sprayer is plugged into outlet and sprayer is NOT turned on.	1. Check 'Basic Electrical Problems' on page 16. 2. Check ON/OFF switch (303) See page 26. <i>Be sure the sprayer is unplugged!</i> Disconnect wires from switch. Check switch with ohmmeter. The reading should be infinity with the ON/OFF switch OFF, and zero with the switch ON. CAUTION: A short in the motor circuit burns the bridge out immediately, which usually causes the ON/OFF switch to fail in the closed mode.	2. Replace ON/OFF switch. See page 26.
Sprayer circuit breaker opens after sprayer operates for 5 to 10 minutes.	1. Check electrical supply with volt meter. Meter should read 105 to 125 VAC. 2. Check tightness of pump packing nut. Over-tightening tightens packings on rod, restricts pump action, and damages packings. 3. Check maximum working pressure adjustment. 4. After determining that there is no short in system, reset circuit breaker button.	1. If voltage is too high, do not operate sprayer until corrected. 2. Loosen packing nut. Check for leaking around throat. Replace pump packings, if necessary. See page 36. 3. Perform Pressure Control Adjustment. See page 30. 4. If circuit breaker continues to open (button pops up), replace the circuit breaker. See page 27.

SPIN TEST

WARNING

To reduce the risk of serious injury, follow the illustrated **Pressure Relief Procedure** warning on page 24 whenever you are instructed to relieve pressure.

Armature, Brushes, and Motor Wiring Open Circuit Test (Continuity)

Relieve pressure. Connect the two black motor leads together with a test lead. Turn the motor fan by hand at about two revolutions per second.

If there is uneven or no turning resistance, check the following: broken brush springs, brush leads, motor leads; loose brush terminal screws, motor lead terminals; worn brushes. Repair parts as needed. See page 25.

If there is still uneven or no turning resistance, replace the motor. See page 34.

For checking armature, motor winding and brush electrical continuity.

Setup

Relieve pressure. Remove the drive housing. See page 33.

Remove the pressure control cover, the motor shield (58), the fan cover (F) and the inspection covers (J). See Fig 22-1.

Disconnect the two leads from the motor to the bridge (308). See Fig 22-2.

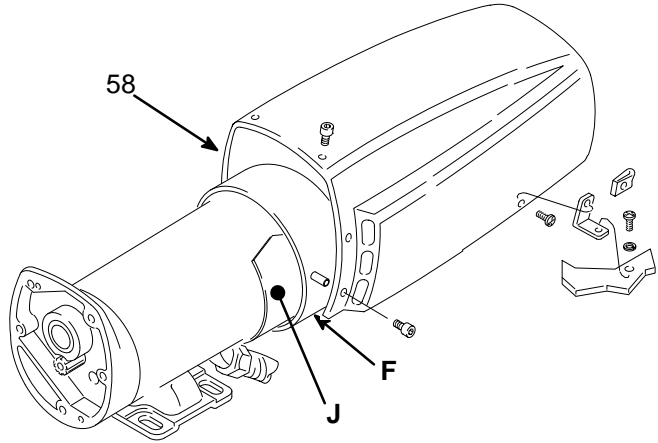

Fig 22-1

01577

Armature Short Circuit Test

Relieve pressure. Quickly turn the motor fan by hand. If there are no shorts, the motor will coast two or three revolutions before coming to a complete stop. If the motor does not spin freely, the armature is shorted and the motor must be replaced. See page 34.

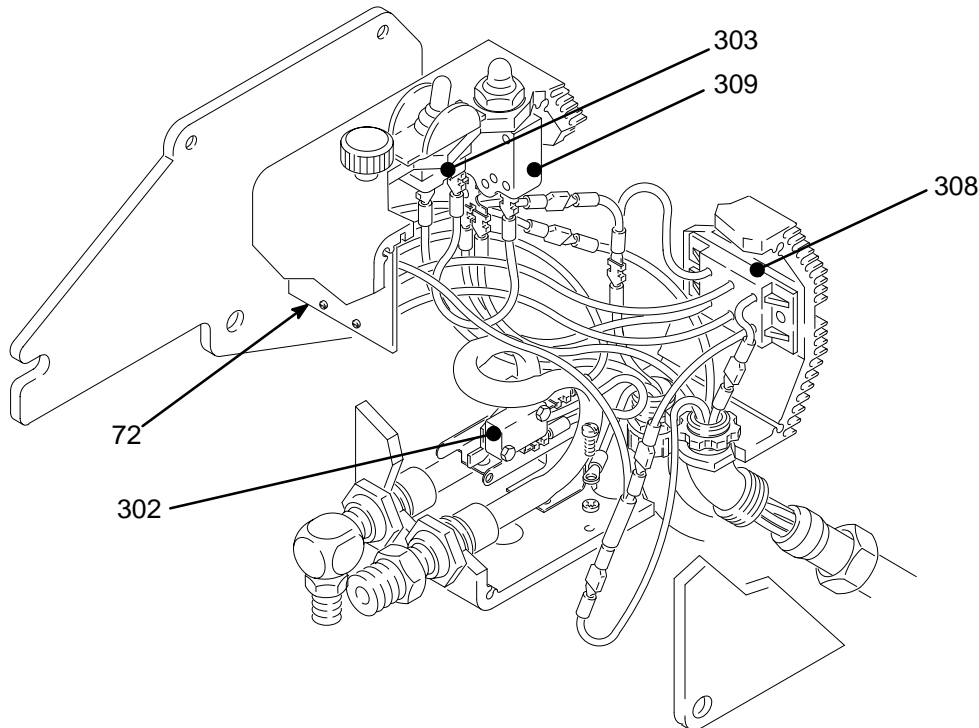

Fig 22-2

01225

BRIDGE TEST

WARNING

To reduce the risk of serious injury, follow the illustrated **Pressure Relief Procedure** warning on page 24 whenever you are instructed to relieve pressure.

Remove the bridge from the pressure control box and perform this test to determine if the bridge is functional. See **BRIDGE RECTIFIER REPLACEMENT**, page 27. Use a continuity tester, such as multi-meter set on the X1 ohms scale.

Perform all tests in the chart. If the bridge fails even one test, it must be replaced.

Fig 23-1 shows the position of the wires on the bridge. Using the chart at the right, connect the meter wires as indicated by the black dots for each test, and then check the continuity.

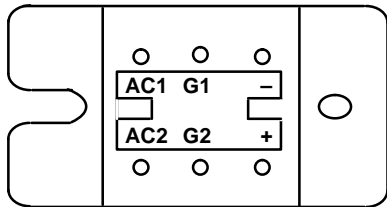

Fig 23-1

In Tests 1, 2 and 3, there should be NO continuity.

In Tests 4, 5 and 6, connect the + and - meter wires as indicated, check continuity, then switch the meter wire connections and check continuity again. You should get NO continuity one way and YES continuity the other way.

In Tests 7 and 8, connect the meter wires as indicated by the black dots. Touch the indicated "G" wire to one meter wire, and then to the other. You should get NO continuity one way and YES continuity the other way.

BRIDGE WIRES

CONTINUITY	G2	G1	-	+	AC1	AC2	
NO					•	•	TEST 1
NO				•		•	TEST 2
NO				•	•		TEST 3
YES NO							TEST 4
YES NO							TEST 5
YES NO							TEST 6
YES NO		○	OR	•	•		TEST 7
YES NO	○	OR	•	•			TEST 8

WARNING

Pressure Relief Procedure

To reduce the risk of serious bodily injury, including fluid injection, splashing fluid or solvent in the eyes or on the skin, or injury from moving parts or electric shock, always follow this procedure whenever you shut off the sprayer, when checking or servicing any part of the spray system, when installing, cleaning or changing spray tips, and whenever you stop spraying.

1. Engage the gun safety latch.
2. Turn the ON/OFF switch to OFF.
3. Unplug the power supply cord.

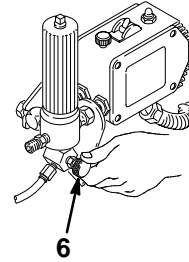
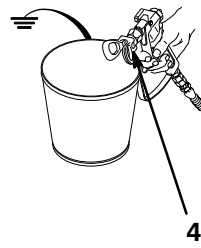
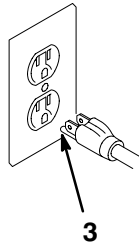
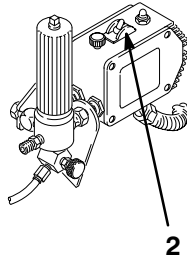
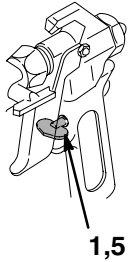

4. Disengage the gun safety latch. Hold a metal part of the gun firmly to the side of a grounded metal pail, and trigger the gun to relieve pressure.
5. Engage the gun safety latch.
6. Open the pressure drain valve, having a container ready to catch the drainage. Leave the valve open until you are ready to spray again.

If you suspect that the spray tip or hose is completely clogged, or that pressure has not been fully relieved after following the steps above, VERY SLOWLY loosen the tip guard retaining nut or hose coupling to relieve pressure gradually, then loosen completely. Now clear the tip or hose.

01361

CAUTION

To reduce the risk of a pressure control malfunction:

- Always use needle nose pliers to disconnect a wire.
- Mate wire connectors properly. Be sure the flat blade of the insulated male connector is centered in the wrap-around blade of the female connector.
- Route wires carefully through the center of the U-shaped bourdon tube to avoid interference with the movement of the bourdon tube. Also avoid interference from the circuit board and between the pressure control and cover.

WARNING

To reduce the risk of serious bodily injury, including electric shock, DO NOT touch any moving parts or electrical parts with your fingers or a tool while inspecting the repair.

Shut off the sprayer and unplug it as soon as you complete the inspection.

Reinstall all covers, gaskets, screws and washers before operating the sprayer.

3. **If the sprayer does not operate properly**, review the repair procedure again to verify that everything was done correctly. If necessary, see the Troubleshooting Guide, pages 16–21, to help identify other possible problems and solutions.

Tool List

Phillips screwdriver	1/4 in. hex key wrench
Small flat blade screwdriver	3/16 in. hex key wrench
Needle nose pliers	5/8 in. socket wrench
Plastic mallet	3/8 in. open end wrench
Adjustable wrench	1/2 in. open end wrench
Adjustable, open-end wrench	3/4 in. open end wrench
Torque wrench	7/8 in. open end wrench
	High quality motor oil
	Bearing grease

1. **Keep all screws, nuts, washers, gaskets, and electrical fittings** removed during repair procedures. These parts are not normally provided with replacement assemblies.
2. **Test your repair before regular operation** of the sprayer to be sure the problem is corrected.

CAUTION

Do not run the sprayer dry for more than 30 seconds to avoid damaging the pump packings.

4. **Reinstall the motor shield before regular operation** of the sprayer and replace it if it is damaged. The cover directs cooling air around the motor to help prevent overheating. It can also help reduce the risk of burns, fire or explosion; see the **WARNING**, below.

WARNING

During operation, the motor and drive housing become very hot and could burn your skin if touched. Flammable materials spilled on the hot, bare motor could cause a fire or explosion. Always have the motor shield in place during regular operation to reduce the risk of burns, fire or explosion.

MOTOR BRUSH REPLACEMENT

NOTE: Replace the brushes when they have worn to less than 1/2 in. See STEP 1, Fig 25-3. Note that the brushes wear differently on each side of the motor, so check them both. Brush Repair Kit 220-853 is available. A new spring clip, P/N 110-816 may be purchased separately.

WARNING

To reduce the risk of serious injury, follow the illustrated **Pressure Relief Procedure** warning on page 24 whenever you are instructed to relieve pressure.

NOTE: Read the GENERAL REPAIR INFORMATION on page 24 before doing this procedure.

1. Relieve pressure.
2. Remove the motor shield (58). Remove the inspection covers (J) and gaskets (K) on each side of the motor. See Fig 25-1.

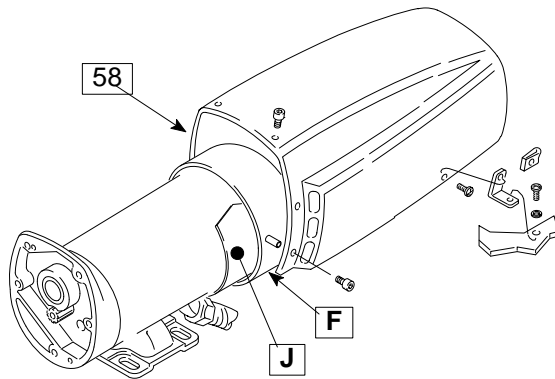

Fig 25-1

01577

3. Push in the spring clip to release its hooks from the brush holder. Pull out the spring clip. See Fig 25-2.
4. Loosen the brush lead terminal screw. Pull the brush lead away, leaving the motor lead terminal in place. Remove the brush and spring. See Fig 25-3.
5. Inspect the commutator for excessive pitting, burning or gouging. A black color on the commutator is normal. Have the commutator resurfaced by a qualified motor repair shop if the brushes seem to wear too fast.

CAUTION

When installing the brushes, follow all steps carefully to avoid damaging the parts.

6. Install a new brush so the lead is in the long slot of the holder. See Fig 25-4.
7. Slide the terminal under the terminal screw washer and tighten the screw. Be sure the motor lead is still connected at the screw. See Fig 25-3.
8. Place the spring on the brush as shown in Fig 25-4.
9. Install the spring clip and push it down to hook the short slots in the housing. See Fig 25-4.
10. Repeat for the other side.

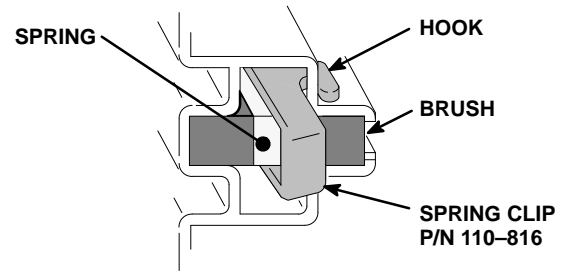

Fig 25-2

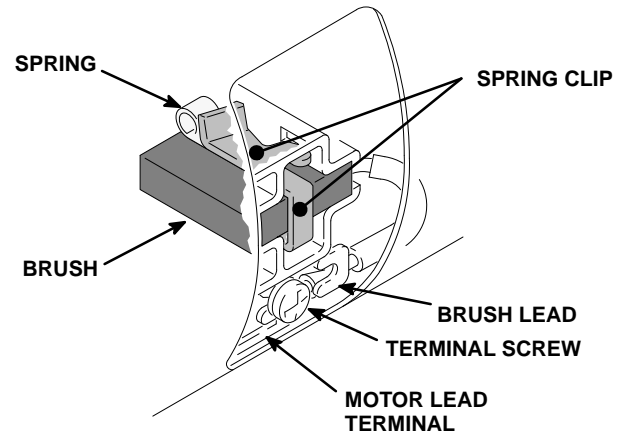

Fig 25-3

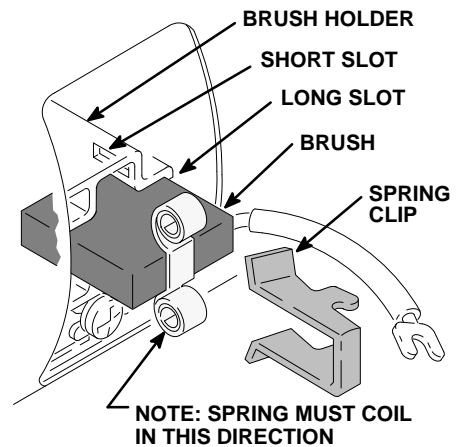

Fig 25-4

01227

WARNING

Do not touch the brushes, leads, springs or brush holders while the sprayer is plugged in to reduce the risk of electric shock and serious bodily injury.

CAUTION

Do not run the sprayer dry for more than 30 seconds while checking the brushes to avoid damaging the displacement pump packings.

11. **Test the brushes.** With the sprayer OFF, turn the pressure control knob to minimum pressure. Plug in the sprayer. Turn the sprayer ON. Slowly increase the pressure until the motor comes up to full speed. Inspect the brush and commutator contact area for excessive arcing. Arcs should not "trail" or circle around the commutator surface.
12. Install the remaining parts.

POWER SUPPLY CORD REPLACEMENT

WARNING

To reduce the risk of serious injury, follow the illustrated **Pressure Relief Procedure** warning on page 24 whenever you are instructed to relieve pressure.

NOTE: Read the GENERAL REPAIR INFORMATION on page 24 before doing this procedure.

NOTE: Refer to Fig 26-1 for this procedure.

1. Relieve pressure.
2. Remove the pressure control cover (62).
3. Disconnect the power supply cord lead from the ON/OFF switch (303), the white wire going to the bridge (308), and the green wire to the grounding screw (343).
4. Loosen the strain relief bushing (328). Remove the power supply cord (311).
5. Install the new cord (311) in the reverse order.

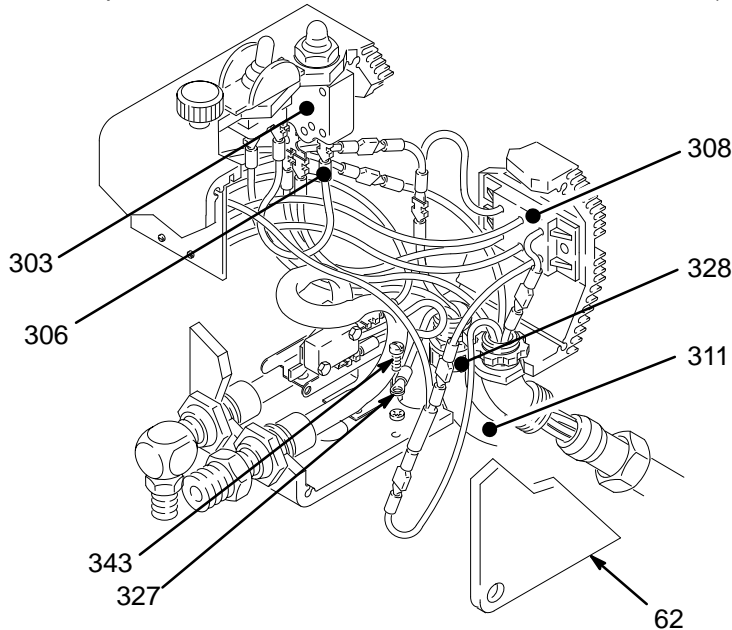

Fig 26-1

01225

ON/OFF SWITCH REPLACEMENT

WARNING

To reduce the risk of serious injury, follow the illustrated **Pressure Relief Procedure** warning on page 24 whenever you are instructed to relieve pressure.

NOTE: Read the GENERAL REPAIR INFORMATION on page 24 before doing this procedure.

NOTE: Refer to Fig 26-2 for this procedure.

7. Install the switch guard (305), aligning the internal tab with the groove in the threads.
8. Powder the inside of the rubber boot (304) with talcum powder, then shake the excess out of the boot.
9. Install the nut and rubber boot and tighten.
10. Reconnect all wires.

1. Relieve pressure.
2. Remove the pressure control cover (62).
3. Disconnect the upper terminal wire from the micro-switch (302) and the two black wires from the ON/OFF switch (303). See Fig 26-1.
4. Using a 5/8 in. socket wrench, remove the nut and rubber boot (304). Remove the switch guard (305).
5. Remove the ON/OFF switch (303)
6. Install the new switch so the internal tab of the anti-rotation ring (W) engages with the vertical groove in the threads of the switch, and the external tab engages with the blind hole (D) of the pressure control box.

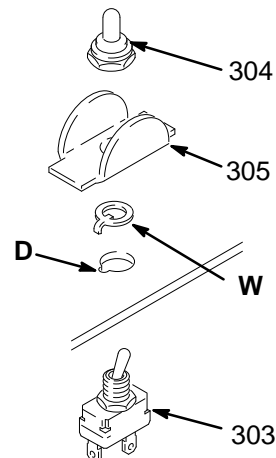

Fig 26-2

01228

BRIDGE RECTIFIER REPLACEMENT

WARNING

To reduce the risk of serious injury, follow the **Pressure Relief Procedure** warning on page 24 whenever you are instructed to relieve pressure.

NOTE: Read the GENERAL REPAIR INFORMATION on page 24 before doing this procedure.

NOTE: *The most common cause of bridge failure is a faulty motor.* Check the motor before replacing the bridge to prevent damaging the new bridge.

NOTE: Refer to Fig 27-1 for this procedure.

1. Relieve pressure.

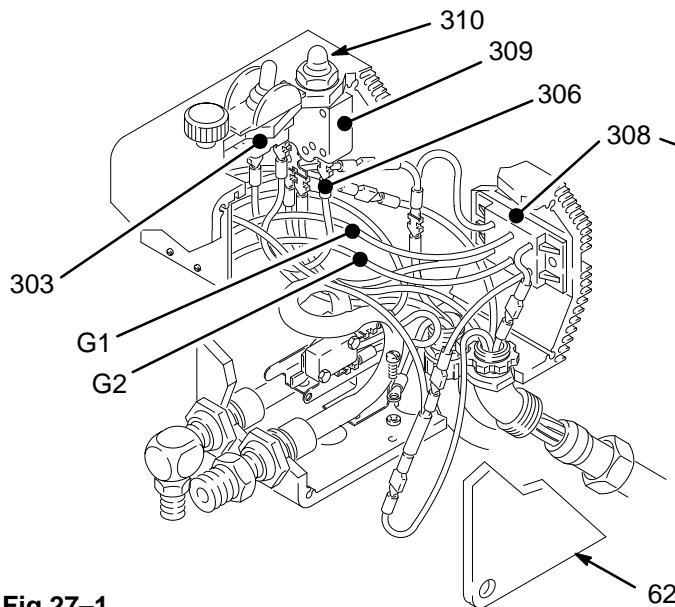

Fig 27-1

2. Remove the pressure control cover (62).
3. Disconnect all wires from the bridge (308).
4. Loosen but don't remove the screw (331A). Remove the screw (331B). Slide the bridge out.
5. Slide in the new bridge (308). Be sure the lockwashers (333) are IN FRONT of the bridge. Tighten the screws (331) securely.

CAUTION

The lockwashers (333) must be in front of the bridge to avoid overheating which will result in bridge failure. See the DETAIL in Fig 27-1.

6. Connect all wires properly and route them carefully.

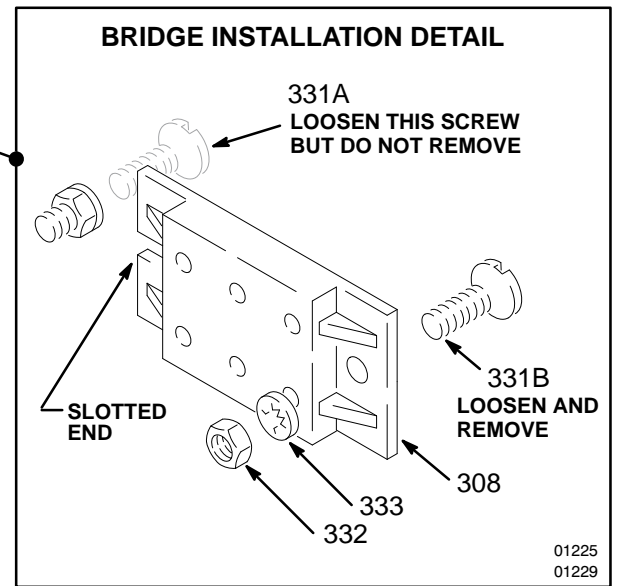

01225
01229

CIRCUIT BREAKER REPLACEMENT

WARNING

To reduce the risk of serious injury, follow the **Pressure Relief Procedure** warning on page 24 whenever you are instructed to relieve pressure.

NOTE: Read the GENERAL REPAIR INFORMATION on page 24 before doing this procedure.

NOTE: Refer to Fig 27-1 for this procedure.

1. Remove the pressure control cover (62).
2. Use a small screwdriver to slide the terminal adapter off the circuit breaker terminal.

3. Disconnect the single black wire (306) between the circuit breaker (309) to the ON/OFF switch (303).
4. Use a 5/8 in. socket wrench to loosen the nut and boot (310) on the circuit breaker button.
5. Push down on the top of the circuit breaker (309) and pull it out of the box.
6. Install the new circuit breaker in the reverse order.

CAUTION

Do not allow the circuit breaker contacts to touch the bourdon tube, which will cause a short. Tighten the circuit breaker nut firmly to prevent the circuit breaker from turning.

CIRCUIT BOARD REPLACEMENT

WARNING

To reduce the risk of serious injury, follow the illustrated **Pressure Relief Procedure** warning on page 24 whenever you are instructed to relieve pressure.

NOTE: Read the GENERAL REPAIR INFORMATION on page 24 before doing this procedure.

NOTE: Refer to Fig 28-1 and 28-2 for this procedure.

1. Relieve pressure.
2. Remove the pressure control cover.
3. Turn the pressure control knob to the minimum setting to release spring tension on the board. Check to be sure only three or four threads of the pressure control knob shaft are exposed below the pressure adjustment nut (S). Loosen the nut, if necessary.

CAUTION

Step 2 is essential to reduce the risk of damaging the circuit board while removing or installing it.

4. Disconnect all seven wires from the board. Pay close attention to where connections are made.

5. Pull out the plastic-tipped pin (330). Push the bottom of the circuit board (72) toward the wall of the pressure control and carefully slide the board out.
6. Reinstall the new board in the pressure control at the same angle as it was removed.
7. Reconnect all wires. Ease the pin (330) into the retainer.
8. Perform the **PRESSURE CONTROL ADJUSTMENT**, page 30, if you installed a new board.

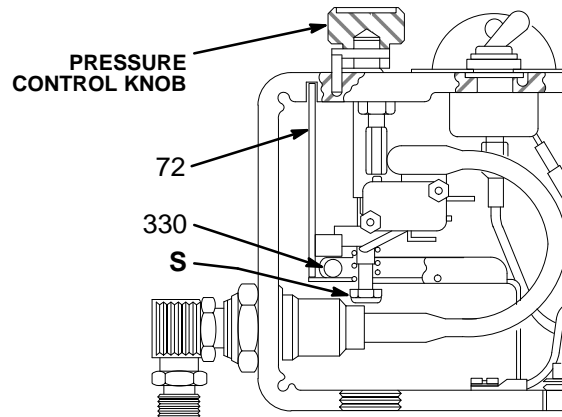

Fig 28-1

01230

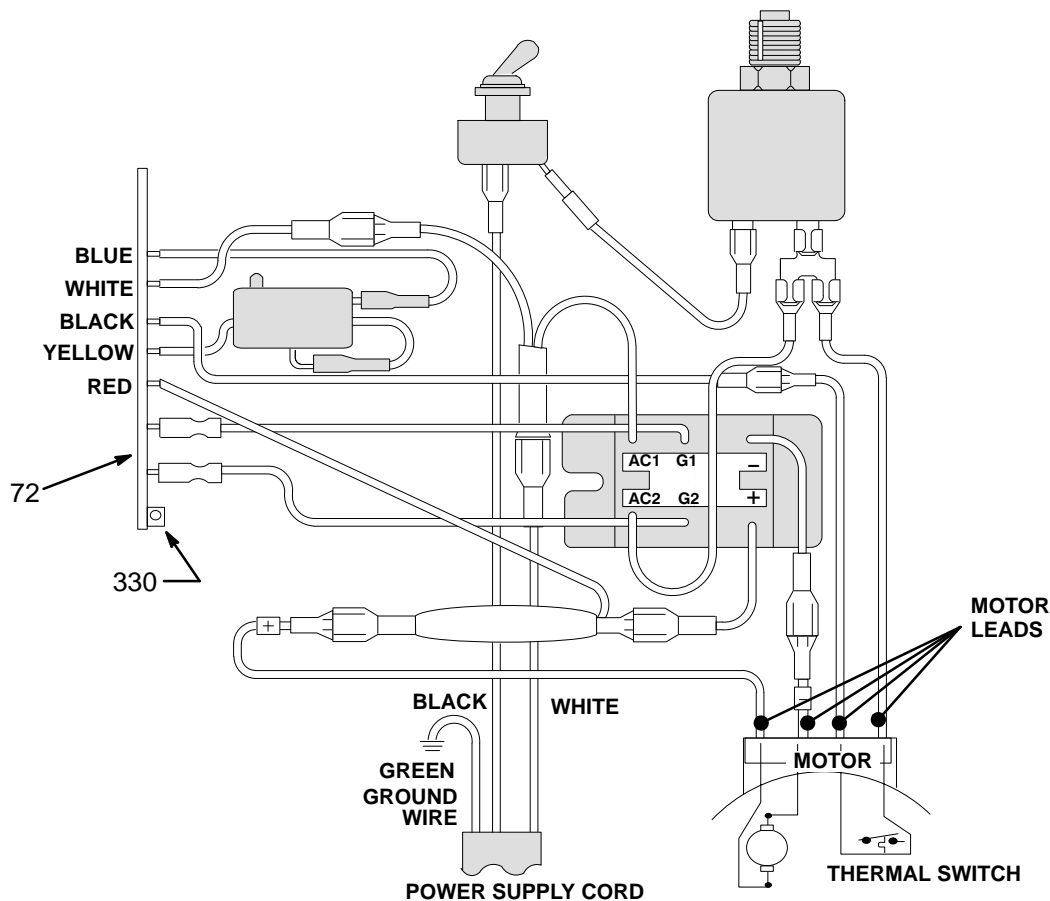

Fig 28-2

PRESSURE CONTROL REPLACEMENT

WARNING

To reduce the risk of serious injury, follow the illustrated **Pressure Relief Procedure** warning on page 24 whenever you are instructed to relieve pressure.

NOTE: Read the GENERAL REPAIR INFORMATION on page 24 before doing this procedure.

NOTE: Refer to Fig 29-1 for this procedure.

1. Relieve pressure.
2. Disconnect the fluid outlet hoses. Disconnect the hose (68) between the pump and pressure control.
3. Loosen the filter bracket nut (37).
4. Hold the hex of the pressure control adapter (341) firmly with a 3/4" open end wrench. Use an adjustable wrench to unscrew the swivel union (38 or 5), and then remove the fluid filter (67).
5. Remove the pressure control cover (62). Disconnect the four motor leads. See Fig 28-2.
6. Remove the circuit board and retain it. See page 28.
7. Remove the conduit (1).
8. Remove the three pressure control mounting screws (7), lockwashers (9) and nuts (10). Remove the pressure control.
9. Remove the screws (20) and back mounting bracket (64).

CAUTION

Do not allow the adapter (341) to turn while installing the new pressure control assembly. Turning it can damage the sensitive bourdon tube. Hold the adapter firmly with a 3/4" open end wrench while screwing in the swivel union (38 or 5).

10. Install the new pressure control assembly in the reverse order of disassembly. Reinstall the conduit seal (26) around the wires in the conduit connector (345) to prevent motor contamination from entering the control. See the DETAIL below.
11. Perform the **PRESSURE CONTROL ADJUSTMENT**, page 30, before regular operation of the sprayer.

UPRIGHT CART

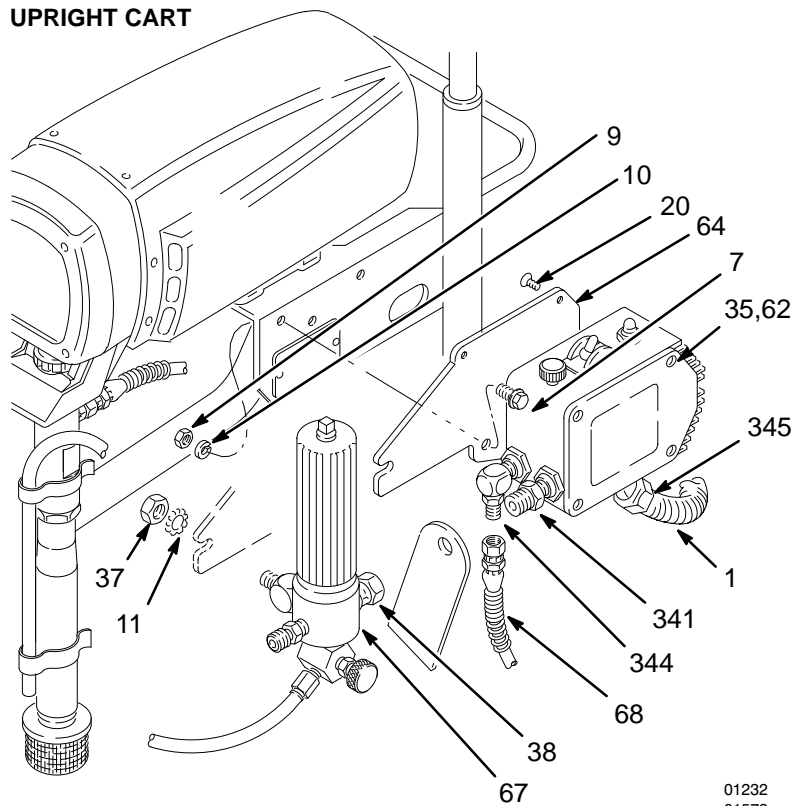

01232
01578

CAUTION
Do not allow the adapter (341) to turn at any time.

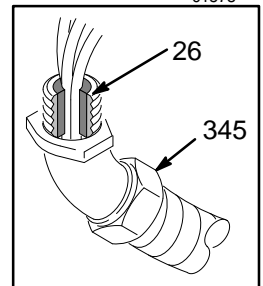

LO-BOY CART

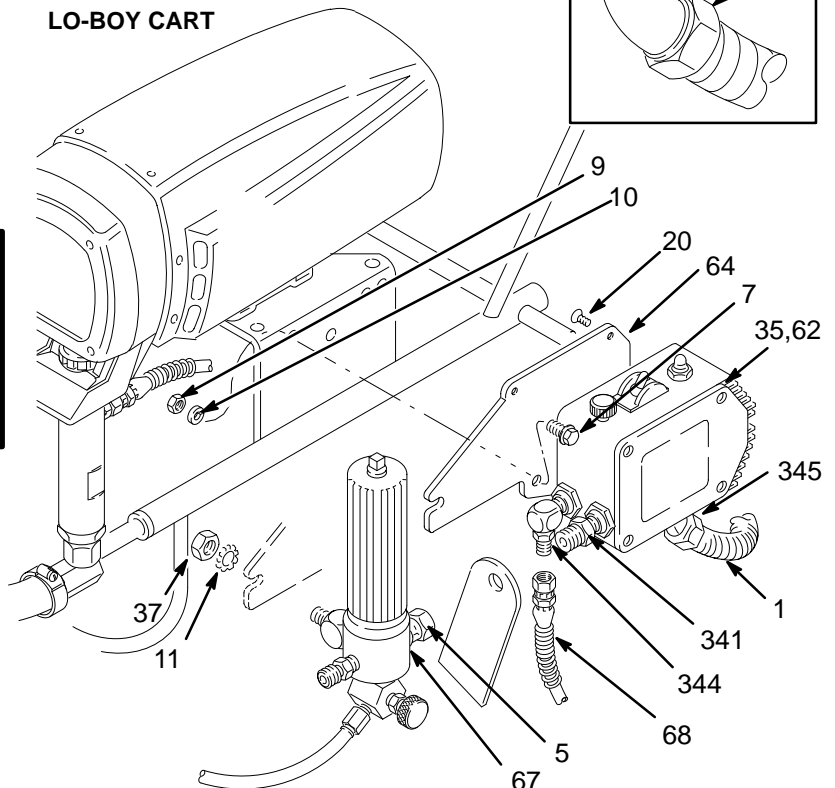

Fig 29-1

01588

PRESSURE CONTROL ADJUSTMENT

WARNING

USE EXTREME CAUTION WHEN PERFORMING THIS ADJUSTMENT PROCEDURE to reduce the risk of a fluid injection injury or other serious bodily injury which can result from component rupture, electric shock, fire, explosion, or moving parts.

This procedure sets the sprayer to 2750 psi (195 bar) **MAXIMUM WORKING PRESSURE** and sets the overpressurization switch (microswitch) to approximately 3600 psi (242 bar).

Perform this procedure whenever the pressure control assembly is removed and reinstalled or replaced, or a new circuit board is installed.

Improper adjustment can cause the sprayer to overpressurize and result in component rupture, fire or explosion. It may also prevent the sprayer from obtaining the maximum working pressure, resulting in poor sprayer performance.

NEVER try to increase the sprayer's maximum working pressure of 2750 psi (195 bar) by performing these adjustments in any other way. Normal operation of the sprayer at higher pressures may result in component rupture, fire or explosion. To perform this adjustment, however, the sprayer pressure must be *temporarily* increased above the normal working pressure.

Use a *new* 50 ft (15.2 m) spray hose rated for at least 2750 psi (195 bar) **MAXIMUM WORKING PRESSURE**. A used, under-rated hose could develop a high pressure leak or rupture.

WARNING

To reduce the risk of serious injury, follow the illustrated **Pressure Relief Procedure** warning on page 24 whenever you are instructed to relieve pressure.

NOTE: Read the **GENERAL REPAIR INFORMATION** on page 24 before doing this procedure.

Required tools for adjustment procedure

3/8 in. nut driver or 3/8 in. socket wrench

1/4 in. open end wrench

7/16 in. open end wrench

0 – 5000 psi, oil-filled test gauge, Part No. 102–814

Pail of clean water

Mineral spirits

NEW 3000 psi (210 bar) high pressure spray hose, Part No. 223–541

1. Relieve pressure.
2. See the above list of tools and equipment needed. Remove the plug (A) from the top of the fluid filter and install the fluid-filled pressure gauge. See Fig 30–1. Connect the gun to the **new** test hose and connect the hose to the sprayer outlet.

3. Remove the pressure control cover (62).
4. Place the pump suction tube in a pail of clean water.
5. Be sure the gun safety latch is engaged.

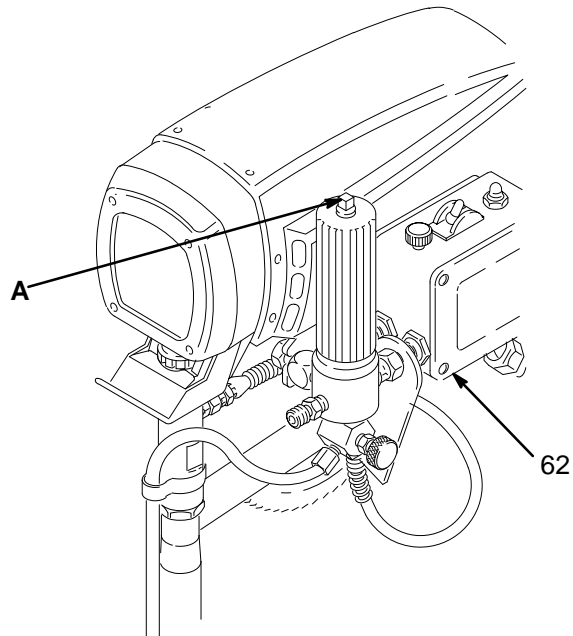

Fig 30–1

01566

PRESSURE CONTROL ADJUSTMENT

6. Plug in the sprayer.
7. Turn the pressure control knob (B) to the *minimum* setting (fully counterclockwise), and turn the sprayer ON. **THE DISPLACEMENT PUMP SHOULD NOT CYCLE**

If it does cycle, remove the plug (15) from the bottom of the pressure control. Insert a 3/8 in. nut driver through the opening, and unscrew the pressure adjustment nut (T) just until the sprayer stops running.

Adjust the Overpressurization Switch

8. With the spray gun triggered, **slowly** turn the pressure control knob clockwise just until the sprayer starts. Prime the pump and hose.
9. Slowly turn the pressure control knob to the maximum setting. While watching the red light on the circuit board and the pressure gauge, turn the nut (T) **slowly** to increase pressure until the red light goes out **and** the gauge reads between 3400 – 3800 psi (238 – 266 bar).

If the red light does not go out by 3800 psi (266 bar), loosen the nut (P) and adjust the stud (Q) until the light goes out.

If the red light goes out before 3400 psi (238 bar), loosen the nut (P) and adjust the stud (Q) until the light goes out between 3400 – 3800 psi (238 – 266 bar).

10. Tighten the nut (P) if it was loosened in Step 9.
11. Trigger the gun to relieve pressure. Release the trigger and engage the safety latch. Repeat Step 9 to verify your results.

12. Install the pressure control cover.

Maximum Working Pressure Adjustment

13. Turn the sprayer OFF. Disengage the gun safety latch. Trigger the gun into a grounded waste container until pressure is relieved. Engage the gun safety latch.
14. Use the 3/8 in. nut driver to turn the pressure adjustment nut (T) counterclockwise one full turn.
15. With the pressure control knob at the *minimum* setting, turn the sprayer ON.
16. **Slowly** turn the pressure control knob (B) clockwise to the maximum setting and hold it there. Use a 3/8 in. nut driver or socket wrench to slowly turn the pressure adjustment nut (T) clockwise until the gauge reads EXACTLY 2750 psi (195 bar).
17. Turn the pressure control knob to the minimum setting. Release the gun safety latch and trigger the gun into a grounded waste container until pressure is relieved. Engage the gun safety latch. Slowly increase the pressure to verify that the maximum working pressure is set at 2750 psi (195 bar).

CAUTION

To prevent pump corrosion, flush the water out of the pump, hose and gun with mineral spirits. Be sure to close the drain valve, first. Use the lowest pressure necessary to flush. Relieve pressure. Leave the mineral spirits in the pump to protect it until you are ready to spray again.

18. Install the plug (15) in the bottom of the pressure control. Remove the gauge assembly and reinstall the plug. Flush out the water with mineral spirits.

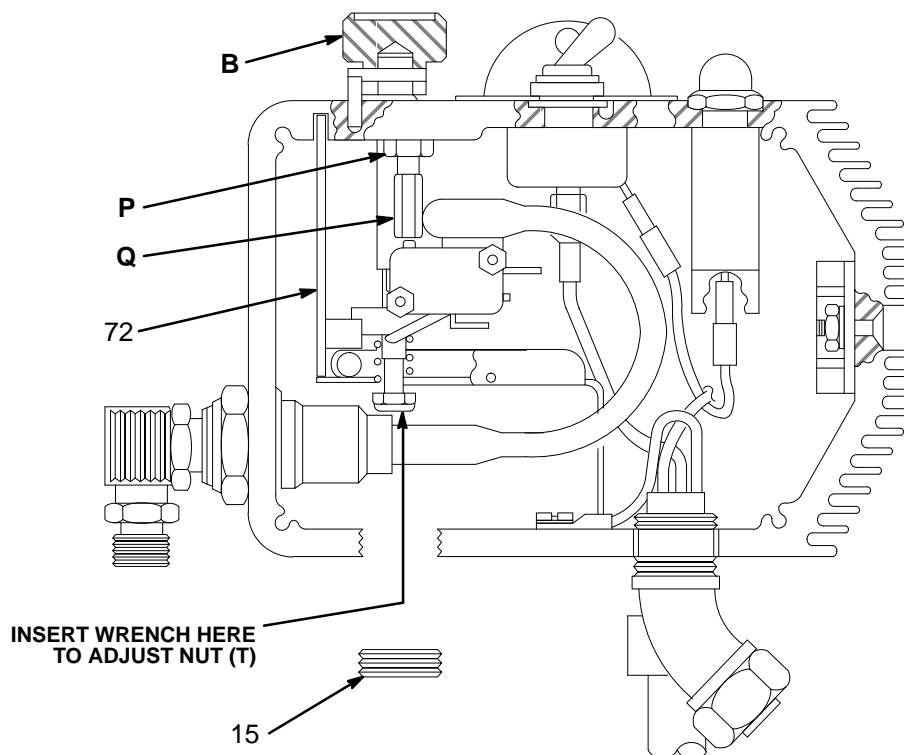

Fig 31-1

01243

DRIVE HOUSING, CONNECTING ROD & CRANKSHAFT REPLACEMENT

WARNING

To reduce the risk of serious injury, follow the illustrated **Pressure Relief Procedure** warning on page 24 whenever you are instructed to relieve pressure.

NOTE: Read the GENERAL REPAIR INFORMATION on page 24 before doing this procedure.

NOTE: Stop the sprayer at the bottom of its stroke to get the crankshaft (69) in its lowest position. To lower the crankshaft manually, carefully rotate the blades of the motor fan with a screwdriver.

NOTE: Refer to Fig 26 unless otherwise noted.

1. Remove the front cover.
2. Hold a wrench on the pump intake valve and unscrew the suction tube.
3. Disconnect the hose (68) from the pump.
4. Use a screwdriver to push up the retaining spring (42). Push the pin (43) out the rear. See Fig 32-1.

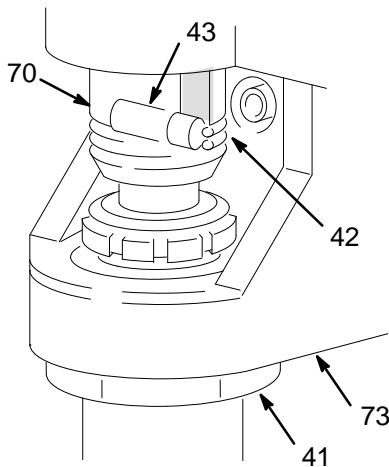

Fig 32-1

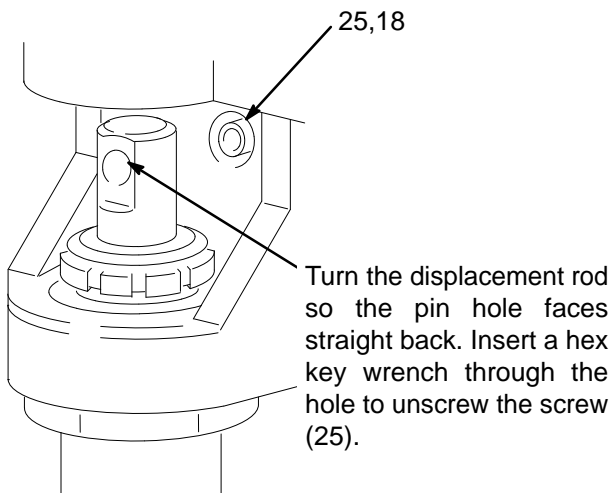

Fig 32-1

01579

5. Loosen the jam nut (41) with an adjustable wrench. Unscrew and remove the pump.
6. See Fig 32-1 to remove one of the screws (25) which is hidden. Remove the other two screws (25) from the recess of the drive housing. See Fig 26.
7. Remove the motor shield (58).
8. Remove the two screws (14) holding the motor (75) to the drive housing (73).
9. Lightly tap the lower rear of the drive housing (73) with a plastic mallet to loosen it from the front of the motor. Then pull the drive housing straight off.

CAUTION

Do not allow the gear (71) to fall. It may stay attached to the drive housing or to the motor.

Do not lose the thrust balls (8) located at each end of the gear (71). The balls are heavily covered with grease and usually stay in the shaft recesses, but they could be dislodged. If caught between the gears and not removed, the balls will damage the drive housing. If the balls are not in place, the bearings will wear prematurely.

10. Inspect the drive housing (73) for excessive wear and replace parts as needed.
11. Pull the crankshaft (69) out. Inspect it for wear or damage and replace it, if necessary. Be sure the thrust bearings (69a and 69b) are in the proper place on crankshaft.
12. Remove the connecting rod (70). Inspect it for wear or damage. Replace the rod, if necessary.
13. Evenly lubricate the inside of the bronze bearing in the drive housing with high quality motor oil. Liberally pack the roller bearing and gears with bearing grease.
14. Carefully align the drive housing and front of the motor with the locating pins. Push the drive housing onto the motor, or tap it into place with a plastic mallet.

CAUTION

DO NOT use the drive housing screws (25) to try to align or seat the housing to the motor; doing so will not ensure proper alignment, but will cause premature bearing wear.

15. Install the screws (14 and 25) and lockwashers (18) on the drive housing and tighten evenly.
16. Reinstall the motor shield (58).

DRIVE HOUSING, CONNECTING ROD & CRANKSHAFT REPLACEMENT

14. Screw the displacement pump about 3/4 of the way into the drive housing (73). Hold the pin (43) up to the pin hole in the connecting rod assembly (70) and continue screwing in the pump until the pin slides easily into the hole. Back off the pump until the top threads of the pump cylinder are flush with the face of the drive housing and the outlet nipple (39) is facing back. Push the retaining spring (42) into the groove all the way around the connecting rod. Tighten the locknut (41) very tight – about 70 ft-lb (95 N.m) – with a 1-3/4 in. open end wrench and a light hammer. See Fig 33-1 and 33-2.

WARNING

Be sure the retaining spring (42) is firmly in the groove all the way around, to prevent the pin (43) from working loose due to vibration. See Fig 33-1.

If the pin works loose, it or other parts could break off due to the force of the pump action. These parts could be projected through the air and result in serious bodily injury or property damage, including damage to the pump connecting rod or bearing housing.

15. Reinstall the remaining parts.

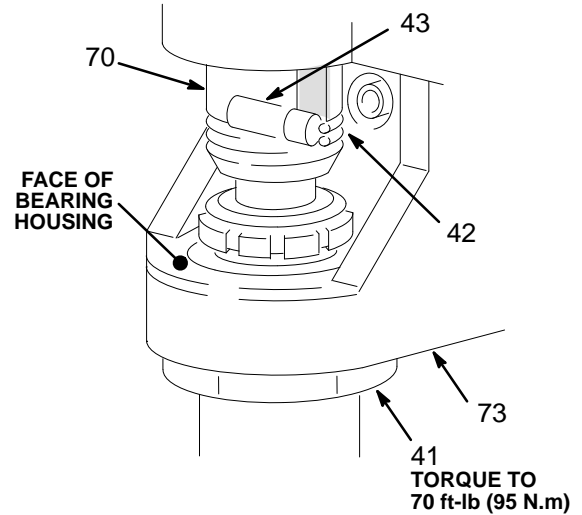

Fig 33-1

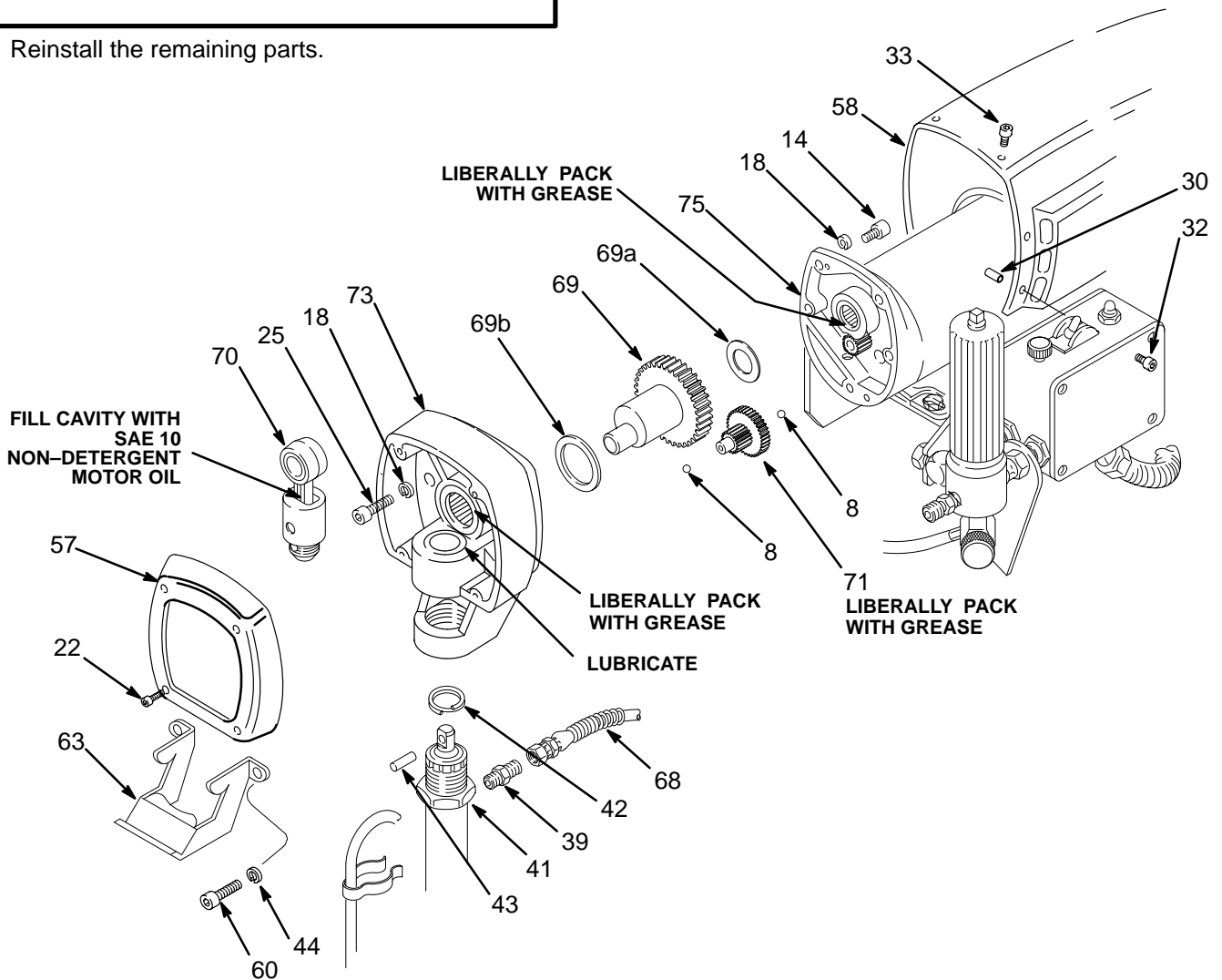

Fig 33-2

MOTOR REPLACEMENT

WARNING

To reduce the risk of serious injury, follow the illustrated **Pressure Relief Procedure** warning on page 24 whenever you are instructed to relieve pressure.

NOTE: Read the GENERAL REPAIR INFORMATION on page 24 before doing this procedure.

NOTE: See Fig 35–1 except where noted.

1. Remove the pressure control cover. Disconnect the four motor leads. See the **WIRING DIAGRAM** in Fig 35–1. Remove the conduit seal (26) from the conduit elbow (345) coming into the control.
2. Use an adjustable wrench to loosen the conduit connector nut (345) at the pressure control (77).
3. Swing the conduit (1) away from the pressure control.
4. Pull the motor leads through the connector, one at a time.

CAUTION

Always pull the motor leads one at a time to avoid loosening the terminals.

5. Loosen the nut of the connector (29) at the motor and pull the conduit (1) away from the motor, then pull the leads through the conduit, one at a time.
6. Unscrew the connector (29) from the motor.
7. Pull the motor leads through the connector, one at a time.
8. Remove the front cover (57).
9. Unscrew the suction tube from the pump, holding a wrench on the pump intake valve to keep the pump from loosening.
10. Disconnect the hose (68) from the pump.
11. Use a screwdriver to push up the retaining spring (42). Push the pin (43) out the rear. See Fig 25.
12. Loosen the jam nut (41) with an adjustable wrench. Unscrew the displacement pump.

13. Turn the displacement rod so the pin hole faces straight back. Insert a hex key wrench through the hole to unscrew the screw (25). See Fig 32–1. Remove the other two screws from the recess of the drive housing.
14. Remove the motor shield (58).
15. Remove the two screws (14) from the top of the motor.
16. Use a plastic mallet to gently tap the displacement pump (74) from the rear to loosen the drive housing from the front of the motor. Then pull the drive housing away from the motor.

CAUTION

DO NOT allow the gear cluster (71) to fall when removing the drive housing (73). It is easily damaged if dropped.

DO NOT lose the thrust balls (8) located at each end of the gear cluster (71). The balls are heavily covered with grease and usually stay in the gear recesses, but they could be dislodged. If caught between gears and not removed, the balls will damage the drive housing. If the balls are not in place, the bearings will wear prematurely.

17. Remove the four motor mounting screws (7) and related hardware.
18. Lift the motor (75) off the frame.
19. Align the new motor with the frame mounting holes. Install the screws (7) and related hardware.
20. Liberally grease the gear cluster (71) and pinion gear (A) and pack all bearings in the motor front end bell. Check to be sure the thrust balls (8) are in place.
21. Place the bronze-colored washer (69a) and THEN the silver-colored washer (69b) on the crankshaft (69).
22. Align the gears and push the drive housing (73) straight onto the front of the motor and the locating pins.
23. Starting at Step 17 and working backwards, continue to reassemble the sprayer.

NOTE: Use a turning motion on the conduit (1) when feeding wires through it.

MOTOR REPLACEMENT

WIRING DIAGRAM

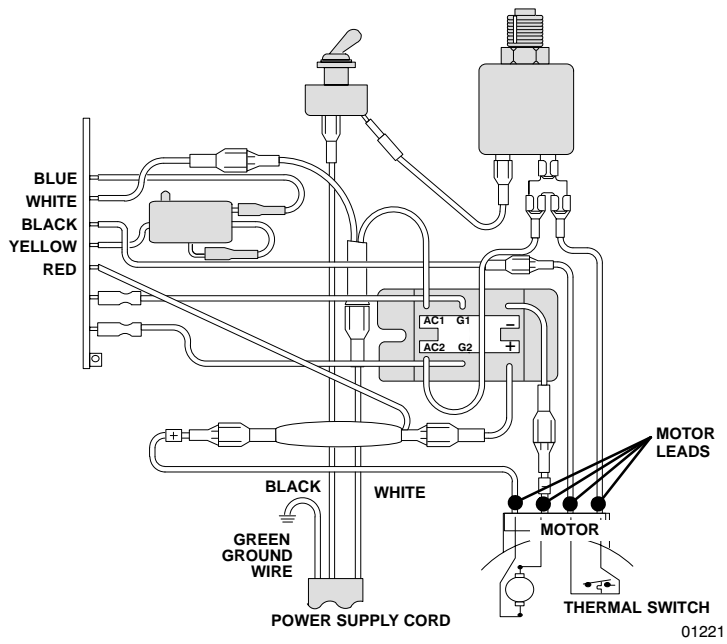

DETAIL

Shows position of conduit seal (26) in conduit connector (345)

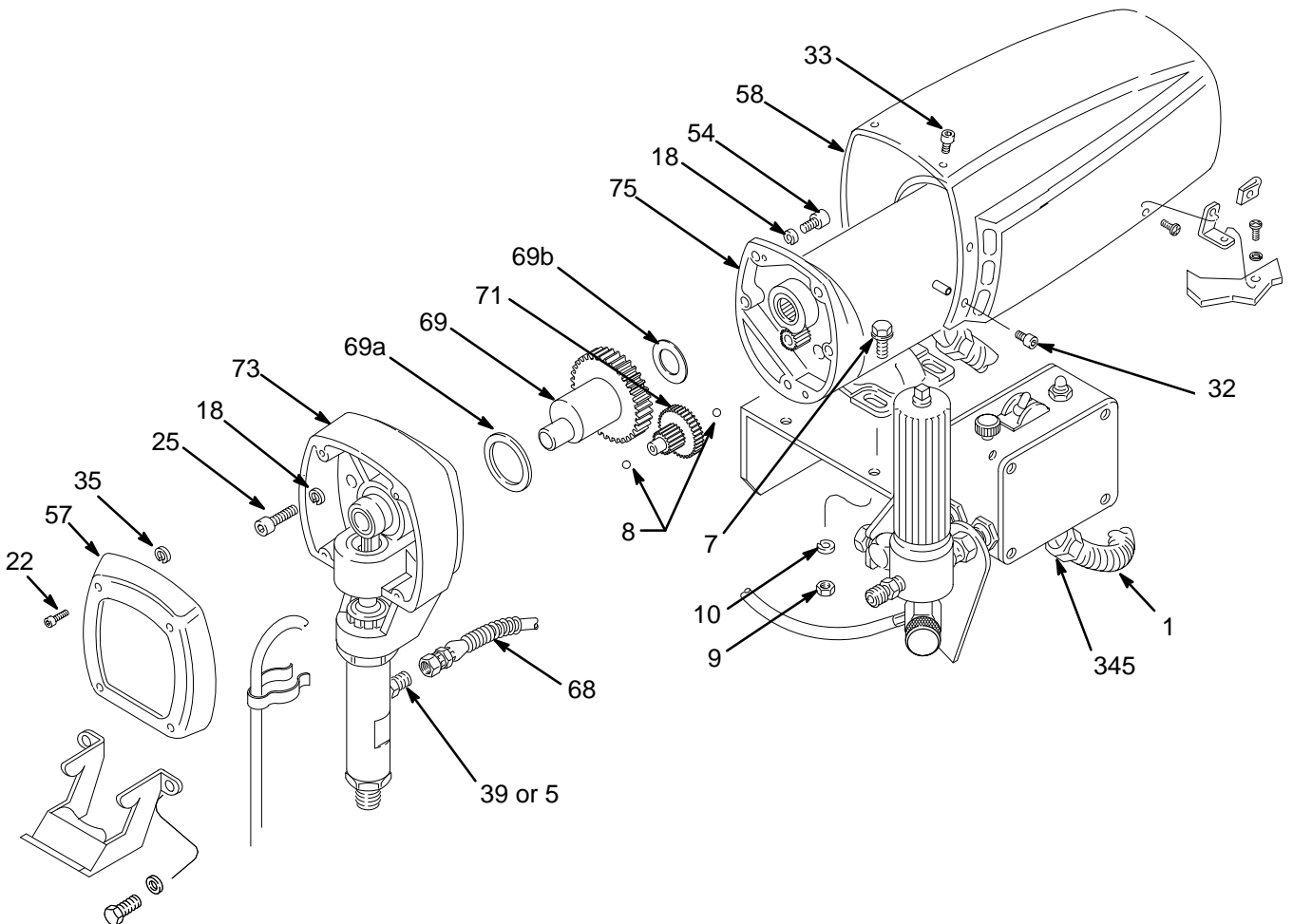
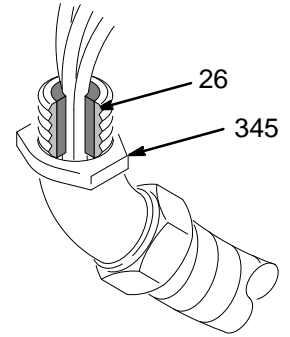

Fig 35-1

01581

DISPLACEMENT PUMP REPAIR

WARNING

To reduce the risk of serious injury, follow the **Pressure Relief Procedure** warning on page 24 whenever you are instructed to relieve pressure.

NOTE: Read the GENERAL REPAIR INFORMATION on page 24 before doing this procedure.

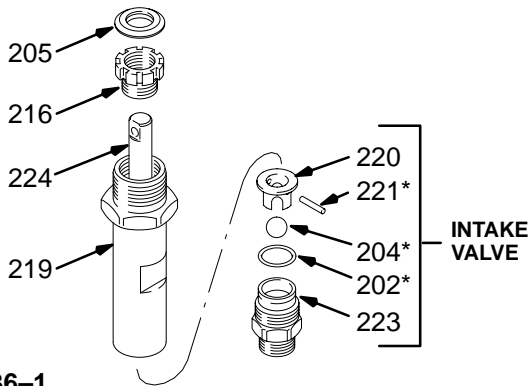

Fig 36-1

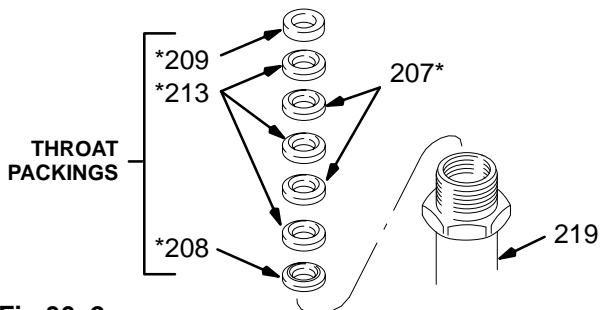

Fig 36-2

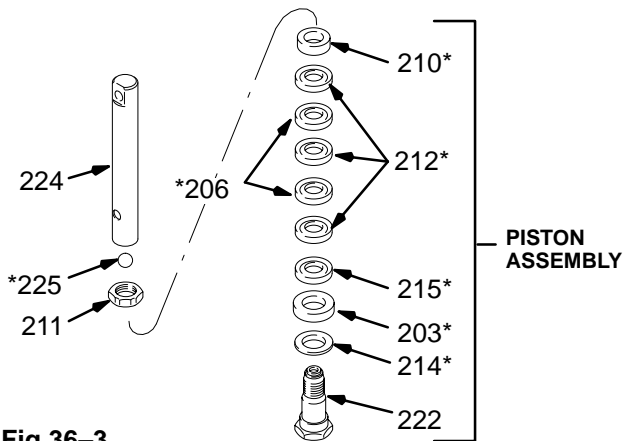

Fig 36-3

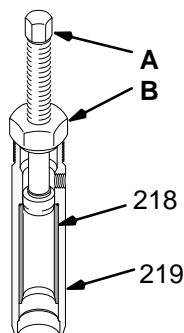

Fig 36-4

0028

NOTE: Use Packing Repair Kit 222-587. An asterisk following a reference number, i.e., (210*), indicate that the part included in the kit. For the best results, use all the new parts in the kit even if the old ones still look good.

NOTE: Clean and inspect parts after disassembling the pump. Replace worn or damaged parts.

Disassembling the Pump

1. See page 38 to remove the pump.
2. Unscrew the intake valve (223) from the cylinder (219). Remove all parts. See Fig 36-1.
3. If no further service is needed, reassemble the intake valve. Be sure you use a new gasket (202*).
4. Remove the packing nut (216) and plug (205). See Fig 36-1.
5. Use a plastic mallet to tap the piston rod (224) down, then pull the rod out through the bottom of the cylinder (219). See Fig 36-1.
6. Remove the throat packings and glands. See Fig 36-2.
7. Clamp the flats of the piston rod in a vise. Loosen the retaining nut (211). Unscrew the piston valve (222) from the rod. Remove all parts from the piston valve (222). See Fig 36-3.
8. Remove and clean the sleeve (218). Use ONLY the special sleeve removal tool, P/N 222-586.

WARNING

Always use the special sleeve removal tool to remove the sleeve. Other removal methods could cause the pump to rupture, resulting in serious bodily injury. If the sleeve cannot be removed easily using the tool, return the sleeve and cylinder to your Graco distributor for removal.

9. Screw the large nut (B) of the tool into the top of the cylinder (219). Screw down the rod (A) to push the sleeve out. Remove the tool. See Fig 36-4.

Reassembling the Pump

NOTE: Alternate leather and plastic packings as shown in Fig 37-1. The lips of the throat "V" packings must face down. The lips of the piston "V" packings must face up. The lips of the U-cup seal (203*) face down. Incorrect installation damages the packings and results in pump leaking.

NOTE: Soak leather packings in oil before using them.

1. Check the outside of the piston rod (224) and the inside of the sleeve (218) for scoring or scratches. If these parts are damaged, new packings will not seal properly. Replace these parts if needed.
2. Stack the backup washer (214), seal (203*), female gland (215*), alternate packings (212*,206*), and then male gland (210*) onto the piston valve (222). See Fig 36-3.

DISPLACEMENT PUMP REPAIR

- Tighten the packing retaining nut (211) against the piston valve (222) to 19 ft-lb (27 N.m).

Note the alignment of the piston (222) to the packing retainer nut (211). Maintain this alignment through Steps 5, 6 and 7.

- Place the ball (225) on the piston valve (222). See Fig 37-1.

CAUTION

Step 5 is critical. Follow the procedure carefully to avoid damaging the packings by overtightening.

- Apply one drop of adhesive, supplied, to the piston valve threads. Then hand tighten the valve assembly into the piston rod just until the nut (211) contacts the rod. See Fig 37-1.

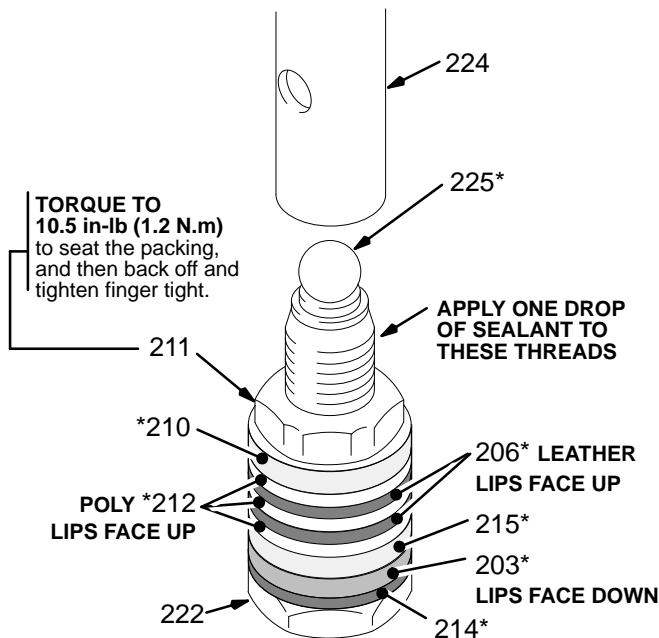

Fig 37-1

- Place the flats at the top of the rod in a vise.
- Use a wrench to **CAREFULLY** tighten the nut (211) onto the piston rod to 19 ft-lbs (25 N.m). See Fig 37-2.

Use two wrenches to maintain the alignment mentioned in Step 7, above.

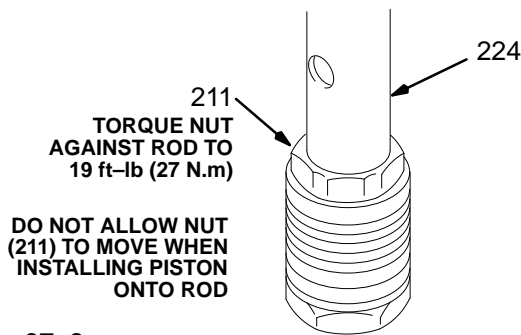

Fig 37-2

- Stack the male gland (208*), alternate packings (213*,207*), and female gland (209*) into the top of the cylinder (219). See Fig 37-3.

- Install the packing nut (216) and plug (205), but leave loose for now. See Fig 37-3.

- Coat the piston rod and packings with oil. Carefully slide the assembly **INTO THE TOP OF THE SLEEVE**.

NOTE: The tapered end of the sleeve is the bottom of it. See Fig 38-1.

- Place a new o-ring (217*) firmly in the cylinder groove. See Fig 37-3.

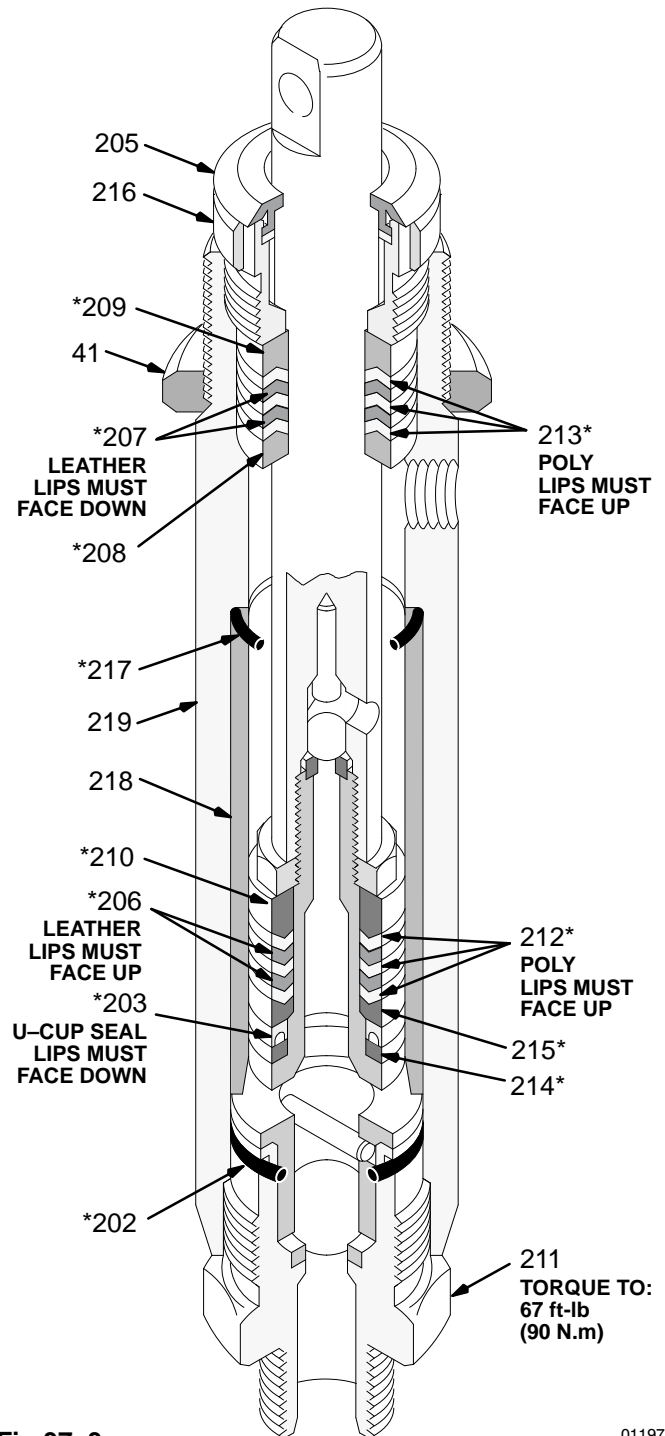

Fig 37-3

DISPLACEMENT PUMP REPAIR

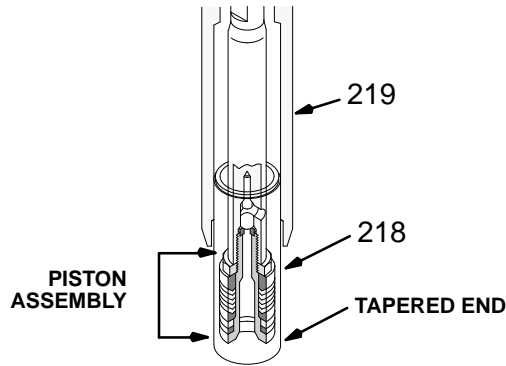

Fig 38-1

0030

12. Slide the sleeve/piston rod assembly **INTO THE BOTTOM OF THE CYLINDER**. This is to prevent packing damage during reassembly. See Fig 38-1.
13. Screw down the cylinder locknut (41) until it is finger tight at the bottom of the external cylinder threads.
14. Place the flats of the intake valve (223) in a vise. Install a new o-ring (202*). Screw the pump cylinder into the valve. Torque to 67 ft-lb (90 N.m). See Fig 37-3.
15. Install the pump.

REMOVING AND INSTALLING A PUMP

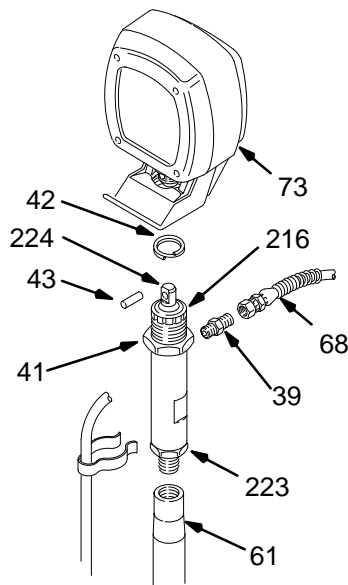

Fig 38-2

01582

3. Push the retaining spring (42) into the groove all the way around the connecting rod.
4. Tighten the locknut (41) very tight—about 70 ft-lb (97 N.m)—with a 2 in. open-end wrench and a light hammer.

WARNING

Be sure the retaining spring (42) is firmly in the groove of the connecting rod, all the way around, to prevent it from working loose due to vibration. Refer to Fig 38-3.

If the pin works loose, parts could break off due to the force of the pumping action. These parts could be projected through the air and result in serious bodily injury, sprayer damage or property damage.

CAUTION

If the locknut (41) loosens during operation, the threads of the bearing housing (73) will be damaged. Be sure to tighten the locknut firmly.

5. Tighten the packing nut (216) just enough to stop leakage, but no tighter. Fill the wet-cup/packing nut 1/3 full with Graco TSL. See Fig 38-2.

Remove the pump See Fig 38-2.

1. Flush the pump. Relieve pressure. Stop the pump with the piston rod (224) in its lowest position or carefully rotate the blades of the fan with a screwdriver to lower the rod.
2. While holding the pump intake valve (223) steady with a wrench, unscrew the suction tube (61).
3. Disconnect the hose (68).
4. Push the retaining spring (42) up. Push out the pin (43).
5. Loosen the locknut (41) and unscrew the pump from the bearing housing (73).

Install the pump See Fig 38-3.

1. Screw the displacement pump 3/4 of the way into the bearing housing (73).
2. Hold the pin (43) up to the pin hole in the connecting rod assembly (70) and continue screwing in the pump until the pin slides easily into the hole. Back off the pump until the top threads of the pump cylinder are flush with the face of the bearing housing and the outlet nipple (39) is straight back.

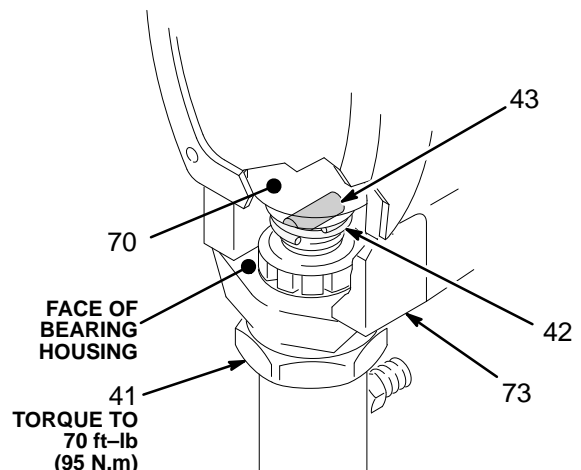

Fig 38-3

0031

PARTS DRAWING & LIST – DISPLACEMENT PUMP

Model 222–584, Series A Sleeved Displacement Pump

Includes items 202 to 225

REF NO.	PART NO.	DESCRIPTION	QTY
202	108–954*	PACKING, o-ring, PTFE ®	2
203	105–522*	SEAL, u-cup, polyurethane	1
204	105–445*	BALL, sst	1
205	180–656	PLUG	1
206	176–749*	V-PACKING, leather	2
207	176–755*	V-PACKING, leather	2
208	176–754*	GLAND, male	1
209	176–757*	GLAND, female	1
210	176–750*	GLAND, male	1
211	176–751	NUT, hex, retaining	1
212	176–882*	V-PACKING, plastic	3
213	176–997*	V-PACKING, plastic	3
214	180–161*	WASHER, backup	1
215	180–073*	GLAND, female	1
216	176–758	NUT, packing	1
218	183–571	SLEEVE, cylinder	1
219	183–562	CYLINDER	1
220	183–559	GUIDE, ball	1
221	183–555*	PIN, ball stop	1
222	218–197	VALVE, piston	1
223	221–098	VALVE, intake	1
224	183–563	ROD, piston	1
225	105–444*	BALL	1

***Supplied in repair kit 222–587.**
Keep a repair kit on hand to reduce down time.

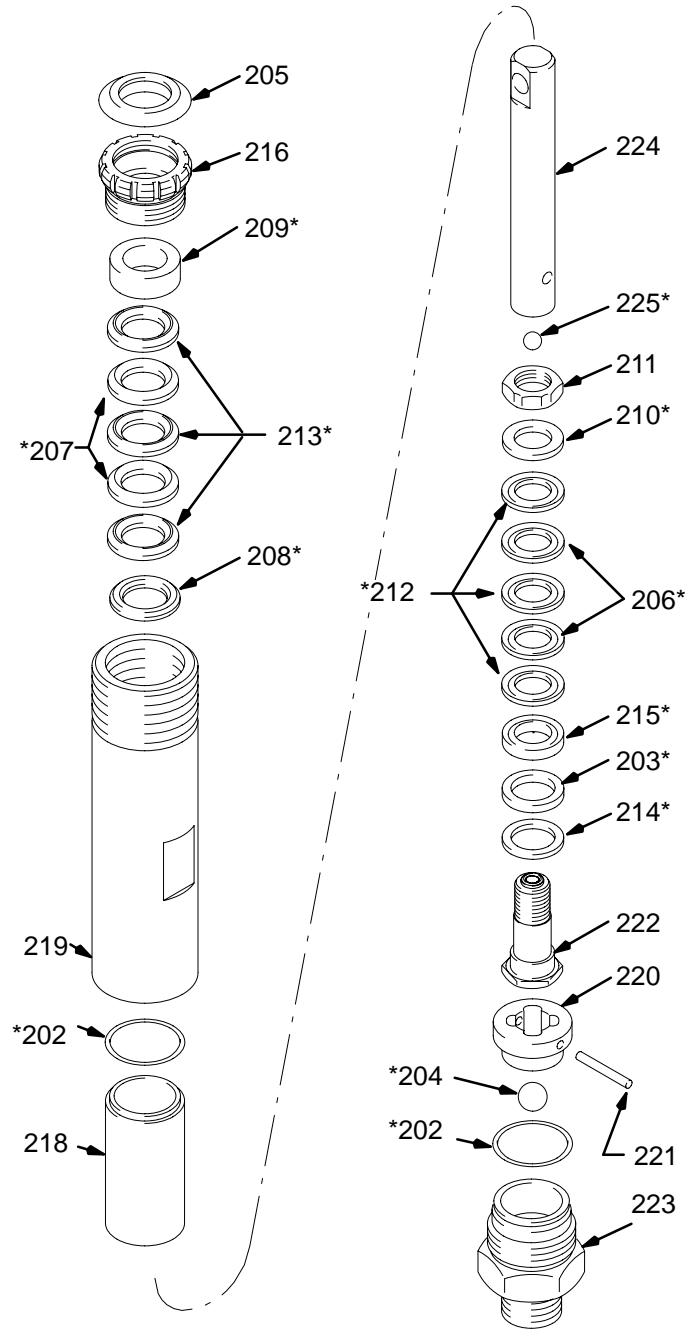

ACCESSORIES

Must be purchased separately.

NOTE: Be sure you order the correct tool for your pump.

222–585 Sleeve Removal Tool, for pump 222–584.

PARTS – COMPLETE SPRAYER

Model 231-032, Series C
 Basic Sprayer with Upright Cart
 Includes items 1 to 98

Model 231-041, Series B
 Complete Sprayer with Upright Cart
 Includes items 1 to 102

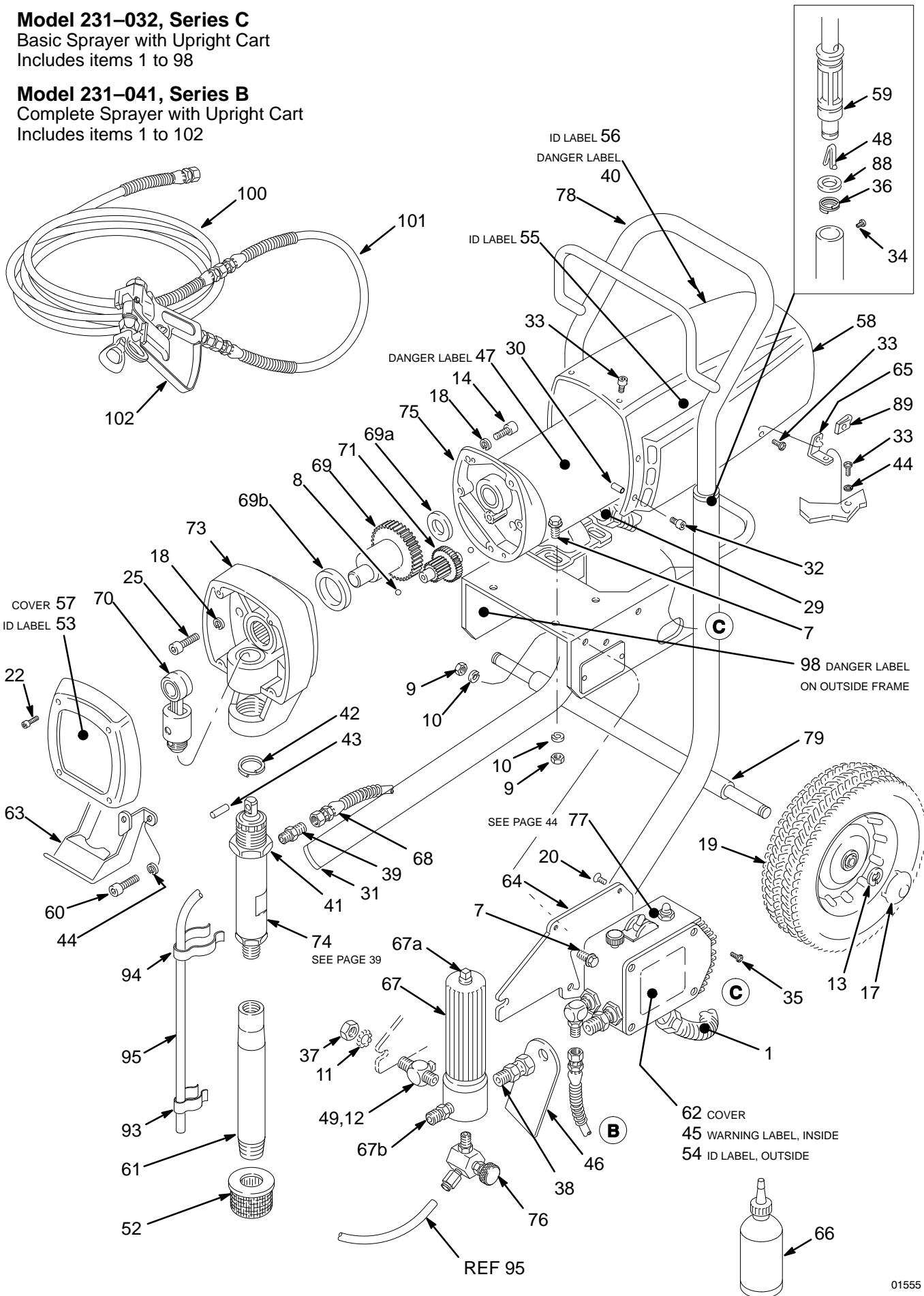

PARTS DRAWING – UPRIGHT SPRAYER

Model 231–032, Series C

Includes items 1 to 98

REF NO.	PART NO.	DESCRIPTION	QTY
1	065–099	CONDUIT, specify length when ordering	0.8 ft
7	110–963	SCREW, serrated flange, hex hd, 5/16–18 x 3/4"	7
8	100–069	BALL, stainless steel, 1/4" dia.	2
9	100–188	NUT, heavy hex, 5/16–18 unc–2a	7
10	100–214	LOCKWASHER, spring, 5/16"	7
11	100–322	LOCKWASHER, ext. shakeproof, 7/16"	1
12	100–509	PLUG, square head, 1/4 npt(m)	1
13	101–242	RING, retaining	2
14	101–682	SCREW, socket head, 1/4–20 x 0.62 "	2
15	101–754	PLUG, soc hd, 3/8 npt	1
17	104–811	HUBCAP	2
18	105–510	LOCKWASHER, spring, 1/4"	5
19	106–062	WHEEL, semi–pneumatic	2
20	106–078	SCREW, ovhd, thd frmg, no 6–24 x 1/2", type "C"	4
21	107–194	WASHER, flat	4
22	107–209	SCREW, filh, no. 8–32 x 1"	4
23	107–258	TIP, grip <i>see page 44</i>	1
25	107–445	CAPSCREW, sch, 1/4–20 unrc–3a x 1.5"	3
26	107–447	SEAL, conduit <i>see page 44</i>	2
29	108–460	CONNECTOR, conduit, 45°	1
30	108–663	SPACER	2
31	108–691	PLUG, tubing, frame	2
32	108–709	SCREW, pnhd, 8–32 x 1"	2
33	108–865	SCREW, pnhd, No. 8 x 3/8"	8
34	109–032	SCREW, pnhd, 10–24 x 1/4"	4
35	110–037	SCREW, pnhd, 10–24 x .625"	4
36	110–243	RING, retaining	2
37	150–513	NUT, jam, 7/16"	1
38	155–665	UNION, adapter, 3/8" npsm swivel x 3/8 npt(m)	1
39	162–453	NIPPLE, hex, 1/4 npsm x 1/4 npt	1
40	185–952*	LABEL, DANGER, English	1
41	176–762	NUT, hex, 1–1/2–18	1
42	176–817	SPRING, retaining	1
43	176–818	PIN, straight, hdls, 3/8" dia. x 1"	1
44	100–020	LOCKWASHER, 3/16"	4
45	177–762*	LABEL, WARNING	1
46	178–034	TAG, WARNING	1
47	185–954*	LABEL, DANGER, English	1
48	111–590	BUTTON, snap	2
49	179–945	ADAPTER, elbow, special, 1/4–18 npt (m x f)	1
50	180–041	PIN, straight <i>see page 44</i>	1
52	187–190	STRAINER	1
53	181–607	LABEL, identification	1
54	181–608	LABEL, identification	1
55	181–609	LABEL, identification	1
56	181–610	LABEL, identification	1
57	181–611	COVER, housing	1
58	223–096	SHIELD, MOTOR, <i>includes items 30,32,33,46, 55,56</i>	1

Model 231–041, Series B

Includes items 1 to 102

REF NO.	PART NO.	DESCRIPTION	QTY
59	187–603	SLEEVE	2
60	103–846	CAPSCREW, soc hd	2
61	185–417	TUBE, suction	1
62	183–995	COVER, pressure control	1
63	185–365	HANGER, pail	1
64	183–365	BRACKET, mounting	1
65	185–384	BRACKET, support, shield	1
66	206–994	THROAT SEAL LIQUID, 8 oz. (0.27 liter)	1
67	214–570	FLUID FILTER <i>Includes items 67a and 67b see manual 307–273 for additional parts</i>	1
67a	100–040	.PLUG	1
67b	162–453	.NIPPLE, hex, 1/4 npsm x 1/4 npt	1
68	223–766	HOSE, grounded, nylon, 1/4" ID, 29" (736 m) long, spring guard both ends	1
69	218–242	CRANKSHAFT ASSEMBLY, <i>includes items 69a and 69b</i>	1
69a	180–131	.BEARING	1
69b	107–434	.BEARING	1
70	218–359	CONNECTING ROD	1
71	218–364	GEAR REDUCER	1
72	218–405	CIRCUIT BOARD <i>see page 44</i>	1
73	223–100	DRIVE HOUSING <i>Includes item 73a</i>	1
73a	110–293	.GREASE <i>not shown</i>	1
74	222–584	DISPLACEMENT PUMP <i>see page 39 for parts</i>	1
75	222–678**	MOTOR, electric, 1/2 hp <i>includes items 75a to 75c, and one each of items 8 and 40</i>	1
75a	107–267	.TERMINAL, 0.187, 16–14 AWG	2
75b	107–504	.TERMINAL, 0.187, 22–18 AWG	1
75c	103–885	.TERMINAL, 0.250, 16–14 AWG	1
76	222–198	PRESSURE DRAIN VALVE	1
77	220–455	PRESSURE CONTROL <i>see parts list on page 44</i>	1
78	222–554	HANDLE, cart	1
79	222–555	CART	1
88	183–350	WASHER	2
89	110–240	SPEED NUT	2
93	186–245	CLIP, spring	1
94	178–341	CLIP, spring	1
95	186–495	DRAIN TUBE	1
98	185–955*	LABEL, DANGER, French	1
100	223–541	HOSE, grounded, nylon, 1/4" ID, 50 ft (15 m) long, spring guard both ends	1
101	214–701	HOSE, grounded, nylon, 3/16" ID, 3 ft (0.9 m) long, spring guards both ends	1
102	220–955	SPRAY GUN, airless <i>see 307–614 for parts</i>	1

*Extra warning labels available free.

**Motor brush kit 220–853 is available. Purchase separately.

PARTS DRAWING – LO-BOY SPRAYER

Model 231-054, Series D
 Basic Sprayer with Lo-Boy Cart
 Includes items 1 to 98

Model 231-055, Series B
 Complete Sprayer with Lo-Boy Cart
 Includes items 1 to 102

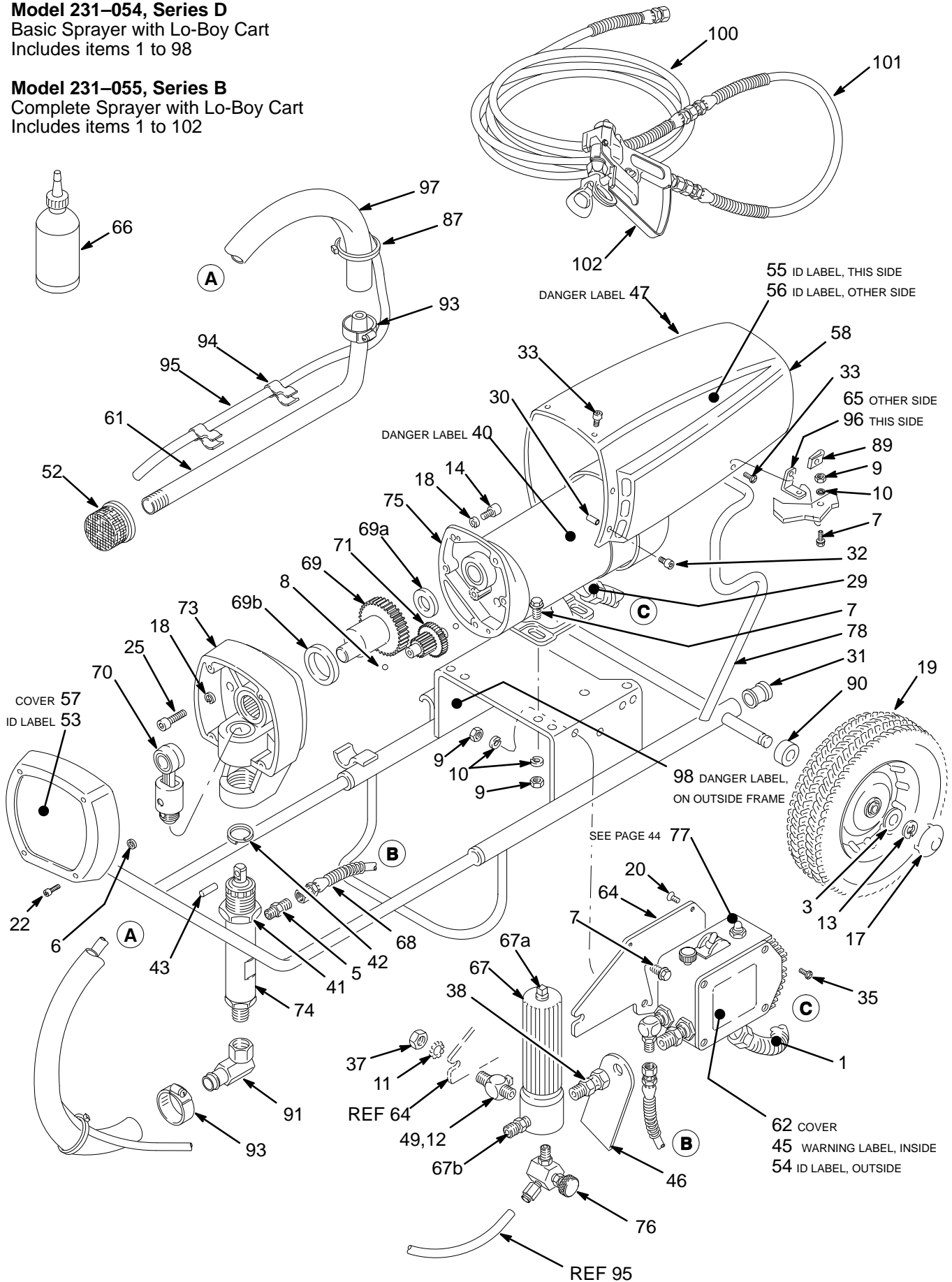

PARTS LIST – LO-BOY SPRAYER

Model 231–054, Series D

Includes items 1 to 98

REF NO.	PART NO.	DESCRIPTION	QTY
1	065–099	CONDUIT, <i>specify length when ordering</i>	0.8 ft
3	154–636	WASHER, 5/8" ID	2
5	156–823	UNION, 1/4 npsm swivel x 1/4 npt	1
6	109–014	SPACER	2
7	110–963	SCREW, hex head, no. 5/16–18 x .25"	9
8	100–069	BALL, stainless steel, 1/4" dia.	2
9	100–188	NUT, heavy hex, 5/16–18 unc–2a	9
10	100–214	LOCKWASHER, spring, 5/16"	9
11	100–322	LOCKWASHER, ext. shakeproof, 7/16"	1
12	100–509	.PLUG, square head, 1/4 npt(m)	1
13	101–242	RING, retaining	2
14	101–682	SCREW, socket head, 1/4–20 x 0.62"	2
15	101–754	PLUG, soc hd, 3/8 npt <i>see page 44</i>	1
17	104–811	HUBCAP	2
18	105–510	LOCKWASHER, spring, 1/4"	5
19	106–062	WHEEL, semi–pneumatic	2
20	106–078	SCREW, mach, ovhd, thd frm, no 6–24 x 1/2", type "C"	4
22	107–209	SCREW, mach, filh, no. 8–32 x 1"	4
23	107–258	TIP, grip <i>see page 44</i>	1
25	107–445	CAPSCREW, sch, 1/4–20 unrc–3a x 1.5"	3
26	107–447	SEAL, conduit <i>see page 44</i>	2
29	108–460	CONNECTOR, conduit, 45°	2
30	108–663	SPACER	2
31	105–521	PLUG, tubing, frame	2
32	108–709	SCREW, mach, pnh, 8–32 x 1"	2
33	108–865	SCREW, mach, pan head, no. 8 x 3/8"	6
35	110–037	SCREW, mach, pnh, 10–24 x .625"	4
37	150–513	NUT, jam, 7/16"	1
38	155–665	UNION, adapter, 3/8" npsm swivel x 3/8 npt(m)	1
39	162–453	NIPPLE, hex, 1/4 npsm x 1/4 npt	1
40	185–954*	LABEL, DANGER	1
41	176–762	NUT, hex, 1–1/2–18	1
42	176–817	SPRING, retaining	1
43	176–818	PIN, straight, hdls, 3/8" dia x 1"	1
45	177–762*	LABEL, WARNING	1
46	178–034	TAG, WARNING	1
47	185–952*	LABEL, DANGER	1
49	179–945	ADAPTER, elbow, special, 1/4–18 npt (m x f)	1
50	180–041	PIN, straight <i>see page 44</i>	1
52	187–146	STRAINER	1
53	181–607	LABEL, identification	1
54	181–608	LABEL, identification	1
55	181–609	LABEL, identification	1
56	181–610	LABEL, identification	1
57	181–611	COVER, housing	1
58	223–096	SHIELD, MOTOR, <i>includes items 30,32,33,47,55,56</i>	1
61	170–113	TUBE, suction	1
62	183–995	COVER, pressure control	1
64	183–365	BRACKET, mounting, pc	1

Model 231–055, Series B

Includes items 1 to 102

REF NO.	PART NO.	DESCRIPTION	QTY
65	185–470	BRACKET, shield	1
66	206–994	THROAT SEAL LIQUID, 8 oz. (0.27 liter)	1
67	214–570	FILTER, fluid <i>Includes items 67a – 67b see manual 307–273 for additional parts</i>	1
67a	100–040	.PLUG	1
67b	162–453	.NIPPLE, hex, 1/4 npsm x 1/4 npt	1
68	223–767	HOSE, grounded, nylon, 1/4" ID, 21.75" (736 m) long, cpd 1/4 npsm x 1/4 npt, spring guard both ends	1
69	218–242	CRANKSHAFT ASSEMBLY, <i>includes items 69a and 69b</i>	1
69a	180–131	.BEARING	1
69b	107–434	.BEARING	1
70	218–359	ROD, CONNECTING	1
71	218–364	GEAR REDUCER	1
72	218–405	CIRCUIT BOARD <i>see page 44</i>	1
73	223–100	DRIVE HOUSING <i>Includes item 73a</i>	1
73a	110–293	.GREASE <i>not shown</i>	1
74	222–584	DISPLACEMENT PUMP <i>see page 39 for parts</i>	1
75	222–678**	MOTOR, ELECTRIC, 1/2 HP <i>includes items 75a to 75c and one each of items 8 and 40</i>	1
75a	107–267	.TERMINAL, 0.187, 16–14 AWG	2
75b	107–504	.TERMINAL, 0.187, 22–18 AWG	1
75c	103–885	.TERMINAL, 0.250, 16–14 AWG	1
76	221–077	PRESSURE DRAIN VALVE	1
77	220–455	PRESSURE CONTROL <i>see parts list on page 44</i>	1
78	220–678	CART KIT <i>includes replaceable items 3,13,90,</i>	1
87	103–473	TIE, wire strap	3
89	110–240	SPEED NUT	2
90	183–275	SPACER	2
91	221–020	ELBOW, 90°, 1/2 npsm swivel x 3/4 npt(f)	1
93	103–927	CLAMP, hose	2
94	178–342	CLAMP, tube	2
95	183–281	TUBE, drain	1
96	185–499	BRACKET, shield	1
97	176–920	HOSE, suction	1
98	185–955*	LABEL, DANGER, French	1
100	223–541	HOSE, grounded, nylon, 1/4" ID, 50 ft (15 m) long, spring guard both ends	1
101	214–701	HOSE, grounded, nylon, 3/16" ID, 3 ft (0.9 m) long, spring guards both ends	1
102	220–955	SPRAY GUN, airless <i>see 307–614 for parts</i>	1

*Extra warning labels available free.

**Motor Brush Kit 220–853 is available. Purchase separately.

PARTS DRAWING & LIST – PRESSURE CONTROL

PRESSURE CONTROL ASSEMBLY 220–455

Includes all items listed below, except the terminals.

The terminals are included with the circuit board (item 72). The terminals listed in this parts list are shown on the wiring diagram on page 45.

Part numbers for items 15, 23, 26, 50, 72, 75a, 75b, and 75c shown in the drawings below are given on pages 41 and 43.

REF NO.	PART NO.	DESCRIPTION	QTY	REF NO.	PART NO.	DESCRIPTION	QTY
302	180-043	.MICROSWITCH	1	324	107-263	TERMINAL, female	1
303	105-679	.ON/OFF switch	1	325	102-799	TERMINAL, ring	1
304	105-659	.BOOT, switch	1	327	157-021	LOCKWASHER, no. 8, internal	1
305	107-255	.GUARD, locking	1	328	108-295	BUSHING, strain relief	1
306	218-168	JUMPER WIRE	1	331	101-273	SCREW, flat hd, no. 10-24 x 5/8"	2
308	218-170	RECTIFIER, bridge	1	332	100-179	NUT, hex, no. 10-24 thd	2
309	107-256	CIRCUIT BREAKER	1	333	100-718	LOCKWASHER, internal, no. 10	2
310	107-254	BOOT, circuit breaker	1	334	178-797*	LABEL, WARNING	1
311	218-169	CORD, power supply	1	335	178-035*	LABEL, WARNING	1
312	107-268	ADAPTER, terminal	1	336	107-261	TERMINAL, male	2
314	107-267	TERMINAL, female	1	337	107-503	TERMINAL, female	1
315	107-293	TERMINAL, female	2	338	107-504	TERMINAL, male	1
316	107-264	TERMINAL, male	1	341	157-350	ADAPTER, 3/8 npt(m) x 1/4 npt (m)	1
317	107-396	TERMINAL, male	1	342	100-840	ELBOW, street, 1/4 npt(m x f)	1
318	107-262	TERMINAL, female	1	343	100-035	SCREW, slotted pan hd, no. 8 x 5/16"	1
319	107-260	TERMINAL, female	1	344	162-453	NIPPLE, 1/4 npt(m) x 1/4 npsm	1
320	107-266	TERMINAL, female	1	345	108-460	CONNECTOR, conduit	1
321	103-885	TERMINAL, male	1				
322	103-886	TERMINAL, female	3				
323	107-265	TERMINAL, female	1				

*Extra warning labels available free.

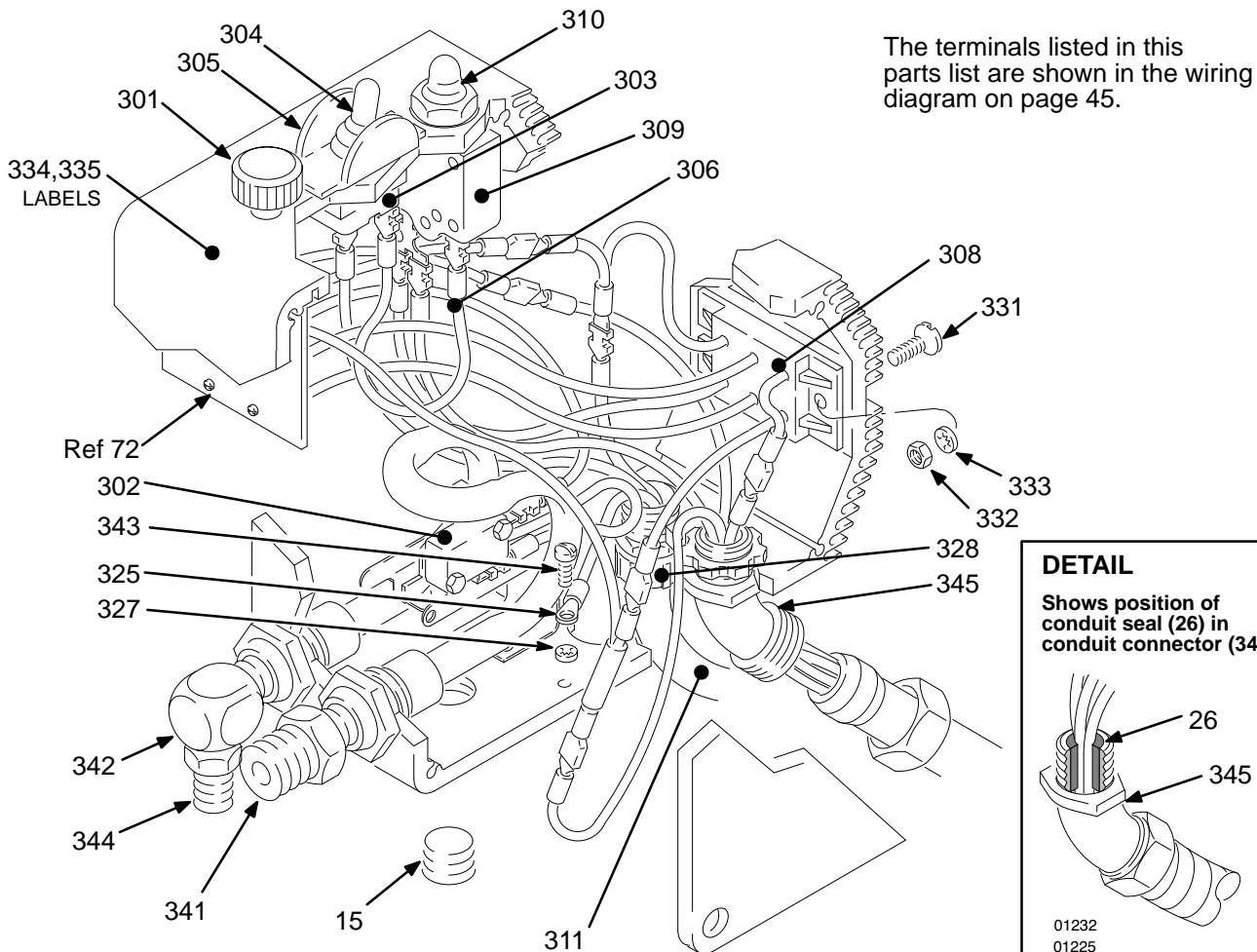

The terminals listed in this parts list are shown in the wiring diagram on page 45.

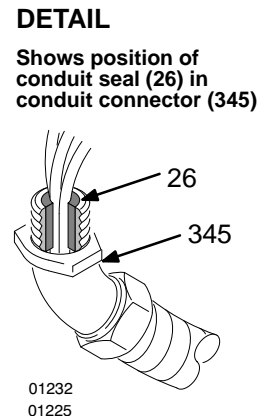

WIRING DIAGRAM

CIRCUIT BOARD 218-405, 5 WIRES

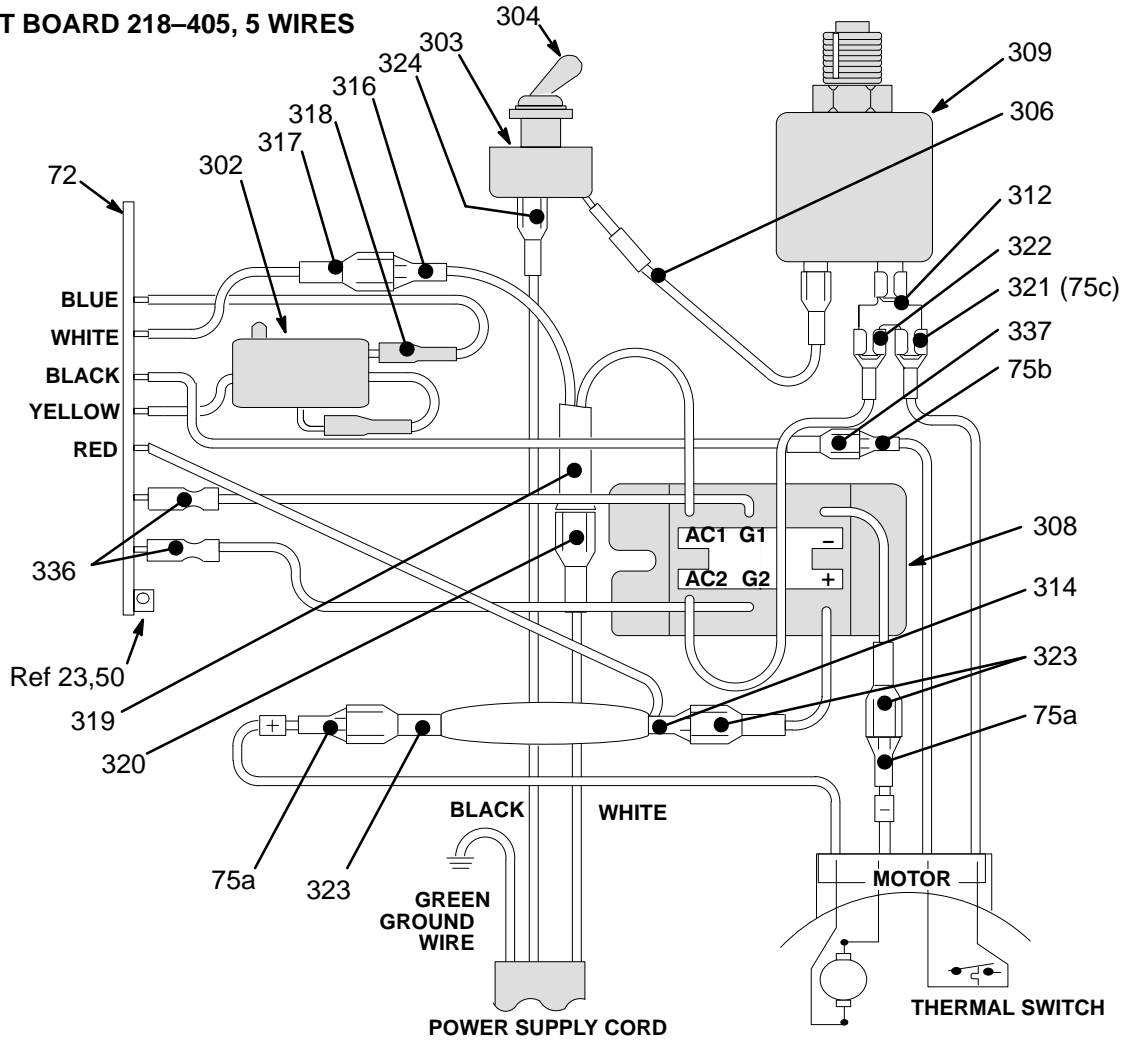

01221

ACCESSORIES

SUCTION TUBE KIT 208-259

55 gallon (200 liter) size

Includes:

Ref Part No. No.	Name	Qty
1 156-589	UNION	1
2 214-961	HOSE, 3/4 ID, 6 ft	1
3 156-591	ELBOW	1
4 156-593	PACKING	1
5 100-220	THUMBSCREW	1
6 176-684	ADAPTER	1
7 156-592	TUBE	1
8 159-100	RETAINER	1
9 161-377	SCREEN	1
10 159-101	NUT	1

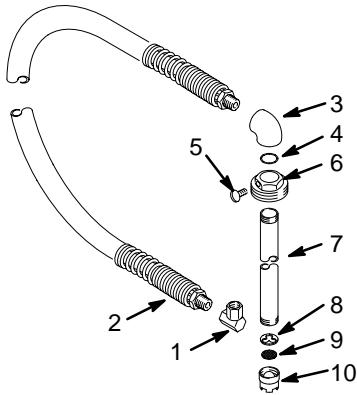

DANGER LABELS

The English language DANGER label shown on page 1 is also on your sprayer. If you have painters who do not read English, order one of the following labels to apply to your sprayer. The drawing shows the best placement of these labels for good visibility.

Order the labels directly from Graco, free of charge. Toll Free: 1-800-328-0211

Apply other language here

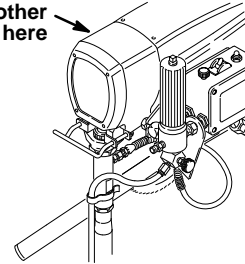

- French** 185-955
- Spanish** 185-962
- German** 186-042
- Greek** 186-046
- Korean** 186-050

0162

SUCTION TUBE 218-402

5 gallon (19 liter) size; includes manual

TECHNICAL DATA

Power Requirements	120 VAC, 60Hz, 1 phase, 15 amp minimum or 2500 Watt generator
Motor	1/2 HP, DC
Working Pressure Range	0 – 2750 psi (0 – 195 bar)
Cycles/Gallon (liter)	470 (124)
Maximum Delivery	1/2 GPM (1.9 liter/min)
Tip Size	one gun – 0.023 (with latex at 2000 psi (138 bar))
Power Cord	No. 14 AWG, 3 wire, 8'6" (2.6 m)
Inlet Paint Strainer	16 mesh (1190 micron) Stainless Steel Screen, reusable
Outlet Paint Filter	60 mesh (250 micron) Stainless Steel Screen, reusable
Pump Inlet Size	1/2 npt(m) with 30° ID chamfer
Fluid Outlet Size	1/4 npsm from fluid filter
Wetted Parts:	
Displacement Pump	Carbon steel, Polyurethane, Delrin®
Packing Material	Leather, UHMW polyethylene
Filter	Aluminum, Carbon steel, Stainless Steel 60 mesh (250 micron reusable SST screen)

NOTE: Delrin® is a registered trademark of the DuPont Co.

DIMENSIONS

	Upright Cart	LoBoy Cart
Height	29 in. (737 mm)	18 in. (457 mm)
Length	22 in. (559 mm)	27 in. (686 mm)
Width	20.5 in. (521 mm)	18 in. (457 mm)
Weight	83 lb (37 kg)	81 lb (36 kg)

GRACO PHONE NUMBERS

TO PLACE AN ORDER, contact your Graco distributor, or call this number to identify the distributor closest to you: **1-800-328-0211 Toll Free**.

FOR TECHNICAL ASSISTANCE, service repair information or assistance regarding the application of Graco equipment: **1-800-543-0339 Toll Free**

MANUAL CHANGE SUMMARY

Reactivated this manual from obsolete status because it is shipped with kits.

THE GRACO WARRANTY AND DISCLAIMERS

WARRANTY

Graco warrants all equipment manufactured by it and bearing its name to be free from defects in material and workmanship on the date of sale by an authorized Graco distributor to the original purchaser for use. As purchaser's sole remedy for breach of this warranty, Graco will, for a period of twelve months from the date of sale, repair or replace any part of the equipment proven defective, with the exception of defects in parts on the drive train/gear box on EM and GM sprayers or power train on EH & GH sprayers, which will be repaired or replaced for twenty-four months from the date of sale for Gas-Hydraulic (GH) and Gas Mechanical (GM) sprayers and for thirty-six months from the date of sale for Electric-Mechanical (EM) and Electric-Hydraulic (EH) Sprayers. This warranty applies only when the equipment is installed, operated and maintained in accordance with Graco's written recommendations.

This warranty does not cover, and Graco shall not be liable for, any malfunction, damage or wear caused by faulty installation, misapplication, abrasion, corrosion, inadequate or improper maintenance, negligence, accident, tampering, or substitution of non-Graco component parts. Nor shall Graco be liable for malfunction, damage or wear caused by the incompatibility with Graco equipment of structures, accessories, equipment or materials not supplied by Graco, or the improper design, manufacture, installation, operation or maintenance of structures, accessories, equipment or materials not supplied by Graco.

This warranty is conditioned upon the prepaid return of the equipment claimed to be defective to an authorized Graco distributor for verification of the claim. If the claimed defect is verified, Graco will repair or replace free of charge any defective parts. The equipment will be returned to the original purchaser transportation prepaid. If inspection of the equipment does not disclose any defect in material or workmanship, repairs will be made at a reasonable charge, which charges may include the costs of parts, labor and transportation.

DISCLAIMERS AND LIMITATIONS

THE TERMS OF THIS WARRANTY CONSTITUTE PURCHASER'S SOLE AND EXCLUSIVE REMEDY AND ARE IN LIEU OF ANY OTHER WARRANTIES (EXPRESS OR IMPLIED), INCLUDING WARRANTY OF MERCHANTABILITY OR WARRANTY OF FITNESS FOR A PARTICULAR PURPOSE, AND OF ANY NON-CONTRACTUAL LIABILITIES, INCLUDING PRODUCT LIABILITIES, BASED ON NEGLIGENCE OR STRICT LIABILITY. EVERY FORM OF LIABILITY FOR DIRECT, SPECIAL OR CONSEQUENTIAL DAMAGES OR LOSS IS EXPRESSLY EXCLUDED AND DENIED. IN NO CASE SHALL GRACO'S LIABILITY EXCEED THE AMOUNT OF THE PURCHASE PRICE. ANY ACTION FOR BREACH OF WARRANTY MUST BE BROUGHT WITHIN TWO (2) YEARS OF THE DATE OF SALE.

EQUIPMENT NOT COVERED BY GRACO WARRANTY

GRACO MAKES NO WARRANTY, AND DISCLAIMS ALL IMPLIED WARRANTIES OF MERCHANTABILITY AND FITNESS FOR A PARTICULAR PURPOSE, WITH RESPECT TO ACCESSORIES, EQUIPMENT, MATERIALS, OR COMPONENTS SOLD BUT NOT MANUFACTURED BY GRACO. These items sold, but not manufactured by Graco (such as electric motor, switches, hose, etc.) are subject to the warranty, if any, of their manufacturer. Graco will provide purchaser with reasonable assistance in making any claim for breach of these warranties.

Sales Offices: Atlanta, Chicago, Detroit, Los Angeles

Foreign Offices: Belgium, Canada, England, Korea, Switzerland, France, Germany, Hong Kong, Japan

GRACO INC. P.O. BOX 1441 MINNEAPOLIS, MN 55440-1441

PRINTED IN U.S.A. 307-758 July 1986, Revised July 2006