



This manual contains important warnings and information.
READ AND KEEP FOR REFERENCE.

INSTRUCTIONS

GM 5000 GASOLINE-POWERED AIRLESS LINSTRIPER LineLazer

3000 psi (210 bar, 21.0 MPa)
Maximum Working Pressure



Model 231-133, Series A

With one gun, RAC IV[®] DripLess[™] Tip guard,
Size 319 LineLazer Tip & Size 517 SwitchTip[™],
and 50 foot (15 m) hose.



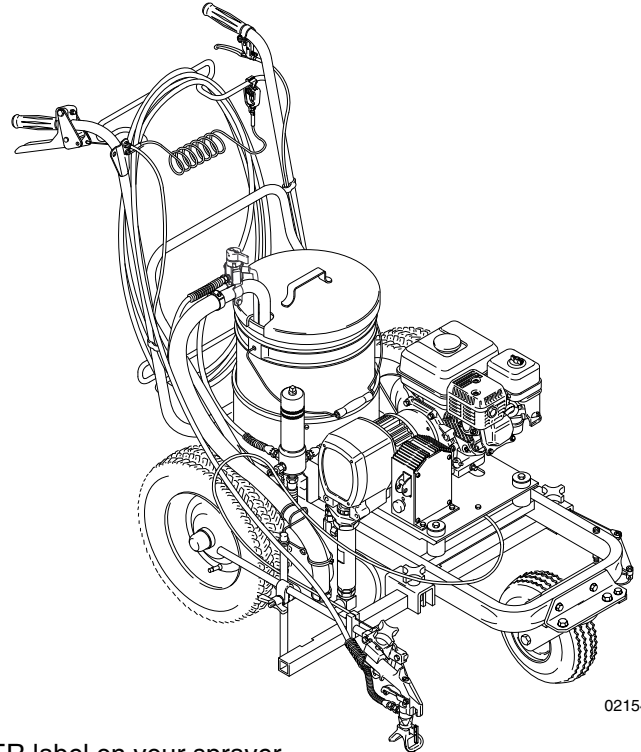

Model 231-141

Same as 231-133, except includes
Second Gun Kit, 224-097



02154C

NOTE: This is an example of the English language DANGER label on your sprayer. This label is supplied with the sprayer in other languages. Before operating the sprayer, apply a DANGER label in the appropriate language for you operators, according to the separate instructions supplied with it.

 DANGER 	
	FIRE AND EXPLOSION HAZARD
<p>Spray painting, flushing or cleaning equipment with flammable liquids in confined areas can result in fire or explosion.</p> <p>Use outdoors or in extremely well ventilated areas. Ground equipment, hoses, containers and objects being sprayed.</p> <p>Avoid all ignition sources such as static electricity from plastic drop cloths, open flames such as pilot lights, hot objects such as cigarettes, arcs from connecting or disconnecting power cords or turning light switches on and off.</p> <p>Failure to follow this warning can result in death or serious injury.</p>	<p style="text-align: center;"></p> <p>SKIN INJECTION HAZARD</p> <p>Liquids can be injected into the body by high pressure airless spray or leaks – especially hose leaks.</p> <p>Keep body clear of the nozzle. Never stop leaks with any part of the body. Drain all pressure before removing parts. Avoid accidental triggering of gun by always setting safety latch when not spraying.</p> <p>Never spray without a tip guard.</p> <p>In case of accidental skin injection, seek immediate “Surgical Treatment”.</p> <p>Failure to follow this warning can result in amputation or serious injury.</p>
READ AND UNDERSTAND ALL LABELS AND INSTRUCTION MANUALS BEFORE USE	

GRACO INC. P.O. BOX 1441 MINNEAPOLIS, MN 55440-1441

©COPYRIGHT 1990, GRACO INC.

Graco Inc. is registered to I.S. EN ISO 9001

Part Identification

Key

- A Caster lever
- B Dual gun selector
- C Main hose
- D Suction hose
- E Fluid filter
- F Pressure drain valve
- G Arm
- H Post
- J Carriage bar
- K Gun holder
- L Rac IV tip guard
- M Switch Tip
- N Flex gun
- O Displacement pump
- P Caster
- Q Dual gun selector cable
- R Pressure control
- S Spark plug cable
- T Air Cleaner
- U Muffler
- V Fuel Tank
- W Hook eyelet (use to strap pail or pail cover to cart)
- X Pail cover
- Y Caster Cable
- Z Grounding wire and clamp

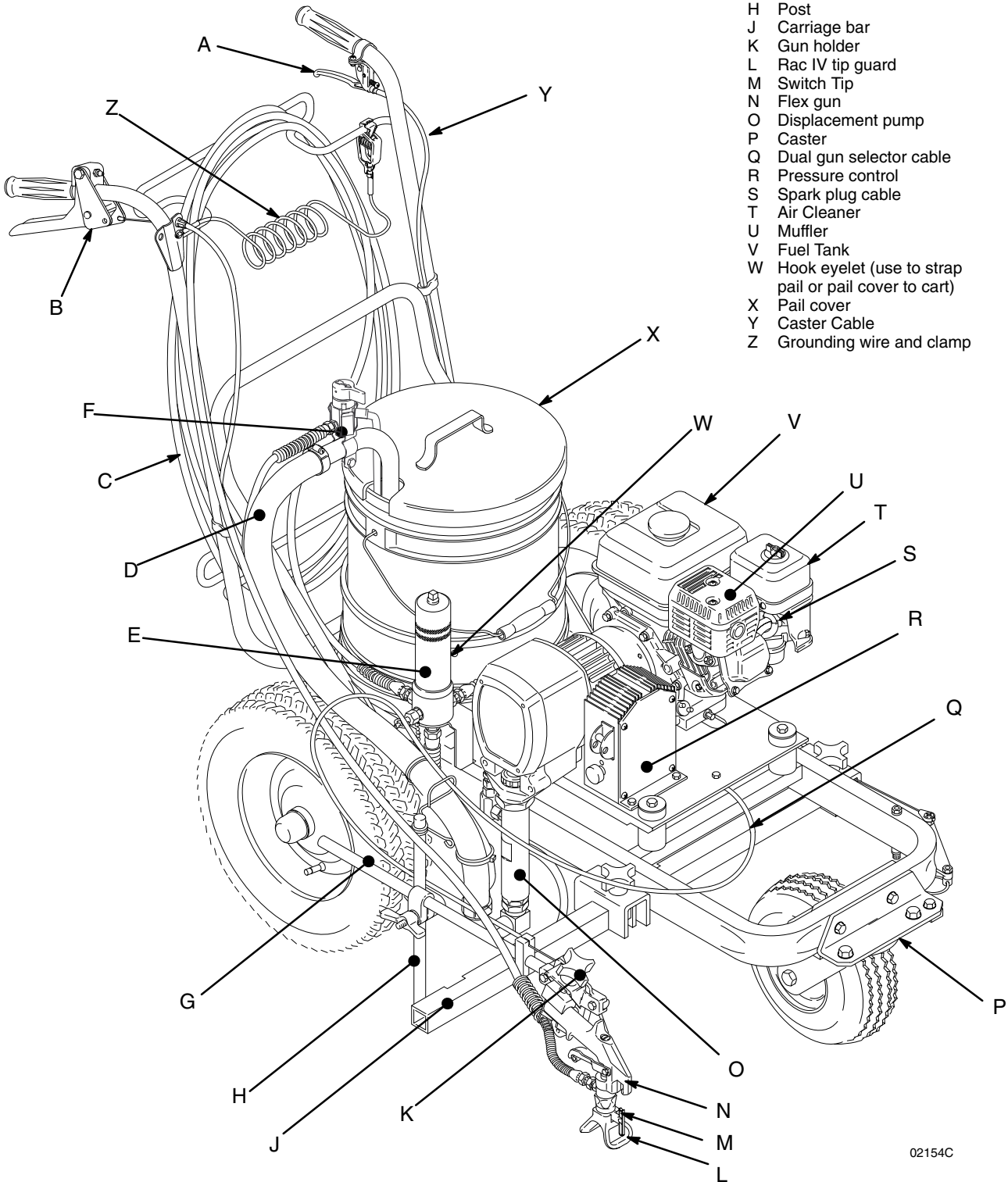

02154C

Table of Contents

Warnings	4	How to Mount the Gun	20
Setup	7	Gun Cable & Dual Gun Selector Operation	21
Fueling	10	How the Dual Gun Selector Works	21
Second Gun and Hose Installation	11	How to Release the Selector Cable	21
Flushing	12	Adjust the Trigger Cable Tension	22
Startup	13	Maintenance	23
Spray Tip and Tip Guard	15	Troubleshooting	24
Gasket Selection	15	Repair or Replacement	
Installation	15	Displacement Pump	26
Operation	15	Pressure Control	28
Clearing a Clogged Tip	15	Pressure Control Adjustment	29
Maintenance	15	Bearing Housing and Connecting Rod	30
Spray Tip Selection	16	Drive Housing	31
Spray Tip Application Recommendations ..	16	Pinion Housing	32
Spray Techniques	16	Clutch	34
Line Width Adjustment	16	Engine	36
Positioning the Gun Arm Assembly	17	Field & Wiring Harness	37
Vertical position of the first or second gun .	17	Clamp	38
Horizontal position of the first gun	17	Clutch Housing Removal	38
Horizontal position of the second gun	17	Reassembly	39
Mount guns on the engine side of the cart .	18	Parts	
Setup for spraying arcs	18	Displacement Pump Parts	42
Adjust Simultaneous Gun Triggering	18	Pressure Control Parts	43
Gun Arm Positions	19	Cart Parts	44
Caster Lever & Cable Operation	20	Mechanical Parts	46
Operation	20	Gun Mounting Parts	48
Maintenance	20	Pinion Parts	49
Caster Tire Replacement	20	Technical Data	50
Caster Cable Tension Adjustment	20	Accessories	50
Caster Alignment	20	Warranty	52

Manual Change Summary

- This manual was updated to include the changes from PCN M, except for 238–052 (CASTER, swivel).
- This manual was changed to include the updated pressure relief system per ECO F4963.
- Errors in the Parts Lists were corrected.

Symbols

Warning Symbol



This symbol alerts you to the possibility of serious injury or death if you do not follow the instructions.

Caution Symbol



This symbol alerts you to the possibility of damage to equipment if you do not follow the instructions.

WARNING



INSTRUCTIONS

EQUIPMENT MISUSE HAZARD

Equipment misuse can cause the equipment to rupture or malfunction and result in serious injury.

- This equipment is for professional use only.
- Read all instruction manuals, tags, and labels before operating the equipment.
- Use the equipment only for its intended purpose. If you are not sure, call your distributor.
- Do not alter or modify this equipment.
- Check equipment daily. Repair or replace worn or damaged parts immediately.
- Do not exceed the maximum working pressure of the lowest rated system component. Refer to the **Technical Data** on page 50 for the maximum working pressure of this equipment.
- Use fluids and solvents which are compatible with the equipment wetted parts. Refer to the **Technical Data** section of all equipment manuals. Read the fluid and solvent manufacturer's warnings.
- Do not use hoses to pull equipment.
- Route hoses away from traffic areas, sharp edges, moving parts, and hot surfaces. Do not expose Graco hoses to temperatures above 82°C (180°F) or below -40°C (-40°F).
- Do not lift pressurized equipment.
- Comply with all applicable local, state, and national fire, electrical, and safety regulations.
- Wear hearing protection when operating this equipment.
- Do not use 1,1,1-trichloroethane, methylene chloride, other halogenated hydrocarbon solvents or fluids containing such solvents in pressurized aluminum equipment. Such use could result in a chemical reaction, with the possibility of explosion.

WARNING



INJECTION HAZARD

Spray from the gun, leaks or ruptured components can inject fluid into your body and cause extremely serious injury, including the need for amputation. Fluid splashed in the eyes or on the skin can also cause serious injury.

- Fluid injected into the skin may look like just a cut, but it is a serious injury. **Get immediate medical attention.**
- Do not point the gun at anyone or at any part of the body.
- Do not put your hand or fingers over the spray tip.
- Do not stop or deflect leaks with your hand, body, glove or rag.
- Do not “blow back” fluid; this is not an air spray system.
- Always have the tip guard and the trigger guard on the gun when spraying.
- Check the gun diffuser operation weekly. Refer to the gun manual.
- Be sure the gun trigger safety operates before spraying.
- Lock the gun trigger safety when you stop spraying.
- Follow the **Pressure Relief Procedure** on page 7 if the spray tip clogs and before cleaning, checking or servicing the equipment.
- Tighten all fluid connections before operating the equipment.
- Check the hoses, tubes, and couplings daily. Replace worn or damaged parts immediately. Do not repair high pressure couplings; you must replace the entire hose.
- Fluid hoses must have spring guards on both ends, to help protect them from rupture caused by kinks or bends near the couplings.



TOXIC FLUID HAZARD

Hazardous fluid or toxic fumes can cause serious injury or death if splashed in the eyes or on the skin, inhaled, or swallowed.

- Know the specific hazards of the fluid you are using.
- Store hazardous fluid in an approved container. Dispose of hazardous fluid according to all local, state and national guidelines.
- Always wear protective eyewear, gloves, clothing and respirator as recommended by the fluid and solvent manufacturer.



FUEL HAZARD

The fuel used in this unit is combustible and when spilled on a hot surface can ignite and cause a fire.

- Do not fill the fuel tank while the engine is running or hot.



EXHAUST HAZARD

The exhaust contains poisonous carbon dioxide which is colorless and odorless.

- Do not operate this equipment in a closed building.

WARNING



FIRE AND EXPLOSION HAZARD

Improper grounding, poor ventilation, open flames or sparks can cause a hazardous condition and result in a fire or explosion and serious injury.



- If there is any static sparking or you feel an electric shock while using this equipment, **stop spraying immediately**. Do not use the equipment until you identify and correct the problem.
- Provide fresh air ventilation to avoid the buildup of flammable fumes from solvents or the fluid being sprayed.
- Keep the spray area free of debris, including solvent, rags, and gasoline.
- Disconnect all electrical equipment in the spray area.
- Extinguish all open flames or pilot lights in the spray area.
- Do not smoke in the spray area.
- Do not turn on or off any light switch in the spray area while operating or if fumes are present.
- Do not operate a gasoline engine in the spray area.
- Ground the sprayer to a true earth ground with the ground wire and clamp (supplied).
- Use only electrically conductive hoses.



MOVING PARTS HAZARD

Moving parts can pinch or amputate your fingers.

- Keep clear of all moving parts when starting or operating the sprayer.
- Before servicing the equipment, follow the **Pressure Relief Procedure** on page 7 to prevent the equipment from starting unexpectedly.

Setup

General Information

NOTE: Reference numbers and letters in parentheses in the text refer to the callouts in the figures and the parts drawing.

NOTE: Always use Genuine Graco Parts and Accessories, available from your Graco distributor.

Grounding

⚠ WARNING



FIRE AND EXPLOSION HAZARD
Before operating the pump, ground the system as explained below. Also read the section **FIRE OR EXPLOSION HAZARD** on page 6.

1. *Sprayer:* make sure the grounding chain (106) contacts the ground while the unit is moving. See Page 46. For stationary spraying, connect a ground wire and clamp (159) to a true earth ground.
2. *Fluid hoses:* use only grounded hoses with a maximum of 500 ft. (150 m) combined hose length to ensure grounding continuity.
3. *Spray gun:* obtain grounding through connection to a properly grounded fluid hose and sprayer.
4. *Object being sprayed:* according to local code.
5. *Fluid supply container:* follow your local code.
6. *Solvent pails used when flushing:* follow your local code. Use only metal pails, which are conductive, placed on a grounded surface. Do not place the pail on a nonconductive surface, such as paper or cardboard, which interrupts the grounding continuity.
7. *To maintain grounding continuity when flushing or relieving pressure,* hold a metal part of the spray gun firmly to the side of a grounded *metal* pail, then trigger the gun.

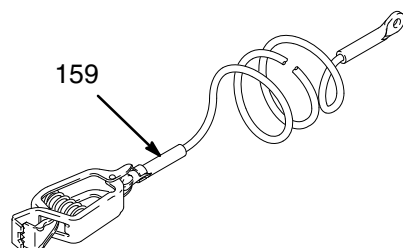

Fig. 1

Pressure Relief Procedure

⚠ WARNING

INJECTION HAZARD
Fluid under high pressure can be injected through the skin and cause serious injury. To reduce the risk of an injury from injection, splashing fluid, or moving parts, follow the **Pressure Relief Procedure** whenever you:

- are instructed to relieve the pressure,
- stop spraying,
- check or service any of the system equipment,
- or install or clean the spray tips.

1. Engage the spray gun safety latch.
2. Turn the ON/OFF switch to OFF.
3. Flip the pressure control switch to OFF.
4. Disengage the gun safety latch. Hold a metal part of the gun firmly to the side of a grounded metal pail, and trigger the gun to relieve pressure.
5. Engage the gun safety latch.
6. Hold the pressure relief tube firmly to the side of a grounded metal pail, and open the pressure relief valve. Leave the valve open until you are ready to spray again.
7. Disconnect the spark plug cable to prevent the system from starting unexpectedly.

*If you suspect that the spray tip or hose is completely clogged, or that pressure has not been fully relieved after following the steps above, **very slowly** loosen the tip guard retaining nut or hose end coupling and relieve pressure gradually, then loosen completely. Now clear the tip or hose.*

Valve shown in CLOSED position. **Valve shown in OPEN position.**

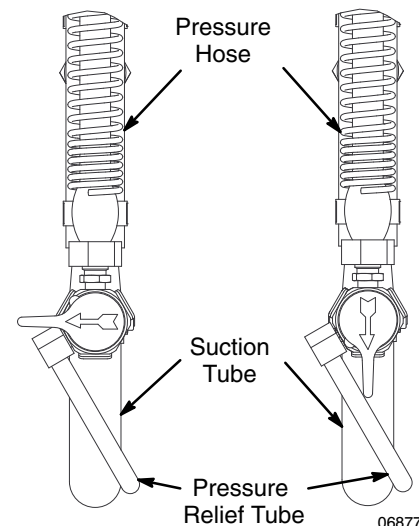

Fig. 2

Setup

1. Read and follow the warnings on pages 4–6 before installing or operating this sprayer.
2. Unpack the LineLazer Carefully raise the handle (19) to a vertical position. Four screws (39) and locknuts (40) are packed in a bag. Install the two rear screws (39A) and finger tighten the nuts (40A). Install one screw (39B) and nut (40B) on each side of the handle. Firmly tighten all four nuts. See Fig. 3.

⚠ CAUTION

When raising the cart handle (19), be sure no cables are caught on the frame or become kinked.

3. To install a second gun and hose, see page 11.
4. Fill the packing nut/wet-cup (216) 1/3 full with Graco Throat Seal Liquid (TSL), supplied, and keep it filled, to help extend the pump life. See Fig. 4.
5. Check the engine oil level. Refer to the Honda engine manual, supplied. This is a summary of the information: Remove one of the oil fill plugs (A); the oil should be almost overflowing. See Fig. 4. Add oil as necessary. Also read the **Maintenance** section on page 23.

Recommended engine oil: Use a high-quality, detergent oil, SAE 10W–40, classified “FOR SER VICE SE or SF”.

6. Ground the sprayer. Proper grounding is essential to maintaining an electrically safe system. Also read and follow **FIRE OR EXPLOSION HAZARD** on page 6.

⚠ WARNING

Ground the sprayer whenever it is used indoors, either as a moving line striper or as a stationary sprayer. Floors in most factories are coated, which causes them to be poor electrical conductors. This increases the risk of hazardous static electric discharge, which can result in serious injury, fire, or explosion and property damage.

Whenever you flush: connect the ground clamp (159) to a true earth ground.

Using as an outdoor striper: Be sure the static chain attached to the bottom of the cart drags on the ground to help dissipate static electricity. Ground the sprayer to a true earth ground if specified by your local electrical code.

Indoor spraying: Ground the sprayer whenever the sprayer is used indoors. The ground wire supplied with the sprayer is not long enough to allow much operator movement. Therefore, the operator must provide a longer ground wire or provide some other method of effective electrical grounding as specified by your local electrical code.

7. Provide adequate ventilation when spraying indoors.

⚠ WARNING

If the LineLazer is used indoors, you must vent the exhaust to the outdoors or provide adequate ventilation as specified by you local code. This is to reduce the risk of carbon monoxide poisoning.

8. Fill the gas tank. See **Fueling** on page 10.
9. Flush the pump to remove the lightweight oil which was left in the pump to protect it from rust. Follow the **Flushing** on page 12.
10. Prepare the paint according to the manufacturer’s recommendations. Remove any skin that may have formed. Stir the paint to mix pigments.

Strain the paint through a fine nylon mesh bag (available at most paint dealers) to remove particles that could clog the filter or spray tip. This is an important step toward trouble-free spraying.

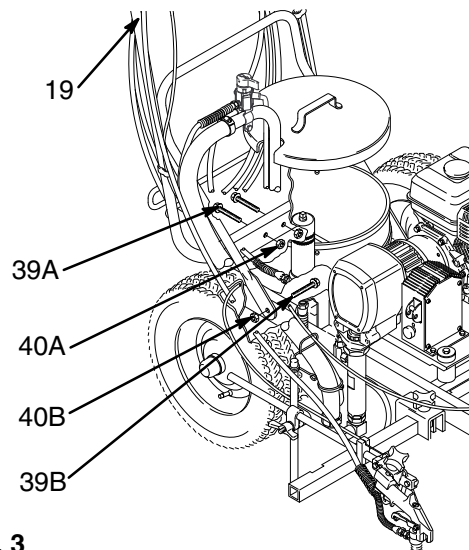

Fig. 3

02491B

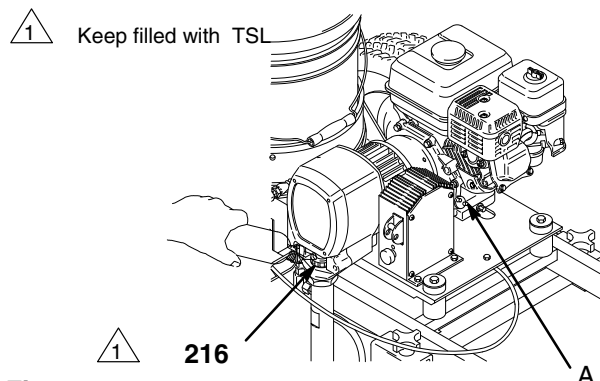

Fig. 4

0008

Setup

11. Observe the following cautions to avoid pressure control damage.

⚠ CAUTION

To avoid damaging the pressure control, follow these precautions.

- Allow the main hose to act as a pulsation dampener: Always use nylon spray hose at least 50 ft. (15 m) long for the main gun; Never use a wire braid hose; it is too rigid.
- Never install a ball valve or shutoff device between the filter and the 50 ft. (15 m) hose.
- Do not allow water or water-base material to freeze in the pressure control.

⚠ CAUTION

Close the black fuel shutoff lever whenever you are transporting the sprayer to prevent fuel from flooding the engine.

Keep the sprayer upright and level when operating it and transporting it. This prevents crankcase oil from leaking into the combustion chamber, which makes startup very difficult.

12. To use the wheel brake, lift the brake handle (A—bottom rear of cart) to engage the brake. Lower the handle to disengage the break. See Fig. 5. For positive break engagement, be sure there is proper tire pressure and that tire wear is not excessive.

13. For how to operate and adjust the various features of the LineLazer see pages 11–22.

14. Start the sprayer. See page 13.

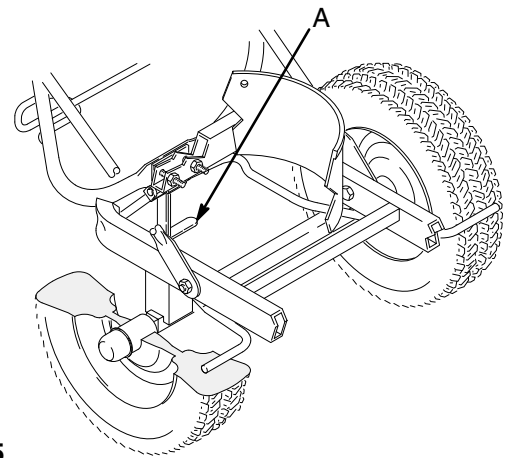

Fig. 5

03586

Fueling

⚠ WARNING

Gasoline is extremely flammable and explosive under certain conditions. To reduce the risk of a fire or explosion:

1. Always shut off the engine before refueling.
 2. Refuel in a well-ventilated area.
 3. Do not smoke or allow flames or sparks in the area where the engine is refueled or where gasoline is stored.
 4. Do not overfill the tank. Make sure the filler cap is securely closed after refueling.
 5. Fuel vapor or spilled fuel can ignite. If any fuel is spilled during refueling, make sure the area is dry before starting the engine.
1. Fuel specifications. Use automotive gasoline with a pump octane number of 86 or higher. If the engine knocks or pings, use a higher octane fuel. Unleaded fuel minimizes combustion chamber deposits.
 2. Gasolines containing alcohol (gasohol). Do not use gasohol which contains methanol, if the gasohol does not contain cosolvents and corrosion inhibitors for methanol. Even if it does contain such additives, do not use the gasohol if it contains more than 5% methanol.

NOTE: The HONDA engine warranty does not cover damage resulting from the use of gasolines containing alcohol. See the HONDA engine manual for more information.

3. General. Do not use oil and gasoline mixtures or contaminated gasoline. Avoid getting dirt, dust or water in the fuel tank.
4. Tank capacity: 0.95 gallons (3.6 liter). Leave 1/2 in. (13 mm) at the top of the tank for gas expansion.
5. Shut off the engine switch (A) before refueling.
6. After refueling, tighten the fuel tank cap (B) firmly.

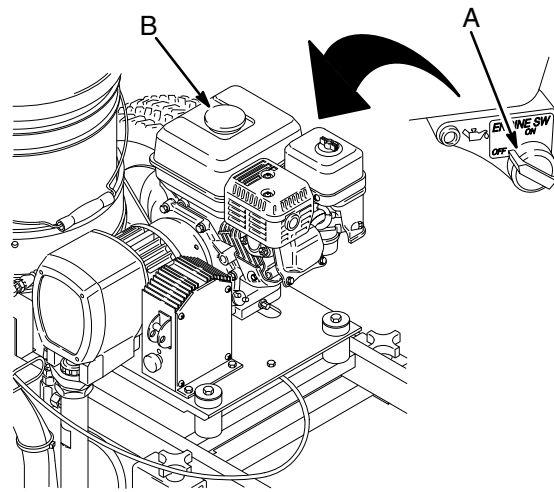

Fig. 6

0009

Second Gun and Hose Installation

NOTE: Fig. 7 represents the installation at Step 3.

NOTE: To switch the gun assemblies to the engine side of the cart, refer to the instructions on page 17 before installing the second gun kit.

1. Disengage the trigger cable from the block (48) of the unit's existing gun. See page 21. Engage the gun's trigger safety latch.
2. Loosen the carriage clamps (B, C). Slide the carriage bar (4) off the cart.
3. For mounting the second gun bar on the pump side of the cart: Slide a clamp (405A) onto the carriage bar (4). Slide the carriage bar through the pump-side carriage clamp (B) and into the center of the cart. Now slide another clamp (405B) onto the carriage bar. See Fig. 7.

For mounting the second gun bar on the engine side of the cart: Follow Step 3, except slide the carriage bar through the engine-side carriage clamp (C) and the into the center of the cart. The knobs of the clamps (405A, 405B) must face back toward the handle bars.

4. Slide the carriage bar (4) through to the opposite carriage clamp. Tighten the carriage clamps (B,C).
5. Slide the second gun bar (404) far enough into the carriage bar that the clamp (405B) engages the bar. Position the clamps (405A, 405B) over the notches (A) in the carriage bar (4) and tighten the clamps.

NOTE: For stable gun operation, the second gun bar (404) has a maximum recommended extension from the carriage bar of about 11-¹/₄" (286 mm).

6. Disconnect the trigger cable from the second gun at the screw (34). See Fig. 7 DETAIL B.
7. Unscrew the filter's second outlet cap (14). Screw the short hose (403) onto the filter nipple.
8. Remove the guide clamp screw (27).
9. Snap the cable bushing (E) into the guide plate (D). Route the trigger cable (402) parallel with the main gun cable, separating the guide clamp (104) to feed the cable through it. Install and tighten the clamp screw (27). Route the cable through the cable guide (7) and to the second gun.
10. Slide the hooked end of the cable (402) through the hole (F) in the lever plate (122). Rotate and slide the hook back until it engages the plate. See DETAIL A.
11. Reconnect the trigger cable to the second gun at screw (34). Torque the screw to 15 in-lb (1.7 N.m), back it off 1/16 to 1/8 turn and then tighten the jam nut (99) while holding the screw (34). Be sure the plate (94) moves freely.
12. Install the clip (401) to hold the cable onto the frame.
13. Connect both trigger cables to the blocks (48). Then adjust the cable tension. See pages 20–22.
14. Do not install the spray tip until the system is primed.
15. Adjust simultaneous gun triggering. See page 18.

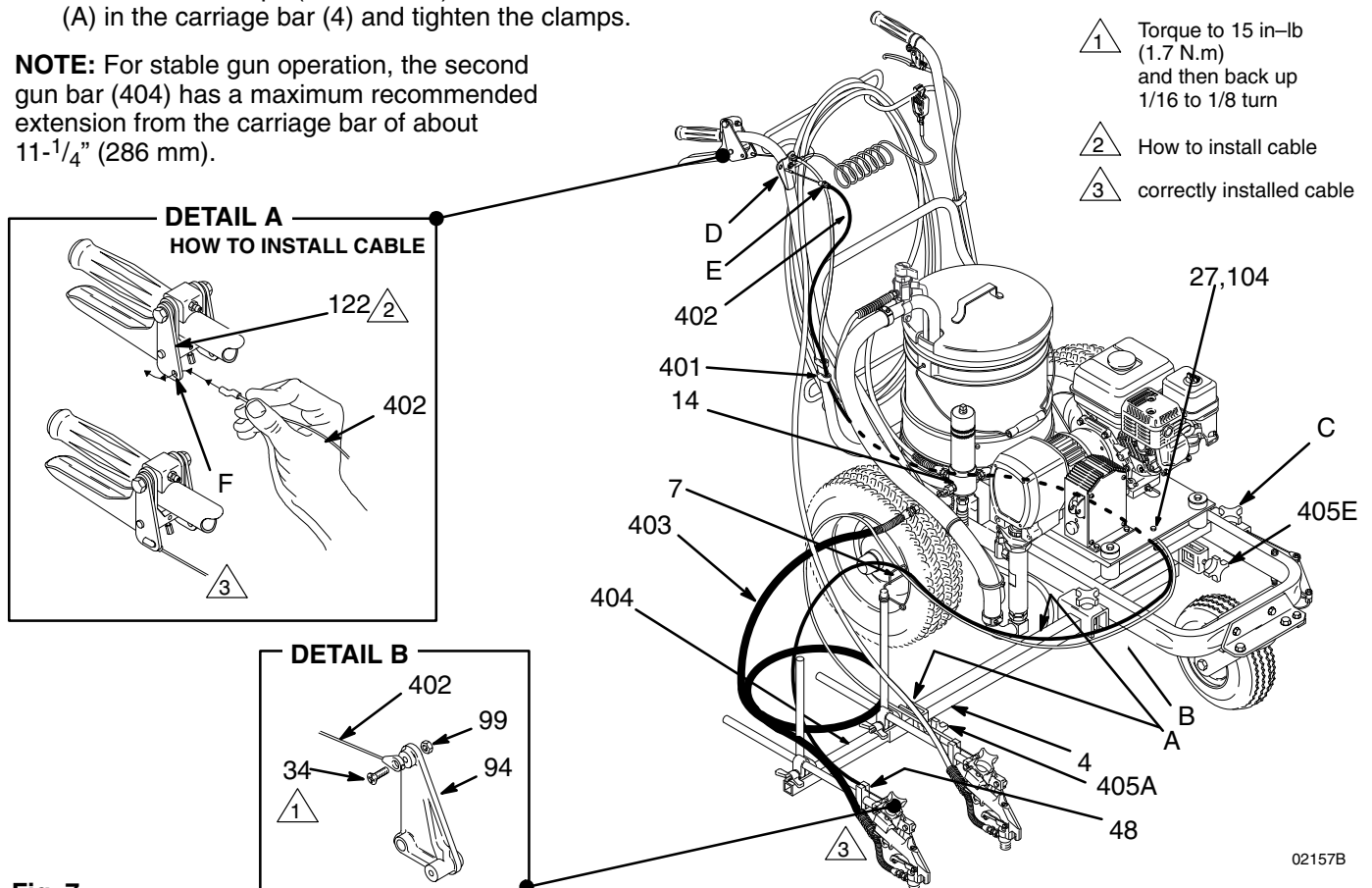

Fig. 7

02157B

Flushing

⚠ WARNING

To reduce the risk of serious injury whenever you are instructed to relieve pressure, always follow the **Pressure Relief Procedure** on page 7.

Be sure the pump is properly grounded.

⚠ CAUTION

Never leave water in the sprayer if there is any chance it could freeze. Push the water out with compatible solvent. Water frozen in the pressure control tube prevents the sprayer from being started, and causes serious damage to the pressure control.

When to Flush

1. Flush a new sprayer to remove the protective oil.
Before using water-base paint, use compatible solvent, then soapy water, and then clean water.
Before using oil-base paint, use compatible solvent.
2. Changing colors. Use a compatible solvent.
3. Changing from water-base to oil-base paint. Use warm, soapy water, and then a compatible solvent.
4. Changing from oil-base to water-base paint. Use a compatible solvent, then warm, soapy water, and then clean water.
5. Storage. After the compatible solvent flush, relieve pressure, but do not drain the compatible solvent.
6. Startup after storage.
Before using water-base paint, flush out the compatible solvent with soapy water, and then with clean water.
When using oil-based paint, flush out the compatible solvent with the paint to be sprayed.

How to Flush

1. Relieve pressure.
2. Remove the filter bowl (A) and screen (B); see manual 307-273. Install the bowl and support (C), without the screen, to flush it. Clean the screen separately. See Fig. 8.
3. Close the pressure drain valve (13).
4. Put the suction tube in a grounded pail of water or solvent.
5. Remove the gun(s) from the holder. Remove the spray tip(s) to prevent splashing.

⚠ WARNING

To reduce the risk of static sparking and splashing when flushing, always remove the spray tip from the gun, and hold a metal part of the gun firmly to the side of, and aimed into, a grounded metal pail.

6. Follow **Startup** on page 13. Keep the gun triggered until clean water or solvent comes from the nozzle. See Fig. 9. Release the trigger and engage the gun safety latch.

NOTE: If you have two guns, release the trigger safety latch on the second gun and trigger that gun until clean water or solvent comes from the nozzle. To ensure that the hoses are well-flushed, flush the first gun and then the second gun at least one more time.

7. Check all fluid connections for leaks. Relieve pressure before tightening any connections. Start the sprayer. Recheck the connections for leaks.
8. Remove the suction tube from the solvent pail. Disengage the gun safety latch. Trigger the gun to force water or solvent from the hose. Do not let the pump run dry for more than 30 seconds to avoid damaging the pump packings! Relieve pressure.

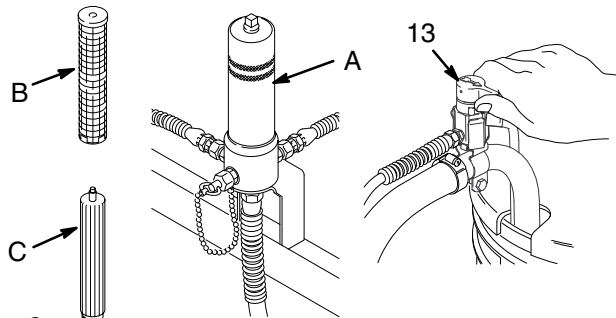

Fig. 8

0013

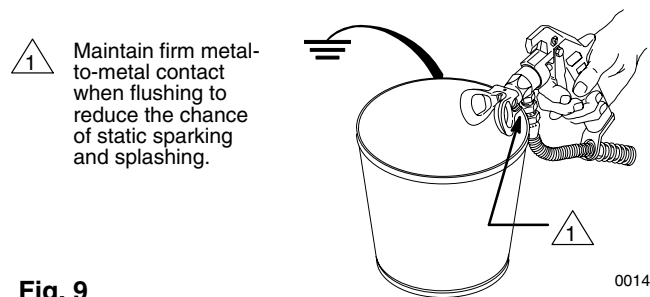

Fig. 9

0014

9. If you have been spraying paint, remove the strainer, suction tube and suction hose and clean them separately to be sure all paint sediment is removed. Dried paint in the suction tube assembly can build up and cause performance problems later on.
10. Install the clean filter screen. Install the filter bowl and hand tighten.
11. See Storage or Changing Colors, above. Relieve pressure.

Startup

Before You Start the Linestriper

1. See Flushing, page 12, to determine if the Line Lazer should be flushed.
2. Be sure the gas tank is full.
3. Check the engine oil level.

NOTE: The engine stops automatically, or will not start, if it is low on oil. If you try to start it again without adding more oil, a red light (A) near the engine on/off switch glows as you pull the starter rope.

4. Be sure the spark plug cable (J) is firmly pushed onto the spark plug.

Startup See Fig. 10

1. When starting a sprayer that IS NOT PRIMED, remove the spray tip.
2. Place the suction tube (S) into the paint, water or solvent container, depending on whether you are flushing or are ready to spray.
3. Open the black fuel shutoff lever (E) by pushing it in the direction of the arrow.

CAUTION

Never start the engine unless fluid pressure is relieved and the pressure control switch is turned OFF. Attempting to start the engine when it is pressurized could damage the electrical system.

4. Turn OFF the pressure control switch (K).
5. To start the engine:
 - a. Turn the pressure adjusting knob (L) all the way counterclockwise to the lowest pressure setting.
 - b. Slide the metal throttle lever (C) away from the fuel tank to the maximum position (fully left).
 - c. If the engine is cold, close the choke by moving the gray lever (D).
 - d. If the engine is warm, close the choke by moving the gray lever (D) only half way or not at all.
 - e. Turn ON the engine switch (B).

WARNING

A rope that recoils too quickly may hit someone and cause serious bodily injury. The rope could also jam in the recoil assembly.

- f. Hold the frame of the sprayer with one hand and pull the starter rope (G) rapidly and firmly. Continue holding the rope as you let it return. Pull and return the rope until the engine starts.

- g. Open the choke as soon as the engine starts, except in cold weather. In cold weather, leave the choke closed for 10 to 30 seconds before opening it to keep the engine running.
6. Release the trigger cable and engage the gun trigger safety latch. See page 21.
 7. Remove the gun from the holder by unscrewing the gun holder knob and lifting out the gun.
 8. **To start the pump:**

NOTE: Lower the throttle setting for easier priming.

- a. Open the pressure drain valve (R).
- b. Turn ON the pressure control switch (K).
- c. Turn the pressure control knob (L) about 1/4 turn from minimum pressure. Run the pump until fluid is flowing smoothly from the pressure drain valve, indicating the pump is fully primed.
- d. Close the pressure drain valve (R).
- e. Disengage the gun safety latch. Hold a metal part of the gun firmly against a grounded metal pail, squeeze the trigger until fluid flows from the gun.
- f. Release the trigger. Engage the safety latch.

NOTE: If you are using two guns, follow Step e and f, above, for the second gun.

9. If you have not primed the sprayer with paint yet, move the suction tube (S) to the paint container. Release the trigger safety latch. Trigger the gun into the water/solvent pail just until paint appears. Release the trigger and engage the trigger safety latch. Repeat for the second gun, if two guns are used.
10. Place the pail cover (F) on the pail.

WARNING

To reduce the risk or serious injury from fluid injection, never operate the spray gun with the tip guard removed.

11. Install the tip guard and spray tip (M). See page 15.
12. Mount the gun in the gun holder. See page 20.
13. Engage the trigger cable. See page 21.

CAUTION

Always use the lowest fluid pressure and the lowest throttle setting needed. Higher settings cause excessive clutch cycling, premature tip wear and premature pump wear.

14. Adjust the engine speed and pump pressure. Trigger the gun onto a test paper to check the spray pattern and atomization. Turn the pressure adjusting knob (L) until you get a good pattern. Then slowly lower the throttle setting (C) as far as you can without changing the spray pattern.

Startup

15. Read **Spray Techniques** on page 16.

⚠ CAUTION

Close the black fuel shutoff lever (E) whenever you are transporting the sprayer to prevent fuel from flooding the engine.

Keep the sprayer upright and level when operating it and when transporting it. This prevents crankcase oil from leaking into the combustion chamber, which makes start up very difficult.

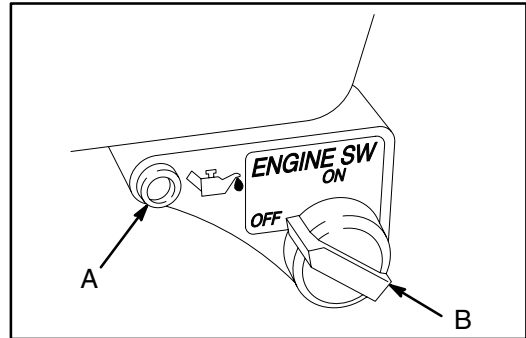

—AT REAR OF ENGINE—

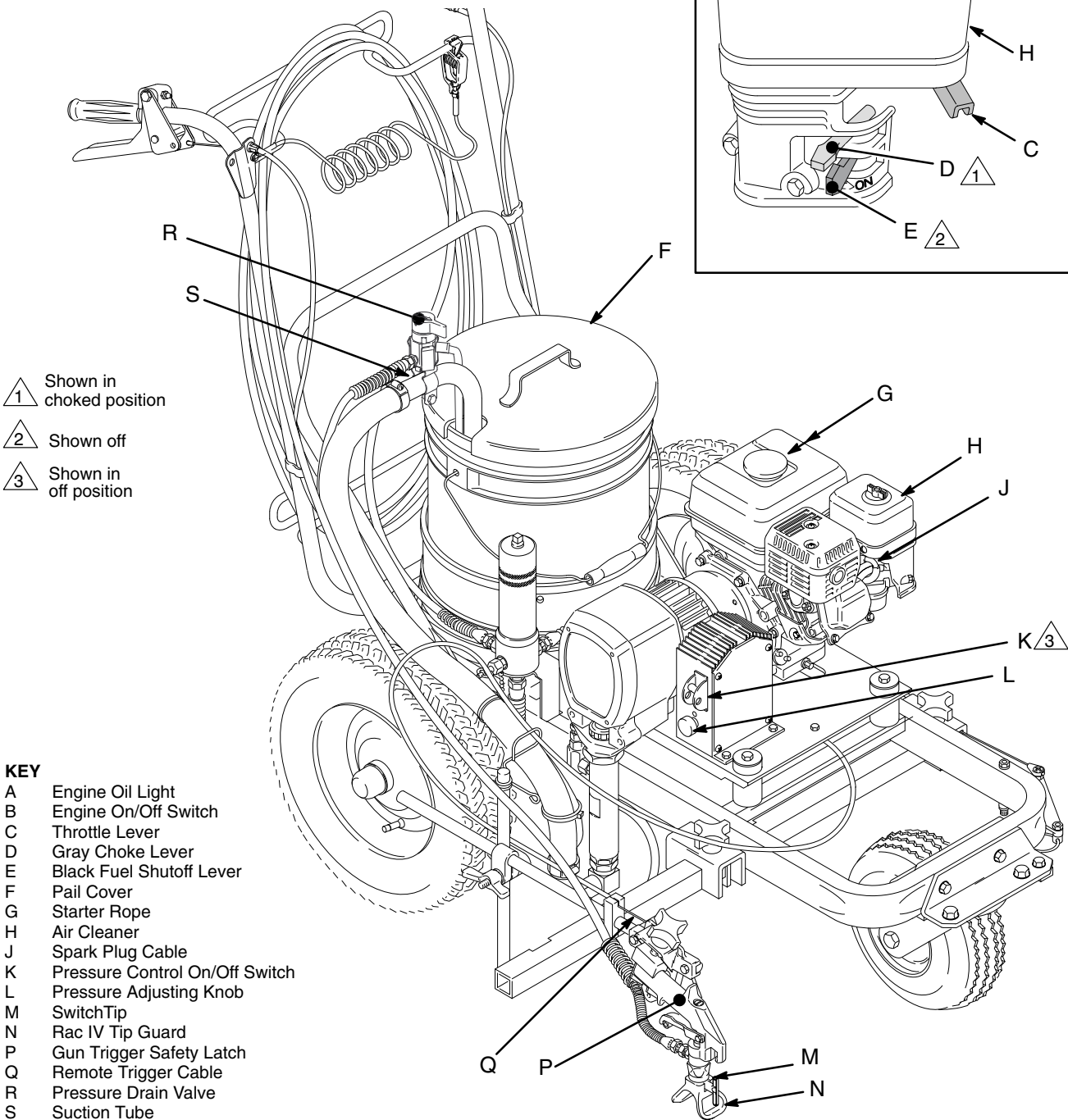
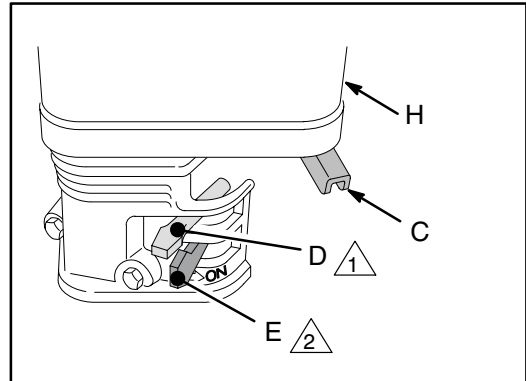

1 Shown in choked position

2 Shown off

3 Shown in off position

KEY

- A Engine Oil Light
- B Engine On/Off Switch
- C Throttle Lever
- D Gray Choke Lever
- E Black Fuel Shutoff Lever
- F Pail Cover
- G Starter Rope
- H Air Cleaner
- J Spark Plug Cable
- K Pressure Control On/Off Switch
- L Pressure Adjusting Knob
- M Switch Tip
- N Rac IV Tip Guard
- P Gun Trigger Safety Latch
- Q Remote Trigger Cable
- R Pressure Drain Valve
- S Suction Tube

Fig. 10

02154C

Spray Tip and Tip Guard

⚠ WARNING

To reduce the risk of serious injury whenever you are instructed to relieve pressure, always follow the **Pressure Relief Procedure** on page 7.

⚠ WARNING

Failure to install or use the RAC IV tip guard assembly correctly may result in an undirected spray of paint into the eyes or on the skin of the operator. Be sure you:

- Use the appropriate gasket for the solvent used.
- Fully insert the tip into the guard.
- Fully tighten the guard onto the gun nozzle using a wrench.
- Turn the handle so it is parallel to the gun nozzle.
- When replacing a worn spray tip, always install a new gasket and seat.

Gasket Selection

⚠ WARNING

To reduce the risk of fluid splashback into the eyes or on the skin, use the appropriate gasket as specified in the following text.

Use the black rubber gasket (D) ONLY with latex and oil-based paints, stoddard solvents, mineral spirits, turpentine and water. When using this gasket, the spray tip can be removed and replaced without using tools.

Use the red or yellow plastic gasket (C) with the same fluids as above and with most other solvents, including lacquer thinner, trichloroethylene, MEK, acetone, brush cleaner, xylol. When using this gasket, loosen the RAC IV retaining nut to remove the spray tip.

Installation

Relieve pressure. Install a tip (F) so the flange (G) on the cylinder fits into the slots (H) at the base of the spray tip guard (J). See Fig. 11.

Place the seat (E) on a pencil, curved side out, as shown in Fig. 12. Guide the seat into the retaining nut (A) and turn the seat until it straddles the cylinder of the spray tip (F). Drop in the appropriate gasket and press it down. If using the red or yellow gasket (C), be sure the flat side faces out of the retainer (A). See Fig. 11.

Screw the spray tip guard snugly onto the gun, holding it in the desired position while tightening retaining nut (A).

NEVER use a wrench to turn the plastic tip guard (J), to avoid damaging the guard.

Operation

⚠ WARNING

Keep clear of the nozzle! High pressure fluid from leaks or spray can penetrate the skin and cause extremely serious injury, including the need for amputation. The spray tip guard provides extra protection against injection, but does not prevent it! Never cut off the spray tip guard.

Be sure the spray tip handle is in the FULL SPRAY position before operating the gun. See Fig. 11.

Clearing a Clogged Spray Tip

Disengage the trigger cable(s). Engage the gun safety latch. Turn the arrow handle to the FULL CLEAN position. See Fig. 13. Release the safety latch and trigger the gun. Fluid pressure should force out the clog. Return the arrow handle to the full spray position. **If it is still clogged**, follow the **Pressure Relief Procedure** on page 7 and remove the spray tip for cleaning.

Maintenance

Change the seat and gasket when the spray tip wears out; these parts wear at about the same rate.

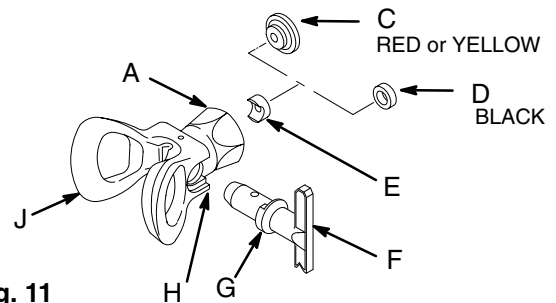

Fig. 11 0091

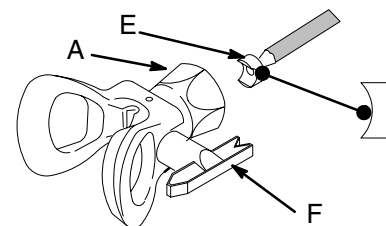

Fig. 12 0092

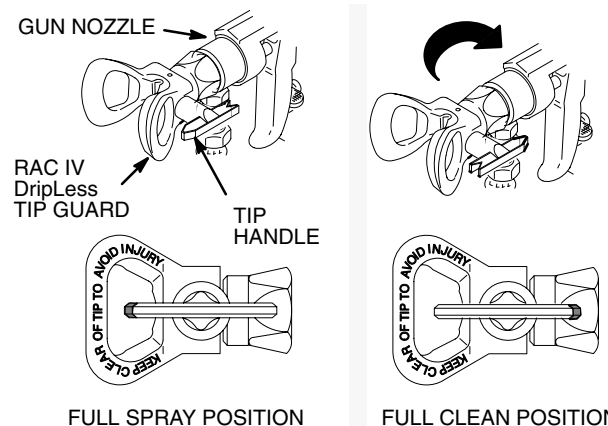

Fig. 13 0093

Spray Tip Selection

Spray Tip Application Recommendations

Application	Lineal Feet/Minute (rate at which unit is moved) Based on 4" wide line and 15 mils of paint							
	120	144	184	220	264	308	352	400
Parking Lot Lines 4" wide	217	LLT-319*†	221*	223	224			
6" wide	317	319*	321*	323	325			
Long Lines, 4-6" wide			221*	223	225	227	228	231
Curbs	417*	419*						

* Tips can be used with two guns. † Supplied with the Line Lazer.

Other Applications

Sport Court, 2" wide line	115, 117
Crosswalk, 12" wide line, 1 gun	621, 623, 625
Airport, 24" wide line, two guns	721
Stencils	417*, 419*
General Stationary Painting	517†

Fig. 14

Spray Techniques

These spray techniques discuss how to use and adjust the features of the Line Lazer. You must also consider operator technique, job site conditions and weather.

1. Use water rather than paint to practice spraying technique and positioning the guns.
2. Be sure the RAC IV Tip Guard is always parallel to the ground and the "wings" of the spray tip guard face the front and back of the unit, as shown in Fig. 15.

⚠ WARNING

To reduce the risk of a fluid injection injury, always disengage the remote trigger cable to the gun(s) and engage the gun trigger safety latch(es) before moving or adjusting the spray tip guards, guns, or gun arms. See Page 21.

3. Use the lowest pressure necessary for good atomization. High pressure may cause excessive paint buildup and overspray.
4. Start moving the Line Lazer before triggering the gun to prevent a build up of paint at the beginning of the line. Release the trigger a second before stopping the Line Lazer. Move at an even rate of speed.
5. Always check your gun adjustments on cardboard or paper before starting each job. When painting curbs, paint first in an area that is less frequently seen.
6. Keep in mind that many factors affect the straightness of a line, including uneven surfaces, potholes, rocks and other debris and a clogged or worn spray tip. See page 15 for how to clear or change a spray tip.
7. To minimize the effect of bumps on the spray pattern, keep the spray tip guard centered with the front wheel axis.

8. The spray tip size and the rate at which you move the unit affect the coating thickness. Generally, the faster you move the unit, the larger the spray tip orifice should be. The fan width of the spray tip indicates approximately how wide the line will be. See the chart in Fig. 14 for spray tip application recommendations.
9. Position the guns to suit your requirements. See the section below and pages 17 to 19.
10. Traffic paints may be formulated for air spray, airless spray or have no formulation description. Generally, air spray formulas are pre-thinned, and will work well in the Line Lazer, but there may be more overspray. Non-air spray formulas tend to deliver more lineal feet of line per gallon with less overspray, since they are less easily absorbed into the pavement.
11. If you use fast-drying traffic paint on a hot day, float compatible solvent on top of the paint to prevent skin from forming on it.

Line Width Adjustment

Several factors affect line width: vertical distance of the spray tip to the spraying surface, spray tip fan pattern, using one or two guns, paint pressure, and a worn or clogged spray tip.

The typical conditions for a 4 in. (10 cm) wide line are: 319 size Line Lazer Tip (supplied), the gun positioned one inch from the lowest vertical position, and just enough pressure to atomize the paint. Depending on the fan pattern of the spray tip, use one gun to paint 2 to 12 in. (5 to 30 cm) wide lines, and two guns to paint 12 to 24 in. (30 to 61 cm) wide lines.

To decrease line width, lower the gun (if possible) or use a tip with a narrower fan pattern.

To increase line width, raise the gun, or use a tip with a wider fan pattern, or use two guns.

Positioning the Gun Arm Assembly

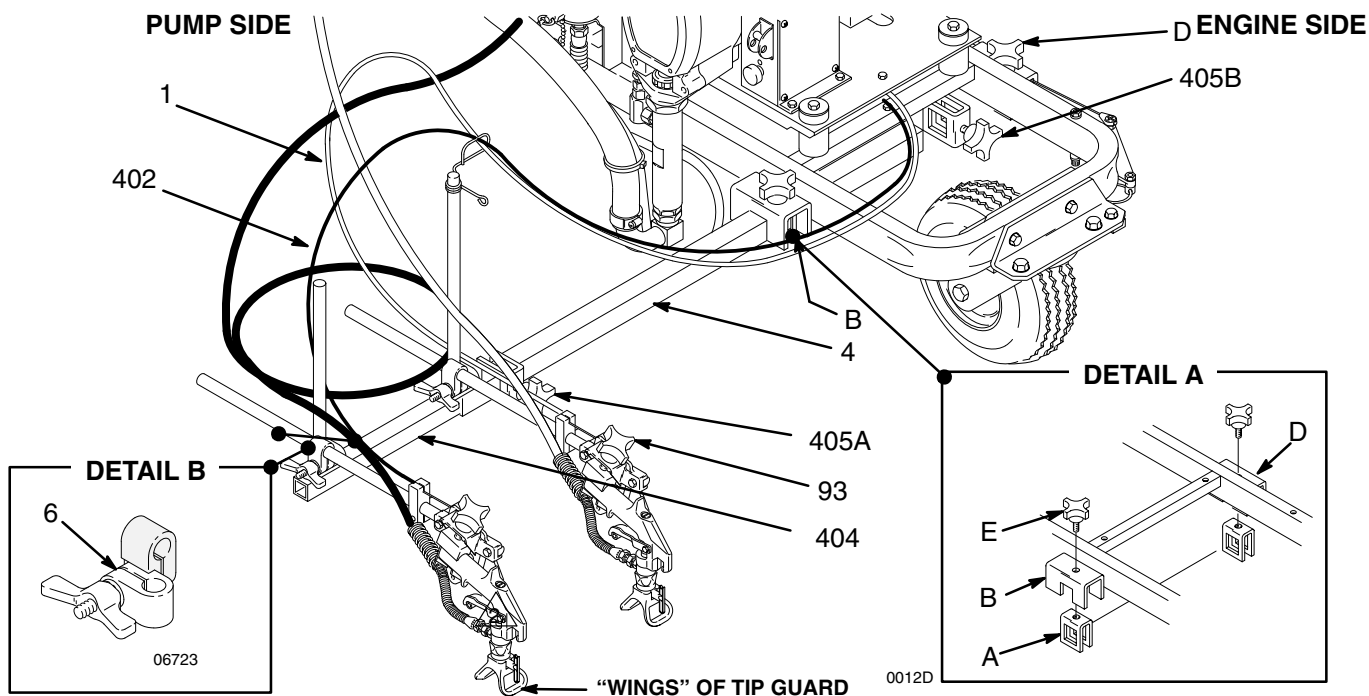

Fig. 15

NOTE: To prevent premature arm clamp (6) wear, make sure that the half of the clamp holding the gun support arm is supported by the notch in its side. See Fig. 15 DETAIL B.

The gun arms can be positioned for a variety of spraying needs. The drawings on page 19 primarily show the guns mounted on the pump side of the Linestriper. However, one or both guns may be mounted on the engine side.

Whenever You Move the Guns

CAUTION

Do not kink the cables, which could prevent them from properly triggering and untriggering the guns.

Disengage the trigger cables and engage the gun trigger safety latch first. See page 21. Do not kink the trigger cables. Pull out more of the 50 ft. hose, if necessary.

After moving the guns, reposition the spray tip guard so it is parallel to the ground and its "wings" face the front and back of the unit. Disengage the gun trigger safety latch and engage the trigger cable.

Vertical Position of the First or Second Gun

Loosen the arm clamp (6) and move the gun up or down. Tighten the clamp. Engage the trigger cable.

Horizontal Position of the First Gun

Method 1: Disengage the trigger cable. Loosen the carriage clamps (B,D) and slide the carriage bar (4) left or right, so the gun will be outside the tire path. Tighten the clamps. Engage the trigger cable.

Method 2: Disengage the trigger cable. Loosen the arm clamp (6) and rotate the gun out to the side. Tighten the bolt. Engage the trigger cable.

NOTE: Use methods 1 and 2 together to obtain the maximum distance of one gun from the unit, which is helpful when spraying around obstacles.

Horizontal Position of the Second Gun

Method 1: Disengage the trigger cable. Loosen the clamps (405A, 405B). Slide the second gun bar (404) horizontally, being sure both clamps engage the second gun bar. Tighten the clamps. Engage the trigger cable.

Method 2: Disengage the trigger cable. Loosen the arm clamp (6) and rotate the gun out to the side. Tighten the bolt. Engage the trigger cable.

NOTE: Use methods 1 and 2 together to obtain the maximum distance of 33-1/2 in. (851 mm) between the center of two guns.

Positioning the Gun Arm Assembly

Mount Guns on the Engine Side of the Cart

1. For both guns, disengage the trigger cable and engage the trigger safety latch. See page 22.
2. Loosen the gun holder knobs (93) and remove the gun. Lay the guns out of the way.
3. Remove the knobs (E) on both carriage clamps (B,D); the carriage bar (4) and extension clamps (A) will drop down. See Fig. 15 DETAIL A.
4. Lift the front tire and rotate the carriage bar 180° under the cart and to the other side of it.
5. Position the carriage bar below the carriage clamps (B,D). Align the holes in the top of the extension clamps (A) with the holes in the carriage bar clamps and install the knobs (E). See Fig. 15 DETAIL A.
6. Loosen the post/arm clamps (6) and rotate the guns forward. Retighten the clamps.

7. Install the guns. Note which gun and position on the dual gun selector each of the cables (1 and 402) goes. Route the hoses and cables to prevent kinking. Position the spray tip guards. Disengage the gun trigger safety latches. Engage the trigger cables.

Setup for Spraying Arcs

1. Disengage the trigger cable (1) and engage the gun trigger safety latch. See page 21.
2. Loosen the arm clamp (6) and rotate the arm (A) back near the rear tire and then position the arm so the spray tip guard aligns with the back axle of the unit. Retighten the clamp.
3. Extend the carriage bar (4) or second gun bar (404) so you can easily watch the line you are painting and also to avoid running over the paint line. See page 17.
4. Adjust the vertical and horizontal position of the gun.
5. Spray the arc from the outside.

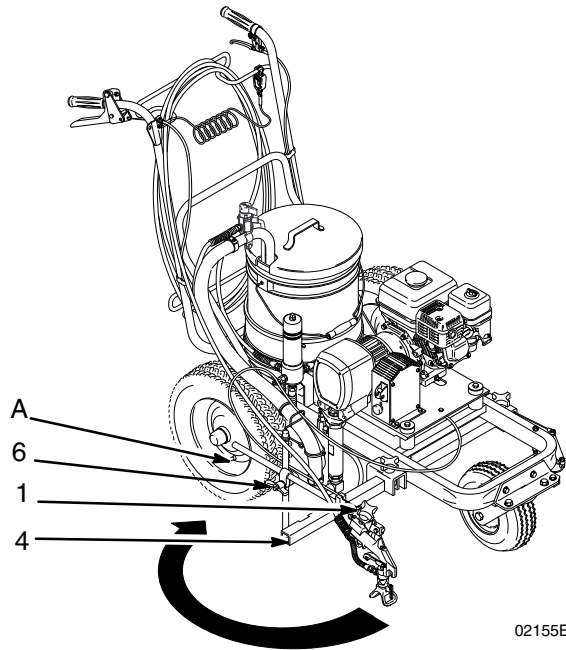

Fig. 16

Adjust Simultaneous Gun Triggering

⚠ WARNING

To reduce the risk of a fluid injection injury, always disengage the trigger cable to the gun (s) and engage the guns' trigger safety latch before moving or adjusting the guns or gun arms.

1. Align the front of the guns by adjusting the gun arms. See page 17.

2. Position the dual gun selector to trigger both guns. See page 21.
3. Start the sprayer, using water, or spray on cardboard. See page 13. Trigger the guns to see if the lines begin at the same time and place.

If one gun triggers before the other gun, reduce the cable tension of the gun that triggers first. See **Adjust the trigger cable tension** on page 22.

If one line starts in front of the other, adjust the position of the guns. See page 17.

Trigger the guns to recheck the adjustments.

Gun Arm Positions

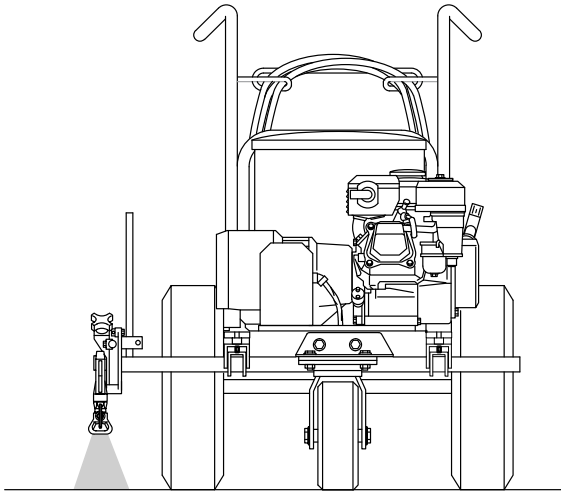

SINGLE LINE

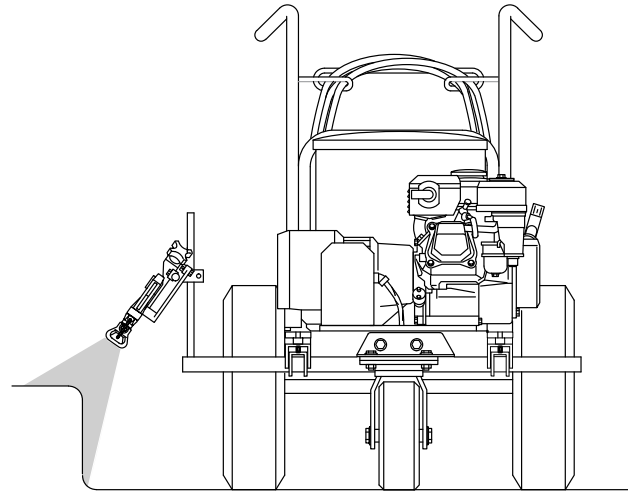

ONE GUN CURB

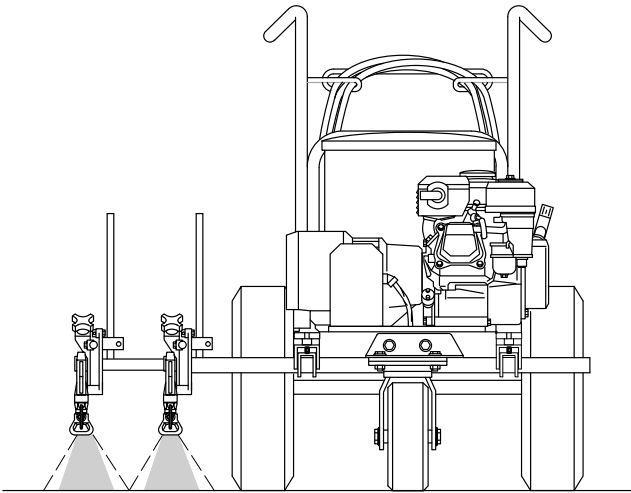

DOUBLE LINE OR SINGLE LINE UP TO 24" WIDE

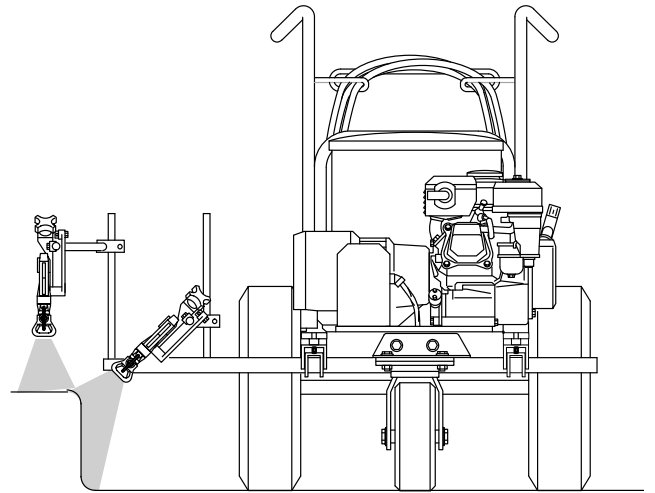

TWO GUN CURB

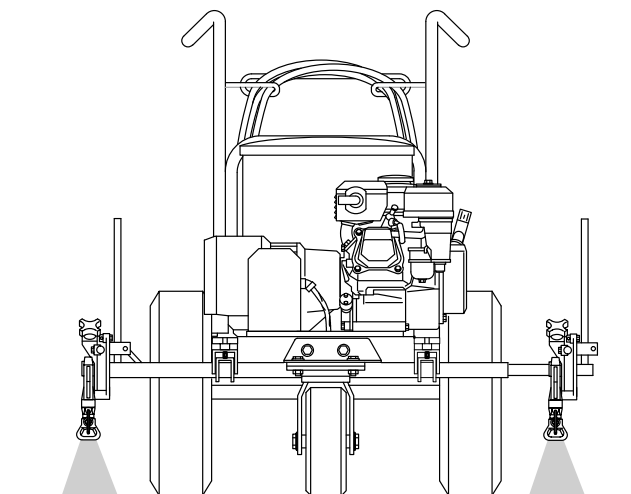

SINGLE OR DOUBLE LINE; SPRAYING AROUND OBSTACLES

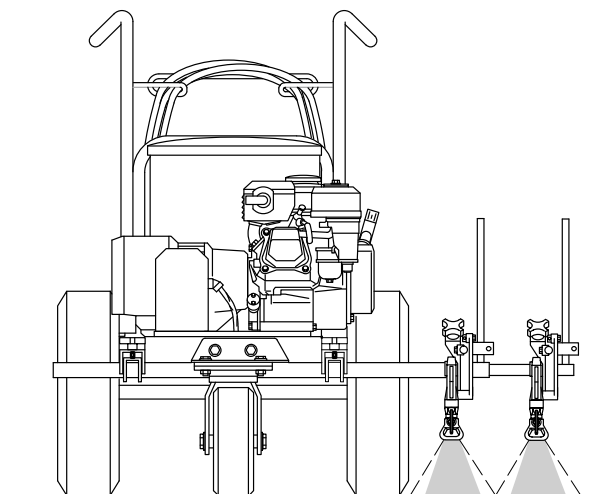

DOUBLE LINE OR SINGLE LINE UP TO 24" WIDE

0017

Caster Lever and Cable Operation

⚠ CAUTION

The AccuTrack™ caster is factory-adjusted to track in a straight line. It should not require adjustment unless it is replaced. If a line is tracking poorly, check for the following items before aligning the caster.

1. Even back tire pressure.
2. Even tension on the rear tire bearings (adjust nuts (10) as needed.) See page 44.
3. Even tightness of the caster screws (F). See Fig. 18.
4. Uneven painting surface.
5. Operator technique.

Operation

The normal operating mode of the AccuTrack™ caster is locked in the straight forward position.

1. For a free moving caster: Squeeze and hold the caster lever (22).
2. To lock the caster in the free moving position, squeeze the trigger, push in and hold the the button (A) and release the trigger. See Fig. 17.
3. To return to the normal mode, squeeze and release the caster lever and move the Line Lazer forward to lock the caster in the straight position.

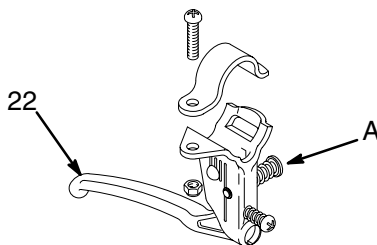

Fig. 17 0018

Maintenance See Fig. 18

Paint builds up on the caster triggering mechanism. To keep it operating properly, use a grease gun at the grease zerks (32A, 32B) to flush out the buildup – two to four times a month, depending on use.

Caster Tire Replacement See Fig. 18.

Remove the setscrews (F) from the caster fork (E). Remove screw (G) and the tire (114a). Install the new tire and the setscrews (F). Tighten the setscrews equally so the tire has no play in it, but turns freely.

Caster Cable Tension Adjustment See Fig. 18.

1. Loosen the nut (A) located just outside the carriage clamp (B).
2. With the pin (D) fully engaged in the caster fork (E), pull back on the cable (2) to increase the cable tension, or push it forward to reduce the tension. Finger tighten the nut (H). Tighten the nut (A) firmly.

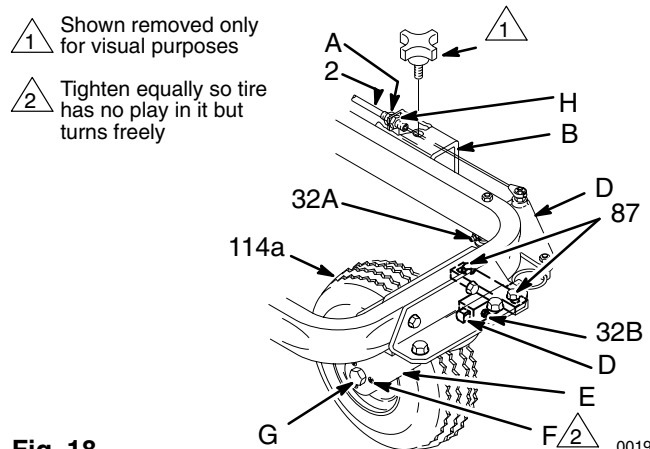

Fig. 18 0019

Caster Alignment

Do this adjustment only if the caster or tire is replaced, or if no other solutions to poor tracking are found.

1. Loosen the two capscrews (87). Grasp the tire and visually align it. Tighten the capscrews evenly. Move the unit forward. If the caster appears straight, start the unit (use water) and spray along a true straight line. Continue adjusting as necessary. See Fig. 18.

How To Mount the Gun

1. Relieve pressure. See page 7.
2. Disengage the trigger cable. See page 21. Engage the gun's trigger safety latch (B).
3. Loosen the gun holder knob (93).
4. Position the gun so the gun trigger is resting on the remote trigger lever (A).
5. Be sure that the gun is mounted straight and then tighten the knob (93) firmly.
6. Disengage the gun safety latch. Engage the remote trigger cable. See page 21.

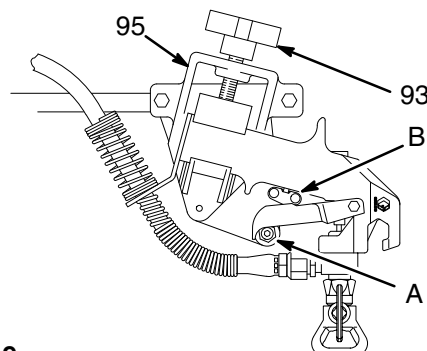
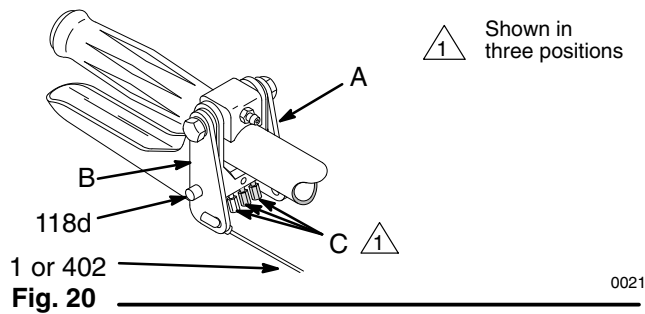

Fig. 19 0020B

Gun Cable & Dual Gun Selector Operation



How the Dual Gun Selector Works See Fig. 20.

The gun is remotely triggered with the dual gun selector on the right handlebar. The gun is mounted in the holder so its trigger rests on a trigger lever which is connected to the dual gun selector by a trigger cable.

The main gun cable is black. In a two-gun operation, the second gun cable (402) is black with a light red cover at each end. Use the color coding to determine how each trigger cable is routed to the dual gun selector.

CAUTION

Always note to which gun and position on the dual gun selector (C) each of the cables goes so that the correct gun is triggered.

To trigger the main gun only, move the selector (C) left until the spool (118d) protrudes through the plate (B) and disengages from the other plate (A).

To trigger the optional second gun only, move the selector (C) right until the spool protrudes through the plate (A) and disengages from the other plate (B).

To trigger both guns, center the selector (C).

How to Release the Dual Gun Selector Cable

WARNING

The gun is remotely triggered with a dual gun selector on the handle bar.

To reduce the risk of an injection injury due to remotely triggering the gun by accident, always disengage the trigger cable from the block before handling the gun. See Fig. 21 DETAIL A. **The gun will trigger briefly when releasing the cable!** Before you remove the gun from the holder, engage the gun's trigger safety latch.

1. To disengage the cable, grasp the cable (1 or 402) just behind the block (48). Pull the cable back about 1/2 inch (13 mm) and then up and out of the block. **The gun will trigger briefly!** See Fig. 21.
2. To engage the cable, slide the cable (1) into the block (48), making sure the end of the cable jacket seats firmly in the seat of the block. **The gun will trigger briefly!** See Fig. 21.

CAUTION

Keep the seat in the gun cable block (48) and the end of the cable jacket clean at all times to be sure the cable functions properly.

CAUTION

A loose cable prevents the gun from being fully triggered causing premature wear of the gun needle. A tight cable prevents the gun from being fully untriggered resulting in dripping and premature tip wear. Follow **Trigger cable tension adjustment** on page 22.

Trigger Cable & Dual Gun Selector Operation

Trigger Cable Tension Adjustment See Fig. 21

1. Relieve pressure. See page 7.
2. Be sure the gun is properly mounted in the holder as instructed on page 20.
3. Pull the actuator lever (94) forward and hold it. Lift up on the gun trigger (A) until there is slight resistance. Visually check to see if there is about 1/32 to 1/16 in. (1–2 mm) gap between the trigger lever (B) and where the gun trigger touches the bar.
4. To adjust the tension, loosen the screw (C) in the block (48). Slide the block forward to increase the gap and backward to decrease the gap. Tighten the screw.
5. Recheck the gap and adjust as needed.

CAUTION

Do not allow the cable (402) to rub against the outside edges of the slot (H) in the block (48), to prevent premature wear of the cable. Rotate the block slightly to eliminate rubbing. See Fig. 21 DETAIL A.

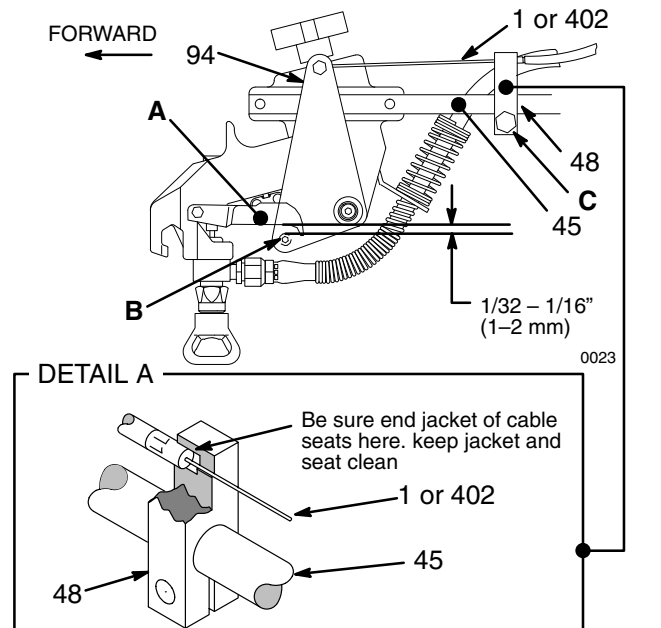

Maintenance

WARNING

To reduce the risk of serious injury always follow the **Pressure Relief Procedure** on page 7, before checking, adjusting, cleaning, or shutting down the LineLazer.

CAUTION

For detailed engine maintenance and specifications, refer to the separate HONDA engine manual.

Daily: Check the engine oil level and fill as necessary.

Daily: Check and fill the gas tank.

After the first 20 hours of operation and each 100 hours thereafter: Change the oil.

Weekly: Remove the air filter cover and clean the element. In very dusty environments, check the filter daily. Replace the element as needed. Replacement elements can be purchased from your local HONDA dealer.

Weekly: Check the level of the TSL in the displacement pump packing nut. Fill the nut, if necessary. Keep TSL in the nut to help lubricate the pump packings. See page 8.

Weekly: Use a grease gun to grease the zerks (32) on this unit. The grease purges pivot areas of paint buildup. See Fig. 22.

Spark plug: Use only a (NGK) BP6ES or BPR6ES plug. Gap the plug to 0.025 to 0.030 in. (0.7 to 0.8 mm). Always use a spark plug wrench.

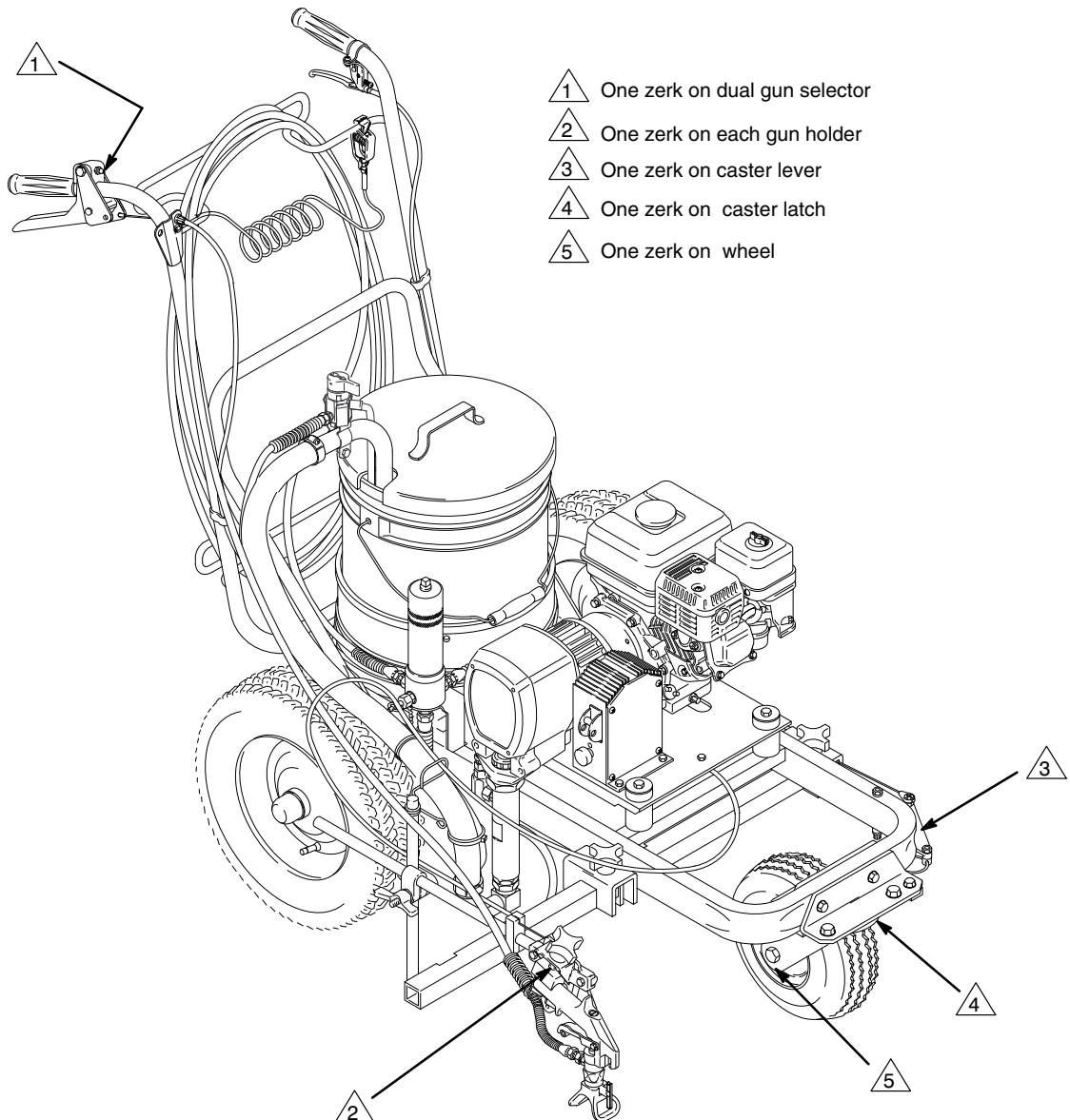

Fig. 22

02154C

Troubleshooting

WARNING

To reduce the risk of serious injury whenever you are instructed to relieve pressure, always follow the **Pressure Relief Procedure** on page 7.

Check everything in the chart before disassembling the sprayer.

PROBLEM	CAUSE	SOLUTION
Engine/sprayer won't start	Engine switch not on	Turn on engine switch.
	Out of gas	Refill gas tank.
	Engine oil level low	Try starting engine. If light on rear of engine glows, replenish oil.
	Spark plug cable disconnected or spark plug damaged	Connect cable on top of engine or replace spark plug.
	Water frozen in pressure control	Return pressure control to authorized Graco dealer for repair.
Engine won't "fire"	Oil seepage into combustion chamber	Remove spark plug. Pull starter rope 3 or 4 times. Clean and replace plug. Try to start. Keep sprayer upright to avoid oil seepage.
Engine operates, but displacement pump doesn't	Pressure control switch turned OFF	Turn on pressure control switch.
	Pressure setting too low	Increase pressure.
	Displacement pump outlet filter dirty	Clean filter.
	Tip or tip filter clogged	Clean tip or tip filter.
	Displacement pump rod seized by dry paint	Service pump. See page 26.
	Connecting rod worn or damaged	Replace connecting rod. See page 30.
	Drive housing worn or damaged	Replace drive housing. See page 31.
	Electrical power not energizing field	Check wiring connections. See page 37. With pressure control switch ON and pressure turned to MAXIMUM, use a test light to check continuity across black and white wires from pressure control. Have pressure control checked by authorized Graco dealer.
	Clutch worn or damaged	Service clutch. See page 34.
Pinion assembly worn or damaged	Service pinion assembly. See page 32.	
Engine starts but dies	Oil level drops below oil sensor	Add oil.
Displacement pump output low on upstroke	Pump inlet screen clogged	Clean screen.
	Piston ball check not seating	Service piston ball check. See page 26.
	Piston packings worn or damaged	Replace packings. See page 26.
	Sleeve gasket in displacement pump worn or damaged	Replace sleeve gasket. See page 26.

Troubleshooting

PROBLEM	CAUSE	SOLUTION
Displacement pump output low on downstroke or both strokes	Pump inlet screen clogged	Clean screen.
	Pressure setting too low	Increase pressure. See Startup , Step 14, page 13.
	Dirty outlet filter, tip filter or tip	Clean filters and/or tips.
	Piston packings worn or damaged	Replace packings. See page 26.
	Intake valve ball check not seating properly	Clean and service intake valve. See page 26.
	Engine RPM too low	Increase throttle setting. See Startup , Steps 5b and 14, page 13.
	Clutch worn or damaged	Replace clutch. See page 34.
	Partially clogged suction tube assembly	Remove and clean suction tube. During normal flushing remove and clean the suction tube assembly separately to prevent further clogging.
	Large pressure drop in hose	Use larger diameter hose.
Paint leaks into wet-cup	Loose wet-cup	Tighten wet-cup just enough to stop leakage.
	Throat packings worn or damaged	Replace packings. See page 26.
	Displacement rod worn or damaged	Replace displacement rod. See page 26.
Spitting from gun	Air in fluid pump or hose	Check for loose connections at pump intake and tighten. Then prime the pump. See Startup , page 13.
	Tip partially clogged	Clear tip clog. See page 15.
	Fluid supply is low or empty	Refill and prime the pump. See Startup , page 13. Check fluid supply often to prevent running the pump dry.
	Dried paint particles from a poorly cleaned suction tube assembly	Remove and clean suction tube. During normal flushing remove and clean the suction tube assembly separately to prevent further clogging.

Displacement Pump

⚠ WARNING

To reduce the risk of serious injury whenever you are instructed to relieve pressure, always follow the **Pressure Relief Procedure** on page 7.

Removing the Pump See Fig. 23.

1. Flush the pump. Relieve pressure.
2. Hold the intake valve (223) with a wrench and unscrew the suction tube swivel union (53). Unscrew the hose (133).
3. Push the retaining spring (75) up. Push the pin (71) out the rear.
4. Loosen the locknut (137). Unscrew the pump.

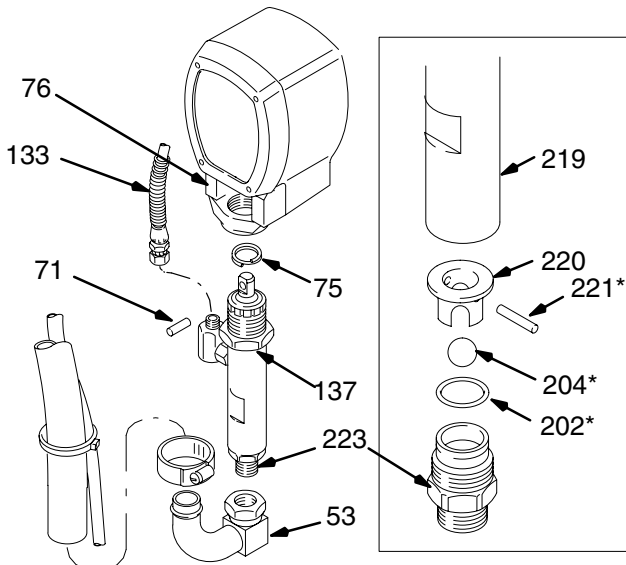

Fig. 23

Disassembling the Pump

1. Unscrew the intake valve (223) and remove all parts. See Fig. 23.
2. Remove the plug (205). Unscrew the packing nut (216). See Fig. 24.

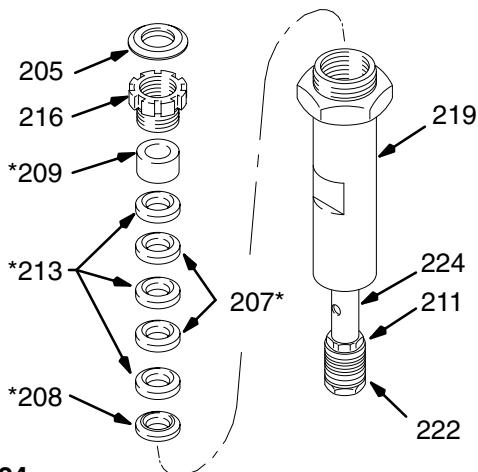

Fig. 24

0026

3. Tap the piston rod (224) down and then pull it out the bottom of the cylinder (219). See Fig. 24.
4. Remove the glands (*209, *208*) and v-packings (*207*, *213**) from the throat. See Fig. 24.
5. Clamp the flats of the piston rod (224) in a vise. Loosen the piston (222). Unscrew the nut (211) from the piston. Remove the glands (*210*, *214**) and packings (*212*, *206*, *203**) from the piston. See Fig. 24.

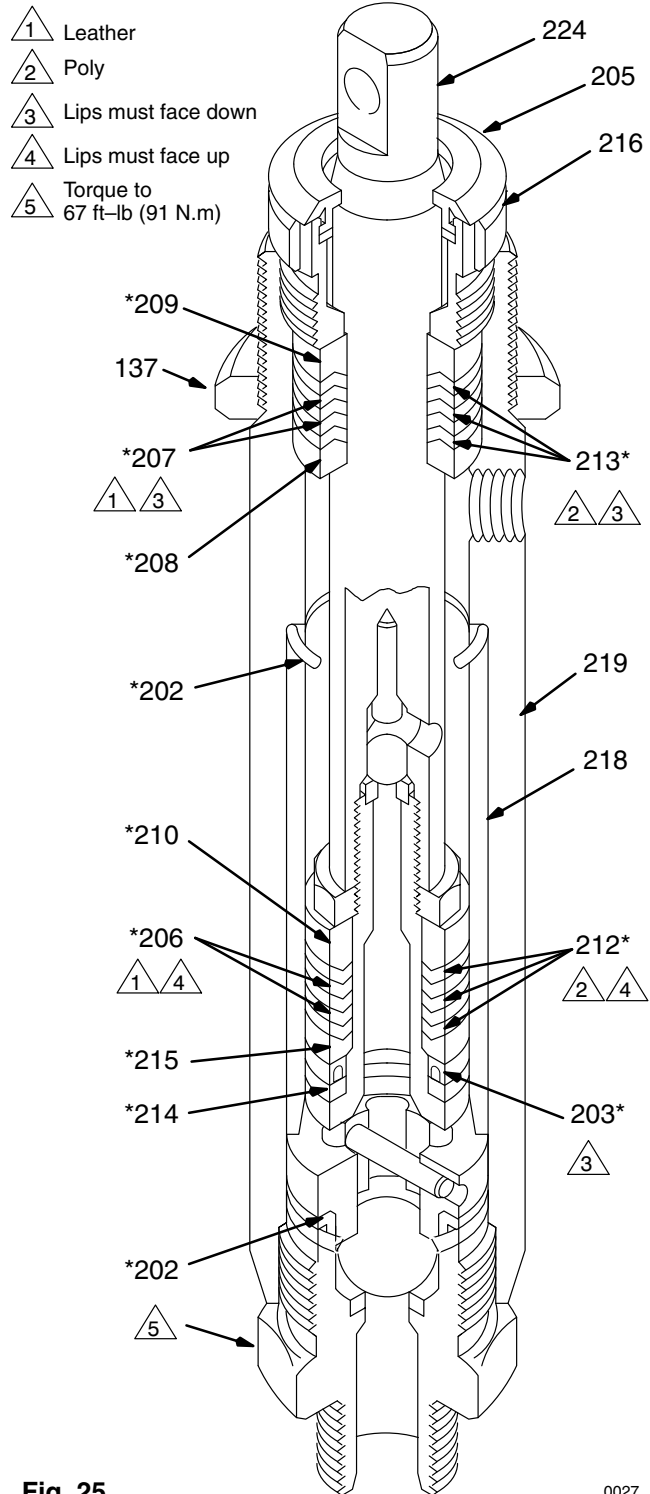

Fig. 25

0027

Displacement Pump

⚠ WARNING

To reduce the risk of serious injury from pump rupture, use only tool 224-788 to remove the sleeve. If the sleeve is stuck, send the cylinder to your Graco distributor for removal.

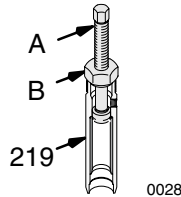

Fig. 26

- Remove the sleeve when servicing the pump. Use special tool, Part No. 224-787 only. Screw the nut (B) into the cylinder (219). Screw down the rod (A) to push the sleeve out. See Fig. 26.

Assembling the Pump

NOTE: Repair k'Kit 222-588 is available. For the best results, use all the parts in this kit. The kit includes parts marked with an asterisk, for example (201*).

NOTE: Soak the packings in oil, and coat the rod and inside of the cylinder with oil.

NOTE: Alternate leather and plastic packings. Be sure the lips of the v-packings face the direction shown. Incorrect installation damages the packings and results in pump leakage.

- Check the piston rod (224) and the inside of the sleeve (218) for scoring or scratches. If these parts are damaged, new packings will not seal properly.
- Stack the piston packings onto the piston (222) as shown in Fig. 25.
- Tighten the piston nut (211) onto the piston to 10.5 in-lb (1.2 N.m.) to seat the packings, and then back off and finger tighten.

1 Apply one drop of sealant to these threads

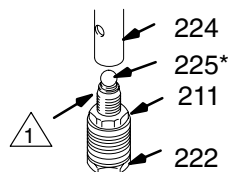

Fig. 27

NOTE; Note and maintain the alignment of the piston (222) to the nut (211) through Steps 4, 5 and 6.

- Apply **ONE** drop of adhesive, supplied with the repair kit, to the piston threads. Place the ball (225*) on the piston. Hand tighten the piston into the rod (224) just until the nut (211) contacts the rod. Place the flats of the rod in a vise.
- Tighten the nut (211) onto the rod (224) to 19 ft-lb (26 N.m). Use two wrenches to maintain the alignment as mentioned in Step 3.

- Stack the throat packings into the top of the cylinder (219). Install the packing nut (216) loosely.

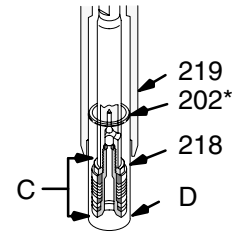

Fig. 28

- Insert the piston rod assembly (C) into the **top of the sleeve (218)**. Install the gasket (202*) on the sleeve. Slide the sleeve assembly into the **bottom of the cylinder (219)**. Note that the tapered end (D) of the sleeve is at the bottom. See Fig. 28.
- Assemble and install the intake valve. Use a **new** gasket (202*). Tighten the valve to 67 ft-lb (91 N.m). See Fig. 23.

Installing the Pump

- See Fig. 23 and 29.
- Screw the pump 3/4 of the way into the bearing housing (76). Hold the pin (71) up to the pin hole in the connecting rod (79) and continue screwing in the pump until the pin slides easily into the hole.
 - Align the top threads of the pump cylinder flush with the face (E) of the bearing housing and so the outlet nipple (15) faces the rear of the unit.
 - Push the retaining spring (75) completely into the connecting rod groove. Tighten the locknut (137) very tight - 90 ft-lb (122 N.m), to prevent it loosening and damaging the threads of the bearing housing.

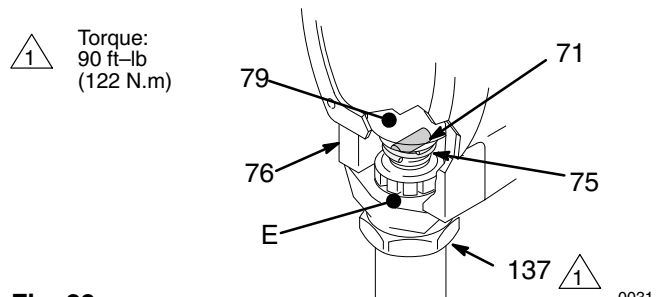

Fig. 29

⚠ WARNING

Be sure the retaining spring (75) is firmly in the groove all the way around, to prevent the pin (71) from working loose due to vibration.

If the pin works loose, it or other parts could break off due to the force of the pump action. These parts could be projected through the air and result in serious injury or property damage, including damage to the connecting rod and bearing housing.

- Tighten the packing nut (216) just enough to stop leakage. Fill the nut 1/3 full with Graco TSL, and assemble the remaining parts.

Pressure Control

⚠ WARNING

To reduce the risk of serious injury whenever you are instructed to relieve pressure, always follow the **Pressure Relief Procedure** on page 7.

1. Disconnect both hoses (133) at the pressure control swivel unions (108). Note the original location of each hose to be sure you reassemble them correctly at the end of this procedure. See Fig. 30.
2. Working under the engine mounting plate of the cart, disconnect the pressure control wires at **A**. Remove the four nuts (40) and related hardware from the capscrews (91 & 87).
3. Remove the pressure control covers (89). See Fig. 30.
4. Disconnect the red, black and white wires from the rectifier (307) which are sheathed with the conductor (309). Unscrew the connector (313) from the pressure control, pulling the conductor and wires out with it. See Fig. 31.
5. Use a wrench to hold the hex of the adapters (C) while removing the swivel unions (108). See Fig. 31.

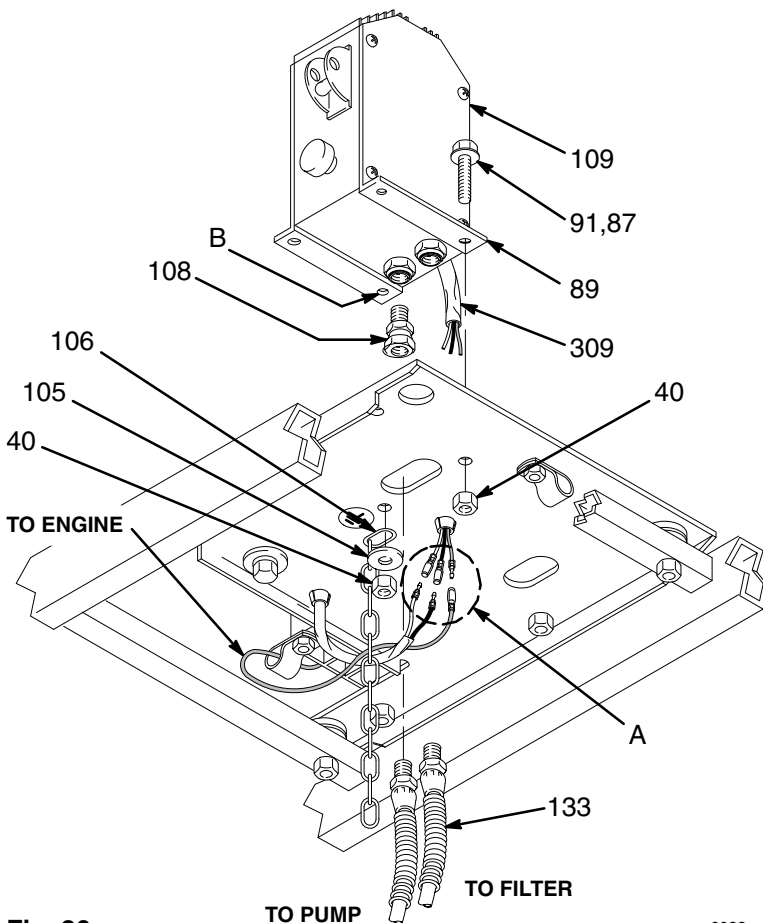

Fig. 30

0032

⚠ WARNING

To reduce the risk of electric shock, be sure all grounding features of the pressure control are properly assembled:

- Ground wire (308) connected in pressure control.
 - Serrated flange capscrews to mount the pressure control to the cart.
 - Grounding chain (106) connected by the long pressure control mounting capscrew (87).
6. Reassemble the pressure control in the reverse order. Use the long pressure control mounting screw (87) in hole **B**. From below the mounting plate (25) assemble the grounding chain (106), washer (105) and nut (40) to the screw. See Fig. 30.
 7. Perform the **Pressure Control Adjustment** on page 29 before regular operation of the sprayer.

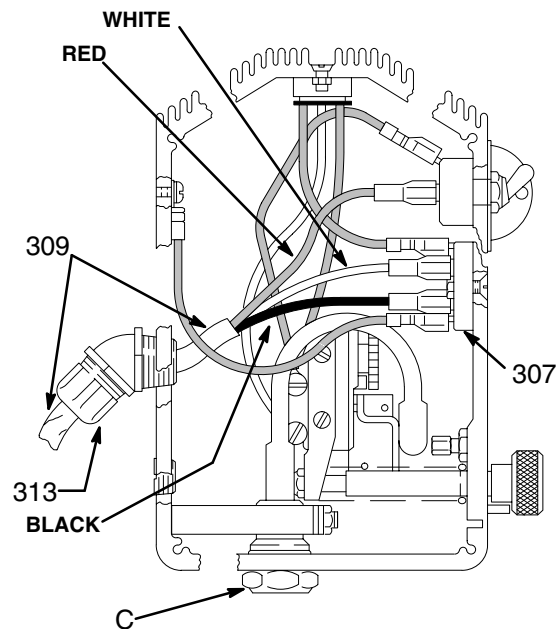

RECTIFIER (307) CONNECTIONS
RED BLACK

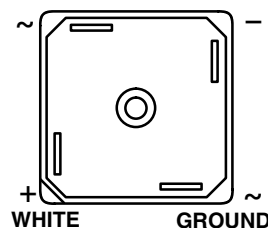

Fig. 31

0034

Pressure Control Adjustment

⚠ WARNING

Use extreme caution when performing this calibration procedure to reduce the risk of a fluid injection injury or other serious bodily injury, which can result from component rupture, electric shock, fire, explosion or moving parts.

This procedure sets the sprayer to 2600–3000 psi (180–207 bar , 18.0–20.7 MPa) Maximum Working Pressure.

Perform this procedure whenever the pressure control assembly is removed and reinstalled, or replaced, to be sure the sprayer is properly calibrated.

Improper calibration can cause the sprayer to over-pressurize and result in component rupture, fire or explosion.

It may also prevent the sprayer from obtaining the maximum working pressure, resulting in poor sprayer performance.

NEVER attempt to increase the fluid outlet pressure by performing these calibrations in any other way. Never Exceed 3000 Psi (207 Bar , 20.7 MPa) Maximum Working Pressure. Normal operation of the sprayer at higher pressures could result in component rupture, fire or explosion.

ALWAYS use a new 50 foot (15.2 m) spray hose, rated for at least 3000 psi (207 bar , 20.7 MPa) Maximum Working Pressure, when performing this procedure. A used, under-rated hose could develop a high pressure leak or rupture.

Service Tools Needed:

- New 50 foot (15.2 m), 3000 psi (210 bar, 21.0 MPa), flexible nylon airless spray hose, Part No. 223–541
- 0–5000 psi (0–345 bar, 34.5 MPa) fluid-filled pressure gauge, Part No. 102–814
- New spray tip, size 0.025 to 0.029
- 3/8 in. ignition wrench or nut driver
- 5 gallon pail of water or mineral spirits
- Swivel, 156–823
- Nipple, 162–453
- Tee, 104–984

Set Up

1. Follow the **Pressure Relief Procedure Warning** on page 7.
2. Set up the system as shown in Fig. 32.

Set the Dead Band (Pressure Differential)

1. Remove the pressure control cover.

NOTE: Do not alter this adjustment if the wheel is already set as shown in Fig. 33.

2. Set the white differential wheel (A) on the micro-switch. Turn the wheel so the letter **F** is concealed behind the switch and the letter **E** is the first letter seen.

Pressure Up

1. Start the sprayer and prime it.
2. Adjust the pressure to 2600 psi (180 bar, 18.0 MPa).
3. Shut off the engine. If the pressure drops after the engine is shut off, replace the pump packings before proceeding. See page 26.

Adjust the Pressure See Fig. 34.

1. Remove the plug (320) in the bottom of the control.
2. Turn and hold the pressure control knob (B) at the maximum pressure.
3. Engage the nut (C): Insert the nut driver through the pressure control hole (D), or use an ignition wrench inserted from the front of the pressure control.

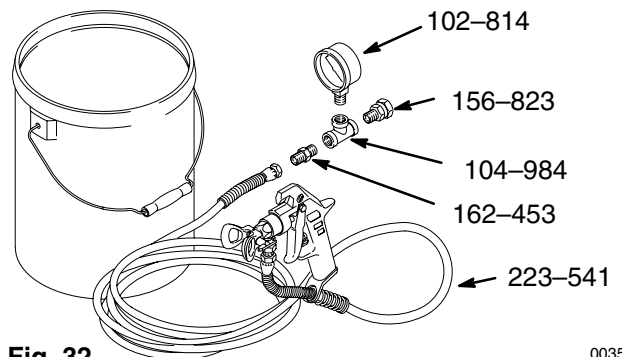

Fig. 32

0035

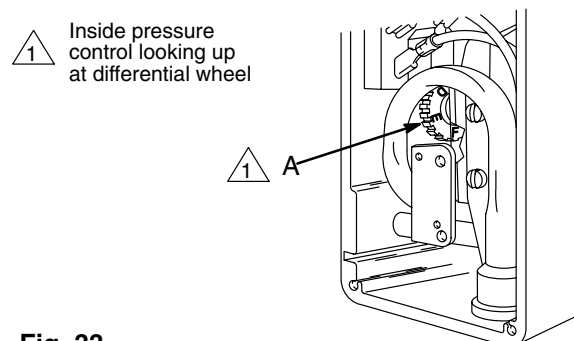

Fig. 33

0036

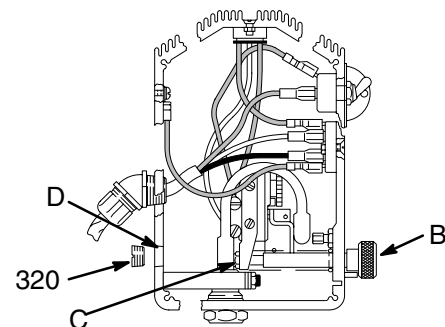

Fig. 34

0037

- a. Loosen the nut just until you hear a click. Stop.
 - b. Slowly tighten the nut just until another click is heard. Stop.
4. Replace the plug (320) and the pressure control cover.

Bearing Housing and Connecting Rod

⚠ WARNING

To reduce the risk of serious injury whenever you are instructed to relieve pressure, always follow the **Pressure Relief Procedure** on page 7.

NOTE: Steps 1 to 10 refer to Fig. 35.

1. Refer to **Removing the Pump** on page 26.
2. Remove the four screws (81) and lockwashers (46) from the bearing housing (76).
3. While pulling the connecting rod assembly (79) with one hand, lightly tap the lower rear of the bearing housing (76) with a plastic mallet to loosen it from the drive housing (77). Pull the bearing housing and the connecting rod assembly off the drive housing.
4. Inspect the crank (A) for excessive wear and replace parts as needed.
5. Evenly lubricate the inside of the bronze bearing (D) in the bearing housing (76), and the inside of the connecting rod link (C), with high-quality motor oil. Liberally pack the roller bearing (B) in the connecting rod assembly (79) with bearing grease (77d), supplied.
6. Assemble the connecting rod (79) and bearing housing (76).
7. Clean the mating surfaces of the bearing and drive housings.
8. Align the connecting rod with the crank (A) and carefully align the locating pins (E) in the drive housing (77) with the holes in the bearing housing (76). Push the bearing housing onto the drive housing or tap it into place with a plastic mallet.

⚠ CAUTION

Do not use the bearing housing screw (81) to align or seat the bearing housing with the drive housing. These parts must be aligned using the locating pins (E) to help avoid premature bearing wear.

9. Install the screws (81) and lockwashers (46) on the bearing housing. Tighten the screws evenly to 175 in-lb (20 N.m).
10. Refer to **Installing the pump** on page 27.

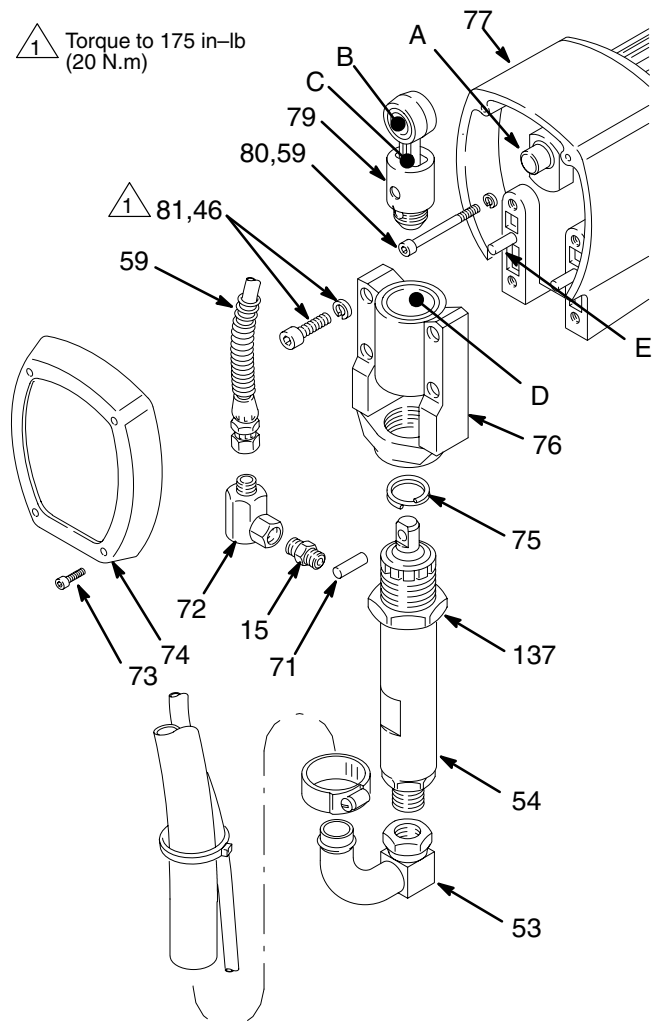

Fig. 35

Drive Housing

⚠ WARNING

To reduce the risk of serious injury whenever you are instructed to relieve pressure, always follow the **Pressure Relief Procedure** on page 7.

NOTE: Refer to Fig. 36 for this procedure.

1. Remove the front cover (74).
2. Disconnect the pump outlet hose (133).
3. Remove the four screws (81) and lockwashers (46) from the bearing housing (76).
4. Lightly tap the back of the bearing housing (76) with a plastic mallet. Pull the pump, bearing housing and connecting rod away from the drive housing as one assembly.
5. Remove the two bearing housing screws (80) and lockwashers (59). Remove the four pinion housing screws (67) and lockwashers (59).
6. Lightly tap around the drive housing (77) with a plastic mallet to loosen it from the pinion housing (138p).

⚠ CAUTION

Do not drop the gear cluster (78) when removing the drive housing (77). The gear cluster is easily damaged. The gear may stay engaged in either the drive housing or the pinion housing.

Do not lose the thrust balls (77c and 138k) located at each end of the gear cluster. The balls, which are heavily covered with grease, usually stay in the shaft recesses, but they could be dislodged. If they are caught between the gears and not removed, the balls will seriously damage the drive housing. If the balls are not in place, the bearings will wear prematurely.

7. Liberally apply bearing grease (77d, supplied) to the gear cluster (78). Be sure the thrust balls (77c and 138k) are in place.
8. Place the bronze colored washer (77a) and then the silver-colored washer (77b) on the shaft protruding from the big bearing of the drive housing (77). Align the gears and push the new drive housing straight onto the pinion housing and locating pins (B).
9. Starting at Step 5, work backwards to reassemble the sprayer. Or, move ahead to the next section in this manual if further service is needed.

1 ⚠ Torque to 175 in-lb (20 N.m)

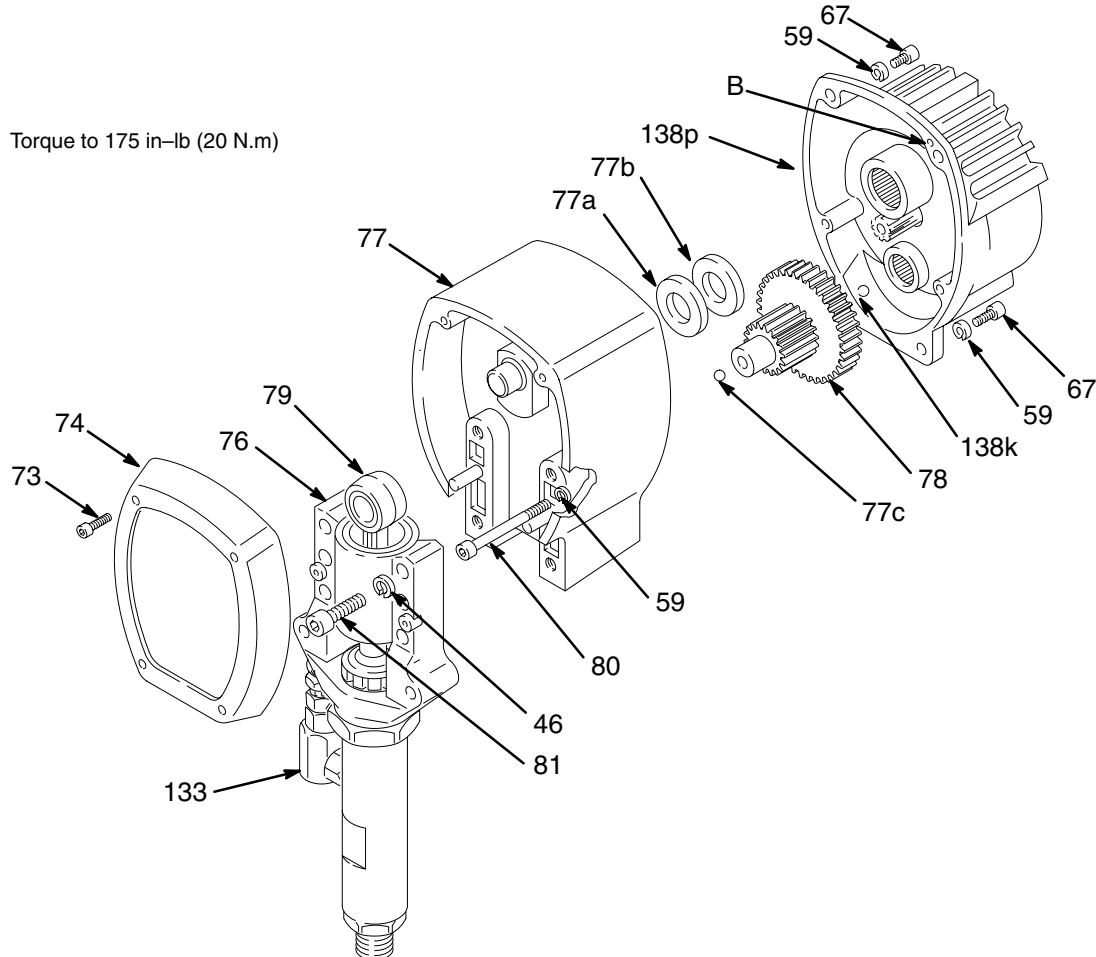

Fig. 36

0039A

Pinion, Clutch, Clamp, Field, & Engine

Disassembling these parts can start from the pinion housing or from the clutch, if no pinion service is needed.

If starting from the pinion housing, first follow Steps 1 to 6 of **DRIVE HOUSING**, on page 31, and then continue with the procedure below.

If starting from the clutch, see page 34.

Pinion Housing

Removing the Pinion Housing

⚠ WARNING

To reduce the risk of serious injury whenever you are instructed to relieve pressure, always follow the **Pressure Relief Procedure** on page 7.

NOTE: Refer to Fig. 37 for Steps 1 to 3.

1. Remove the two bottom screws (67) first, and then remove the top three screws (67).
2. Pull the pinion housing (138p) away from the clutch housing (61). The armature (55a) will come with it.
3. Pull out the armature (55a).

⚠ CAUTION

Do not lose the thrust ball (138k). Refer to the **CAUTION** on page 31 for more information.

NOTE: To disassemble the pinion, continue with **Repairing the Pinion**, below. To disassemble more of the sprayer, go to page 34. To reassemble the sprayer from this point, skip ahead to **Reassembly**, page 40, Step 8.

Repairing the Pinion

NOTE: A hydraulic press is required for disassembly and reassembly if you purchase the pinion parts individually. If you do not have such a press, use Repair Kit No. 223-189, which includes the shaft and bearings pre-assembled and lubricated.

NOTE: Refer to Fig. 38 except where noted.

If using Repair Kit 221-032, follow steps 1 to 5 below.

1. Remove the small ring (138e) from the hub (138f) and the large ring (138m) from the bearing recess of the pinion housing (138p).

2. Push on the front of the shaft (138b) to force the bearing and hub assembly out of the housing (138p).
3. Install the new shaft assembly (138a), pushing it to the shoulder of the pinion housing (138p).
4. Install the rings (138e and 138m).
5. Skip ahead to **Reassembly**, page 40, Step 7, or continue on page 34.

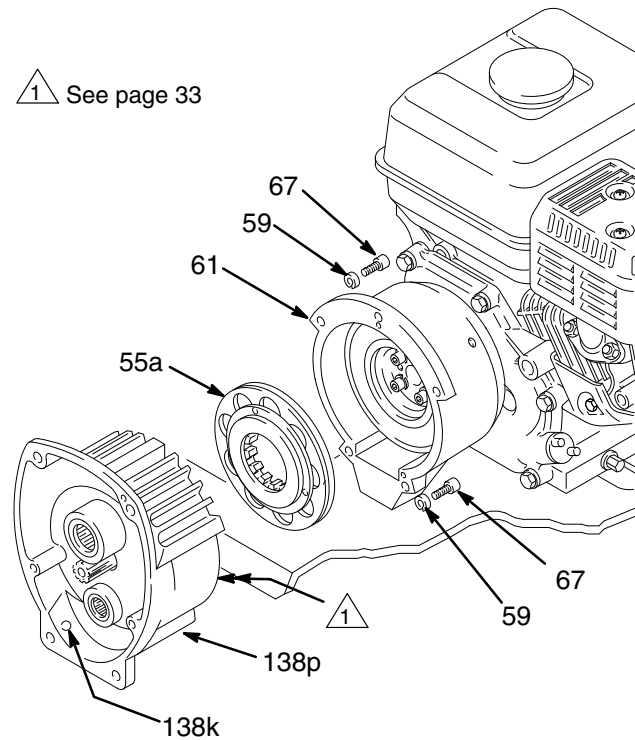

Fig. 37

0040

Pinion Housing

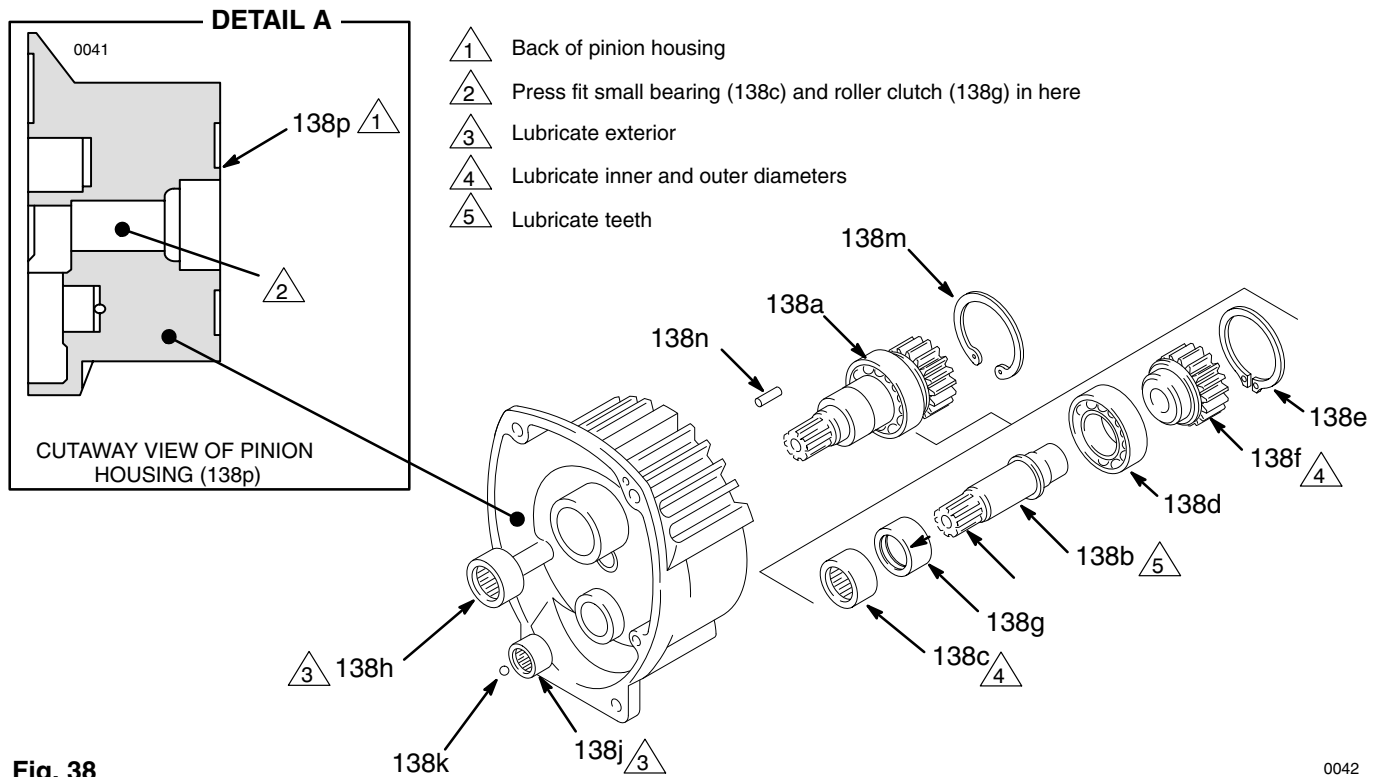

Fig. 38

If you purchased parts separately, use the following instructions. Disassemble only as far as needed for the parts being replaced.

NOTE: The old bearings (138c and 138d) will be damaged when removed. Have extra ones on hand if you need to remove them for any reason.

1. Remove the small ring (138e) from the hub (138j).
2. Remove the snap ring (138m) from the bearing recess of the pinion housing (138p).
3. Push on the front of the shaft (138b) to force the bearing and hub assembly out of the housing (138p)

4. **Using a hydraulic press**, place pieces of steel bar stock on the inner race of the large bearing (138d) and press the shaft through the hub and bearing. See Fig. 38.
5. Apply lubricant to the parts as shown in Fig. 38.

CAUTION

The arrow on the roller clutch (138g) must point toward the small bearing (138c) for the shaft (138b) to rotate in the right direction.

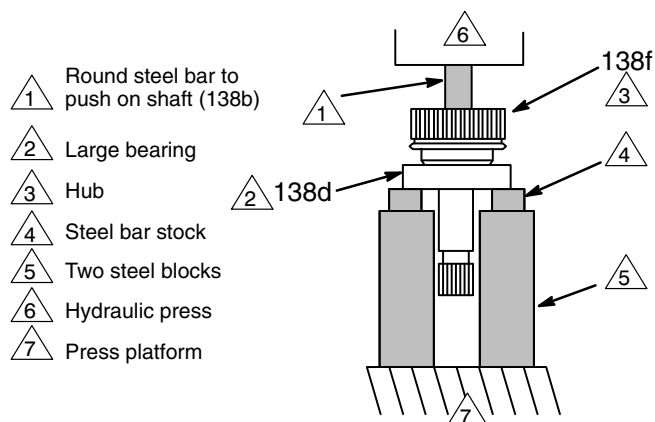

Fig. 39

PLACEMENT OF STEEL BLOCKS AND BAR STOCK WHEN PRESSING OFF LARGE BEARING

6. Press fit the following parts:
 - Large bearing (138d) to the shoulder of the shaft (138b).
 - Small bearing (138c) to the shoulder of the shaft (138b).
 - Hub (1138f) onto the shaft (138b) all the way to the large bearing (138d).
7. Install the shaft assembly (138a), pushing it to the shoulder of the housing (138p).
8. Install the rings (138e and 138m).
9. Skip ahead to **Reassembly**, page 40, Step 7, or continue on the next page.



Clutch

NOTE: The clutch assembly (55) includes the armature (55a) and rotor (55b). The armature and rotor must be replaced together so they wear evenly.

NOTE: If the pinion assembly (138) is not yet separated from the clutch housing, follow Steps 1 to 4. Otherwise, start at Step 5.

1. Follow the **Pressure Relief Procedure Warning** on page 7.
2. Disconnect the hose (133) from the displacement pump.
3. Remove the bottom two screws (67) from the clutch housing (61) and then remove the remaining three screws (67).

4. Tap lightly on the back of the drive housing (77) with a plastic mallet to loosen the assembly (D) from the clutch housing (61). Pull the assembly away; the armature (55a) will come with it.
5. Remove the armature from the pinion shaft.
6. Remove the four socket head capscrews (157) and lockwashers (156). Install two of the screws in the threaded holes in the rotor (55b). Alternately tighten the screws until the rotor comes off. See Fig. 40.
7. Skip ahead to **Reassembly**, page 40, Step 6, or continue on the next page.

-  Torque to 7 ft-lb (9.5 N.m)
-  Pinion shaft
-  Threaded holes

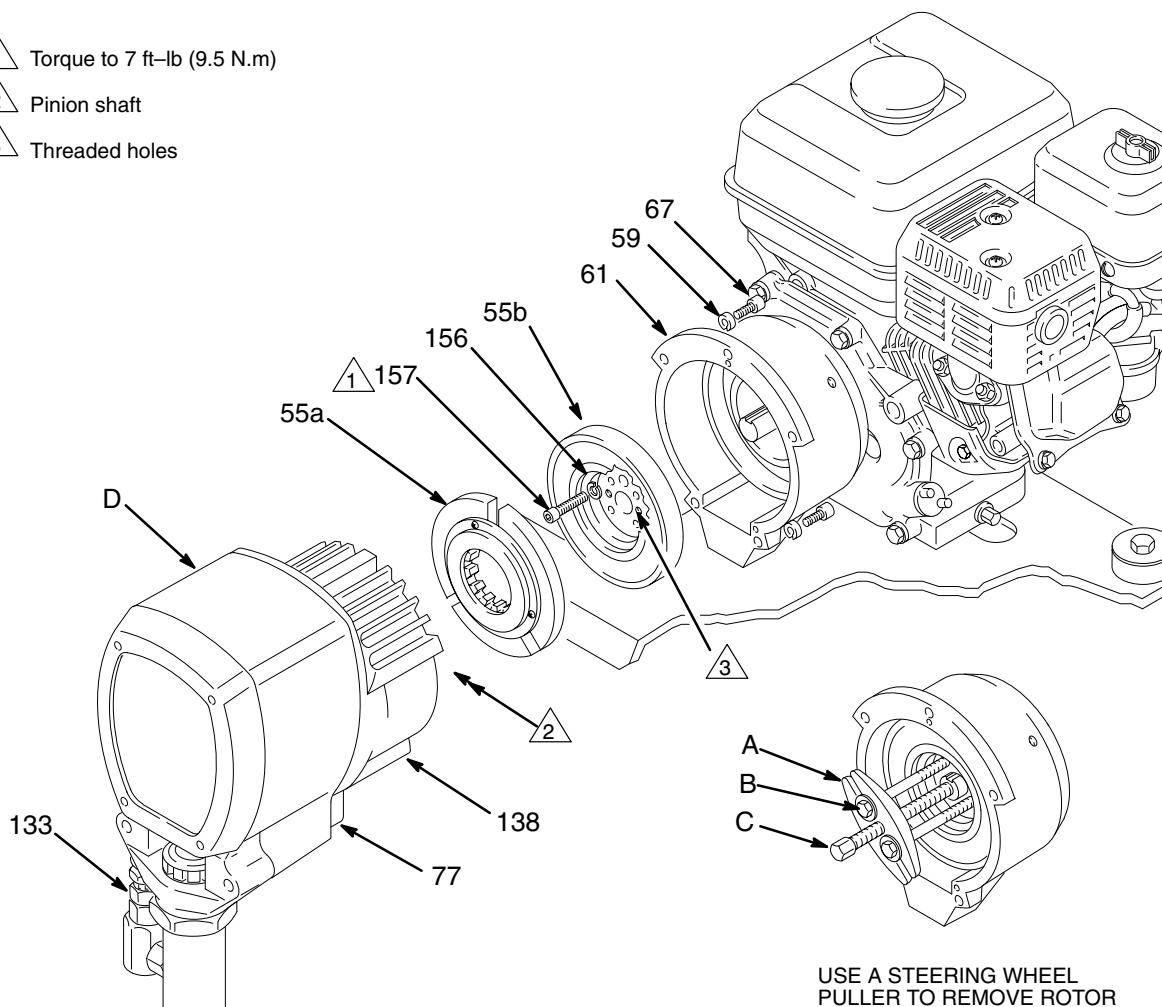

USE A STEERING WHEEL
PULLER TO REMOVE ROTOR

0044A

Fig. 40

Clutch Rotor/Field Adjustment

WARNING

To reduce the risk of serious injury whenever you are instructed to relieve pressure, always follow the **Pressure Relief Procedure** on page 7.

Tool List

- 3/8 in. hex key wrench
- 1/4 in. hex key wrench
- Cleaning solvent

Adjustment See Fig. 41.

1. Remove any residue from the clutch housing (61).
2. Seat the field (70) squarely in the clutch housing. Do not tighten the four field set screws (62).
3. Install the rotor (4b). Set the clearance between the outside diameter of the rotor and the inside diameter of the field with the four 0.010 in. (0.25 mm) gages (A), supplied. Place the gauges 90° apart.
4. Adjust the position of the field with the four field set screws to maintain 0.010 in. (0.25 mm) minimum clearance all the way around the rotor.
5. Tighten the four field set screws, evenly, to 27 in-lb (3.1 N.m). Remove the four gauges.

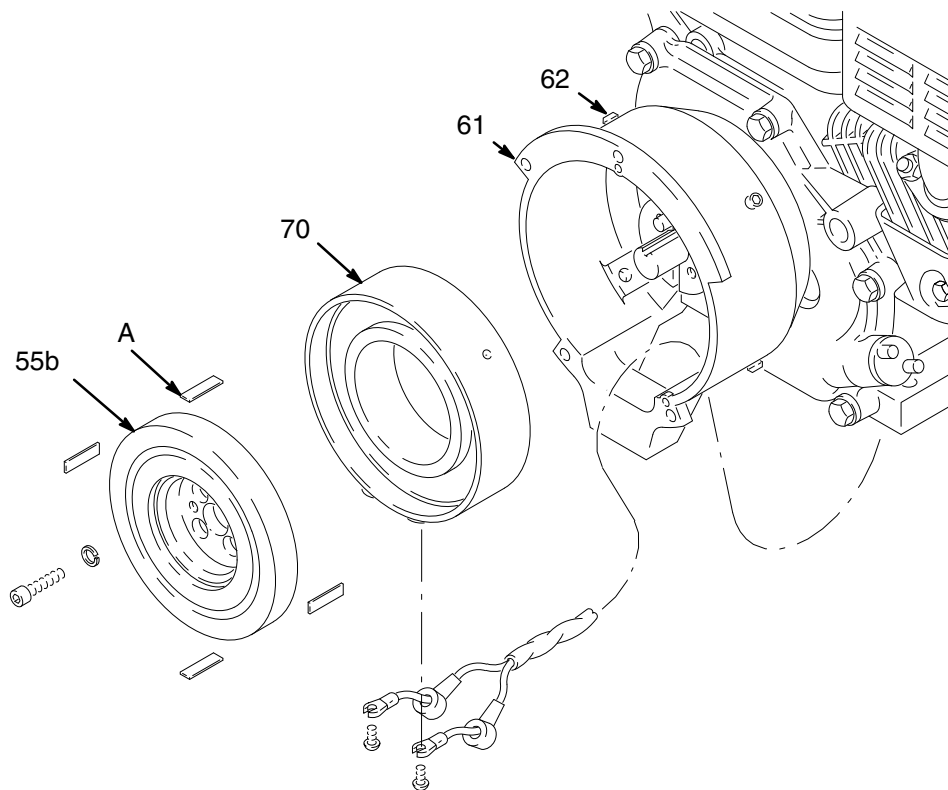

Fig. 41

05701

Engine

1. Working under the mounting plate (25) of the cart, remove the screw (51), lockwasher (132) and washer (50) which hold the clutch housing (61) to the cart. See Fig. 42.
2. Still working under the mounting plate, remove the two locknuts (40), and then pull the screws (63) out of the base of the engine. Disconnect the red wire from the engine lead. Disconnect the black and white wires (58) from the field. Pull the wires carefully through the grommets before removing the engine. See Fig. 42 and 43.

3. Lift the engine carefully and place it on a work bench.
4. Remove the **Field and Wiring Harness, Clamp** and **Clutch Housing**, as instructed on pages 37 and 38.
5. Skip ahead to **Reassembly**, page 39, Step 1.

NOTE: All service to the engine must be performed by an authorized HONDA dealer.

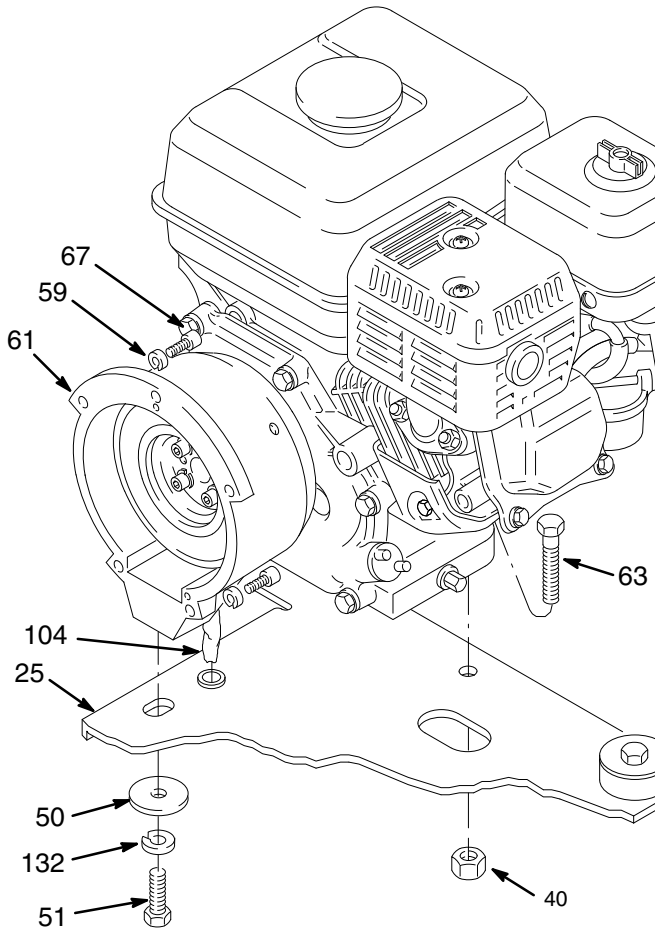

Fig. 42 0045

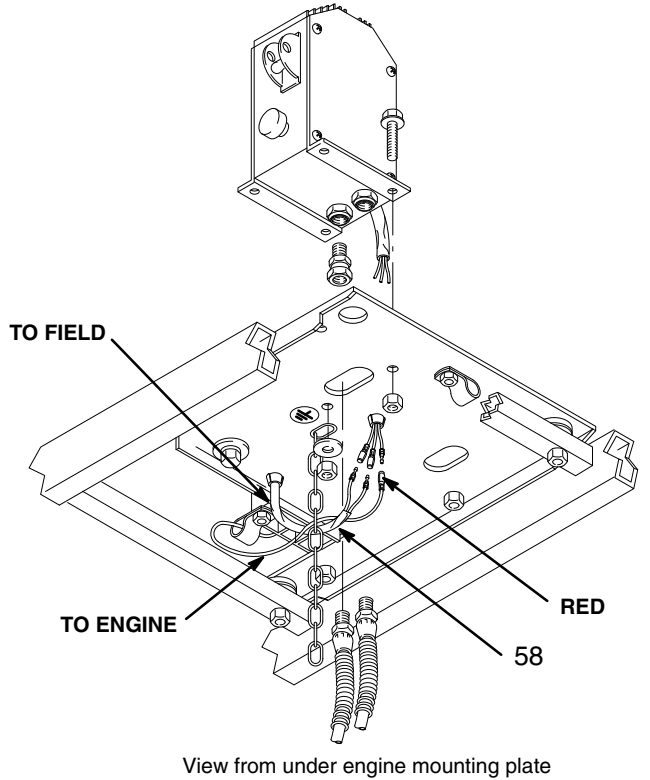

Fig. 43 0032

Field & Wiring Harness

NOTE: Refer to Fig. 44.

1. Loosen the four setscrews (62) holding the field (70) to the clutch housing (61). Unplug the wiring harness (58) from under the engine mounting plate. Pull the field out to expose the black and white wires (58).
2. Pull the caps (A) of the wire screws (57) in both places on the field. Loosen the screws and release the wires (58).
3. Skip ahead to **Reassembly**, page 39, Step 4.

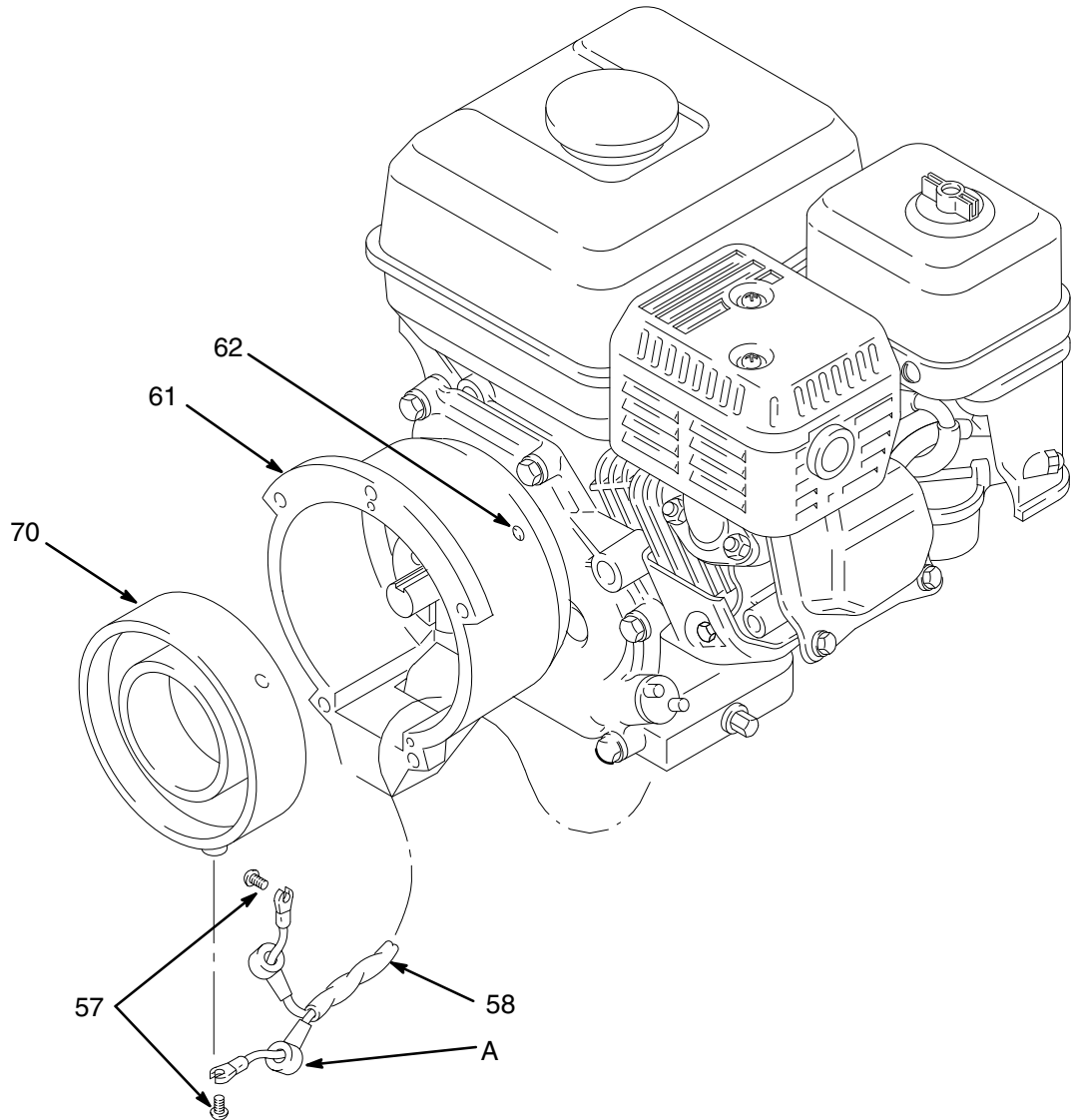

Fig. 44

0046

Clamp

NOTE: A standard steering wheel puller is required to remove the clamp. Two 1/4–28 x 3 or 4 in. long screws are also needed.

NOTE: Refer to Fig. 45.

1. Loosen the two screws (60) on the clamp (68), working through the slot at the bottom of the clutch housing (61).
2. Install two screws (B) of the tool (A) in two of the threaded holes in the clamp. Tighten the screws (C) until the clamp comes off.
3. Skip ahead to **Reassembly**, page 39, Step 3, or continue below.

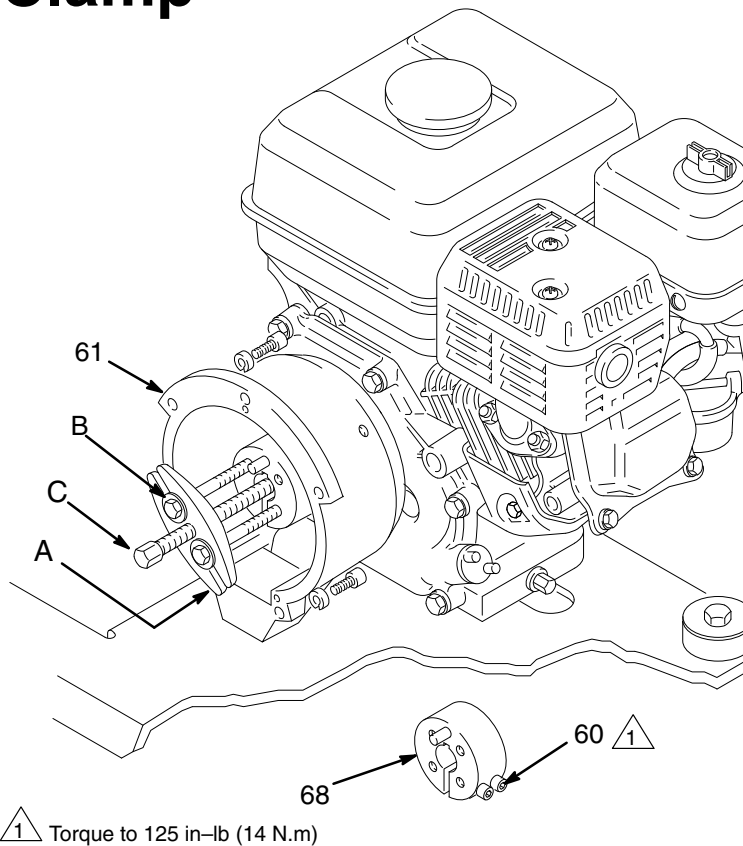

 Torque to 125 in-lb (14 N.m)

Fig. 45

0047

Clutch Housing

NOTE: Refer to Fig. 46.

1. Remove the four capscrews (156) and lock-washers (157) which hold the clutch housing (61) to the engine (64).
2. Remove the engine key (66).
3. Pull off the clutch housing (61).
4. Skip ahead to **Reassembly**, page 39, Step 1.

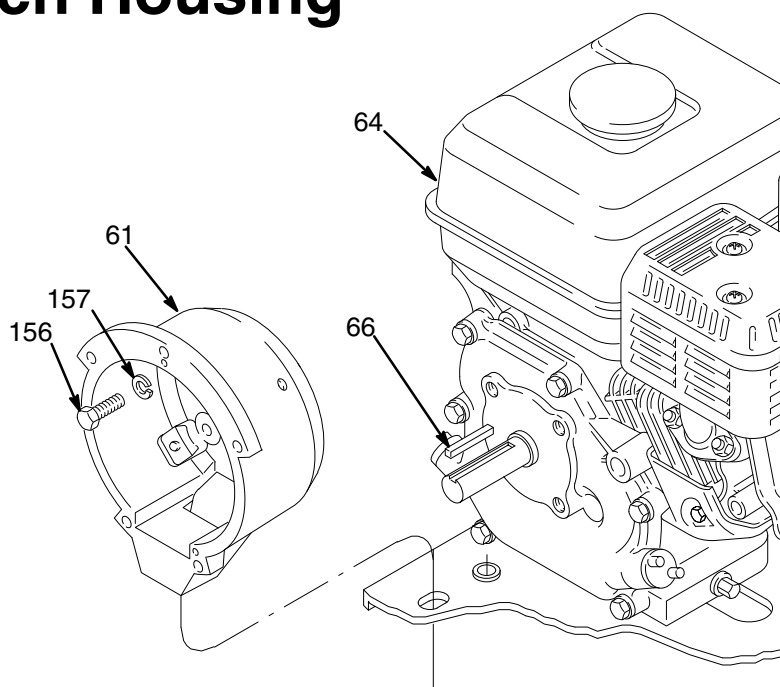

Fig. 46

0048

Reassembly

1. Install the **clutch housing (61)**, capscrews (156) and lockwashers (157) on the engine. See Fig. 47.
2. Install the engine shaft **key (66)**. See Fig. 47.
3. Install the **clamp (68)** onto the engine shaft (A). Maintain the 1.99 in. \pm 0.01 (50.55 mm) dimension shown in Fig. 48.

To check the dimension, place a rigid, straight steel bar (B) across the face of the clutch housing (61). Use an accurate measuring device to measure the distance between the inside of the bar and the face of the clamp. Adjust the clamp as necessary. Torque the two screws (60) to 125 in-lb (14 N.m).

4. Connect the wires of the harness (58) to the screws (57) in both places on the field. Pull the plastic caps (C) up and snap them over the screws. Guide the wires of the harness (58) through the slot in the clutch housing. Slide the **field (70)** into the clutch. Align the setscrew chamfers in the field and the clutch housing (61). Tighten the setscrews (62) oppositely and evenly, to 25 in-lb (2.8 N.m). See Fig. 47.

1 Torque oppositely and evenly to 25 in-lb (2.8 N.m)

2 Connect wiring harness (58) here before sliding field (70) into housing (61)

3 Torque to 125 in-lb (14 N.m)

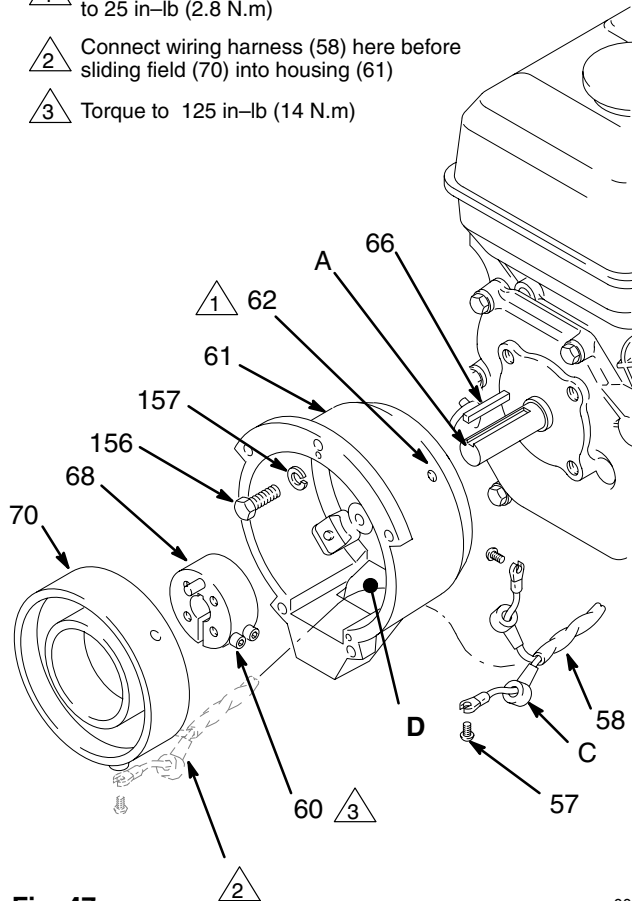
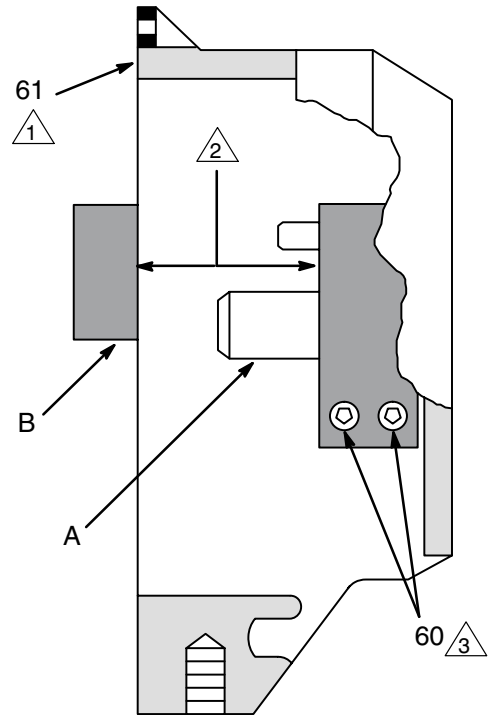

Fig. 47

0049

- 1 Face of housing
- 2 1.99" (50.55 mm)
- 3 Torque to 125 in-lb (14 N.m)



SIDE CUTAWAY VIEW OF CLUTCH HOUSING

Fig. 48

0050

Reassembly

- Place the **engine (64)** assembly on the cart. Align the mounting holes. Guide the engine wire (A) through the clamp at the rear of the mounting plate (25). See Detail A. Guide the wiring harness (58) from the field, through the grommet (24) in the mounting plate (25). Install the serrated flange screws (63) and nuts (40) and torque to 15 ft-lb (20.4 N.m). Install the capscrews (51), lockwashers (132) and washer (50) from under the engine mounting plate to secure the clutch housing (61). Connect the engine wire (A) to the red wire, and connect the black and white wires of the pressure control at **B** as shown in the Detail A, Fig. 49.
- Be sure the face of the **rotor (55b)** and the field (61) is free of all oil and contaminants. Install the rotor, lockwashers (59) and capscrews (60). Torque the capscrews to 7 ft-lb (9.5 N.m). See Fig. 49.

After installing the rotor (55b), pull the engine recoil rope to assure that the engine turns freely, and there is no friction between the between the rotor (55b) and the field (70). If there is friction, loosen the setscrews (62) and reposition the field (70) as necessary. Tighten the setscrews oppositely and evenly to 25 in-lb (2.8 N.m) Also make sure there are no burrs on the outside edge of the rotor.

- Be sure the face of the **armature (55a)** is clean. Assemble the armature to the shaft in the pinion housing (C). A retaining ring located within the armature makes it difficult to assemble these parts. For the best results, first engage a few splines of both parts, then use a screwdriver to gently push the retaining ring into the armature, and then engage the remaining splines. Push the armature onto the shaft until it contacts the ring.
- Assemble the **drive/pinion housing (C)** to the clutch housing, using the capscrews (67) and lockwashers (59). See Fig. 49.

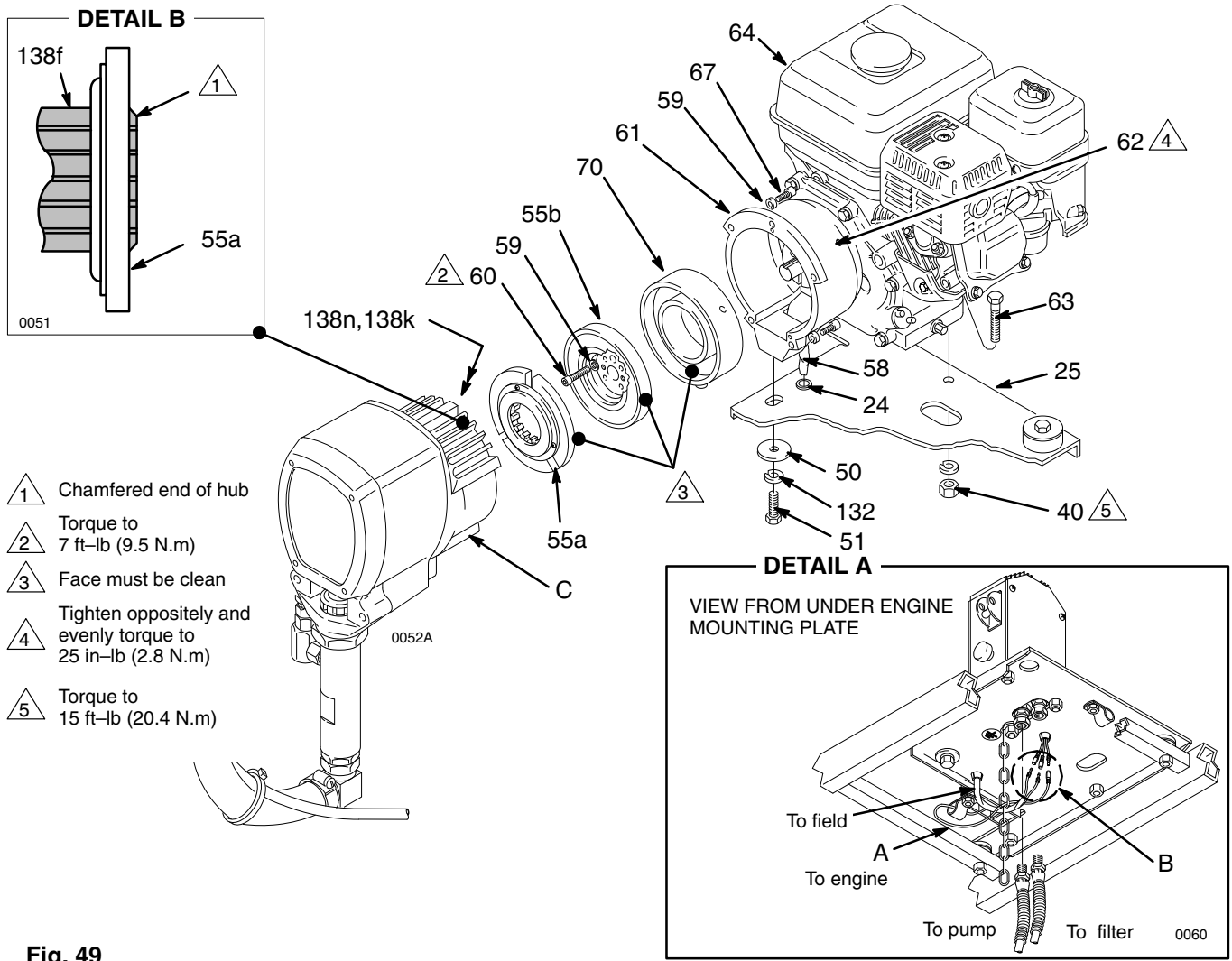

Fig. 49

Parts – Displacement Pump

Model 220–872, Series A

Sleeved Displacement Pump

Includes items 202 to 225

Ref.

No.	Part No.	Description	Qty.
202*	107–098	PACKING, o-ring, PTFE®	1
203*	108–690	SEAL, u-cup, polyurethane	1
204*	108–775	BALL	1
205	183–171	PLUG 1	1
206*	183–174	V-PACKING, leather	2
207*	183–175	V-PACKING, leather	2
208*	183–176	GLAND, male	1
209*	183–177	GLAND, female	1
210*	183–178	GLAND, male	1
211	183–179	NUT, hex, retaining	1
212*	183–182	V-PACKING, polyethylene	3
213*	183–183	V-PACKING, polyethylene	3
214*	186–653	WASHER, backup	1
215*	183–185	GLAND, female	1
216	183–186	NUT, packing	1
217*	183–172	GASKET	1
218	188–148	SLEEVE, cylinder	1
219	183–181	CYLINDER	1
220	183–180	GUIDE, ball	1
221*	183–173	PIN, ball stop	1
222	235–499	VALVE, piston	1
223	220–629	VALVE, intake	1
224	235–498	ROD, piston	1
225*	101–947	BALL	1

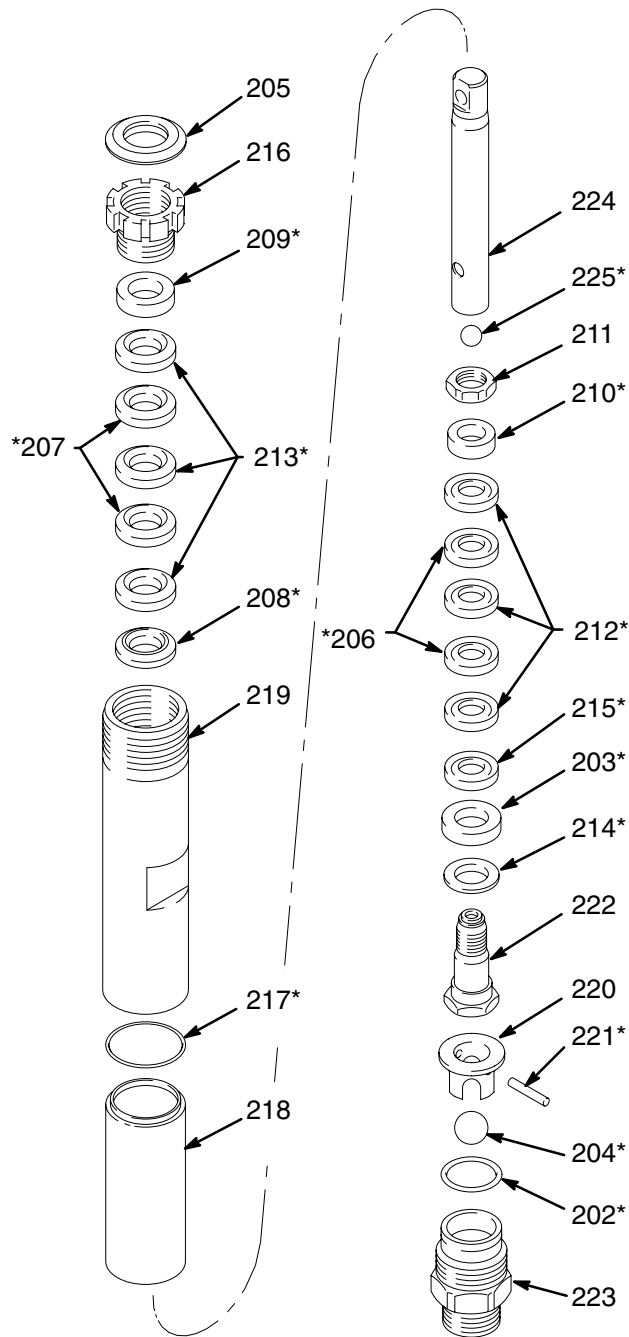

* These parts are also included in Repair Kit 220–877, which may be purchased separately.

Parts –Pressure Control

Part No. 222-369 – Replacement Pressure Control for All GM 5000 Sprayers

Part No. 222-369 includes all items marked with a †. It does not include unmarked items. Order the Basic Control, 222-369, and/or items 309 or 313 as needed.

Ref. No.	Part No.	Description	Qty.	Ref. No.	Part No.	Description	Qty.
300†	222-380	PRESSURE CONTROL <i>Includes items 302 to 304</i>	1	310†	100-035	SCREW, mach, slotted pan hd, 8-32 x .312"	1
301†	183-466	LABEL, caution	1	311†	108-783	SCREW, mach, flat hd; 8-32 x .812"	1
302†	111-930	ON/OFF SWITCH	1	313	108-852	CONNECTOR, 45°	1
303†	105-659	BOOT, switch	1	316†	222-352	TRIAC	1
304†	107-255	GUARD, locking	1	317†	107-070	SCREW, flat head, 6-32 x .625	2
305†	157-021	LOCKWASHER, No. 8, internal	2	318†	100-072	NUT, hex, 6-32	2
306†	100-284	NUT, hex, 8-32	1	319†	103-181	LOCKWASHER, No. 6, external	2
308†	220-979	CONDUCTOR, red	2	320†	101-754	PLUG, pipe, 3/8 npt	1
309	220-978	CONDUCTOR, red, white, black	1				

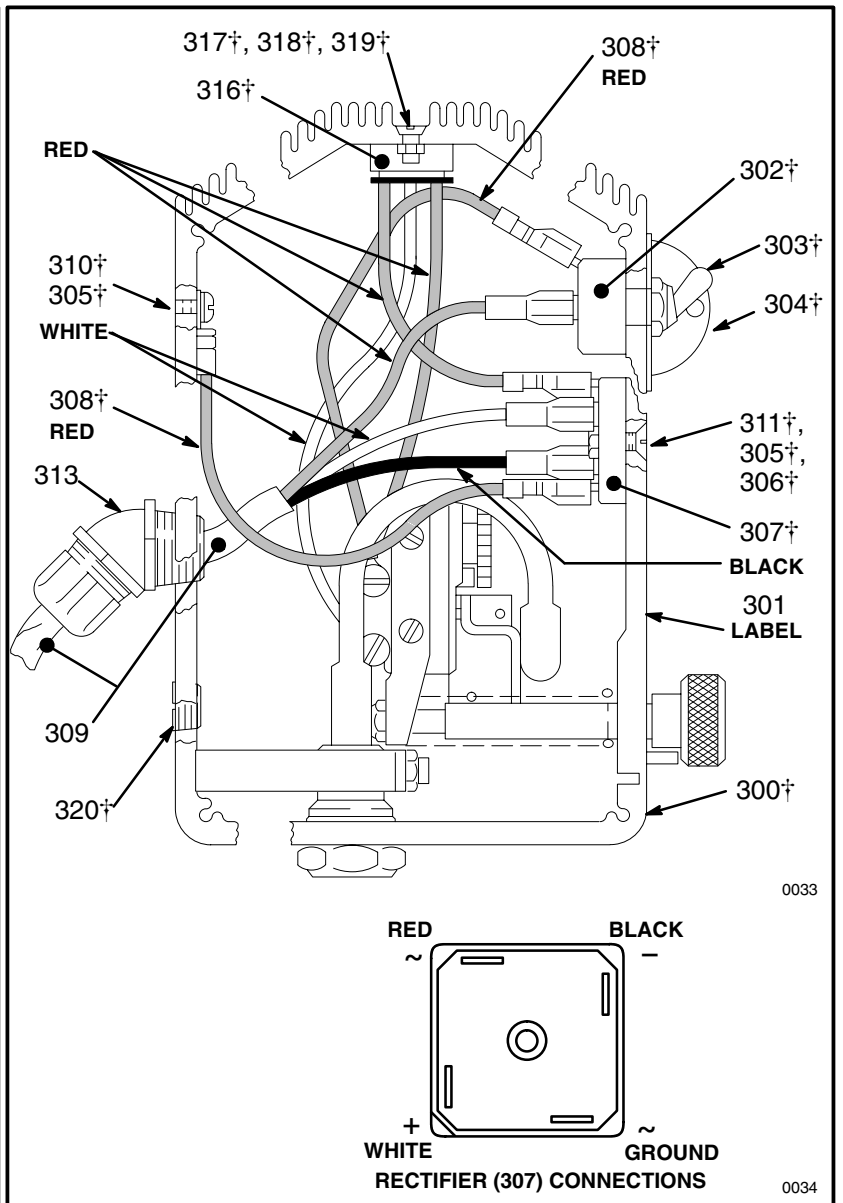
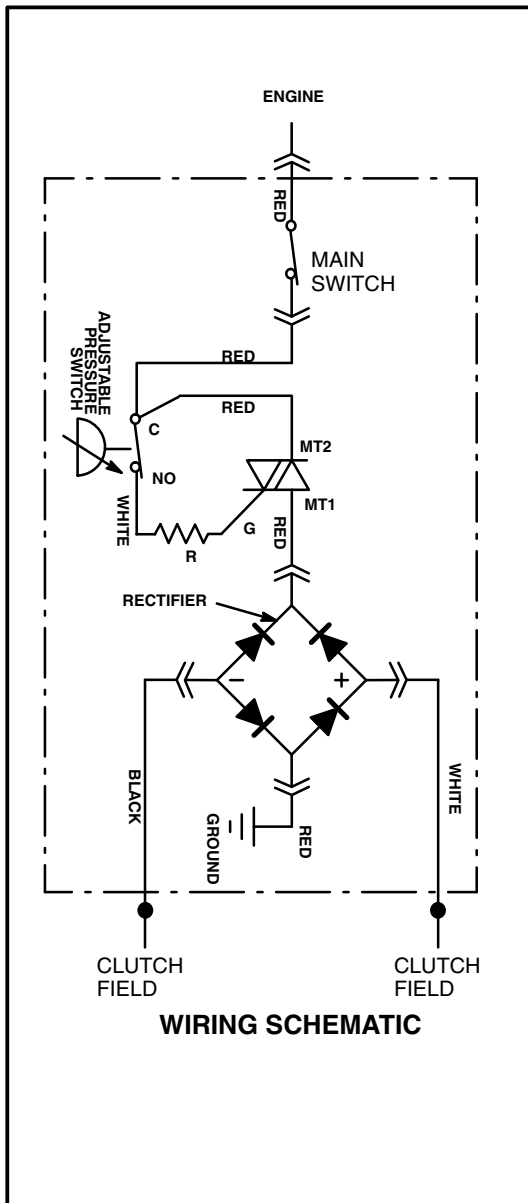

Parts – Cart

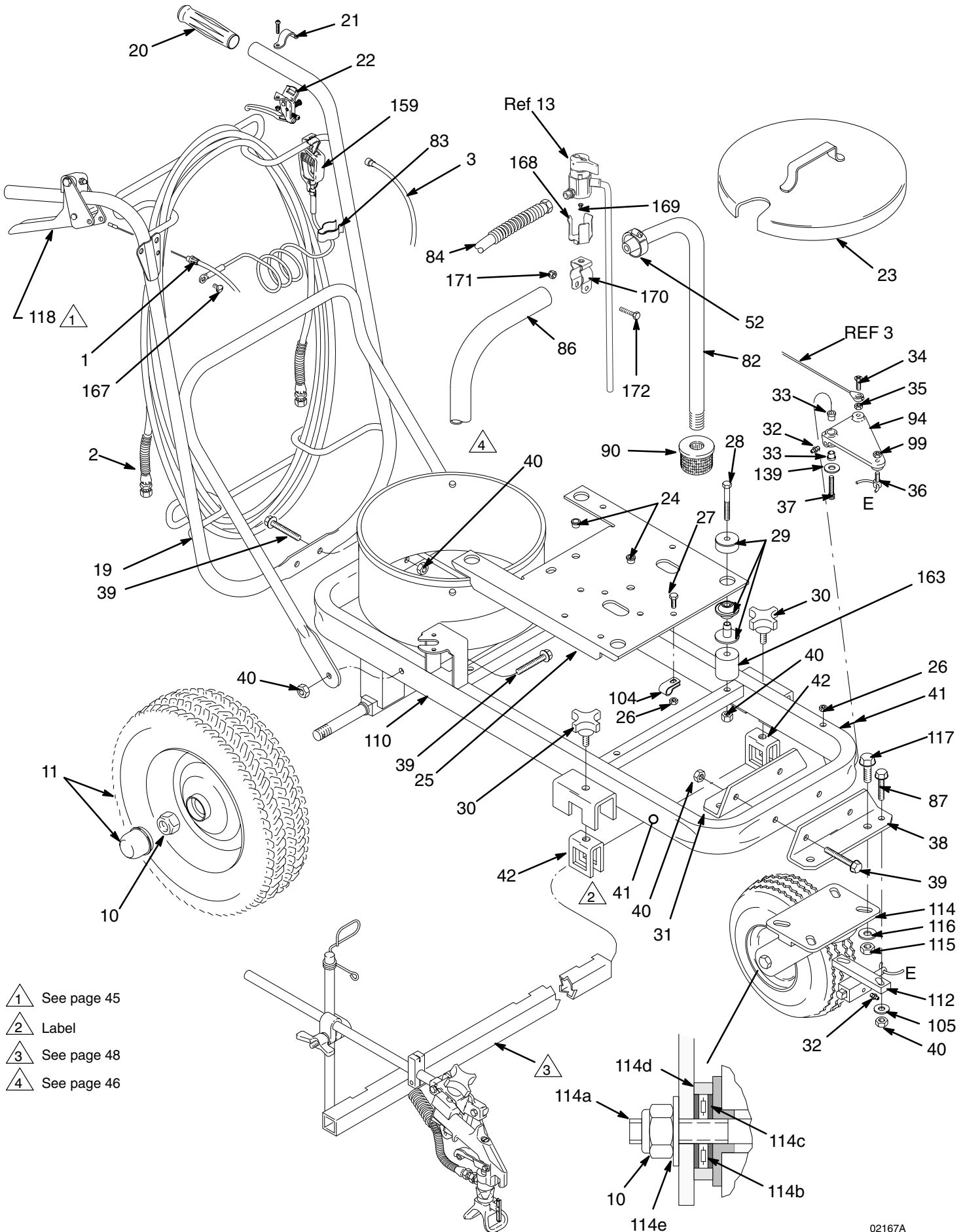

- 1 See page 45
- 2 Label
- 3 See page 48
- 4 See page 46

Parts – Cart

Model 231–133, Series A With one gun
Includes items 1–172

Ref. No.	Part No.	Description	Qty.
1	111–154	CABLE, dual gun selector, 9.6 ft (2.9 m)	1
2	238–361	HOSE, nylon, 1/4" x 50 ft (15 m) ID, cpld 1/4 npsm, grounded, spring guards both ends	1
3	111–153	CABLE, 4.3 ft (1.3 m)	1
10	112–405	NUT	3
11	111–020	WHEEL, pneumatic, 16" dia.	2
19	224–021	HANDLE	1
20	108–063	GRIP, handle	2
21	186–787	BRACKET, release lever	1
22	111–197	LEVER, release	1
23	235–697	COVER, pail	1
24	109–099	BUSHING, snap	2
25	186–672	PLATE, mounting	1
26	111–040	LOCKNUT, 5/16–18 w/nylon insert	1
27	110–963	SCREW, serrated flange, hex hd, 5/16–18 x 3/4"	1
28	111–236	CAPSCREW, hex hd, 3/8–16 x 4–1/2"	4
29	104–766	MOUNT, motor	4
30	108–471	KNOB	2
31	186–668	BRACKET, rear caster	1
32	100–846	FITTING, lubrication	1
33	111–016	BEARING, flanged	2
34	111–230	SCREW, mach, flhd, 1/4–20 x 1"	1
35	100–015	NUT, hex, 1/4–20	1
36	186–814	PIN, pivot	1
37	103–262	CAPSCREW, sch, 5/16–18 x 3–1/2"	1
38	186–731	BRACKET, front caster	1
39	111–194	CAPSCREW, serrated flange hd, 3/8–16 x 2"	6
40	101–566	LOCKNUT, 3/8–16 w/nylon insert	12
41▲	186–821	LABEL, Warning (trigger cable)	2
42	224–136	CLAMP, extension	2
52	101–818	CLAMP, hose, 1–3/4"	1
82	170–957	TUBE, suction, 5 gal, 1" pipe	1
83	178–342	CLIP, spring	3
84	238–959	HOSE, cpld 3/16" x 60"	1
85	103–473	WIRE TIE STRAP	2
86	185–381	HOSE, suction, 1" ID x 41"(1041 mm)	1
87	111–193	CAPSCREW, serrated flange, hex hd, 3/8–16 x 7/8"	3
90	187–072	STRAINER, 16 mesh	1
94	186–747	LEVER, actuator	1
99	101–345	NUT, hex, jam, 1/4–20	1
104	108–868	CLAMP, wire	2

Model 231–141 With two guns
Includes items 1–172, and 401–405 (see page 48)

Ref. No.	Part No.	Description	Qty.
105	100–731	WASHER, 3/8"	2
107	186–620	LABEL, grounding, <i>not shown</i>	1
110	224–019	CART	1
112	224–066	CASTER LATCH ASSY <i>Includes 1 of item 32</i>	1
114	237–832	SWIVEL CASTER <i>Includes items 114a–114c</i>	1
114a	112–820	SCREW, cap, hex hd	1
114b	112–822	BEARING, needle	1
114c	112–823	RACE, needle	1
114d	112–824	SEAL	1
114e	112–825	SPRING, Belleville	1
115	801–020	NUT, 1/2–13 w/nylon insert	4
116	101–044	WASHER, flat, 1/2"	4
117	111–195	CAPSCREW, serrated flange, hex hd, 1/2–13 x 1–1/4"	4
118	224–144	REMOTE TRIGGER KIT <i>Includes items 118a to 118e</i>	1
118a	111–018	.SPRING, compression	1
118b	111–206	.BEARING, ball, 3/32"	1
118c	186–746	.TRIGGER	1
118d	186–694	.SPOOL, cable selector	1
118e	186–832	.KNOB	1
119	186–695	BLOCK, mounting	1
120	190–098	PIN, trigger pivot	1
121	111–017	BEARING, flanged	2
122	186–696	PLATE, lever	2
127	107–110	LOCKNUT, with nylon insert, 10–32 unf-2b	1
139	107–194	WASHER, flat 3/8"	1
147	206–994	THROAT SEAL LIQUID, 8 oz (0.27 l)	1
159	237–686	GROUNDING CLAMP ASSY	1
163	186–715	SPACER	4
164	111–235	SCREW, mach, pnh, 10–24 x 1.25"	1
165	235–456	BRAKE KIT <i>See manual 308–227 for instructions</i>	1
166	100–718	WASHER	1
167	112–798	SCREW, hex, hd, thd forming	1
168	191–874	BRACKET, pressure relief	1
169	113–789	SCREW, mach, truss hd 8–32 x 0.5"	1
170	113–791	CLAMP, pressure relief	1
171	102–040	NUT, lock	1
172	100–014	SCREW, cap hex hd	1

▲ Replacement Danger and Warning labels, tags and cards are available at no cost.

REMOTE TRIGGER DETAIL,
Ref No. 118, Includes 118a–118e

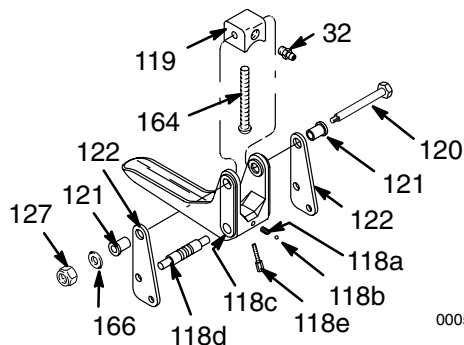

0005

BRAKE KIT, Ref No. 165
Includes solid colored parts

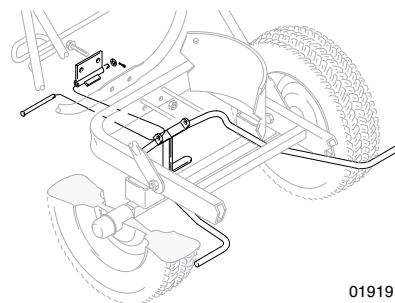

01919

Parts – Mechanical

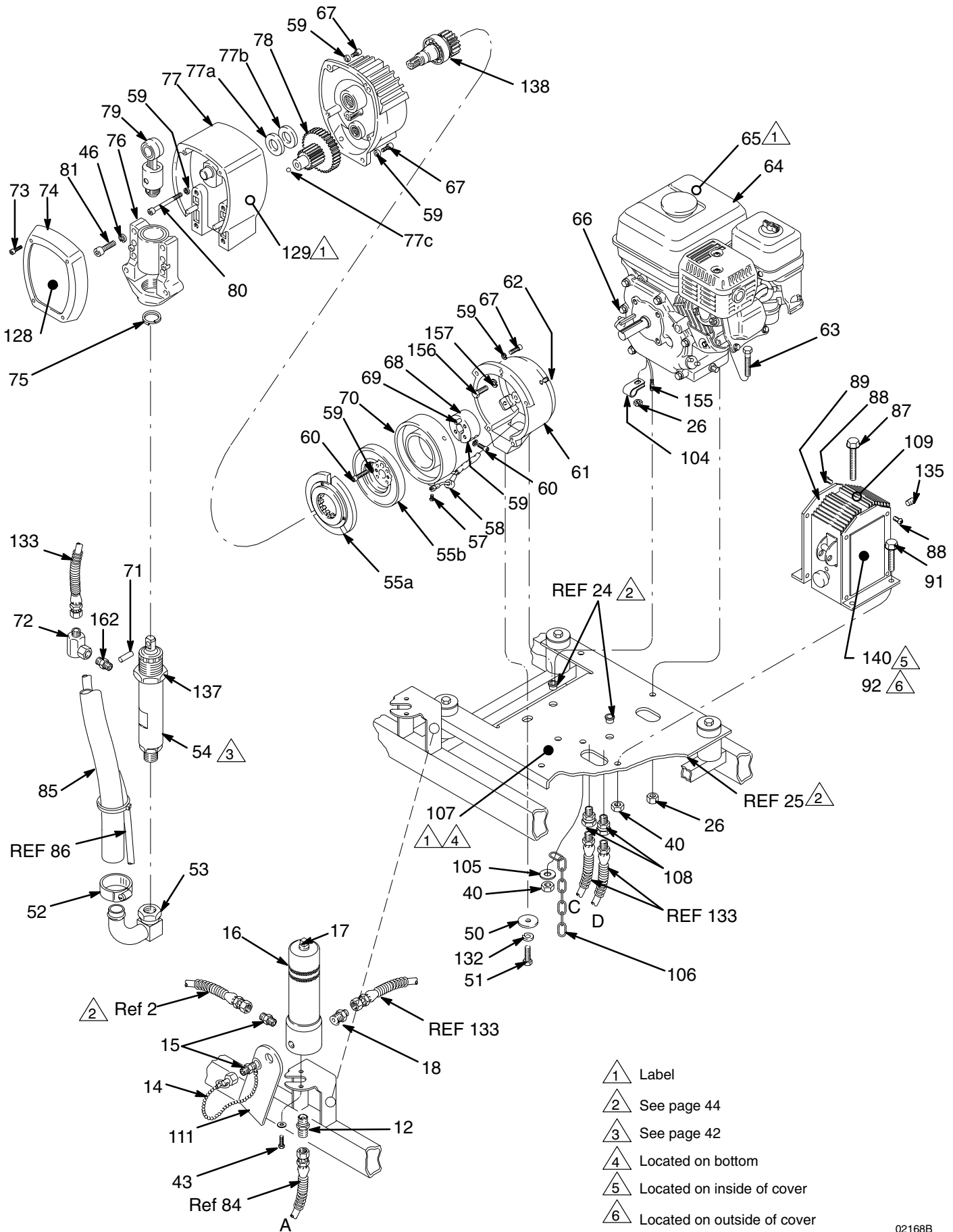

Parts – Mechanical

Ref. No.	Part No.	Description	Qty.	Ref. No.	Part No.	Description	Qty.
12	162-453	NIPPLE, hex 1/4 npt x 1/4 npsm 1-3/16" long	1	75	183-169	SPRING, retaining	1
13	238-960	VALVE, pressure relief	1	76	220-639	BEARING HOUSING KIT	1
14	220-285	CAP, secondary fluid outlet	1	77	220-638	DRIVE HOUSING	
15	162-453	NIPPLE, hex, 1/4 npt x 1/4 npsm 1-3/16" long	2			<i>Includes items 77a to 77c</i>	1
16	218-029	FLUID FILTER, <i>see 307-273 for parts</i>	1	77a	106-227	. WASHER, bronze	1
17	100-040	PLUG, 3/8 npt	1	77b	183-209	. WASHER, silver	1
18	162-485	ADAPTER, 3/8 npsm x 3/8 npt	1	77c	100-069	. BALL	1
26	111-040	LOCKNUT, 5/16-18 w/nylon insert	3	78	220-919	GEAR REDUCER KIT	1
40	101-566	LOCKNUT, 3/8-16 w/nylon insert	4	79	220-640	CONNECTING ROD	1
43	110-997	SCREW, serrated flange, hex hd, 1/4-20 x 5/8"	2	80	108-849	CAPSCREW, hex sch; 1/4-20 x 3"	2
46	106-115	LOCKWASHER, 3/8", high collar	4	81	110-141	CAPSCREW, sch; 3/8-16 x 1-1/2" (special)	4
50	108-851	WASHER, plain, 3/8"	1	85	103-473	WIRE TIE STRAP	1
51	100-469	CAPSCREW, hex hd; 3/8-16 x 3/4"	1	87	111-193	CAPSCREW, serrated flange hex hd, 3/8-16 x 1-1/4"	1
52	101-818	CLAMP, hose, 1-3/4"	1	88	110-885	SCREW, pnh, thread forming, 10-24 x 3/8"	8
53	110-194	UNION, 180°, 1" ID hose x 3/4 npsm swivel	1	89	186-663	BRACKET, pressure control	2
54	220-872	DISPLACEMENT PUMP KIT <i>see page 42 for parts</i>	1	91	111-192	CAPSCREW, serrated flange hex hd, 3/8-16 x 7/8"	3
55	236-568	CLUTCH ASSEMBLY <i>Includes items 55a and 55b</i>	1	92	186-856	LABEL	1
55a		ARMATURE	1	105	100-731	WASHER, 3/8"	1
55b		ROTOR, clutch	1	106	186-811	GROUND CHAIN, heavy, 17-5/8" long	1
57	108-860	SCREW, mach, slotted, bdgh 8-32 x 1/4"	2	107	186-620	LABEL, grounding	1
58	220-980	CONDUCTOR, electrical	1	108	157-705	UNION, straight, 1/4 npt(m) x 3/8 npt(f) swivel	2
59	105-510	LOCKWASHER, 1/4"	17	109	222-369	PRESSURE CONTROL KIT	1
60	108-803	CAPSCREW, hex sch; 1/4-28 x 1"	6	111▲	178-034	TAG, WARNING <i>at filter</i>	1
61	183-397	CLUTCH HOUSING KIT	1	128	186-758	LABEL, identification, drive cover	1
62	108-801	SETSCREW, 1/4-20 x 5/16"	4	129▲	185-953	LABEL, DANGER <i>on drive housing</i>	1
63	110-837	SCREW, serrated flange, hex hd, 5/16-18 x 1-1/2"	3	132	100-133	LOCKWASHER, 3/8"	1
64	108-802	ENGINE, gasoline, 5 HP	1	133	222-516	HOSE, 3/8" ID x 29", cpld 3/8 npt(m) x 3/8 npsm(f), spring guard both ends	2
65▲	181-867	LABEL, WARNING <i>on engine</i>	1	135	101-754	PLUG, pipe, 3/8 npt	1
66	183-401	KEY, shaft	1	137	189-969	NUT, hex (special)	1
67	100-644	CAPSCREW, hex sch; 1/4-20 x 3/4"	9	138	220-920	PINION HOUSING	
68	183-517	CLAMP, mounting, rotor	1			<i>See parts on page 49</i>	1
69	108-800	PIN, dowel; 5/16 x 1"	1	140▲	177-762	LABEL, WARNING <i>inside pressure control cover</i>	1
70	183-400	FIELD KIT	1	155	224-128	WIRING HARNESS	1
71	183-210	PIN, 3/8 x 1-1/8" (special)	1	156	108-842	CAPSCREW, sch, 5/16-24 x 3/4"	4
72	155-494	UNION, 90°, 3/8 npt x 3/8 npsm swivel	1	157	100-214	LOCKWASHER, 5/16"	4
73	108-850	SCREW, mach, filh; 8-32 x 1-1/4"	4	162	183-461	ADAPTER, 1/4 npt(m) x 3/8 npsm (m)	1
74	183-168	DRIVE HOUSING COVER KIT	1				

▲ Replacement Danger and Warning labels, tags and cards are available at no cost.

Parts – Gun Mounting

Ref. No.	Part No.	Description	Qty.
4	224-052	BRACKET, gun support	1
6	111-817	CLAMP, arm support	1
7	188-135	GUIDE, cable	1
32	100-846	FITTING, lubrication	1
33	111-016	BEARING, flanged	2
34	111-230	SCREW, mach, flhd, 1/4-20 x 1"	1
35	100-015	NUT, hex, 1/4-20	1
44	100-016	LOCKWASHER, 1/4"	2
45	181-734	ARM, support	1
47	100-101	CAPSCREW, hex hd, 3/8-16 x 1"	1 or 2
48	186-699	BLOCK, mounting cable	1
49	100-021	CAPSCREW, hex hd, 1/4-20 x 1"	2
93	181-818	KNOB	1
94	186-747	LEVER, actuator	1
95	188-452	HOLDER, gun	1
96	108-483	SCREW, shoulder, sch, 1/4 x 3/8"	1
97	181-795	JAW, clamp	1
98	235-459	FLEX GUN <i>See manual 308-235 for parts</i>	1
99	101-345	NUT, hex, jam, 1/4-20	2
100	108-535	BEARING, sleeve	1
101	107-445	CAPSCREW, sch, 1/4-20 x 1-1/2"	1
103	111-045	SCREW, shoulder, sch, 5/16 x 1"	1
113	LLT-319	Line Lazer Tip, Sz 319	1
123	110-755	WASHER	1
132	100-133	LOCKWASHER, 3/8"	1
136	237-859	RAC IV DripLess TIP GUARD	1
158	221-517	SwitchTip, Size 517	1

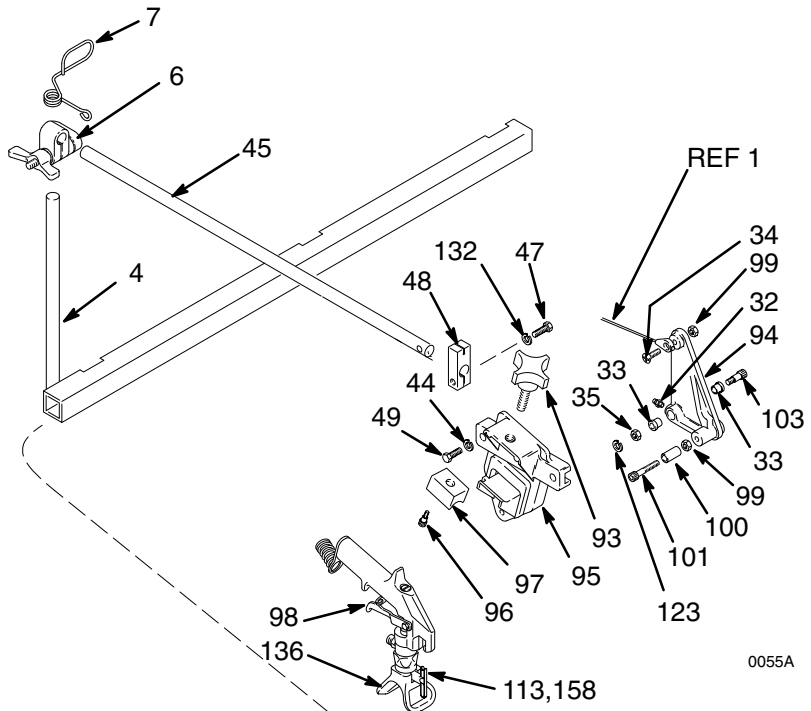

0055A

OPTIONAL SECOND GUN AND HOSE KIT Model 224-097

Included with Sprayer Model 231-141 only

This kit includes the parts shown in the box to the right, which includes items 401-405 and the items listed above except 4.

Ref. No.	Part No.	Description	Qty.
401	178-342	CLIP, spring	1
402	111-155	CABLE, remote trigger	1
403	224-068	HOSE, 1/4" ID, cpld 1/4-18 npsm(f) 6.5 ft (1.2 m) grounded, spring guards	1
404	224-096	BRACKET, support, extension	1
405	224-071	CLAMP, extension	2

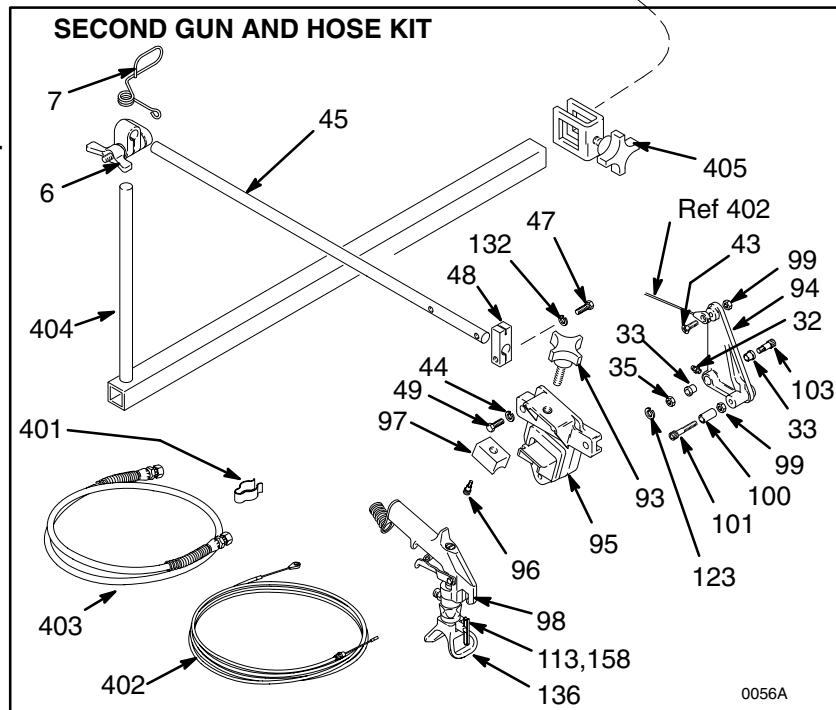

0056A

Parts – Pinion Assembly

Ref No. 138 Pinion Housing

Includes items 138a to 138f

Ref. No.	Part No.	Description
138a	221-032	PINION SHAFT ASSEMBLY Includes items 138b to 138f
138b	183-395	.SHAFT, pinion
138c	108-797	.BEARING, needle
138d	108-798	.BEARING, ball
138e	108-796	.RING, retaining, external
138f	183-396	.HUB, armature

Ref. No.	Part No.	Description	Qty.
----------	----------	-------------	------

NOTE: Items 138h to 138p are not included in a kit. Order them separately as needed.

Ref. No.	Part No.	Description	Qty.
138h	108-692	BEARING, ball, roller	1
138j	107-088	BEARING, ball, needle	1
138k	100-069	BALL, sst	1
138m	108-799	RING, retaining, internal	1
138n	105-489	PIN, dowel	2
138p	183-394	HOUSING, pinion	1

1 Lubricate exterior

2 Lubricate inner and outer diameters

3 Lubricate teeth

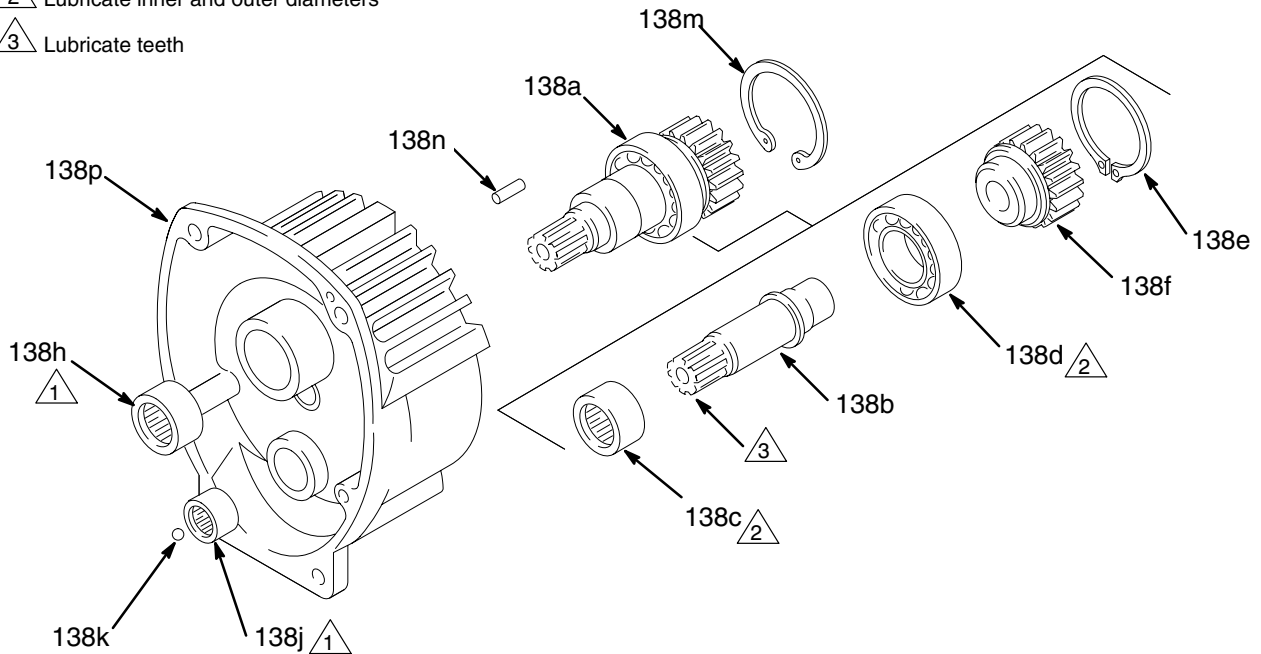

0042

Technical Data

Engine	5.5 Horsepower, Honda
Maximum Working Pressure	3000 psi (207 bar, 20.7 MPa)
Noise Level	
Sound Power	105 dbA
Sound Pressure	97 dbA @ 1 meter under maximum operating conditions per ISO-3744
Cycles/Gallon (liter)	200 (53)
Maximum Delivery	1.25 gpm (4.7 liter/min)
Fuel Tank Capacity	0.95 gallons (3.6 liter)
Maximum Tip Size	1 gun with 0.035 tip; 2 guns with 0.025 tip 3 guns with 0.019 tip
Inlet Paint Strainer	16 mesh (1190 micron) Stainless Steel screen, reusable
Outlet Paint Filter	60 mesh (250 micron) Stainless Steel screen, reusable
Pump Inlet Size	3/4 npt (m)
Fluid Outlet Size	1/4 npsm from fluid filter
Wetted parts	
Displacement Pump	Zinc-Plated Carbon Steel, Stainless Steel, Chrome-Plated Stainless Steel, Polyethylene, Tungsten Carbide, Leather, Polyurethane
Filter	Zinc-Plated Carbon Steel, Stainless Steel
Weight (dry, without packaging)	237 lb (107 kg)
Height	40 in. (1016 mm)
Length	56 in. (1422 mm)
Width	37 in. (940 mm)

Accessories

USE ONLY GENUINE GRACO PARTS AND ACCESSORIES

DANGER LABELS

The English language DANGER label shown on page 1 is also on your sprayer. If you have painters who do not read English, order one of the following labels to apply to your sprayer. The drawing below shows the best placement of these labels for good visibility. Order the labels directly from Graco, free of charge.

Toll Free: 1-800-328-0211

Apply other language here

French	185-956
Spanish	185-961
German	186-041
Greek	186-045
Korean	186-049
English	185-953

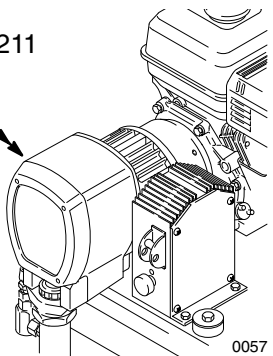

FLEX GUN REPAIR KIT 235-474

Includes needle, gasket, diffuser/seat.

LINE GUIDE POINTER

Works only with Second Gun and Hose Kit 224-097.

Order One each of the following:

100-538	Screw
181-735	Indicator Holder
181-730	Line Indicator

SLEEVE REMOVAL TOOL 224-787

Required for removing the sleeve of the displacement pump during service.

THROAT SEAL LIQUID

Non-evaporating liquid for the wet-cup. Helps prevent buildup of paint on the rod and throat packings, to reduce premature wear.

DISPLACEMENT PUMP REPAIR Kit 222-588

See contents on page 42. Repair instructions are included with the kit.

206-994	8 oz.
206-995	1 quart
206-996	1 gallon

The Graco Warranty and Disclaimers

WARRANTY

Graco warrants all equipment listed in this manual which is manufactured by Graco and bearing its name to be free from defects in material and workmanship on the date of sale by an authorized Graco distributor to the original purchaser for use. Graco will, for a period of twelve months from the date of sale, repair or replace any part of the equipment determined by Graco to be defective. This warranty applies only when the equipment is installed, operated and maintained in accordance with Graco's written recommendations.

This warranty does not cover, and Graco shall not be liable for general wear and tear, or any malfunction, damage or wear caused by faulty installation, misapplication, abrasion, corrosion, inadequate or improper maintenance, negligence, accident, tampering, or substitution of non-Graco component parts. Nor shall Graco be liable for malfunction, damage or wear caused by the incompatibility of Graco equipment with structures, accessories, equipment or materials not supplied by Graco, or the improper design, manufacture, installation, operation or maintenance of structures, accessories, equipment or materials not supplied by Graco.

This warranty is conditioned upon the prepaid return of the equipment claimed to be defective to an authorized Graco distributor for verification of the claimed defect. If the claimed defect is verified, Graco will repair or replace free of charge any defective parts. The equipment will be returned to the original purchaser transportation prepaid. If inspection of the equipment does not disclose any defect in material or workmanship, repairs will be made at a reasonable charge, which charges may include the costs of parts, labor, and transportation.

THIS WARRANTY IS EXCLUSIVE, AND IS IN LIEU OF ANY OTHER WARRANTIES, EXPRESS OR IMPLIED, INCLUDING BUT NOT LIMITED TO WARRANTY OF MERCHANTABILITY OR WARRANTY OF FITNESS FOR A PARTICULAR PURPOSE.

Graco's sole obligation and buyer's sole remedy for any breach of warranty shall be as set forth above. The buyer agrees that no other remedy (including, but not limited to, incidental or consequential damages for lost profits, lost sales, injury to person or property, or any other incidental or consequential loss) shall be available. Any action for breach of warranty must be brought within two (2) years of the date of sale.

GRACO MAKES NO WARRANTY, AND DISCLAIMS ALL IMPLIED WARRANTIES OF MERCHANTABILITY AND FITNESS FOR A PARTICULAR PURPOSE IN CONNECTION WITH ACCESSORIES, EQUIPMENT, MATERIALS, OR COMPONENTS SOLD BUT NOT MANUFACTURED BY GRACO. These items sold, but not manufactured by Graco (such as electric motors, switches, hose, etc.) are subject to the warranty, if any, of their manufacturer. Graco will provide purchaser with reasonable assistance in making any claim for breach of these warranties.

For Sales to Canadian Customers:

Except as expressly stated herein, Graco makes no representations, warranties or conditions, express, implied or collateral, concerning any goods or services sold, and **GRACO SHALL NOT BE LIABLE IN ANY MANNER FOR** any other representation, warranty or condition of any kind, whether arising by operation of law or otherwise, including but not limited to, **WARRANTIES OF MERCHANTABILITY OR FITNESS FOR A PARTICULAR PURPOSE.**

LIMITATION OF LIABILITY

In no event will Graco be liable for indirect, incidental, special or consequential damages resulting from Graco supplying equipment hereunder, or for the furnishing, performance, or use of any products or other goods sold hereto, whether due to a breach of contract, breach of warranty, the negligence of Graco, or otherwise.

Graco Phone Number

TO PLACE AN ORDER, contact your Graco distributor, or call this number to identify the distributor closest to you:
1-800-367-4023 Toll Free.

All written and visual data contained in this document reflects the latest product information available at the time of publication. Graco reserves the right to make changes at any time without notice.

Sales Offices: Atlanta, Chicago, Detroit, Los Angeles
Foreign Offices: Belgium, Canada, England, Korea, Switzerland, France, Germany, Hong Kong, Japan

GRACO INC. P.O. BOX 1441 MINNEAPOLIS, MN 55440-1441

PRINTED IN U.S.A. 308-105 October 1990, Revised November 1996