

INSTRUCTIONS-PARTS LIST



308-248

Rev A

This manual contains **IMPORTANT INSTRUCTIONS and WARNINGS.**
READ AND RETAIN FOR REFERENCE.

ELECTRIC, 120 VAC

490st AIRLESS PAINT SPRAYER

2750 psi (195 bar) MAXIMUM WORKING PRESSURE

Model 231-208, Series A

Complete sprayer with hose, gun, RAC IV® DripLess™ Tip Guard and SwitchTip™

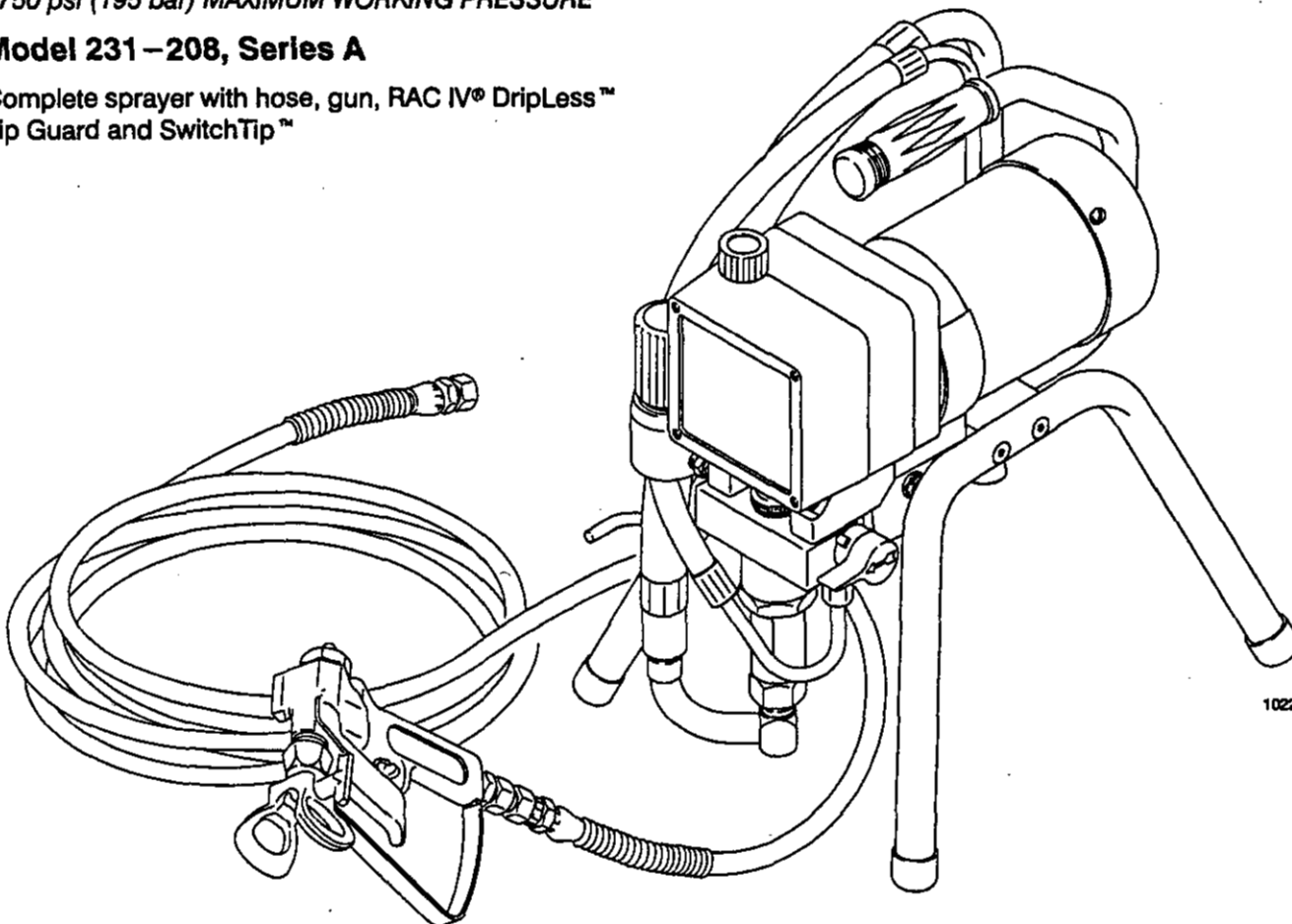

1022

NOTE: This is an example of the DANGER label on your sprayer. This label is available in other languages, free of charge. See page 32 to order.

| ! DANGER ! | | | |
|---|----------------------------------|--|------------------------------|
| | FIRE AND EXPLOSION HAZARD | | SKIN INJECTION HAZARD |
| <p>Spray painting, flushing or cleaning equipment with flammable liquids in confined areas can result in fire or explosion.</p> <p>Use outdoors or in extremely well ventilated areas. Ground equipment, hoses, containers and objects being sprayed.</p> <p>Avoid all ignition sources such as static electricity from plastic drop cloths, open flames such as pilot lights, hot objects such as cigarettes, arcs from connecting or disconnecting power cords or turning light switches on and off.</p> <p>Failure to follow this warning can result in death or serious injury.</p> | | <p>Liquids can be injected into the body by high pressure airless spray or leaks - especially hose leaks.</p> <p>Keep body clear of the nozzle. Never stop leaks with any part of the body. Drain all pressure before removing parts. Avoid accidental triggering of gun by always setting safety latch when not spraying.</p> <p>Never spray without a tip guard.</p> <p>In case of accidental skin injection, seek immediate "Surgical Treatment".</p> <p>Failure to follow this warning can result in amputation or serious injury.</p> | |
| READ AND UNDERSTAND ALL LABELS AND INSTRUCTION MANUALS BEFORE USE | | | |

GRACO INC. P.O. BOX 1441 MINNEAPOLIS, MN 55440-1441

©COPYRIGHT 1992, GRACO INC.

SAFETY WARNINGS

HIGH PRESSURE SPRAY CAN CAUSE SERIOUS INJURY.
FOR PROFESSIONAL USE ONLY. OBSERVE ALL WARNINGS
Read and understand all instruction manuals before operating equipment.

FLUID INJECTION HAZARD

General Safety

This equipment generates very high fluid pressure. Spray from the gun, leaks or ruptured components can inject fluid through your skin and into your body and cause extremely serious bodily injury, including the need for amputation. Also, fluid injected or splashed into the eyes or on the skin can cause serious damage.

NEVER point the spray gun at anyone or at any part of the body. NEVER put hand or fingers over the spray tip. NEVER try to "blow back" paint; this is NOT an air spray system.

ALWAYS have the tip guard in place on the spray gun when spraying.

ALWAYS follow the **Pressure Relief Procedure**, below, before cleaning or removing the spray tip or servicing any system equipment.

NEVER try to stop or deflect leaks with your hand or body.

Be sure equipment safety devices are operating properly before each use.

Medical Alert – Airless Spray Wounds

If any fluid appears to penetrate your skin, get **EMERGENCY MEDICAL CARE AT ONCE. DO NOT TREAT AS A SIMPLE CUT.** Tell the doctor exactly what fluid was injected.

Note to Physician: Injection in the skin is a traumatic injury. It is important to treat the injury surgically as soon as possible. Do not delay treatment to research toxicity. Toxicity is a concern with some exotic coatings injected directly into the blood stream. Consultation with a plastic surgeon or reconstructive hand surgeon may be advisable.

Spray Gun Safety Devices

Be sure all gun safety devices are operating properly before each use. Do not remove or modify any part of the gun; this can cause a malfunction and result in serious bodily injury.

Safety Latch

Whenever you stop spraying, even for a moment, always set the gun safety latch in the closed or "safe" position, making the gun inoperative. Failure to set the safety latch can result in accidental triggering of the gun.

Diffuser

The gun diffuser breaks up spray and reduces the risk of fluid injection when the tip is not installed. Check diffuser operation regularly. Follow the **Pressure Relief Procedure**, below, then remove the spray tip. Aim the gun into a metal pail, holding the gun firmly to the pail. Using the lowest possible pressure, trigger the gun. If the fluid emitted is not diffused into an irregular stream, replace the diffuser immediately.

Tip Guard

ALWAYS have the tip guard in place on the spray gun while spraying. The tip guard alerts you to the fluid injection hazard and helps reduce, but does not prevent, the risk of accidentally placing your fingers or any part of your body close to the spray tip.

Trigger Guard

Always have the trigger guard in place on the gun when spraying to reduce the risk of accidentally triggering the gun if it is dropped or bumped.

Spray Tip Safety

Use extreme caution when cleaning or changing spray tips. If the spray tip clogs while spraying, engage the gun safety latch immediately. ALWAYS follow the **Pressure Relief Procedure** and then remove the spray tip to clean it.

NEVER wipe off build-up around the spray tip until pressure is fully relieved and the gun safety latch is engaged.

Pressure Relief Procedure

To reduce the risk of serious bodily injury, including fluid injection, splashing fluid or solvent in the eyes or on the skin, or injury from moving parts or electric shock, always follow this procedure whenever you shut off the sprayer, when checking or servicing any part of the spray system, when installing, cleaning or changing spray tips, and whenever you stop spraying.

1. Engage the gun safety latch.
2. Turn the ON/OFF switch to OFF.
3. Unplug the power supply cord.

4. Disengage the gun safety latch. Hold a metal part of the gun firmly to the side of a grounded metal pail, and trigger the gun to relieve pressure.
5. Engage the gun safety latch.
6. Open the pressure drain valve, having a container ready to catch the drainage. Leave the valve open until you are ready to spray again.

If you suspect that the spray tip or hose is completely clogged, or that pressure has not been fully relieved after following the steps above, VERY SLOWLY loosen the tip guard retaining nut or hose end coupling to relieve pressure gradually, then loosen completely. Now clear the tip or hose.

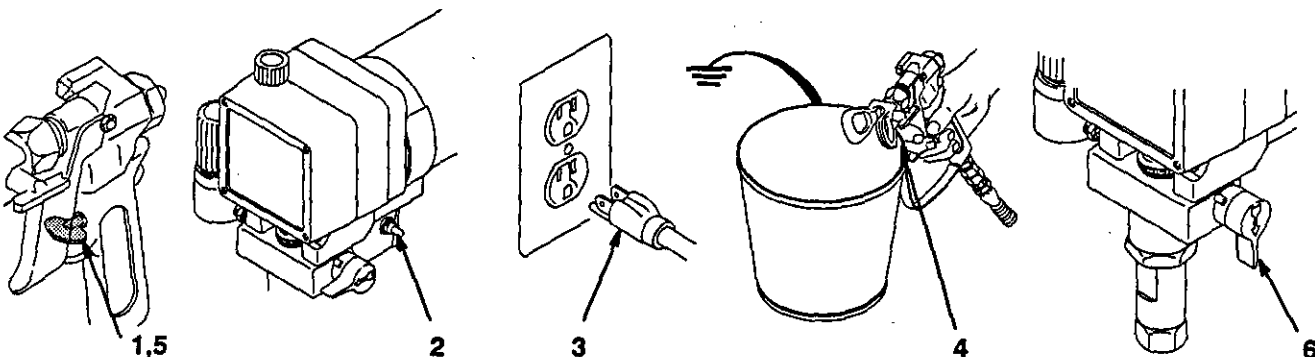

MOVING PARTS HAZARD

Moving parts can pinch or amputate your fingers or other body parts. **KEEP CLEAR** of moving parts when starting or operating the sprayer. Follow the **Pressure Relief Procedure** on page 2 before checking or servicing any part of the sprayer, to prevent it from starting accidentally.

EQUIPMENT MISUSE HAZARD

General Safety

Any misuse of the spray equipment or accessories, such as overpressurizing, modifying parts, using incompatible chemicals and fluids, or using worn or damaged parts, can cause them to rupture and result in fluid injection, splashing in the eyes or on the skin, or other serious bodily injury, or fire, explosion or property damage.

NEVER alter or modify any part of this equipment; doing so could cause it to malfunction.

CHECK all spray equipment regularly and repair or replace worn or damaged parts immediately.

Always wear protective eyewear, gloves, clothing and respirator as recommended by the fluid and solvent manufacturer.

System Pressure

This sprayer can develop **2750 psi (195 bar) MAXIMUM WORKING PRESSURE**. Be sure that all spray equipment and accessories used are rated to withstand this pressure. **DO NOT** exceed the maximum working pressure of any component or accessory used in the system.

Fluid and Solvent Compatibility

BE SURE that all fluids and solvents used are chemically compatible with the wetted parts shown in the **TECHNICAL DATA** on page 32. Always read the fluid and solvent manufacturer's literature before using them in this sprayer.

Do not use 1,1,1-trichloroethane, methylene chloride, other halogenated hydrocarbon solvents or fluids containing such solvents in this equipment, which contains aluminum and/or zinc parts. Such use could result in a serious chemical reaction, with the possibility of explosion, which could cause death, serious bodily injury and/or substantial property damage.

FIRE OR EXPLOSION HAZARD

Static electricity is created by the flow of fluid through the pump and hose. If every part of the spray equipment is not properly grounded, sparking may occur, and the system may become hazardous. Sparking may also occur when plugging in or unplugging a power supply cord. Sparks can ignite fumes from solvents and the fluid being sprayed, dust particles and other flammable substances, whether you are spraying indoors or outdoors, and can cause a fire or explosion and serious bodily injury and property damage. Plug the sprayer into a grounded outlet at least 20 ft. (6 m) from the sprayer.

If you experience any static sparking or even a slight shock while using this equipment, **STOP SPRAYING IMMEDIATELY**. Check the entire system for proper grounding. Do not use the system again until the problem has been identified and corrected.

Grounding

To reduce the risk of static sparking, ground the sprayer and all other spray equipment used or located in the spray area. **CHECK** your local electrical code for detailed grounding instructions for your area and type of equipment. **BE SURE** to ground all of this spray equipment:

1. *Sprayer*: plug into a properly grounded outlet. Do not use an adapter. Extension cords must have three wires and be rated for at least 15 amps.

HOSE SAFETY

High pressure fluid in the hoses can be very dangerous. If the hose develops a leak, split or rupture due to any kind of wear, damage or misuse, the high pressure spray emitted from it can cause a fluid injection injury or other serious bodily injury or property damage.

ALL FLUID HOSES MUST HAVE SPRING GUARDS ON BOTH ENDS! Spring guards help protect the hose from kinks or bends at or close to the coupling which can result in hose rupture.

TIGHTEN all fluid connections securely before each use. High pressure fluid can dislodge a loose coupling or allow high pressure spray to be emitted from the coupling.

NEVER use a damaged hose. Before each use, check the entire hose for cuts, leaks, abrasion, bulging cover, or damage or movement of the hose couplings. If any of these conditions exist, replace the hose immediately. **DO NOT** try to recouple high pressure hose or mend it with tape or any other device. A repaired hose cannot contain the high pressure fluid.

HANDLE AND ROUTE HOSES CAREFULLY. Do not pull on hoses to move equipment. Keep hoses clear of moving parts and hot surfaces of the pump and gas engine. Do not use fluids or solvents which are not compatible with the inner tube and cover of the hose. **DO NOT** expose Graco hose to temperatures above 180° F (82° C) or below -40° F (-40° C).

Hose Grounding Continuity

Proper hose grounding continuity is essential to maintaining a grounded spray system. Check the electrical resistance of your fluid hoses at least once a week. If your hose does not have a tag on it which specifies the maximum electrical resistance, contact the hose supplier or manufacturer for the maximum resistance limits. Use a resistance meter in the appropriate range for your hose to check the resistance. If the resistance exceeds the recommended limits, replace it immediately. An ungrounded or poorly grounded hose can make your system hazardous. Also read **FIRE OR EXPLOSION HAZARD**.

2. *Fluid hoses*: use only grounded hoses with a maximum of 150 m combined hose length to ensure grounding continuity. See **Hose Grounding Continuity**.
3. *Spray gun*: obtain grounding through connection to a properly grounded fluid hose and sprayer.
4. *Object being sprayed*: according to local code.
5. *Fluid supply container*: according to local code.
6. *All solvent pails used when flushing*, according to local code. Use only metal pails, which are conductive. Do not place the pail on a non-conductive surface, such as paper or cardboard, which interrupts the grounding continuity.
7. *To maintain grounding continuity when flushing or relieving pressure*, always hold a metal part of the gun firmly to the side of a grounded metal pail, then trigger the gun.

Flushing Safety

Reduce the risk of fluid injection injury, static sparking, or splashing by following the flushing procedure given on page 13 of this manual. Follow the **Pressure Relief Procedure** on page 2, and remove the spray tip before flushing. Hold a metal part of the gun firmly to the side of a grounded metal pail and use the lowest possible fluid pressure during flushing.

IMPORTANT

United States Government safety standards have been adopted under the Occupational Safety and Health Act. These standards – particularly the General Standards, Part 1910, and the Construction Standards, Part 1926 – should be consulted.

AVERTISSEMENT

La pulvérisation à haute pression peut causer des blessures très graves.
Réservé exclusivement à l'usage professionnel. Observer toutes les consignes de sécurité.
Bien lire et bien comprendre tous les manuels d'instructions avant d'utiliser le matériel.

RISQUES D'INJECTION

Consignes générales de sécurité

Cet appareil produit un fluide à très haute pression. Le fluide pulvérisé par le pistolet ou le fluide sous pression provenant de fuites ou de ruptures peut pénétrer sous la peau ou à l'intérieur du corps et entraîner des blessures très graves, voir même une amputation. Même sans être sous pression, le fluide éclaboussant ou entrant dans les yeux peut aussi entraîner des blessures graves.

NE JAMAIS pointer le pistolet vers quelqu'un ou vers une partie quelconque du corps. NE JAMAIS mettre la main ou les doigts sur l'ajutage du pulvérisateur. NE JAMAIS essayer de "refouler" la peinture. Cet appareil N'est PAS un compresseur pneumatique.

TOUJOURS garder la protection de l'ajutage en place sur le pistolet pendant la pulvérisation.

TOUJOURS observer la **Marche à Sulvre pour Détendre la Pression** donnée plus loin, avant de nettoyer ou d'enlever l'ajutage du pulvérisateur, ou d'effectuer un travail quelconque sur une partie de l'appareil.

NE JAMAIS essayer d'arrêter ou de dévier les fuites avec la main ou le corps.

Avant chaque utilisation, bien s'assurer que les dispositifs de sécurité fonctionnent correctement.

Soins médicaux

En cas de pénétration de fluide sous la peau: **DEMANDER IMMEDIATEMENT DES SOINS MEDICAUX D'URGENCE.** Ne pas soigner cette blessure comme une simple coupure.

Avis au medecin: La pénétration des fluides sous la peau est un traumatisme. **Il est important de traiter chirurgicalement cette blessure immédiatement.** Ne pas retarder le traitement pour effectuer des recherches sur la toxicité. Certains revêtements exotiques sont dangereusement toxiques quand ils sont injectés directement dans le sang. Il est souhaitable de consulter un chirurgien esthétique ou un chirurgien spécialisé dans la reconstruction des mains.

Dispositifs de sécurité du pistolet

Avant chaque utilisation, bien s'assurer que tous les dispositifs de sécurité du pistolet fonctionnent correctement. Ne pas enlever ni modifier une partie quelconque du pistolet; ceci risquerait d'entraîner un mauvais fonctionnement et des blessures graves.

Verrou de sécurité

A chaque fois que l'on s'arrête de pulvériser, même s'il s'agit d'un court instant, toujours mettre le verrou de sécurité du pistolet sur la position "fermée" ou "sécurité" ("safe") pour empêcher le pistolet de fonctionner. Si le verrou de sécurité n'est pas mis, le pistolet peut se déclencher accidentellement.

Diffuser

Le diffuseur du pistolet sert à diviser le jet et à réduire les risques d'injection accidentelle quand l'ajutage n'est pas en place. Vérifier le fonctionnement du diffuseur régulièrement. Pour cette vérification, détendre la pression en observant la **Marche à Sulvre pour Détendre la Pression** donnée plus loin puis enlever l'ajutage du pulvérisateur. Pointer le pistolet dans un seau en métal, en le maintenant fermement contre le seau. Puis, en utilisant la pression la plus faible possible, appuyer sur la gachette du pistolet. Si le fluide projette n'est pas diffusé sous forme de jet irrégulier, remplacer immédiatement le diffuseur.

Protection de l'ajutage

TOUJOURS maintenir la protection de l'ajutage en place sur le pistolet du pulvérisateur pendant la pulvérisation. La protection de l'ajutage attire l'attention sur les risques d'injection et contribue à réduire, mais n'évite pas le risque, que les doigts ou une partie quelconque du corps ne passent accidentellement à proximité immédiate de l'ajutage du pulvérisateur.

Consignes de sécurité concernant l'ajutage du pulvérisateur

Faire extrêmement attention à l'occasion du nettoyage ou du remplacement des ajutages du pulvérisateur. Si l'ajutage se bouche pendant la pulvérisation, mettre immédiatement le verrou de sécurité du pistolet. TOUJOURS bien observer la **Marche à Sulvre pour Détendre la Pression** puis enlever l'ajutage du pulvérisateur pour le nettoyer.

NE JAMAIS essayer ce qui s'est accumulé autour de l'ajutage du pulvérisateur avant que la pression ne soit complètement tombée et que le verrou de sécurité du pistolet ne soit engagé.

Marche à Sulvre pour Détendre la Pression

Pour réduire les risques de blessures graves, y compris les blessures par projection de fluide ou celles causées par de éclaboussures dans les yeux ou sur la peau, par des pièces en mouvement, toujours bien observe cette marche à suivre chaque fois que l'on arrête le pulvérisateur, à l'occasion de la vérification, du égale ou du nettoyage du système ou lors du changement des ajutages.

1. Engager le verrou de sécurité du pistolet.
2. Mettre le levier d'arrêt du moteur sur ARRET (OFF).
3. Débrancher le cord d'alimentation.

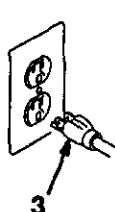
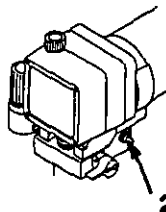

4. Désengager le verrou de sécurité du pistolet. Tout en maintenant une partie métallique du pistolet fermement appuyé contre le côté d'un seau en métal, actionner le pistolet pour libérer la pression.
5. Engager le verrou de sécurité du pistolet.
6. Ouvrir la soupape de sécurité et la laisser ouverte jusqu'à ce que l'on soit prêt à se servir de nouveau du pulvérisateur.

Si l'on soupçonne que le tuyau ou l'ajutage est complètement bouché ou que la pression n'a pas été complètement libérée après avoir procédé aux opérations ci-dessus, desserrer TRES LENTEMENT un raccord de bout de tuyau ou l'écrou de retenue de la protection de l'ajutage et libérer progressivement la pression.

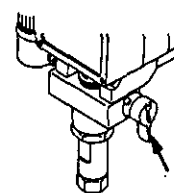

0480

RISQUES EN CAS DE MAUVAISE UTILISATION DU MATERIEL

Consignes générales de sécurité

Toute utilisation anormale de l'appareil de pulvérisation ou des accessoires comme, par exemple, la mise sous une pression excessive, les modifications de pièces, l'utilisation de produits chimiques et de matières incompatibles et l'utilisation de pièces usées ou abîmées peut causer des dégâts à l'appareil ou des ruptures de pièces et entraîner une injection de liquide ou d'autres blessures sérieuses, un incendie, une explosion ou d'autres dégâts.

Ne Jamais altérer ou modifier une pièce de cet appareil; ceci risquerait d'entraîner son mauvais fonctionnement.

Vérifier régulièrement tout l'appareil de pulvérisation et ses équipements et réparer ou remplacer immédiatement les pièces usées ou abîmées.

MESURES DE SÉCURITÉ CONCERNANT LES TUYAUX FLEXIBLES

Le fluide à haute pression circulant dans les tuyaux peut être très dangereux. En cas de fuite sur le tuyau, de fissure, déchirure ou rupture à la suite de l'usure, de dégâts ou d'une mauvaise utilisation, les projections de fluide haute pression qui en proviennent peuvent entraîner des blessures graves par pénétration sous la peau ou par contact, ainsi que des dégâts matériels.

Tous les tuyaux flexibles doivent avoir des ressorts spirale de protection aux bouts! Les spirales de protection contribuent à éviter la formation de pliures, de boucles ou de nœuds sur les tuyaux qui pourraient entraîner la rupture du tuyau à l'endroit du raccord ou à son voisinage.

Serrer fermement tous les raccords avant chaque utilisation. Le fluide sous pression peut faire sauter un raccord desserré ou produire un jet à haute pression s'échappant par le raccord.

Ne Jamais utiliser un tuyau endommagé. Ne Pas essayer de refaire le raccord d'un tuyau haute pression ni de réparer le tuyau avec du ruban adhésif ou par tout autre moyen. Un tuyau réparé ne peut pas résister au fluide sous pression.

RISQUES D'INCENDIE OU D'EXPLOSION

De l'électricité statique est produite par le passage du fluide à grande vitesse dans la pompe et dans les tuyaux. Si toutes les pièces de l'appareil de pulvérisation ne sont pas convenablement reliés à la masse ou à la terre, des étincelles peuvent se produire et l'appareil risque d'être dangereux. Des étincelles peuvent également se produire à l'occasion du branchement ou du débranchement du cordon d'alimentation. Les étincelles sont suffisantes pour allumer les vapeurs de solvants et le fluide pulvérisé, les fines particules de poussière ainsi que d'autres substances inflammables, et elles peuvent causer un incendie ou une explosion, ainsi que des blessures graves et des dégâts matériels. Toujours brancher le pulvérisateur dans une prise se trouvant à au moins 6 m (20 pieds) de l'appareil et de l'endroit où se fait la pulvérisation.

S'il se produit des étincelles d'électricité statique, ou si vous sentez la moindre décharge, **ARRÊTEZ IMMÉDIATEMENT LA PULVÉRISATION**. Vérifiez que le système entier est bien mis à la terre. Ne vous servez pas du système avant que le problème soit identifié et corrigé.

Mise à la terre ou à la masse

Pour réduire les risques de production d'étincelles d'électricité statique, le pulvérisateur et tous les équipements utilisés ou se trouvant dans la zone de pulvérisation doivent être reliés à la terre ou à la masse. Pour connaître le détail des instructions de mise à la terre dans la région et le type particulier d'équipement, **CONSULTER** le code ou les réglementations électriques locales. **S'ASSURER** que tous les équipements de pulvérisation suivants sont bien reliés à la terre:

1. **Pulvérisateur:** Brancher le cordon d'alimentation ou la rallonge qui doivent être équipés d'une prise à 3 fiches en bon état, dans une prise de courant convenablement mise à la terre. Ne pas utiliser d'adaptateur. Toutes les rallonges doivent avoir 3 fils et être prévues pour 15 ampères.

Pression

Ce pulvérisateur peut produire une **PRESSIION MAXIMUM DE TRAVAIL 195 bar (2750 lb/po2)**. S'assurer que tous les éléments du pulvérisateur et ses accessoires sont conçus pour résister à la pression maximum de travail de ce pulvérisateur. **NE PAS** dépasser la pression maximum de travail d'aucun des éléments ou accessoires utilisés avec cet appareil.

Compatibilité chimique des corps

Bien s'Assurer que tous les corps des solvants utilisés sont chimiquement compatibles avec les parties mouillées indiquées dans les **Technical Data**, à page 32. Toujours lire soigneusement les documents et brochures du fabricant des fluides et solvants utilisés avant de s'en servir dans ce pulvérisateur.

Manipuler les tuyaux avec précaution et choisir soigneusement leur chemin. Ne pas déplacer le fluide en tirant sur le tuyau. Ne pas utiliser de fluides ou de solvants qui ne sont pas compatibles avec l'enveloppe intérieure ou extérieure du tuyau. **NE PAS** exposer le tuyau à des températures supérieures à 82°C (180° F) ou inférieures à -40° C (-40° F).

Continuité de la mise à la terre des tuyaux

Une bonne continuité de la mise à la terre des tuyaux est essentielle pour maintenir la mise à la terre de l'ensemble de vaporisation. Vérifiez la résistance électrique de vos tuyaux à fluides et à air, au moins une fois par semaine. Si votre tuyau ne comporte pas d'étiquette qui précise la résistance électrique maximum, prenez contact avec le fournisseur de tuyaux ou le fabricant pour avoir les limites de résistance maximum. Utilisez un mètre de résistance de la gamme appropriée pour votre tuyau et vérifiez la résistance. Si celle-ci dépasse les limites recommandées, remplacez le tuyau immédiatement. Un tuyau sans mise à la terre ou avec une mise à la terre incorrecte peut entraîner des risques pour votre système. Lisez aussi **LES RISQUES D'INCENDIE OU D'EXPLOSION** ci-dessus.

2. **Tuyaux flexibles:** Afin d'assurer la continuité de la mise à la terre, n'utiliser que des tuyaux comportant une mise à la terre et ayant une longueur maximum combinée de 150 m (1500 pieds). Se reporter également au paragraphe **Continuité du circuit de mise à la terre des tuyaux**.
3. **Pistolet:** Réaliser la mise à la terre en le raccordant à un tuyau flexible et à un pulvérisateur déjà convenablement reliés à la terre.
4. **Réceptacle d'alimentation:** observer le code ou les réglementations locales.
5. **Objets, matériel ou surfaces recevant la pulvérisation:** observer le code ou les réglementations locales.
6. **Tous les seaux de solvants** utilisés pour le rinçage: observer le code ou les réglementations locales. N'utiliser que des seaux métalliques conducteurs de l'électricité. Ne pas mettre le seau sur une surface non conductrice comme sur du papier ou du carton car cela interromprait la continuité de la mise à la terre.
7. **Pour conserver la continuité de la mise à la terre quand on rince le matériel ou quand on libère la pression**, toujours maintenir une partie métallique du pistolet fermement appuyée contre le côté d'un seau en métal puis appuyer sur la détente du pistolet.

Mesures de sécurité concernant le rinçage

Pour réduire les risques de blessures par pénétration de la peau et les risques dus aux étincelles d'électricité statique ou aux éclaboussures, observer la marche à suivre pour le rinçage donnée à la page 13 de ce manuel. Observer la "Marche à Suivre pour Détendre la Pression" donnée à la page 4 en **enlever l'ajutage du pulvérisateur avant le rinçage**. Maintenir une partie métallique du pistolet fermement appuyée contre le côté d'un seau en métal et utiliser la pression la plus faible possible pendant le rinçage.

ADVERTENCIA

EL ROCIADO a ALTA PRESIÓN PUEDE CAUSAR GRAVES LESIONES.
SOLO PARA USO PROFESIONAL. RESPETE LOS AVISOS DE ADVERTENCIA.

Lea y entienda todo el manual de instrucciones antes de manejar el equipo.

PELIGRO DE INYECCIÓN DE FLUIDO

Seguridad general

Este equipo genera un fluido a una presión muy alta. El rociado de la pistola, los escapes de fluido o roturas de los componentes pueden inyectar fluido en la piel y el cuerpo y causar lesiones extremadamente graves, incluyendo a veces la necesidad de amputación. También, el fluido inyectado o salpicado en los ojos puede causar graves daños.

NUNCA apuntar la pistola hacia alguien o alguna parte del cuerpo. NUNCA colocar la mano o los dedos encima de la boquilla. NUNCA tratar de "hacer retornar la pintura"; este NO es un sistema de rociado de aire.

SIEMPRE tener colocado el protector de la boquilla en la pistola mientras se está pulverizando.

SIEMPRE seguir el procedimiento de descarga de presión, dado más abajo, antes de limpiar o sacar la boquilla o de dar servicio a cualquier equipo del sistema.

NUNCA tratar de parar o desviar los escapes con la mano o el cuerpo.

Asegurar que todos los aparatos de seguridad del equipo están funcionando bien antes de cada uso.

Tratamiento médico

Si pareciera que un poco de fluido penetró la piel, conseguir **TRATAMIENTO MÉDICO DE URGENCIA DE INMEDIATO. NO TRATAR LA HERIDA COMO UN SIMPLE CORTE.** Decir al médico exactamente cual fluido fue.

Aviso al médico: Si se llega a inyectar este fluido en la piel se causa una lesión traumática. **Es importante tratar quirúrgicamente la lesión a la brevedad posible.** No demorar el tratamiento para investigar la toxicidad. La toxicidad es algo de suma importancia en algunas pinturas exóticas cuando se inyectan directamente al torrente sanguíneo. Será conveniente consultar a un especialista en cirugía plástica o reconstructiva de las manos.

Aparatos de seguridad de la pistola pulverizadora

Asegurar que todos los aparatos protectores de la pistola están funcionando bien antes de cada uso. No sacar ni modificar ninguna pieza de la pistola pues podría causar el malfuncionamiento de la misma con las consiguientes lesiones personales.

Pestillo de seguridad

Cada vez que se deje de pulverizar, aunque sea por un breve momento, siempre colocar el pestillo de seguridad en la posición "cerrada" lo que deja la pistola inoperante. El no hacerlo puede llevar al disparo imprevisto de la pistola.

Difusor

El difusor de la pistola dispersa el chorro pulverizado y reduce el riesgo de inyección cuando no está instalada la boquilla. Revisar con regularidad el funcionamiento del difusor. Seguir el **procedimiento de descarga de presión**, dado más abajo, y después sacar la boquilla. Apuntar la pistola a un balde metálico, sosteniéndola bien firme contra el. Utilizando la presión más bajo posible, disparar la pistola. Si el fluido emitido no sale disperso en un chorro irregular, reemplazar de inmediato el difusor.

Protector de la boquilla

SIEMPRE tener el protector de la boquilla colocado en la pistola mientras se está pulverizando. Este protector llama la atención contra el peligro de inyección y ayuda a reducir, pero no evita, la colocación accidental de los dedos o cualquier otra parte del cuerpo cerca de la boquilla.

Seguridad de la boquilla pulverizadora

Tener mucho cuidado al limpiar o cambiar las boquillas. Si llega a obstruirse mientras está pulverizando, enganchar el pestillo de la pistola de inmediato. SIEMPRE seguir el **procedimiento de descarga de presión** y después sacar la boquilla para limpiarla.

NUNCA limpiar la acumulación de pintura alrededor de la boquilla antes de que se haya descargado por completo la presión y el pestillo este enganchado.

Procedimiento de descarga de presión

Para reducir el riesgo de sufrir graves lesiones corporales, incluyendo inyección o lesiones causadas por piezas en movimiento o choque eléctrico, siempre seguir este procedimiento al apagar la máquina pulverizadora, al revisar o dar servicio a cualquier parte del sistema de pulverización, al instalar, limpiar o cambiar las boquillas, y cada vez que se deja de pulverizar.

1. Enganchar el pestillo de la pistola.
2. Mover el interruptor eléctrico (ON/OFF) a la posición OFF (apagado).
3. Desenchar el cordón eléctrico.

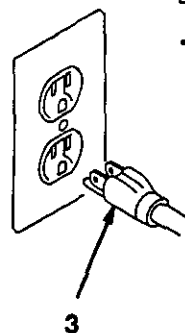
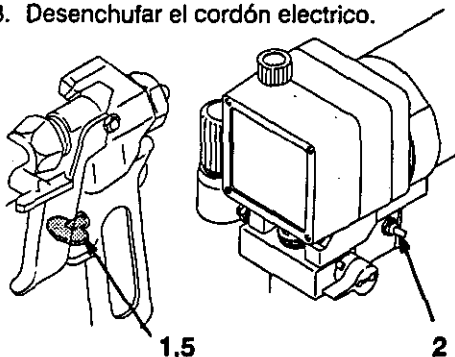

4. Desenganchar el pestillo de la pistola. Sujetar una parte metálica de la pistola bien firme contra un balde de metal, y disparar la pistola para descargar la presión.
5. Enganchar el pestillo de la pistola.
6. Abrir la válvula de presión. Dejar la válvula de alivio de presión abierta hasta que se este nuevamente listo para pulverizar.

Si se sospecha que la boquilla o la manguera está completamente obstruida, o que no se ha descargado por completo la presión después de haber seguido el procedimiento anterior, aflojar muy lentamente la tuerca de retención del protector de la boquilla o acoplamiento de la punta de la manguera y descargar gradualmente la presión, después, aflojarlo por completo. Luego, despejar la boquilla o la manguera.

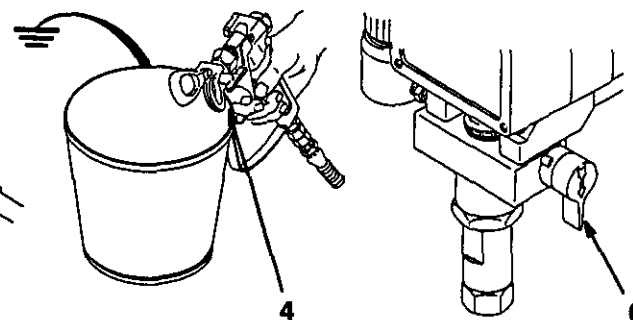

PELIGRO POR MAL USO DEL EQUIPO

Seguridad general

Cualquier mal uso del equipo pulverizador o los accesorios, tal como sobre presurización, modificación de piezas, uso de materiales y productos químicos incompatibles, o utilización de piezas dañadas o desgastadas, pueden hacer que se rompan y causen la inyección de fluido u otras lesiones corporales graves, incendio, explosión o daño a la propiedad.

NUNCA alterar o modificar ninguna pieza de este equipo; el hacerlo podría causar una avería.

REVISAR con regularidad el equipo pulverizador y reparar o reemplazar de inmediato las piezas dañadas o desgastadas.

SEGURIDAD EN EL USO DE LAS MANGUERAS

El fluido que escapa a alta presión por las mangueras puede ser muy peligroso. Si en la manguera se desarrolla un escape, una rotura o rajadura debido a cualquier tipo de desgaste, daño o maltrato, el chorro a alta presión emitido por allí puede causar una lesión por inyección u otras lesiones corporales graves o daños a la propiedad.

¡TODAS LAS MANGUERAS PARA FLUIDOS TIENEN QUE TENER GUARDAS DE RESORTE EN AMBOS EXTREMOS! Estas protegen las mangueras contra dobleces o retorcidas en los acoplamientos o cerca de ellos, los que podrían traducirse en roturas de la manguera.

Antes de usarlas, **APRETAR** bien firmes todas las conexiones. El fluido a alta presión puede desalojar un acoplamiento suelto o dejar que por el escape un chorro a alta presión.

NUNCA usar una manguera que está dañada. Siempre, revisarla en busca de cortaduras, escapes, abrasión, cubierta abultada, o acoplamientos sueltos o dañados. Si llegara a encontrarse cualquiera de estas condiciones, reemplazar de inmediato la manguera. **NO** intentar racoplar una manguera de alta presión o enmendarla con cinta adhesiva u otro material similar. Una manguera que ha sido remendada no aguante el fluido a alta presión.

PELIGRO DE INCENDIO O EXPLOSION

El flujo a alta velocidad del fluido al pasar por la bomba y manguera crea electricidad estática. Si todas las partes del equipo pulverizador no tienen buena tierra, pueden ocurrir chispas, convirtiendo al sistema en algo peligroso. También, pueden producirse chispas al enchufar o desenchufar el cordón eléctrico. Estas chispas pueden inflamar los vapores de los solventes y el chorro de fluido pulverizado, partículas de polvo y otras sustancias inflamables, sea al aire libre o bajo techo, lo que podría causar una explosión o incendio y graves lesiones corporales y daños a la propiedad. Enchufar siempre la pulverizadora a un tomacorriente que se encuentre a por lo menos 6 m (20 pies) de la máquina y del área que se va a rociar.

Si ocurre una chispa de electricidad estática o incluso un ligero choque eléctrico mientras se usa el equipo, **DEJAR DE PULVERIZAR DE INMEDIATO**. Revisar todo el sistema en busca de una tierra apropiada. No usar de nuevo el sistema hasta haber identificado y solucionado el problema.

Puesta a tierra

Para reducir el riesgo de chispas estáticas, conectar a tierra la pulverizadora y todo el otro equipo de pulverizar que se use o se encuentre en el lugar que se va a rociar. **CONSULTAR** el código eléctrico de la localidad para las instrucciones sobre las conexiones a tierra exigidas para la zona y tipo de equipo. **ASEGURAR** de conectar a tierra todo este equipo pulverizador:

1. **Pulverizadora:** enchufar el cordón eléctrico, o cable extensor, cada uno en un enchuf de tres patas en buen estado, a un tomacorriente con puesta a tierra apropiada. No usar un adaptador. Todos los cables extensores tienen que tener tres hilos y una capacidad de 15 amperios.

Presión del sistema

Está pulverizadora puede desarrollar 195 barías (2750 psi) de presión **DE TRABAJO MÁXIMA**. Asegurar que todo el equipo pulverizador y sus accesorios tienen la capacidad para aguantar la presión máxima de trabajo de esta pulverizadora. **NO** exceder la presión máxima de trabajo de ningún componente o accesorio de este sistema.

Compatibilidad de fluido

Siempre leer las instrucciones del fabricante del fluido y solvente antes de usarlos en esta pulverizadora, dadas en la página 32.

Siempre usar gafas, guantes, vestimentas protectora y un respiradero, tal como recomiendan los fabricantes del fluido y del solvente.

MANEJAR Y PASAR CUIDADOSAMENTE LAS MANGUERAS. No tirar de las mangueras para mover el equipo. No usar fluidos o solventes que sean incompatibles con el tubo interno y la cubierta de la manguera. **NO** exponer las mangueras a temperaturas sobre 82° C (180° F) o bajo -40° C (-40° F).

Continuidad del circuito de puesta a tierra de la manguera

La continuidad del circuito de puesta a tierra apropiado es esencial para mantener conectado a tierra el sistema pulverizador. Es indispensable revisar la resistencia eléctrica máxima de las mangueras de aire y de fluido por lo menos una vez a la semana. Si la manguera no tiene una etiqueta en la cual se especifica la resistencia eléctrica, ponerse en contacto con el proveedor o fabricante de la manguera para la información sobre los límites de resistencia. Usar un metro de resistencia en la gama apropiada para comprobar la resistencia; si excede los límites recomendados, reemplazarla de inmediato. Es muy arriesgado tener una manguera sin puesta a tierra o con la puesta a tierra en malas condiciones. Leer también la información sobre **RIESGO DE INCENDIO O EXPLOSION**, más arriba.

2. **Mangueras para fluidos:** usar solamente mangueras con puesta a tierra de una longitud combinada de 150 m (500 pies), para asegurar buena continuidad a tierra. Referirse también al párrafo sobre continuidad a tierra de la manguera.
3. **Pistola:** hacer la puesta a tierra conectándola a una manguera de fluido y pulverizadora bien conectadas a tierra.
4. **Suministrar un recipiente:** de acuerdo al código de la localidad.
5. **Objeto que se está rociando:** de conformidad con el código local.
6. **Todos los baldes de solvente** usados durante el lavado, de conformidad con el código local. Usar **solamente baldes de metal**, que sean conductivos. No colocar el balde en una superficie no conductiva, como papel o cartón, que interrumpe la continuidad a tierra.
7. **Para mantener la continuidad a tierra durante el lavado o descarga de presión**, siempre apoyar una parte metálica de la pistola bien firme contra el costado del **balde de metal**, después apretar el gatillo.

Seguridad durante el lavado

Para reducir el riesgo de que se inyecte o salpique fluido en la piel, o que ocurra una descarga de electricidad estática, siempre seguir las **INSTRUCCIONES PARA EL LAVADO**, dadas en la página 13. Seguir el **procedimiento de descarga de presión** en la página 6, y quitar la **boquilla rociadora antes de lavar**. Apoyar una parte metálica de la pistola bien firme contra el costado de un **balde de metal** y usar la presión más baja posible de fluido durante el lavado.

SETUP

WARNING

If you supply your own hoses and spray gun, be sure the hoses are electrically conductive, that the gun has a tip guard, and that each part is rated for at least 2750 psi (195 bar) Working Pressure. This is to reduce the risk of serious bodily injury caused by static sparking, fluid injection or over-pressurization and rupture of the hose or gun.

CAUTION

To avoid damaging the pressure control, which may result in poor equipment performance and component damage, follow these precautions:

1. Always use nylon spray hose at least 50 ft. (6 m) long.
2. Never use a wire braid hose as it is too rigid to act as a pulsation dampener.
3. Never install any shutoff device between the pump and the hose. See Fig 1.

1. **Connect the hose and gun** and screw it onto the outlet nipple. *Don't use thread sealant, and don't install the spray tip yet!*
2. **Fill the wet-cup.** Pry off the wet-cup seal. Fill the cup 1/3 full with Graco Throat Seal Liquid (TSL), supplied. Install the seal.

3. **Check the electrical service.** Be sure it is 120 V, 60 HzAC, 15 Amp (minimum). Use a properly grounded outlet. Do not remove the third (grounding) prong of the power supply cord, and do not use an adapter.

Use a 3-wire, 12 ga (minimum), 15 amp extension cord up to 150 ft. (45 m) long. Longer lengths affect sprayer performance.

4. **Plug in the sprayer.** Be sure the ON/OFF switch is OFF. Plug the cord into a grounded outlet at least 20 ft. (6 m) away from the spray area.

WARNING

Proper electrical grounding is essential to reduce the risk of fire or explosion which can result in serious bodily injury and property damage. Also read **FIRE OR EXPLOSION HAZARD** on page 3.

5. **Flush the pump** to remove the oil which was left in to protect pump parts after factory testing. See page 13.
6. **Prepare the paint** according to the manufacturer's recommendations. Remove any paint skin. Stir the paint to mix pigments. Strain the paint through a fine nylon mesh bag (available at most paint dealers) to remove particles that could clog the gun filter or spray tip. This is an important step toward trouble-free paint spraying.

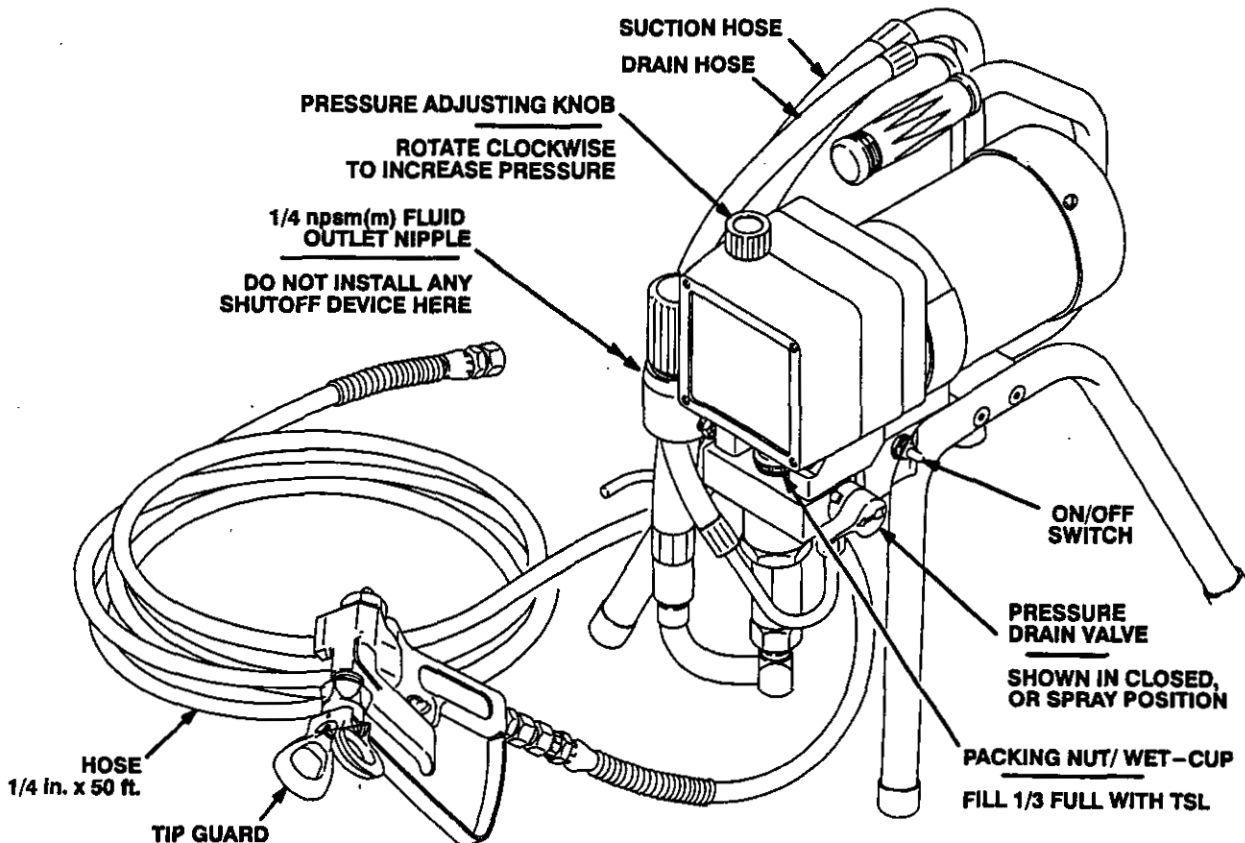

Fig 1

OPERATION

How to use the gun safety latch

When engaged, the gun safety latch prevents the gun from accidental triggering. See Fig 2.

WARNING

If the gun still sprays when the gun safety latch is engaged, adjust the gun. See manual 307-614, supplied.

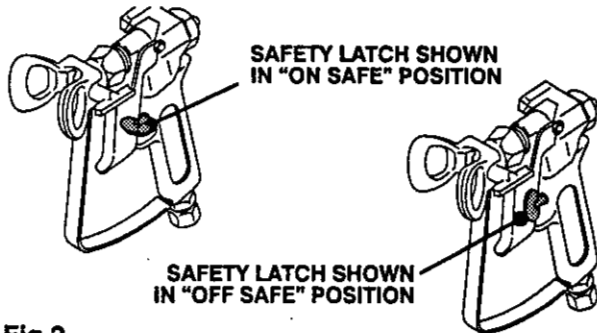

Fig 2

How to use the pressure drain valve

Use the pressure drain valve to relieve fluid pressure from the pump and to help prime the pump. If the valve senses an over pressure condition, it opens automatically to relieve fluid pressure. If this happens, stop spraying immediately, shut off and unplug the sprayer. Determine the cause of the problem and correct it before operating the sprayer again. Refer also to the Troubleshooting Guide, page 14. See Fig 3.

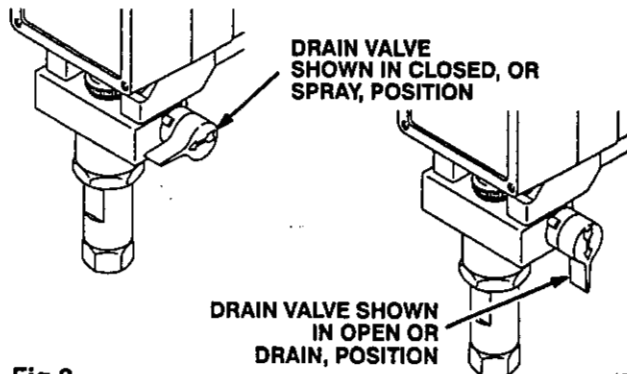

Fig 3

1022

How to use the pressure control

The pressure control controls the motor operation so the sprayer maintains constant fluid pressure at the pump outlet. Turn the pressure control knob fully counterclockwise to obtain the minimum setting. Turn the knob clockwise to increase pressure. See Fig 4.

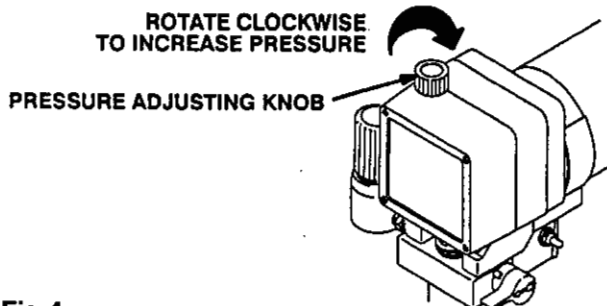

Fig 4

How to use the RAC IV tip guard

WARNING

To reduce the risk of serious bodily injury from fluid injection:

NEVER operate the spray gun with the tip guard removed.

DO NOT hold your hand, body, or a rag in front of the spray tip when cleaning or checking a clogged tip. Always point the gun toward the ground or into a pail when checking to see if the tip is clear.

DO NOT try to "blow back" paint; this is NOT an air spray sprayer.

The tip guard alerts you to the risk and helps prevent placing any part of the body close to the spray tip. The tip guard also adjusts the vertical or horizontal spray pattern. See page 11. The tip guard holds a reversing spray tip. The tip is in the spraying position when the tip handle points forward. See Fig 5.

Clean the front of the tip frequently during the day's operation. First, follow the **Pressure Relief Procedure Warning** on page 2.

HANDLE SHOWN IN SPRAYING POSITION.

TURN HANDLE 180°, TRIGGER GUN TO CLEAR CLOG

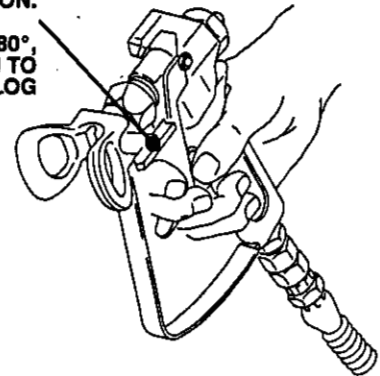

Fig 5

0484

How to remove a tip clog

1. Release the gun trigger. Engage the safety latch. Rotate the RAC IV tip handle 180°. See Fig 5.
2. Disengage the safety latch. Trigger the gun into a pail or onto the ground to remove the clog.
3. Engage the safety latch. Rotate the tip handle to the spraying position.
4. If the tip is still clogged, engage the safety latch, shut off and unplug the sprayer, and open the pressure drain valve to relieve pressure. Clean the spray tip as shown in manual 307-848, supplied.

WARNING

Pressure Relief Procedure

To reduce the risk of serious bodily injury, including fluid injection, splashing fluid or solvent in the eyes or on the skin, or injury from moving parts or electric shock, always follow this procedure when you shut off the sprayer, check or service any part of the spray system, install, clean or change spray tips, and whenever you stop spraying.

- 1 Engage the gun safety latch.
- 2 Turn the ON/OFF switch to OFF.
- 3 Unplug the sprayer.
- 4 Disengage the gun safety latch. Hold a metal part of the gun firmly to the side of a grounded metal pail. Trigger the gun to relieve pressure.
- 5 Engage the gun safety latch.
- 6 Open the pressure drain valve. Leave it open until you are ready to spray again.

If you suspect that the spray tip or hose is completely clogged, or that pressure has not been fully relieved after following the steps above, VERY SLOWLY loosen the tip guard retaining nut or hose coupling to relieve pressure gradually, then loosen completely.

Use this procedure each time you start the sprayer to help ensure the sprayer is ready to operate and that you start it safely.

NOTE 1: If this is a first-time startup, flush the sprayer. See page 13.

NOTE 2: Refer to Fig 9 and the other figures referenced in the text as you start the sprayer.

1. Open the pressure drain valve. See Fig 6.
2. Don't install the spray tip until the pump is primed!

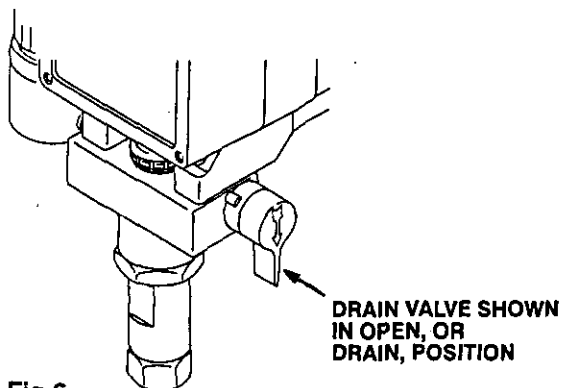

Fig 6

1022

3. Put the suction hose into the paint. If you are pumping from a 1 gallon pail, push the drain hose down below the top of the pail to avoid splashing paint when the drain valve is opened.
4. Turn the pressure setting to minimum.
5. Disengage the gun safety latch. See Fig 2, page 9.

CAUTION

To reduce the risk of damage to the displacement pump packings, never run the pump without fluid in it for more than 30 seconds.

6. To prime the pump, turn the sprayer on. Slowly increase the pressure until the sprayer starts. When fluid comes from the pressure drain valve, close the valve.

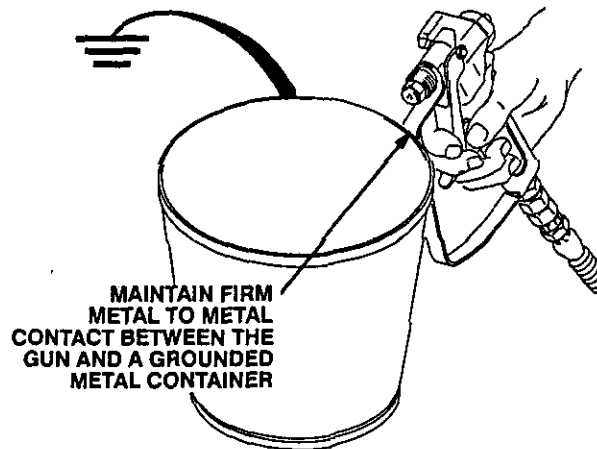

Fig 7

7. To prime the hose, lower the pressure to reduce splashing. Hold a metal part of the gun firmly against and aimed into the side of a grounded metal pail. See Fig 7. Hold the trigger open and slowly increase the pressure until the pump starts. Keep the gun triggered until all air is forced out of the system and the fluid flows freely from the gun. Release the trigger and engage the gun safety latch.
8. Check all fluid connections for leaks. Relieve pressure before tightening any connections.
9. Install the spray tip. Engage the gun safety latch first! See manual 307-848 for how to install the tip.

10. Adjust the spray pattern

- a. Increase the pressure just until spray from the gun is completely atomized. To avoid excessive overspray and fogging, and to extend tip and sprayer life, always use the lowest pressure needed to get the desired results.
- b. If more coverage is needed, use a larger tip rather than increasing the pressure.
- c. Test the spray pattern. To adjust the direction of the spray pattern, engage the gun safety latch and loosen the retaining nut. Position the tip guard horizontally for a horizontal pattern or vertically for a vertical pattern. Hold the tip guard in place while tightening the retaining nut. See Fig 8.

NOTE 3: Spray patterns will change as tips wear. Change the spray tip if adjusting the pressure will not improve the spray pattern.

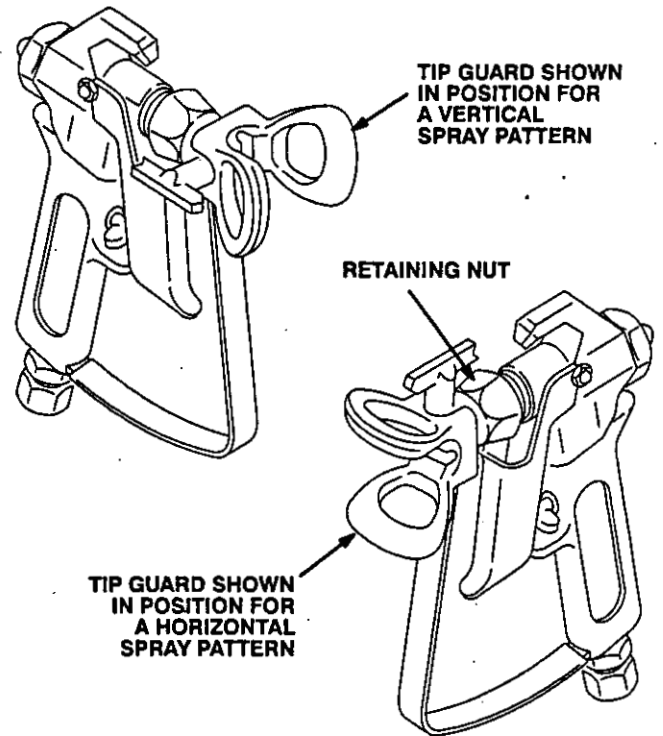

Fig 8

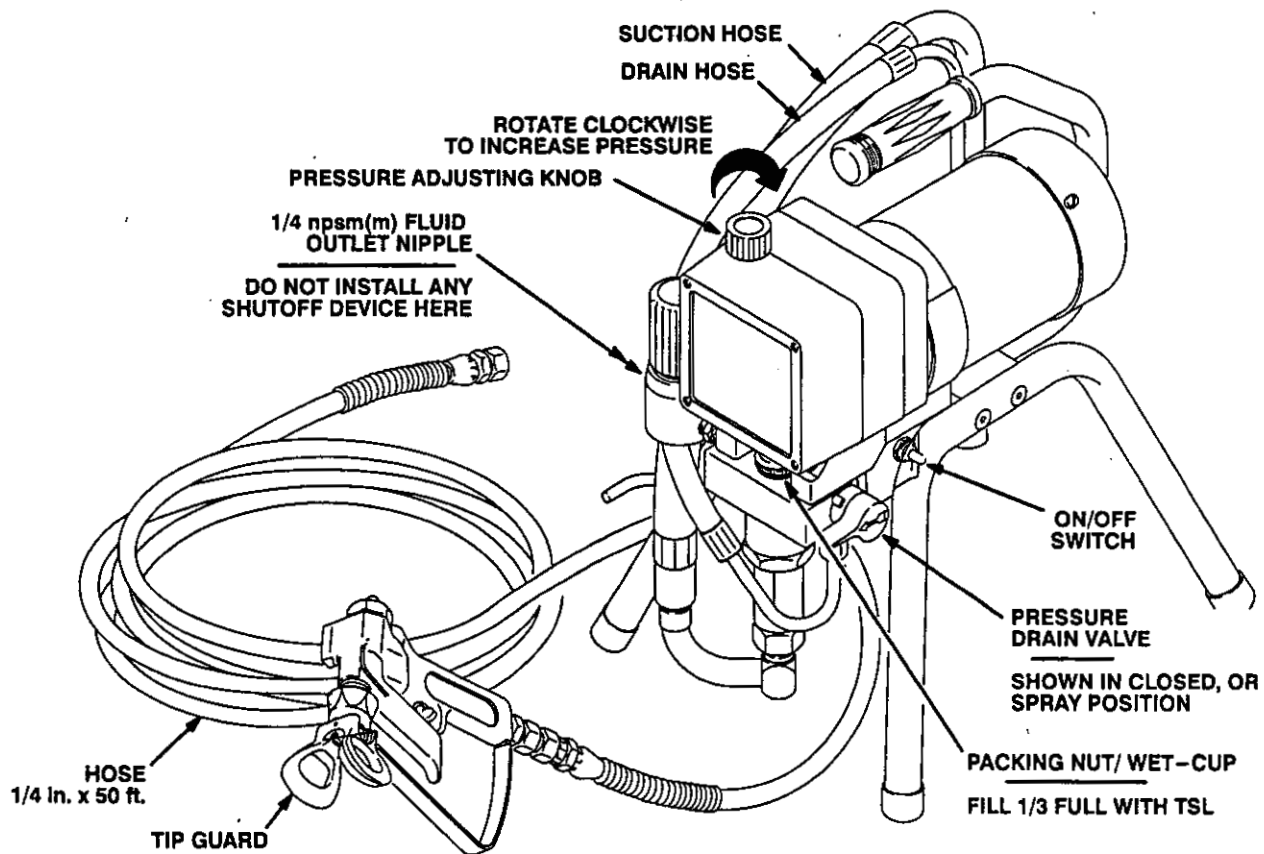

Fig 9

1022

SHUTDOWN AND CARE

WARNING

To reduce the risk of serious bodily injury, always follow the **Pressure Relief Procedure Warning** on page 2 when instructed in this procedure to relieve pressure.

1. **Check the packing nut/wet-cup daily.** Relieve pressure first. Keep the wet-cup 1/3 full of TSL at all times to help prevent fluid buildup on the piston rod and premature wear of packings.
2. **Tighten the packing nut/wet-cup just enough to stop leakage.** Over-tightening causes binding and excessive packing wear. Use a round punch or brass rod and a light hammer to adjust the nut. See Fig 10.
3. **Clean the gun's fluid filter often** and whenever the gun is stored. Relieve pressure first. Refer to manual 307-614.
4. **Periodically clean paint residue from the pressure transducer vent hole area.** See Fig 11. Replace the transducer when leakage is excessive. See page 27.
5. **Lubricate the bearing housing** after every 100 hours of operation. Remove the front cover. Fill the bearing housing cavity with SAE 10 non-detergent oil. See Fig 11.
6. **Flush the sprayer at the end of each work day** and fill it with mineral spirits to help prevent pump corrosion and freezing. See page 13.

CAUTION

To prevent pump corrosion, and to reduce the chance of fluid freezing in the pump in cold weather, never leave water or any type of paint in the sprayer when it is not in use. Freezing can seriously damage the sprayer or result in a loss of pressure or stalling.

7. **For very short shutoff periods,** leave the suction hose in the paint, relieve pressure, and clean the spray tip.
8. **Coil the hose** when storing it, even for overnight, to help protect the hose from kinking, abrasion, coupling damage, etc.

WARNING

See the warning section, **HOSE SAFETY**, on page 3, for information on the hazard of using damaged hoses.

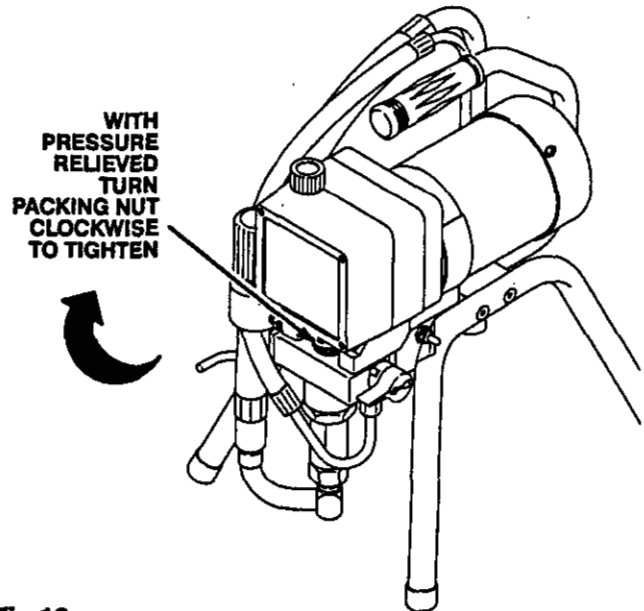

Fig 10

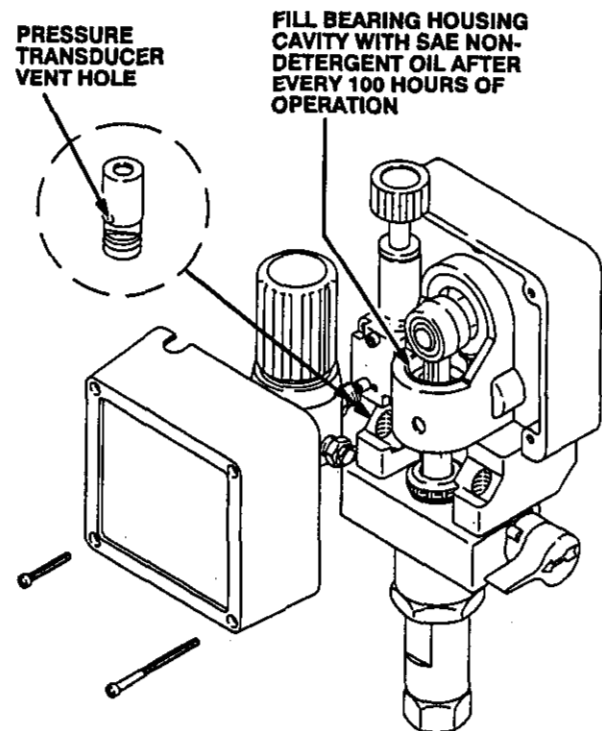

Fig 11

1087

FLUSHING GUIDELINES

When to flush

1. **Before using a new sprayer:** flush out the oil which was left in to protect pump parts.
Before using water-base paint: flush with mineral spirits followed by soapy water, and then a clean water flush.
Before using oil-base paint: flush with mineral spirits only.
2. **Changing colors:** flush with a compatible solvent such as mineral spirits or water.
3. **Changing from water-base to oil-base paint:** flush with warm, soapy water, and then mineral spirits.
4. **Changing from oil-base to water-base paint:** flush with mineral spirits, then warm, soapy water, and then a clean water flush.
5. **Storage after using water-base paint:** flush with water and then mineral spirits. Leave the system filled with mineral spirits. Relieve pressure. Leave the drain valve open.
Storage after using oil-base paint: flush with mineral spirits. Relieve pressure. Leave the drain valve open.

CAUTION

NEVER leave water or water-based fluids in the sprayer if there is a chance it could freeze. Push the water out with mineral spirits. Frozen fluid in the sprayer prevents it from being started and may cause serious damage.

6. **Startup after storage.** Before using water-base paint, flush out the mineral spirits with soapy water and then clean water. When using oil-base paint, flush out the mineral spirits with the paint.

How to flush

1. Follow **Pressure Relief Procedure**. See page 2.
2. Remove the spray tip and clean it separately. Remove the filter screen and then reinstall the bowl, hand tight, without the screen. Clean the screen separately. See Fig 12.

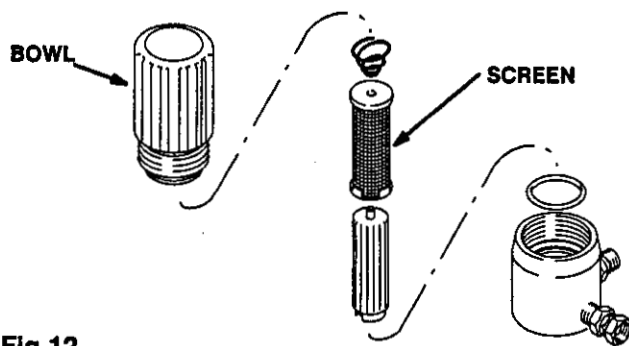

Fig 12

3. Pour one-half gallon (2 liters) of compatible solvent into a grounded metal flushing pail. Put the suction hose in the pail.
4. Open the pressure drain valve. See Fig 10.
5. **To save the paint still in the pump and hose,** follow Step 6, except put the drain hose in the paint pail. When solvent appears, close the drain valve. Put the drain hose in the flushing pail. Trigger the gun into the paint pail. When solvent appears, release the trigger. Continue with Step 6.

WARNING

To reduce static sparking and splashing, always remove the spray tip from the gun, and hold a metal part of the gun firmly to the side of a grounded metal pail when flushing. See Fig 13.

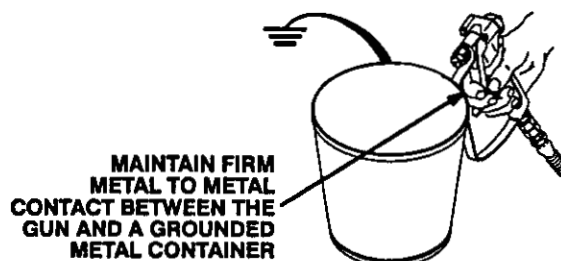

Fig 13

0483

6. Lower the pressure setting. Turn on the sprayer. Maintaining metal-to-metal contact, trigger the gun into the flushing pail. Slowly increase the sprayer pressure just until the pump starts. Keep the gun triggered until the solvent flows freely from the gun. Circulate the solvent to thoroughly clean the sprayer. Release the gun trigger. Engage the gun safety latch.
7. Open the drain valve and circulate the solvent through the drain hose to thoroughly clean it. Close the drain valve.
8. Remove the suction hose from the pail. Disengage the gun safety latch. Trigger the gun and run the pump a few seconds to push air into the hose. Do not run the pump dry for more than 30 seconds to avoid damaging the pump packings! Relieve pressure.
9. Reinstall the clean filter screen.
10. Remove and clean the inlet strainer. Wipe paint off the suction hose and drain hose.
11. Refer to **When To Flush**, Step 1 again. Relieve pressure.
12. Leave the drain valve open until you use the sprayer again.

TROUBLESHOOTING GUIDE

WARNING

Pressure Relief Procedure

To reduce the risk of serious bodily injury, including fluid injection, injury from splashing fluid or solvent in the eyes or on the skin, moving parts or electric shock, always follow this procedure whenever you shut off the sprayer, when checking or servicing any part of the spray system, when installing, cleaning or changing spray tips, and whenever you stop spraying.

1. Engage the gun safety latch.
2. Turn the ON/OFF switch to OFF.
3. Unplug the power supply cord.

4. Disengage the gun safety latch. Hold a metal part of the gun firmly to a grounded metal pail. Trigger the gun to relieve pressure.
5. Engage the gun safety latch.
6. Open the pressure drain valve, having a container ready to catch the drainage. Leave the pressure drain valve open until you are ready to spray again.

If you suspect that the spray tip or hose is completely clogged, or that pressure has not been fully relieved after following the steps above, VERY SLOWLY loosen the the tip guard retaining nut or hose coupling to relieve pressure gradually, then loosen completely.

Check everything in the guide before disassembling the sprayer.

BASIC PROBLEM SOLVING

| TYPE OF PROBLEM | WHAT TO CHECK <i>If check is OK, go to next check</i> | WHAT TO DO <i>When check is not OK, refer to this column</i> |
|-----------------|---|--|
| Fluid Pressure | 1. Check pressure control knob setting. The pump won't develop much pressure if it is at minimum setting (fully counterclockwise). | 1. Slowly increase pressure setting to see if motor starts. |
| | 2. Check for a clogged spray tip or fluid filter. See page 9. | 2. If tip is still clogged, relieve pressure; refer to separate gun or tip instruction manual for tip cleaning. Clean or replace filter element. See manual 308-249. |
| Mechanical | 1. Check for frozen or hardened paint in pump (20). Using a screwdriver, carefully try to rotate fan at back of motor by hand. See page 18. | 1. Thaw. Plug in sprayer and turn on. Slowly increase pressure setting to see if motor starts. If it doesn't, see NOTE 1, below. |
| | 2. Check pump connecting rod pin (17). It must be completely pushed into connecting rod (15), and retaining spring (18) must be firmly in connecting rod groove. See Fig 20, page 21. | 2. Push pin into place and secure with spring retainer. |
| | 3. Check for motor damage. Remove drive housing assembly (11). See page 26. Try to rotate motor fan by hand. | 3. Replace motor (4) if fan won't turn. See page 24. |
| Electrical | 1. Check electrical supply with volt meter. Meter should read 105-125 VAC. | 1. Reset building circuit breaker; replace building fuse. Try another outlet. |
| | 2. Check extension cord for visible damage. Use a volt meter or test lamp at extension cord outlet to check. | 2. Replace extension cord. |
| | 3. Check sprayer power supply cord (50) for visible damage such as broken insulation or wires. | 3. Replace power supply cord. See page 25. |
| | 4. Check motor brushes for the following: a. Loose terminal screws. b. Broken or misaligned brush springs. c. Brushes binding in holders. d. Broken leads. e. Worn brushes. NOTE: The brushes do not wear at same rate on both sides of motor. Check both brushes. | 4. Refer to page 20. a. Tighten. b. Replace broken spring and/or align spring with brush c. Clean brush holders. Remove carbon with small cleaning brush. Align brush leads with slot in brush holder to assure free vertical brush movement. d. Replace brushes e. Replace brushes if less than 1/2" long. |

NOTE 1: Thaw sprayer if water or water-based paint has frozen in it, due to exposure to low temperatures, by placing it in a warm area. Do not try to start sprayer until it has thawed completely or damage to motor and/or start board may occur. If paint hardened (dried) in sprayer, the pump packings and/or pressure transducer must be replaced. See page 21 (pump) or 27 (pressure transducer).

BASIC PROBLEM SOLVING

| TYPE OF PROBLEM | WHAT TO CHECK <i>If check is OK, go to next check</i> | WHAT TO DO <i>When check is not OK, refer to this column</i> |
|------------------------|--|--|
| Electrical (continued) | 5. Check motor armature commutator for burn spots, gouges and extreme roughness. Remove motor cover and brush inspection plates to check. See page 20. | 5. Remove motor and have motor shop resurface commutator if possible. See page 24. |
| | 6. Check motor armature for shorts using armature tester (growler) or perform motor test. See page 18. | 6. Replace motor. See page 24. |
| | 7. Check leads from pressure control and motor to motor start board (47) to be sure they are securely fastened and properly mated. | 7. Replace loose terminals; crimp to leads. Be sure male terminal blades are straight and firmly connected to mating part. |
| | 8. Check motor start board (47) by substituting with a good board. See page 25. CAUTION: Do not perform this check until motor armature is determined to be good. A bad motor armature can burn out a good board. | 8. Replace board. See page 25. |
| | 9. Check power supply cord (50). Disconnect black and white power cord terminals; connect volt meter to these leads. Plug in sprayer. Meter should read 105–125 VAC. Unplug sprayer. | 9. Replace power supply cord. See page 25. |
| | 10. Check ON/OFF switch (52). Disconnect the "L" wire between motor start board (47) and switch and connect volt meter between exposed terminal on switch and power cord's white wire. Plug in sprayer and turn ON. Meter should read 105–125 VAC. Turn off and unplug sprayer. | 10. Replace ON/OFF switch. See page 25. |
| | 11. Check motor thermal cutout switch. Connect ohmmeter between motor's red leads. Meter should read 1 ohm maximum. | 11. Allow motor to cool. Correct cause of overheating. If switch remains open after motor cools, replace motor. |
| | 12. Remove pressure control (64) and check micro-switch operation with ohmmeter: (1) With pressure knob at lowest setting and stem pushed into control, readings should be: white & black = 1 ohm max. white & red = open. (2) With pressure knob at highest setting, readings should be: white & black = open; white & red = 1 ohm max. | 12. Replace pressure control. See page 27. |
| | 13. Check pressure transducer (29) for hardened paint or damaged or worn components. See page 27. | 13. Replace transducer. See page 27. Thorough system flushing will help extend life of transducer. |

INTERMEDIATE PROBLEM SOLVING

| TYPE OF PROBLEM | WHAT TO CHECK <i>If check is OK, go to next check</i> | WHAT TO DO <i>When check is not OK refer to this column</i> |
|-----------------|--|---|
| Low Output | 1. Check for worn spray tip. | 1. Follow Pressure Relief Procedure Warning then replace tip. See your separate gun or tip manual. |
| | 2. Be sure pump does not continue to stroke when gun trigger is released. Plug in and turn on sprayer. Prime with paint. Trigger gun momentarily, then release and engage safety latch. Relieve pressure, turn off and unplug sprayer. | 2. Service pump. See pages 21. |

INTERMEDIATE PROBLEM SOLVING

| TYPE OF PROBLEM | WHAT TO CHECK <i>If check is OK, go to next check</i> | WHAT TO DO <i>When check is not OK, refer to this column</i> |
|--|--|--|
| Low Output <i>(continued)</i> | 3. Release gun trigger. Observe resting position of pump rod (107). | 3. If pump consistently comes to rest with rod (107) fully extended, the piston packings and/or piston valve may be worn. Service the pump. See page 21. |
| | 4. Check electrical supply with volt meter. Meter should read 105–125 VAC. | 4. Reset building circuit breaker; replace building fuse. Repair electrical outlet or try another outlet. |
| | 5. Check extension cord size and length; must be at least 12 gauge wire and less than 150 ft. | 5. Replace with a correct, grounded extension cord. |
| | 6. Check motor brushes. See Electrical – What To Check, item 4, on page 14. | 6. See page 20. |
| | 7. Check motor start board (47) by substituting with a good board. CAUTION: Do not perform this check until motor armature is determined to be good. A bad motor armature can burn out a good board. | 7. Replace board. See page 25. |
| 8. Check motor armature for shorts by using an armature tester (growler) or perform motor test. See page 18. | 8. Replace motor. See page 24. | |
| Drain Valve Leaks | 1. Check drain valve for correct torque and/or worn parts. Check for debris trapped on seat. | 9. Tighten to 185 in-lb (21 N.m). Clean valve and replace with new gasket (42a) and sealant (42d). See page 28. |
| Transducer Leaks | 1. Slight leakage from transducer is normal. | 1. Periodically remove residue from its cylinder port. See page 27. |
| No Output: Motor Runs And Pump Strokes | 1. Check paint supply. | 1. Refill and reprime pump. |
| | 2. Check for clogged intake strainer. | 2. Remove and clean, then reinstall. |
| | 3. Check for loose suction tube or fittings. See page 28. | 3. Tighten; use thread sealant on npt threads of inlet tube (38). Check for damaged o-ring (27). |
| | 4. Check to see if intake valve ball and piston ball are seating properly. See page 21. | 4. Remove intake valve and clean. Check ball and seat for nicks; replace as needed. See page 21. Strain paint before using to remove particles that could clog pump. |
| | 5. Check for leaking around throat packing nut which may indicate worn or damaged packings. See page 21. | 5. Replace packings. See page 21. Also check piston valve seat for hardened paint or nicks and replace if necessary. Tighten packing nut/wet-cup. |
| | 6. Release gun trigger. Observe resting position of pump rod (107). | 6. If pump consistently comes to rest with rod (107) fully extended, the piston packings and/or piston valve may be worn. Service the pump. See page 21. |
| No Output: Motor Runs But Pump Does Not Stroke | 1. Check displacement pump connecting rod pin (17). See Fig 20, page 21. | 1. Replace pin if missing. Be sure retainer spring (18) is fully in groove all around connecting rod. |
| | 7. Check connecting rod assembly (15) for damage. See page 26. | 7. Replace connecting rod assembly. See page 26. |
| | 8. Be sure crank in drive housing rotates; plug in sprayer and turn on briefly to check. Turn off and unplug sprayer. See page 26. | 8. Check drive housing assembly for damage and replace if necessary. See page 26. |

INTERMEDIATE PROBLEM SOLVING

| TYPE OF PROBLEM | WHAT TO CHECK <i>If check is OK, go to next check</i> | WHAT TO DO <i>When check is not OK, refer to this column</i> |
|--|--|---|
| Spray Pattern Variations | 1. Spray tip worn beyond sprayer pressure capability. | 1. Replace spray tip. NOTE: A smaller size tip will provide longer life. |
| | 2. Check transducer (29) for wear or damage. | 2. Replace transducer. See page 27. |
| | 3. Check pressure control (64) for smooth operation. | 3. Replace pressure control. See page 27. |
| | 4. Check Low Output section, page 16. | |
| Motor Is Hot and Runs Intermittently | 1. Determine if sprayer was operated at high pressure with small tips, which causes excessive heat build up. | 1. Decrease pressure setting or increase tip size. |
| | 2. Be sure ambient temperature where sprayer is located is no more than 90°F and sprayer is not located in direct sun. | 2. Move sprayer to shaded, cooler area if possible. |
| | 3. Check motor. | 3. Replace motor. See page 24. |
| Building Circuit Breaker Opens As Soon As Sprayer Switch Is Turned On. | 1. Check all electrical wiring for damaged insulation, and all terminals for loose fit or damage. Also check wires between pressure control and motor. See page 24. | 1. Repair or replace any damaged wiring or terminals. Securely reconnect all wires. |
| | 2. Check for missing motor brush inspection plate gasket (see page 20), bent terminal forks or other metal to metal contact points which could cause a short. | 2. Correct faulty conditions. |
| | 3. Check motor armature for shorts. Use an armature tester (growler) or perform motor test. See page 18. Inspect windings for burns. | 3. Replace motor. See page 24. |
| | 4. Check motor start board (47) by substituting with a good board. CAUTION: Do not perform this check until motor armature is determined to be good. A bad motor armature can burn out a good board. | 4. Replace board. See page 25. |
| Circuit breaker opens after sprayer operates for 5 to 10 minutes. | 1. Check 'Basic Problems – Electrical' on page 14. | |
| Building circuit breaker opens as soon as sprayer is plugged into outlet and sprayer is NOT turned on. | 1. Check electrical supply with volt meter. Meter should read 105–125 VAC. | 1. If voltage is too high, do not operate sprayer until corrected. |
| | 2. Check tightness of pump packing nut. Overtightening tightens packings on rod, restricts pump action, damages packings. | 2. Loosen packing nut. Check for leaking around throat. Replace pump packings, if necessary. See page 21. |
| | 3. Check for damaged motor. | 3. Replace motor. See page 24. |
| | 4. Check ON/OFF switch (52). <i>Be sure sprayer is unplugged!</i> Disconnect wires from switch. Check switch with ohmmeter. The reading should be infinity with ON/OFF switch OFF, and zero with switch ON. CAUTION: A short in motor circuit can damage switch and or motor start board (47). | 4. Replace ON/OFF switch. See page 25. |

WARNING

To reduce the risk of serious injury, follow the **Pressure Relief Procedure Warning** on page 14 before doing this procedure. Unplug the sprayer!

For checking armature, motor winding and brush electrical continuity.

Setup

Remove the drive housing. See page 26. This is to ensure that any resistance you notice in the armature test is due to the motor and not to worn gears in the drive housing.

Remove the motor brush inspection covers (A). See 14.

Remove the junction box screws (56). Lower the junction box. Disconnect the two leads (C) from the motor to the board (47). See Fig 15.

Armature Short Circuit Test

Remove the handle (24) and the fan cover (B). See Fig 14.

Spin the motor fan by hand. If there are no shorts, the motor will coast two or three revolutions before coming to a complete stop. If the motor does not spin freely, the armature is shorted and the motor must be replaced. See page 24.

Armature, Brushes, and Motor Wiring Open Circuit Test (Continuity)

Connect the two black motor leads together with a test lead. Turn the motor fan by hand at about two revolutions per second.

When turning the fan on a DC motor, normally you sense an even, pulsing resistance. If there is irregular turning resistance, or no turning resistance, check and repair the following as needed: broken brush springs, brush leads, motor leads; loose brush terminal screws, motor lead terminals; worn brushes. See page 20.

If there is still uneven or no turning resistance, replace the motor. See page 24.

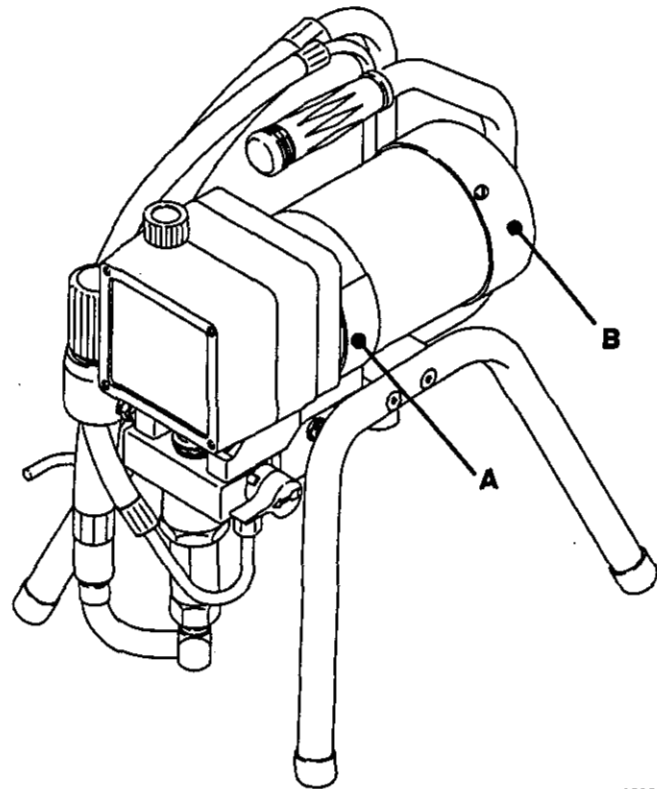

Fig 14

1022

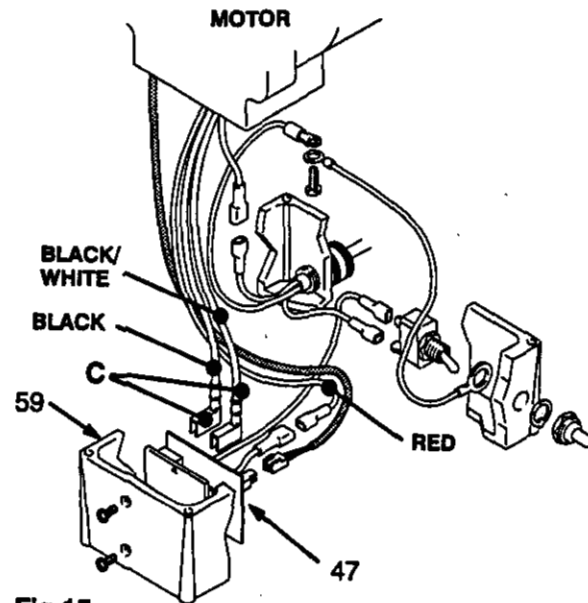

Fig 15

GENERAL REPAIR INFORMATION

WARNING

Pressure Relief Procedure

To reduce the risk of serious bodily injury, including fluid injection, splashing fluid or solvent in the eyes or on the skin, or injury from moving parts or electric shock, always follow this procedure whenever you shut off the sprayer, check or service any part of the spray system, install, clean or change spray tips, and whenever you stop spraying.

1. Engage the gun safety latch.
2. Turn the ON/OFF switch to OFF.
3. Unplug the power supply cord.

4. Disengage the gun safety latch. Hold a metal part of the gun firmly to the side of a grounded metal pail, and trigger the gun to relieve pressure.
5. Engage the gun safety latch.
6. Open the pressure drain valve, having a container ready to catch the drainage. Leave the valve open until you are ready to spray again.

If you suspect that the spray tip or hose is completely clogged, or that pressure has not been fully relieved after following the steps above, VERY SLOWLY loosen the tip guard retaining nut or hose coupling to relieve pressure gradually, then loosen completely. Now clear the tip or hose.

Tool List

These are the tools required to service all parts of the sprayer.

3/16" Allen® wrench: *gear housing, legs, handle*

3/8" Allen® wrench: *pump manifold*

#1 Phillips® screwdriver: *junction box, pressure control, front cover*

3/8" socket wrench: *motor mount*

5/8" socket wrench: *drain valve, outlet fittings, on/off switch boot, piston*

13/16" socket wrench: *drain valve*

1-1/4" socket wrench: *pump inlet valve*

1/2" open end wrench: *pump rod*

11/16" open end wrench: *piston jam nut*

15/16" open end wrench: *flats of inlet tube*

1-3/4" open end wrench: *pump jam nut*

5/64" drive pin: *drain valve pin*

3" needle nose pliers: *wiring, on/off switch*

Hammer & punch: *packing nut*

Torque wrenches: *various fasteners*

1. **When disconnecting wires** in the junction box assembly, use needle nose pliers to separate mating connectors.
2. **When reconnecting the wires**, be sure the flat blade of the insulated male connector is centered in the wrap-around blade of the female connector.

CAUTION

To reduce the risk of a pressure control malfunction, be sure to properly mate connectors, and never pull on a wire to disconnect it. Pulling on a wire could loosen the connector from the wire.

3. **Route wires carefully** through the drive housing and motor. Avoid pinching the wires between the junction box and the motor.

CAUTION

Improper wire routing can result in poor sprayer performance or damage to the pressure control.

4. **Keep all screws, nuts, washers, gaskets, and electrical fittings** removed during repair procedures. These parts are not normally provided with replacement assemblies.
5. **Test your repair before regular operation** to be sure the problem is corrected.
6. **If the sprayer does not operate properly**, verify that everything was done correctly. Also refer to the Troubleshooting Guide, pages 14–17, to help identify other possible problems and solutions.

WARNING

To reduce the risk of serious bodily injury, including electric shock, **DO NOT** touch any moving parts or electrical parts with your fingers or a tool while inspecting the repair.

Shut off the sprayer and unplug it as soon as you complete the inspection.

Reinstall all covers, gaskets, screws and washers before operating the sprayer.

WARNING

During operation, the motor and drive housing become very hot and could burn your skin if touched. Flammable materials spilled on the hot, bare motor could cause a fire or explosion.

MOTOR BRUSH REPLACEMENT

NOTE 1: Replace the brushes when they have worn to less than 1/2 in (13 mm). Refer to Fig 17. Note that the brushes wear differently on each side of the motor, so check them both. Brush Repair Kit 235-727 is available.

WARNING

To reduce the risk of serious injury, follow the **Pressure Relief Procedure Warning** on page 19 before doing this procedure. Unplug the sprayer!

1. Remove both inspection covers (A) and their gaskets. See Fig 16.

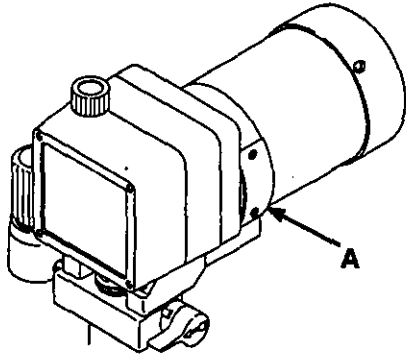

Fig 16

2. Push in the spring clip and release its hooks from the brush holder. Pull out the spring clip. See Fig 17.
3. Loosen the brush lead terminal screw. Pull the brush lead away, but leave the motor lead terminal in place. Remove and discard the brush. See Fig 17.
4. Inspect the commutator for excessive pitting, burning or gouging. A black color on the commutator is normal. Have the commutator resurfaced by a qualified motor repair shop if the brushes seem to wear too fast or arc excessively.

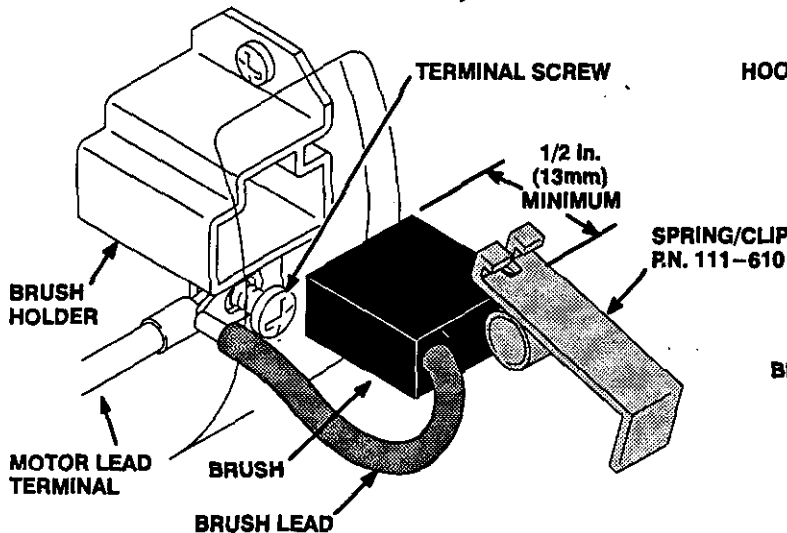

Fig 17

5. Repeat for the other side.

CAUTION

When installing the brushes, follow all steps carefully. Improper installation damages parts beyond use.

6. Place a new brush in the holder so the lead is closer to the fan-end of the motor. Slide the terminal under the terminal screw washer. Ensure the motor lead is still connected at the screw. See Fig 17.
7. Holding the spring/clip at a slight angle, slide the spring/clip into the brush holder and hook it over the end of the holder. See Fig 18. Pull on the spring/clip to be sure it stays in place. Be sure the brush lead is tucked under the spring/clip tab.
8. Repeat for the other side.
9. Test the brushes.
 - a. With the sprayer OFF, turn the pressure control knob fully counterclockwise to minimum pressure. Plug in the sprayer.
 - b. Turn the sprayer ON. Slowly increase the pressure until the motor is at full speed.
 - c. Inspect the brush and commutator contact area for excessive arcing. Arcs should not "trail" or circle around the commutator surface.

WARNING

Do not touch the brushes, leads, springs or brush holders while the sprayer is plugged in to reduce the risk of electric shock and serious bodily injury.

CAUTION

Do not run the sprayer dry for more than 30 seconds while checking the brushes to avoid damaging the displacement pump packings.

10. Install the brush inspection covers and gaskets.

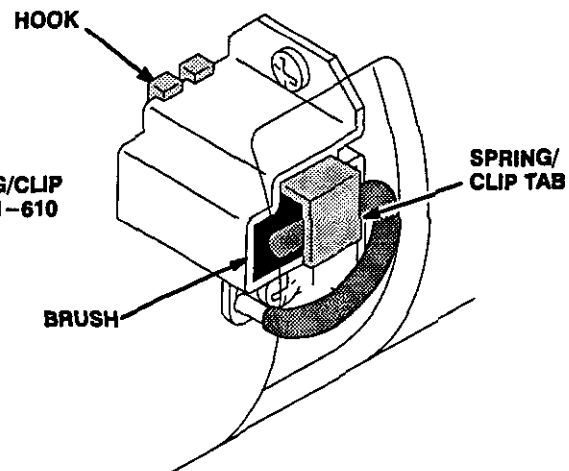

Fig 18

DISPLACEMENT PUMP

WARNING

To reduce the risk of serious injury, follow the **Pressure Relief Procedure Warning** on page 19 before doing this procedure. Unplug the sprayer!

NOTE 1: Packing Repair Kit 235-703 is available. Reference numbers of parts included in the kit are marked with an asterisk, i.e., (121*). For the best results, use all the new parts in the kit, even if the old ones still look good.

NOTE 2: To minimize down time, and for the best sprayer performance, check the motor brushes (see page 20) and clean the transducer (see page 27) whenever you repack the pump. Replace these parts as needed.

Intake valve repair (See Fig 19)

1. Unscrew the intake valve (118). Remove the o-ring (119*), ball guide (120), stop pin (122*) and ball (121*) from the valve.
2. Clean and inspect the parts for wear or damage. Replace parts as needed. Use a new o-ring (119*). If no further service is needed, reassemble the pump.

NOTE 3: For additional pump repair, go to page 22.

Removing the pump (See Fig 19)

1. Flush the pump, if possible. Relieve pressure. Stop the pump with the piston rod (107) in its lowest position, if possible. To lower the piston rod manually, rotate the motor fan blades.
2. Remove the filter (85).
3. While pulling upward on the suction hose (32), unscrew the hose from the inlet tube (38). Unscrew the drain hose (33) from the displacement pump nipple (36).

NOTE 4: If repairing only the intake valve assembly, go to **Intake valve repair**, below.

4. Use a screwdriver to push the retaining spring (18) up and push out the pin (17).
5. Loosen the screws (21). Remove the pump (20).

Installing the pump (See Fig 19 and 20)

1. Mount the pump on the drive housing. Tap it into the alignment pins with a soft hammer. Tighten the screws (21) to 50 ft-lb (68 N.m).
2. Align the hole in the rod (107) with the connecting rod assembly (15). Use a screwdriver to push the retaining spring (18) up and push in the pin (17). Push the retaining spring (18) into place around the connecting rod.

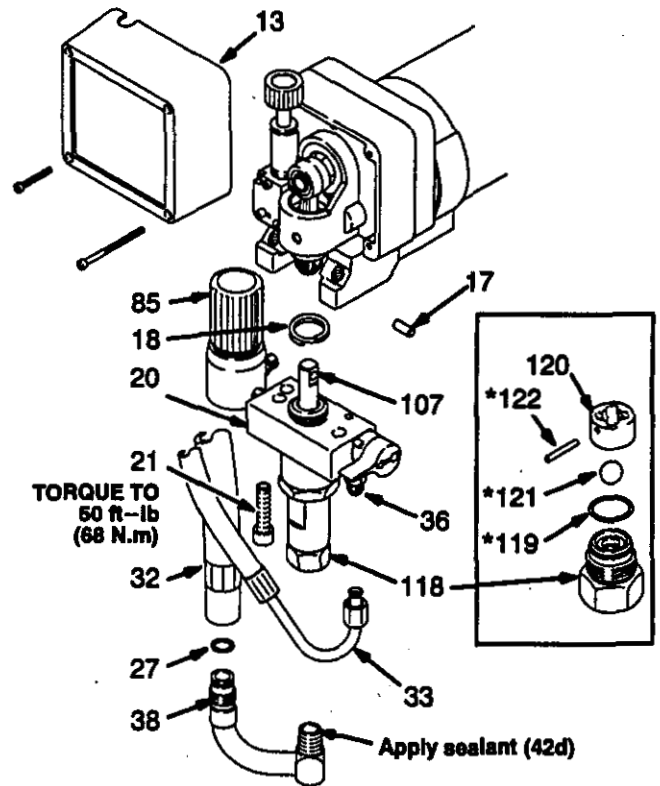

Fig 19

1073

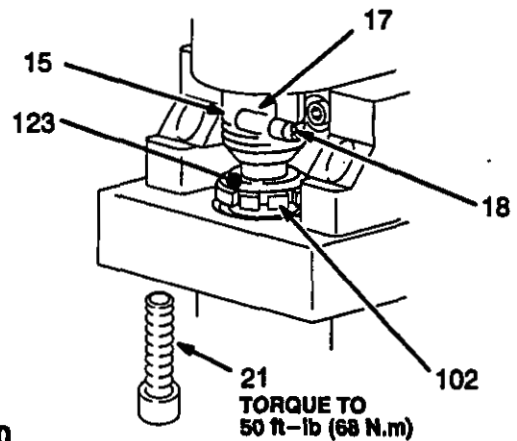

Fig 20

WARNING

Be sure the retaining spring (18) is firmly in the groove all the way around, to prevent the pin (17) from working loose due to vibration. See Fig 20.

If the pin works loose, it or other parts could break off due to the force of the pump action. These parts could be projected into the air and result in serious injury or property damage, including the pump connecting rod or bearing housing.

3. Replace the o-ring (27) if it is worn or damaged. Reconnect the suction and drain hoses (32,33). Install the front cover (13).
4. Tighten the packing nut (102) just enough to stop leakage, but no tighter. Fill the packing nut/wet-cup 1/3 full with Graco TSL. Push the plug (123) into the wet-cup.

DISPLACEMENT PUMP

Disassembling the pump (See Fig 21)

1. Remove the intake valve (118). See page 21.
2. Unscrew the packing nut (102) and plug (123).
3. Use a plastic mallet to tap the piston rod (107) down, and then pull the rod out through the bottom of the cylinder.
4. Remove the throat packings.
5. Loosen the jam nut (117). Remove the cylinder (115) and the o-ring (116*).
6. Clamp the flats of the piston rod in a vise. Use an open-end wrench to loosen the nut (110) and then unscrew the piston valve (108).
7. Remove all parts from the piston valve (108).

Reassembling the pump

NOTE 1: Alternate plastic and leather packings. See Fig 21. The lips of the throat V-packings face down. The lips of the piston V-packings face up. Incorrect installation damages the packings and causes pump leaking.

NOTE 2: Soak the leather packings in oil before reassembling the pump.

1. Check the outside of the piston rod (107) and the inside of the cylinder (115) for wear. Replace worn parts to ensure a good seal with the new packings.
2. Stack these parts onto the piston valve (108) one at a time: the backup washer (126*) and u-cup (125*), the female gland (114*), alternately three plastic (112*) with two leather packings (113*), and the male gland (111*). See Fig 22.
3. Tighten the nut (110) onto the piston valve (108) to 2 in-lb (0.23 N.m). See Fig 22.

NOTE 3: Note the alignment of the piston (108) to the nut (110). Maintain this alignment through Step 8.

4. Clean all residue from the piston valve threads. Apply one drop of adhesive, supplied, to the threads.
5. Place the ball (109*) on the piston valve (108). See Fig 22.

CAUTION

Step 6, tightening the piston valve into the rod, is critical. Follow the procedure carefully to avoid damaging the packings by overtightening.

6. Hand tighten the valve into the piston rod just until the nut (110) contacts the rod. See Fig 23.

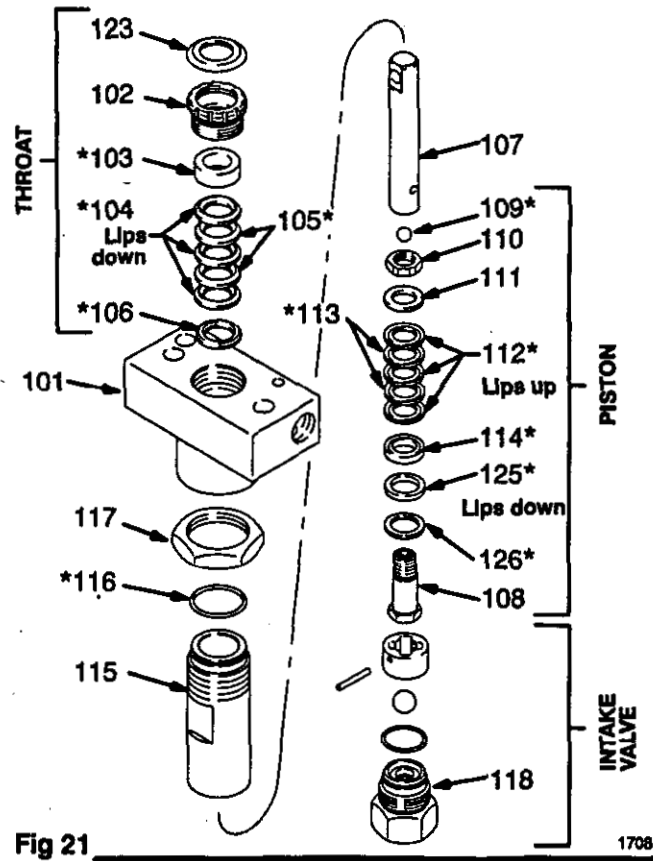

Fig 21

1708

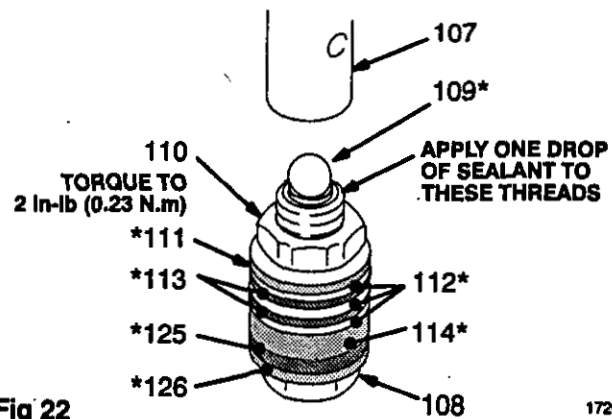

Fig 22

1720

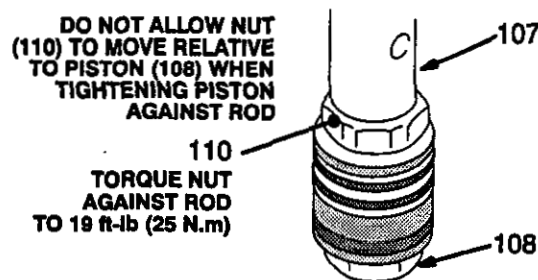

Fig 23

1721

7. Place the flats of the rod (107) in a vise.
8. **CAREFULLY** tighten the nut (110) against the piston rod to 19 ft-lb (25 N.m). See Fig 23.

Use two wrenches to maintain the alignment mentioned in NOTE 3, to the left.

DISPLACEMENT PUMP

9. Stack these parts one at a time into the top of the manifold (101): the male gland (106*), alternately three plastic packings (104*) with two leather packings (105*), and then the female gland (103*). See Fig 25.
10. Install the packing nut (102) and plug (124), but leave loose for now. See Fig 24.
11. Place a new o-ring (116*) firmly in the cylinder groove. See Fig 24.
12. Coat the piston rod and packings with oil. Carefully slide the assembly INTO THE TOP OF THE CYLINDER (115). See Fig 24.
13. Place the intake valve (118) in a vise and assemble its parts. See page 21. Screw the cylinder (115) onto the valve (118). Turn the jam nut (117) all the way down. See Fig 24.
14. Put the manifold in a vise. Guide the rod/cylinder assembly up through the manifold (101). Screw the cylinder (115) into the manifold and tighten to 53 ft-lb (71 N.m). See Fig 24.
15. Tighten intake valve (118) to 53 ft-lb (71 N.m). See Fig 24.
16. Tighten the cylinder jam nut (117) to 73 ft-lb (98 N.m). See Fig 24.
17. Install the pump. See page 21.

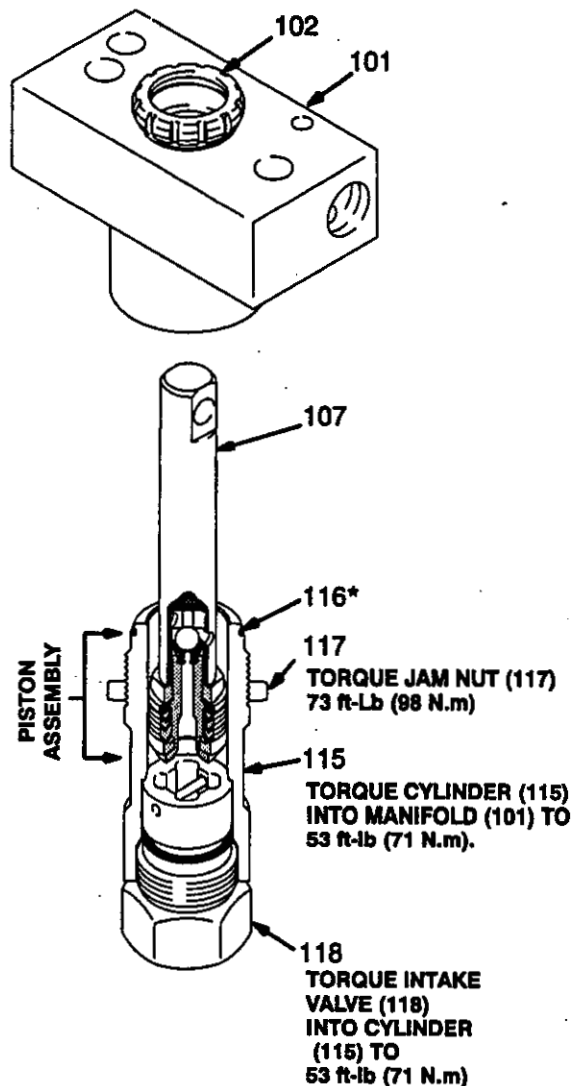

Fig 24

1717

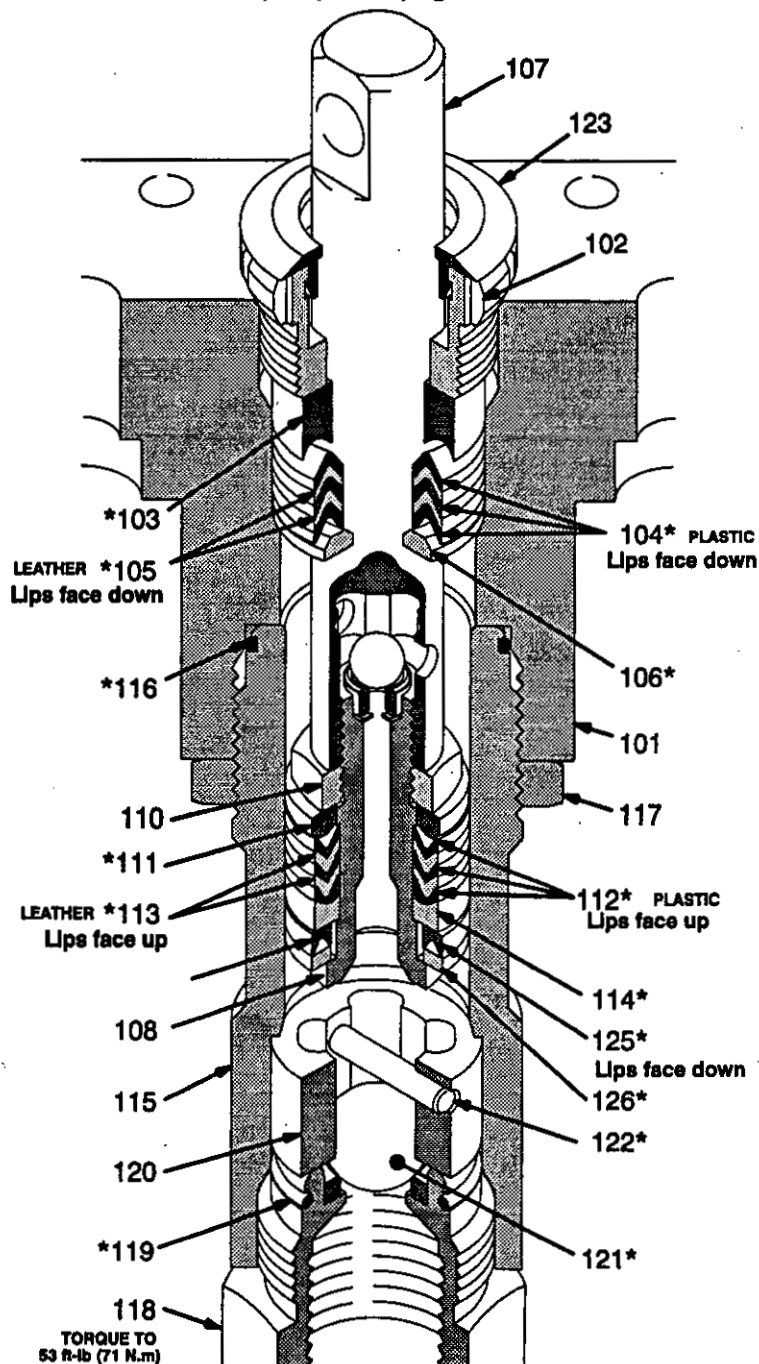

Fig 25

1709

MOTOR

WARNING

To reduce the risk of serious injury, follow the **Pressure Relief Procedure Warning** on page 19 before doing this procedure. Unplug the sprayer!

NOTE 1: See Fig 27 except where noted.

NOTE 2: Stop the sprayer at the bottom of its stroke to get the crank (12) in the lowest position. To manually lower the crank, rotate the blades of the motor fan with a screwdriver.

1. Remove the drive housing (11). See Steps 1 to 5, page 26.
2. Rotate the blades of the motor fan to raise the crank (12). Turn the displacement pump rod (107) so the pin hole aligns with the bottom screw (19), which gives access to that screw. See Fig 26.
3. Remove the three drive housing screws (19) and two motor screws (5) and their lockwashers (6).
4. Tap the lower rear of the drive housing (11) with a plastic mallet to loosen the motor. Pull the drive housing straight off the motor while guiding the harness (A) from the motor.

CAUTION

Do not allow the gear (16) to fall; it may stay attached to the drive housing or to the motor.

Do not lose the thrust balls (11a or 4a) or allow them to fall between the gears, which will seriously damage the drive housing if not removed. The balls, which are heavily covered with grease, usually stay in the gear recesses, but could be dislodged. If the balls are not in place, the bearings will wear prematurely.

5. Remove the two screws (46) and lift the motor off the base (66). Align the new motor with the base and reinstall the screws.

NOTE 3: The gears and bearings between the drive housing (11) and motor front end bell (C) should contain a total of 3 fl. oz. of grease.

6. Grease the gear cluster (16) and pinion gear (B) and pack all bearings. Be sure the thrust balls (11a, 4a) are in place.
7. Place the large washer (12a) and then the small washer (12b) on the crankshaft (12).
8. Lift the crank to the top of the stroke and insert crankshaft (12). Align the gears and push the drive housing (11) straight onto the motor and the locating pins. Install the screws (19, 5) and their lockwashers (6). Torque to 80 in-lb (9 N.m).
9. See page 27, Steps 5–9, to install the pressure control (64) and junction box (59).
10. Reconnect the piston rod (107) to the drive housing; see page 21, **Installing the Pump**, Step 2 and the Warning following it.

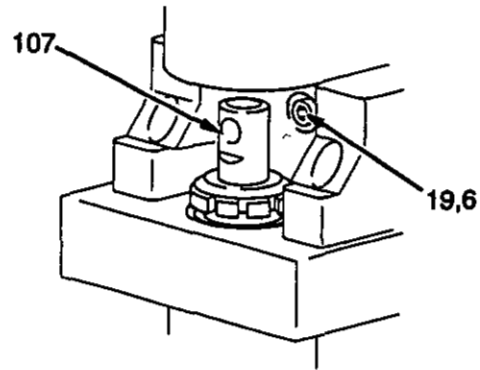

Fig 26

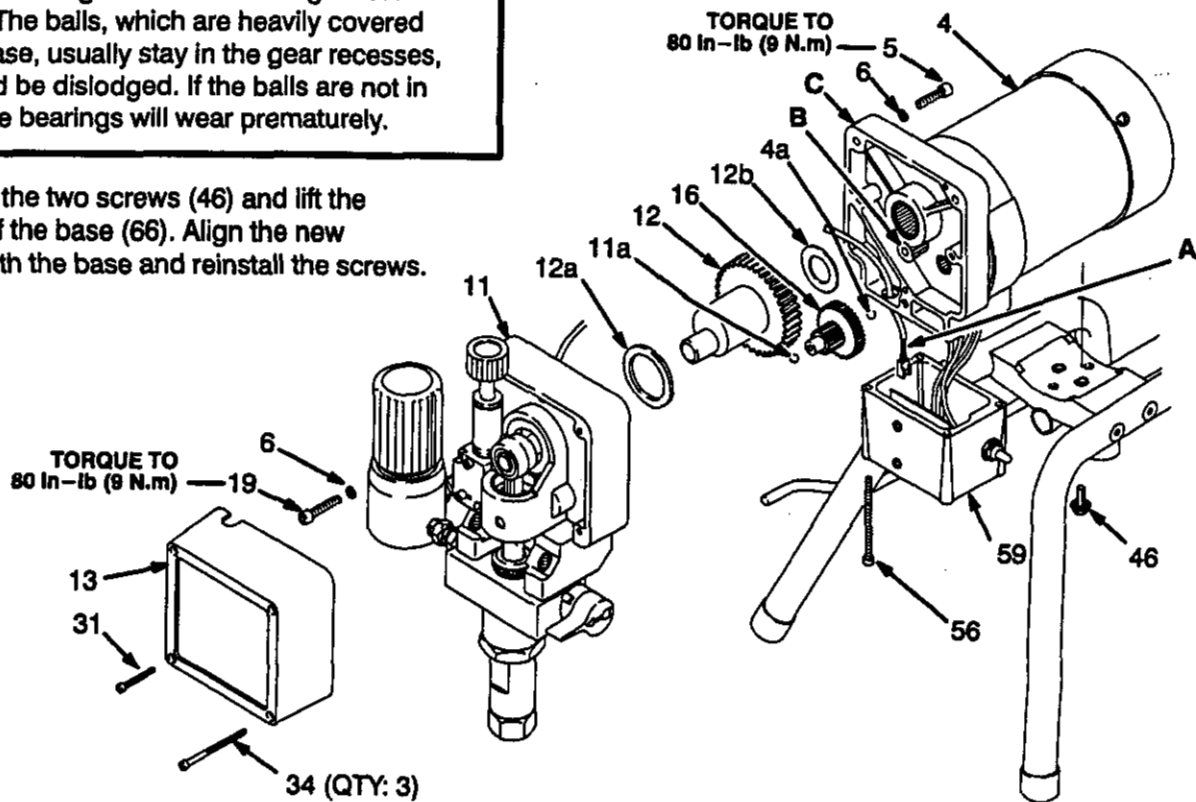

Fig 27

1080

MOTOR START BOARD

WARNING

To reduce the risk of serious injury, follow the **Pressure Relief Procedure Warning** on page 19 before doing this procedure. Unplug the sprayer!

1. Remove the junction box screws (56) and lower the junction box (59). See Fig 28.
2. Disconnect the motor wires (4b) and the 3-wire connector (A) from the motor start board (47). Observe where connections are made. See Fig 28.
3. Remove the screws (58) and motor start board (47). Transfer the white thermal paste from the old board to the new board. See Fig 28.
4. Install the new motor start board. Reconnect all wires. Mount the junction box.

CAUTION

Be sure the flat blade of the insulated male connector is centered in the wrap-around blade of the female connector when the connections are made.

Route all wires carefully to avoid interference with the motor start board or junction box.

These precautions are essential to reduce the risk of a malfunction.

POWER SUPPLY CORD

WARNING

To reduce the risk of serious injury, follow the **Pressure Relief Procedure Warning** on page 19 before doing this procedure. Unplug the sprayer!

1. Remove the junction box screws (56) and lower the junction box (59). See Fig 28.
2. Disconnect the power supply cord leads, including the green wire to the grounding screw (49). See Fig 28.
3. Loosen the strain relief bushing (51). Remove the power supply cord (50).
4. Install the new cord (50) in the reverse order of disassembly.
5. Install the junction box. Be sure no leads are pinched against the motor or by the motor start board.

ON/OFF SWITCH

WARNING

To reduce the risk of serious injury, follow the **Pressure Relief Procedure Warning** on page 19 before doing this procedure. Unplug the sprayer!

1. Remove the junction box screws (56) and lower the junction box (59). See Fig 28.
2. Remove the nut and rubber boot (55).
3. Disconnect the black wires from the ON/OFF switch (52) and remove the switch. See Fig 28.
4. Place the ring terminal of the ground wire (53) over the barrel of the new switch. Install the switch so the internal tab of the anti-rotation ring (54) engages with the vertical groove in the threads of the switch, and the external tab engages with the blind hole (C) of the junction box.
5. Powder the inside of the rubber boot (55) with talcum, then shake the excess out of the boot. Install the nut and rubber boot and tighten.
6. Reconnect the ON/OFF switch black wires.
7. Install the junction box. Be sure no leads are pinched against the motor or by the motor start board.

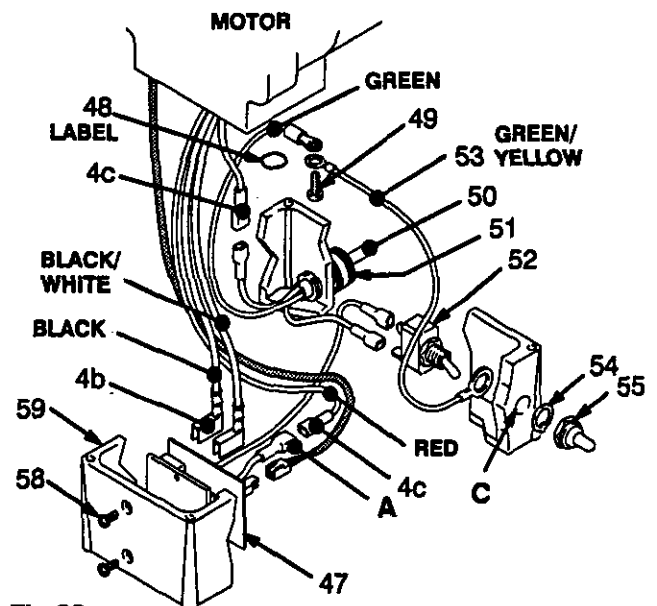

Fig 28

DRIVE HOUSING, CONNECTING ROD & CRANKSHAFT

WARNING

To reduce the risk of serious injury, follow the **Pressure Relief Procedure Warning** on page 19 before doing this procedure. Unplug the sprayer!

NOTE 4: Inspect parts as they are removed. Replace parts that are worn or damaged.

1. Rotate the blades of the motor fan with a screwdriver to get the crank in its lowest position.
2. Remove the displacement pump. See page 21.
3. Remove the pressure control (64). See page 27.

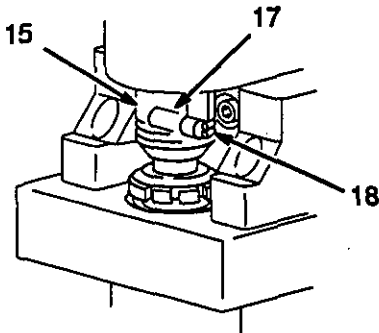

Fig 29

4. Remove the three screws (19) and the two motor screws (5) and their lockwashers (6).
5. Tap the lower rear of the drive housing (11) with a plastic mallet to loosen the motor. Pull the drive housing straight off the motor while guiding the harness (A) from the motor.

CAUTION

Do not allow the gear (16) to fall; it may stay attached to the drive housing or to the motor.

Do not lose the thrust balls (11a or 4a) or allow them to fall between the gears, which will seriously damage the drive housing if not removed. The balls, which are heavily covered with grease, usually stay in the gear recesses, but could be dislodged. If the balls are not in place, the bearings will wear prematurely.

Note: Filter not shown

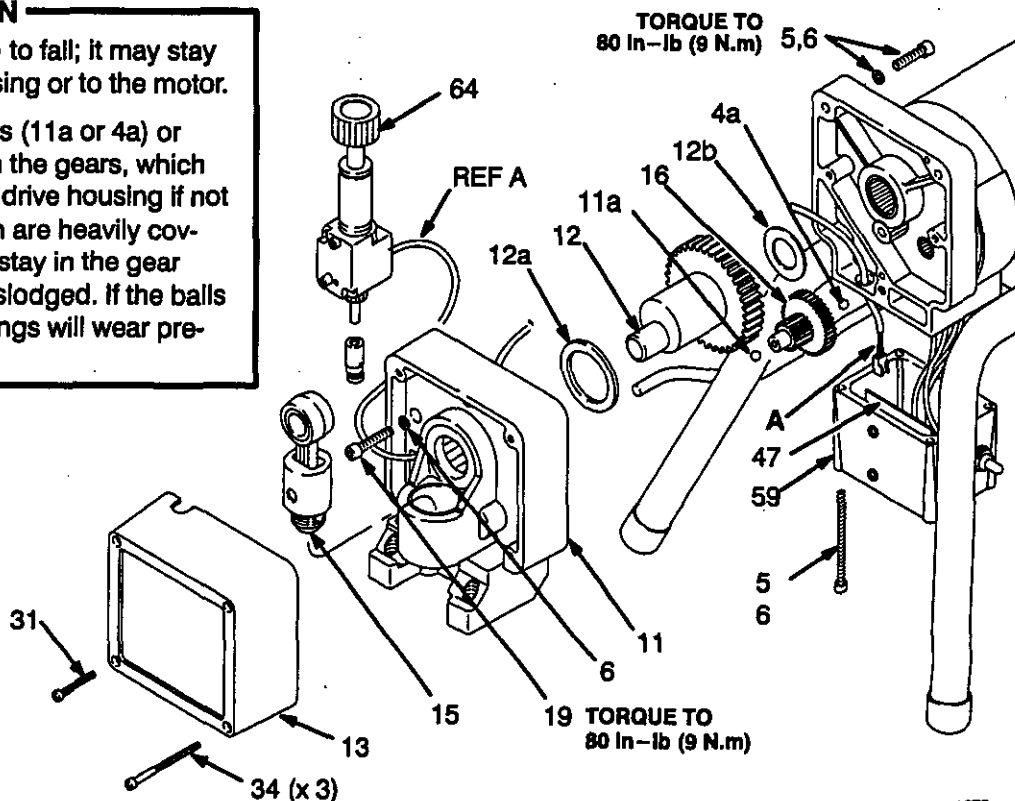

Fig 30

6. Remove and inspect the crankshaft (12) and the connecting rod (15).
7. Install the connecting rod.
8. Lubricate the inside of the drive housing bearing with SAE non-detergent oil. Pack the roller bearing and gears with the grease supplied.

NOTE 5: The gears and bearings between the drive housing (11) and motor front end bell (C) should contain a total of 3 fl. oz. of grease.

9. Route the wire harness (A) through the motor passages to the junction box (59).
10. Place the large washer (12a) and then the small washer (12b) on the crankshaft (12).
11. Lift the crank to the top of the stroke and insert crankshaft (12). Align the gears and push the drive housing (11) straight onto the motor and the locating pins. Install the screws (19, 5) and their lockwashers (6). Torque to 80 in-lb (9 N.m).
12. Install the displacement pump. See page 21.
13. Install the front cover (13) and the pressure control (64). See page 27.

PRESSURE CONTROL

WARNING

To reduce the risk of serious injury, follow the **Pressure Relief Procedure Warning** on page 19 before doing this procedure. Unplug the sprayer!

NOTE 1: See Fig 31 for this procedure.

NOTE 2: The pressure control (64) cannot be repaired or adjusted. If it has malfunctioned, replace it.

1. Remove the front cover (13). Remove the screws (56). Lower the junction box (59).
2. Disconnect the harness connector (A) from the motor start board (47).
3. Remove the screws (63). Pull forward on the pressure adjusting knob and tip the pressure control (64) forward and up to detach it from the drive housing (11).
4. Guide the harness (A) through the motor and drive housing and remove the pressure control.
5. Guide the harness of the new pressure control through the drive housing and motor passages.
6. Install the new pressure control. Tip the pressure control down and back into the drive housing (11). Do not pinch or damage the harness (A).
7. Loosely install the screws (63) and then torque them to 21 in-lb (2.4 N.m).

8. Install the front cover (13). Connect the harness (A) to the motor start board (47).
9. Install the junction box. Be sure no leads are pinched against the motor or by the motor start board.

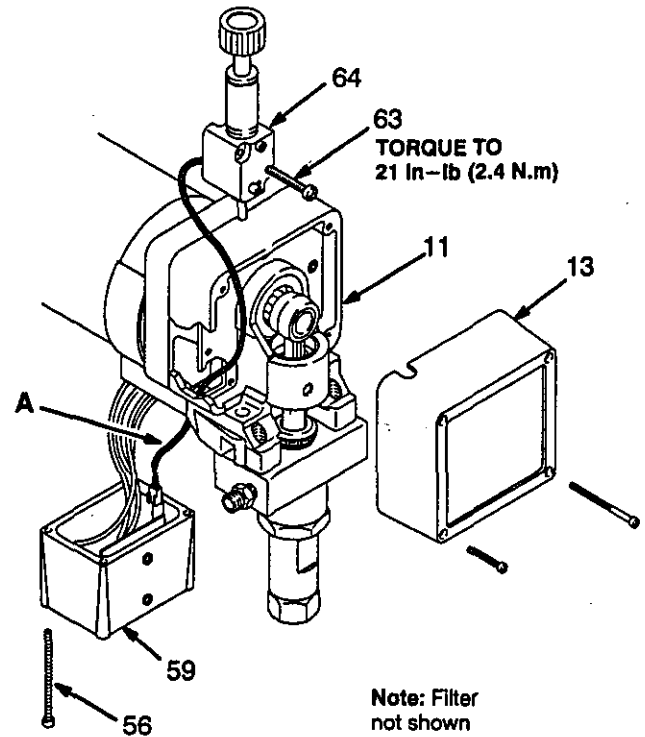

Fig 31

1080

PRESSURE TRANSDUCER

WARNING

To reduce the risk of serious injury, follow the **Pressure Relief Procedure Warning** on page 19 before doing this procedure. Unplug the sprayer!

NOTE 1: See Fig 32 for this procedure.

1. Remove the displacement pump. See page 21.
2. Use a pull-twist motion to remove the transducer (29) from the pump manifold (101).
3. Clean paint residue from the hole in the manifold; do not scratch the surface of the hole.
4. Lightly apply oil to the o-ring of the new transducer.
5. Install the transducer in the pump manifold, while guiding the o-ring and backup ring into place.
6. Align the holes in the transducer as shown by the arrows in Fig 32.
7. Install the displacement pump. See page 21.

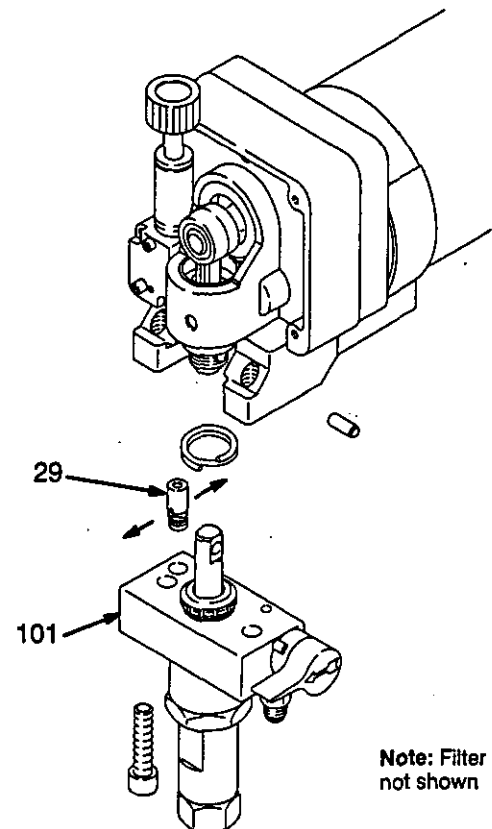

Fig 32

Note: Filter not shown

SUCTION HOSE

WARNING

To reduce the risk of serious injury, follow the **Pressure Relief Procedure Warning** on page 19 before doing this procedure. Unplug the sprayer!

1. Remove the drain hose (33) from the clip. Remove the front cover (13).
2. Pull upward on the hose (32) while unscrewing it from the inlet tube (38). The hose coupling (A) threads will engage and the hose will separate from the tube.
3. Replace the o-ring (27) if it is worn or damaged.
4. Lubricate the o-ring (27) and the inlet tube (38) threads with light grease.
5. Align the suction hose coupling with the threads of the inlet tube (38). Tighten the hose onto the tube at least 4 turns to ensure that the threads have disengaged and can function as a swivel joint.

CAUTION

Misalignment or cross-threading will damage the parts and/or create shavings which can cause the o-ring (27) to leak.

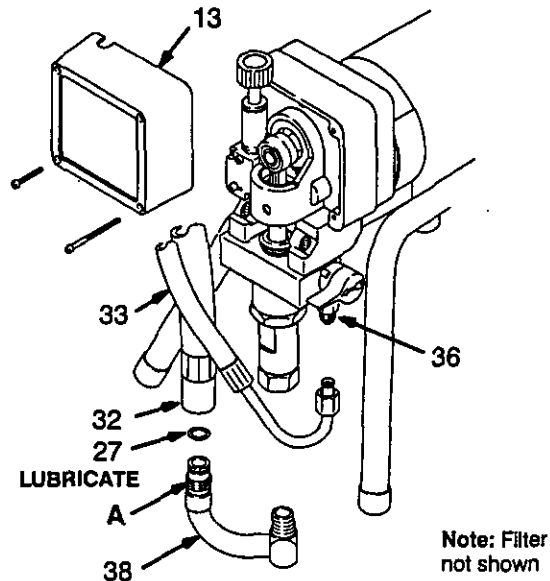

Fig 33

DRAIN VALVE

WARNING

To reduce the risk of serious injury, follow the **Pressure Relief Procedure Warning** on page 19 before doing this procedure. Unplug the sprayer!

1. Turn the handle (45) to the closed position. Drive out the pin (44). Remove the handle.
2. Remove the base (43).
3. Unscrew the drain valve (42). The gasket (42a) and seat (42b) will stay in the valve.

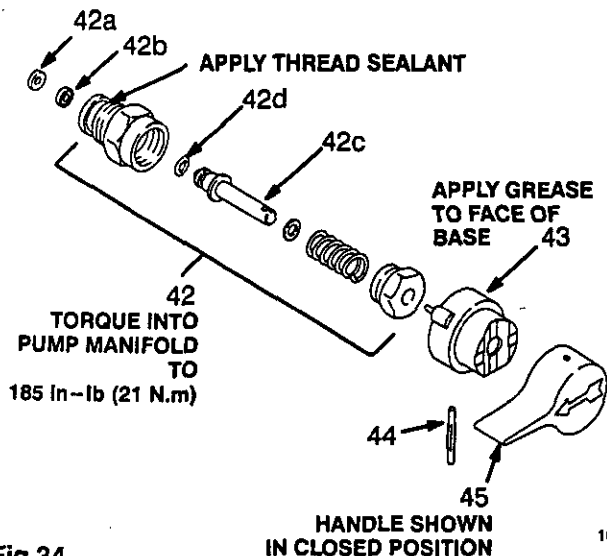

Fig 34

Repair

1. Unscrew the spring retainer from the valve body. Remove the spring, washers and stem/ball. Clean any debris from the ball or seat area.
2. If replacing the gasket (42a) or seat (42b), pry out the gasket.

NOTE 1: Whenever the gasket (42a) is removed, replace it with a new one.

3. Coat the o-ring (42e) with grease. Press the stem into the valve body. Install the spring, washers and spring retainer into the valve body.
4. Place the seat (42b) in the valve body so the lapped side is toward the ball. Apply a small amount of grease to the new gasket (42a) and install it in the valve body.

NOTE 2: The gasket will protrude from the end of the valve until the valve is tightened into pump, which correctly seats the gasket.

Replacement

1. Apply a small amount of thread sealant (42e) onto the valve (42) threads. Tighten the valve into the pump manifold to 185 in-lb (21 N.m).
2. Lightly grease the face of the base (43) and install the base. Turn the stem so the pin hole is vertical.
3. Securely install the handle (45) and drive the pin (44).

PARTS DRAWING & LIST – DISPLACEMENT PUMP

Model 235–699 Series A

Includes items 101 to 126

| Ref No. | Part No. | Description | Qty |
|---------|----------|------------------------------|-----|
| 101 | 187–611 | MANIFOLD, pump | 1 |
| 102 | 176–758 | NUT, packing | 1 |
| 103 | 176–757* | GLAND, female, throat | 1 |
| 104 | 176–997* | V–PACKING, plastic, throat | 3 |
| 105 | 176–755* | V–PACKING, leather, throat | 2 |
| 106 | 176–754* | GLAND, male, throat | 1 |
| 107 | 235–709 | ROD, displacement | 1 |
| 108 | 218–197 | PISTON, valve | 1 |
| 109 | 105–444* | BALL, 5/16", piston | 1 |
| 110 | 176–751 | NUT, hex, 1/2–20 unf–2b | 1 |
| 111 | 176–750* | GLAND, male, piston | 1 |
| 112 | 176–882* | V–PACKING, plastic, piston | 3 |
| 113 | 176–749* | V–PACKING, leather, piston | 2 |
| 114 | 180–073* | GLAND, female, piston | 1 |
| 115 | 235–708 | CYLINDER, pump | 1 |
| 116 | 108–526* | PACKING, o–ring, PTFE | 1 |
| 117 | 187–614 | NUT, jam, 1-3/8 18 unef–2b | 1 |
| 118 | 224–966 | VALVE, inlet | 1 |
| 119 | 111–603* | PACKING, o–ring, PTFE | 1 |
| 120 | 176–760 | GUIDE, ball | 1 |
| 121 | 105–445* | BALL, 1/2", inlet | 1 |
| 122 | 176–759* | PIN, ball stop | 1 |
| 123 | 180–656 | PLUG | 1 |
| 124 | 102–969* | SEALANT | 1 |
| 125 | 105–522* | PACKING, u-cup, polyurethane | 1 |
| 126 | 186–652* | WASHER, backup, aluminum | 1 |

***Supplied in Repair Kit 235–703.**
Keep a repair kit on hand to reduce down time.

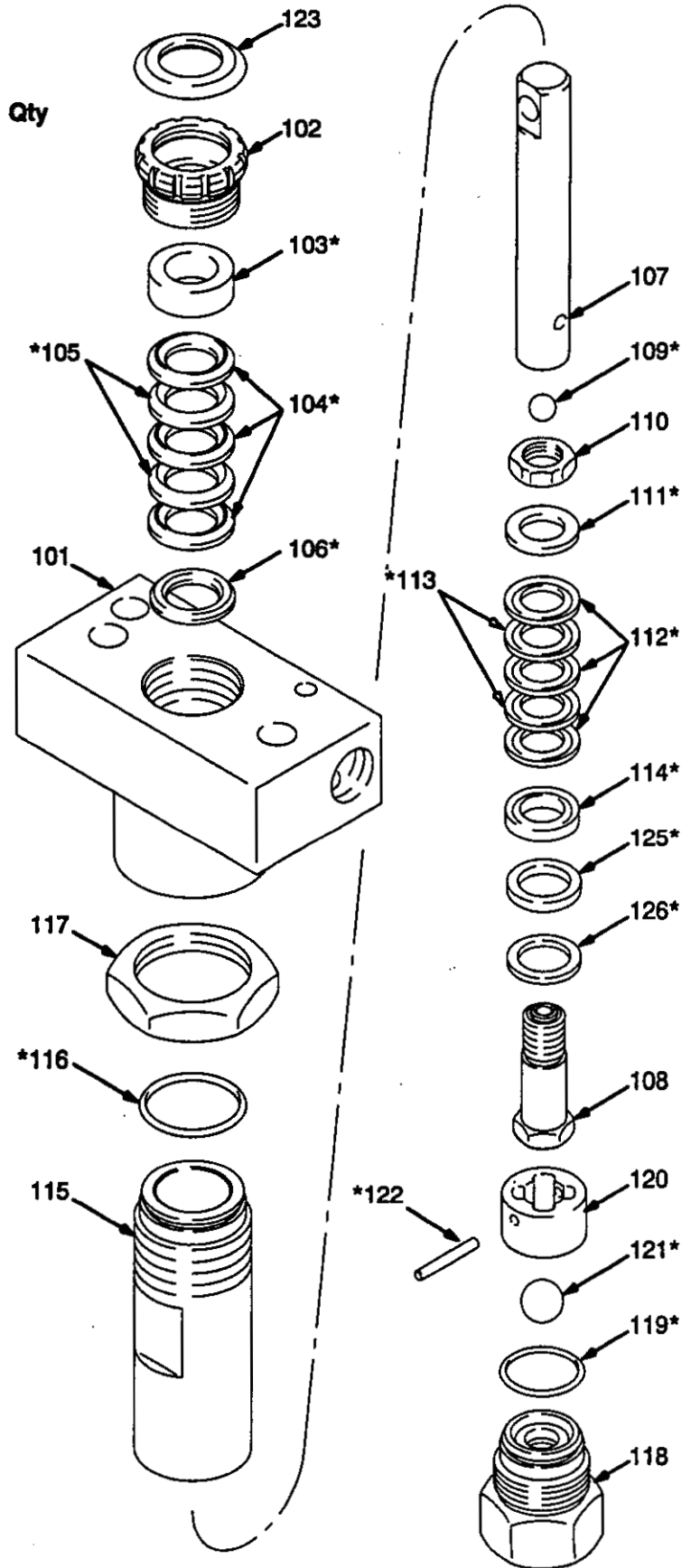

1708

PARTS - COMPLETE SPRAYER

Model 231-208, Series A

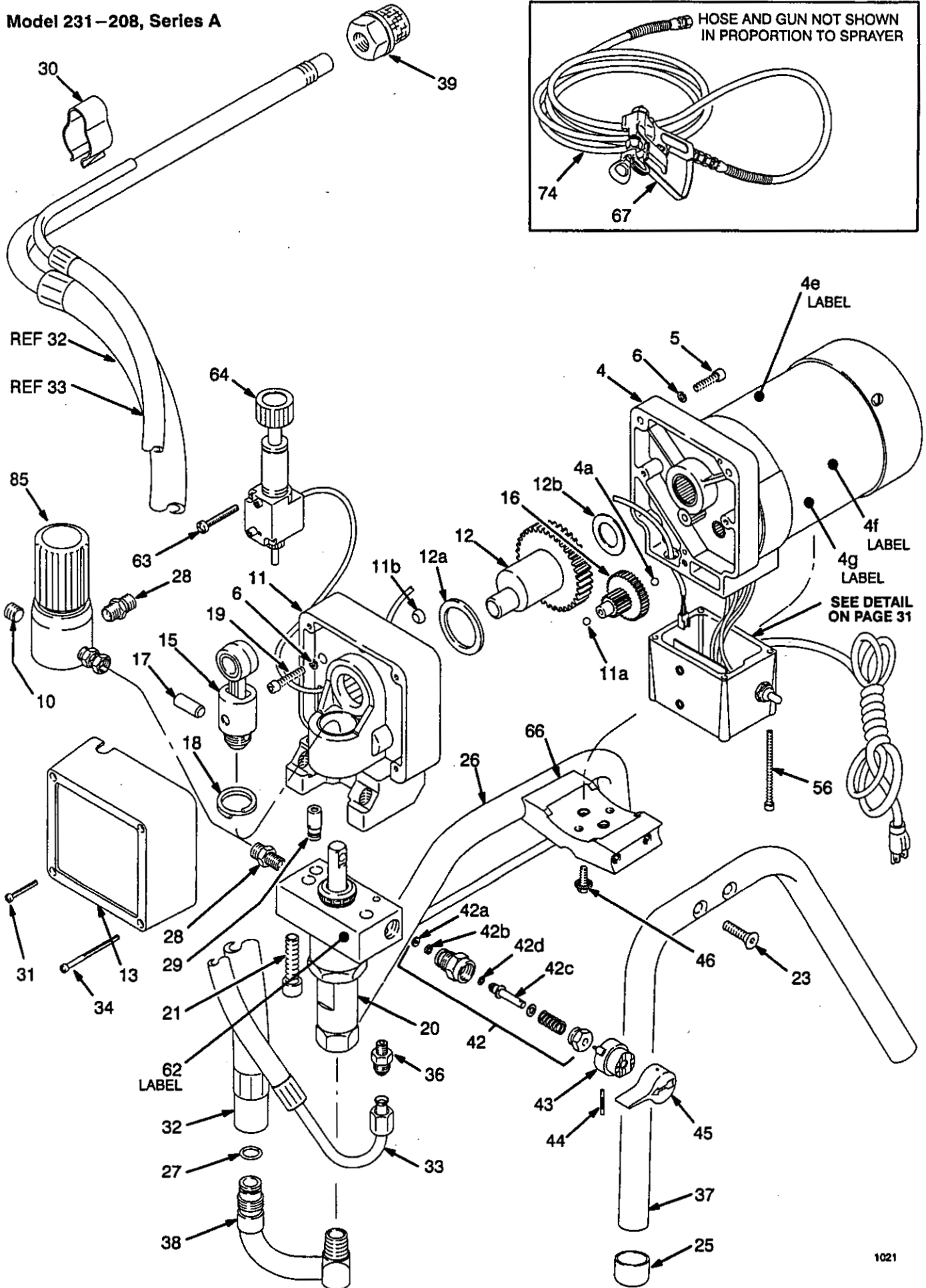
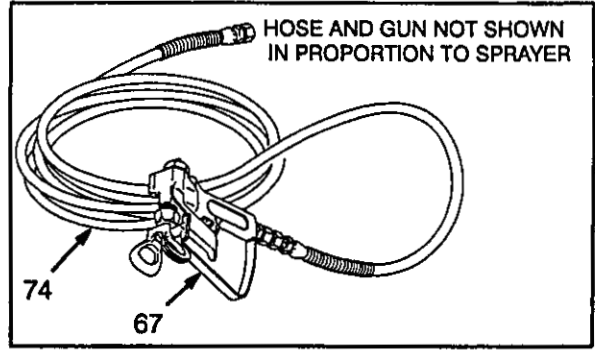

PARTS DRAWING – COMPLETE SPRAYER

Model 231–208, Series A
Includes items 3 to 85 as listed below

| Ref No. | Part No. | Description | Qty | Ref No. | Part No. | Description | Qty |
|---------|----------|---|-----|---------|----------|---|-----|
| 3 | 111-700 | GRIP, handle | 1 | 43 | 224-807 | BASE, valve | 1 |
| 4 | 235-698† | MOTOR KIT <i>Includes items 4a to 4f</i> | 1 | 44 | 111-600 | PIN, grooved, 3/32 x 1" | 1 |
| 4a | 100-069 | . BALL, SST, 1/4" dia. | 1 | 45 | 187-625 | HANDLE, drain valve | 1 |
| 4b | 111-616 | . TERMINAL, flat, 1/4" (f) | 2 | 46 | 110-997 | SCREW, washer/hex hd, 5/16" | 2 |
| 4c | 107-503 | . TERMINAL, 3/16" (m) | 2 | 47 | 235-707 | MOTOR START BOARD | 1 |
| 4e | 187-784* | . LABEL, DANGER, French | 1 | 48 | 186-620* | LABEL, ground terminal | 1 |
| 4f | 187-791* | . LABEL, DANGER, English | 1 | 49 | 110-037 | SCREW, mach, pnhd, 10-24 x 5/8" | 1 |
| 4g | 187-975* | . LABEL, Warning, Elec. Shock | 1 | 50 | 235-010 | POWER CORD SET | 1 |
| 5 | 100-643 | SCREW, sch, 1/4-20 x 1" | 2 | 51 | 111-617 | BUSHING, strain relief, 3/8-18 npt | 1 |
| 6 | 105-510 | LOCKWASHER, spring, 1/4" | 5 | 52 | 105-679 | SWITCH, ON/OFF | 1 |
| 10 | 100-721 | PLUG, 1/4 npt | 1 | 53 | 235-035 | GROUND HARNESS | 1 |
| 11 | 224-965 | DRIVE HOUSING KIT <i>Includes item 11a, 11b</i> | 1 | 54 | 105-658 | LOCKING RING | 1 |
| 11a | 100-069 | . BALL, stainless steel, 1/4" dia. | 1 | 55 | 105-659 | BOOT, switch | 1 |
| 11b | 111-726 | . PLUG | 1 | 56 | 111-703 | SCREW, filh, 10-24 x 3" | 4 |
| 12 | 224-803 | CRANKSHAFT <i>Includes items 12a, 12b</i> | 1 | 58 | 100-035 | SCREW, panhd, 8-32 x 5/16" | 2 |
| 12a | 181-131 | . BEARING, thrust | 1 | 59 | 187-795 | JUNCTION BOX | 1 |
| 12b | 107-434 | . BEARING | 1 | 62 | 183-466* | LABEL, Warning | 1 |
| 13 | 187-789 | COVER, front | 1 | 63 | 111-704 | SCREW, filh, 10-24 x 1-5/8" | 2 |
| 14 | 188-360* | LABEL, Warning | 1 | 64 | 224-828 | PRESSURE CONTROL KIT | 1 |
| 15 | 218-359 | ROD, CONNECTING | 1 | 66 | 187-770 | BASE, motor | 1 |
| 16 | 218-364 | GEAR REDUCER | 1 | 67 | 220-955 | CONTRACTOR GUN <i>See manual 307-614 for parts</i> | 1 |
| 17 | 176-818 | PIN, straight, hdls, 3/8" dia. x 1" | 1 | 68 | 206-994 | TSL, 8 oz. (not shown) | 1 |
| 18 | 176-817 | SPRING, retaining | 1 | 74 | 223-541 | HOSE, grounded, nylon; 1/4" ID; cpld 1/4 npsm(f); 50 ft (15 m); spring guards both ends | 1 |
| 19 | 103-345 | SCREW, sch, 1/4-20 x 1-1/4" | 3 | 85 | 235-677 | FLUID FILTER <i>see manual 308-249 for parts</i> | 1 |
| 20 | 224-999 | PUMP KIT <i>see parts on page 29</i> | 1 | | | | |
| 21 | 111-706 | CAPSCREW, sch, 7/16-14 x 1-3/4" | 2 | | | | |
| 23 | 111-715 | SCREW, special filh, 5/16-18 x 1-1/4" | 6 | | | | |
| 24 | 187-631 | HANDLE, sprayer | 1 | | | | |
| 25 | 111-611 | CAP, tubing | 4 | | | | |
| 26 | 235-037 | LEG, w/gusset | 1 | | | | |
| 27 | 104-938 | O-RING | 1 | | | | |
| 28 | 162-453 | NIPPLE, hex, 1/4 npsm x 1/4 npt, 1-3/16" | 2 | | | | |
| 29 | 235-009 | PRESSURE TRANSDUCER | 1 | | | | |
| 30 | 111-602 | CLIP, 3/4" | 1 | | | | |
| 31 | 108-850 | SCREW, filh, 8-32 x 1-1/4" | 1 | | | | |
| 32 | 187-624 | SUCTION HOSE & TUBE | 1 | | | | |
| 33 | 187-652 | DRAIN HOSE | 1 | | | | |
| 34 | 111-705 | SCREW, filh, 8-32 x 2-1/2" | 3 | | | | |
| 35 | 188-421 | LABEL, identification | 1 | | | | |
| 36 | 111-612 | ADAPTER, tube, 9/16-18 | 1 | | | | |
| 37 | 187-895 | LEG, sprayer | 1 | | | | |
| 38 | 187-627 | TUBE, inlet | 1 | | | | |
| 39 | 235-004 | STRAINER | 1 | | | | |
| 42 | 235-014 | DRAIN VALVE KIT <i>Includes items 42a to 42e</i> | 1 | | | | |
| 42a | 111-699 | . GASKET, valve seat | 1 | | | | |
| 42b | 187-615 | . SEAT, drain valve | 1 | | | | |
| 42c | 224-968 | . STEM, drain valve | 1 | | | | |
| 42d | 168-110 | . O-RING, stem | 1 | | | | |
| 42e | 110-110 | . SEALANT, pipe (not shown) | 1 | | | | |

*Extra warning labels available free of charge.

† Motor Brush and Spring Replacement Kit, P.N. 235-727 is available. Purchase separately.

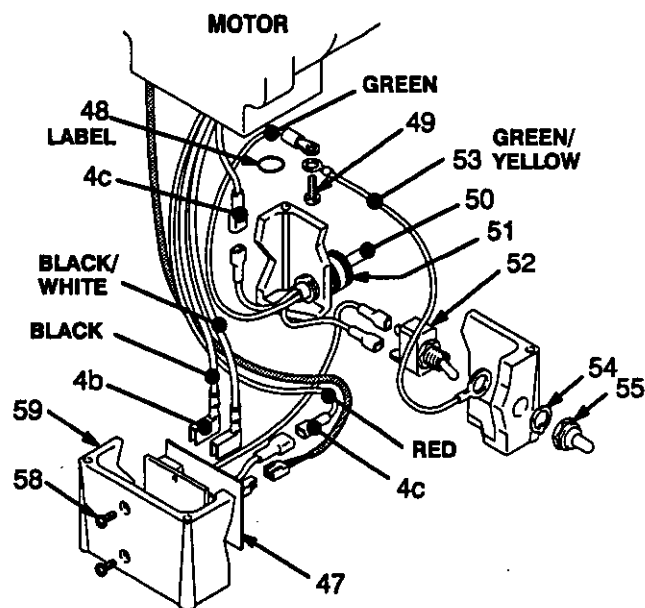

TECHNICAL DATA

Power Requirements 120 VAC, 60Hz,
1 phase, 15 amp minimum
Working Pressure Range 0-2750 psi (0 - 195 bar)
Motor 3/4 HP
Cycles/Gallon (liter) 620 (164)
Delivery 0.50 gpm (1.90 lpm)
Tip Size one gun to 0.017 tip
with latex at 2000 psi (138 bar)
Power Cord No. 14 AWG, 3 wire, 6' (1.8 m)
Inlet Paint Strainer 12 mesh (1525 micron)
Stainless Steel Screen, reusable
Outlet Filter 60 mesh (250 micron)
Pump Inlet Size 1/2 npt(f)
Fluid Outlet Size 1/4 npsm

Wetted Parts:

Displacement Pump Stainless steel, Carbon steel,
Aluminum, Polyethylene, Delrin®, Leather
Filter Aluminum, Steel, PTFE[®], Stainless steel
NOTE: Teflon and Delrin are trademarks of the Company.

PHONE NUMBERS

TO PLACE AN ORDER, contact your distributor, or call this number to identify the distributor closest to you: **1-800-328-0211 Toll Free**

FOR TECHNICAL ASSISTANCE, service repair information or assistance regarding the application of equipment: **1-800-543-0339 Toll Free**

DIMENSIONS

Weight (dry w/o packaging) 36.5 lb (17 kg)
Height 19 in. (483 mm)
Length 15 in. (381 mm)
Width 14 in. (356 mm)

ACCESSORIES

DANGER LABELS

The English language DANGER label shown on page 1 is also on your sprayer. If you have painters who do not read English, order one of the following labels to apply to your sprayer. The drawing below shows the best placement of these labels for good visibility.

Order the labels directly from Graco, free of charge:
1-800-328-0211

| | |
|---------|---------|
| French | 187-784 |
| Spanish | 185-956 |
| German | 185-961 |
| Greek | 186-041 |
| Korean | 186-045 |
| English | 187-791 |

Apply other language here

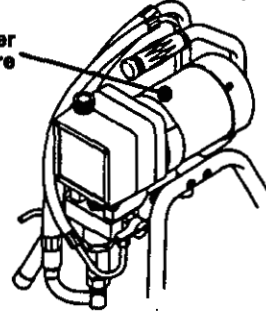

THE GRACO WARRANTY AND DISCLAIMERS

WARRANTY

Graco warrants all equipment manufactured by it and bearing its name to be free from defects in material and workmanship on the date of sale by an authorized Graco distributor to the original purchaser for use. As purchaser's sole remedy for breach of this warranty, Graco will, for a period of twelve months from the date of sale, repair or replace any part of the equipment proven defective, with the exception of defects in parts on the drive train/gear box on EM and GM sprayers or power train on EH and GH sprayers, which will be repaired or replaced for twenty-four months from the date of sale for Gas-Hydraulic (GH) and Gas-Mechanical (GM) sprayers and for thirty-six months from the date of sale for Electric-Mechanical (EM), Electric-Hydraulic (EH), 390st and 490st sprayers. This warranty applies only when the equipment is installed, operated and maintained in accordance with Graco's written recommendations.

This warranty does not cover, and Graco shall not be liable for, any malfunction, damage or wear caused by faulty installation, misapplication, abrasion, corrosion, inadequate or improper maintenance, negligence, accident, tampering, or substitution of non-Graco component parts. Nor shall Graco be liable for malfunction, damage or wear caused by the incompatibility with Graco equipment of structures, accessories, equipment or materials not supplied by Graco, or the improper design, manufacture, installation, operation or maintenance of structures, accessories, equipment or materials not supplied by Graco.

This warranty is conditioned upon the prepaid return of the equipment claimed to be defective to an authorized Graco distributor for verification of the claim. If the claimed defect is verified, Graco will repair or replace free of charge any defective parts. The equipment will be returned to the original purchaser transportation prepaid. If inspection of the equipment does not disclose any defect in material or workmanship, repairs will be made at a reasonable charge, which charges may include the costs of parts, labor and transportation.

DISCLAIMERS AND LIMITATIONS

The terms of this warranty constitute purchaser's sole and exclusive remedy and are in lieu of any other warranties (express or implied), including warranty of merchantability or warranty of fitness for a particular purpose, and of any non-contractual liabilities, including product liabilities, based on negligence or strict liability. Every form of liability for direct, special or consequential damages or loss is expressly excluded and denied. In no case shall Graco's liability exceed the amount of the purchase price. Any action for breach of warranty must be brought within two (2) years of the date of sale.

EQUIPMENT NOT COVERED BY GRACO WARRANTY

Graco makes no warranty, and disclaims all implied warranties of merchantability and fitness for a particular purpose, with respect to accessories, equipment, materials, or components sold but not manufactured by Graco. These items sold, but not manufactured by Graco (such as electric motor, switches, hose, etc.) are subject to the warranty, if any, of their manufacturer. Graco will provide purchaser with reasonable assistance in making any claim for breach of these warranties.

Factory Branches: Atlanta, Dallas, Detroit, Los Angeles, Mt. Arlington (N.J.)

Subsidiary and Affiliate Companies: Canada; England; Korea, Switzerland; France; Germany; Hong Kong; Japan

GRACO INC. P.O. BOX 1441 MINNEAPOLIS, MN 55440-1441

PRINTED IN U.S.A. 308-248 11-92