

# Instructions – Parts List



AIR OPERATED, WATERBASE COMPATIBLE

308266C

## DynaMite™ Dispense Valves

**Maximum Fluid Viscosity: 600,000 Centipose**

*900 psi (63 bar) Maximum Fluid Working Pressure  
100 psi (7 bar) Maximum Air Input Pressure*

### Model 224906, Series A

Dispense Valve

### Model 235877

Dispense Valve with Handle

Patent Pending

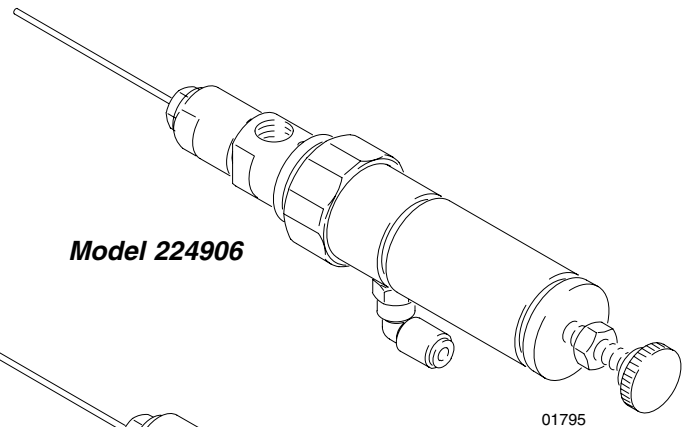

**Model 224906**

01795

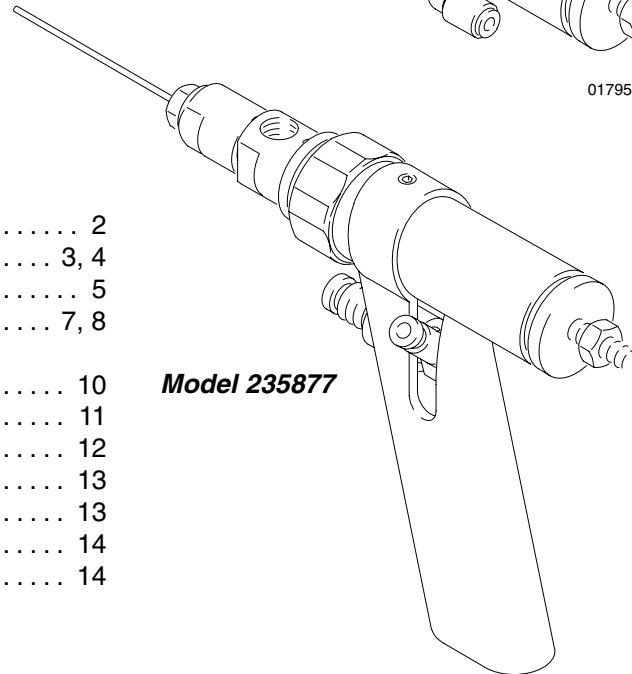

**Model 235877**

01796

## Contents

|                         |      |
|-------------------------|------|
| Warnings .....          | 2    |
| Installation .....      | 3, 4 |
| Operation .....         | 5    |
| Service .....           | 7, 8 |
| Parts                   |      |
| Model 224906 .....      | 10   |
| Model 235877 .....      | 11   |
| Accessories .....       | 12   |
| Dimensions .....        | 13   |
| Technical Data .....    | 13   |
| Graco Warranty .....    | 14   |
| Graco Information ..... | 14   |



### Important Safety Instructions

Read all warnings and instructions in this manual.  
Save these instructions.

# Symbols

## Warning Symbol



This symbol alerts you to the possibility of serious injury or death if you do not follow the instructions.

## Caution Symbol



This symbol alerts you to the possibility of damage to or destruction of equipment if you do not follow the instructions.

## ! WARNING



### SKIN INJECTION HAZARD

High-pressure fluid from gun, hose leaks, or ruptured components will pierce skin. This may look like just a cut, but it is a serious injury that can result in amputation. **Get immediate surgical treatment.**

- Do not point dispense valve at anyone or at any part of the body.
- Do not put your hand over the end of the dispense nozzle.
- Do not stop or deflect leaks with your hand, body, glove, or rag.
- Follow **Pressure Relief Procedure** in this manual, when you stop spraying and before cleaning, checking, or servicing equipment.



### EQUIPMENT MISUSE HAZARD

Misuse can cause death or serious injury.

- Do not exceed the maximum working pressure or temperature rating of the lowest rated system component. See **Technical Data** in all equipment manuals.
- Use fluids and solvents that are compatible with equipment wetted parts. See **Technical Data** in all equipment manuals. Read fluid and solvent manufacturer's warnings.
- Check equipment daily. Repair or replace worn or damaged parts immediately.
- Do not alter or modify equipment.
- For professional use only.
- Use equipment only for its intended purpose. Call your Graco distributor for information.
- Route hoses and cables away from traffic areas, sharp edges, moving parts, and hot surfaces.
- Do not use hoses to pull equipment.
- Comply with all applicable safety regulations.

# Installation

**NOTE:** Read and understand this entire manual before operating the Dispense Valve.

**NOTE:** The dispense valve requires a minimum air inlet pressure of 40 psi (2.8 bar).

## Mounting Accessories

### Mounting Stand Kit

Mounting Stand 235270 is available for applications requiring mounting the valve in a fixed position. The kit includes instructions. See **Accessories** on page 12.

### Foot Valve Kit

Foot Valve 235830 enables the operator to trigger the dispense valve with a foot pedal. The kit includes instructions. See **Accessories** on page 12.

### Handle Kit

Handle Kit 235269 is available to convert Model 224906 Dispense Valve to Model 235877. The kit includes instructions. See **Accessories** on page 12.

## Installing the Needle Nozzle

**NOTE:** This dispense valve is supplied with two needle nozzle sizes (.047 in. and .063 in. I.D.). Other sizes are available (see page 12).

**To install needle nozzles 112000 through 112007,** wrap the threads of the needle nozzle with PTFE tape and screw the needle nozzle (14) securely into the housing (12). See Fig. 1.

**NOTE:** When removing a needle nozzle, hold the needle nozzle housing (12) with a wrench to keep it from moving. Using another wrench, remove the needle nozzle (14) from the housing.

**NOTE:** Other needle nozzle sizes are available (see **Accessories** on page 12). To use these needle nozzles, you must also purchase Needle Adapter 109599. **To install these needle nozzles,** wrap the threads of the 109599 needle adapter with PTFE tape and screw the adapter securely into the needle nozzle housing (12). Push the needle nozzle into the adapter and turn clockwise to lock.

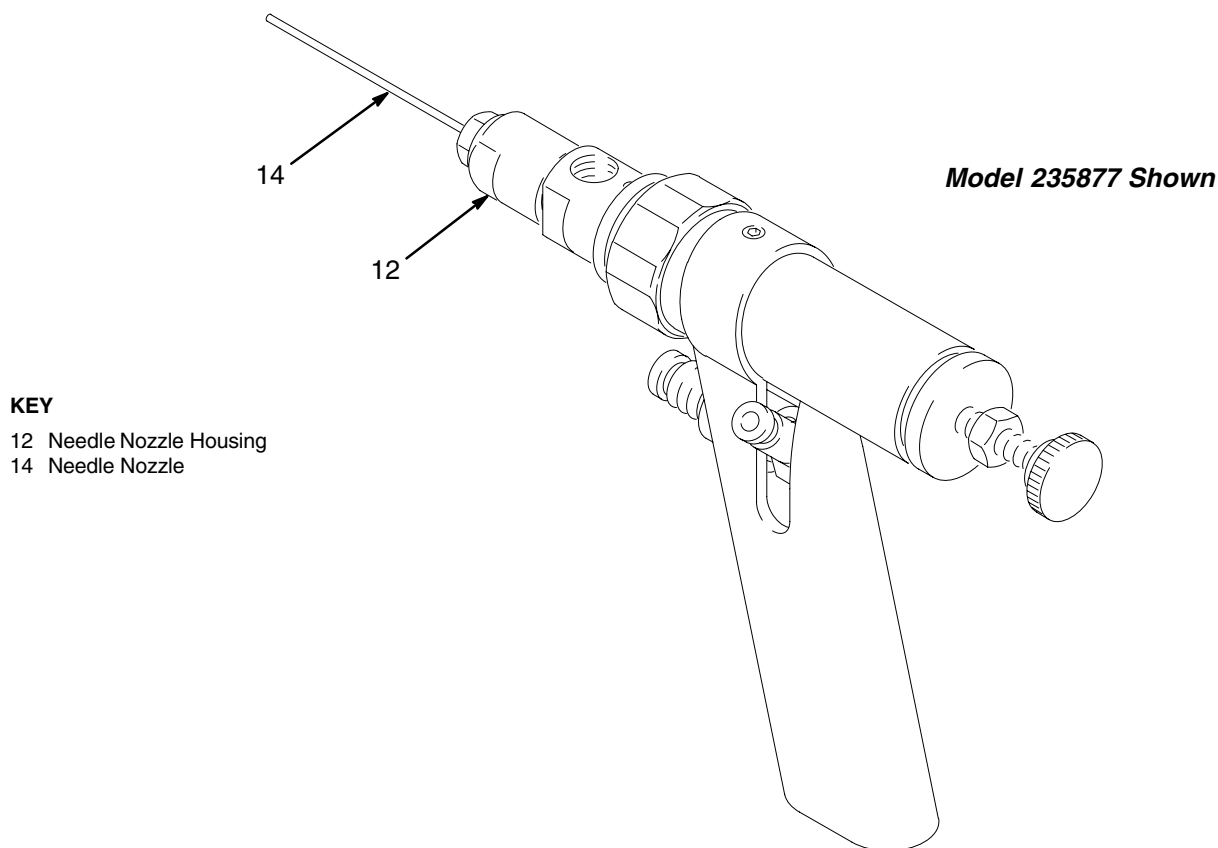

Fig. 1

01796

# Installation

## Connecting the Air and Fluid Lines

**NOTE:** To change the relative positions of the fluid inlet (C) and air fitting (10 or 106), loosen the valve housing swivel (11), reposition the fluid inlet, and re-tighten.

1. Connect the air supply tube (A) to the air inlet fitting (10 or 106) by pushing the tube straight into the fitting until it seats. To check that the tube is secure, pull back on it gently, to ensure that it will not pull out. See Fig. 2.

**NOTE:** If cutting the tube, cut it at 90°, being careful not to damage the outer diameter of the tube. Use of a tube cutter is recommended. The fitting will leak if the tubing is not cut at 90°.

2. Connect the fluid line (B) to the 1/8 npt(f) fluid inlet (C) of the dispense valve. For convenience, use hose ties (E) to fasten the fluid line and air line together.

**NOTE:** Fluid Hose Kits are available. See **Accessories** on page 12. The kits include a length of hose (B) and a fluid inlet swivel (D).

### KEY

- 10 Air Inlet Fitting (Model 224906)
- 11 Valve Housing (Swivel)
- 106 Air Inlet Fitting (Model 235877)
- A Air Supply Line (not supplied)
- B Fluid Supply Line (not supplied)
- C Fluid Inlet
- D Fluid Inlet Swivel (not supplied)
- E Hose Tie (not supplied)

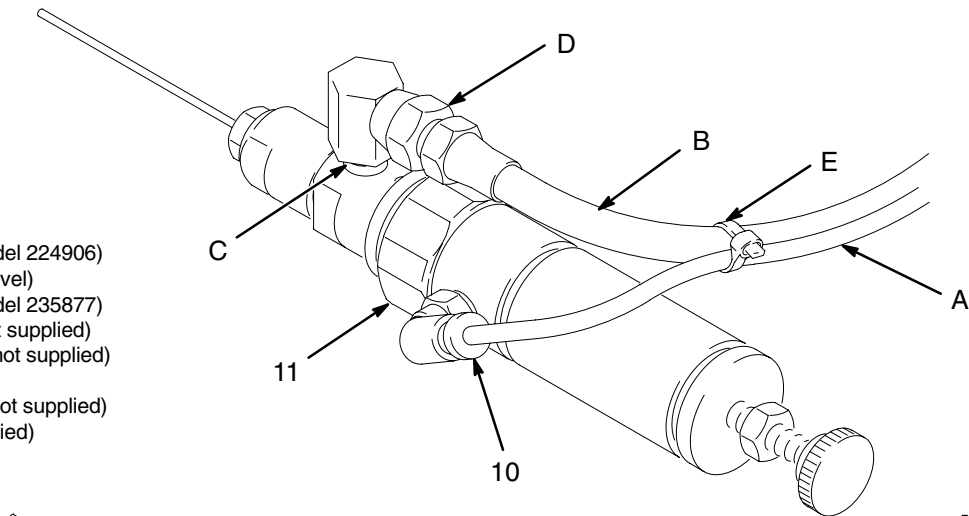

02169

**Model 224906**  
*(shown with air line and optional fluid hose kit installed)*

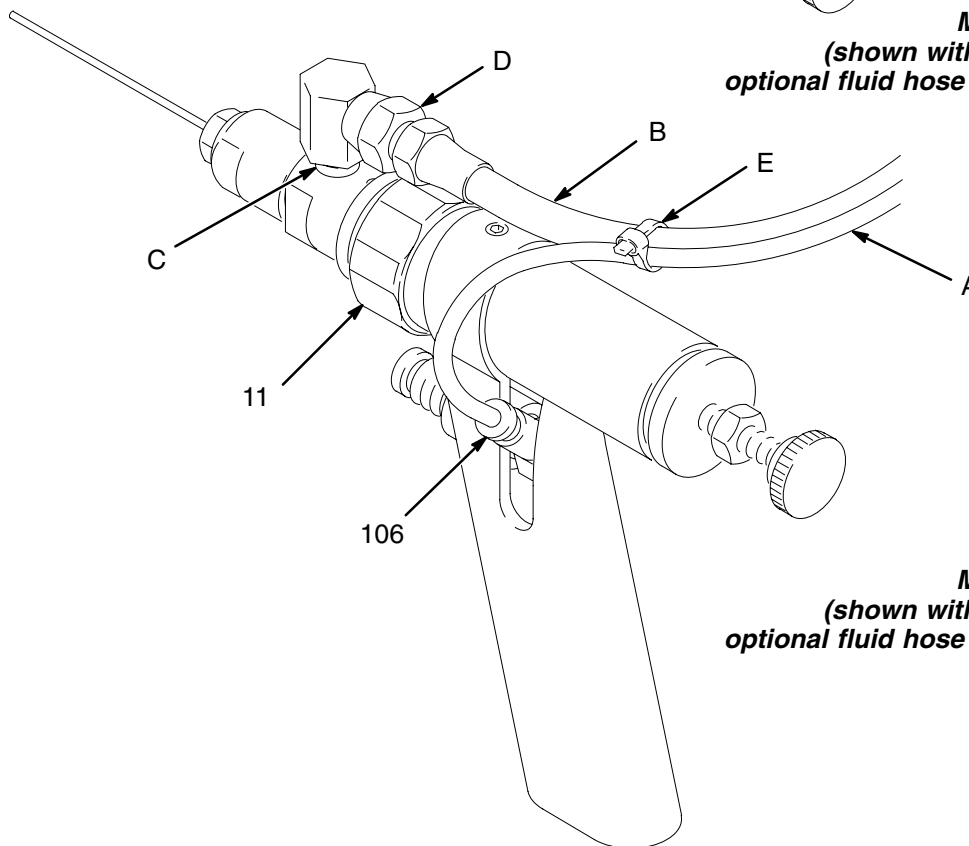

**Model 235877**  
*(shown with air line and optional fluid hose kit installed)*

01797

# Operation

## Pressure Relief Procedure

### **WARNING**

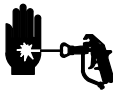

#### **SKIN INJECTION HAZARD**

The system pressure must be manually relieved to prevent the system from starting or spraying accidentally. Fluid under high pressure can be injected through the skin and cause serious injury. To reduce the risk of an injury from injection, splashing fluid, or moving parts, follow the **Pressure Relief Procedure** whenever you:

- are instructed to relieve the pressure,
- stop spraying,
- check or service any of the system equipment,
- or install or clean the spray tips.

1. Shut off the air and fluid supply to the dispense valve.
2. Point the valve into a pail, and trigger the valve to relieve pressure.
3. *If you suspect that the needle nozzle or hose is completely clogged or that pressure has not been fully relieved after following the steps above, very slowly loosen the needle nozzle or hose end coupling and relieve pressure gradually, then loosen completely. Now clean the needle nozzle or hose.*

# Operation

## ⚠ WARNING

To reduce the risk of overpressurization which can cause component rupture and serious injury, never exceed 900 psi (63 bar) fluid pressure or 100 psi (7 bar) air pressure to the dispense valve.

### Starting and Adjusting the Flow

1. Open the air (A) and fluid (B) supply lines to the dispense valve.
2. Trigger the dispense valve until fluid begins to flow evenly from the needle nozzle (14) and all air is expelled from the system. Close the valve to stop the flow. The valve and fluid line are now primed. See Fig. 3.

**NOTE:** When using a foot valve kit (see page 12), press the foot pedal to trigger the dispense valve, and release the pedal to stop the flow. On Model 235877 Dispense Valve, press the trigger (G) to open the valve, and release to stop the flow.

3. To adjust the flow and bead size, make the following adjustments in the order given:

- a. Adjust the fluid inlet pressure to the valve to get the desired results.
- b. To change the bead width or shot size, or to adjust for heavier or lighter viscosity fluids, change to a different size needle nozzle (see page 12 for available sizes).
- c. For finer adjustments, turn the adjustment knob (6) to the right. To maintain the desired setting, tighten the lock nut (8).

**NOTE:** Time-pressure Controller 692018 is available for precision dispensing of very small quantities of fluid. See page 12 to order.

### Shutdown

1. Always follow the **Pressure Relief Procedure** on page 5 whenever you stop dispensing, even for only a short time.
2. When the dispense valve is not in use, remove the needle nozzle (14) or place a cork over the tip (see Fig. 3).
3. Never soak the entire dispense valve in solvent. Disconnect the fluid section from the air section by unscrewing the valve housing (11). Soak only the fluid section (F).

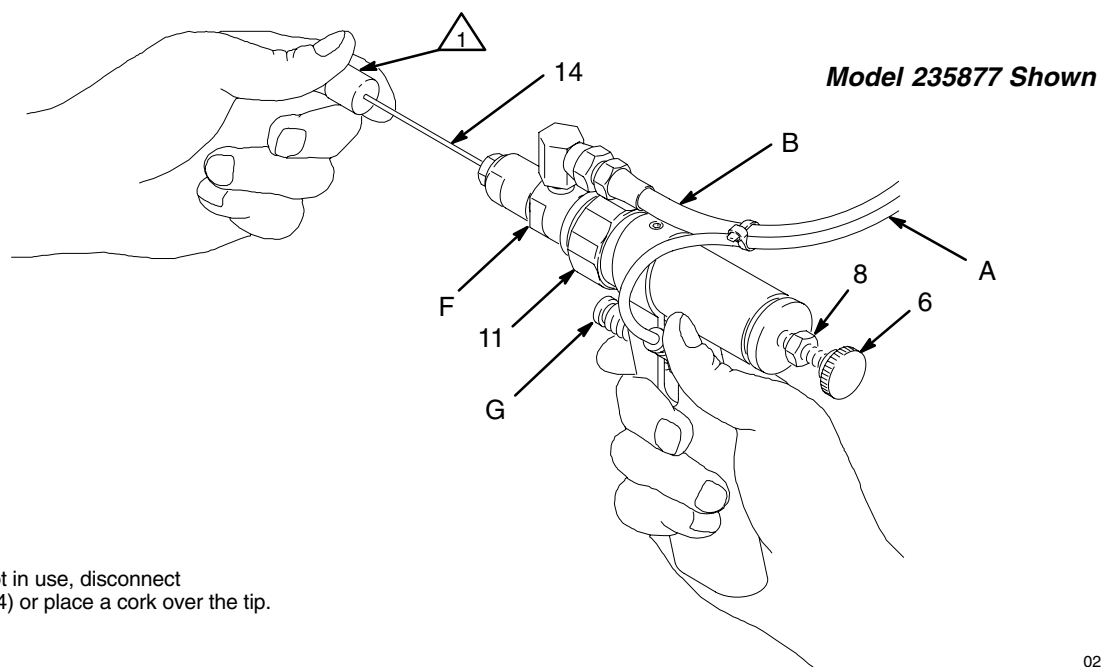

#### KEY

- 6 Adjustment Knob
- 8 Lock Nut
- 11 Valve Housing
- 14 Needle Nozzle
- A Air Line
- B Fluid Line
- F Fluid Section
- G Trigger

⚠ 1 When valve is not in use, disconnect needle nozzle (14) or place a cork over the tip.

Fig. 3

02273

# Service

## WARNING

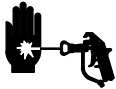

### SKIN INJECTION HAZARD

To reduce the risk of serious injury, follow the **Pressure Relief Procedure** on page 5 before checking or servicing any part of the system and whenever you are instructed to relieve the pressure.

To reduce the risk of a puncture wound, hold the valve securely, and keep your hands away from the needle nozzle when operating the valve.

## Tools Required

- Adjustable Wrenches
- Torque Wrench
- 1/4 in. (6 mm) Diameter Rod
- Flat Blade Screwdriver
- O-ring Pick
- PTFE Tape
- Medium Strength Thread Sealant

## Disassembly

**NOTE:** Repair Kit 235272 is available to service the dispense valve. For the best results, use all the parts in the kit, even if the old parts look good. Parts included in the kit are marked with an asterisk, for example (1\*).

1. Shut off the fluid supply. Follow the **Pressure Relief Procedure** on page 5.
2. Disconnect the air and fluid lines to the dispense valve.
3. Using a wrench on the flats, unscrew the needle nozzle housing (12) from the valve housing (11). See Fig. 4.

**NOTE:** To change the needle nozzle, see page 3.

4. Using a wrench, unscrew the valve housing (11) from the cylinder (9). Pull the housing away from the cylinder, being careful not to damage the valve needle (1) which is attached to the cylinder.

5. Pull the valve seat (13) out of the valve housing (11). Inspect the seat for wear.

**NOTE:** The valve seat (13) is reversible.

6. Unscrew the packing retainer (4) from the valve housing (11) with a flat blade screwdriver. Using an o-ring pick, remove the u-cup packing (3) from the housing. Clean the housing in a compatible solvent.
7. Inspect the valve needle (1) for scoring or damage. **If damaged**, unscrew it from the cylinder (9).

## Reassembly

1. Apply medium strength sealant to the threads of the valve needle (1\*), and screw it into the cylinder (9) until it bottoms out. Torque to 6–10 in–lb (0.7–1.1 N.m).
2. Lubricate the PTFE u-cup (3\*). Using a 1/4 in. (6 mm) diameter rod, gently work the u-cup into the valve housing (11) until it seats, *with the lips facing into the housing*.
3. Apply medium strength sealant to the threads of the packing retainer (4\*) and screw it into the valve housing (11) until it bottoms out. Torque to 20–30 in–lb (2.3–3.4 N.m).
4. Orient the air inlet fitting (A) and the fluid inlet (C) in any position you wish, relative to each other. Join the cylinder (9) and valve housing (11), carefully guiding the needle (1\*) into the valve housing (11) and through the u-cup (3\*). Screw the valve housing (11) onto the cylinder (9), handtight.
5. Insert the valve seat (13\*) into the male end of the valve housing (11) until it bottoms out.
6. Apply medium strength sealant to the threads of the needle nozzle housing (12) and screw it onto the valve housing (11). Torque to 20–30 in–lb (2.3–3.4 N.m).









**NOTE:** If the needle nozzle (14) was removed from the housing (12), replace as explained on page 3.

7. Reconnect the air and fluid lines to the dispense valve.

# Service

## KEY

- 1 Valve Needle
- 3 PTFE U-Cup Packing
- 4 Packing Retainer
- 6 Adjustment Knob
- 7 Adjustment Screw
- 8 Lock Nut
- 9 Cylinder
- 11 Valve Housing
- 12 Needle Nozzle Housing
- 13 Valve Seat
- 14 Needle Nozzle
- A Air Inlet Fitting (Model 224906 Shown)
- C Fluid Inlet

-  Apply PTFE tape.
-  Apply sealant.
-  Lubricate.
-  Torque to 20–30 in–lb (2.3–3.4 N.m).
-  Torque to 6–10 in–lb (0.7–1.1 N.m).
-  Seat is reversible.
-  Lips must face into housing (11).
-  Inspect weep hole for buildup of fluid, which could indicate a leaking u-cup (3).

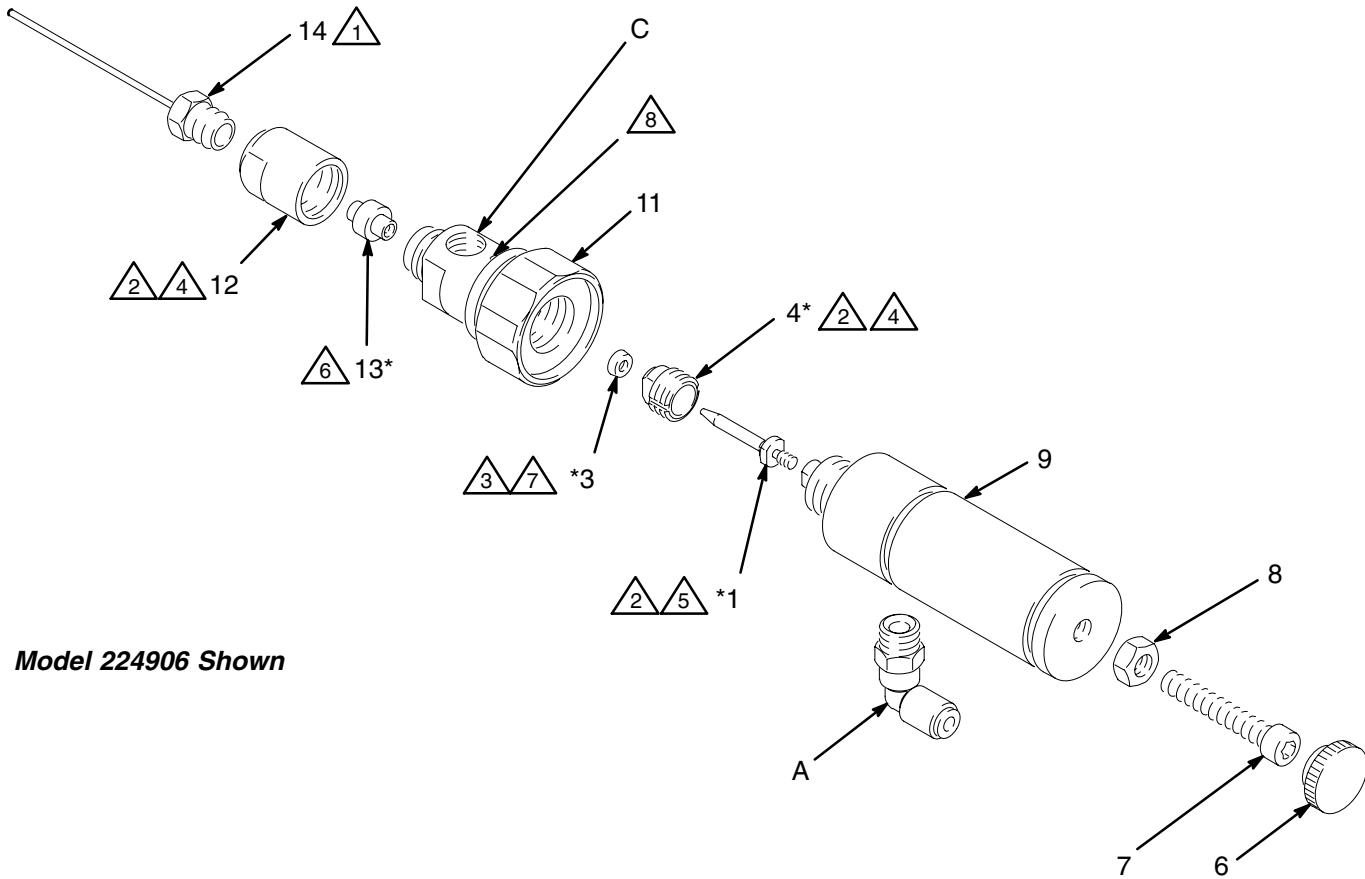

**Model 224906 Shown**

01798

**Fig. 4**



# Notes

---

---

---

---

---

---

---

---

---

---

---

---

---

---

---

---

---

---

---

---

---

---

---

---

---

---

---

---

# Parts

## Model 224906, Series A Dispense Valve Includes items 1–14

| Ref No. | Part No. | Description   | Qty | Ref No. | Part No. | Description  | Qty |
|---------|----------|---|-----|---------|----------|--|-----|
| 1*      | 187588   | NEEDLE, valve; stainless steel                                  | 1   | 12      | 188287   | HOUSING, needle nozzle; stainless steel                            | 1   |
| 3*      | 111288   | PACKING, u-cup; graphite-filled                                 | 1   | 13*     | 187587   | SEAT, valve; acetal  | 1   |
| 4*      | 187590   | PTFE w/stainless steel spring                                   | 1   | 14†     | 112000   | NOZZLE, needle; stainless steel; .047 in. (1.19 mm) ID; 1/8 npt(m) | 1   |
| 5▲      | 188288   | RETAINER, packing; carbon steel                                 | 1   |         | 112001   | NOZZLE, needle; stainless steel; .063 in. (1.60 mm) ID; 1/8 npt(m) | 1   |
| 6       | 111870   | LABEL, warning  | 1   |         |          |  |     |
| 7       | 111534   | KNOB, screw   | 1   |         |          |  |     |
|         |          | SCREW, cap, socket hd; 1/4–28 unf–3a x 1.5 in. (38 mm) long     | 1   |         |          |  |     |
| 8       | 100070   | NUT, hex; 1/4–28  | 1   |         |          |  |     |
| 9       | 187593   | CYLINDER, air; stainless steel and aluminum alloy; buna-N seals | 1   |         |          |  |     |
| 10      | 198171   | TUBE FITTING, elbow; 90°; 1/8 npt(m) x 0.156 in. (4 mm) OD tube | 1   |         |          |  |     |
| 11      | 235358   | HOUSING, valve, w/swivel nut; stainless steel wetted section    | 1   |         |          |  |     |

\* These parts are included in Repair Kit 235272, which may be purchased separately.

† Additional needle nozzle sizes are available as accessories. See page 12.

▲ Replacement Warning labels are available at no cost.

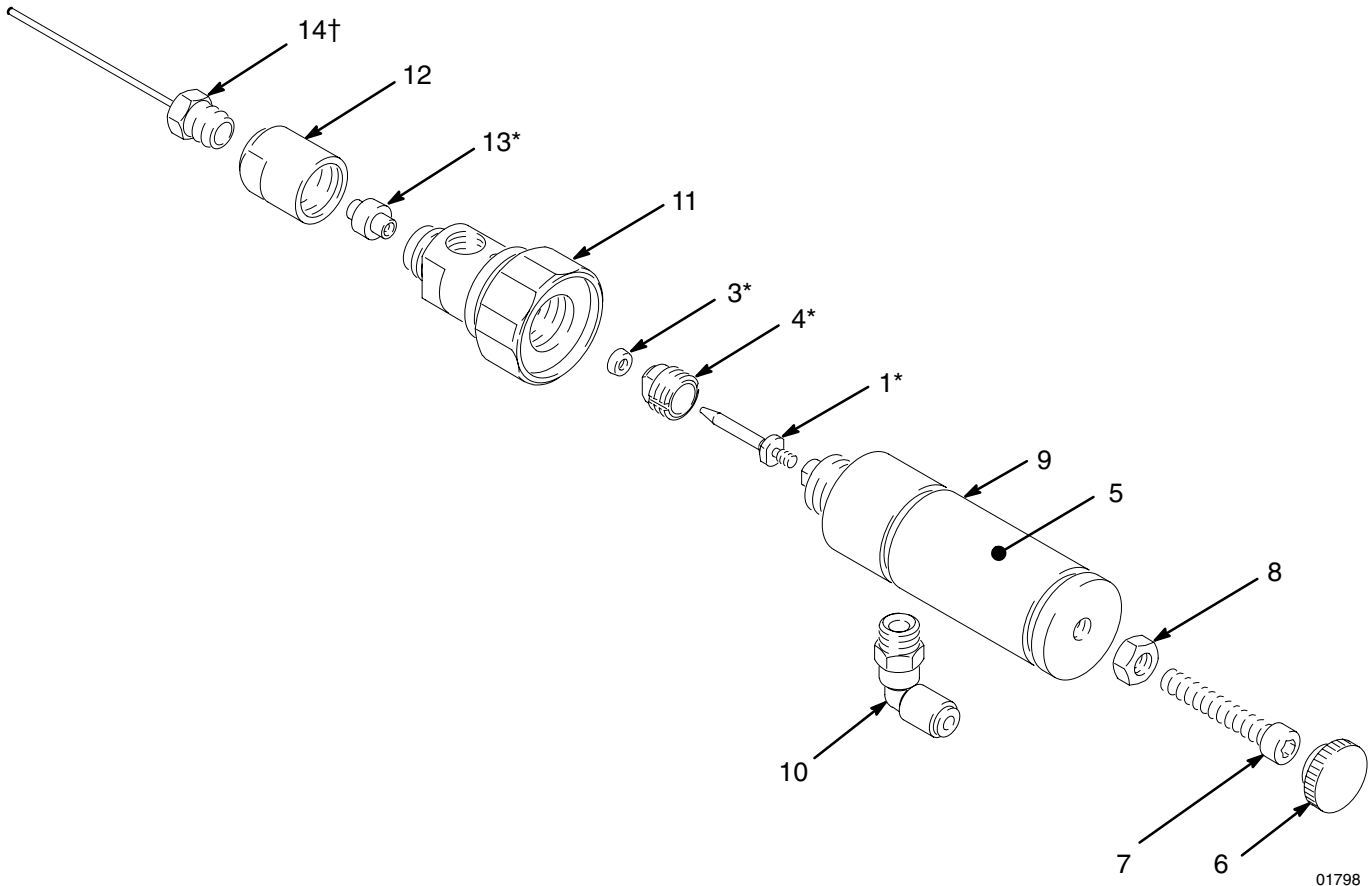

01798

# Parts

## Model 235877

### Dispense Valve with Handle

Includes items 101–109

| Ref No. | Part No. | Description   | Qty |
|---------|----------|---|-----|
| 101     | 224906   | DISPENSE VALVE<br>See page 10 for parts   | 1   |
| 102     | 235269   | HANDLE KIT<br>Includes items 103–109  | 1   |
| 103     | 235879   | . HANDLE  | 1   |
| 104     | 110914   | . VALVE   | 1   |
| 105     | 188720   | . FITTING, dispense valve   | 1   |
| 106     | 112253   | . CONNECTOR, tube;<br>3/32 in. internal hex; 10–32 unf–2a<br>x 0.156 in. (4 mm) OD tube | 1   |
| 107     | 112095   | . SCREW, set; 3/32 in.  | 1   |
| 108     | 111240   | . TUBE, air; nylon;<br>0.156 in. (4 mm) OD; 9 ft (2.7 m) long                           | 1   |
| 109     | 112097   | . WASHER; buna-N  | 1   |

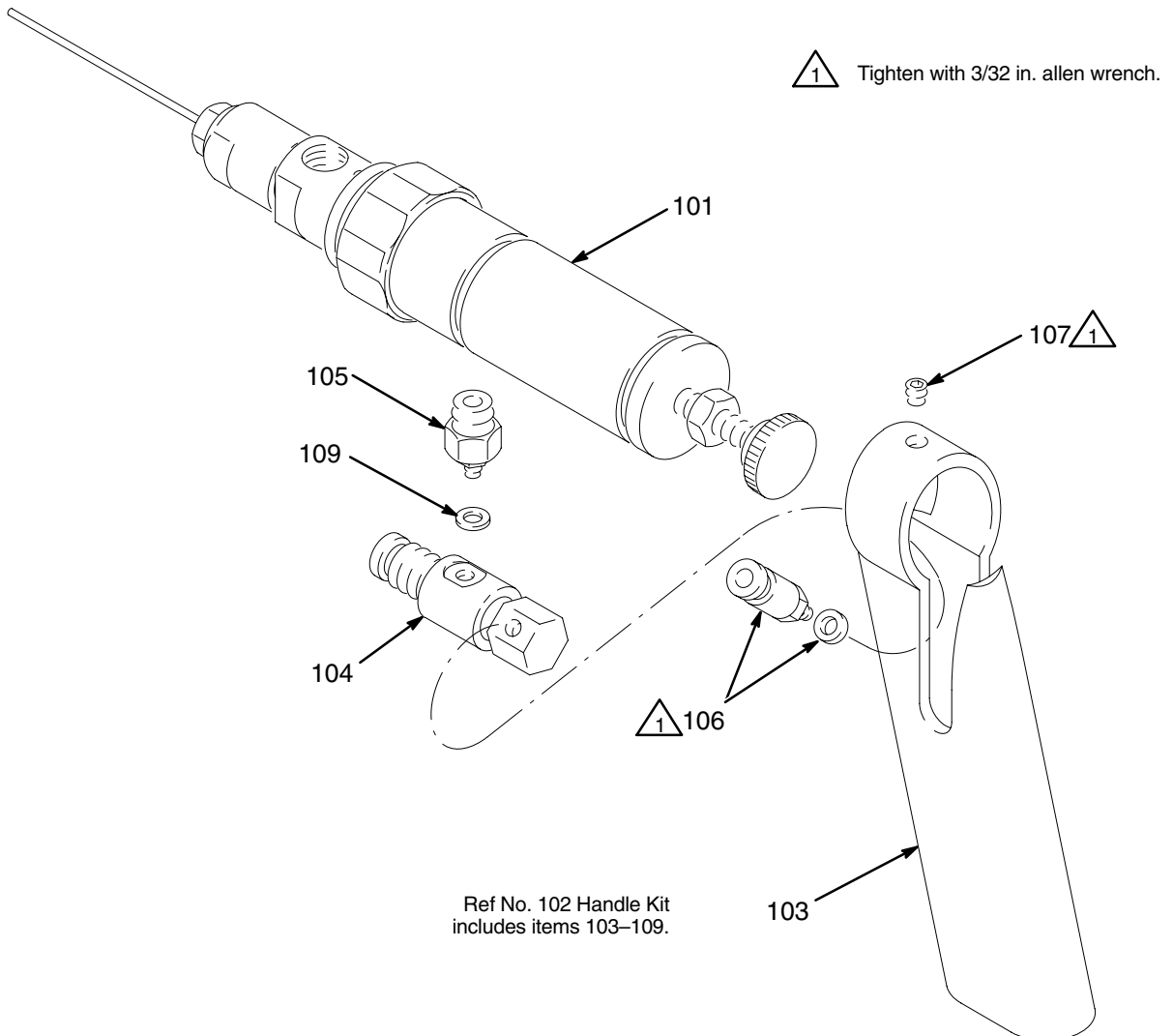

# Accessories

*Use Only Genuine Graco Parts and Accessories*

## Static Groundable Fluid Hose Kits

3000 psi (210 bar) Maximum Working Pressure  
PTFE core hose, stainless steel braid reinforcement;  
1/4 in. (6 mm) I.D., coupled 1/4 npt(m) x 1/8 npt(m),  
4 ft (1.2 m) long. Includes 90° swivel, 1/8 npt (m x f).

## 235271 Hose Kit (Carbon Steel Fittings)

## Time-Pressure Controller 692018

For precision dispensing of very small quantities of fluid.

## Foot Valve 235830

Enables operator to activate dispense valve with a foot switch.

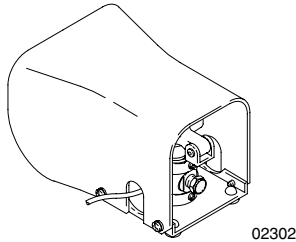

02302

## Dispense Valve Handle 235269

Pistol-grip handle mounts on the valve body. Converts Model 224906 Valve to Model 235877.

## Mounting Stand 235270

Enables mounting dispense valve in a fixed location.

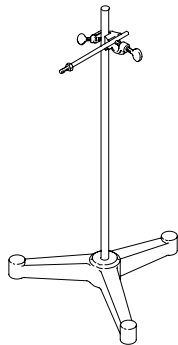

01803

## Dispense Needle Nozzles

Screw directly into the needle nozzle housing on the dispense valve. 1/8 npt(m), 2.5 in. (63.5 mm) long. Chrome plated brass; stainless steel wetted parts.

| Part No. | O.D. inches (mm) | I.D. inches (mm) | Needle Gauge |
|----------|------------------|------------------|--------------|
| 112000*  | .065 (1.65)      | .047 (1.19)      | 16           |
| 112001*  | .083 (2.11)      | .063 (1.60)      | 14           |
| 112002   | .095 (2.41)      | .071 (1.80)      | 13           |
| 112003   | 0.109 (2.77)     | .085 (2.16)      | 12           |
| 112004   | 0.120 (3.05)     | .094 (2.39)      | 11           |
| 112005   | 0.134 (3.40)     | 0.106 (2.69)     | 10           |
| 112006   | 0.165 (4.19)     | 0.135 (3.43)     | 8            |
| 112007   | 0.180 (4.57)     | 0.150 (3.81)     | 7            |

\* These part nos. are supplied with the dispense valve.

## Needle Adapter 109599

Required to mount the following needle nozzles to the dispense valve.

## Dispense Needle Nozzles

Require 109599 Needle Adapter (see above) to mount to the dispense valve. 2.0 in. (50.8 mm) long. Chrome plated brass; stainless steel wetted parts.

| Part No. | O.D. inches (mm) | I.D. inches (mm) | Needle Gauge |
|----------|------------------|------------------|--------------|
| 112008   | .016 (0.41)      | .008 (0.20)      | 27           |
| 112009   | .018 (0.46)      | .010 (0.25)      | 26           |
| 112010   | .022 (0.56)      | .012 (0.30)      | 24           |
| 112011   | .025 (0.64)      | .013 (0.33)      | 23           |
| 112012   | .028 (0.71)      | .016 (0.41)      | 22           |
| 112013   | .032 (0.81)      | .020 (0.51)      | 21           |
| 112014   | .036 (0.91)      | .023 (0.58)      | 20           |
| 112015   | .043 (1.09)      | .027 (0.69)      | 19           |
| 112016   | .050 (1.27)      | .033 (0.84)      | 18           |
| 112017   | .059 (1.50)      | .041 (1.04)      | 17           |
| 112018   | .065 (1.65)      | .047 (1.19)      | 16           |
| 112019   | .072 (1.83)      | .054 (1.37)      | 15           |
| 112020   | .083 (2.11)      | .063 (1.60)      | 14           |
| 112021   | .095 (2.41)      | .071 (1.80)      | 13           |
| 112022   | 0.109 (2.77)     | .085 (2.16)      | 12           |
| 112023   | 0.120 (3.05)     | .094 (2.39)      | 11           |
| 112024   | 0.134 (3.40)     | 0.106 (2.69)     | 10           |
| 112025   | 0.165 (4.19)     | 0.135 (3.43)     | 8            |

## Dispense Needle Nozzles, with Plastic Hub

Require 109599 Needle Adapter (see above) to mount to the dispense valve. 0.5 in. (13 mm) long. Stainless steel wetted parts.

| Part No. | O.D. inches (mm) | I.D. inches (mm) | Needle Gauge |
|----------|------------------|------------------|--------------|
| 690340   | .012 (0.30)      | .006 (0.15)      | 30           |
| 690349   | .018 (0.46)      | .009 (0.23)      | 26           |
| 690348   | .020 (0.51)      | .010 (0.25)      | 25           |
| 690058   | .025 (0.64)      | .013 (0.33)      | 23           |
| 690339   | .028 (0.71)      | .016 (0.41)      | 22           |
| 690336   | .032 (0.81)      | .020 (0.51)      | 21           |
| 690335   | .036 (0.91)      | .023 (0.58)      | 20           |
| 690334   | .043 (1.09)      | .027 (0.69)      | 19           |
| 690333   | .050 (1.27)      | .033 (0.84)      | 18           |

|        |             |             |    |
|--------|-------------|-------------|----|
| 690332 | .072 (1.83) | .054 (1.37) | 15 |
| 690331 | .083 (2.11) | .063 (1.60) | 14 |

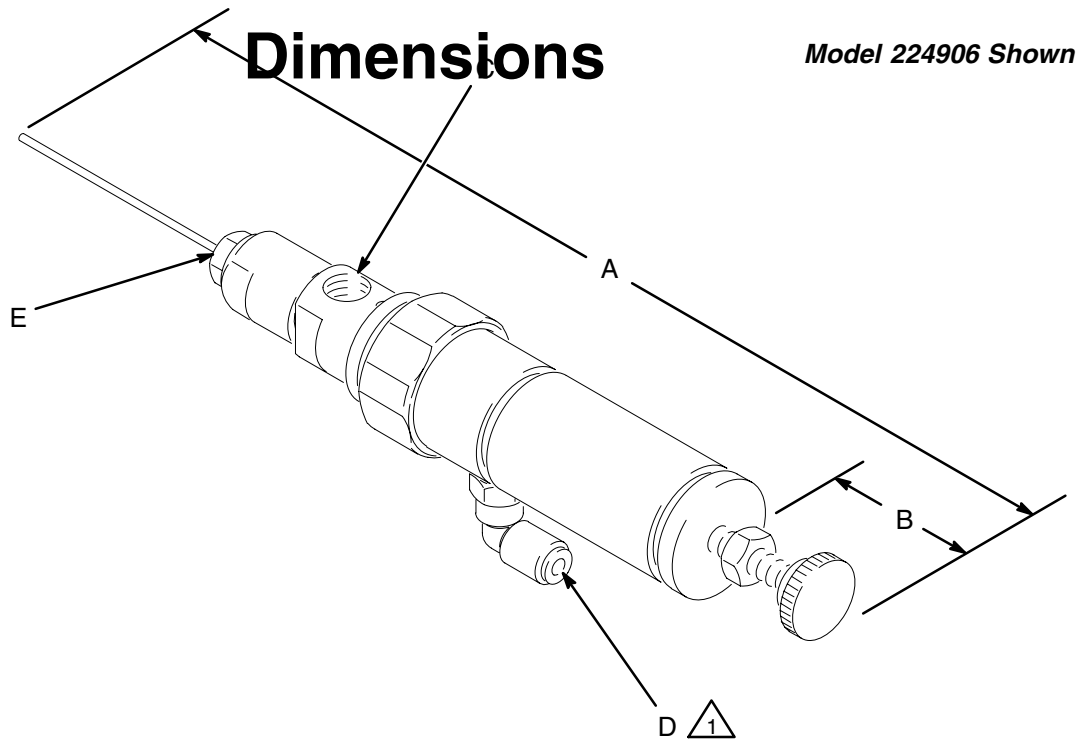

Model 224906 Shown

 Remove tube fitting (D) to access 1/8 npt(f) alternate air inlet.

01795

| Model No. | A<br>(Maximum)        | B<br>(Maximum)      | Weight               |
|-----------|-----------------------|---------------------|----------------------|
| 224906    | 9.5 in.<br>(241.3 mm) | 0.75 in.<br>(19 mm) | 0.85 lb<br>(0.4 kg)  |
| 235877    | 9.5 in.<br>(241.3 mm) | 0.75 in.<br>(19 mm) | 1.125 lb<br>(0.5 kg) |

**Port Sizes (All Models)**

- C 1/8 npt(f) Fluid Inlet
- D Fitting for 0.157 in. (4 mm) Air Inlet Tube
- E 1/8 npt(f) Fluid Outlet

## Technical Data

Maximum fluid inlet pressure ..... 900 psi (63 bar)  
 Maximum air inlet pressure ..... 100 psi (7 bar)  
 Maximum operating temperature ..... 110°F (43°C)  
 Wetted parts ..... Graphite-Filled PTFE, Acetal,  
 302 and 17-4 Passivated Stainless Steel;  
*Needle Nozzles:* Chrome-Plated Brass and  
 303 Stainless Steel

# Graco Standard Warranty

Graco warrants all equipment manufactured by Graco and bearing its name to be free from defects in material and workmanship on the date of sale to the original purchaser for use. With the exception of any special, extended, or limited warranty published by Graco, Graco will, for a period of twelve months from the date of sale, repair or replace any part of the equipment determined by Graco to be defective. This warranty applies only when the equipment is installed, operated and maintained in accordance with Graco's written recommendations.

This warranty does not cover, and Graco shall not be liable for general wear and tear, or any malfunction, damage or wear caused by faulty installation, misapplication, abrasion, corrosion, inadequate or improper maintenance, negligence, accident, tampering, or substitution of non-Graco component parts. Nor shall Graco be liable for malfunction, damage or wear caused by the incompatibility of Graco equipment with structures, accessories, equipment or materials not supplied by Graco, or the improper design, manufacture, installation, operation or maintenance of structures, accessories, equipment or materials not supplied by Graco.

This warranty is conditioned upon the prepaid return of the equipment claimed to be defective to an authorized Graco distributor for verification of the claimed defect. If the claimed defect is verified, Graco will repair or replace free of charge any defective parts. The equipment will be returned to the original purchaser transportation prepaid. If inspection of the equipment does not disclose any defect in material or workmanship, repairs will be made at a reasonable charge, which charges may include the costs of parts, labor, and transportation.

**THIS WARRANTY IS EXCLUSIVE, AND IS IN LIEU OF ANY OTHER WARRANTIES, EXPRESS OR IMPLIED, INCLUDING BUT NOT LIMITED TO WARRANTY OF MERCHANTABILITY OR WARRANTY OF FITNESS FOR A PARTICULAR PURPOSE.**

Graco's sole obligation and buyer's sole remedy for any breach of warranty shall be as set forth above. The buyer agrees that no other remedy (including, but not limited to, incidental or consequential damages for lost profits, lost sales, injury to person or property, or any other incidental or consequential loss) shall be available. Any action for breach of warranty must be brought within two (2) years of the date of sale.

Graco makes no warranty, and disclaims all implied warranties of merchantability and fitness for a particular purpose in connection with accessories, equipment, materials or components sold but not manufactured by Graco. These items sold, but not manufactured by Graco (such as electric motors, switches, hose, etc.), are subject to the warranty, if any, of their manufacturer. Graco will provide purchaser with reasonable assistance in making any claim for breach of these warranties.

In no event will Graco be liable for indirect, incidental, special or consequential damages resulting from Graco supplying equipment hereunder, or the furnishing, performance, or use of any products or other goods sold hereto, whether due to a breach of contract, breach of warranty, the negligence of Graco, or otherwise.

## **FOR GRACO CANADA CUSTOMERS**

The parties acknowledge that they have required that the present document, as well as all documents, notices and legal proceedings entered into, given or instituted pursuant hereto or relating directly or indirectly hereto, be drawn up in English. Les parties reconnaissent avoir convenu que la rédaction du présente document sera en Anglais, ainsi que tous documents, avis et procédures judiciaires exécutés, donnés ou intentés à la suite de ou en rapport, directement ou indirectement, avec les procédures concernées.

# Graco Information

**TO PLACE AN ORDER**, contact your Graco distributor, or call one of the following numbers to identify the distributor closest to you:

**1-800-328-0211 Toll Free**

**612-623-6921**

**612-378-3505 Fax**

*All written and visual data contained in this document reflects the latest product information available at the time of publication.*

*Graco reserves the right to make changes at any time without notice.*

MM 308266

**Sales Office:** Minneapolis  
**International Offices:** Belgium, Korea, Hong Kong, Japan

**www.graco.com**

PRINTED IN USA 308266 07/1993, Revised 1/2006