



INSTRUCTIONS

This manual contains important warnings and information.  
**READ AND KEEP FOR REFERENCE.**

*First choice when quality counts.™*

120 VAC, 18A

## Mark V Texture Sprayer

*3000 psi (21.0 MPa, 210 bar) Maximum Working Pressure*

### Model 231-406, Series A

Includes texture sprayer, 50 foot hose, 3 foot hose, and texture spray gun

Patents Pending

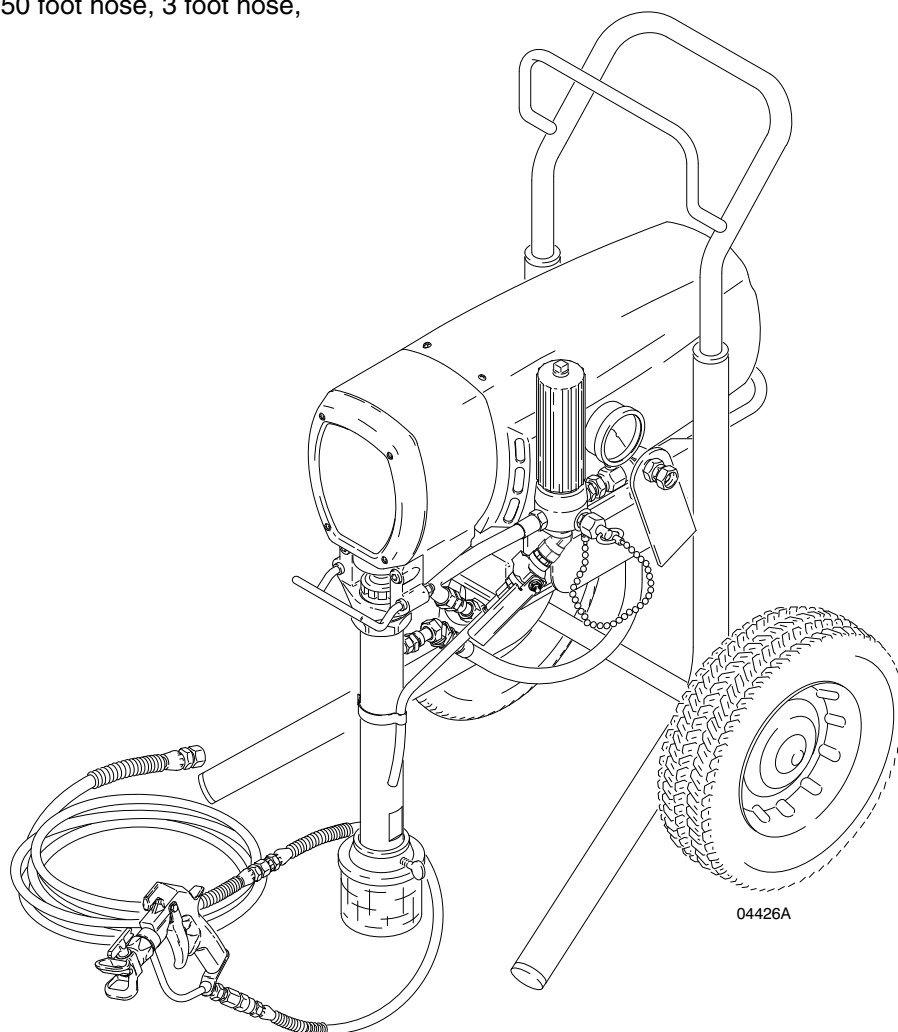

# Table of Contents

Warnings .....	2	Pressure Control Repair .....	20
Major Components .....	5	Bearing Housing & Connecting Rod .....	23
Setup .....	6	Drive Housing .....	24
Airless Operation .....	7	Sprayer Parts Drawing .....	26
Operation .....	8	Sprayer Parts List .....	27
Flushing .....	10	Accessories .....	30
Troubleshooting .....	12	Technical Data .....	30
Motor Brush Replacement .....	14	Dimensions .....	30
Displacement Pump .....	16	Graco Warranty .....	32
Motor .....	17	Graco Phone Number .....	32
Pressure Control .....	19		

## Symbols

### Warning Symbol



This symbol alerts you to the possibility of serious injury or death if you do not follow the instructions.

### Caution Symbol



This symbol alerts you to the possibility of damage to or destruction of equipment if you do not follow the instructions.

## ! WARNING



### FIRE AND EXPLOSION HAZARD

Improper grounding, poor ventilation, open flames or sparks can cause a hazardous condition and result in a fire or explosion and serious injury.



- If there is any static sparking or you feel an electric shock while using this equipment, **stop spraying immediately**. Do not use the equipment until you identify and correct the problem.
- Provide fresh air ventilation to avoid the buildup of flammable fumes from solvents or the fluid being sprayed.
- Keep the spray area free of debris, including solvent, rags, and gasoline.
- Electrically disconnect all equipment in the spray area.
- Extinguish all open flames or pilot lights in the spray area.
- Do not smoke in the spray area.
- Do not turn on or off any light switch in the spray area while operating or if fumes are present.
- Do not operate a gasoline engine in the spray area.

# ⚠ WARNING

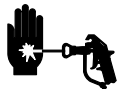

## INJECTION HAZARD

Spray from the gun, leaks or ruptured components can inject fluid into your body and cause extremely serious injury, including the need for amputation. Fluid splashed in the eyes or on the skin can also cause serious injury.

- Fluid injected into the skin is a serious injury. The injury may look like just a cut, but it is a serious injury. Get immediate medical attention.
- Do not point the gun at anyone or at any part of the body.
- Do not put your hand or fingers over the spray tip.
- Do not stop or deflect leaks with your hand, body, glove or rag.
- Do not “blow back” fluid; this is not an air spray system.
- Always have the tip guard and the trigger guard on the gun when spraying.
- Check the gun diffuser operation weekly. Refer to the gun manual.
- Be sure the gun trigger safety operates before spraying.
- Lock the gun trigger safety when you stop spraying.
- Follow the **Pressure Relief Procedure** on page 8 if the spray tip clogs and before cleaning, checking or servicing the equipment.
- Tighten all fluid connections before operating the equipment.
- Check the hoses, tubes, and couplings daily. Replace worn or damaged parts immediately. Do not repair high pressure couplings; you must replace the entire hose.
- Fluid hoses must have spring guards on both ends, to help protect them from rupture caused by kinks or bends near the couplings.



## TOXIC FLUID HAZARD

Hazardous fluid or toxic fumes can cause serious injury or death if splashed in the eyes or on the skin, inhaled, or swallowed.

- Know the specific hazards of the fluid you are using.
- Store hazardous fluid in an approved container. Dispose of hazardous fluid according to all local, state and national guidelines.
- Always wear protective eyewear, gloves, clothing and respirator as recommended by the fluid and solvent manufacturer.



## MOVING PARTS HAZARD

Moving parts can pinch or amputate your fingers.

- Keep clear of all moving parts when starting or operating the pump.
- Before servicing the equipment, follow the **Pressure Relief Procedure** on page 8 to prevent the equipment from starting unexpectedly.

# ! WARNING



INSTRUCTIONS

## EQUIPMENT MISUSE HAZARD

Equipment misuse can cause the equipment to rupture or malfunction and result in serious injury.

- This equipment is for professional use only.
- Read all instruction manuals, tags, and labels before operating the equipment.
- Use the equipment only for its intended purpose. If you are uncertain about usage, call your Graco distributor.
- Do not alter or modify this equipment. Use only genuine Graco parts and accessories.
- Check equipment daily. Repair or replace worn or damaged parts immediately.
- Do not exceed the maximum working pressure of the lowest rated system component. Refer to the **Technical Data** on page 30 for the maximum working pressure of this equipment.
- Use fluids and solvents which are compatible with the equipment wetted parts. Refer to the **Technical Data** section of all equipment manuals. Read the fluid and solvent manufacturer's warnings.
- Do not use 1,1,1-trichloroethane, methylene chloride, other halogenated hydrocarbon solvents or fluids containing such solvents in pressurized aluminum equipment. Such use could result in a chemical reaction, with the possibility of explosion.
- Do not use hoses to pull equipment.
- Route hoses away from traffic areas, sharp edges, moving parts, and hot surfaces. Do not expose Graco hoses to temperatures above 180°F (82°C) or below -40°F (-40°C).
- Do not lift pressurized equipment.
- Comply with all applicable local, state, and national fire, electrical, and safety regulations.

**NOTE:** This is an example of the DANGER label on your sprayer. This label is available in other languages, free of charge. See page 30 to order.

! DANGER !	
! FIRE AND EXPLOSION HAZARD !	! SKIN INJECTION HAZARD !
<p>Spray painting, flushing or cleaning equipment with flammable liquids in confined areas can result in fire or explosion.</p> <p>Use outdoors or in extremely well ventilated areas. Ground equipment, hoses, containers and objects being sprayed.</p> <p>Avoid all ignition sources such as static electricity from plastic drop cloths, open flames such as pilot lights, hot objects such as cigarettes, arcs from connecting or disconnecting power cords or turning light switches on and off.</p> <p>Failure to follow this warning can result in death or serious injury.</p>	<p>Liquids can be injected into the body by high pressure airless spray or leaks – especially hose leaks.</p> <p>Keep body clear of the nozzle. Never stop leaks with any part of the body. Drain all pressure before removing parts. Avoid accidental triggering of gun by always setting safety latch when not spraying.</p> <p>Never spray without a tip guard.</p> <p>In case of accidental skin injection, seek immediate "Surgical Treatment".</p> <p>Failure to follow this warning can result in amputation or serious injury.</p>
<p>READ AND UNDERSTAND ALL LABELS AND INSTRUCTION MANUALS BEFORE USE</p>	

# Major Components

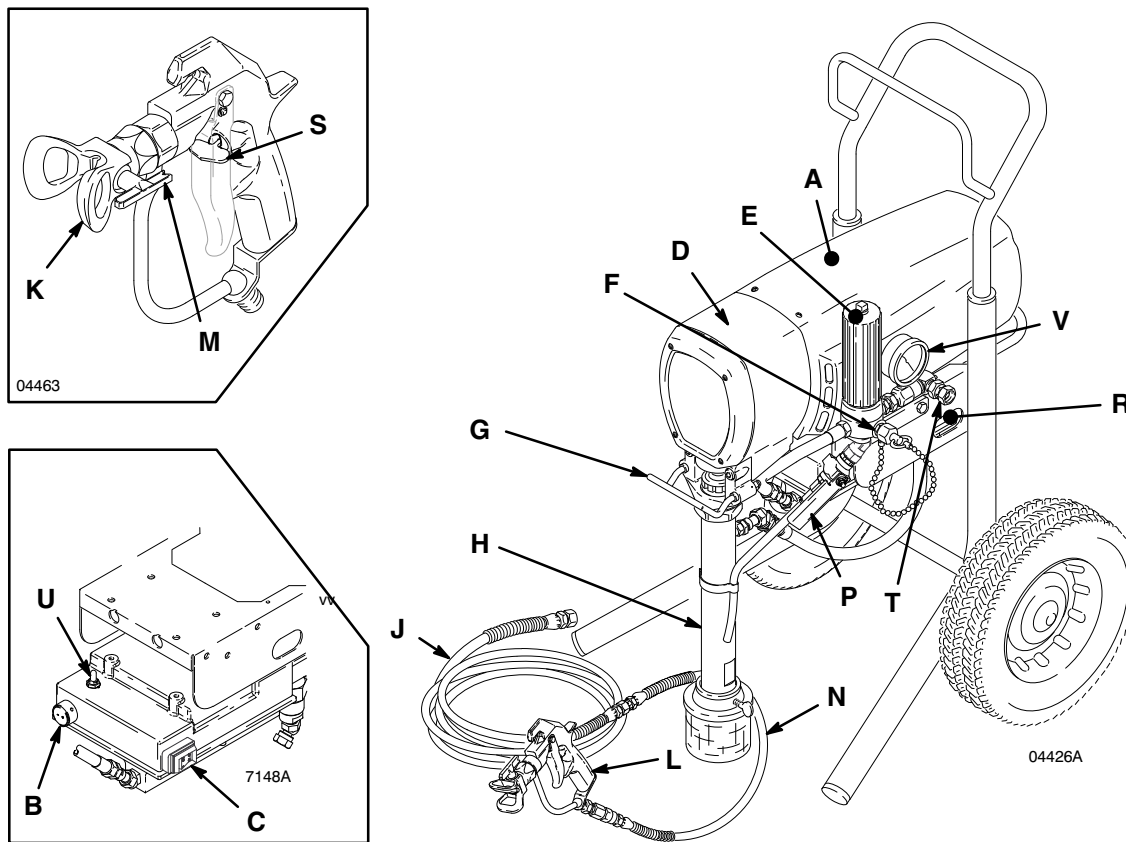

Fig. 1

<b>A</b>	Motor (Under shield shown)	DC motor, 120 Vac, 60 Hz, 18A, 1 phase
<b>B</b>	Pressure Adjusting Knob	Controls fluid outlet pressure
<b>C</b>	ON/OFF Switch	Power switch that controls 120 Vac power to sprayer
<b>D</b>	Drive Assembly	Transfers power from DC motor to the displacement pump
<b>E</b>	Fluid Filter	Filter of fluid between source and spray gun
<b>F</b>	Secondary Fluid Outlet	Second hose and spray gun is connected here
<b>G</b>	Pail Hanger	Container of fluid to be sprayed may be hung here
<b>H</b>	Displacement Pump	Pressures fluid to be sprayed through spray gun
<b>J</b>	50 ft (15 m) Main Hose	3/8 in. ID, grounded, nylon hose with spring guards on both ends
<b>K</b>	RAC IV Tip Guard	Reverse-A-Clean (RAC) tip guard reduces the risk of fluid injection injury
<b>L</b>	Texture Spray Gun	3000 psi (21.0 MPa, 210 bar) texture spray gun with gun safety latch
<b>M</b>	RAC IV Switch Tip	RAC switch tip atomizes fluid and removes clogs from spray tip without removing tip from spray gun
<b>N</b>	3 ft (0.9 m) Hose	1/4 in. ID, grounded, nylon hose used between 50 ft hose and spray gun to allow more flexibility when spraying
<b>P</b>	Pressure Drain Valve	Relieves fluid pressure when open
<b>R</b>	Pressure Control	Controls motor speed to maintain fluid pressure. Works with pressure adjusting knob.
<b>S</b>	Spray Gun Safety Latch	Inhibits accidental triggering of spray gun
<b>T</b>	Primary Fluid Outlet	Hose and spray gun is connected here
<b>U</b>	15/20 Amp Switch	Allows sprayer to operate on 15A service with reduced performance
<b>V</b>	Gauge	System pressure indicator, 3000 psi (21.0 MPa, 210 bar)

# Setup

## ⚠ WARNING



### FIRE AND EXPLOSION HAZARD

Proper electrical grounding is essential to reduce the risk of fire or explosion which can result in serious injury and property damage. Also read **FIRE OR EXPLOSION HAZARD** on page 2.

## ⚠ WARNING

If you supply your own hoses and spray gun, be sure the hoses are electrically conductive, that the gun has a tip guard, and that each part is rated for at least *3000 psi (21.0 MPa, 210 bar) Working Pressure*. This is to reduce the risk of serious injury caused by static sparking, fluid injection or over-pressurization and rupture of the hose or gun.

## ⚠ CAUTION

To avoid damaging the pressure control, which may result in poor equipment performance and component damage, follow these precautions:

1. Always use a nylon spray hose at least 50 ft (15 m) long.
2. Never use a wire braid hose as it is too rigid to act as a pulsation dampener.
3. Never install any shutoff device between the filter and the hose. See A, Fig. 2.

1. Connect gun (B) and 50 ft hose (C). Don't install the spray tip yet. See Fig. 2.
2. Fill wet-cup (D) 1/3 full with Graco Throat Seal Liquid, supplied.

3. Check electrical service. Be sure electrical service is 120 Vac, 60 Hz, 20 A. Use properly grounded outlet. Do not remove grounding prong of power supply cord or of any extension cords used. Do not use an adapter. Extension cords must have 3 wires of minimum 12 gauge size. Long extension cords reduce sprayer performance. If 20 amp service is not available, set 15/20 amp switch (C) to 15 amp to avoid nuisance tripping of circuit breakers.
4. With switch (E) to OFF, plug power supply cord into grounded electrical outlet located at least 20 ft away from spray area.
5. Flush pump before using it. See page 10.

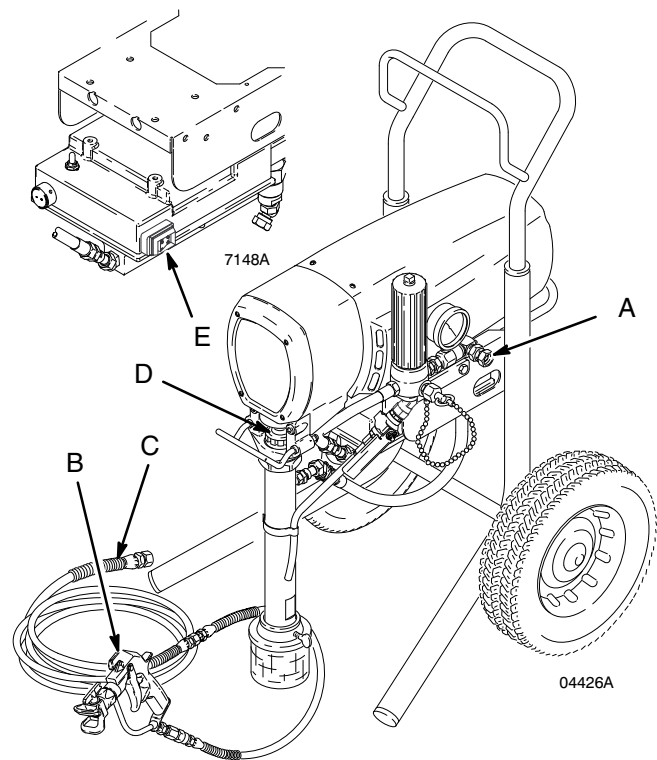

Fig 2

# Airless Operation

## ⚠ WARNING



### INJECTION HAZARD

To reduce the risk of serious injury, whenever you are instructed to relieve pressure, follow the **Pressure Relief Procedure** on page 8.

## Startup

Always use this procedure to help ensure the sprayer is ready to operate and that you start it safely. See Fig. 3

1. For first time startup, flush sprayer. See page 10.
2. Close pressure drain valve (A).
3. Don't install spray tip until pump is primed!
4. Put pump (B) into supply pail.
5. Turn pressure adjusting knob (C) counterclockwise to lowest setting.
6. Disengage gun safety latch.

## ⚠ WARNING

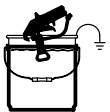

### FIRE AND EXPLOSION HAZARD

To reduce static sparking and splashing, always remove the spray tip from the gun, and hold a metal part of the gun firmly to the side of a grounded metal pail when flushing.

7. To prime pump, squeeze gun trigger and hold it open, turn ON/OFF switch (D) to ON, and slowly increase pressure setting (C) until sprayer starts. Keep gun triggered until all air is forced out of system and material flows freely from gun. Release gun trigger and engage gun safety latch.

## ⚠ CAUTION

Do not run the sprayer dry for more than 30 seconds to avoid damaging the pump packings.

8. Check all fluid connections for leaks. If any leaks are found, relieve pressure before tightening connections.

## ⚠ WARNING



### FIRE AND EXPLOSION HAZARD

To reduce the risk of fluids entering control box, check weep hole (Fig.16, C) regularly. Replace o-ring when any leakage is seen. Also read **FIRE OR EXPLOSION HAZARD** on page 2.

9. Check weep hole (Fig. 16, B) of pressure control for leakage at start up and during operation. If leakage, replace o-ring as instructed in Pressure Control Transducer and O-Ring Replacement on page 20.
10. Engage gun safety latch. Install spray tip and tip guard (E) according to instructions supplied with tip guard.
11. Adjust pressure.
  - a. Turn pressure adjusting knob (C) clockwise until spray from gun is just completely atomized. To reduce overspray, fogging, and tip wear and to extend life of sprayer, use lowest possible pressure needed to get good atomization.
  - a. If more coverage is needed, use larger tip rather than increasing pressure.
  - a. Test spray pattern. To adjust direction of spray pattern, engage gun safety latch, loosen retaining nut, position tip guard horizontally for horizontal pattern or vertically for vertical pattern and tighten retaining nut.

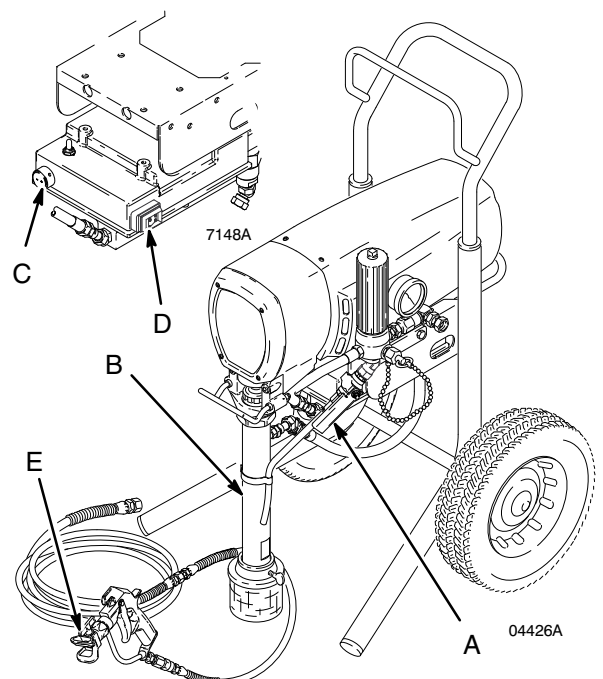

Fig 3

# Operation

## Pressure Relief Procedure

### **WARNING**



#### **PRESSURIZED EQUIPMENT HAZARD**

The system pressure must be manually relieved to prevent the system from starting or spraying accidentally. To reduce the risk of an injury from accidental spray from the gun, splashing fluid, or moving parts, follow the **Pressure Relief Procedure** whenever you:

- are instructed to relieve the pressure,
- stop spraying,
- check or service any of the system equipment,
- or install or clean the spray nozzle.

1. Engage gun safety latch.
2. Turn ON/OFF switch to OFF.
3. Unplug power cord.
4. Disengage gun safety latch. Hold metal part of gun against grounded metal pail and trigger gun into pail to relieve pressure.
5. Engage gun safety latch.
6. Open any fluid drain valves in system. Leave drain valve open until ready to dispense again.

## Cleaning a Clogged Tip

### **WARNING**





#### **INJECTION HAZARD**

To reduce the risk of serious injury, whenever you are instructed to relieve pressure, follow the **Pressure Relief Procedure**.

#### **Procedure.**

1. If spray tip clogs, release gun trigger, engage gun safety latch (B), and rotate RAC IV handle (A) 180°. See Fig 4.
2. Disengage gun safety latch (C) and trigger gun into waste container. Engage gun safety latch again.
3. Return tip handle to original position, disengage gun safety latch, and resume spraying.
4. If tip is still clogged, engage gun safety latch, shut off and unplug sprayer, and open pressure drain valve to relieve pressure. Remove tip and soak it in solvent. Do not scrape or chip off debris which could damage tip.

 1 The tip handle (A) is shown in spraying position. Rotate the tip handle 180° in direction of the arrow for clearing a clog.

 2 Engaged.

 3 Disengaged.

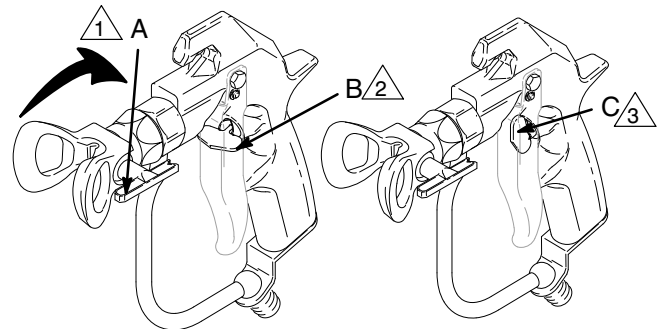

**Fig 4**

03966



# Operation

## Shutdown and Care

1. Check wet-cup (A) daily. See Fig 5. First relieve pressure and remove wet-cup plug. Keep wet-cup 1/3 full with Graco Throat Seal Liquid at all times to help prevent material from building up on piston rod which causes packings to wear prematurely. Tighten wet-cup, which is also packing nut, just enough to stop leakage. Overtightening wet-cup may cause packings to bind and wear out quickly. Use screwdriver and light hammer to adjust wet-cup.
2. Clean fluid filter (B) often and whenever sprayer is stored. First relieve pressure. See manual 307–273 for cleaning procedure.
3. Fill connecting rod cavity (C) with motor oil every 100 hours of operation. First relieve pressure and then remove front cover.
4. For short shutoff periods, leave pump in the material, relieve pressure, and clean spray tip.

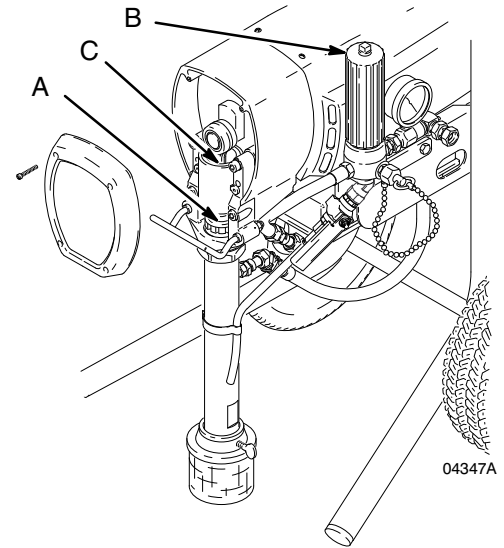

**Fig 5**

5. Before storing sprayer, flush thoroughly, leaving a coating of mineral spirits, then relieve pressure.
6. Coil hose and hang on cart handle for protection.

# Flushing

<sup>1</sup>Use this category for flushing a brand new sprayer and flushing after storage.

System has this fluid in it:	Next fluid to be sprayed:	Flushing order:			Before you spray:
		Flush 1	Flush 2	Flush 3	
<sup>1</sup> Oil-based solvent or fluid	Oil-based fluid – new color	Mineral spirits	none	none	Prime with oil-based fluid
Oil-based solvent or fluid	Water-based fluid	Mineral spirits	Warm soapy water	Clean water	Prime with water-based fluid
Water or water-based fluid	Water-based fluid – new color	Warm soapy water	Clean water	none	Prime with water
Water or water-based fluid	Oil-based fluid	Warm soapy water	Clean water	Mineral spirits	Prime with oil

The following sections are for preparing a sprayer for storage.

Oil-based solvent or fluid	Prepare for storage	Mineral spirits	none	none	Relieve pressure, Leave drain valve open
Water or water-based fluid	Prepare for storage	Warm soapy water	Clean water	Mineral spirits	Relieve pressure, Leave drain valve open

## CAUTION

Never allow water to freeze in the pressure control. Doing so prevents the sprayer from being started and causes serious damage to the pressure control. Push the water out with mineral spirits.

1. Relieve pressure.
2. Remove filter bowl (A) and screen (B). Install bowl (A) and filter support (C) without screen (B). See Fig 6.
3. Close pressure drain valve (D).

4. Pour 2 quarts of compatible solvent into grounded metal pail. Put pump in pail.
5. Remove spray tip from gun.
6. Turn pressure adjusting knob (E) counterclockwise to lowest pressure setting.

## WARNING



### FIRE AND EXPLOSION HAZARD

To reduce static sparking and splashing, always remove the spray tip from the gun, and hold a metal part of the gun firmly to the side of a grounded metal pail when flushing.

# Flushing

7. Hold a metal part of gun firmly against metal waste container. See preceding WARNING! Trigger gun, turn sprayer switch (F) on, and slowly increase pressure until sprayer just starts. Keep gun triggered until all air is forced out of system and solvent flows freely from the. Release trigger and engage gun safety latch.

**NOTE:** If the pump is hard to prime, open the drain valve. When fluid comes from the valve, close it. Proceed as in Step 7.

## CAUTION

Do not run the sprayer dry for more than 30 seconds to avoid damaging the pump packings.

8. Remove pump from pail. Disengage gun safety latch and trigger gun to force solvent from hose. Do not run pump dry for more than 30 seconds to avoid damaging pump packings! Shut off sprayer.
9. Leave pressure drain valve (D) open until ready to use sprayer again.
10. Clean filter screen (B) and reinstall it. Reinstall bowl (A), hand tighten only.
11. If you flushed with mineral spirits and are going to use a water-base material, flush with soapy water and then clean water. Relieve pressure.

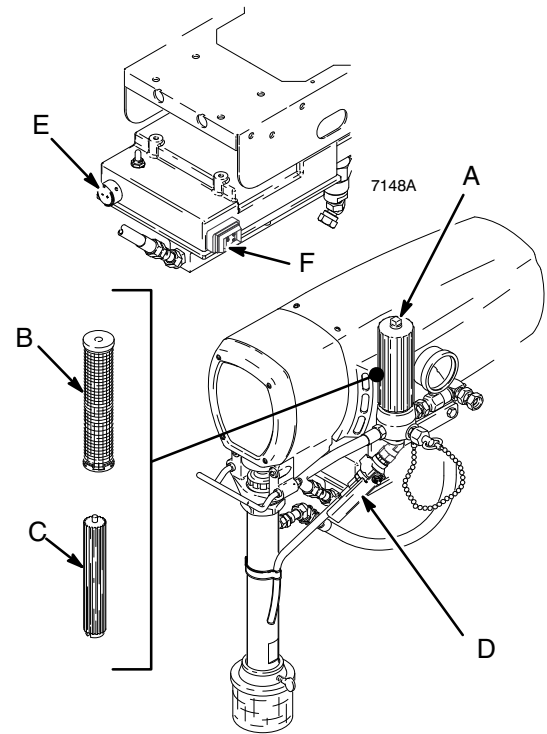

Fig 6

7147A

# Troubleshooting

## WARNING



### INJECTION HAZARD

To reduce the risk of serious injury, whenever you are instructed to relieve pressure, follow the **Pressure Relief Procedure** on page 8.

Check everything in the guide before disassembling the sprayer.

TYPE OF PROBLEM	WHAT TO CHECK If check is OK, go to next check	WHAT TO DO When check is not OK refer to this column
Building circuit breaker opens	Check all electrical wiring for damaged insulation.	Replace any damaged wiring.
	Check for other electrical appliances on circuit.	Shutdown other electrical appliances on circuit.
	Check position of 15–20 (Lo–High) amp switch.	Put switch in 15 (LO) position.
Sprayer will not run	Check pressure control knob setting. Motor will not run if it is at minimum setting (fully counterclockwise).	Slowly increase pressure setting to see if motor starts.
	Check for a clogged spray tip. Refer to separate gun or tip instruction manual.	Relieve pressure. Refer to separate gun or tip instruction manual for tip cleaning.
	Check extension cord for visible damage. Use a volt meter or test lamp at extension cord outlet to check.	Replace extension cord.
	Check sprayer power supply cord for visible damage such as broken insulation or wires.	Replace power supply cord.
	Check electrical supply with volt meter. Meter should read 105–125 VAC.	Reset building circuit breaker; replace building fuse. Try another outlet.
	Check for motor damage. Remove drive housing assembly. See motor test on page 19. Try to rotate fan by hand.	Replace motor (1) if fan won't turn.
	Check for locked motor rotor. Unplug cord and try to turn fan blades with a screwdriver.	Repair gear train or pump, if damaged. Thaw the sprayer, if frozen; See the NOTE on page 13. Replace the pressure control, if damaged.
	Check for shorted motor. Use ohmmeter to check for shorts between motor leads or between motor leads and motor frame.	Inspect for damage to motor brush leads. Replace motor, if necessary.
Defective pressure control transducer.	Replace pressure control transducer. See page 20.	
Poor spray pattern	Check for worn spray tip.	Relieve pressure and then replace the tip. See the separate gun or tip manual.

**NOTE:** Troubleshooting is continued on the next page.

# Troubleshooting

TYPE OF PROBLEM	WHAT TO CHECK If check is OK, go to next check	WHAT TO DO When check is not OK refer to this column
(Continued) Motor runs and pump strokes, but output is low or there is no output.	Check for worn spray tip.	Follow <b>Pressure Relief Procedure Warning</b> , then replace tip. See your separate gun or tip manual.
	Check motor brushes; check for loose leads and terminals, minimum 10 mm brush length, broken or misaligned springs, or brushes binding in holders. See page 14.	Replace parts as needed. See page 14.
	Check motor armature for shorts by using an armature tester (growler).	Replace motor. See page 17 .
	Check to see if pump continues to stroke when gun trigger is released. With pump on and primed, trigger gun momentarily, then release and engage safety latch. Relieve pressure, turn off and unplug sprayer.	Repair pump. See manual 307–806 for repair.
	Check to see if intake valve ball and piston ball are seating properly.	Repair pump. See manual 307–806 for repair.
	Check for leaking around throat packing nut which may indicated worn or damaged packings.	Tighten the packing nut/wetcup. Repair pump. See manual 307–806 for repair.
	Defective pressure control transducer.	Replace pressure control transducer. See page 20.
Motor runs but pump does not stroke.	Check displacement pump connecting rod pin (20). See page 16.	Replace pin, if missing. Be sure retainer spring (35) is fully in groove all around connecting rod. See page 16.
	Check for frozen or hardened material in the pump (39).	Thaw. See the NOTE below. Plug in sprayer and turn on. Slowly increase pressure setting to see if motor starts.
	Be sure crank in drive housing rotates; plug in sprayer and turn on briefly to check. Turn off and unplug sprayer.	Check drive housing assembly for damage and replace if necessary. See page 24.
Motor is hot and runs intermittently.	Determine if sprayer was operated at high pressure with small tips, which causes low motor RPM and excessive heat build up.	Decrease pressure setting or increase tip size.
	Be sure ambient temperature where sprayer is located is no more than 90°F and sprayer is not located in direct sun.	Move sprayer to shaded, cooler area, if possible.
	Determine in sprayer was turned on, pressurized, but not operating for long periods of time.	Turn off sprayer whenever you stop spraying for a while and relieve fluid pressure.

**NOTE:** Thaw the sprayer if water or water-based material has frozen in it, by placing it in a warm area. Do not try to start the sprayer until it has thawed completely. If material hardened (dried) in the sprayer, replace the pump packings. See pump manual 307–806.

# Motor Brush Replacement

## ⚠ WARNING



### ELECTRIC SHOCK HAZARD

To reduce the risk of Electric Shock: wait 5 minutes after turning sprayer off before servicing to allow stored current to discharge.

charge.

**NOTE:** Replace brushes when they have worn to less than 0.4 in. Check both brushes. Brush Repair Kit 220–853 is available. A new spring clip, 110–816, may be purchased separately.

**NOTE:** Replacement brushes may last only half as long as the original ones. To maximize brush life, break in new brushes by operating the sprayer for at least one hour with no load (remove the pump connecting rod pin).

## ⚠ WARNING



### INJECTION HAZARD

To reduce the risk of serious injury, whenever you are instructed to relieve pressure, follow the **Pressure Relief Procedure** on page 8.

Procedure on page 8.

1. Relieve pressure.
2. Remove motor cover (14) and both brush inspection covers (A). See Fig 7.
3. Push in spring clip (D) to unhook, and then pull out. See Fig 8.
4. Loosen terminal screw (F). Pull brush lead (E) away, leaving motor lead (G) in place. Remove brush (C) and spring (B). See Fig 9.

5. Inspect motor commutator for excessive pitting, burning or gouging. A black color on commutator is normal. Have commutator resurfaced by qualified motor repair shop if brushes seem to wear too fast.
6. Install new brush (C) so lead is in long slot (J) of the brush holder (H). Slide brush lead (E) terminal under terminal screw (F) washer. Make sure motor lead (G) is still connected at screw. Tighten screw (F). See Fig 10.
7. Place spring (B) on brush (C). See Fig 10.
8. Push in spring clip (D) and hook. See Fig 10.
9. Repeat for other side.

## ⚠ CAUTION

Do not run the sprayer dry for more than 30 seconds to avoid damaging the pump packings.

10. Reinstall remaining parts.

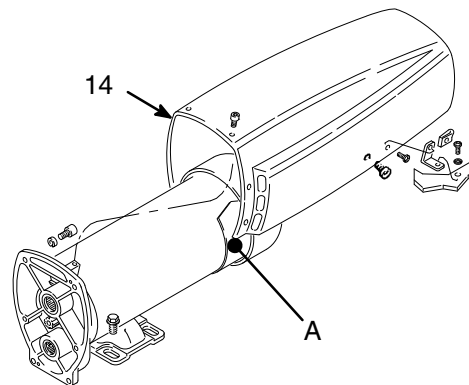

Fig 7

01891

# Motor Brush Replacement

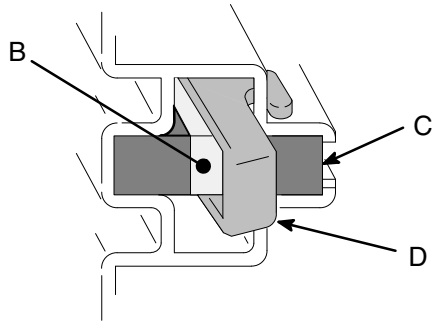

Fig 8

01227

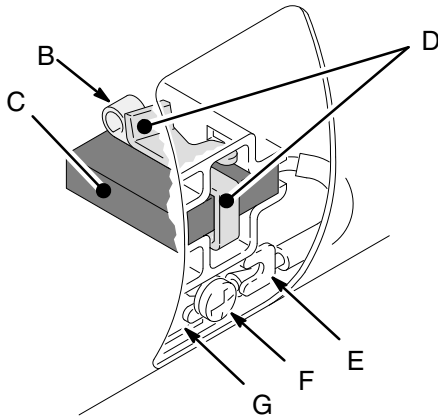

Fig 9

01227

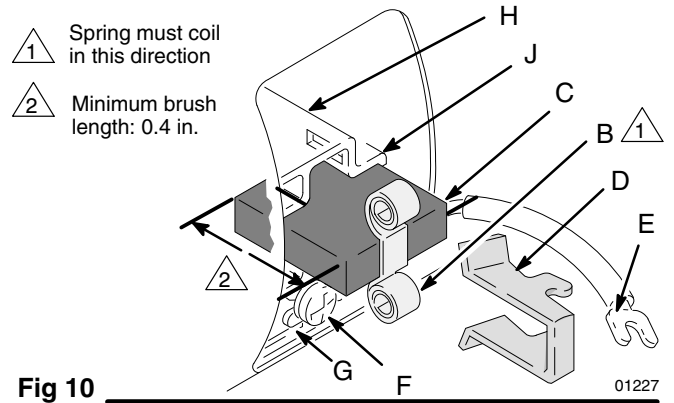

Fig 10

01227

# Displacement Pump

**Removing the pump** See Fig 11 and parts list.

1. Flush pump, if possible, and relieve pressure again. Stop pump with piston rod in its lowest position, if possible.
2. Remove hose (132).
3. Push retaining spring (35) up and push out pin (20).
4. Loosen locknut (38) and unscrew pump one half turn from bearing housing (27).
5. Remove spring clip (75) and drain tube (79) from pump.
6. Remove pump.

## Repairing the pump

1. See manual 307–806 for parts and repair.

**Installing the pump** See Figs. 11, 12, and parts list.

1. Screw displacement pump into bearing housing (27) until pin hole in connecting rod assembly (29) and displacement rod (A) align. Install pin (20).
2. Continue to screw pump into bearing housing until top threads of pump cylinder are flush with face of bearing housing, and outlet nipple (75) is straight back. Unscrew pump 1/2 turn so pump outlet is at rear. Push retaining spring (35) into groove around connecting rod to prevent it from vibrating loose. Tighten locknut (38) to 70 ft-lb (95 N.m).

3. Install spring clip (75) and drain tube (79) to pump.
4. Tighten packing nut/wet-cup just enough to stop leakage, but no tighter. Fill wet-cup/packing nut 1/3 full with Graco TSL.

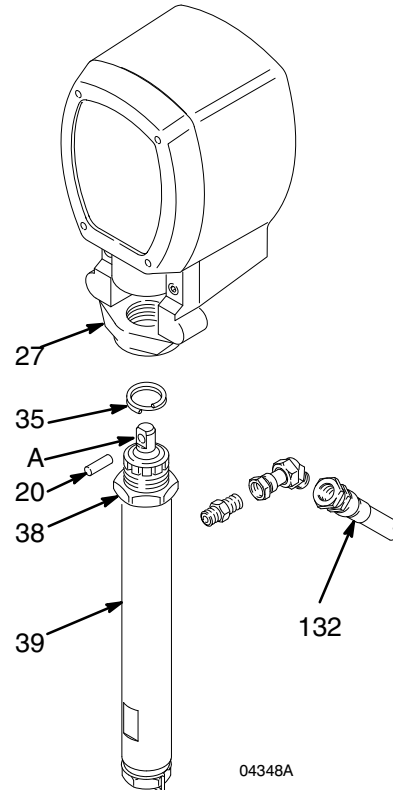

Fig 11

- 1 Torque to 70 ft-lb
- 2 Face of bearing housing

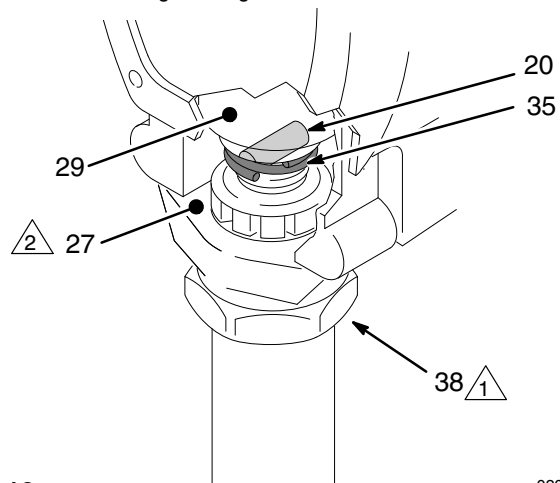

Fig 12

02083

## ⚠ WARNING



### MOVING PARTS HAZARD

If the pin works loose, it or other parts could break off due to the force of the pumping action. These parts could be projected through the air and result in serious bodily injury or property damage, including damage to the pump, connecting rod or bearing housing.

## ⚠ CAUTION

If the locknut (38) loosens during operation, the threads of the bearing housing (29) will be damaged. Be sure to tighten the locknut firmly.



# Motor

## WARNING



### INJECTION HAZARD

To reduce the risk of serious injury, whenever you are instructed to relieve pressure, follow the **Pressure Relief Procedure** on page 8.

## WARNING



### ELECTRIC SHOCK HAZARD

To reduce the risk of Electric Shock: wait 5 minutes after turning sprayer off before servicing to allow stored current to discharge.

**NOTE:** Refer to Fig 13 and parts list except where noted.

1. Relieve pressure.
  2. Remove motor shield (14) and front cover (31). Disconnect hose (132).
  3. Remove outlet cover on pressure control wiring box. Disconnect four motor leads. See Fig. 14.
  4. Unscrew conduit fitting (125) from motor and pull four motor leads from conduit (22).
  5. Remove screws (51) from drive housing. Remove screws (21 and 30) from motor (1).
  6. Tap rear of pump (39) with plastic mallet to loosen drive housing (18) from motor (1). Pull off drive housing.
- NOTE:** Do not drop the gear cluster (9), which may stay engaged in the motor bell or in the drive housing. Do not lose the thrust balls (10) or drop them between the gears. The balls usually stay in the shaft recesses, but they can be dislodged. If the balls are not in place, the bearings will wear prematurely.
7. Lower pressure control (130) by unscrewing motor mounting screws (37).
  8. Lift off motor (1).
  9. Mount and center new motor on frame and attach pressure control (130) with motor mounting screws (37).
  10. Insert motor leads through conduit fitting (125) and conduit (22) to pressure control. Screw connector (125) two or three threads into motor. Tighten locknut up to motor. Connect four motor leads. See Fig. 14.
  11. Liberally grease gear cluster (9) and pinion gear (G). Pack all bearings in motor bell. Be sure thrust balls (10) are in place.
  12. Place bronze-colored washer (18b) and then silver-colored washer (18a) on shaft protruding from big gear in drive housing (18).
  13. Align gears and push drive housing (18) straight onto motor bell (F) and locating pins.
  14. Continue to reassemble sprayer.

# Motor

- 1 Seals (93) located inside conduit (22)
- 2 Bronze colored washer
- 3 Apply 6 oz. bearing grease
- 4 Silver colored washer

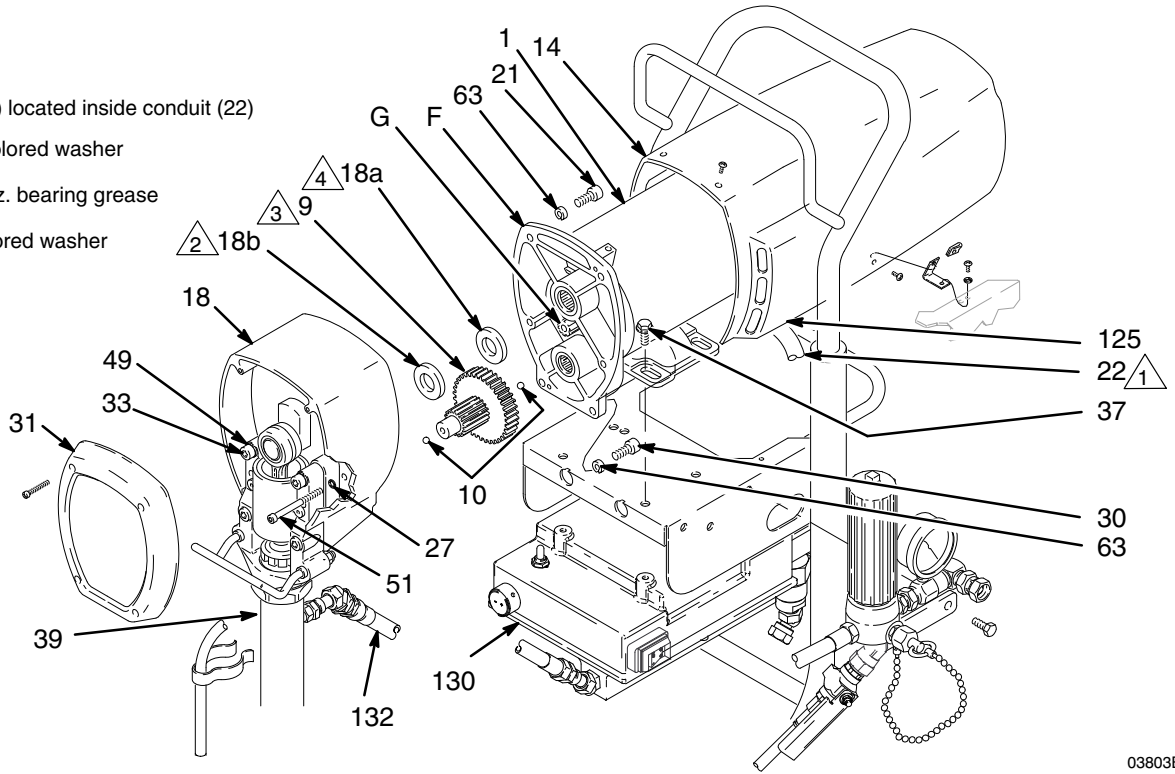

Fig 13

03803B

# Pressure Control

## ⚠ CAUTION

Do not install the pressure control until motor is checked. A defective motor may damage the pressure control. Make sure to test the motor prior to pressure control installation.

## ⚠ WARNING



### ELECTRIC SHOCK HAZARD

To reduce the risk of Electric Shock: wait 5 minutes after turning sprayer off before servicing to allow stored current to discharge.

## Motor Test

With motor shield off and four motor leads disconnected:

1. Check continuity with multimeter from each black motor lead to ground (one at a time). Any reading less than infinite resistance – even very high resistance – means motor is shorted to ground. Replace motor.

## ⚠ CAUTION

A motor that is shorted to ground will damage the pressure control.

2. Remove fan cover from motor.
3. Remove pump pin ( See page 16 for instructions to remove pin).
4. With black motor leads not connected, use motor fan to spin motor quickly. Motor should spin freely in both directions. If not, replace motor.
5. Connect black motor leads together.
6. Use motor fan to turn motor. It should be much harder to turn than in step 4. If there is uneven or no resistance to turning, check brushes and replace if necessary.
7. If there is still uneven or no resistance to turning, replace motor.

8. Install pump pin and fan cover.

## ⚠ WARNING

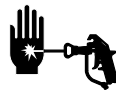

### INJECTION HAZARD

To reduce the risk of serious injury, whenever you are instructed to relieve pressure, follow the **Pressure Relief Procedure** on page 8.

1. Relieve pressure.
2. Remove ten screws (64) and motor shield (14). See Fig. 15 and parts list.
3. Loosen outlet cover on pressure control wiring box and disconnect wires. See Fig 14.
4. Loosen black conduit (22) from pressure control fitting and pull out wires
5. Remove hose (132), 45° swivel union (131), check valve (42), and nipple (59) from rear of pressure control (130).
6. Remove hose (134) and 45° swivel union (131) from front of pressure control (130).
7. Support pressure control from falling(130) and carefully remove motor mount screws (37). Remove pressure control.
8. Install new pressure control (130) with screws (37).
9. Continue to reassemble sprayer.

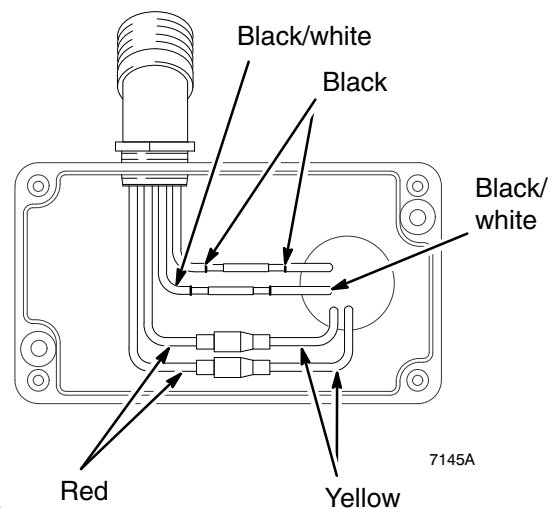

Fig 14

# Pressure Control

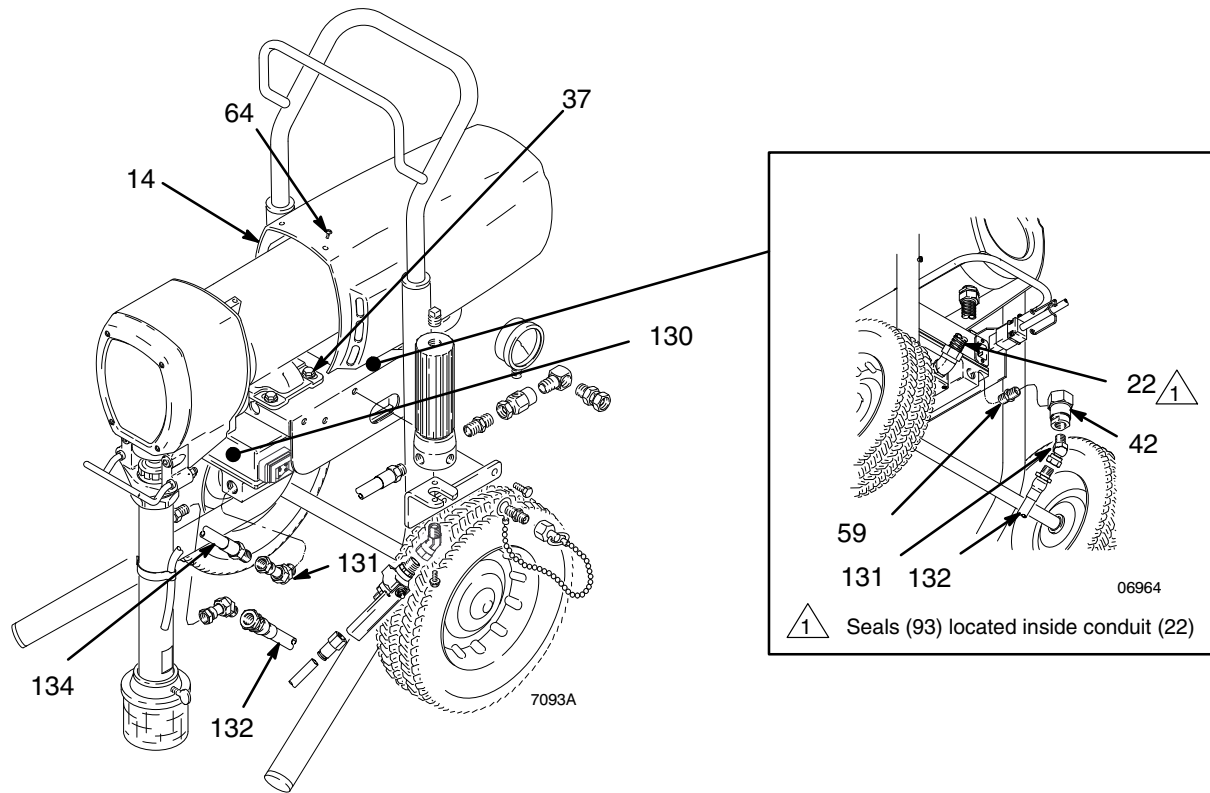

Fig 15

## Pressure Control Repair

### General Repair and Replacement

#### **WARNING**



#### **INJECTION HAZARD**

To reduce the risk of serious injury, whenever you are instructed to relieve pressure, follow the **Pressure Relief Procedure** on page 8.

1. Relieve pressure.
2. Remove power cord (23) and plug retainer (23a) by removing screws (230) and washers (229).
3. Remove screws (213) and lockwashers (214). Carefully remove control housing (202) from control motor board (201) so internal wiring is not damaged. Lay housing on side next to control motor board. See Fig. 16 and parts list.
4. Remove and replace only those components and wires necessary for repair. Make a diagram showing wire hook-ups for items removed to insure correct wiring when reinstalling. See Fig. 17 for wiring information.

5. Install control housing (202) to motor control board (201) using screws (213) and lockwashers (214).

### Pressure Control Transducer and O-Ring Replacement

#### **WARNING**



#### **FIRE AND EXPLOSION HAZARD**

Proper O-ring replacement is essential to reduce the risk of fire or explosion which can result in serious injury and property damage. Also read **FIRE OR EXPLOSION HAZARD** on page 2.



**NOTE:** Do not replace o-ring unless damaged or if leakage is seen around weep hole, o-ring or transducer.

1. See Fig. 16 and pressure control part list. Disassemble pressure control as in steps 1 through 4 on page 20 and remove old transducer (219) and, if necessary, old o-ring (220).

# Pressure Control Repair

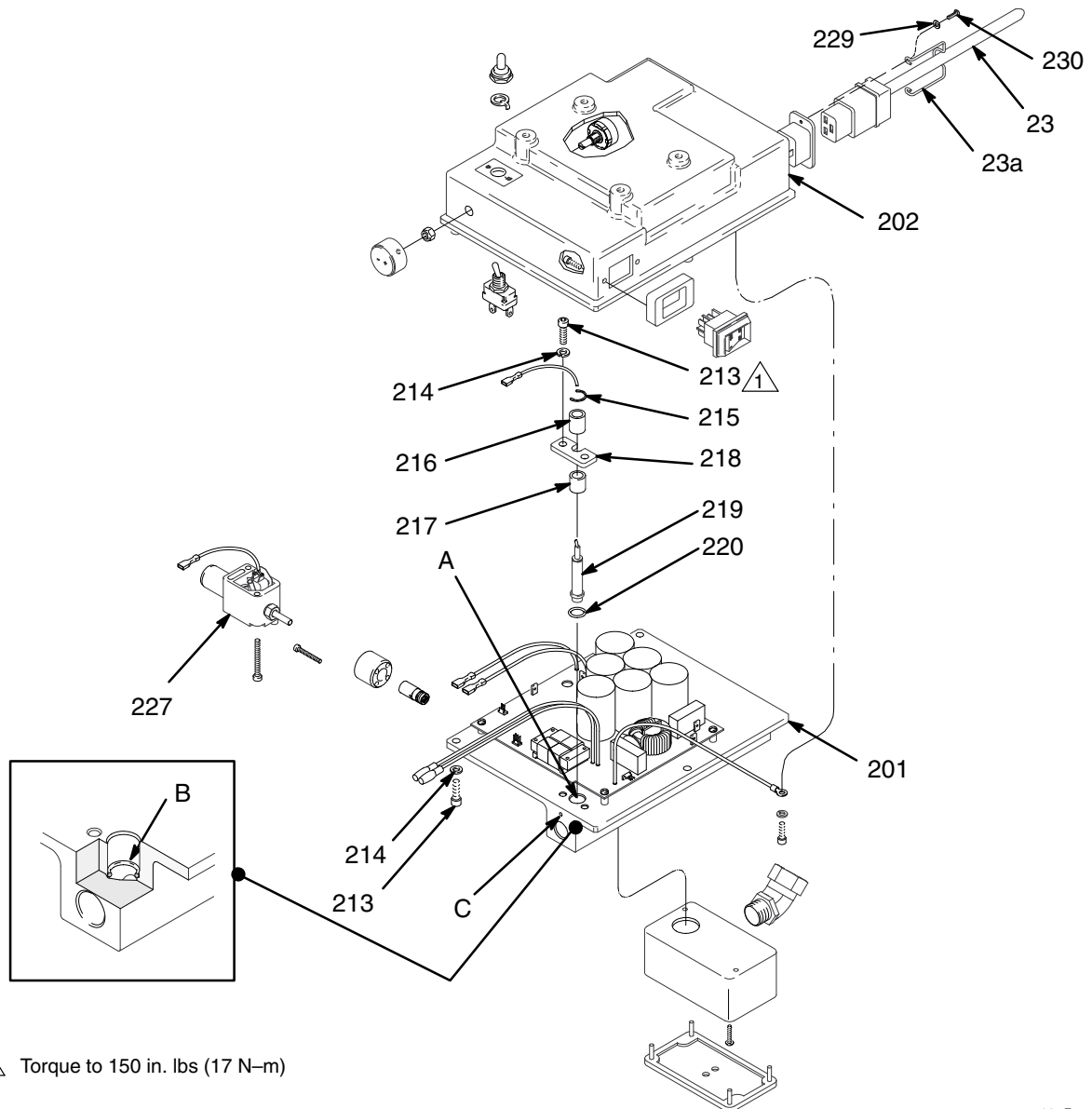

1  Torque to 150 in. lbs (17 N-m)

**Fig 16**

7135B

2. Insert new o-ring (220) into bore (A) of motor control (201) at an angle so that forward facing part of o-ring is below weep hole (C). Then slide o-ring down bore into o-ring groove (B). Make sure o-ring is in groove around its entire circumference.
3. Carefully slide new transducer and plastic spacer (217) down bore. Loosely attach bracket (218), screws (213), and washers (214).
4. Seat transducer into o-ring by drawing down screws and washers until bracket is flush with motor control surface.
5. Carefully remove transducer and verify that o-ring is seated correctly and not pushed out of groove. If not seated correctly use new o-ring and repeat steps 2 through 5.
6. When o-ring is correctly installed, reinstall transducer and tighten screws to 150 in. lbs (17 N-m). Install spacer (216) and C-clip (215). Re-connect electrical lead and re-assemble sprayer.
7. Follow Airless Operation start-up procedures for sprayer on page 7 using compatible fluid.
8. Inspect weep hole (C) for any leakage.
9. If any leakage is present, replace o-ring repeating steps 1 through 9.

**NOTE:** O-ring (220) is made of PTFE which is more difficult to work with.

# Pressure Control Wiring

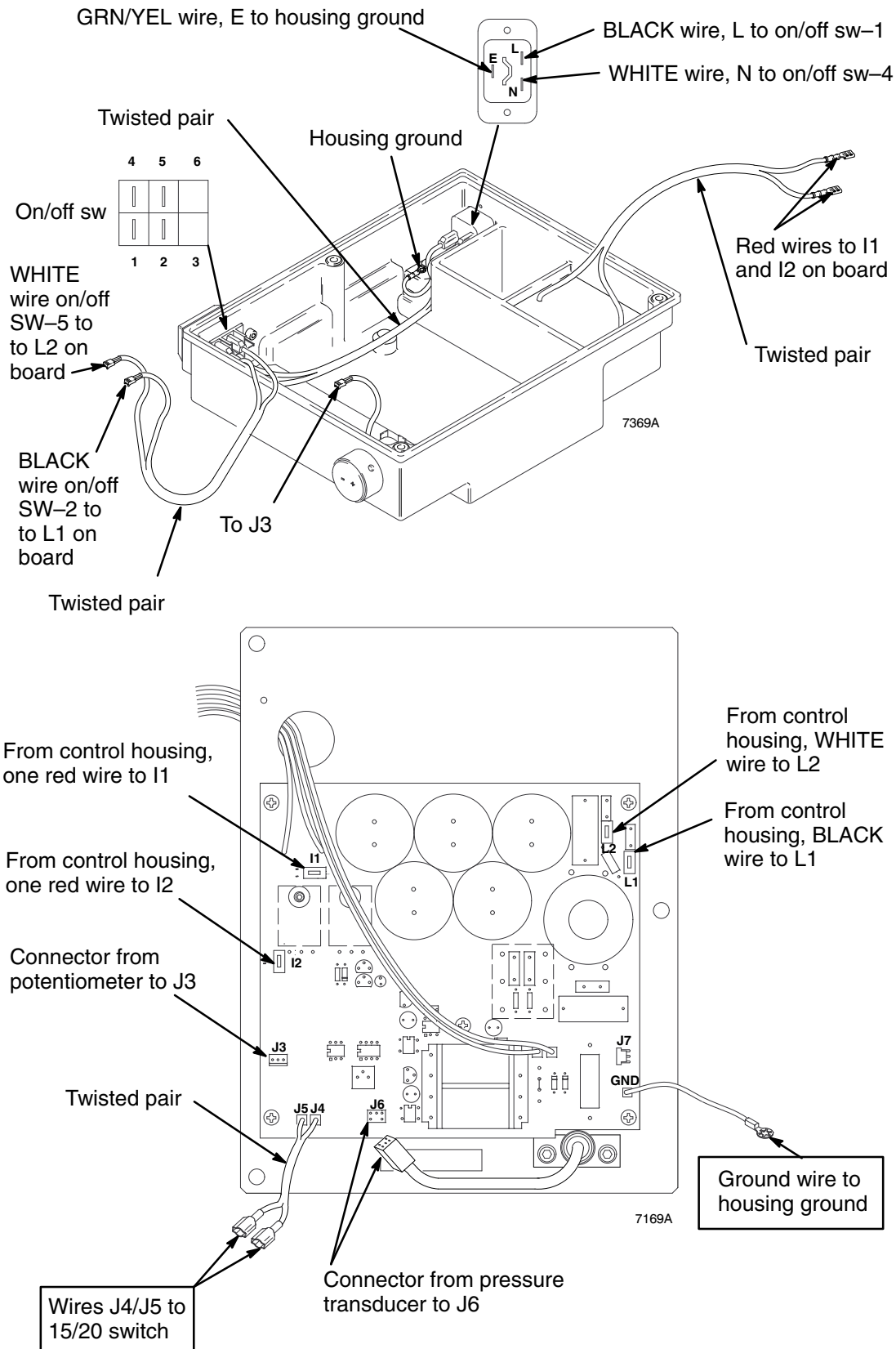

Fig 17

# Bearing Housing and Connecting Rod

## ⚠ WARNING



### INJECTION HAZARD

To reduce the risk of serious injury, whenever you are instructed to relieve pressure, follow the **Pressure Relief Procedure** on page 8.

**Procedure** on page 8.

**NOTE:** Stop the sprayer at the bottom of its stroke to get the crank (H) in its lowest position. To lower the crank manually, rotate the blades of the motor fan with a screwdriver.

1. Remove pump. See page 16.
2. Remove front cover (31). Remove bearing housing screws (33). See Fig. 18 and part list.
3. Tap lower rear of bearing housing (27) with plastic mallet to loosen it from drive housing (18). Pull bearing housing and connecting rod (29) straight off drive housing.
4. Inspect crank (H) for excessive wear and replace parts as needed.
5. Evenly lubricate inside of bronze bearing (K) with motor oil. Liberally pack roller bearing (J) with bearing grease.
6. Assemble connecting rod (29) and bearing housing (27).
7. Clean mating surfaces of bearing and drive housings.
8. Align connecting rod with crank (H) and align locating pins in drive housing with holes in bearing housing (27). Push bearing housing onto drive housing or tap into place with plastic mallet.
9. Install bearing housing screws (33). Torque evenly to 300 in-lb (34 N.m).
10. Reinstall all parts. See page 16 to install pump.

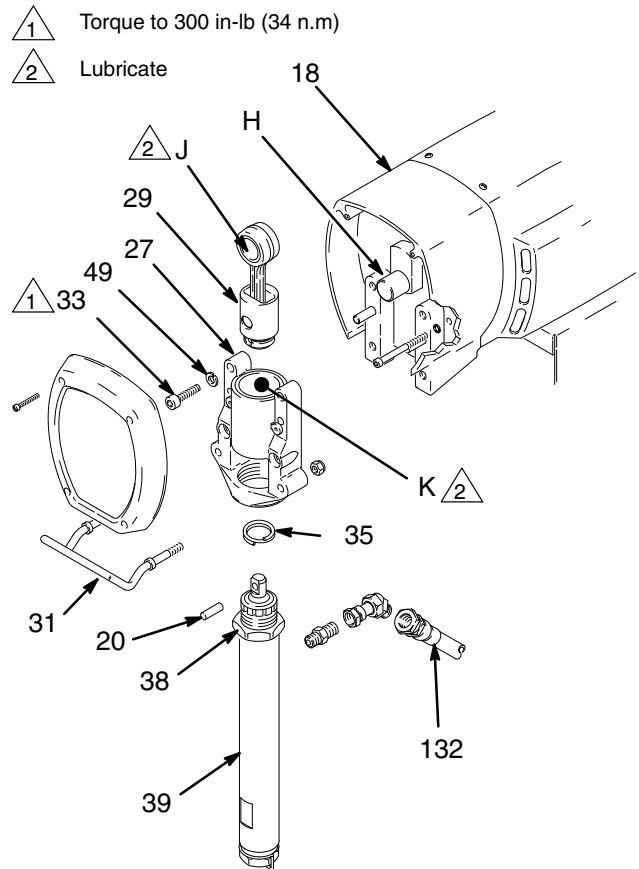

Fig 18

04351A

# Drive Housing

## ⚠ WARNING



### INJECTION HAZARD

To reduce the risk of serious injury, whenever you are instructed to relieve pressure, follow the **Pressure Relief Procedure** on page 8.

**Procedure** on page 8.

**NOTE:** See Fig 19 and parts list.

**NOTE:** Stop the sprayer at the bottom of its stroke to get the crank (H) in its lowest position. To lower it manually, carefully rotate the blades of the fan with a screwdriver.

1. Remove front cover (31). Remove motor shield (14).
2. Disconnect pump outlet hose (132).
3. Remove screws (33) from bearing housing (27).
4. Tap rear of pump (39) with plastic mallet to loosen from drive housing (18). Pull bearing housing assembly (27) straight off drive housing (18).

5. Remove screws (51) from drive housing.
6. Remove screws (30, 21) from motor (1).
7. Tap drive housing (18) with plastic mallet to loosen from motor and pull straight off.

**NOTE:** Do not drop the gear cluster (9), which may stay engaged in the motor bell or in the drive housing. Do not lose the thrust balls (10) or drop them between gears. The balls usually stay in the shaft recesses, but could be dislodged. If the balls are not in place, the bearings will wear prematurely.

8. Use approximately 6 oz. of bearing grease supplied with drive housing replacement kit to grease gear cluster (9). Check that thrust balls (10) are in place.
9. Place bronze-colored washer (18b) and silver-colored washer (18a) on shaft protruding from big gear in drive housing (18).
10. Align gears and push new drive housing straight onto motor and locating pins.
11. Continue to reassemble sprayer. Torque the screws (33) to 34 N.m (300 in-lb).

- 1 Torque to 300 in-lb (34 N.m)
- 2 Bronze colored washer
- 3 Apply 6 oz. bearing grease
- 4 Silver colored washer

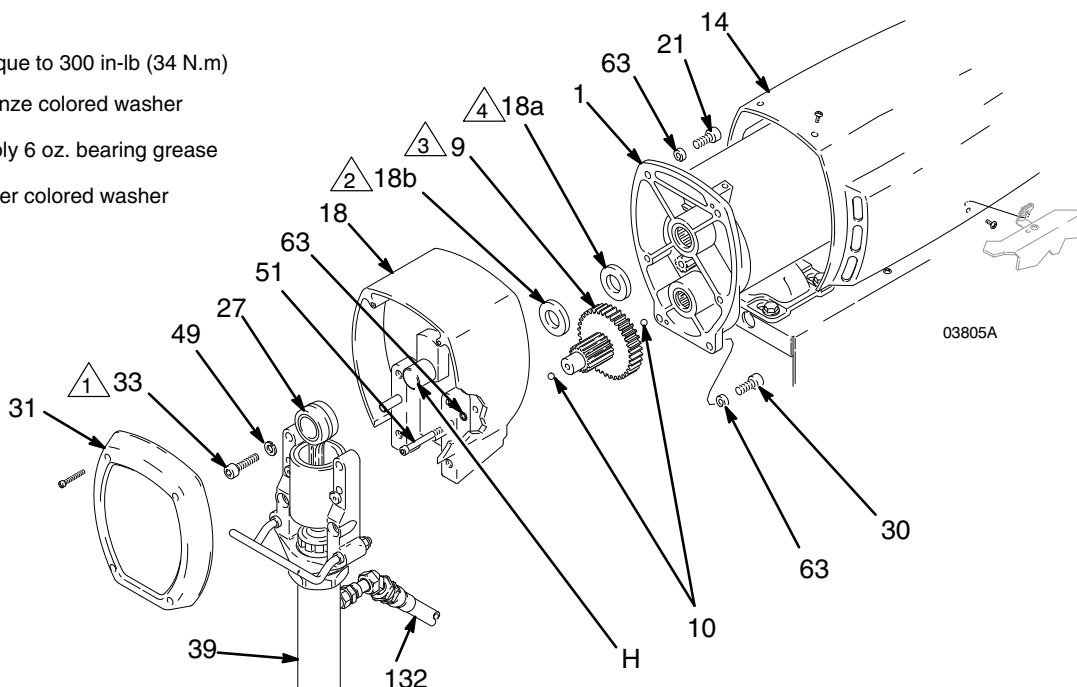
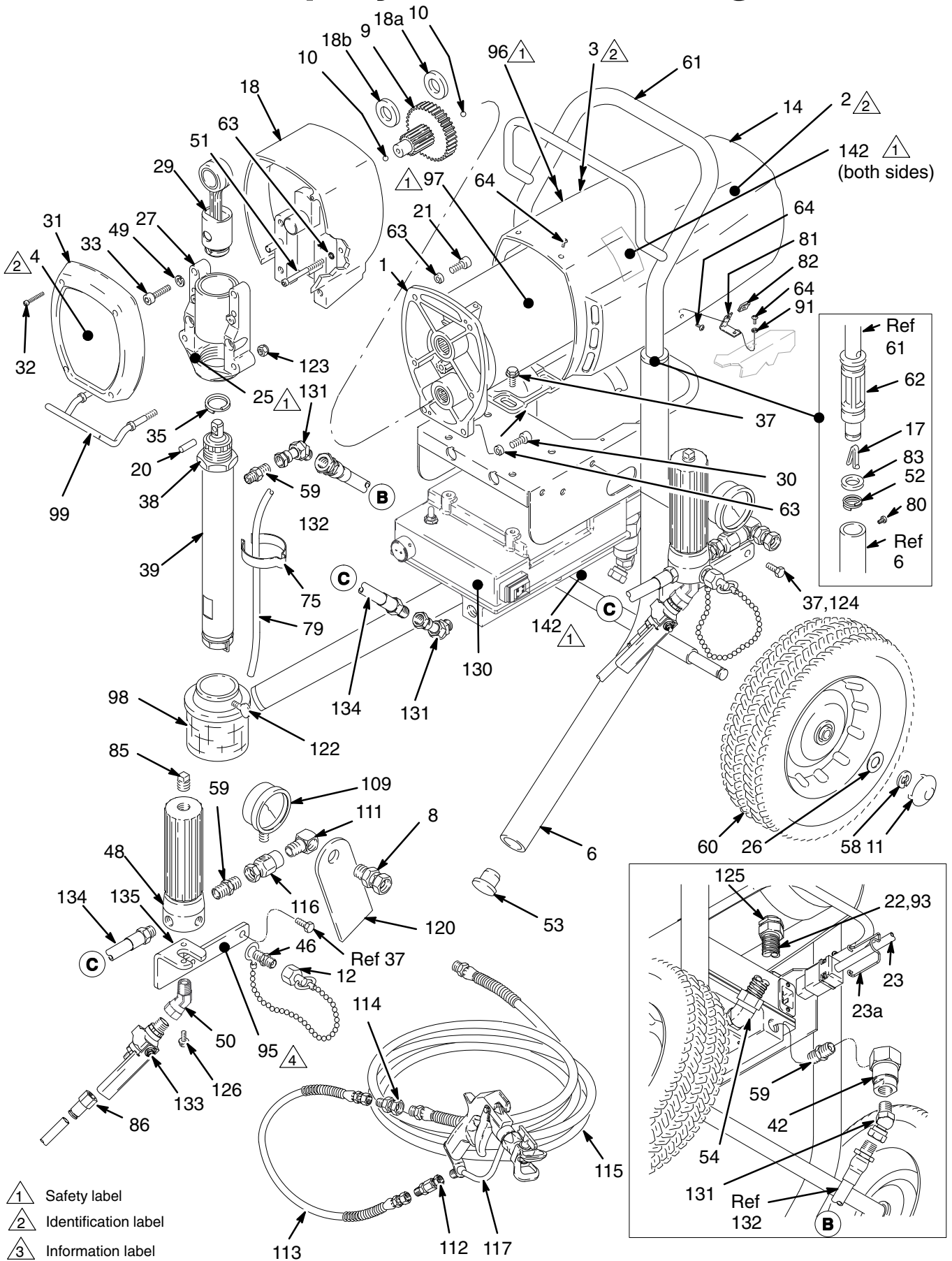





Fig 19





# Sprayer Parts Drawing



-  Safety label
-  Identification label
-  Information label
-  Caution label

04353A

# Sprayer Parts List

**Model 231–406, Series A**  
 Complete Sprayer with Gun Kit  
 Includes items 1 – 142

Ref No.	Part No.	Description	Qty	Ref No.	Part No.	Description	Qty
1	220–854	MOTOR KIT	1	53	108–691	PLUG, tubing	2
2	290–048	LABEL, identification, motor cover	1	54	108–460	CONNECTOR, conduit	1
3	290–047	LABEL, identification, motor cover	1	58	101–242	RETAINING RING	2
4	290–046	LABEL, identification, front cover	1	59	156–849	NIPPLE, pipe	1
6	220–636	CART	1	60	179–811	WHEEL	2
8	155–665	ADAPTER 3/8" npsm swivel x 3/8 npt(m)	1	61	220–633	HANDLE, cart	1
9	220–637	GEAR REDUCER	1	62	192–027	SLEEVE, cart handle	2
10	100–069	BALL, steel; 1/4" dia.	1	63	105–510	LOCKWASHER, 1/4"	6
11	104–811	HUBCAP	2	64	108–865	SCREW, 8–32 x 3/8"	10
12	220–285	CAP	1	75	186–490	CLIP, spring	1
14	183–204	MOTOR SHIELD KIT	1	79	190–339	TUBE, bypass	1
17	111–590	BUTTON, snap	2	80	109–032	SCREW, pnh; 10–24 x 1/4"	4
18	220–879	DRIVE HOUSING KIT <i>Includes 18a, 18b, and one of 10</i>	1	81	185–384	BRACKET	2
18a	183–209	.THRUST BEARING	1	82	110–240	NUT	2
18b	106–227	.SPACER	1	83	183–350	WASHER, 7/8" ID	2
20	183–210	PIN, 3/8 x 1–1/8"	1	85	100–040	PLUG	1
21	100–644	SCREW, 1/4–20 x 3/4"	2	86	112–790	CONNECTOR, tube	1
22	065–312	CONDUIT, electrical <i>specify length when ordering: 140 mm</i>		91	100–020	LOCKWASHER, 0.194" ID	2
23	239–749	CORD, power	1	92	167–024	FILTER, 30 mesh ( <i>not shown</i> )	1
23a	192–149	PLUG, Retainer (part of 23)	1	93	107–447	SEAL ( <i>not shown</i> )	2
24	107–264	TERMINAL, female ( <i>not shown</i> )	2	95▲	183–466	LABEL, Caution	1
25▲	187–959	LABEL	1	96▲	185–952	LABEL, Danger	1
26	154–636	WASHER	2	97▲	185–951	LABEL, Danger	1
27	220–639	BEARING HOUSING KIT	1	98	189–917	STRAINER	1
29	220–640	CONNECTING ROD KIT	1	99	189–918	CARRIER, pail	1
30	100–643	SCREW, 1/4–20 x 1"	2	109	102–814	GAUGE, pressure	1
31	183–168	COVER, housing	1	111	155–699	ELBOW, street	1
32	108–850	SCREW, No. 8–32 x 1–1/4"	4	112	204–940	SWIVEL, straight	1
33	110–141	CAPSCREW, 3/8–16 x 1–1/5"	4	113	223–761	HOSE, grounded, 1/4" x 0.9 m (3 ft)	1
35	183–169	RETAINING SPRING	1	114	159–153	SWIVEL, union, 1/4" x 3/8 npt(f)	1
37	110–963	CAPSCREW, flange head, 5/16–18 x 3/4"	6	115	186–851	HOSE, grounded, 3/8" x 45.5 m (50 ft)	1
38	189–969	NUT, retaining, 1 13/16 unc–2b	1	116	237–475	CONNECTOR, adapter	1
39	237–488	DISPLACEMENT PUMP <i>see manual 307–806 for parts</i>	1	117	237–476	GUN, texture spray	1
42	223–125	CHECK VALVE	1	120	178–034	TAG, warning	1
46	162–453	NIPPLE, 1/4 npsm x 1/4 npt, 1–3/16" long	1	122	100–220	SCREW, thumb	1
48	235–724	FLUID FILTER 1 <i>see manual 307–273 for parts includes one of items 46 and 85</i>		123	112–746	LOCKNUT, 5/16–18	2
49	106–115	LOCKWASHER, 3/8"	4	124	111–040	LOCKNUT, nylon, 5/16–18	2
50	114–030	UNION, swivel, 45°	1	125	110–138	CONDUIT CONNECTOR	1
51	108–849	CAPSCREW, 1/4–20 x 3"	2	126	110–997	CAPSCREW, flange head	2
52	110–243	RETAINING SPRING	2	130	239–750	PRESSURE CONTROL KIT <i>See Parts List on page 29</i>	1
				131	161–889	UNION, swivel	3
				132	239–287	HOSE, high pressure, 16.5 in.	1
				133	239–280	VALVE, ball	1
				134	239–278	HOSE, high pressure, 12 in.	1
				135	192–135	BRACKET, filter	1
				141	107–266	TERMINAL, male ( <i>not shown</i> )	2
				142▲	290–447	LABEL, Warning	3

▲ Replacement Danger and Warning labels, tags and cards are available at no cost.

# Pressure Control Parts List

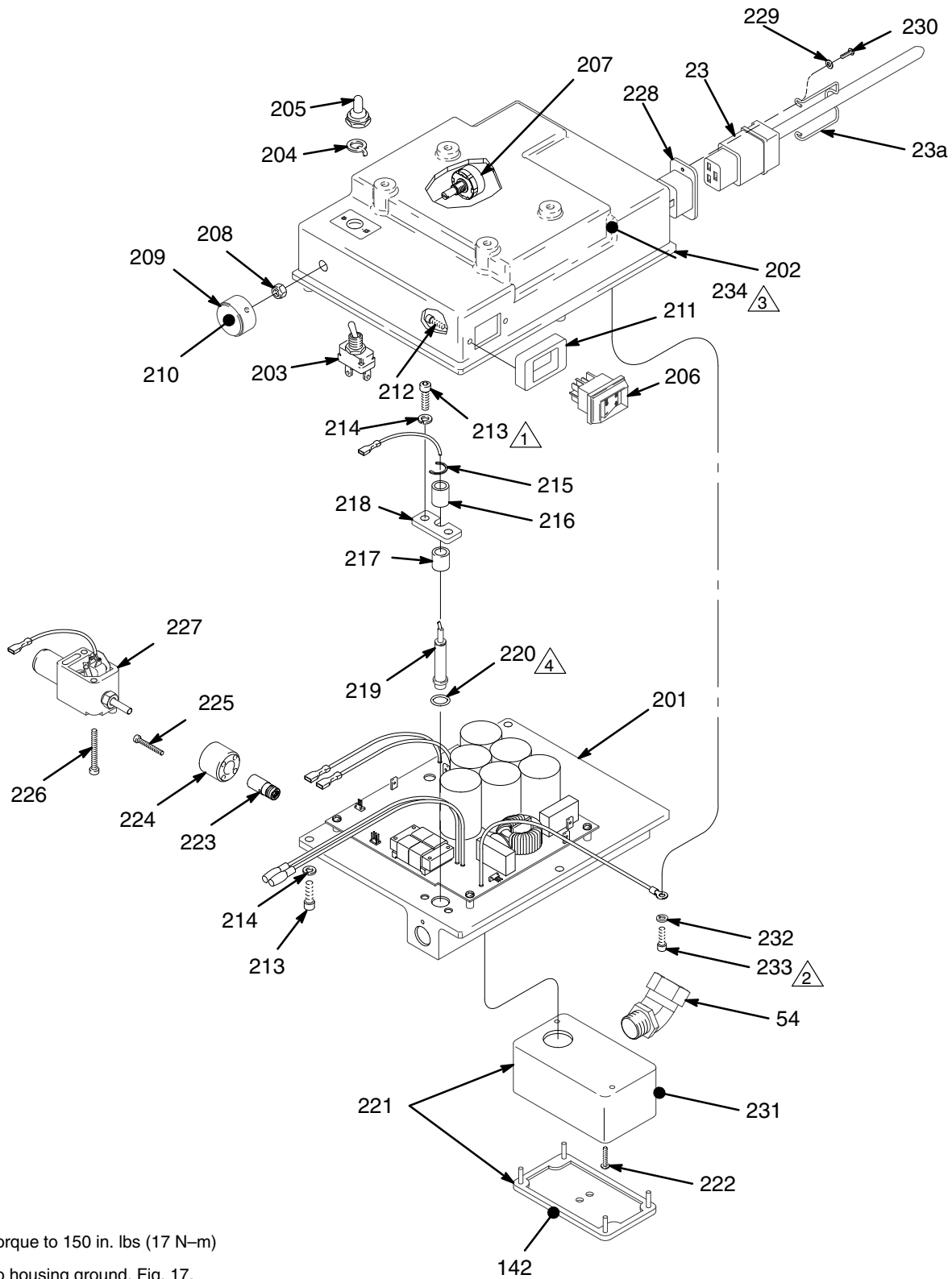

- 1 ⚠ Torque to 150 in. lbs (17 N-m)
- 2 ⚠ To housing ground, Fig. 17.
- 3 ⚠ Located this point, inside housing
- 4 ⚠ WARNING! See Transducer Pressure Control and O-Ring Replacement on page 20 for correct replacement procedure.

Fig 20

7135A

# Pressure Control Parts List

## Part Number 239-750

Pressure Control

Includes items 201 - 234

Ref No.	Part No.	Description	Qty	Ref No.	Part No.	Description	Qty
	239-750	PRESSURE CONTROL <i>See Ref. No. 130 on page 27 for location on Sprayer</i>	1	217	192-144	SPACER, transducer	1
				218	192-145	BRACKET, transducer	1
				219	236-364	TRANSDUCER, pressure control	1
201	239-751	MOTOR CONTROL BOARD	1	220	104-319	PACKING, o-ring WARNING! See <i>Transducer Pressure Control and O-Ring Replacement on page 20 for correct replacement procedure.</i>	1
202	239-752	CONTROL HOUSING <i>For complete assembly, order part number 239-442.</i>	1				
203	111-930	. SWITCH, toggle (20/15)	1	221	239-428	ELECTRICAL ENCLOSURE KIT	1
204	105-658	. RING, locking	1	222	M71-503	SCREW	2
205	105-659	. BOOT, toggle	1	223	235-009	SWITCH TRANSDUCER	1
206	111-961	. SWITCH, rocker (on/off)	1	224	192-150	BLOCK, transducer	1
207	236-352	. POTENTIOMETER (pressure adjust)	1	225	108-850	SCREW, machine, fil hd	4
208	112-382	. NUT, shaft sealing	1	226	111-704	SCREW, machine, fil hd	2
209	112-373	. KNOB, control	1	227	239-530	SWITCH	1
210	290-147	. LABEL, control knob	1	228	113-799	INLET, ac power	1
211	192-226	. SPACER, switch	1	229	114-027	WASHER, flat	2
212	112-788	. SCREW, cap hd	2	230	112-546	SCREW, machine, phillips, pan hd	2
213	100-644	SCREW, cap	5	231▲	189-930	LABEL, caution	1
214	100-016	WASHER, lock	5	232	157-021	WASHER, lock, internal	1
215	114-031	CLIP, cee	1	233	111-593	SCREW, grounding	1
216	192-223	SPACER, transducer	1	234	186-620	LABEL, ground	1

▲ Replacement Danger and Warning labels, tags and cards are available at no cost.

# Accessories

# Technical Data

## DANGER LABELS

The English language DANGER label shown on page 4 is also on your sprayer. If you have painters who do not read English, order one of the following labels to apply to your sprayer. The drawing below shows the best placement of these labels for good visibility.

Order the labels directly from your Graco distributor.

- French** 185-955
- Spanish** 185-962
- German** 186-042
- Greek** 186-046
- Korean** 186-050

Apply other language here

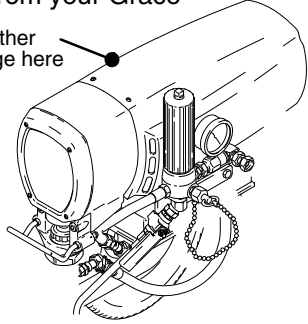

Power Requirements (full output) . . . . 120 VAC, 60Hz,  
1 phase, 18A minimum

Working Pressure Range . . . 0-3000 psi (0-21.0 MPa,  
0-210 bar)

Cycles/gallon (liter) . . . . . 104 (27.5)

Power Cord . . . . . 12 ga., 3 wire, 10 ft. (3 m)

Fluid Outlet Size . . . . . 3/8 npsf from control

### Sound Data

Sound pressure level . . . . . 85.3 db(A)

Sound power level . . . . . 95.2 db(A)

Measured under maximum operating conditions per  
ISO-3744

### Wetted Parts:

*Displacement Pump* . . . Carbon steel, Polyurethane,  
Polyethylene, PTFE® Delrin®, Leather

*Filter* . . . . . Aluminum, Carbon steel, Stainless Steel,

**NOTE:** PTFE® and Delrin® are a registered trade-  
marks of the Company.

### Texture Spray Gun Kit 237-476

Replacement 3000 psi (21.0 MPa, 210 bar) texture  
spray gun for the Mark V Texture Sprayer.

### Ball Valve Repair Kit 237-693

Replacement parts to repair pressure drain valves  
239-280 and 237-469.

### Gun Handle Kit 237-680

Replacement handle with safety for the 3000 psi  
(21.0 MPa, 210 bar) texture spray gun 237-476.

### Motor Brush Kit 220-853

For replacing motor brushes.

# Dimensions

Weight (w/o packaging, hose or gun) . . . . 137 lb (62.3 kg)

Height . . . . . 31 in. (787 mm)

Length . . . . . 25 in. (635 mm)

Width . . . . . 22.5 in. (572 mm)



# Graco Warranty

Graco warrants all equipment listed in this manual which is manufactured by Graco and bearing its name to be free from defects in material and workmanship on the date of sale by an authorized Graco distributor to the original purchaser for use. With the exception of any special extended or limited warranty published by Graco, Graco will, for a period of twelve months from the date of sale, repair or replace any part of the equipment determined by Graco to be defective. This warranty applies only when the equipment is installed, operated and maintained in accordance with Graco's written recommendations.

This warranty does not cover, and Graco shall not be liable for general wear and tear, or any malfunction, damage or wear caused by faulty installation, misapplication, abrasion, corrosion, inadequate or improper maintenance, negligence, accident, tampering, or substitution of non-Graco component parts. Nor shall Graco be liable for malfunction, damage or wear caused by the incompatibility of Graco equipment with structures, accessories, equipment or materials not supplied by Graco, or the improper design, manufacture, installation, operation or maintenance of structures, accessories, equipment or materials not supplied by Graco.

This warranty is conditioned upon the prepaid return of the equipment claimed to be defective to an authorized Graco distributor for verification of the claimed defect. If the claimed defect is verified, Graco will repair or replace free of charge any defective parts. The equipment will be returned to the original purchaser transportation prepaid. If inspection of the equipment does not disclose any defect in material or workmanship, repairs will be made at a reasonable charge, which charges may include the costs of parts, labor, and transportation.

Graco's sole obligation and buyer's sole remedy for any breach of warranty shall be as set forth above. The buyer agrees that no other remedy (including, but not limited to, incidental or consequential damages for lost profits, lost sales, injury to person or property, or any other incidental or consequential loss) shall be available. Any action for breach of warranty must be brought within two (2) years of the date of sale.

**GRACO MAKES NO WARRANTY, AND DISCLAIMS ALL IMPLIED WARRANTIES OF MERCHANTABILITY AND FITNESS FOR A PARTICULAR PURPOSE IN CONNECTION WITH ACCESSORIES, EQUIPMENT, MATERIALS OR COMPONENTS SOLD BUT NOT MANUFACTURED BY GRACO.** These items sold, but not manufactured by Graco (such as electric motors, gas engines, switches, hose, etc.), are subject to the warranty, if any, of their manufacturer. Graco will provide purchaser with reasonable assistance in making any claim for breach of these warranties.

## LIMITATION OF LIABILITY

In no event will Graco be liable for indirect, incidental, special or consequential damages resulting from Graco supplying equipment hereunder, or the furnishing, performance, or use of any products or other goods sold hereto, whether due to a breach of contract, breach of warranty, the negligence of Graco, or otherwise.

## ADDITIONAL WARRANTY COVERAGE

Graco does provide extended warranty and wear warranty for products described in the "Graco Contractor Equipment Warranty Program".

# Graco Phone Number

**TO PLACE AN ORDER**, contact your Graco distributor, or call this number to identify the distributor closest to you:  
**1-800-367-4023 Toll Free**

*All written and visual data contained in this document reflects the latest product information available at the time of publication.  
Graco reserves the right to make changes at any time without notice.*

**Sales Offices:** Atlanta, Chicago, Detroit, Los Angeles  
**Foreign Offices:** Belgium, Canada, England, Korea, Switzerland, France, Germany, Hong Kong, Japan

**GRACO INC. P.O. BOX 1441 MINNEAPOLIS, MN 55440-1441**

PRINTED IN U.S.A. 308-785 May 1997