

# INSTRUCTIONS—PARTS LIST



309115

Rev. C

  
This manual contains important warnings and information.  
**READ AND KEEP FOR REFERENCE.**  
INSTRUCTIONS

**GRACO**  
First choice when quality counts.™

GTS-ProCart™

## HVLP Compressor/Cart

240V AC 50/60 Hz

**Model 233059, Series A**

Cart with compressor, 2<sup>1</sup>/<sub>2</sub>-gallon remote pressure pot, and material and air hoses

15 psi (104 kPa, 1.0 bar) Maximum Working Pressure

### Related Manuals

- HVLP Turbine Sprayers ..... 308832
- GTS-960 Bleeder Gun ..... 308336
- GTS-980 Non-Bleeder Gun ..... 308810

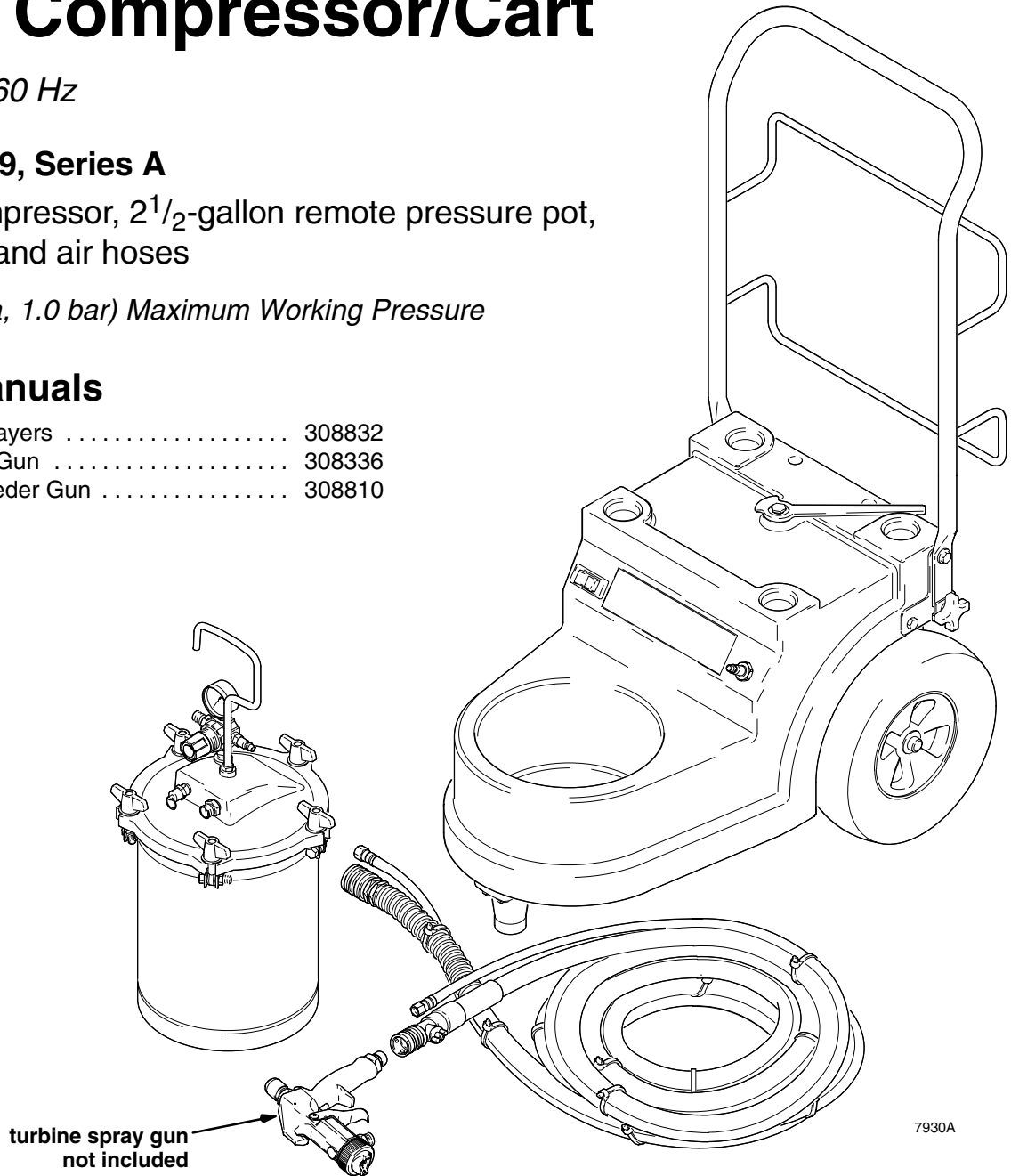

**GRACO INC. P.O. BOX 1441 MINNEAPOLIS, MN 55440-1441**

©COPYRIGHT 2000, GRACO INC.

Graco Inc. is registered to I.S. EN ISO 9001

# Table of Contents

|   |    |
|---|----|
| Warnings .....                              | 2  |
| General Information .....                   | 4  |
| Component Identification and Function ..... | 5  |
| Setup .....                                 | 6  |
| Shutdown .....                              | 11 |
| Maintenance .....                           | 12 |
| Troubleshooting .....                       | 13 |
| Repair .....                                | 14 |
| Accessories .....                           | 15 |
| Parts Drawing .....                         | 16 |
| Parts List .....                            | 17 |
| Specifications .....                        | 17 |
| Graco Standard Warranty .....               | 18 |
| Graco Phone Number .....                    | 18 |

# Symbols

## Warning Symbol



This symbol alerts you to the possibility of serious injury or death if you do not follow the instructions.

## Caution Symbol



This symbol alerts you to the possibility of damage to or destruction of equipment if you do not follow the instructions.

# WARNING



## FIRE AND EXPLOSION HAZARD

Improper grounding, poor ventilation, open flames or sparks can cause a hazardous condition and result in a fire or explosion and serious injury.

- Ground the equipment and the object being sprayed. See **Grounding** on page 6.
- If there is any static sparking or you feel an electric shock while using this equipment, **stop spraying immediately**. Do not use the equipment until you identify and correct the problem.
- Provide fresh air ventilation to avoid the buildup of flammable fumes from solvents or the fluid being sprayed.
- When flammable liquid is sprayed or used for flushing or cleaning the equipment, the compressor must be placed at least 20 feet (6.1 m) away from areas where hazardous concentrations of flammable vapors are likely to occur.
- Use additional air hose if necessary to ensure that the compressor is operated in a clean, dry, well-ventilated area.
- Never place the compressor inside a spray booth! Use this equipment outdoors or in extremely well-ventilated areas.
- Keep the spray area free of debris, including solvent, rags, and gasoline.
- Electrically disconnect all equipment in the spray area.
- Extinguish all open flames or pilot lights in the spray area.
- Do not smoke in the spray area.
- Do not turn on or off any light switch in the spray area while operating or if fumes are present.
- Do not operate a gasoline engine in the spray area.

# WARNING



INSTRUCTIONS

## EQUIPMENT MISUSE HAZARD

Equipment misuse can cause the equipment to rupture or malfunction and result in serious injury.

- This equipment is for professional use only.
- Read all instruction manuals, tags, and labels before you operate this equipment.
- Use the equipment only for its intended purpose. If you are not sure, call your Graco distributor.
- Do not alter or modify this equipment. Use only genuine Graco parts.
- Check equipment daily. Repair or replace worn or damaged parts immediately.
- Do not exceed the maximum working pressure of the lowest rated system component. The compressor/cart has a maximum working pressure of 15 psi (104 kPa, 1.0 bar).
- Use fluids and solvents that are compatible with the equipment wetted parts. See **Specifications** on page 17 for wetted parts.
- Do not use hoses to pull equipment.
- Route hoses away from traffic areas, sharp edges, moving parts, and hot surfaces. Do not expose Graco hoses to temperatures above 82°C (180°F) or below -40°C (-40°F).
- Wear hearing protection when operating this equipment.
- Do not lift pressurized equipment.
- Comply with all applicable local, state, and national fire, electrical, and safety regulations.
- Do not point the gun at anyone or at any part of the body.
- Do not put your hand or fingers over the gun fluid nozzle.
- Do not stop or deflect leaks with your hand, body, glove or rag.
- Do not “blow back” fluid; this is not an air spray system.
- Follow the **Pressure Relief Procedure** on page 11 if the fluid nozzle clogs and before you clean, check, or service this equipment.
- Tighten all fluid connections before you operate this equipment.
- Check the hoses, tubes, and couplings daily. Replace worn or damaged parts immediately.



## TOXIC FLUID HAZARD

Hazardous fluid or toxic fumes can cause serious injury or death if splashed in the eyes or on the skin, inhaled, or swallowed.

- Know the specific hazards of the fluid you are using.
- Store hazardous fluid in an approved container. Dispose of hazardous fluid according to all local, state, and national guidelines.
- Always wear protective eyewear, gloves, clothing, and respirator as recommended by the fluid and solvent manufacturer.
- Do not use 1,1,1-trichloroethane, methylene chloride, other halogenated hydrocarbon solvents or fluids containing such solvents in the turbine spray system, which contains aluminum and/or galvanized-coated parts. Such use could result in a serious chemical reaction, with the possibility of explosion, which could cause death, serious injury, and/or substantial property damage.

# General Information

## HVLP Compressor/Cart Information

The GTS-ProCart HVLP Compressor/Cart provides air pressure to a 2<sup>1</sup>/<sub>2</sub>-gallon remote pressure pot or to a 2-quart remote pressure pot. Fluid under pressure is propelled from the pressure pot to the turbine spray gun.

## HVLP System Operation

The GTS-ProCart HVLP Compressor/Cart, turbine sprayer, and turbine spray gun comprises the HVLP system. The HVLP system can spray most coatings or finishes currently being used for automotive refinish, industrial, aerospace, marine, wood, plastic, and architectural applications.

The spray gun of the HVLP system utilizes inbound air pressure from the compressor/cart and HVLP turbine sprayer to produce a high-quality paint finish. The spray gun produces a cone of air that carries and directs paint from the gun to the surface with minimum overspray. Application is easy, because only a few passes are required to obtain coverage. Increased system transfer efficiency reduces material requirements and clean-up time. The system complies with clean air laws for reduced volatile organic compounds (VOC) emissions.

See HVLP Turbine Sprayers manual 308832 for information on the operation and use of the HVLP turbine sprayer. See Turbine Gun manual 308336 or 308810 for information on operating the turbine spray gun.

Various configurations of HVLP compressor/carts, turbine sprayers, guns, and accessories are available to meet specific application requirements.

## Unpacking

Unpack the compressor/cart from the shipping carton, and inspect for any possible shipping damage. If anything is damaged, call your distributor.

The contents of the GTS-ProCart HVLP Compressor/Cart are as follows:

- 233059: cart with compressor
- 240476: material hose
- 240059: air hose
- This instruction manual

# Component Identification and Function

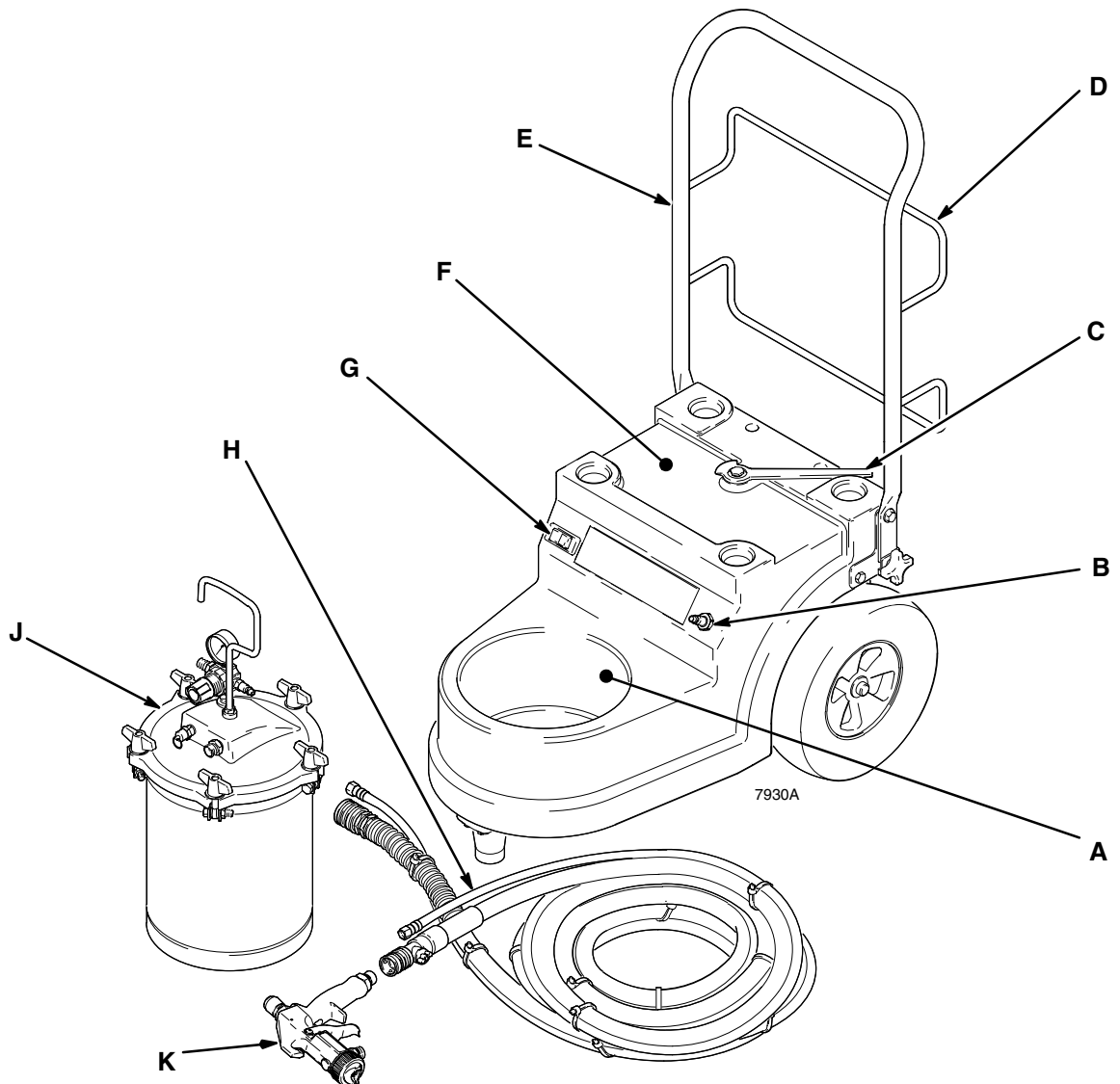

Fig. 1

|          |   |   |
|----------|---|---|
| <b>A</b> | Remote pressure pot holder                                | Provides space for 2-quart or 2 <sup>1</sup> / <sub>2</sub> -gallon pressure pots |
| <b>B</b> | Air outlet  | Connection for compressor air supply to remote pressure pots                      |
| <b>C</b> | Turbine latch   | Locks turbine sprayer in position on cart   |
| <b>D</b> | Hose holder   | Provides storage space for sprayer hose, gun, and accessories                     |
| <b>E</b> | Compressor/Cart handle                                    | Folds flat for minimum storage space  |
| <b>F</b> | Turbine sprayer base mount                                | Provides lock-mount for turbine sprayer on cart                                   |
| <b>G</b> | ON/OFF switch   | Power switch for compressor motor   |
| <b>H</b> | Air and material hoses                                    | Provide operating air and material to gun   |
| <b>J</b> | 2 <sup>1</sup> / <sub>2</sub> -gallon remote pressure pot | Holds 2 <sup>1</sup> / <sub>2</sub> gallons of application material               |
| <b>K</b> | Turbine spray gun (not included)                          | Applies and controls flow of material to be sprayed                               |

# Setup

## Grounding

### **⚠ WARNING**

Improper installation or alteration of the grounding plug will result in a risk of electric shock, fire or explosion that could cause serious injury or death.

- This equipment requires a 240V AC, 50/60 Hz, 8A circuit with a grounding receptacle. See Fig. 2.
- Extension cord must be 3-wire, 1.5 mm<sup>2</sup>, no longer than 15 m.

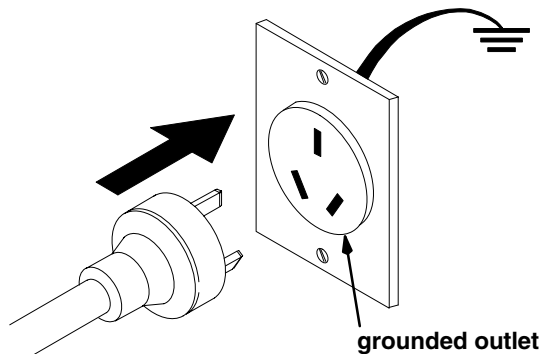

Fig. 2

## Setup/Use Options

The HVLV compressor/cart has a variety of user options. See Fig. 3.

### NOTES:

- See Turbine Sprayer manual 308832 for information on turbine setup and operation.
- See Turbine Gun manual 308336 or 308810 for information on turbine spray gun setup and operation.

## Prepare the Fluid

- Always strain the fluid before spraying; this includes color, reducer, and hardeners if used.
- When using a turbine spray system, use a slower-drying reducer or thinner to compensate for the faster drying time caused by the warm air of the turbine. Do not over reduce.

### **⚠ CAUTION**

The performance of the turbine sprayer varies with the viscosity of the material and the length of the hose. Keep the hose short to prevent pressure drop.

### Paint Reduction — Automotive Type Finishes

Reduce and catalyze all paint to manufacturer's specifications. To compensate for the faster drying time of turbine systems, use a reducer that is one step slower than what is used for conventional air spray.

### Paint Reduction — Industrial or Domestic Coatings

Reduce and catalyze all paint to manufacturer's specifications. If no reductions are given, first thoroughly mix the fluid to be sprayed, then gradually mix in the proper reducer. Test the fluid until you have the correct spraying consistency.

To test the consistency, remove the stir stick from the thinned paint. When the paint stream running off the stir stick breaks into droplets, the first few drops should be about one second apart.

# Setup

## Remote Pressure Pot

1. Place remote pressure pot in pressure pot holder on cart.
2. Follow **Connect Fluid and Air Supply** instructions on page 8.

## Storage Position for Cart Handle

1. Turn knob to free handle.
2. Fold handle down to store.

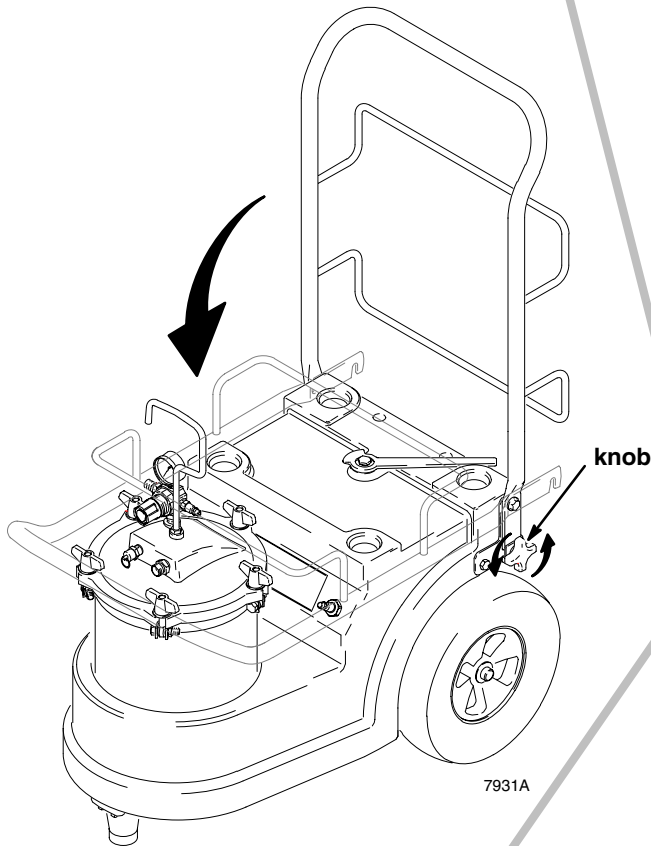

turbine sprayer  
(see manual 308832)

remote  
pressure  
pot

cart

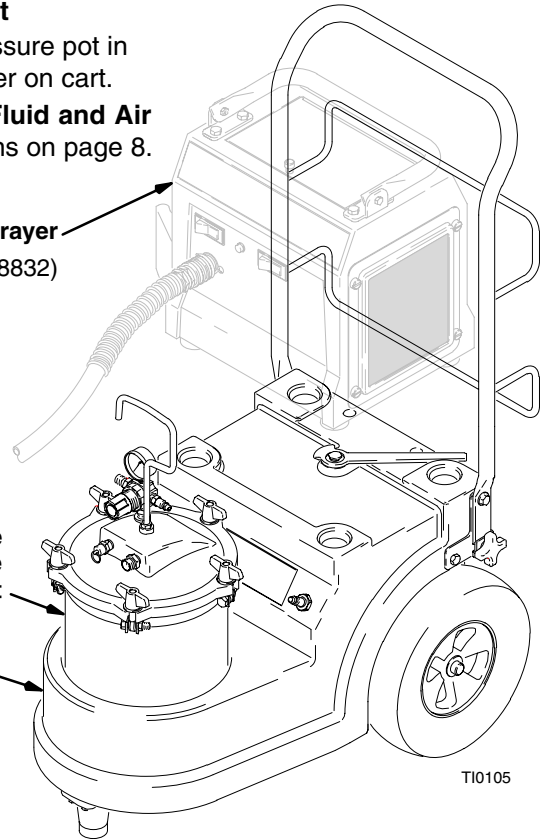

Compressor/Cart with 2 $\frac{1}{2}$ -gallon  
remote pressure pot

## Turbine Sprayer

1. Place turbine sprayer on cart.
2. Move latch on cart to the right to lock turbine sprayer.
3. Plug compressor/cart power cord into auxiliary electrical outlet on turbine sprayer or into a separate grounded electrical outlet.
4. Plug turbine sprayer into grounded electrical outlet.

**NOTE:** Extension cord must be 3-wire, 1.5 mm<sup>2</sup>, no longer than 15 m.

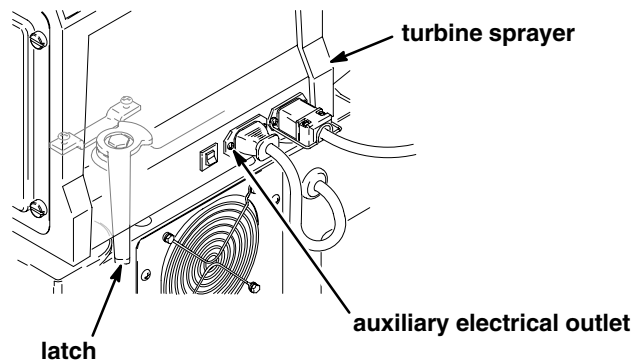

Fig. 3

# Setup

## Connect Fluid and Air Supply

See Fig. 4

- The HVLP compressor/cart provides the air supply for remote pressure pots.
- The circled letters in Fig. 4 indicate hose line connections.

1. Connect gun air supply hose (A) between turbine air outlet (B) and gun air inlet (C). DO NOT use wrench to tighten connections; hand tighten only.

**NOTE:** The GTS-4900 turbine uses a quick connector at the air outlet (B). A wrench is not required to connect the air hose (A).

2. If using spray gun cup (D):  
Connect cup to gun fluid inlet (E).

If using accessory remote pressure pot (F):  
Connect fluid supply hose (G) between remote pressure pot fluid outlet (H) and gun fluid inlet (E).  
Connect pressure pot air hose (J) between pressure pot air regulator inlet (K) and cart compressor air outlet (L).

## Connect to Electric Supply

See Turbine Sprayer in Fig. 3 on page 7.

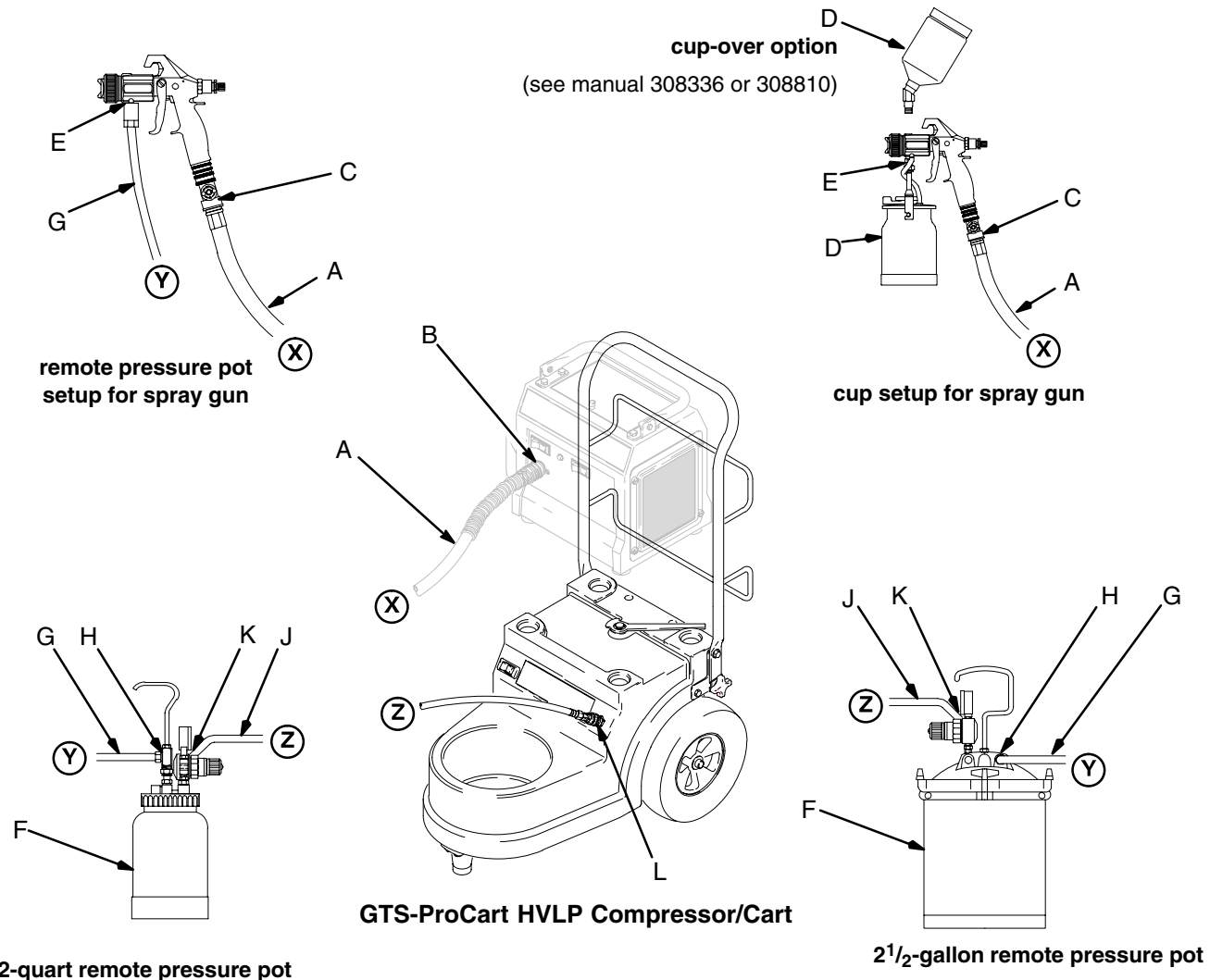

Fig. 4

7934A



# Setup

## Fill the Cup or Remote Pressure Pot

### Spray Gun Cup

#### **⚠ WARNING**

The spray gun cup is pressurized by the gun's air supply. To reduce the risk of serious injury from pressurized fluid or accidental spray from the gun, always turn off the air supply to the gun before you remove the spray gun cup.

Only fill the cup 3/4 full to help keep the air pressure tube clean, then install the cover. The under-cup cover has a latch (H) to secure it to the cup. The over-cup has a ring with notches (J) that secures the cup hood in place when locked in place on the cup.

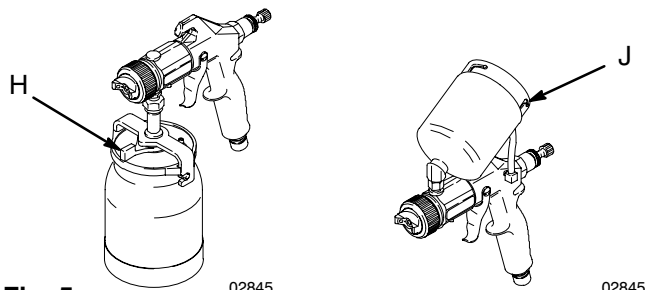

Fig. 5

### Accessory Remote Pressure Pot

#### **⚠ WARNING**

Accessory remote pressure pots remain pressurized until pressure is manually relieved. To reduce the risk of serious injury from pressurized fluid or accidental spray from the gun, always relieve pressure in the pressure pot before you loosen or remove the cover.

1. Relieve remote pot pressure as follows:
  - a. Turn off air supply to pressure pot. See Fig. 6.
  - b. 2<sup>1</sup>/<sub>2</sub>-gallon remote pressure pot:  
Pull pressure relief valve ring (206c) until pressure is completely relieved.  
2-quart remote pressure pot:  
Turn **out** pressure relief knob (113) one turn.  
Wait until pressure is completely relieved before you remove cover. Close knob.

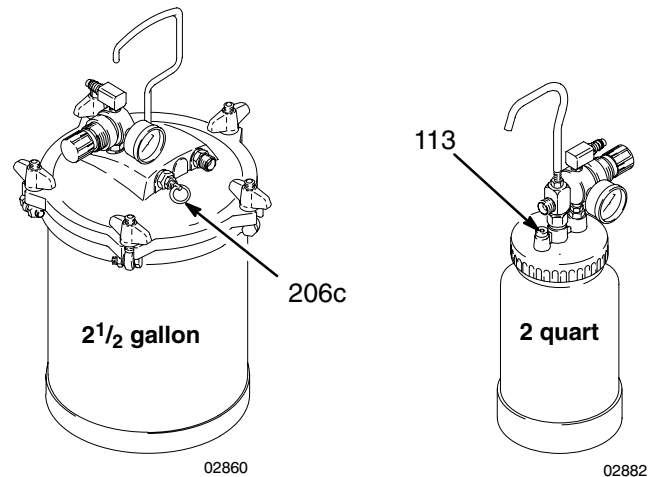

Fig. 6

2. Remove pressure pot cover, and fill. Secure cover.

**NOTE:** 2-quart remote pressure pot only:  
Lightly coat the cover threads with petroleum jelly.

#### **⚠ CAUTION**

If the 2-quart remote pressure pot is accidentally tipped over or held at too great of an angle, fluid may leak into the air regulator and cause damage. Take precautions to avoid this. If fluid does get into the regulator, clean it immediately.

#### **⚠ CAUTION**

Do not tighten the pressure pot cover more than hand-tight. Excessive tightening may damage the cover gasket.

# Setup

## Prepare the Surface to be Sprayed

To achieve proper adhesion, make sure the surface to be sprayed is completely clean.

## Operating the Compressor

### **WARNING**

Sparking can be expected in the normal operation of the motor. Sparks could ignite fumes from flammable liquid, dust particles, and other flammable substances in the spray area and cause serious injury and property damage.

Follow the precautions below:

- When flammable liquid is sprayed or used for flushing or cleaning equipment, the compressor must be placed at least 20 feet (6.1 m) away from areas where hazardous concentrations of flammable vapors are likely to occur.
- Use additional air hose if necessary to ensure that the compressor is operated in a clean, dry, well-ventilated area.
- Never place the compressor inside a spray booth! Use this equipment outdoors or in extremely well-ventilated areas.
- Avoid all ignition sources such as static electricity from plastic drop cloths, open flames such as pilot lights, hot objects such as cigarettes, and arcs from connecting or disconnecting power cords or from turning light switches on and off. Extinguish or remove all sources of ignition.

1. Turn the compressor on a few minutes before you start spraying to allow warm-up time.

**NOTE:** When the compressor is not in use for an extended period of time, turn it off. The compressor does not shut off automatically.

2. Be sure the compressor filter is clean before operating. See page 12 for instructions on checking and cleaning the filter.

**NOTE:** To adjust the spray pattern, see turbine gun manual 308336.

## Cold Weather Operation

The HVLP compressor/cart uses a diaphragm compressor. A new diaphragm may be stiff in cold weather. If cold enough, the diaphragm is too stiff to allow the compressor motor to start (the unit hums). If this occurs, follow these steps:

1. Turn turbine and compressor OFF.
2. Unplug turbine from power source.
3. Remove filter. Clean or replace if dirty.
4. Spin cooling fan on compressor for a few revolutions.
5. Reassemble filter.
6. Plug in turbine.
7. Turn turbine and compressor ON. Repeat procedure if necessary.

# Shutdown

## Pressure Relief Procedure

### WARNING

#### PRESSURIZED EQUIPMENT HAZARD

The equipment stays pressurized until pressure is manually relieved. To reduce the risk of a serious injury from pressurized fluid, accidental spray from the gun, or splashing fluid, follow the **Pressure Relief Procedure** whenever you

- Are instructed to relieve the pressure
- Stop spraying
- Check or service any of the system equipment
- Install or clean the fluid nozzles

1. Turn off air supply to gun.
2. Turn off turbine sprayer.

### WARNING

The turbine hose outlet may be hot. Carefully check the hose end before you remove the hose.

3. If using remote pressure pot, relieve pressure by following these steps:
  - a. Turn off air supply to pressure pot.
  - b. 2<sup>1</sup>/<sub>2</sub>-gallon remote pressure pot:  
Pull pressure relief valve ring (206c) until pressure is completely relieved.  
  
2-quart remote pressure pot:  
Turn **out** pressure relief knob (113) about one turn. Wait until pressure is completely relieved before you remove cover. Close knob. See Fig. 7.

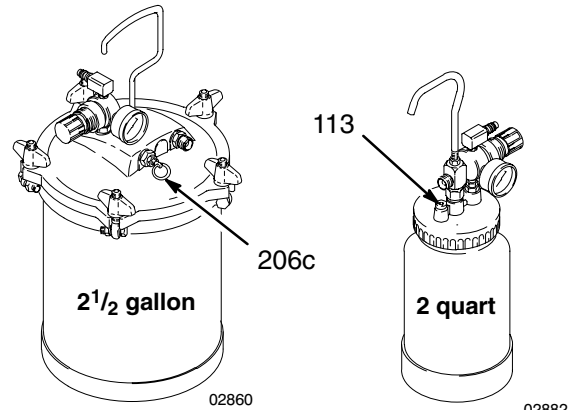

Fig. 7

**NOTE:** Elevate spray gun and pull trigger. This will allow fluid in fluid hose to drain back into remote pressure pot.

4. If using a spray gun cup:  
Unlatch cup cover, and loosen or remove cup from cover to relieve cup pressure.
5. Clean spray gun and cup as instructed in turbine gun manual 308336 or 308810.

# Maintenance

## Daily

Check the cart daily for cleanliness.

The compressor system is lifetime lubricated. The only maintenance required is filter cleaning and replacement.

The compressor filter must be clean at all times to provide sufficient air flow to cool the motor and pressurized air to the remote pressure pot. Check the filter daily. Clean or replace as necessary.

### To service the compressor filter

1. Turn off and unplug compressor.
2. Pinch filter (A) and remove by hand. See Fig. 8.
3. Clean or replace filter as follows:
  - a. Brush accumulated paint and dirt from surface of foam filter.
  - b. Rinse filter in water with mild detergent. Blow dry.
  - c. Replace filter if paint is caked on.

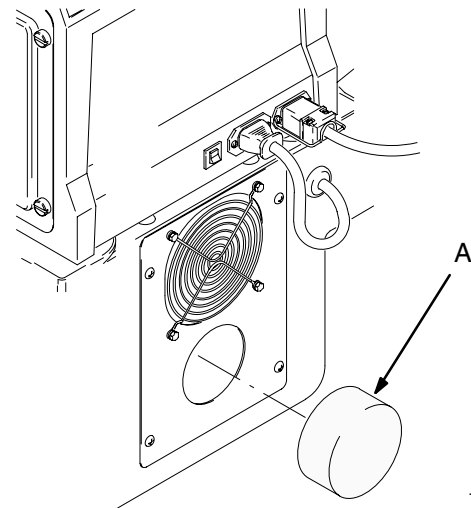

Fig. 8

TI0100A

## Weekly

Check hoses for cracks, leaks, and holes. Replace as necessary.

### WARNING

To avoid damage to the compressor and possible electric shock, never install a damp filter in the compressor.

### CAUTION

Dust and dirt can accumulate during use and cause equipment damage. Do not operate the compressor without the filter installed.

# Troubleshooting

| PROBLEM                 | CAUSE  | SOLUTION  |
|-------------------------|--|---|
| No fluid delivery       | No material, no remote container pressurization, hose or pickup tube clogged | Check container for material.   |
|                         |  | Check for leaks at the container gasket (2-quart pressure pot cover or 2 <sup>1</sup> / <sub>2</sub> -gallon pressure pot wing nuts). Tighten wing nuts if loose. |
|                         |  | Check for air flow from male quick disconnect at compressor outlet (approx. 1/4 CFM).   |
|                         |  | Turn pressure regulator clockwise. Look for pressure on gauge. (If no pressure on gauge, check air line and fittings).  |
|                         |  | Check hole in 2 <sup>1</sup> / <sub>2</sub> -gallon pressure pot cover under regulator or in 2-quart pressure pot cover at needle valve. Clean if necessary.      |
|                         |  | Check for obstructions or kinks in hoses and fittings.  |
|                         |  | Check if fluid pickup tube is unplugged. Tighten.   |
|                         |  | Blow out and clear material hose.   |
| Compressor not starting | Cold weather operation   | See <b>Cold Weather Operation</b> on page 10.   |

# Repair

## ⚠ WARNING

Turn off turbine and unplug power for the following procedures.

### Compressor/Cart Switch Replacement

See Fig. 9 and **Parts Drawing** on page 16.

1. To remove compressor power switch (28), wedge large flat blade screwdriver between top of switch and cart face plate.
2. Push down firmly on switch. Pry switch out far enough so two top locking tabs (A) are visible.
3. While maintaining outward pressure on switch, push down on two locking tabs with small flat-blade screwdriver until they release and switch pops out.
4. Disconnect the two wires, and remove switch.
5. Reinstall by connecting wires to new switch. Snap switch into place.

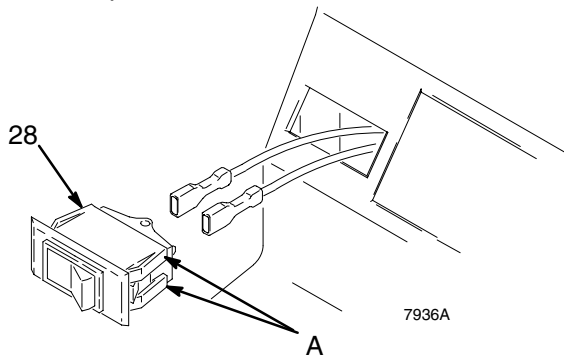

Fig. 9

### Power Cord Replacement

See **Parts Drawing** on page 16.

1. Remove four cart grill plate screws (23), and remove cart filter (9). Clean or replace filter as necessary.
2. Replace power cord (29).
3. Reinstall cart filter.

### Compressor Replacement

See Fig. 10, and **Parts Drawing** on page 16.

1. Remove four cart grill plate screws (23). Remove cart filter (9) and compressor duct (10). Clean or replace filter as necessary.
2. Remove air hose (12) from compressor.
3. Remove compressor mounting screws (11).
4. Disconnect motor wires, and remove compressor.
5. Install new compressor, and connect motor wires.
6. Reinstall hose on compressor.
7. Reinstall compressor duct and cart filter.

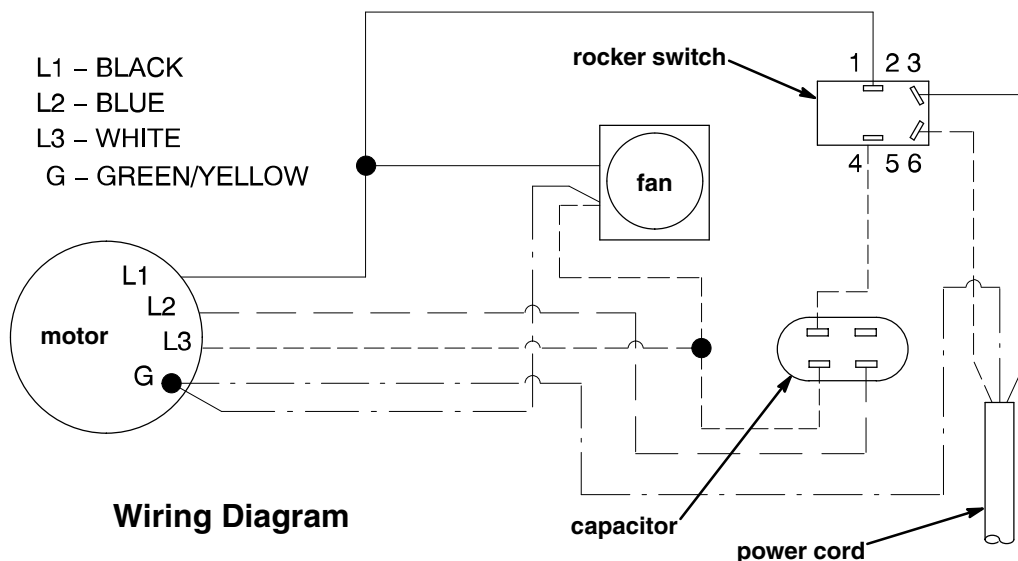

Fig. 10

# Accessories

| Fluid Set (FS)/Spray Gun |      |          |
|--------------------------|------|----------|
| FS                       | Gun  | Part No. |
| 3                        | 960P | 240773   |
| 3                        | 980P | 240103   |

| Standard Turbine Air Hose<br>Black (B) or Grey (G) |          |
|--|----------|
| Length (ft)  | Part No. |
| 20 (B)   | 240058*  |
| 40 (B)   | 240283   |
| 30 (G)   | 240059** |
| 40 (G)   | 240060   |
| 50 (G)   | 240061   |
| 60 (G)   | 240062   |

\* Standard on GTS-2500  
\*\* Standard on GTS-3800 and GTS-4900

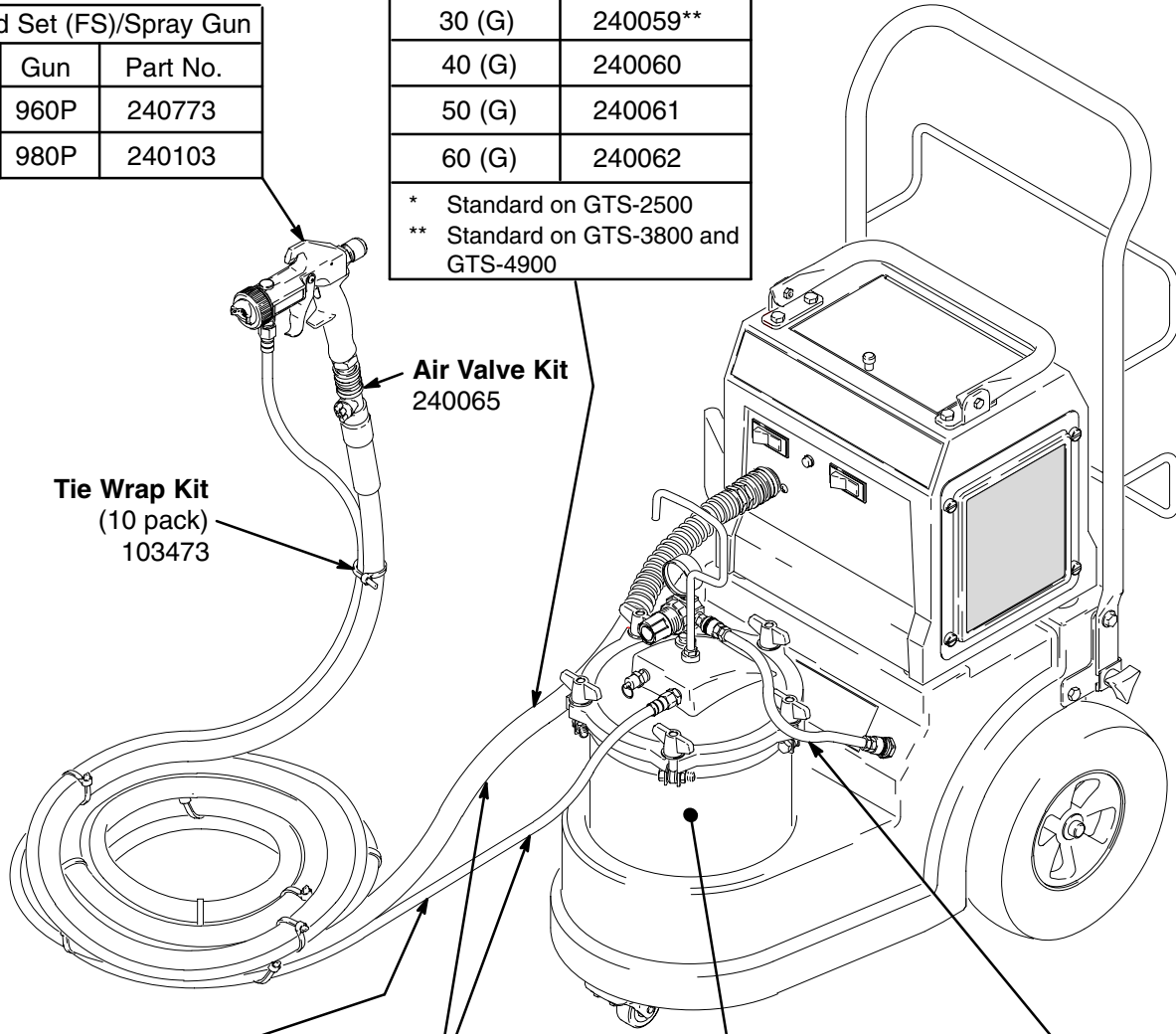

8483A

| Material Hose* |          |
|----------------|----------|
| Length (ft)    | Part No. |
| 20             | 240475   |
| 30             | 240476   |
| 40             | 240477   |
| 50             | 240478   |
| 60             | 240479   |

| Air & Material Hose |          |
|---------------------|----------|
| Length (ft)         | Part No. |
| 30                  | 240064   |
| 60                  | 240079   |

| Pressure Pot            |        |
|-------------------------|--------|
| Standard                | M70604 |
| PTFE <sup>®</sup> lined | 240045 |

| Compressor Air Hose |             |          |
|---------------------|-------------|----------|
| Pot                 | Length (ft) | Part No. |
| 2 1/2 gal           | 2           | 240074   |
|                     | 30          | 240071   |
| 2 qt                | 40          | 240072   |
|                     | 50          | 240073   |
|                     | 60          | 240074   |

### Notes:

- See **GTS-HVLP Fine Finish Systems** brochure 300477 for all accessories.
- Non-Silicone Lubricant 111265 (4 oz) is available for fluid seals and wear areas.

\* Material hose coupler M70693 may be used to couple two material hoses together.

# Parts Drawing

GTS-ProCart HVLP Compressor/Cart  
Model 233059, Series A

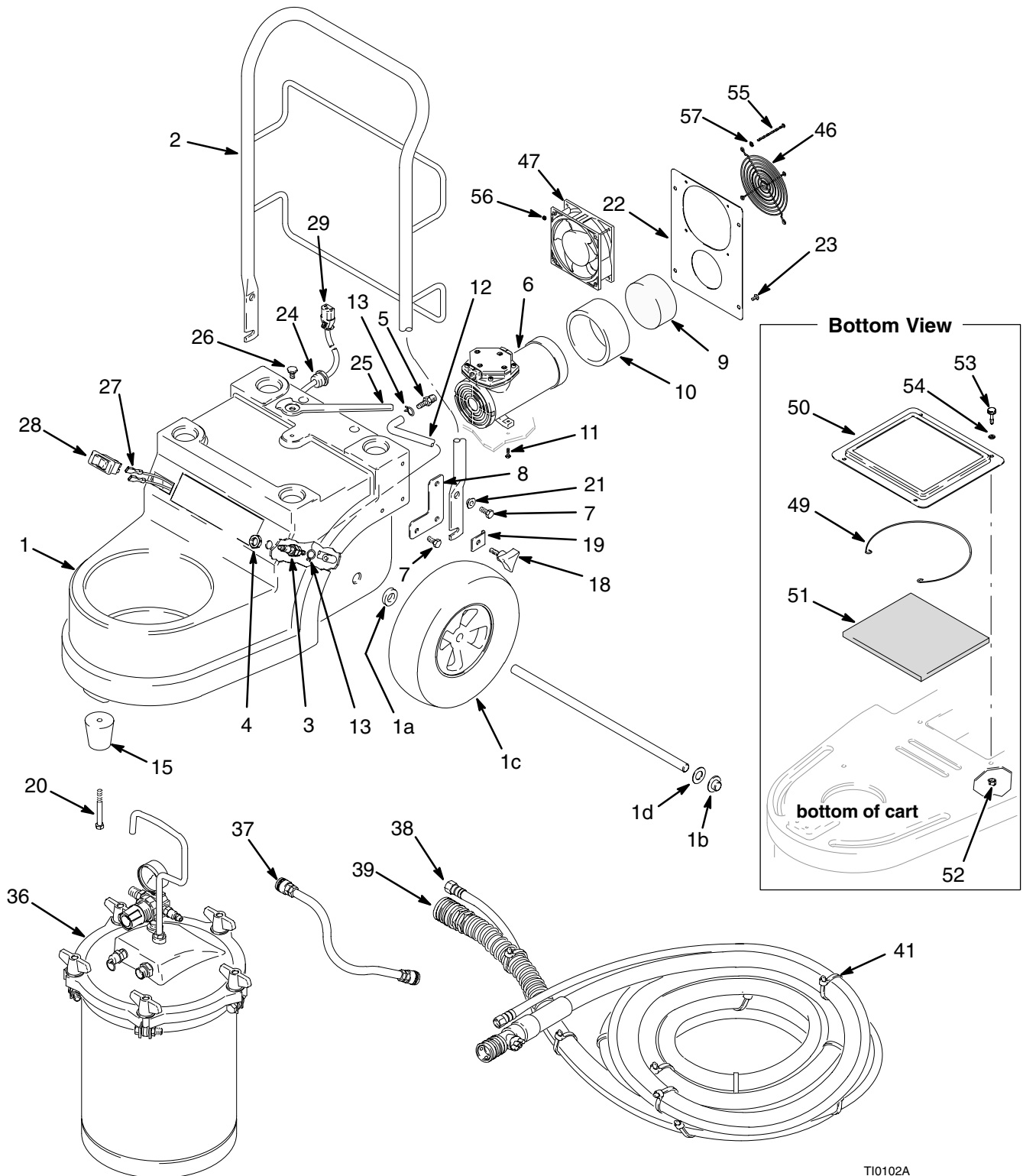

TI0102A



# Parts List

## GTS-ProCart HVLP Compressor/Cart Model 233059, Series A

| Ref No. | Part No. | Description                   | Qty | Ref No. | Part No. | Description   | Qty |
|---------|----------|-------------------------------|-----|---------|----------|---|-----|
| 1       | 243596   | HOUSING ASSY, cart            | 1   | 27      | 107262   | TERMINAL, insulated, female   | 3   |
| 1a      | 191824   | . WASHER, space               | 2   | 28      | 114293   | SWITCH, rocker, red   | 1   |
| 1b      | 113658   | . NUT, crest, hat             | 2   | 29      | 114299   | CORD SET, 0.6 m (24 in.)  | 1   |
| 1c      | 113647   | . WHEEL                       | 2   | 36      | M70604   | TANK, paint, 2 <sup>1</sup> / <sub>2</sub> gallon   | 1   |
| 1d      | 111841   | . WASHER, plain; 5/8 in.      | 2   | 37      | 240075   | HOSE, air, quick disconnect;<br>1/4 in. x 24 in.  | 1   |
| 2       | 240000   | HANDLE, cart                  | 1   | 38      | 240481   | HOSE, material, black;<br>3/8 in. x 30 ft   | 1   |
| 3       | 114047   | VALVE, check                  | 1   | 39      | 241335   | HOSE, turbine air, gray; 30 ft  | 1   |
| 4       | 178945   | NUT, hex                      | 1   | 41      | 103473   | TIE WRAP  | 10  |
| 5       | M70809   | FITTING, barbed               | 1   | 46      | 115836   | GUARD, finger   | 1   |
| 6       | 115833   | COMPRESSOR, 240V              | 1   | 47      | 115834   | FAN, cooling  | 1   |
| 7       | 105328   | SCREW, cap, hx hd             | 4   | 48      | 115835   | BRACKET, capacitor (Capacitor location<br>is shown in <b>Wiring Diagram</b> on page 14.)                                | 1   |
| 8       | 192798   | PLATE, handle                 | 2   | 49      | 196146   | RETAINER, spring  | 1   |
| 9†      | 195862   | FILTER, cart                  | 1   | 50      | 192778   | RETAINER, filter  | 1   |
| 10      | 192795   | DUCT, compressor              | 1   | 51      | 192792   | PRE-FILTER  | 1   |
| 11      | 112948   | SCREW, machine, pan hd        | 3   | 52      | 102040   | NUT, lock   | 4   |
| 12      | 192810   | HOSE, air, cart               | 1   | 53      | 100270   | SCREW, cap, hex head  | 4   |
| 13      | M71635   | CLAMP, hose                   | 2   | 54      | 100016   | WASHER, lock  | 4   |
| 15      | 193219   | SPACER, foot                  | 1   | 55      | 111705   | SCREW, machine, filister head   | 4   |
| 18      | 114270   | KNOB                          | 2   | 56      | 111280   | NUT, locking  | 5   |
| 19      | 192800   | RETAINER, handle              | 2   | 57      | 100079   | WASHER, spring-lock   | 4   |
| 20      | 107557   | SCREW, cap, hex hd            | 1   | 58      | 240255   | CONDUCTOR, electrical (Runs from<br>capacitor to Terminal 4 on rocker switch.<br>See <b>Wiring Diagram</b> on page 14.) | 1   |
| 21      | 192802   | SPACER, handle                | 2   |         | 115B315  | WIRE, ground (not shown)  | 1   |
| 22      | 196148   | PLATE, grill, cart            | 1   |         |          |   |     |
| 23      | 106084   | SCREW, mach, pan hd           | 4   |         |          |   |     |
| 24      | 114421   | CONNECTOR, cord strain relief | 1   |         |          |   |     |
| 25      | 192799   | HANDLE, latch                 | 1   |         |          |   |     |
| 26      | 192801   | SCREW, shoulder               | 1   |         |          |   |     |

† Cart filters are available in 3 packs. Order 240274.

## Specifications

|   |  |
|---|--|
| Power requirements  | 240V AC, 50/60 Hz, 1 Amp   |
| Power cord  | 1.5 mm <sup>2</sup> , 3 wire, 0.3 m (extension cord must be 3-wire, 1.5 mm <sup>2</sup> , no longer than 15 m) |
| CFM unrestricted  | 0.4 cfm  |
| HP  | 1/16 HP  |
| Maximum working pressure  | 15 psi (104 kPa, 1.0 bar)  |
| Maximum compressor hose length  | 60 ft (18 m)   |
| Wetted parts  |  |
| Material hose   | low-density polyethylene/rubber blend  |
| 2 <sup>1</sup> / <sub>2</sub> -gallon (9.5 liter) remote pressure pot | steel with solvent-resistant finish, EPDM gasket (standard)  |
| Compressor/Cart shipping weight (without packaging or hoses)          | 22 lb (10 kg)  |
| Sound levels per ISO 3744   |  |
| Sound power level   | 74.0 dB(A)   |
| Sound pressure level  | 70.0 dB(A)   |

PTFE<sup>®</sup> is a registered trademark

# Graco Standard Warranty

Graco warrants all equipment manufactured by Graco and bearing its name to be free from defects in material and workmanship on the date of sale by an authorized Graco distributor to the original purchaser for use. With the exception of any special, extended, or limited warranty published by Graco, Graco will, for a period of twelve months from the date of sale, repair or replace any part of the equipment determined by Graco to be defective. This warranty applies only when the equipment is installed, operated and maintained in accordance with Graco's written recommendations.

This warranty does not cover, and Graco shall not be liable for general wear and tear, or any malfunction, damage or wear caused by faulty installation, misapplication, abrasion, corrosion, inadequate or improper maintenance, negligence, accident, tampering, or substitution of non-Graco component parts. Nor shall Graco be liable for malfunction, damage or wear caused by the incompatibility of Graco equipment with structures, accessories, equipment or materials not supplied by Graco, or the improper design, manufacture, installation, operation or maintenance of structures, accessories, equipment or materials not supplied by Graco.

This warranty is conditioned upon the prepaid return of the equipment claimed to be defective to an authorized Graco distributor for verification of the claimed defect. If the claimed defect is verified, Graco will repair or replace free of charge any defective parts. The equipment will be returned to the original purchaser transportation prepaid. If inspection of the equipment does not disclose any defect in material or workmanship, repairs will be made at a reasonable charge, which charges may include the costs of parts, labor, and transportation.

**THIS WARRANTY IS EXCLUSIVE, AND IS IN LIEU OF ANY OTHER WARRANTIES, EXPRESS OR IMPLIED, INCLUDING BUT NOT LIMITED TO WARRANTY OF MERCHANTABILITY OR WARRANTY OF FITNESS FOR A PARTICULAR PURPOSE.**

Graco's sole obligation and buyer's sole remedy for any breach of warranty shall be as set forth above. The buyer agrees that no other remedy (including, but not limited to, incidental or consequential damages for lost profits, lost sales, injury to person or property, or any other incidental or consequential loss) shall be available. Any action for breach of warranty must be brought within two (2) years of the date of sale.

Graco makes no warranty, and disclaims all implied warranties of merchantability and fitness for a particular purpose in connection with accessories, equipment, materials or components sold but not manufactured by Graco. These items sold, but not manufactured by Graco (such as electric motors, switches, hose, etc.), are subject to the warranty, if any, of their manufacturer. Graco will provide purchaser with reasonable assistance in making any claim for breach of these warranties.

In no event will Graco be liable for indirect, incidental, special or consequential damages resulting from Graco supplying equipment hereunder, or the furnishing, performance, or use of any products or other goods sold hereto, whether due to a breach of contract, breach of warranty, the negligence of Graco, or otherwise.

## **FOR GRACO CANADA CUSTOMERS**

The parties acknowledge that they have required that the present document, as well as all documents, notices and legal proceedings entered into, given or instituted pursuant hereto or relating directly or indirectly hereto, be drawn up in English. Les parties reconnaissent avoir convenu que la rédaction du présente document sera en Anglais, ainsi que tous documents, avis et procédures judiciaires exécutés, donnés ou intentés à la suite de ou en rapport, directement ou indirectement, avec les procédures concernées.

## **ADDITIONAL WARRANTY COVERAGE**

Graco does provide extended warranty and wear warranty for products described in the "Graco Contractor Equipment Warranty Program".

# Graco Phone Number

**TO PLACE AN ORDER**, contact your Graco distributor, or call this number to identify the distributor closest to you:

**1-800-690-2894 Toll Free**

*All written and visual data contained in this document reflect the latest product information available at the time of publication.  
Graco reserves the right to make changes at any time without notice.*

**Sales Offices:** Minneapolis, Detroit

**Foreign Offices:** Belgium, Korea, Hong Kong, Japan

**GRACO INC. P.O. BOX 1441 MINNEAPOLIS, MN 55440-1441**

**[www.graco.com](http://www.graco.com)**

PRINTED IN USA 309115 01/2000, Revised 09/2003