



Read and keep for reference. For detailed instructions and warnings, see manual 309300.

## Software Upgrade Kit 244839

For upgrading ProBatch™ main PCB board software



To avoid damage, keep main PCB chip in its original packaging until you are ready to use it. Ground yourself with the wrist strap before handling circuit board components.

Kit includes:

Description	Qty.
Main PCB Chip with software update	1
Chip Extractor Tool	1
Grounding Wrist Strap	1

### Replacing Main PCB Chip



To reduce the risk of fire, explosion or electric shock:

- ProBatch controller must only be installed and serviced by a qualified electrician.
- Turn off ProBatch power switch and disconnect electrical power supply before servicing equipment.

1. Turn off ProBatch power switch.
2. Remove control box cover (A). See Manual 309300 and refer to **FIG. 2**.
3. Locate chip (B) on main circuit board. See **FIG. 1**.
4. Remove old PCB chip (B) with chip extractor provided.



The chip has three sharp corners and one chamfered corner. Orient the chip's chamfered corner toward the socket's chamfered corner. Incorrect installation can damage the chip or board.

5. Orient the new chip with the main PCB socket and lay it on the socket. With even pressure, snap the chip firmly into place. When properly installed, the top of the chip is flush with the top of the socket.
6. Reinstall control box cover.

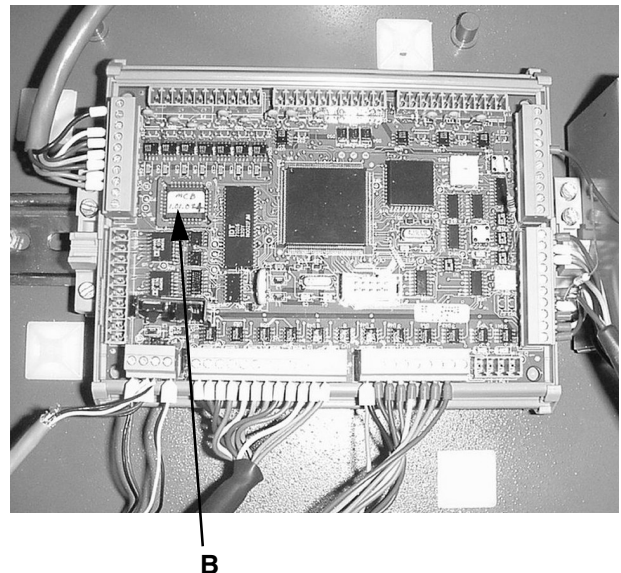

**FIG. 1**

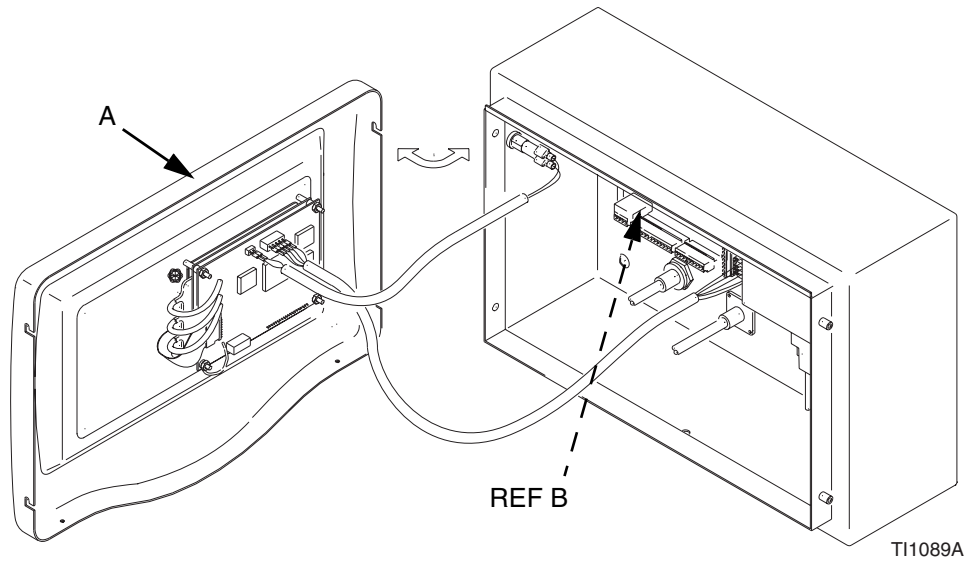

**FIG. 2**

---