

# Stainless Steel Air Motor Conversion Kits

309643D

## Conversion Kit 246450

For 1040 Pumps

## Conversion Kit 246451

For 1590 Pumps

## Conversion Kit 246452

For 2150 Pumps

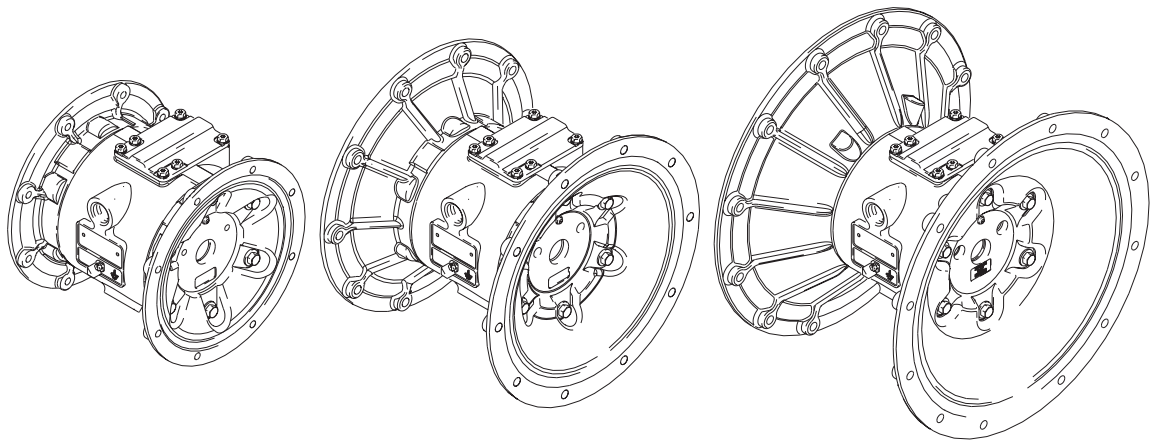

Model 246450

Model 246451

Model 246522

# Installation

## Pressure Relief Procedure

**WARNING**

**PRESSURIZED EQUIPMENT HAZARD**

The equipment stays pressurized until pressure is manually relieved. To reduce the risk of serious injury from pressurized fluid, accidental spray from the gun or splashing fluid, follow this procedure whenever you:

- Are instructed to relieve pressure
- Stop pumping
- Check, clean, or service any system equipment
- Install or clean fluid nozzles

1. Shut off the air to the pump
2. Open the dispensing valve, if used
3. Open the fluid drain valve to relieve all fluid pressure, having a container ready to catch the drainage

## Record Pump Information

Before you install the new stainless steel conversion kit, record the information from the existing pump in the box below. Refer to this information when you need to purchase repair kits or file a warranty claim.

PART NO.	SERIES	MADE IN
+	MAX GPM- l /MIN	+
Plate No. 290-045 Rev. C	WEIGHT LB - kg    MAX FLUID & AIR PSI-bar	

## Installation Tools Required

- Torque wrench
- 10 mm socket wrench (1040)
- 13 mm socket wrench (1590 & 2150)
- 15 mm socket wrench (metal fluid section)
- adjustable wrench (plastic fluid section)
- 19 mm open end wrench
- O-ring pick

## List of Parts in Kit

- Stainless steel air motor, with stainless steel air covers
- Small PTFE o-ring - used with center shaft, Qty 2
- Large PTFE o-ring - used with seats if applicable, Qty 4
- Thread locking compound (blue) - tube
- Lithium-based Grease - tube

# Metal Fluid Section Pumps

## Disassembly of Inlet and Outlet Manifolds

1. **Relieve the pressure**, see page 2. Disconnect all hoses.
2. Remove the pump from its mounting.
3. Remove the bolts (106) holding the outlet manifold (103) to the fluid covers (101). See FIG. 1.
4. Remove the o-rings (202, not used on some models), seats (201), and balls (301) from manifold (103).
5. Turn the pump over and remove the inlet manifold (102). Remove the o-rings (202, not used on some models), seats (201), and balls (301) from fluid covers (101).

- ⚠ 1 Apply medium-strength (blue) Loctite or equivalent to the threads, and torque to 120-150 in-lb (14-17 N.m).
- ⚠ 2 Arrow (A) must point toward outlet manifold (103).
- ⚠ 3 Beveled seating surface must face the ball (301).
- ⚠ 4 Not used on some models.

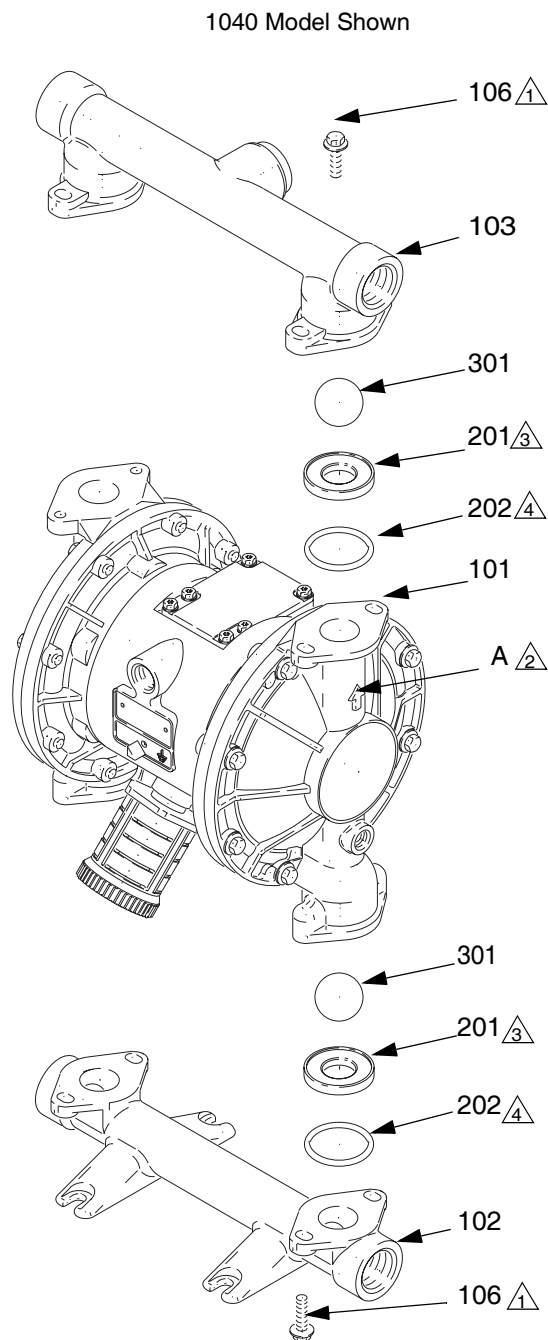

FIG. 1

### Disassembly of Fluid Covers

1. Remove the screws (106) holding the fluid covers (101) to the air covers (23). Pull the fluid covers (101) off the pump. See FIG. 2.
2. Loosen but do not remove the diaphragm shaft bolts (107) on both ends.
3. Unscrew one bolt from diaphragm shaft (24) and remove the o-ring (108), fluid side diaphragm plate (105), PTFE diaphragm (403, used on PTFE models only), diaphragm (401), and air side diaphragm plate (104). See FIG. 3
4. Pull the other diaphragm assembly and the diaphragm shaft (24) out of the center housing (1). Hold the shaft flats with a open end wrench, and remove the bolt (107) from the shaft. Disassemble the remaining diaphragm assembly.
5. Clean and check all parts for wear or damage. Replace parts as needed.

- ⚠ Apply medium-strength (blue) Loctite or equivalent to the threads, and torque:  
1040 models -120-150 in-lb (14-17 N.m.)  
1590/2150 models - 190-220 in-lb (22-25 N.m.)
- ⚠ Arrow (A) must point toward air valve (B).

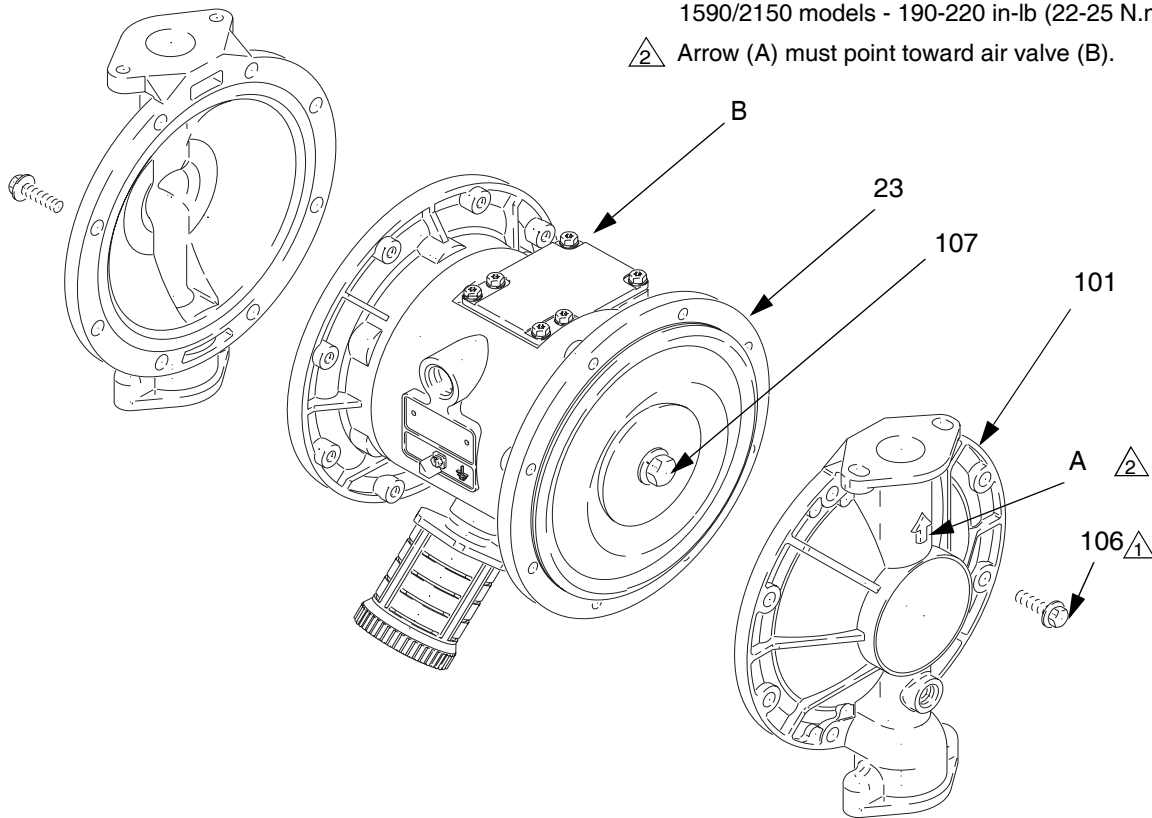
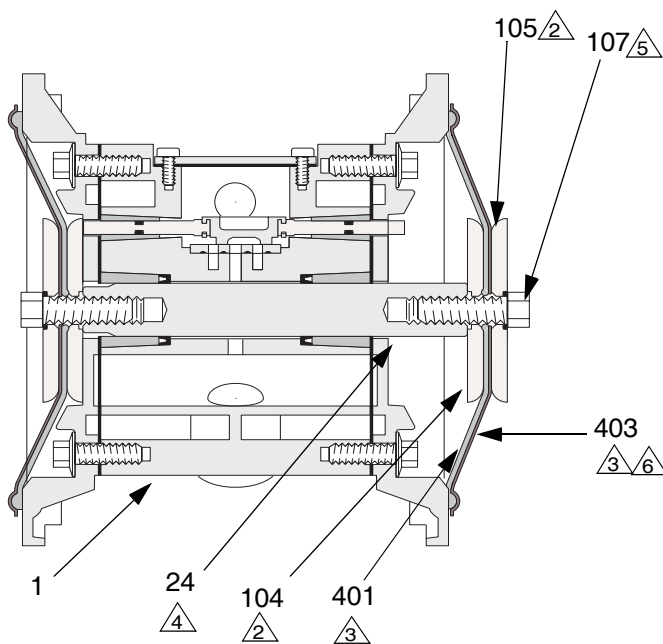
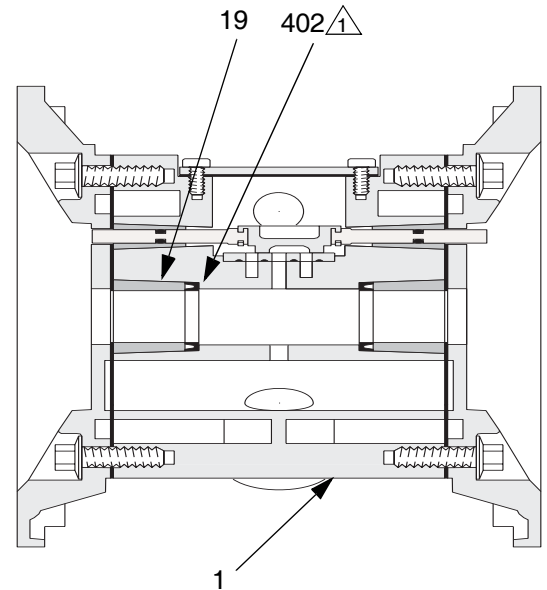

FIG. 2



Cutaway View, with Diaphragms in Place



Cutaway View, with Diaphragms Removed

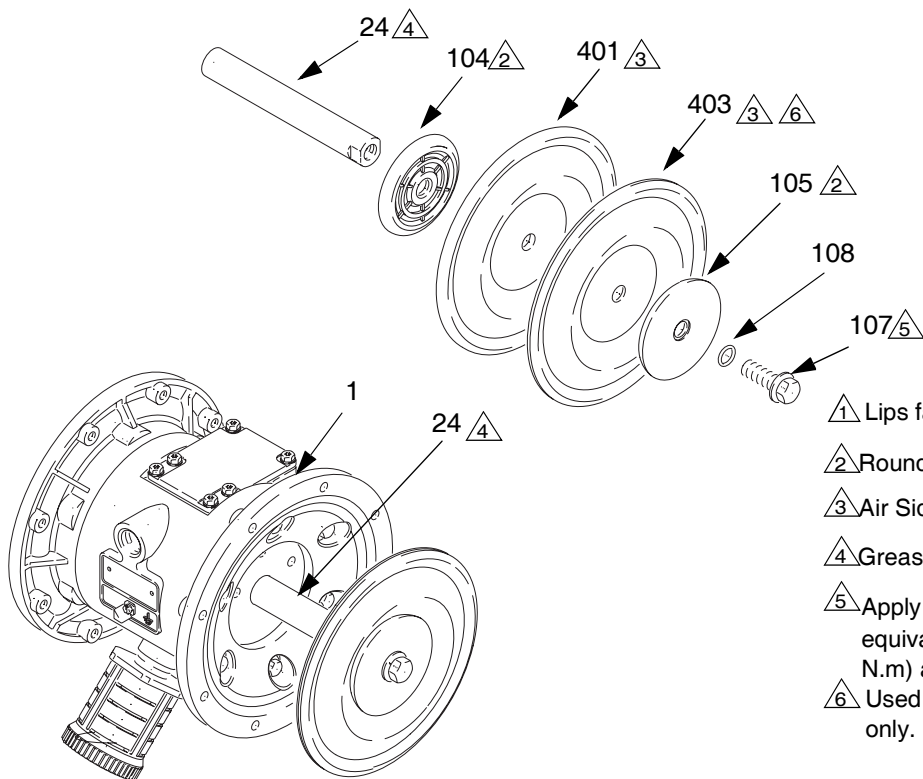

- ① Lips face out of housing (1).
- ② Rounded side faces diaphragm (401).
- ③ Air Side must face center housing (1).
- ④ Grease.
- ⑤ Apply medium-strength (blue) Loctite® or equivalent. Torque to 20-25 ft-lb (27-34 N.m) at 100 rpm maximum.
- ⑥ Used on pumps with PTFE diaphragms only.

FIG. 3

## Reassembly of Fluid Covers

1. Install the diaphragm assembly on one end of the shaft as follows:
  - a. Install new o-ring (108), provided with kit, on the shaft bolt (107).
  - b. Install the fluid side diaphragm plate (105) on the bolt so the rounded side faces the diaphragm (401).
  - c. On PTFE models only, install the PTFE diaphragm (403) with the side marked AIR SIDE facing the center housing (1).
  - d. Install the diaphragm (401) on the bolt with the side marked AIR SIDE facing the center housing (1).
  - e. Install the air side diaphragm plate (104) so the rounded side faces the diaphragm (401). This plate is used on all models, and is stamped with its part number.
  - f. Apply medium-strength (blue) Loctite or equivalent to the bolt (107) threads. Screw the bolt into the shaft (24) hand tight.
  - g. Inspect the wrench flats on the shaft (24) for burrs that could damage the air motor seals (402). Use a file to remove any burrs.
2. Grease the length and ends of diaphragm shaft (24), and slide it through the new Stainless Steel Plus housing (1).
3. Assemble the other diaphragm assembly to the shaft as explained in step 1.
4. Hold one shaft bolt (107) with a wrench and torque the other bolt to 20-25 ft-lb (27-34 N.m) at 100 rpm maximum.
5. Align the fluid covers (101) and the center housing (1) so the arrows (A) on the covers face the same direction as the air valve (B). Apply medium-strength (blue) Loctite or equivalent to the threads of the screws (106). Secure the covers with the screws handtight. See FIG. 2.
6. Torque the screws oppositely and evenly to:
  - 1040 models -120-150 in-lb (14-17 N.m.)
  - 1590/2150 models - 190-220 in-lb (22-25 N.m.)

## Reassembly of the Inlet and Outlet Manifolds

1. Reassemble in reverse order, following all notes in FIG. 1.
2. If o-rings (202) are used, replace with new ones to assure the pump will seal properly. Be sure the ball checks and manifolds are assembled exactly as shown. The arrows (A) on the fluid covers(101) must point toward the outlet manifold (103).

# Plastic Fluid Section Pumps

## Disassembly of Inlet and Outlet Manifolds

1. **Relieve the pressure**, page 2. Disconnect all hoses.
2. Remove the pump from its mounting.
3. Remove the bolts (106) holding the outlet manifold (103) to the fluid covers (101). See FIG. 4.
4. Remove the o-rings (202, not used on some models), seats (201), and balls (301) from manifold (103).
5. Turn the pump over and remove the inlet manifold (102). Remove the o-rings (202, not used on some models), seats (201), and balls (301) from fluid covers (101).

- ⚠️ 1 Torque to 80 to 90 in-lb (9 to 10 N.m)
- ⚠️ 2 Arrow (A) must point toward outlet manifold (103).
- ⚠️ 3 Not used on some models.
- ⚠️ 4 Beveled seating surface must face the ball (301).

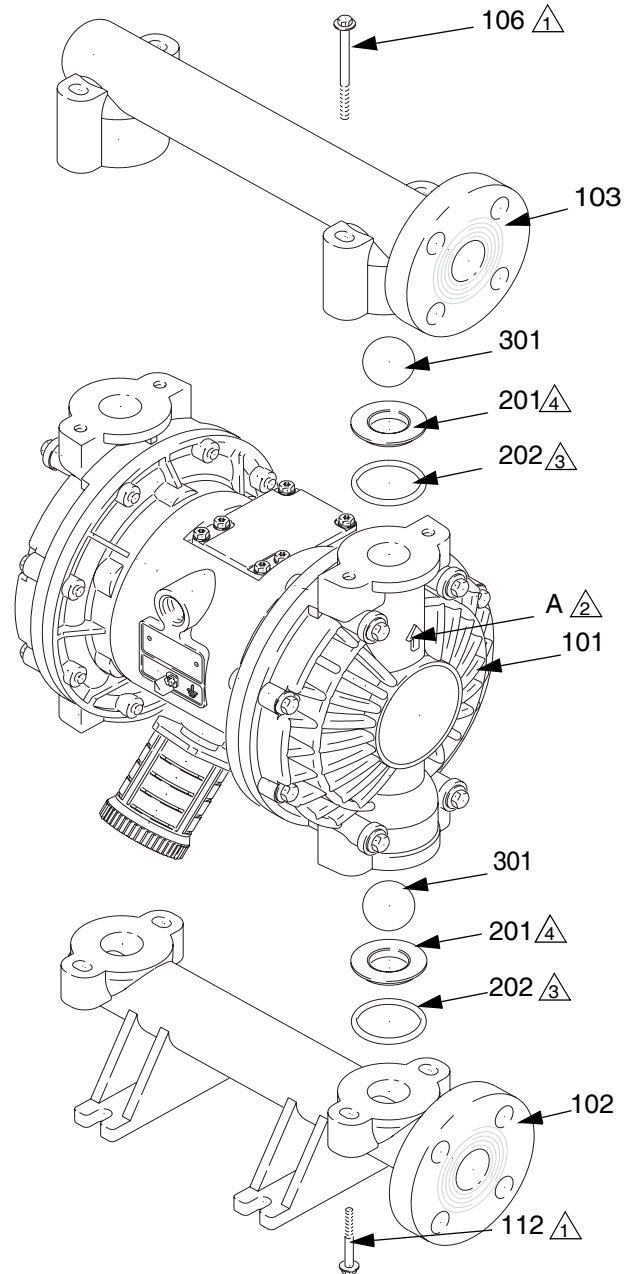

FIG. 4

### Disassembly of Fluid Covers

1. Remove the screws (106) and (112) holding the fluid covers (101) to the air covers (23). Pull the fluid covers (101) off the pump. See FIG. 5.
2. Unscrew one outer plate (105) from diaphragm shaft (24), diaphragm (401), and air side diaphragm plate (104). See FIG. 6.
3. Pull the other diaphragm assembly and the diaphragm shaft (24) out of the center housing (1). Hold the shaft flats with a open end wrench, and remove the other outer plate (105) from the shaft. Disassemble the remaining diaphragm assembly.
4. Clean and check all parts for wear or damage. Replace parts as needed.

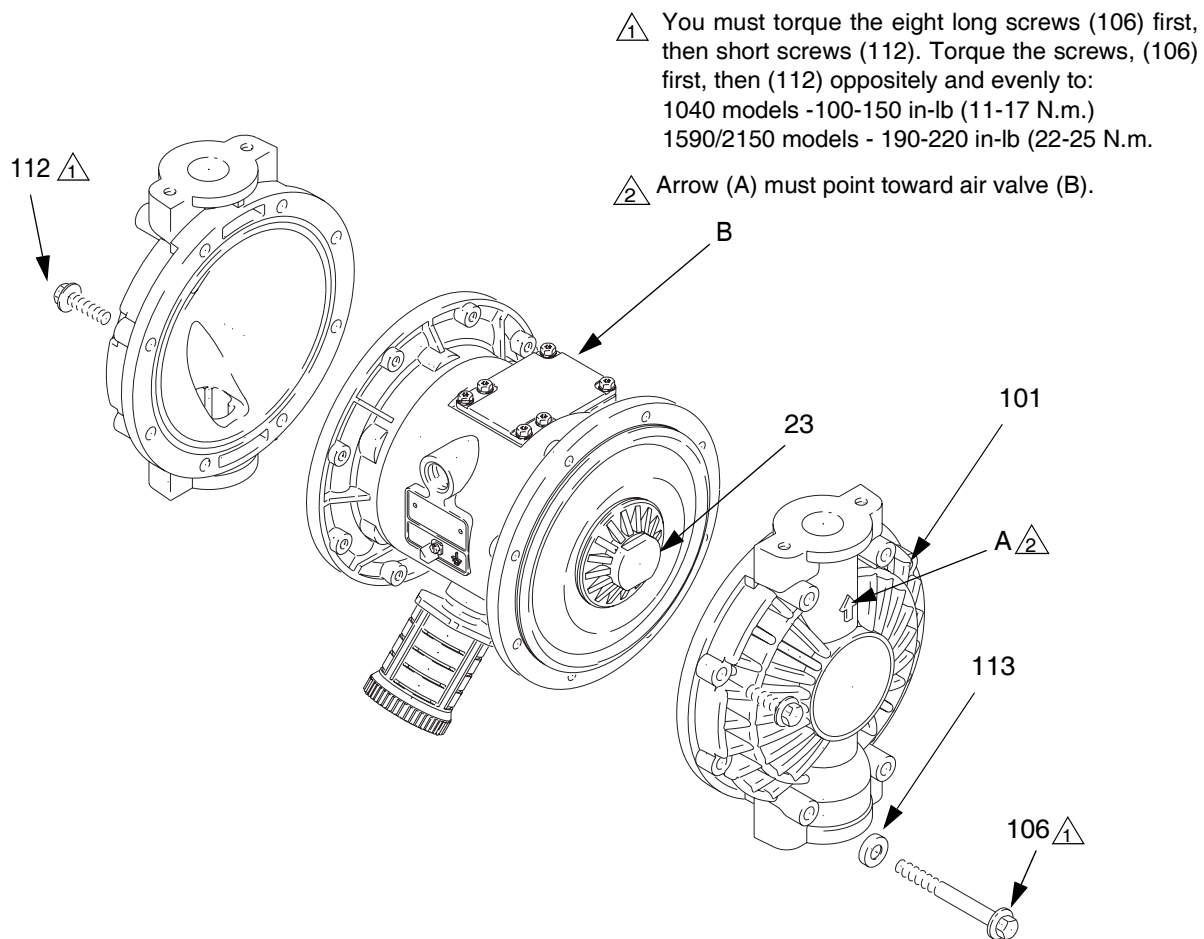

FIG. 5



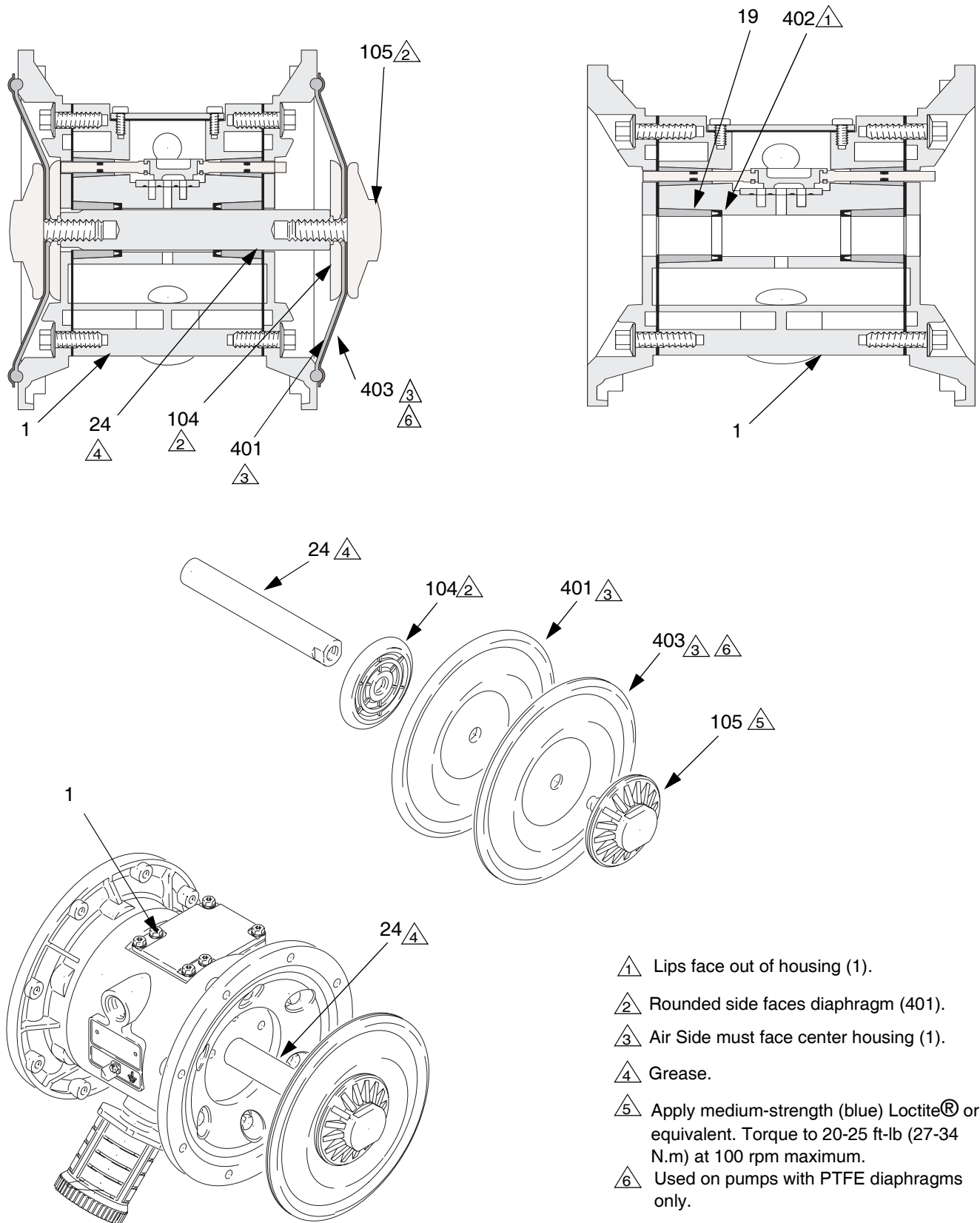

FIG. 6

## Reassembly of Fluid Covers

1. Inspect the wrench flats on the shaft (24) for burrs that could damage the air motor seals (402). Use a file to remove any burrs.
2. Grease the length and ends of diaphragm shaft (24), and slide it through the new Stainless Steel Plus housing (1).
3. Assemble the inner diaphragm plates (104), diaphragms (401), PTFE diaphragms (403, if present), and outer diaphragm plates (105) exactly as shown in Fig. 6. These parts **must** be assembled correctly.
4. Apply medium-strength (blue Loctite or equivalent to the threads of the fluid-side plate (105). Hold one of the outer plates (105) with a wrench, and torque the other outer plate to 20-25 ft-lb (27-34 N.m.) at 100 rpm maximum. **Do not over-torque.**
5. Align the fluid covers (101) and the center housing (1) so the arrows (A) on the covers face the same direction as the air valve (B). Apply

medium-strength (blue) Loctite or equivalent to the threads of the screws (106) and (112). Place the bolt caps (113) on the longer screws (106). Secure the covers with the screws handtight. See FIG. 2.

6. Torque the screws, (106) first, then (112) oppositely and evenly to:  
1040 models -100-150 in-lb (11-17 N.m.)  
1590/2150 models - 190-220 in-lb (22-25 N.m.)

## Reassembly of the Inlet and Outlet Manifolds

1. Reassemble in reverse order, following all notes in FIG. 4.
2. If o-rings (202) are used, replace with new ones to assure the pump will seal properly. Be sure the ball checks and manifolds are assembled exactly as shown. The arrows (A) on the fluid (101) must point toward the outlet manifold (103).



A series of horizontal lines spanning the width of the page, providing a template for writing or drawing.

# Graco Standard Husky Pump Warranty

Graco warrants all equipment referenced in this document which is manufactured by Graco and bearing its name to be free from defects in material and workmanship on the date of sale to the original purchaser for use. With the exception of any special, extended, or limited warranty published by Graco, Graco will, for a period of five years from the date of sale, repair or replace any part of the equipment determined by Graco to be defective. This warranty applies only when the equipment is installed, operated and maintained in accordance with Graco's written recommendations.

This warranty does not cover, and Graco shall not be liable for general wear and tear, or any malfunction, damage or wear caused by faulty installation, misapplication, abrasion, corrosion, inadequate or improper maintenance, negligence, accident, tampering, or substitution of non-Graco component parts. Nor shall Graco be liable for malfunction, damage or wear caused by the incompatibility of Graco equipment with structures, accessories, equipment or materials not supplied by Graco, or the improper design, manufacture, installation, operation or maintenance of structures, accessories, equipment or materials not supplied by Graco.

This warranty is conditioned upon the prepaid return of the equipment claimed to be defective to an authorized Graco distributor for verification of the claimed defect. If the claimed defect is verified, Graco will repair or replace free of charge any defective parts. The equipment will be returned to the original purchaser transportation prepaid. If inspection of the equipment does not disclose any defect in material or workmanship, repairs will be made at a reasonable charge, which charges may include the costs of parts, labor, and transportation.

**THIS WARRANTY IS EXCLUSIVE, AND IS IN LIEU OF ANY OTHER WARRANTIES, EXPRESS OR IMPLIED, INCLUDING BUT NOT LIMITED TO WARRANTY OF MERCHANTABILITY OR WARRANTY OF FITNESS FOR A PARTICULAR PURPOSE.**

Graco's sole obligation and buyer's sole remedy for any breach of warranty shall be as set forth above. The buyer agrees that no other remedy (including, but not limited to, incidental or consequential damages for lost profits, lost sales, injury to person or property, or any other incidental or consequential loss) shall be available. Any action for breach of warranty must be brought within six (6) years of the date of sale.

**GRACO MAKES NO WARRANTY, AND DISCLAIMS ALL IMPLIED WARRANTIES OF MERCHANTABILITY AND FITNESS FOR A PARTICULAR PURPOSE, IN CONNECTION WITH ACCESSORIES, EQUIPMENT, MATERIALS OR COMPONENTS SOLD BUT NOT MANUFACTURED BY GRACO.** These items sold, but not manufactured by Graco (such as electric motors, switches, hose, etc.), are subject to the warranty, if any, of their manufacturer. Graco will provide purchaser with reasonable assistance in making any claim for breach of these warranties.

In no event will Graco be liable for indirect, incidental, special or consequential damages resulting from Graco supplying equipment hereunder, or the furnishing, performance, or use of any products or other goods sold hereto, whether due to a breach of contract, breach of warranty, the negligence of Graco, or otherwise.

## **FOR GRACO CANADA CUSTOMERS**

The Parties acknowledge that they have required that the present document, as well as all documents, notices and legal proceedings entered into, given or instituted pursuant hereto or relating directly or indirectly hereto, be drawn up in English. Les parties reconnaissent avoir convenu que la rédaction du présente document sera en Anglais, ainsi que tous documents, avis et procédures judiciaires exécutés, donnés ou intentés, à la suite de ou en rapport, directement ou indirectement, avec les procédures concernées.

# Graco Information

For the latest information about Graco products, visit [www.graco.com](http://www.graco.com).

For patent information, see [www.graco.com/patents](http://www.graco.com/patents).

**TO PLACE AN ORDER**, contact your Graco distributor, or call this number to identify the distributor closest to you:  
**1-800-367-4023 Toll Free; 612-623-6921; 612-378-3505 Fax**

*All written and visual data contained in this document reflects the latest product information available at the time of publication.  
Graco reserves the right to make changes at any time without notice.*

Original instructions. This manual contains English. MM 309643

**Graco Headquarters:** Minneapolis  
**International Offices:** Belgium, China, Japan, Korea

**GRACO INC. AND SUBSIDIARIES • P.O. BOX 1441 • MINNEAPOLIS, MN 55440-1441**

Copyright 2002, Graco Inc. All Graco manufacturing locations are registered to ISO 9001

[www.graco.com](http://www.graco.com)

Revision D, April 2015