

Repair



TexSpray 1030 FC™

TexSpray Gun

309661 Rev. D

1000 psi (7.0 MPa, 70 bar) Maximum Working Pressure
140 psi (0.9 MPa, 9 bar) Maximum Air Working Pressure

Model 245872, Series B

Patents Pending

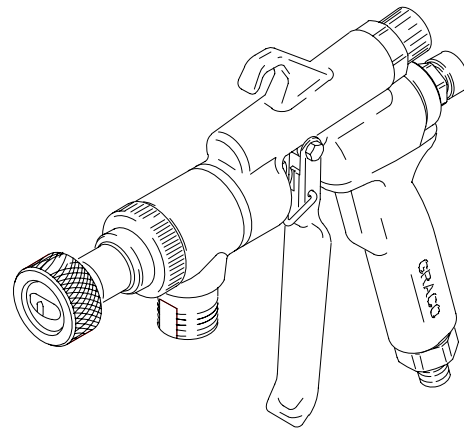

ti2313a



Read warnings and instructions.

Contents

Warnings	2
Installation	3
Operation	4
Air Cap and Nozzle Changes	5
Spray Disc and Nozzle Selection	6
Flushing	6
Service	7
Parts	8
Technical Data	9
Dimensions	9
Graco Phone Number	9
Graco Warranty	9

PROVEN QUALITY. LEADING TECHNOLOGY.



WARNING



INSTRUCTIONS

EQUIPMENT MISUSE HAZARD

Equipment misuse can cause the equipment to rupture, malfunction or start unexpectedly and result in serious injury.

- Do not exceed maximum working pressure of lowest rated system component.
- Do not alter or modify this equipment. Use only genuine Graco parts and accessories.
- Do not use hoses to pull equipment.
- Use fluids or solvents that are compatible with equipment wetted parts. See **Technical Data** section of all equipment manuals. Read manufacturer fluid and solvent warnings.
- Do not use 1,1,1-trichloroethane, methylene chloride, other halogenated hydrocarbon solvents or fluids containing such solvents in pressurized aluminum equipment. Such use could result in a chemical reaction, with the possibility of explosion.
- Do not use cementitious materials. Use simulated acoustic and wall texture materials.
- Wear eye and ear protection when spraying. Keep body parts away from front of gun.



RECOIL HAZARD

Due to the high pressure fluid emitted, a strong recoil action may occur when you trigger this gun. If you are unprepared, your hand could be forced back toward your body or you could lose your balance and fall, resulting in serious injury.

Component Description

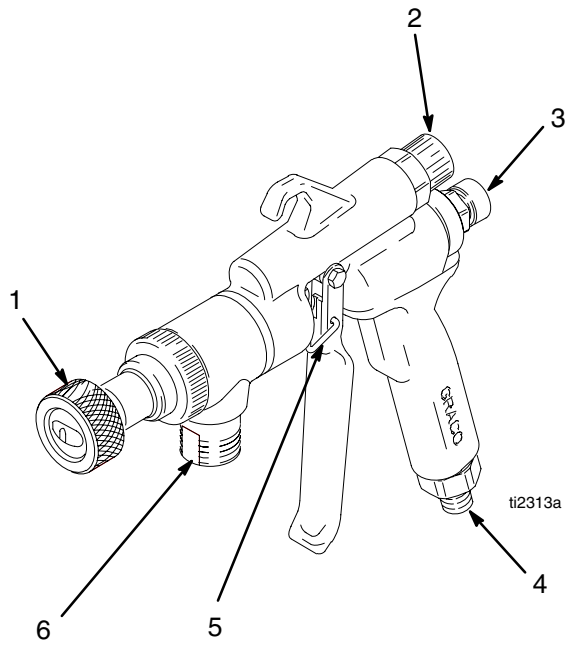

1	Air Nozzle
2	Air Control Knob
3	Material Control Knob
4	Air Inlet
5	Trigger Lock
6	Material Inlet

Installation



Eye Protection Hazard; page 2

1. Do **Pressure Relief Procedure**. See your system manual for correct procedure.
2. Connect air and material hoses to gun and tighten securely.
3. Install disc (2) on front of adapter (3) with retaining ring (1). Install nozzle (4) on front of gun with assembly (1, 2, 3).
4. Refer to TexSpray 1030 FC Operation Manual 309663 to start and prime sprayer.

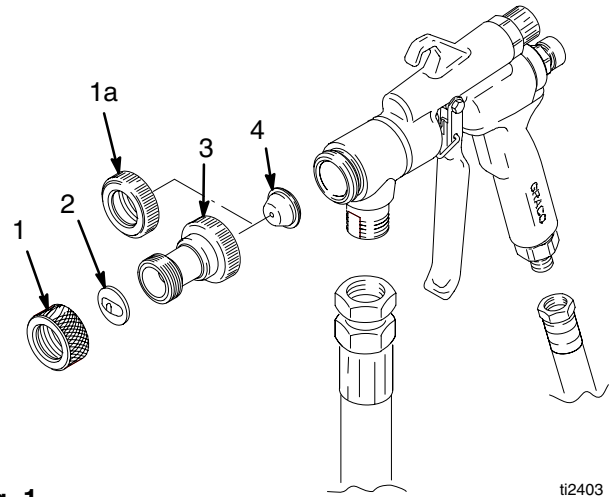

Fig. 1

ti2403

Operation

Pressure Relief Procedure

See your system manual for correct procedure.

How to Adjust Spray Pattern



Eye Protection Hazard; page 2

1. Turn air control knob (17) right fully to prevent air from mixing with fluid. Note that air exits rear of gun.
2. Hold gun 18 to 30 in. (0.5 to 1.0 m) from a test surface. Spray test pattern. Adjust air control knob (17) to obtain desired spray pattern.

TIP: More fluid flow = more air,
and less fluid = less air.

3. Adjust air regulator pressure or try another spray disc and nozzle combination if desired spray pattern is not achieved.

To prevent surge of unatomized material

1. Trigger gun fully.

If the gun is triggered partially, which only triggers the air portion of the system, the pump starts and pressurizes the hose. Then, when the triggering action is completed, there can be a surge of unatomized material.

2. Allow sprayer to completely depressurize after trigger is released.

Failure to allow sprayer to completely depressurize results in spraying unatomized material.

Air Cap and Nozzle Changes

Exterior or interior air caps may be used with nozzles and spray discs for different finishes, or with nozzles only.

1. Fig. 2. Select exterior or interior air cap.

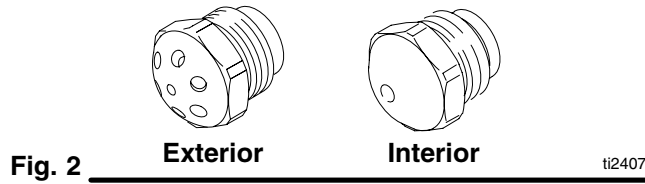

2. Fig. 3. Remove adapter (3) and nozzle (4) from gun.

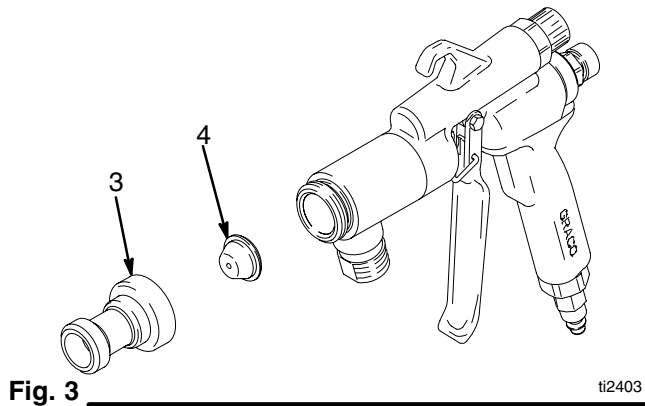

3. Fig. 4. Pull trigger (31). Insert a pin into hole (B) in gun needle (7) to hold gun needle in place.

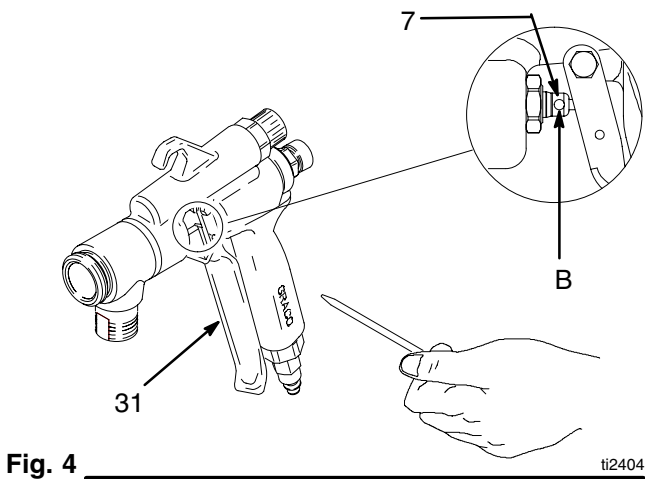

4. Fig. 5. Loosen and remove old air cap (5) with deep socket wrench.

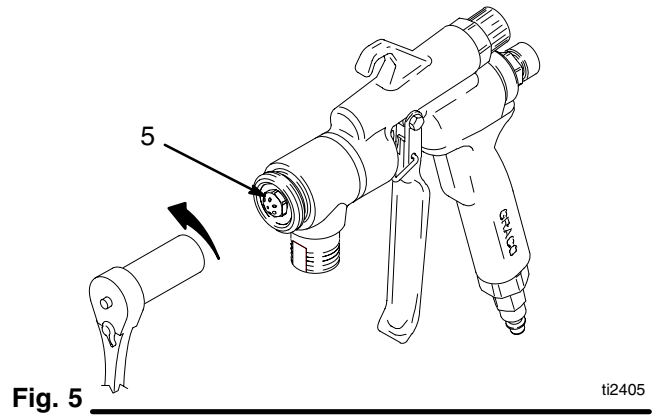

5. Fig. 6. Remove air valve (6) from old air cap (5).

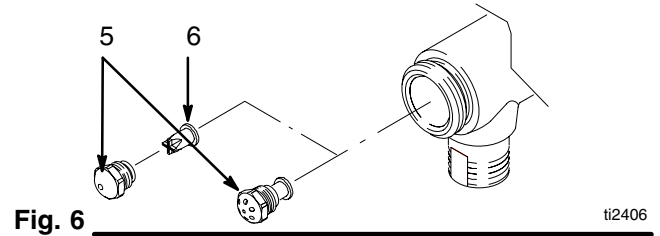

6. Install air valve (6) in selected air cap (5). Install both in gun. Tighten air cap 1/4 turn beyond finger tight.

7. Fig. 7. Install nozzle (4) selection with either retaining ring (1) or (1a), disc (2) and adapter (3). Grease nozzle threads to ease later removal. Hand tighten only to prevent damage to needle valve.

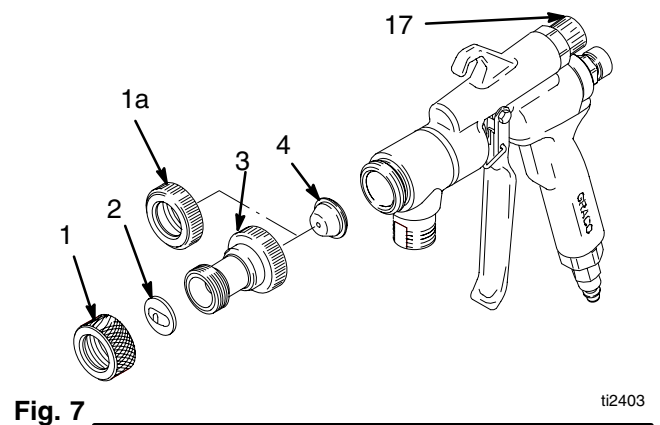

Spray Disc and Nozzle Selection

Fig. 7. Three spray discs (2) and five nozzles (4) are supplied with the sprayer. The nozzles are numbered 4, 6, 8, 10, and 12 which designate the orifice size in millimeters. These parts can be interchanged to produce a pattern suitable for each job.

For smaller droplet sizes reduce nozzle (4) and/or disc (2) size and increase gun atomizing air by turning the air control knob (17) counter-clockwise. For larger droplets, increase nozzle and/or disc size and reduce gun atomizing air by turning the air control knob clockwise.

Flushing

1. Prepare flushing fluid. Turn gun air control knob in (clockwise) completely to shut off air through needle. Start engine with sprayer flow control in **OFF**.
2. Turn flow control to **HIGH**.
3. Trigger gun into waste container until flushing fluid appears. Now direct flushing fluid into flushing pail. Secure gun trigger lock and circulate fluid until gun and hose are thoroughly flushed.
4. Reference **Air Cap and Nozzle Changes**. Remove and clean air cap (5) and air valve (6). Replace air valve if interior of air valve is full of fluid.
5. Release trigger – pressure relieves automatically.
6. Turn flow control to **PRIME**.
7. Circulate flushing fluid through pump, siphon hose and drain hose until well flushed.
8. To store sprayer, set sprayer flow control to **OFF** and turn engine switch **OFF**.

Reverse Material Head

The material inlet can be rotated 180°. This allows you to lay the material hose over your shoulder for ceiling applications.

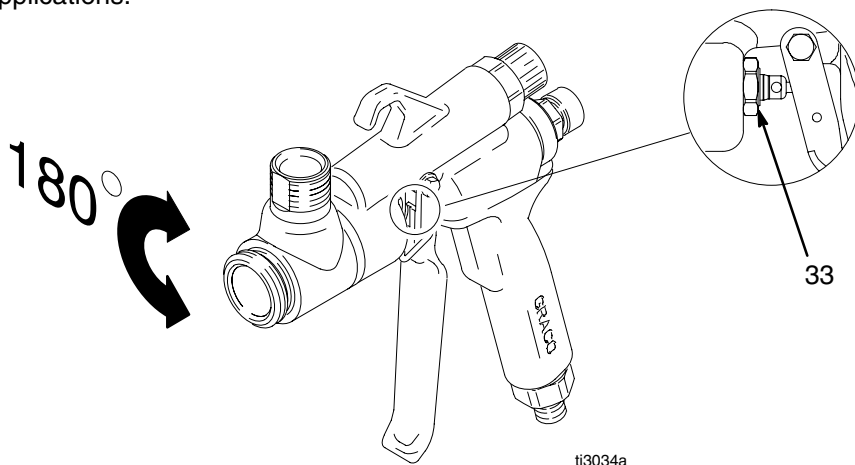

Fig. 8

1. Fig. 8. Loosen nut (33).
2. Pull gun head (8) and rotate 180°.
3. Push gun head (8) toward gun body (13) and tighten nut (33).

Service

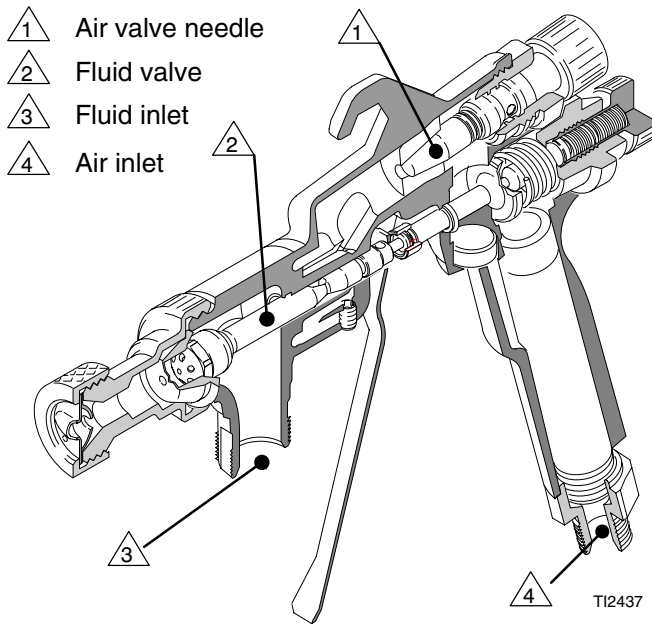

Fig. 9

NOTE: Refer to Parts Drawing, page 7 during service.

Air leaking around air valve needle when trigger is not activated

1. Follow **Pressure Relief Procedure**.
2. Remove pivot pin (12) and trigger (31).
3. Remove air valve housing (15), air valve needle (16) and o-ring (14).
4. Replace o-ring (14).
5. Lubricate o-ring (14). Assemble o-ring, air valve needle (16) and air valve housing (15).

No air flowing to nozzle. (Look for material buildup between air valve and air cap.)

1. Follow **Pressure Relief Procedure**.
2. Ensure air control knob (17) is turned out (counter clockwise).
3. Follow **Air Cap and Nozzle Change** instructions to remove air cap.

4. Clean and replace any damaged parts.

Air or fluid leakage at front of gun (Install 234229 gun rebuild kit components)

1. Follow **Pressure Relief Procedure**.

Remove and replace

1. Follow **Air Cap and Nozzle Change** instructions to remove air cap (5) and air valve (6).
2. Remove trigger (31) and nut (33).
3. Remove sleeve (11) from air valve (25)..
4. Remove gun head (8) from body (13).
5. Press on front stem (7) and slide to back of gun head.
6. Remove o-ring (34) from back of front stem (7).
7. Press rear of front stem (7) and slide out and remove from front of gun head (8).
8. Remove and replace o-ring (9) inside of gun head (8). Apply lubricant to o-ring.
9. Remove and replace o-ring (10) outside of gun head (8).

Install and assemble

1. Install new front stem (7) in gun head (8) and slide to back of gun head.
2. Install new o-ring (34) on back of front stem (7). Apply lubricant to o-ring.
3. Press front stem (7) forward and slide to front of gun head (8).
4. Install gun head (8) on body (13).
5. Place new sleeve (11) over end of air valve (25) with outside groove of sleeve toward back of gun.
6. Press front stem (7) into sleeve and Install trigger (31) and nut (33).
7. Follow **Air Cap and Nozzle Change** instructions to install air cap (5) and air valve (6).

Parts

Model 245872, Series B

Includes items 1 to 34

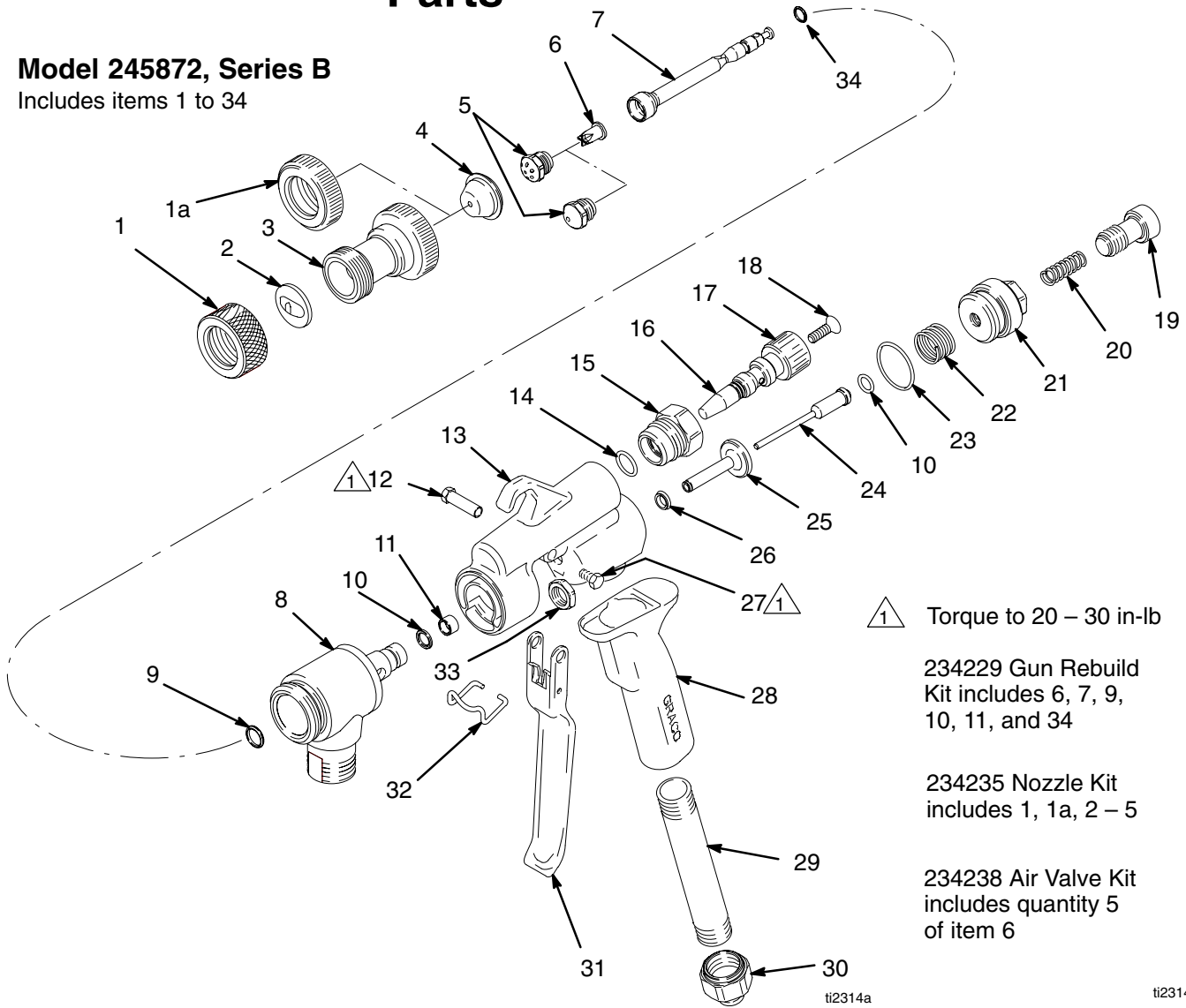

 Torque to 20 – 30 in-lb

234229 Gun Rebuild Kit includes 6, 7, 9, 10, 11, and 34

234235 Nozzle Kit includes 1, 1a, 2 – 5

234238 Air Valve Kit includes quantity 5 of item 6

ti2314a

ti2314a

Ref No.	Part No.	Description	Qty	Ref No.	Part No.	Description	Qty
1	188354	RETAINING NUT	1	13	287096	GUN BODY, includes 26	1
1a	15B042	RETAINING NUT	1	14	103610	O-RING	1
2		SPRAY DISCS (all sizes included)	1	15	15A952	AIR VALVE HOUSING	1
	235579	1/8 in. orifice	1	16	15A953	AIR VALVE NEEDLE	1
	235580	1/4 in. orifice	1	17	15B741	AIR CONTROL KNOB	1
	235581	3/8 in. orifice	1	18	111945	SCREW, cap, flat hd	1
3	15B189	ADAPTER	1	19	15A966	CONTROL KNOB	1
4		NOZZLES (all sizes included)	1	20	118425	SPRING	1
	15B038	4 mm	1	21	15A774	ADJUSTMENT HOUSING	1
	15B039	6 mm	1	22	15B920	SPRING	1
	15B040	8 mm	1	23	110066	O-RING	1
	15B503	10 mm	1	24	15A883	PUSHROD	1
	15B041	12 mm	1	25	243842	AIR VALVE	1
5		AIR CAP	1	26	15C226	U-CUP	1
	15A047	EXTERIOR	1	27	203953	LOCK SCREW, pivot pin	1
	15A896	INTERIOR	1	28	15B433	HANDLE	1
6	15B765	AIR VALVE	1	29	15B045	TUBE, handle	1
7	15A884	FRONT STEM	1	30	15B051	FITTING	1
8	15A771	GUN HEAD	1	31	15B472	TRIGGER	1
9	113137	O-RING	1	32	15B551	TRIGGER LOCK	1
10	112085	O-RING	2	33	15B476	NUT	1
11	15B309	SLEEVE	1	34	106560	O-RING	1
12	15C673	PIVOT PIN	1				
8	309661						

Technical Data

Maximum Air Working Pressure 140 psi (9 bar)
Air Requirements . . . 30 scfm (0.84 m³/min) Maximum
Fluid Inlet Size 3/4 npsm(m)
Air Inlet Size 3/8 npt(m)
Wetted Parts Aluminum, Stainless Steel,
Steel, Viton[®], nylon

Sound Data (gun only):
Sound Pressure Level 96dB(A)*
Sound Power Level 104dB(A)*

* Spraying simulated acoustical texture under typical conditions as specified by the material manufacturer.
Viton and Delrin are registered trademarks

Dimensions

Weight (dry, without packaging) 35 oz (1008 g)
Height 8.7 in. (221 mm)
Length 9.7 in. (246 mm)
Width 1.6 in. (41 mm)

Graco Phone Number

TO PLACE AN ORDER, contact your Graco distributor, or call **1-800-690-2894 Toll Free**, to identify the distributor closest to you:

Graco Warranty

Graco warrants all equipment manufactured by Graco and bearing its name to be free from defects in material and workmanship on the date of sale by an authorized Graco distributor to the original purchaser for use. With the exception of any special, extended, or limited warranty published by Graco, Graco will, for a period of twelve months from the date of sale, repair or replace any part of the equipment determined by Graco to be defective. This warranty applies only when the equipment is installed, operated and maintained in accordance with Graco's written recommendations.

This warranty does not cover, and Graco shall not be liable for general wear and tear, or any malfunction, damage or wear caused by faulty installation, misapplication, abrasion, corrosion, inadequate or improper maintenance, negligence, accident, tampering, or substitution of non-Graco component parts. Nor shall Graco be liable for malfunction, damage or wear caused by the incompatibility of Graco equipment with structures, accessories, equipment or materials not supplied by Graco, or the improper design, manufacture, installation, operation or maintenance of structures, accessories, equipment or materials not supplied by Graco.

This warranty is conditioned upon the prepaid return of the equipment claimed to be defective to an authorized Graco distributor for verification of the claimed defect. If the claimed defect is verified, Graco will repair or replace free of charge any defective parts. The equipment will be returned to the original purchaser transportation prepaid. If inspection of the equipment does not disclose any defect in material or workmanship, repairs will be made at a reasonable charge, which charges may include the costs of parts, labor, and transportation.

THIS WARRANTY IS EXCLUSIVE, AND IS IN LIEU OF ANY OTHER WARRANTIES, EXPRESS OR IMPLIED, INCLUDING BUT NOT LIMITED TO WARRANTY OF MERCHANTABILITY OR WARRANTY OF FITNESS FOR A PARTICULAR PURPOSE.

Graco's sole obligation and buyer's sole remedy for any breach of warranty shall be as set forth above. The buyer agrees that no other remedy (including, but not limited to, incidental or consequential damages for lost profits, lost sales, injury to person or property, or any other incidental or consequential loss) shall be available. Any action for breach of warranty must be brought within two (2) years of the date of sale.

Graco makes no warranty, and disclaims all implied warranties of merchantability and fitness for a particular purpose in connection with accessories, equipment, materials or components sold but not manufactured by Graco. These items sold, but not manufactured by Graco (such as electric motors, switches, hose, etc.), are subject to the warranty, if any, of their manufacturer. Graco will provide purchaser with reasonable assistance in making any claim for breach of these warranties.

In no event will Graco be liable for indirect, incidental, special or consequential damages resulting from Graco supplying equipment hereunder, or the furnishing, performance, or use of any products or other goods sold hereto, whether due to a breach of contract, breach of warranty, the negligence of Graco, or otherwise.

FOR GRACO CANADA CUSTOMERS

The parties acknowledge that they have required that the present document, as well as all documents, notices and legal proceedings entered into, given or instituted pursuant hereto or relating directly or indirectly hereto, be drawn up in English. Les parties reconnaissent avoir convenu que la rédaction du présente document sera en Anglais, ainsi que tous documents, avis et procédures judiciaires exécutés, donnés ou intentés à la suite de ou en rapport, directement ou indirectement, avec les procédures concernées.

ADDITIONAL WARRANTY COVERAGE

Graco does provide extended warranty and wear warranty for products described in the "Graco Contractor Equipment Warranty Program".

All written and visual data contained in this document reflects the latest product information available at the time of publication. Graco reserves the right to make changes at any time without notice.

Sales Offices: Minneapolis, Detroit
International Offices: Belgium, Korea, Hong Kong, Japan

GRACO INC. P.O. BOX 1441 MINNEAPOLIS, MN 55440-1441
<http://www.graco.com>