



Repair



Ultimate[®] Mx II 695/795/1095/1595[™] Airless Sprayers

309942 Rev. F

3300 psi (227 bar, 22.7 MPa) Maximum Working Pressure

Vac	Model	Standard/ Premium		
120 North America 	695	Standard	826048	826047
		Premium	826041	826040
	795	Standard		826049
		Premium		826042
	1095	Standard		826050
		Premium		826044
	1595	Standard		826054 826051*
		Premium		826053 826045*

* Not ETL Approved

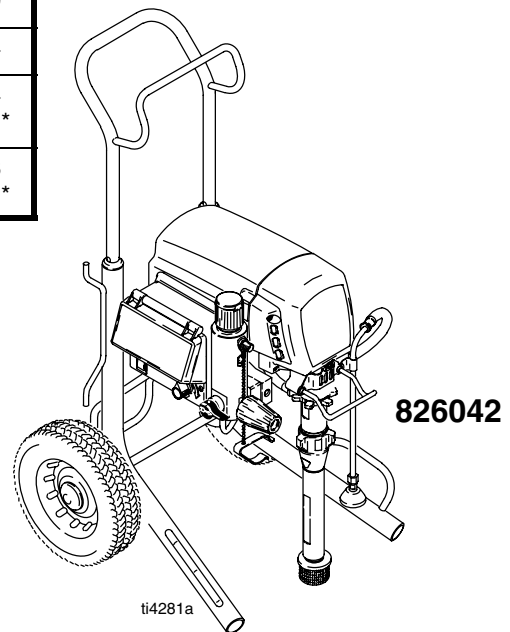

PROVEN QUALITY. LEADING TECHNOLOGY.

GRACO INC. P.O. BOX 1441 MINNEAPOLIS, MN 55440-1441





©COPYRIGHT 2004, GRACO INC.

Graco Inc. is registered to I.S. EN ISO 9001

Table of Contents

Component Function and Identification	4	Drive and Bearing Housing Replacement . .	12
General Repair Information	5	Motor Replacement	14
Grounding	5	Displacement Pump Replacement	16
Troubleshooting	6	3-D Wiring Diagram	17
Mechanical/Fluid Flow	6	Technical Data	18
Electrical	7	Dimensions	18
Pressure Control Repair	10	Graco Phone Number	18

WARNING

	<p>FIRE AND EXPLOSION HAZARD</p> <p>Flammable fumes, such as solvent and paint fumes, in work area can ignite or explode. To help prevent fire and explosion:</p> <ul style="list-style-type: none">• Use equipment only in well ventilated area.• Eliminate all ignition sources; such as pilot lights, cigarettes, portable electric lamps, and plastic drop cloths (potential static arc).• Keep work area free of debris, including solvent, rags and gasoline.• Do not plug or unplug power cords or turn lights on or off when flammable fumes are present.• Ground equipment and conductive objects in work area. See Grounding instructions.• Use only conductive hoses.• Hold gun firmly to side of grounded pail when triggering into pail.• If there is static sparking or you feel a shock, stop operation immediately. Do not use equipment until you identify and correct the problem.
	<p>SKIN INJECTION HAZARD</p> <p>High-pressure fluid from gun, hose leaks, or ruptured components will pierce skin. This may look like just a cut, but it is a serious injury that can result in amputation. Get immediate surgical treatment.</p> <ul style="list-style-type: none">• Do not point the gun at anyone or at any part of the body.• Do not put your hand over the spray tip.• Do not stop or deflect leaks with your hand, body, glove or rag.• Do not spray without tip guard and trigger guard installed.• Engage trigger lock when not spraying.• Follow the Pressure Relief Procedure on page 5 if the spray tip clogs and before cleaning, checking or servicing the equipment.
	<p>ELECTRIC SHOCK HAZARD</p> <p>Improper grounding, setup or usage of the system can cause electric shock.</p> <ul style="list-style-type: none">• Turn off and disconnect power cord before servicing equipment.• Use only grounded electrical outlets.• Use only 3-wire extension cords.• Ensure ground prongs are intact on sprayer and extension cords.
	<p>PERSONAL PROTECTIVE EQUIPMENT</p> <p>You must wear appropriate protective equipment when operating, servicing, or when in the operating area of the equipment to help protect you from serious injury, including eye injury, inhalation of toxic fumes, burns, and hearing loss. This equipment includes but is not limited to:</p> <ul style="list-style-type: none">• Protective eyewear• Clothing and respirator as recommended by the fluid and solvent manufacturer• Gloves• Hearing protection
	<p>PRESSURIZED ALUMINUM PARTS HAZARD</p> <p>Do not use 1,1,1-trichloroethane, methylene chloride, other halogenated hydrocarbon solvents or fluids containing such solvents in pressurized aluminum equipment. Such use can cause serious chemical reaction and equipment rupture, and result in death, serious injury, and property damage.</p>

Component Identification and Function

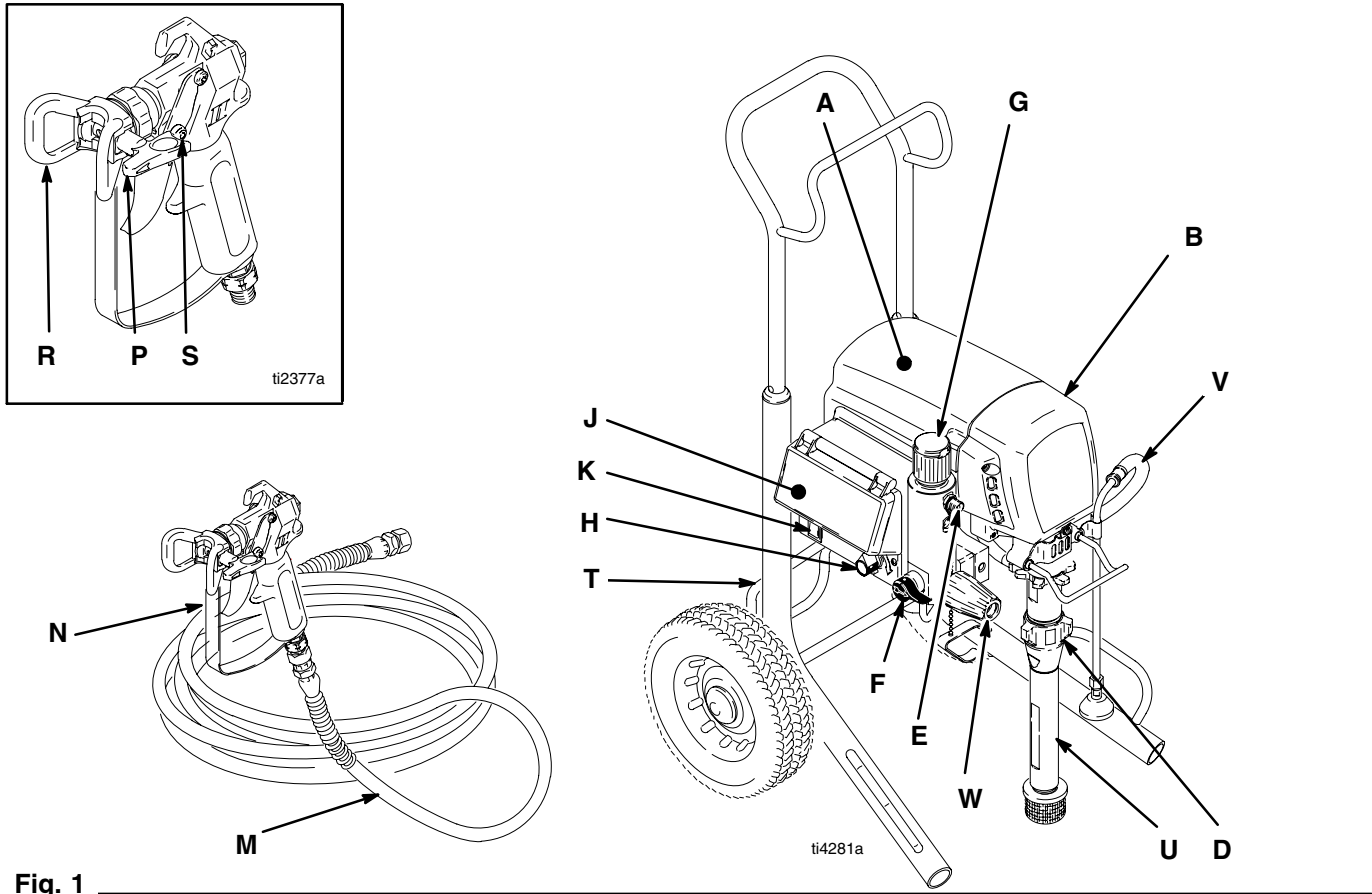



Fig. 1

A	Motor	DC motor, permanent magnet, totally enclosed, fan cooled
B	Drive Assembly	Transfers power from DC motor to displacement pump
D	Displacement Pump	Transfers fluid to be sprayed from source through spray gun
E	Fluid Outlet	Spray gun is connected here
F	Prime Valve	Used to prime and drain sprayer (also relieves fluid outlet pressure) when open
G	Fluid Filter	Final filter of fluid to spray gun
H	Pressure Adjusting Knob	Controls fluid outlet pressure
J	Pressure Control	Controls motor speed to maintain fluid outlet pressure at displacement pump outlet. Works with pressure adjusting knob.
K	ON/OFF Switch	Power switch that controls main power to sprayer
M	50 ft (15 m) Main Hose	1/4 in. ID, grounded, nylon hose with spring guards on both ends
N	Spray Gun	High pressure spray gun with gun safety latch
P	Spray Tip	Uses high pressure fluid to clear tip clogs without removing tip from spray gun
R	HandTite™ Tip Guard	Tip guard reduces risk of injection injury
S	Gun Safety Latch	Gun safety latch inhibits accidental triggering of spray gun. Contractor II gun shown. Refer to your gun manual to properly set your gun safety latch.
T	Hose Rack	Holds wrapped hose for storage
U	Suction Tube	Transfers fluid to be sprayed from source to pump
V	Drain Tube	Fluid outlet used to drain and prime the sprayer
W	AutoClean	Reverse flush system

General Repair Information

Pressure Relief Procedure

⚠ WARNING



INJECTION HAZARD
System pressure must be manually relieved to prevent system from starting or spraying accidentally. Fluid under high pressure can be injected through skin and cause serious injury. To reduce risk of injury from injection, splashing fluid, or moving parts, follow **Pressure Relief Procedure** whenever you:

- are instructed to relieve pressure,
- stop spraying,
- check or service any system equipment,
- or install or clean spray tip.

1. Turn pressure to zero.
2. Turn ON/OFF switch to OFF.
3. Unplug power supply cord.
4. Hold metal part of gun firmly to grounded metal pail. Trigger gun to relieve pressure.
5. Lock gun safety latch.
6. Open prime valve. Leave prime valve open until ready to spray again.

If suspected that spray tip or hose is completely clogged, or that pressure has not been fully relieved after following steps above, VERY SLOWLY loosen tip guard retaining nut or hose end coupling to relieve pressure gradually, then loosen completely. Now clear tip or hose obstruction.

CAUTION

To reduce risk of pressure control malfunction:

- Use needle nose pliers to disconnect wire. Never pull on wire, pull on connector.
- Mate wire connectors properly. Center flat blade of insulated male connector in female connector.
- Route wires carefully to avoid interference with other connections of pressure control. Do not pinch wires between cover and control box.

1. **Keep all screws, nuts, washers, gaskets, and electrical fittings** removed during repair procedures. These parts are not normally provided with replacement assemblies.

⚠ WARNING



**ELECTRIC SHOCK HAZARD
MOVING PARTS HAZARD
HOT SURFACE HAZARD**

To reduce risk of serious injury, including electric shock, do not touch moving or electrical parts with fingers or tools while testing repair. Shut off and unplug sprayer when inspection is complete. Install all covers, guards, gaskets, screws, washers and shroud before operating sprayer.

2. **Test repair** after problem is corrected.
3. **If sprayer does not operate properly**, review repair procedure to verify procedure was done correctly. If necessary, see Troubleshooting, pages 6 – 9, for other possible solutions.

Grounding

⚠ WARNING

Improper installation or alteration of grounding plug results in risk of electric shock, fire or explosion that could cause serious injury or death.

1. Ultimate Mx II 695, 795 and 1095 100–120 Vac models require a 50/60 Hz, 15A circuit with a grounding receptacle. Ultimate Mx II 1595 120 Vac models require a 50/60 Hz 20A circuit with a grounding receptacle; 220–240 Vac models require a 50/60 Hz, 10A circuit with a grounding receptacle. See Fig. 2.
2. Do not alter ground prong or use adapter.

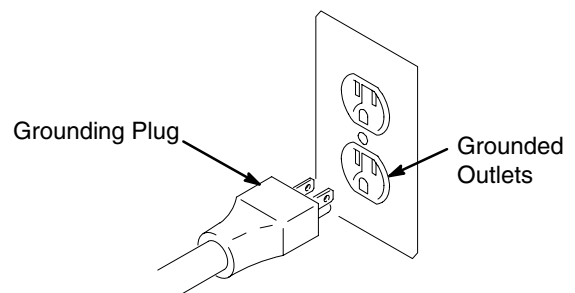

Fig. 2

3. 120 Vac: A 12 AWG, 3 wires with grounding prong, 300 ft (90 m) extension cord may be used.
220–240 Vac: You may use a 3-wire, 1.0 mm (12 AWG) (minimum) extension cord up to 90 m long. Long lengths reduce sprayer performance.

Troubleshooting



Relieve pressure; page 5.

Mechanical/Fluid Flow

TYPE OF PROBLEM	WHAT TO CHECK <i>If check is OK, go to next check</i>	WHAT TO DO <i>When check is not OK refer to this column</i>
Low Output or Pressure	1. For worn spray tip.	1. Follow Pressure Relief Procedure Warning , then replace tip. See your separate gun or tip manual.
	2. Spray tip clogged.	2. Relieve pressure. Check and clean spray tip.
	3. Paint supply.	3. Refill and reprime pump.
	4. Intake strainer clogged.	4. Remove and clean, then reinstall.
	5. To see if intake valve ball and piston ball are seating properly.	5. Remove intake valve and clean. Check balls and seats for nicks; replace if necessary, page 16. Strain paint before using to remove particles that could clog pump.
	6. Suction hose connections.	6. Tighten any loose connections. Check for missing or damaged seals.
	7. Filter clogged.	7. Relieve pressure. Check and clean filter.
	8. Prime valve leaking.	8. Relieve pressure. Repair prime valve.
	9. Verify pump does not continue to stroke when gun trigger is released. (Prime valve not leaking.)	9. Service pump. See page 16.
	10. Leaking around throat packing nut which may indicate worn or damaged packings. See page 16.	10. Replace packings, page 16. Also check piston valve seat for hardened paint or nicks and replace if necessary. Tighten packing nut/wet-cup.
	11. Pump rod damage.	11. Repair pump, page 16.
	12. Low stall pressure.	12. Do either or both: a. Turn pressure control knob fully clockwise. Make sure pressure control knob is properly installed to allow full clockwise position. b. Try a new pressure transducer.
Motor runs but pump does not stroke	1. Displacement pump pin (32) (damaged or missing), page 16.	1. Replace pump pin if missing. Be sure retainer spring (31) is fully in groove all around connecting rod, page 16.
	2. Connecting rod assembly (43) for damage, page 12.	2. Replace connecting rod assembly, page 12.
	3. Gears or drive housing, page 12.	3. Inspect drive housing assembly and gears for damage and replace if necessary, page 12.

Troubleshooting

Electrical

Symptom: Sprayer does not run or stops running

- 
 Relieve pressure; page 5.
- Plug sprayer into correct voltage, grounded outlet
- Set power switch OFF for 30 seconds and then ON again. This ensures sprayer is in normal run mode.
- Turn pressure control knob up 1/2
- View digital display

WARNING

To avoid electrical shock or moving parts hazards when covers are removed for troubleshooting, wait 30 seconds after unplugging power cord for stored electricity to dissipate. Keep clear of electrical and moving parts during troubleshooting procedures.

- If no digital display is available, use control board status light to troubleshoot problems: Turn ON/OFF switch OFF, remove control cover and then turn power back ON. Observe status light.

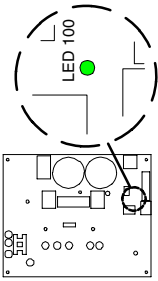
DIGITAL DISPLAY	CONTROL BOARD STATUS LIGHT	INDICATION	WHAT TO DO
Blank	Never lights 	No power to control board	<ol style="list-style-type: none"> Verify required voltage is present Check wiring connections to control board Perform continuity check on power cord and switch. Replace power cord or switch as needed. If steps 1 – 3 are ok, replace control board
— psi	Blinks once and stops	No RUN command to control board. Potentiometer or transducer problem	<ol style="list-style-type: none"> Make sure prime valve is open and there is no pressure in the system Turn pressure control knob clockwise Check potentiometer connection to control board Check pressure control knob alignment to potentiometer shaft. Turn shaft fully clockwise and attach knob in full ON position. Unplug potentiometer. Short out center pin of control board potentiometer connector to each outer pin (one at a time). If sprayer runs, replace potentiometer. Check transducer connection Disconnect and reconnect transducer plug to ensure good connection with control board socket. Check that transducer contacts are clean. Open prime valve. Connect a known good transducer in place of the sprayer transducer. Set sprayer ON. Replace transducer If sprayer runs. Replace control board If sprayer does not run.

Troubleshooting

Electrical

DIGITAL DISPLAY	CONTROL BOARD-STATUS LIGHT	INDICATION	WHAT TO DO
Displays high pressure when prime valve is open and there is no pressure in sprayer.	—	Improper pressure signal to control	Open prime valve. Connect a known good transducer in place of the sprayer transducer. Set sprayer ON. Replace transducer If sprayer runs. Replace control board If sprayer does not run.
E=02	Blinks 2 x repeatedly	Control board is receiving excessive pressure signal from transducer. Transducer may be damaged or fluid flow path may be clogged.	<ol style="list-style-type: none"> 1. Check fluid path for clogs, such as a clogged filter. 2. Open prime valve and gun if running AutoClean. 3. Use airless paint spray hose with no metal braid, 1/4 in. x 50 ft minimum. Smaller hose or metal braid hose may result in high-pressure spikes. 4. Replace transducer if fluid path is not clogged and proper hose is used.
E=03	Blinks 3 x repeatedly	Transducer or transducer connection error	<ol style="list-style-type: none"> 1. Check transducer connection 2. Disconnect and reconnect transducer plug to ensure good connection with control board socket. Check that transducer contacts are ok. 3. Open prime valve. Connect a known good transducer in place of the sprayer transducer. Set sprayer ON. Replace transducer If sprayer runs. Replace control board If sprayer does not run.

Troubleshooting

Electrical

DIGITAL DISPLAY	CONTROL BOARD-STATUS LIGHT	INDICATION	WHAT TO DO
E=05	Blinks 5 x repeatedly	Possible locked pump or drive. May be motor connection or wiring error.	<ol style="list-style-type: none"> 1. Check motor wiring connections 2. Check for locked or frozen pump or drive train 3. If all motor wiring connections are OK and pump/drive train are not locked up, replace motor
E=06	Blinks 6 x repeatedly	Motor is too hot or motor/thermal device connection may be bad.	<ol style="list-style-type: none"> 1. Check all wire connections from motor to control board 2. If connections are all ok, allow sprayer to cool. If sprayer runs when cool, correct cause of overheating. Keep sprayer in cooler location with good ventilation. Make sure motor air intake is not blocked.
E=07	Blinks 7 x repeatedly	Exceeded 2000 psi during timed flush cycle	<p>This error only occurs in flush timer mode</p> <ol style="list-style-type: none"> 1. Make sure prime valve and gun are open 2. Make sure no flow obstructions or clogged filter
E=09	Blinks 9 x repeatedly	Motor sensor failure	Make sure motor sensor (resolver) is connected to the control board and check wiring for damage
E=10	Blinks 10 x repeatedly	High control board temperature	<ol style="list-style-type: none"> 1. Make sure the motor air intake is not blocked 2. Make sure control board is properly connected to the back plate and that conductive thermal paste is used on the power components, Fig. 3
E=11	Blinks 11 x repeatedly	Excessive motor speed	Check for damaged gears or disconnected pump
E=12	Blinks 12 x repeatedly	High Current	<ol style="list-style-type: none"> 1. Check for locked or frozen pump or drive train 2. Check for possible short circuits in wiring 3. Check pressure output and replace transducer if pressure is excessive
E=13	Blinks 13 x repeatedly	Model not selected	Control board identity resistors must be properly clipped to identify model type, manual 310657
EMPTY	—	EMPTY on digital display indicates a loss of paint to the pump or a severe loss in pressure	<ol style="list-style-type: none"> 1. Check for empty paint condition, clogged inlet strainer, failed pump or severe leak. Turn pressure control knob to zero to restart sprayer. 2. WatchDog feature can be deactivated. See Operation Manual.

Pressure Control Repair

Motor Control Board

Removal

-  Relieve pressure; page 5.
- Fig. 3. Remove four screws (38) and cover (96).
- Disconnect display connector (A) from motor control board (95).
- Remove bottom two screws (39) and allow control panel (68) to hang down freely.
- Disconnect control board power lead(s) (D) from ON/OFF switch (33) and motor control board (95).
- Disconnect potentiometer connector (C) from motor control board.
- Disconnect 15/20A switch (178) (1595).
- Disconnect transducer connector (E) from motor control board.
- Disconnect motor connectors (F, G and H) from motor control board.
- Remove top two screws (39) and control box (61).
- Remove five screws (27), three screws (102) and motor control board.

Pressure Adjust Potentiometer

Removal

-  Relieve pressure; page 5.
- Fig. 3. Remove four screws (38) and cover (96).
- Disconnect potentiometer connector (C) from motor control board (95).
- Remove knob (34) with a hex wrench.
- Remove gasket (115), nut and potentiometer (82) from control panel (68).

Installation

- Fig. 3. Apply small amount of thermal compound 110009 (5) to shaded component areas on rear of motor control board (95).

CAUTION

To reduce risk of motor control board failure, do not overtighten screws (102) which can damage the electric components.

- Install motor control board (95) with five screws (27). Torque to 10–12 in-lb (1.13 – 1.35 N·m). Install and torque three screws (102) to values shown in Fig 3.
- Connect motor connectors (F, G and H) to motor control board.
- Install control box (61) with top two screws (39).
- Connect transducer connector (E) to motor control board.
- Connect 15/20A switch (178) (1595).
- Connect motor control board power lead(s) (D) to ON/OFF switch (33).
- Connect potentiometer connector (C) to motor control board.
- Install control panel (68) with two screws (39) .
- Connect display connector (A) to motor control board (95).
- Install cover (96) with four screws (38).

Installation

- Install gasket (115), nut and potentiometer (82) on control panel (68). Torque nut to 30–35 in-lb (3.38–3.95 N·m).
- Install knob (34) with a hex wrench.
- Connect potentiometer connector (C) to motor control board.
- Install cover (96) with four screws (38).

Pressure Control Transducer

Removal

1.  Relieve pressure; page 5.
2. Fig. 3. Remove four screws (38) and cover (96).
3. Disconnect transducer connector (E) from motor control board (95).
4. Disconnect potentiometer connector (C) from motor control board.
5. Remove four screws (39) and control box (61). Allow control panel to hang down freely.
6. Remove transducer (86) and o-ring (20) from filter base (67).

7. Remove grommet (40) from transducer and save for reuse.

Installation

1. Install o-ring (20) and transducer (86) in filter base (67). Torque to 35–45 ft-lb (47–61 N·m).
2. Install grommet (40) onto transducer (86).
3. Connect transducer connector (E) to motor control board.
4. Install control box (61) and control panel (68) with four screws (39).
5. Connect potentiometer connector (C) to motor control board.
6. Install cover (96) with four screws (38).

120 Vac

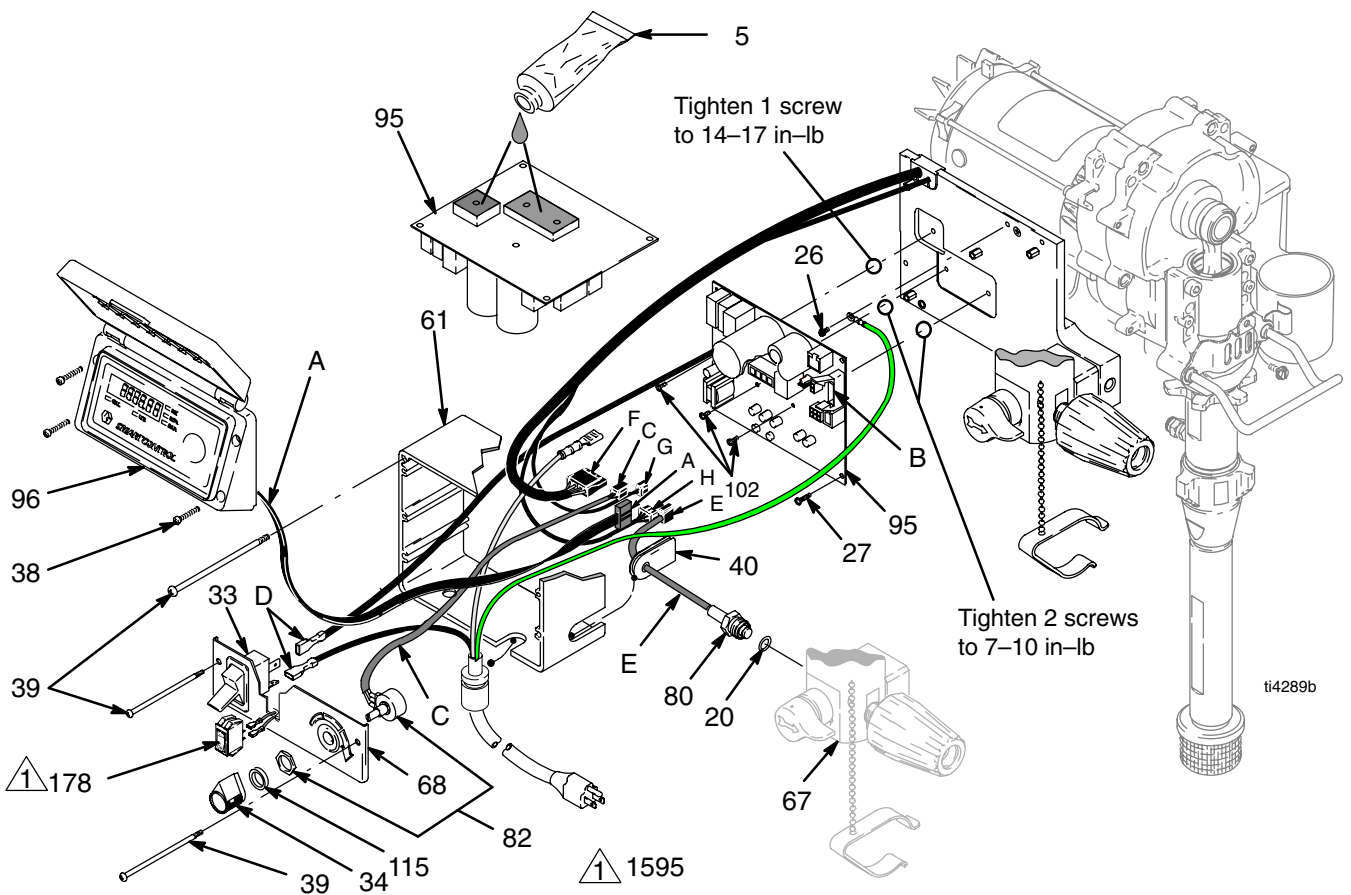



Fig. 3

Drive and Bearing Housing Replacement

CAUTION

Do not drop gear cluster (89) when removing drive housing (90). Gear cluster may stay engaged in motor front end bell or drive housing.

Disassembly

-  1. Relieve pressure; page 5.
2. Remove screw (31), two nuts (24), pail hanger (55) and pump rod cover (108).
3. Remove pump (91); **Displacement Pump Replacement**, page 16.
4. Fig. 4. Remove two screws (31) and shroud (72).
5. Remove four screws (31) and front cover (51).
6. Remove four screws (14) and washers (12) to remove bearing housing (83) and connecting rod (85).

7. Remove five screws (6) and pull drive housing (90) off motor (84).

Assembly

Fig. 5. Make sure gear (89) and thrust washers (28, 30, 90a, 36) are in place. Brush grease onto gear teeth.

1. Fig. 4. Push drive housing (90) onto motor (84) and install with five screws (6). Torque to 190–210 in-lb (21–23 N·m).
2. Install bearing housing (83) with four screws (14) and washers (12). Torque to 25–30 ft-lb (34–40 N·m).
3. Install front cover (51) with four screws (31).
4. Install shroud (72) with two screws (31).
5. Install pump (41); **Displacement Pump Replacement**, page 16.
6. Install pump rod cover (108) and pail hanger (55) with screw (31) and two nuts (24).

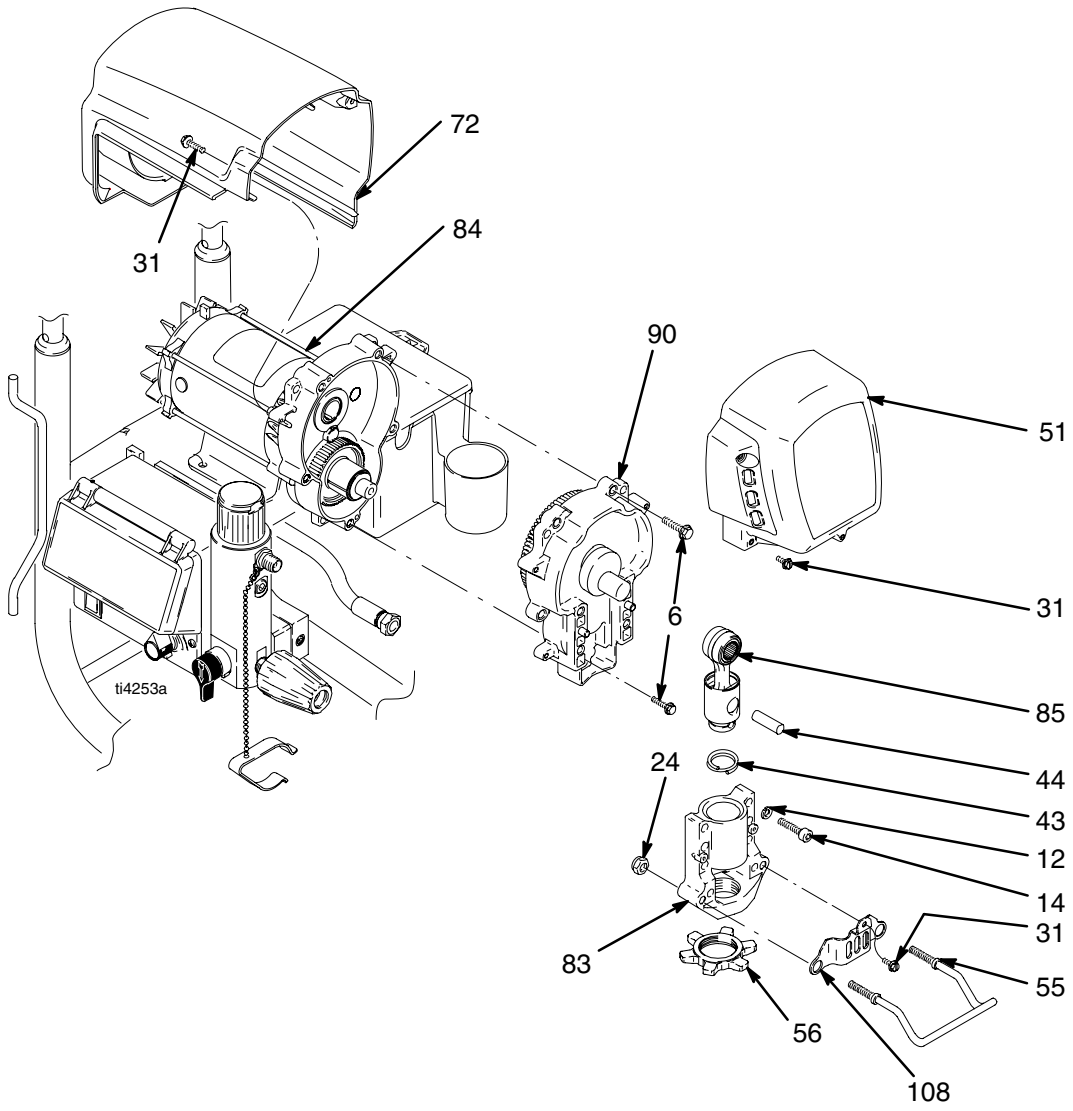

Fig. 4

Motor Replacement

Removal

1.  Relieve pressure; page 5.

2. Remove pump (91); **Displacement Pump Replacement**, page 16.

CAUTION

Do not drop gear cluster (89) when removing drive housing (90). Gear cluster may stay engaged in motor front end bell or drive housing.

3. Remove drive housing (89); **Drive Housing Replacement**, page 12.
4. Fig. 5. Remove four screws (38) and control cover (96).
5. Remove bottom two screws (39) and allow control panel (68) to hang down freely.
6. Disconnect all three motor leads from motor control board (95).
7. Remove top two screws (39) and control housing (61).
8. Remove strain relief (29) from motor wires and power bar plate (69).
9. Remove two screws (23) and nuts (19) on side opposite control.
10. Loosen two nuts (19) on side near control and remove motor (84) from cart frame (62).

Installation

1. Slide new motor (84) under two screws (23) in cart frame (62) near control.
2. Install two screws (23) and nuts (19) on motor side opposite control.
3. Tighten all four screws (23) and nuts (19). Torque nuts to 115–135 in-lb (13–15 N·m).
4. Install strain relief (29) onto motor wires and into power bar plate (69)
5. Install control housing (61) with top two screws (39).
6. Connect all three motor leads to motor control board (95).
7. Install control panel (68) with two screws (39).
8. Install control cover (96) with four screws (38).
9. Install drive housing (42); **Drive Housing Replacement**, page 12.
10. Install pump (13); **Displacement Pump Replacement**, page 16.

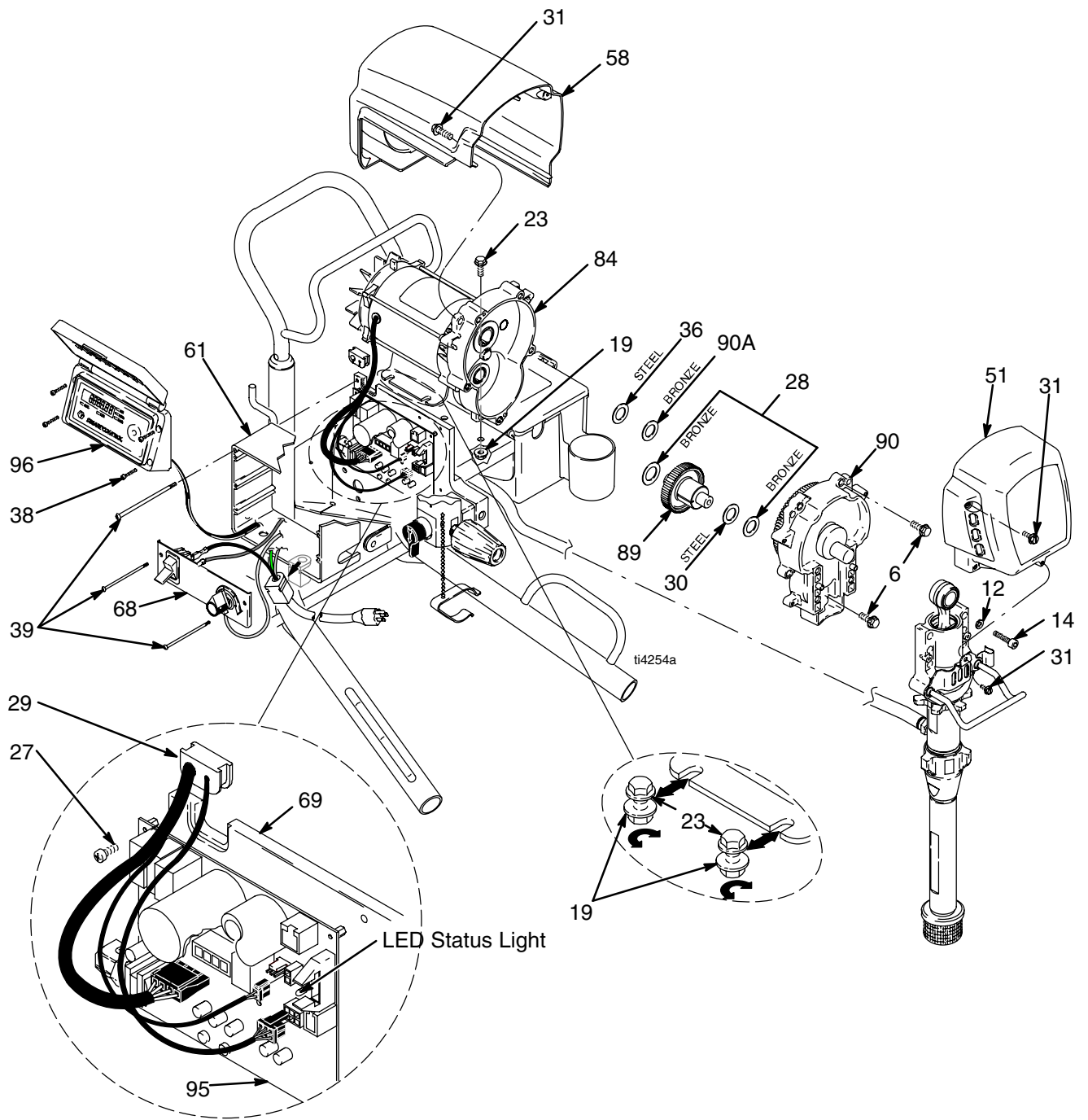



Fig. 5

Displacement Pump Replacement

See manual 310643 for pump repair instructions.

See manual 309943, 309944 or 309951 – 309954 for applicable sprayer part number references.

Removal

1. Flush pump (13).
2.  Relieve pressure; page 5.
3. Fig. 6. Remove screw (31) and slide pump rod shield (108) forward.

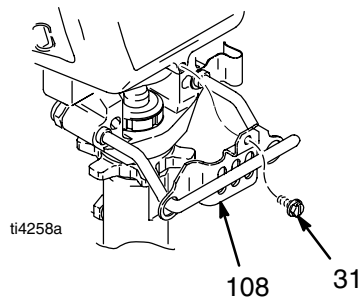

Fig. 6

4. Fig. 8. Cycle pump in JOG mode until pump pin (44) is in position to be removed. Turn power switch OFF and unplug power cord. Push up retaining ring (43) and push pump pin out.
5. Fig. 7. Remove suction tube (76), hose (94) and any washers and o-rings.
6. Loosen pump jam nut (56). Unscrew pump.

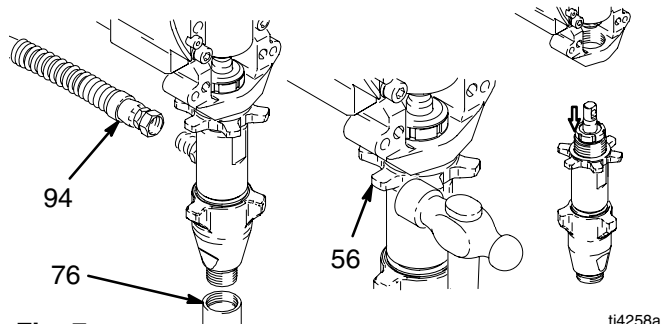

Fig. 7

Installation

WARNING

If pump pin works loose, parts could break off due to force of pumping action. Parts could project through the air and result in serious injury or property damage.

CAUTION

If the pump jam nut loosens during operation, the threads of the drive housing will be damaged.

1. Fig. 8. Extend pump piston rod 1.5 in. Apply grease to top of pump rod at (A) or inside connecting rod.

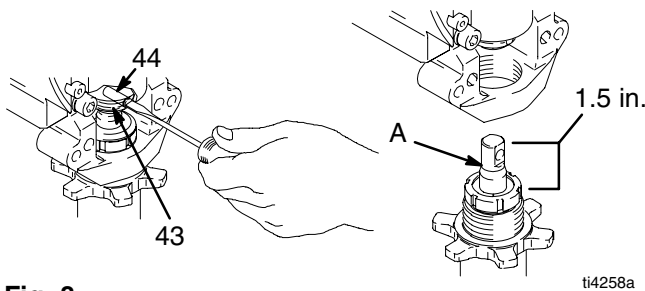

Fig. 8

4. Screw in pump until threads are flush with drive housing opening. Align pump outlet to back.
5. Fig. 7. Install washers, o-rings and suction tube (76) and hose (94).
6. Fig. 9. Screw jam nut (56) up onto pump until nut stops. Tighten jam nut by hand, then tap 1/8 to 1/4 turn with a 20 oz (maximum) hammer to approximately 75 ± 5 ft-lb (102 N.m).

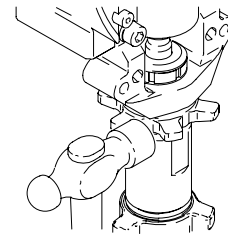

Fig. 9

7. Fig. 6. Install pump rod shield (108) with screw (31).
8. Fig. 10. Fill packing nut with Graco TSL until fluid flows onto top of seal.

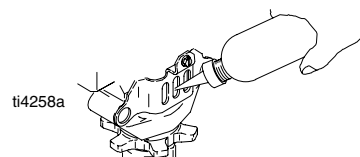
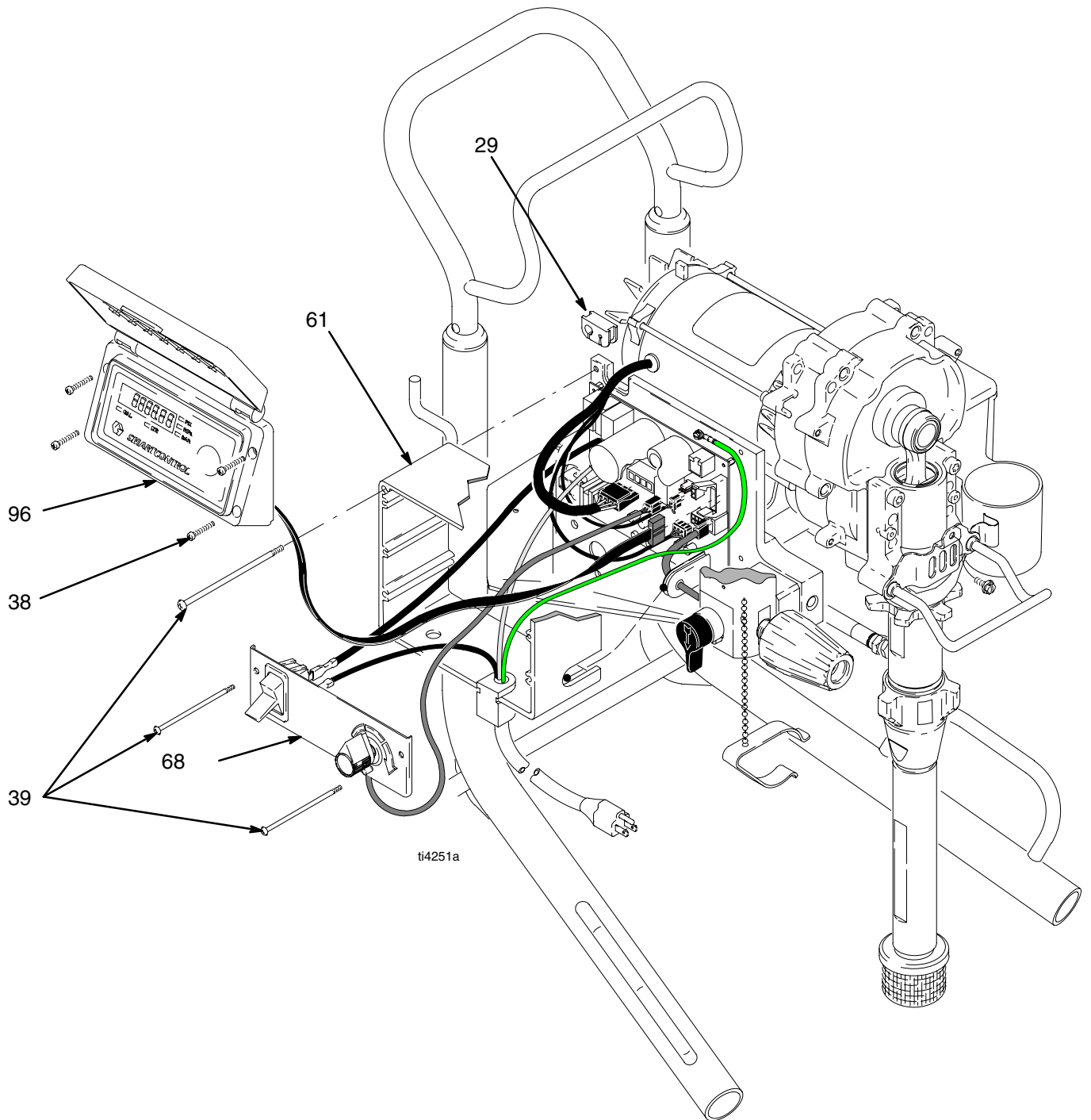

Fig. 10

2. Install pump pin (44). Verify retaining spring (43) is in groove of connecting rod (85).
3. Push pump up until pump threads engage.

3-D Wiring Diagram



See Parts manual for wiring schematic

Fig. 11

Technical Data

Model	100–120V, A, Hz	220–240V, Ø, A, Hz	Generator Minimum W	Motor HP (W)	Cycles per gallon (liter)	Maximum Delivery gpm (lpm)	Maximum Tip size		Fluid Outlet npsm
							1 Gun	2 Guns	
695	14, 50/60	9, 50/60	5000	1.75 (1300)	243 (64)	0.75 (2.8)	0.027	N/A	1/4 in.
795	15, 50/60	10, 50/60	5000	2.00 (1490)	195 (52)	0.95 (3.6)	0.031	0.021	1/4 in
1095	15, 50/60	10, 50/60	5000	2.20 (1640)	123 (33)	1.1 (4.1)	0.033	0.023	1/4 in
1595	20/15, 50/60	N/A	5000	2.5 (1860)	110 (29)	1.25 (4.7)	0.037	0.025	1/4 in

Basic Sprayer Wetted Parts:
zinc- and nickel-plated carbon steel, nylon, stainless
steel, PTFE, Acetel, leather, UHMWPE, aluminum,
tungsten carbide, PEEK, brass

Noise Level
Sound power 91 dBa*
Sound pressure 82 dBa*
* per ISO 3744; measured at 3.1 feet (1 m)

Dimensions

Model	Weight lb (kg)		Height in. (cm)		Length in. (cm)	Width in. (cm)
	Lo-Boy	Hi-boy	Lo-Boy	Hi-Boy		
695	94 (43)	94 (43)	26.5 (67.3) Handle down, 38.8 (98.6) Handle up	28.5 (72.4) Handle down, 38.75 (98.4) Handle up	25.75 (65.4)	20.5 (52.1)
795	98 (45)	98 (45)	26.5 (67.3) Handle down, 38.8 (98.6) Handle up	28.5 (72.4) Handle down, 38.75 (98.4) Handle up	25 (63.5)	20.5 (52.1)
1095	N/A	120 (55)	N/A	29.5 (74.9) Handle down, 38.5 (97.8) Handle up	26 (66)	22.5 (57.2)
1595	N/A	125 (57)	N/A	29.5 (74.9) Handle down, 38.5 (97.8) Handle up	26 (66)	22.5 (57.2)

Graco Phone Number

TO PLACE AN ORDER OR FOR SERVICE, contact your Graco distributor, or call **1-800-690-2894** to identify the nearest distributor.

*All written and visual data contained in this document reflect the latest product information available at the time of publication.
Graco reserves the right to make changes at any time without notice.*

mm 309942

This manual contains English

Graco Headquarters: Minneapolis

International Offices: Belgium, Korea, China, Japan

GRACO INC. P.O. BOX 1441 MINNEAPOLIS, MN 55440-1441

www.graco.com

PRINTED IN U.S.A. 1/2004, Rev 11/2005