

## Displacement Pump

310894G

**- For portable spray application of architectural paints and coatings  
or replacement pump for Graco GMax™ II sprayers -**

*3300 psi (228 bar, 22.8 MPa) Maximum Working Pressure*

**Model 287512, Series A**

GMax II 3900 Sprayer,  
Rental Pro 360G

**Model 287513, Series A**

GMax II 5900 Sprayer,  
UltraMax II 1095/1595 with ProConnect

**Model 287579, Series A**

GMax II 5900HD Sprayer

**Model 249122, Series A**

GMax II 7900 Sprayer,  
Ultra Max II 1895

**Model 287928, Series A**

Mark V™ International

**Model 287929, Series A**

Mark V North America

**Model 289590, Series A**

TexSpray 7900HD,  
Mark X, 230V, Domestic

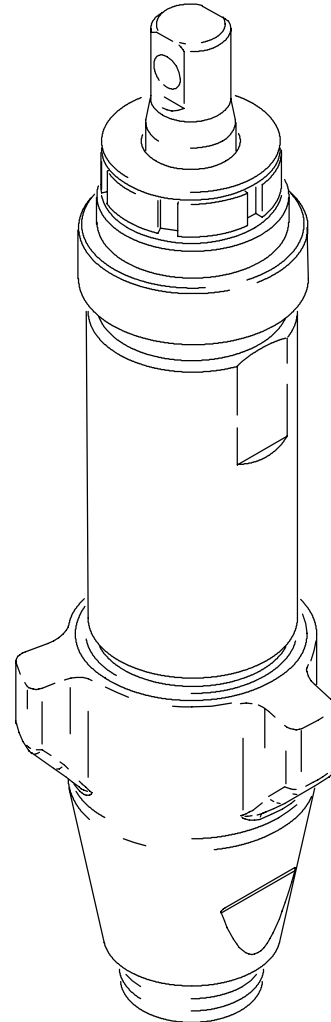

ti6177a



**Important Safety Instructions**

Read all warnings and instructions in this manual  
and in your sprayer manual. Save these  
instructions.

**PROVEN QUALITY. LEADING TECHNOLOGY.**

# Table of Contents

Warnings .....	2	287579 .....	13
Service .....	3	287928 .....	14
Technical Data .....	9	287929 .....	15
Parts, Pump		289590 .....	16
287512 .....	10	Warranty .....	18
287513 .....	11	Graco Phone Number .....	18
249122 .....	12		

## Warnings

### Warning Symbol





This symbol alerts you to the possibility of serious injury or death if you do not follow the instructions.

### Caution Symbol



This symbol alerts you to the possibility of damage to or destruction of equipment if you do not follow the instructions.

## ! WARNING

 <small>INSTRUCTIONS</small>	<p><b>EQUIPMENT MISUSE HAZARD</b></p> <p>Misuse can cause death or serious injury.</p> <ul style="list-style-type: none"> <li>• Do not exceed the maximum working pressure temperature rating of the lowest rated system component. See <b>Technical Data</b> in all equipment manuals.</li> <li>• Use fluids and solvents compatible with equipment wetted parts. See <b>Technical Data</b> in all equipment manuals. Read manufacturer fluid and solvent warnings.</li> <li>• Check equipment daily. Repair or replace worn or damaged parts immediately.</li> <li>• Do not alter or modify equipment.</li> <li>• Read all instruction manuals, tags, and labels before operating the equipment.</li> <li>• Use equipment only for its intended purpose. Call your Graco distributor for information.</li> <li>• Do not use 1,1,1-trichloroethane, methylene chloride, other halogenated hydrocarbon solvents or fluids containing such solvents in pressurized aluminum equipment. Such use could result in a chemical reaction, with the possibility of explosion.</li> <li>• Comply with all applicable safety regulations.</li> </ul>
	<p><b>MOVING PARTS HAZARD</b></p> <p>Moving parts can pinch or amputate your fingers.</p> <ul style="list-style-type: none"> <li>• Keep clear of moving parts.</li> <li>• Do not operate equipment with protective guards or covers removed.</li> <li>• Pressurized equipment can start without warning. Before checking, moving or servicing equipment, follow the <b>Pressure Relief Procedure</b> on page 3. Disconnect power cord.</li> </ul>

# Service

## Pressure Relief Procedure

 **WARNING**



**PRESSURIZED EQUIPMENT HAZARD**  
The system pressure must be manually relieved to prevent the system from starting or spraying accidentally. To reduce the risk of an injury from accidental spray from the gun, splashing fluid, or moving parts, follow the **Pressure Relief Procedure** whenever you:

- are instructed to relieve the pressure,
- stop spraying,
- check or service any of the system equipment,
- or install or clean the spray nozzle.

1. Lock gun trigger safety.
2. Turn engine ON/OFF switch to OFF.
3. Move pump switch to OFF and turn pressure control knob fully counterclockwise.
4. Unlock trigger safety. Hold metal part of gun firmly to side of grounded metal pail, and trigger gun to relieve pressure.
5. Lock gun trigger safety.
6. Open pressure drain valve. Leave open until ready to spray again.

*If you suspect that the spray tip or hose is completely clogged, or that pressure has not been fully relieved after following the steps above, VERY SLOWLY loosen tip guard retaining nut or hose end coupling to relieve pressure gradually, then loosen completely. Now clear tip or hose.*

## Pump Repair Kits

Pump	Repair Kit
287512	248212
287513	248213
287579	248213
249122	249123
287928	249189
287929	248213
289590	249123

## Tools Needed

Vise  
12 in. adjustable, open end wrench (2)  
Hammer, 20 oz maximum  
Small screwdriver  
Throat Seal Liquid  
Pick or long small screwdriver

## Cleaning and Inspecting Parts

1. Clean and inspect parts. Pay particular attention to the ball seats in the intake valve and piston, which must have no nicks or wear, and to the inside of the sleeve and the outside of the piston rod, which must not be worn or scratched. Replace worn or damaged parts.

 **WARNING**



**COMPONENT RUPTURE HAZARD**  
Never use sharp or pointed tools to remove sleeve or other components which could result in pump rupture and cause serious bodily injury. If the sleeve cannot be removed easily, return the sleeve and cylinder to your Graco distributor for removal.

2. Remove and clean the sleeve when you are repacking the pump.

# Service

## Disassembling the pump

Fig. 1. Remove packing nut (202) and throat adjustment spacer (228).

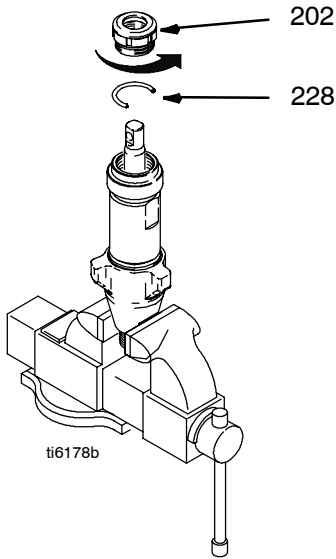

Fig. 1

Fig. 3. Disassemble intake valve. Clean and inspect. O-ring (227) may require a pick for removal.

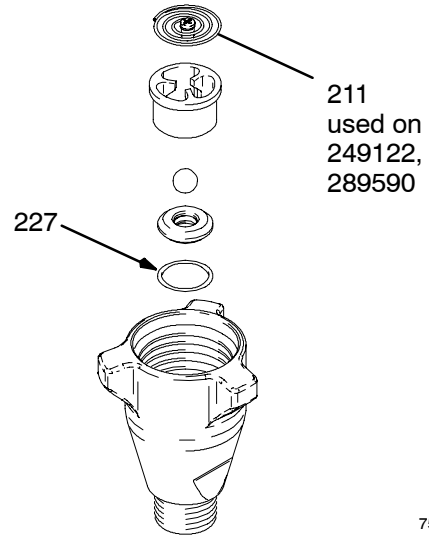

Fig. 3

Fig. 4. Tap piston rod out of cylinder with a hammer or flip over and tap piston rod out against a bench.

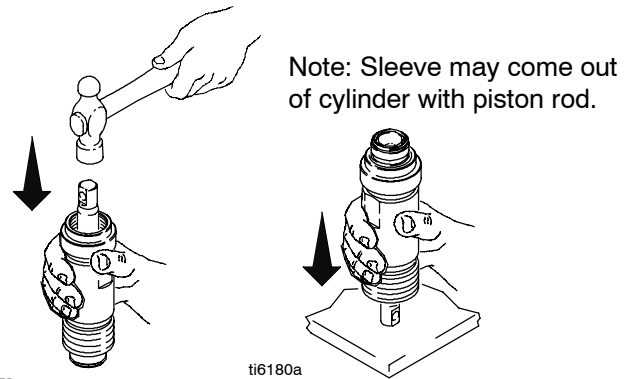

Fig. 4

Fig. 2. Unscrew intake valve from cylinder.

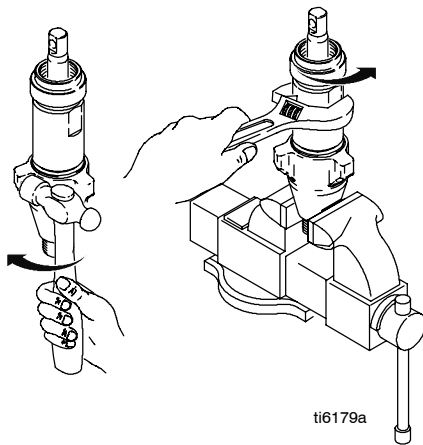

Fig. 2

Fig. 5. Remove piston rod from sleeve, or remove sleeve from cylinder.

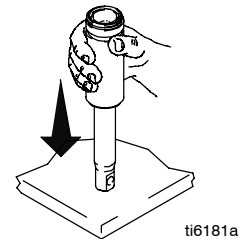

Fig. 5

# Service

**⚠ WARNING**

**COMPONENT RUPTURE HAZARD**  
Do not clean or wipe the piston valve threads. Cleaning the piston valve threads could destroy the special sealing patch and cause the piston valve to come loose during operation, causing pump bursting and possible serious bodily injury.

Fig. 6. Unscrew piston valve from piston rod. Clean and inspect parts. The piston has a special thread locking/sealing patch. Do not remove the patch. The patch allows four disassembly/assembly procedures before it is necessary to apply Loctite® to the threads.

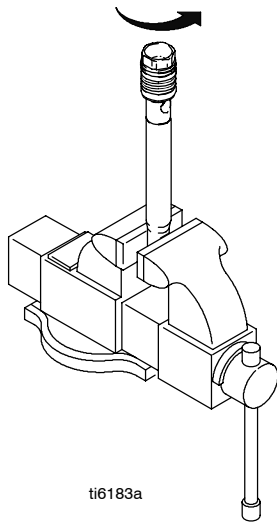

Fig. 6

ti6183a

Fig. 7. Remove packings and glands from piston rod.

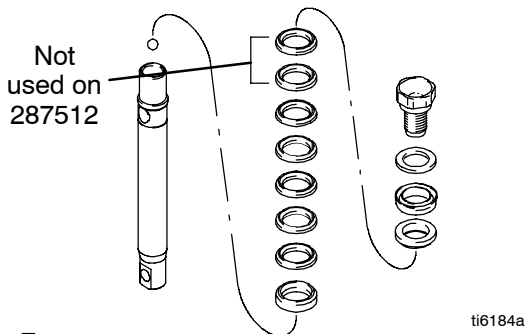

Fig. 7

ti6184a

Fig. 8. Remove throat packings and glands from cylinder. Discard throat packings and glands.

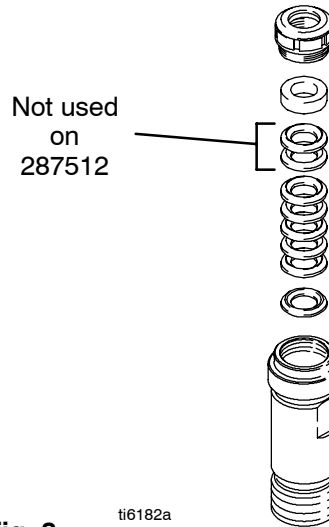
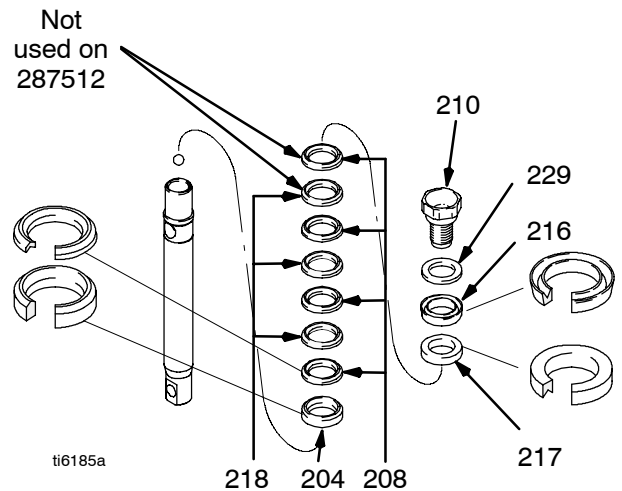

Fig. 8

ti6182a

## Assembling the pump

Fig. 9. Soak all leather packings in SAE 30W oil for 1 hour minimum prior to assembly. Stack male gland (204) on piston rod. Alternately stack UHMWPE (208) and leather (218) packings (note orientation) on piston rod. Install female gland (217). Install piston wiper (216) (note orientation) and backup washer (229) on piston valve (210). The special sealing patch on piston valve threads is good for four repackings. Use Loctite® on piston valve threads after four repackings.



ti6185a

Note: pump 249122 and 289590 do not use leather packings in piston stack. Alternately stack blue (208) and brown (218) packings on this pump.

Fig. 9

# Service

Fig. 10. Install ball (206) in piston rod. If Loctite® is applied to piston valve threads, ensure that none gets on ball.

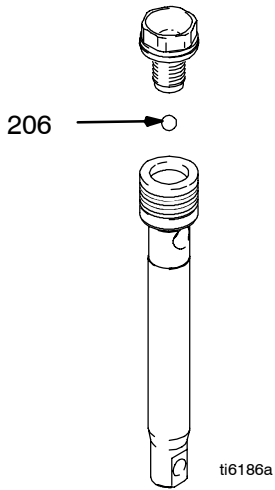

Fig. 10

Fig. 12. Soak all leather packings in SAE 30W oil for 1 hour minimum prior to assembly. Place male gland (204) in cylinder. Alternately stack UHMWPE (203) and leather packings (223) (note orientation). Place female gland (224) in top of cylinder. Seat packings.

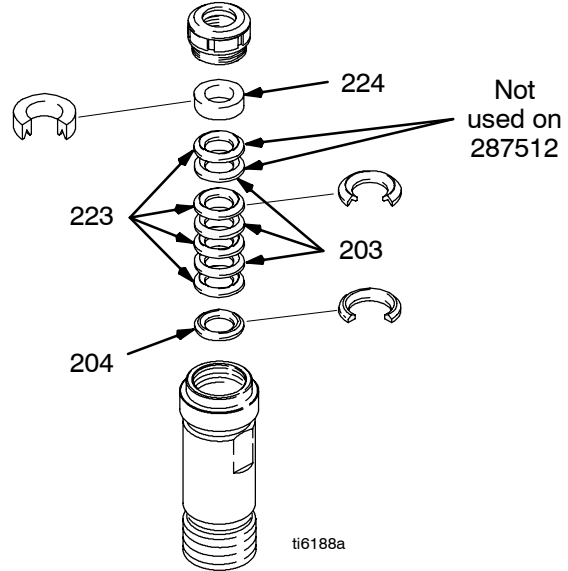

Fig. 12

Fig. 11. Tighten piston valve to piston rod as specified:

Torque to 27 +/- 3 ft-lb  
(36.61 +/- 4.06 N•m)  
(287512)

Torque to 55 +/- 3 ft-lb  
(74.57 +/- 4.06 N•m)  
(249122, 287513,  
289590)

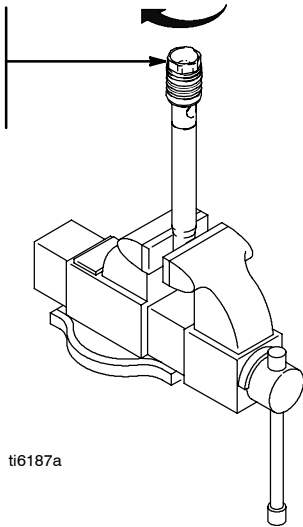

Fig. 11

Fig. 13. Install seal (201) into packing nut (202). Install throat adjustment spacer (228) onto packing nut. Loosely install packing nut into cylinder.

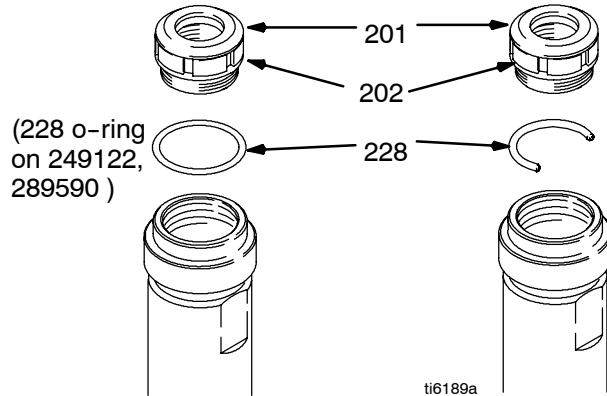

Fig. 13

# Service

## CAUTION

Never slide piston assembly (222) into top of sleeve (220) as this may damage piston packings.

Fig. 14. Grease o-rings (221) and place inside cylinder (205) and on sleeve (220). Slide sleeve (220) into bottom of cylinder (205). Replace o-ring (207) if desired.

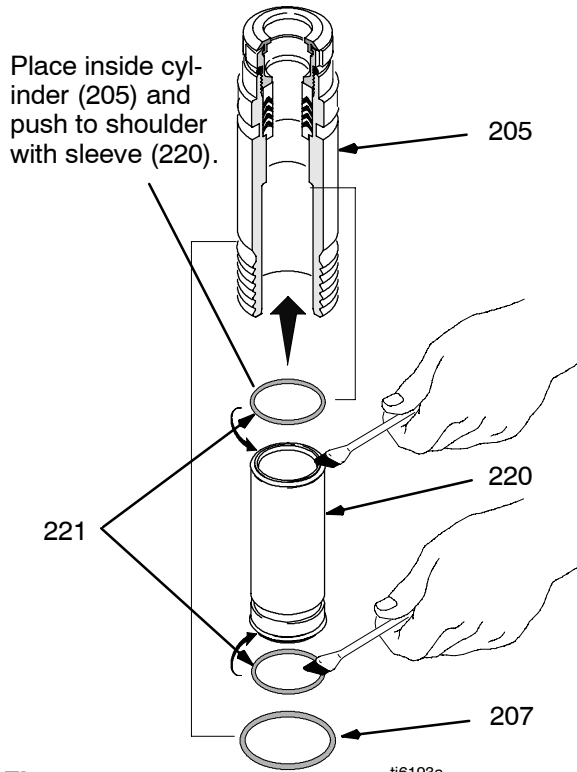

Fig. 14

Note: O-ring (207) is not required for safe pump operation.

Fig. 15. Grease top inch or two of piston rod (222) that goes through the sleeve/cylinder assembly throat packings (205). Grease piston packings at bottom of piston rod.

Carefully slide piston assembly (222) into bottom of sleeve/cylinder assembly (205) until pump rod protrudes at the top and piston packings are totally inside the sleeve (220).

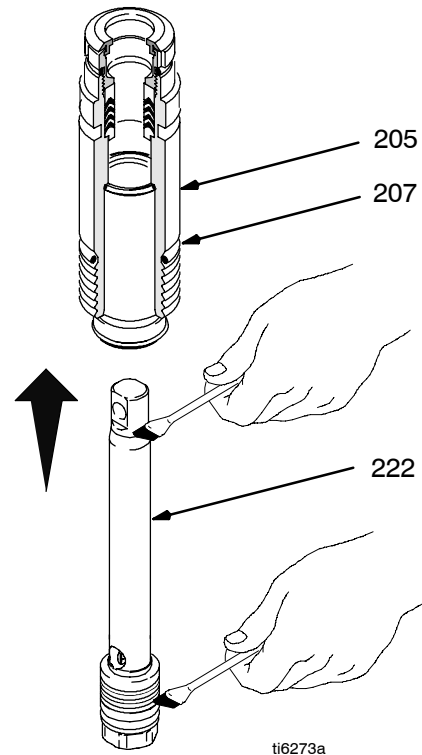
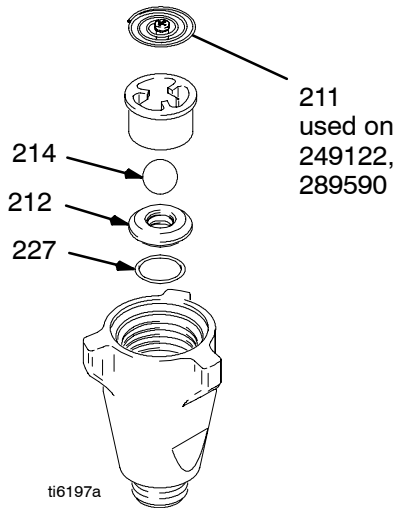

Fig. 15

# Service

Fig. 16. Reassemble intake valve with new o-ring (227), seat (212) and ball (214). Seat may be flipped over and used on other side. Clean seat thoroughly.



**Fig. 16**

Fig. 17. Install intake valve on cylinder. If a wrench is used torque as follows:

70 +/-5 ft-lb (94.91 +/- 6.77 N•m) (Model 287512)

80 +/-5 ft-lb (108.5 +/- 6.77 N•m)

(Model 287513, 287579)

200 +/-15 ft-lb (271.2 +/- 20.34 N•m)

(Model 249122, 289590)

If a wrench is not used, be sure intake valve is bottomed out against cylinder.

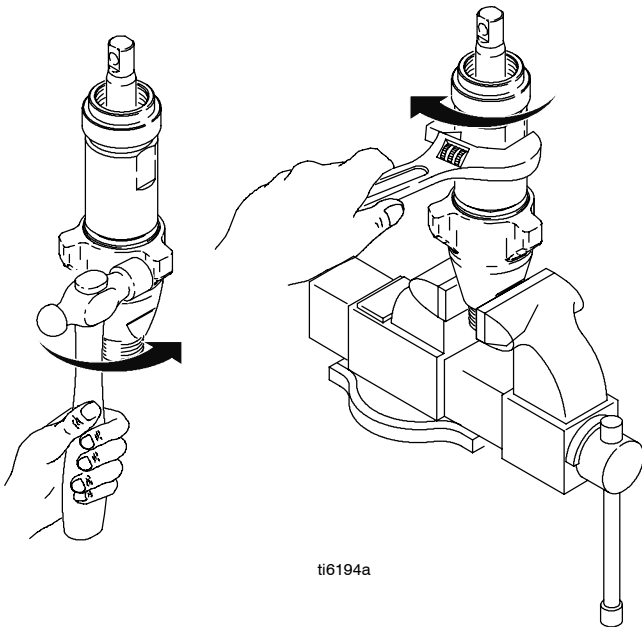

**Fig. 17**

Fig. 18. Torque packing nut (202) down onto adjustment spacer (228) 140 +/-10 in-lb (15.82 +/- 1.13 N•m).

Remove throat adjustment spacer (228) when pump packings begin to leak after much use. Then tighten packing nut down until leakage stops or lessens. This allows approximately 100 gallons of additional operation before a repacking is required.

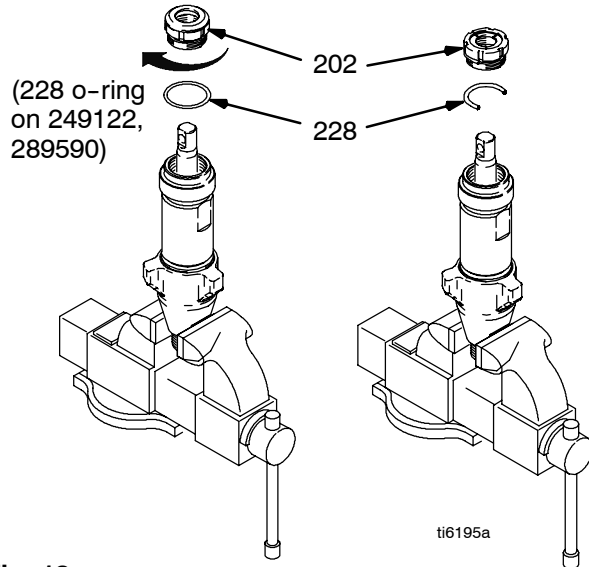

**Fig. 18**



# Service

## Cross Sectional Reference

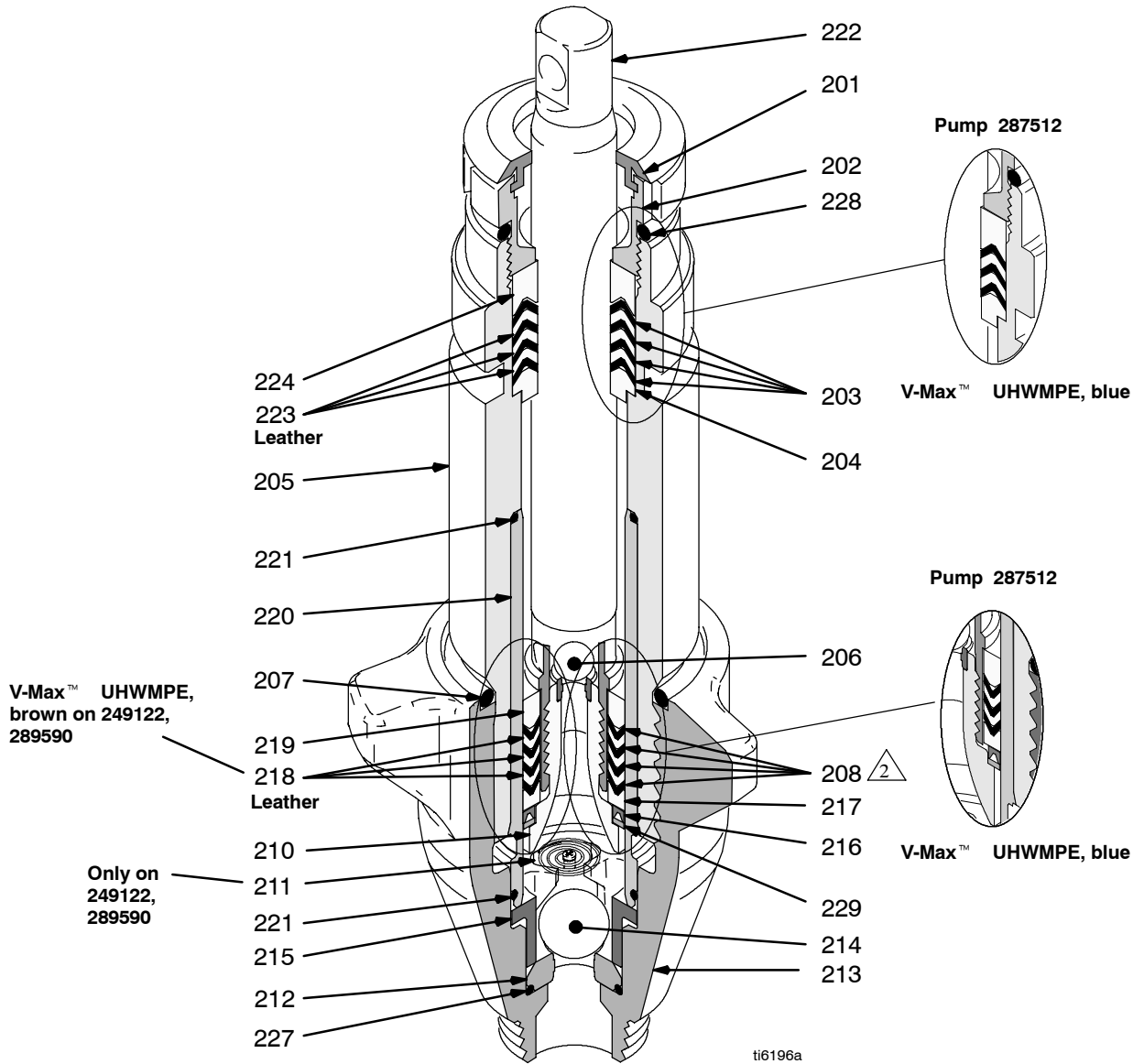

Fig 19

## Technical Data

Maximum working pressure ..... 3300 psi  
(228 bar, 22.8 MPa)

Fluid inlet size ..... 1-5/16 npt(m)

Fluid outlet size ..... 3/8 npt(f)  
Wetted parts ..... stainless steel, PTFE,  
leather, nylon, zinc-plated carbon steel,  
tungsten carbide, brass, fluoroelastomer,  
acetal, polyethylene

**NOTE:** Loctite® is a Loctite Company registered trademark.

# Parts - Pump 287512

## Model 287512, Series A

Ref No.	Part No.	Description	Qty.
201	179810	SEAL, throat	1
202	193046	NUT, packing	1
203*	192692	V-PACKING, throat, V-Max™ UHMWPE, blue	3
204*	15C987	GLAND, male, throat	1
205	287551	CYLINDER, pump	1
206*	105444	BALL, sst, 0.3125 in.	1
207*	114054	PACKING, o-ring	1
208*	192693	V-PACKING, piston V-Max™ UHMWPE, blue	3
210	239932	VALVE, piston	1
212†	239922	KIT, seat, carbide includes 214 and 227	1
213	15C785	VALVE, intake (foot)	1
214*†	105445	BALL, sst, 0.5000 in.	1
215	192624	GUIDE, ball	1
216*	118503	WIPER, piston	1
217*	178969	GLAND, female, piston	1
218*	178939	V-PACKING, leather, piston	2
219*	196880	GLAND, male	1
220	248209	SLEEVE, cylinder	1
221*	108526	O-RING, PTFE	2
222	248206	ROD, piston	1
223*	178940	V-PACKING, leather, throat	2
224*	15C988	GLAND, female	1
227*†	107079	PACKING, o-ring	1
228	192714	SPACER, throat, nut	1
229*	15C997	WASHER, backup	1
230††	15E802	FITTING, pump (not shown)	1
231	118494	O-RING, acetal	1
232††	15E807	TUBE, intake (not shown)	1

\* These parts are also included in Repair Kit 248212, which may be purchased separately.

† These parts are also included in Carbide Seat Kit 239922, which may be purchased separately.

†† These parts are included with pump 287512.

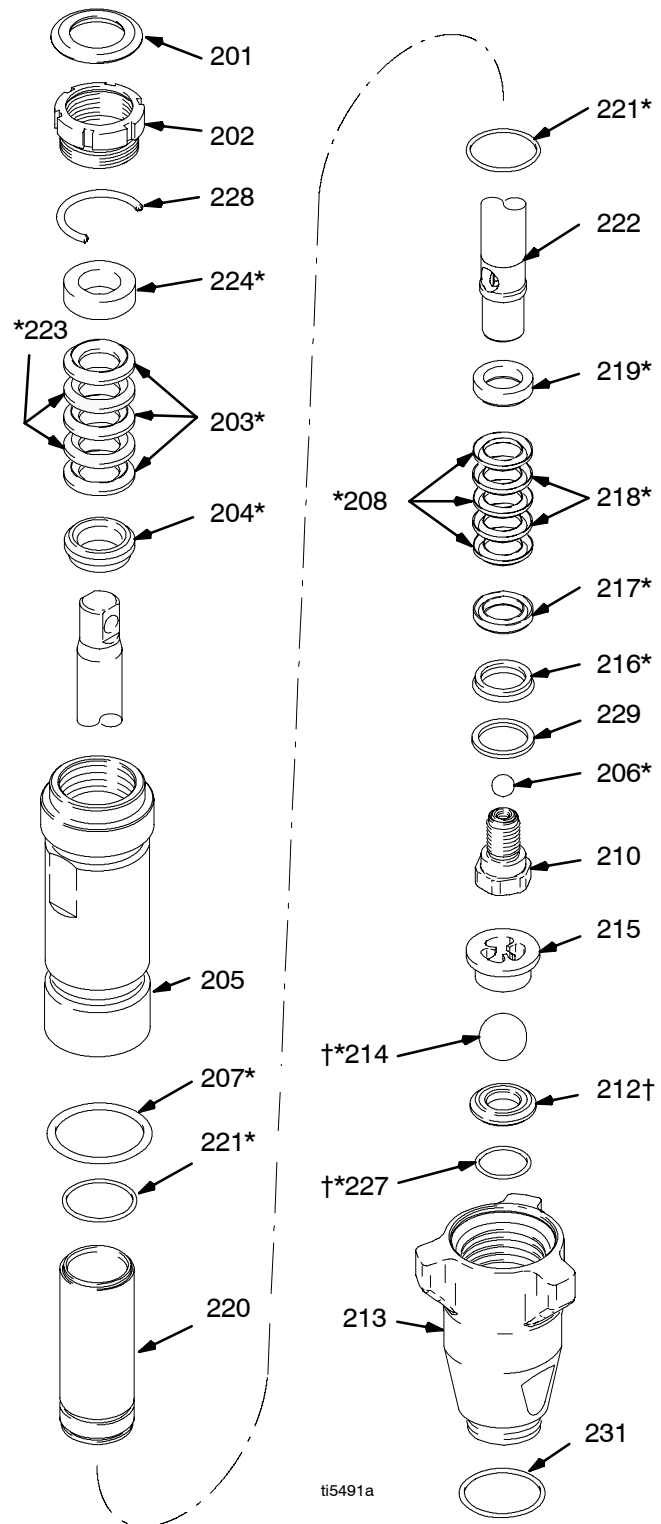

# Parts - Pump 287513

## Model 287513, Series A

Ref No.	Part No.	Description	Qty.
201	183171	PLUG	1
202	193032	NUT, packing	1
203*	193124	V-PACKING, throat, V-Max™ UHMWPE, blue	4
204*	15C989	GLAND, male, throat	1
205	287552	CYLINDER, pump	1
206*	101947	BALL, sst, 0.3125 in.	1
207*	106556	PACKING, o-ring	1
208*	193125	V-PACKING, piston V-Max™ UHMWPE, blue	4
210	240150	VALVE, piston	1
212†	244199	KIT, seat, carbide includes 214 and 227	1
213	15E654	VALVE, intake (foot)	1
214*†	102972	BALL, metallic	1
215	193027	GUIDE, ball	1
216*	118504	WIPER, piston	1
217*	183185	GLAND, female, piston	1
218*	15E329	V-PACKING, leather, piston	3
219*	183178	GLAND, male	1
220	248210	SLEEVE, cylinder	1
221*	107098	PACKING, o-ring	2
222	248207	ROD, piston	1
223*	183175	V-PACKING, leather, throat	3
224*	15C990	GLAND, packing	1
227*†	108526	PACKING, o-ring	1
228	193127	SPACER, nut	1
229*	15C998	WASHER, backup	1
230††	15E802	FITTING, pump (not shown)	1
231	118494	O-RING, acetal	1
232††	15E806	TUBE, intake (not shown)	1

\* These parts are also included in Repair Kit 248213, which may be purchased separately.

† These parts are also included in Carbide Seat Kit 244199, which may be purchased separately.

†† These parts are included with pump 287513.

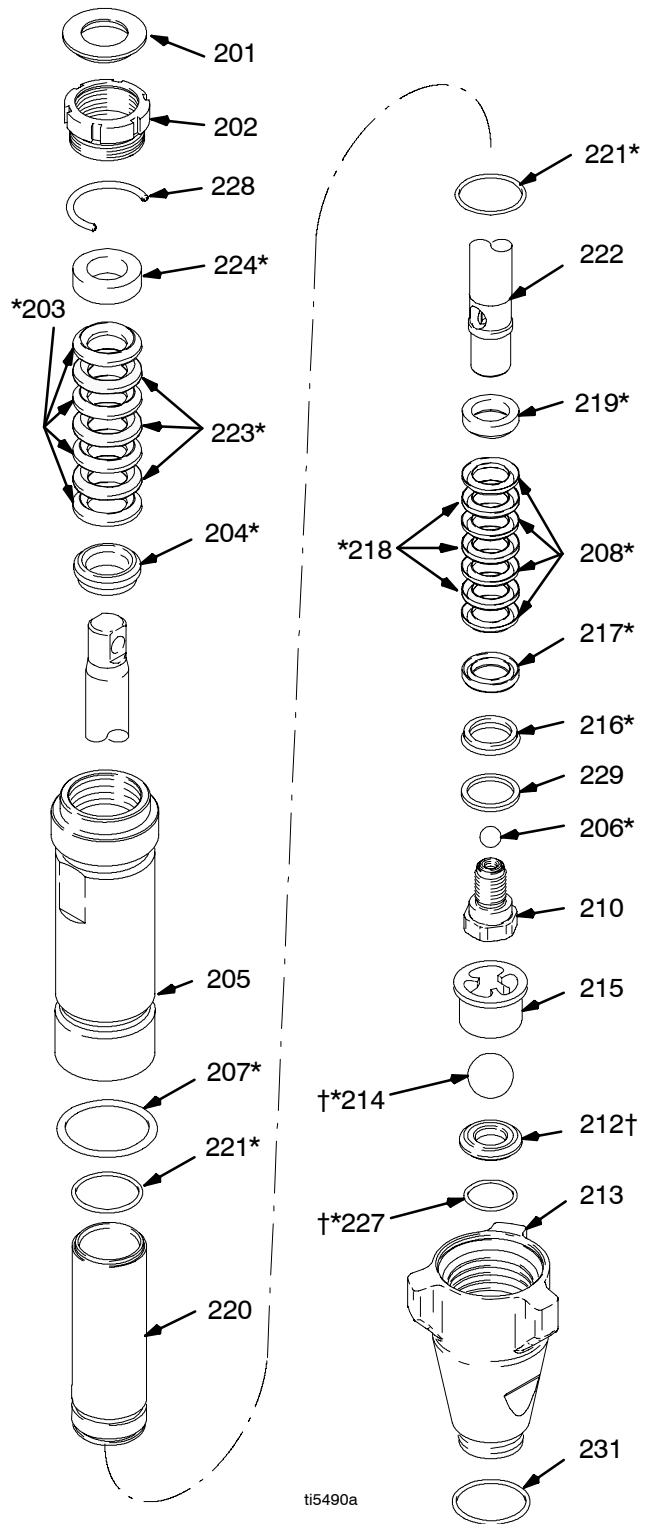

# Parts - Pump 249122

## Model 249122, Series A;

Ref No.	Part No.	Description	Qty.
201	112590	PLUG	1
202	15E962	NUT, packing	1
203*	193722	V-PACKING V-Max™ UHMWPE, blue	8
204*	198768	GLAND, packing, male, throat	1
205	249139	CYLINDER, pump	1
206*	107203	BALL, valve, check	1
207*	107306	PACKING, o-ring	1
210	249177	VALVE, piston	1
211	233698	SPRING, intake ball	1
212†	240918	KIT, SEAT, carbide includes 214 and 227	1
213	15E655	HOUSING, intake (foot)	1
214*†	107167	BALL, sst	1
215	198505	GUIDE, ball	1
216*	119636	WIPER, piston	1
217*	189588	GLAND, packing, female	1
218*	15E639	V-PACKING, piston, V-Max™ UHMWPE, brown	3
219*	189585	GLAND, packing, male	1
220	249121	SLEEVE, cylinder	1
221*	108822	PACKING, o-ring	2
222	249119	ROD, piston	1
223*	112591	V-PACKING, leather, throat	3
224*	194175	GLAND, packing, female	1
227*†	107098	PACKING, o-ring	1
228	108832	SPACER, nut	1
229*	15F183	WASHER, backup	1
230††	15E802	FITTING, pump (not shown)	1
231	118494	O-RING, acetal	1
232††	15E806	TUBE, intake (not shown)	1

\* These parts are also included in Repair Kit 249123, which may be purchased separately.

† These parts are also included in Carbide Seat Kit 240918, which may be purchased separately.

†† These parts are included with pump 249122.

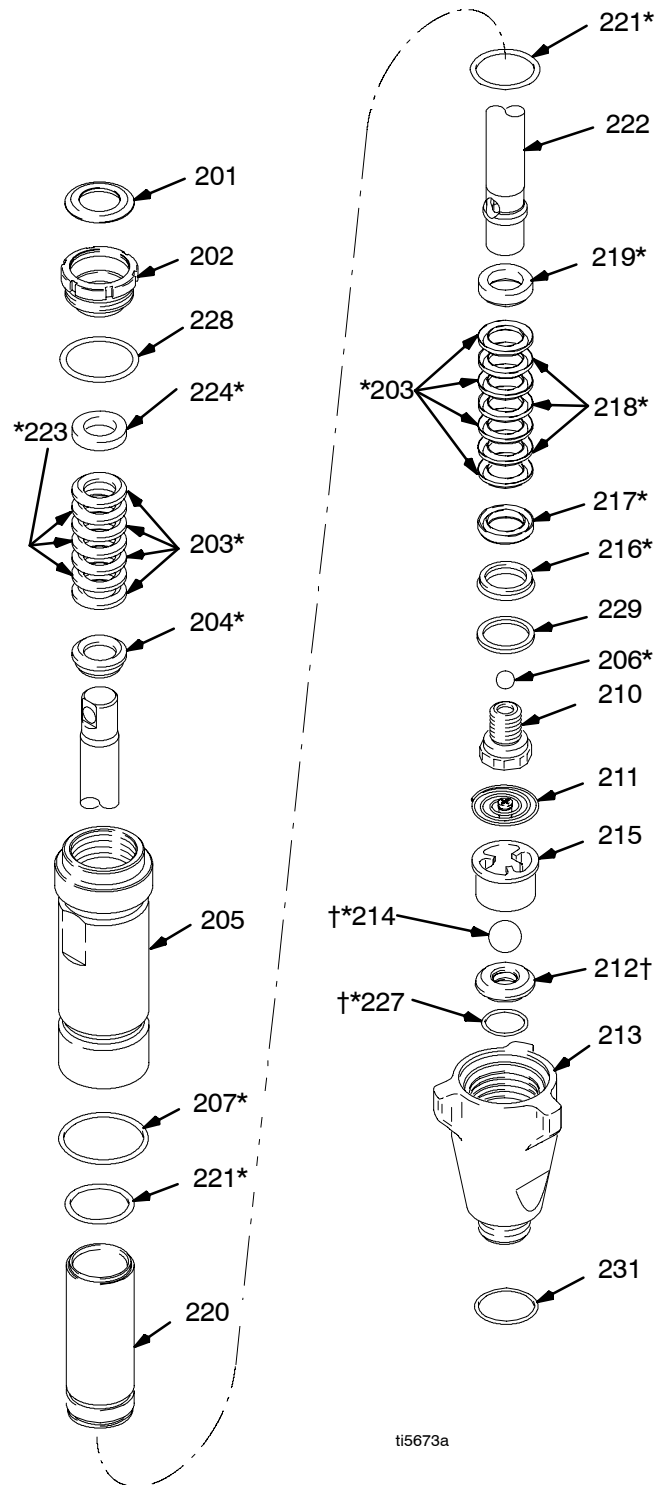

ti5673a

# Parts - Pump 287579

## Model 287579, Series A

Ref No.	Part No.	Description	Qty.
201	183171	PLUG	1
202	193032	NUT, packing	1
203*	193124	V-PACKING, throat, V-Max™ UHMWPE, blue	4
204*	15C989	GLAND, male, throat	1
205	287581	CYLINDER, pump	1
206*	101947	BALL, bearing	1
207*	106556	PACKING, o-ring	1
208*	193125	V-PACKING, piston V-Max™ UHMWPE, blue	4
210	240150	VALVE, piston	1
212†	244199	KIT, seat, carbide includes 214 and 227	1
213	196753	VALVE, intake (foot)	1
214*†	102972	BALL, metallic	1
215	196967	GUIDE, ball	1
216*	118504	WIPER, piston	1
217*	183185	GLAND, female, piston	1
218*	15E329	V-PACKING, leather, piston	3
219*	183178	GLAND, male	1
220	248210	SLEEVE, cylinder	1
221*	107098	PACKING, o-ring	2
222	249028	ROD, piston	1
223*	183175	V-PACKING, leather, throat	3
224*	15C990	GLAND, packing	1
227*†	108526	PACKING, o-ring	1
228	193127	SPACER, nut	1
229*	15C998	WASHER, backup	1
230††	15E802	FITTING, pump (not shown)	1

\* These parts are also included in Repair Kit 248213, which may be purchased separately.

† These parts are also included in Carbide Seat Kit 244199, which may be purchased separately.

†† These parts are included with pump 287579.

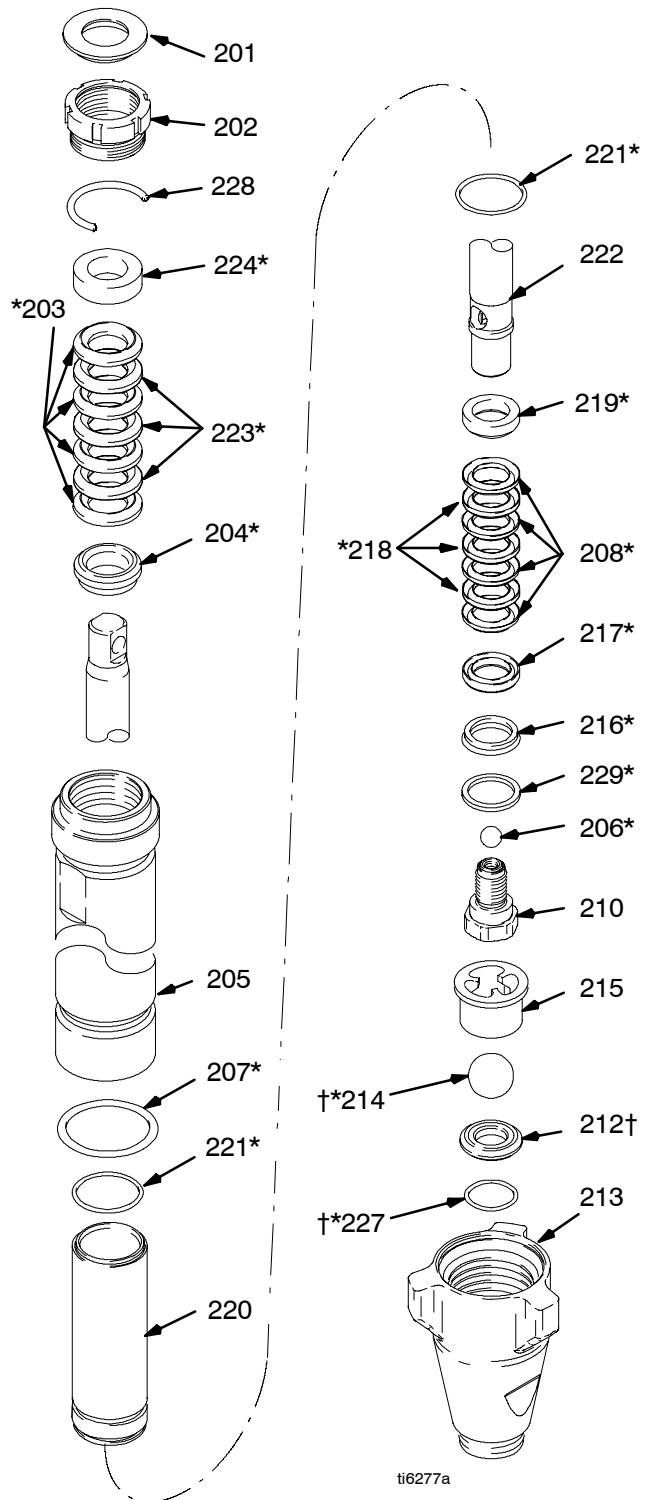

ti6277a

# Parts - Pump 287928

## Model 287928, Series A

Ref No.	Part No.	Description	Qty.
201	183171	PLUG	1
202	193032	NUT, packing	1
203*	193124	V-PACKING, throat, V-Max™ UHMWPE, blue	4
204*	15C989	GLAND, male, throat	1
205	287581	CYLINDER, pump	1
206*	116327	BALL, ceramic	1
207*	106556	PACKING, o-ring	1
208*	193125	V-PACKING, piston V-Max™ UHMWPE, blue	4
210	240150	VALVE, piston	1
212†	244571	KIT, seat, carbide includes 214 and 227	1
213	196753	VALVE, intake (foot)	1
214*†	111453	BALL, ceramic	1
215	196967	GUIDE, ball	1
216*	118504	WIPER, piston	1
217*	183185	GLAND, female, piston	1
218*	15E329	V-PACKING, leather, piston	3
219*	183178	GLAND, male	1
220	248210	SLEEVE, cylinder	1
221*	107098	PACKING, o-ring	2
222	249028	ROD, piston	1
223*	183175	V-PACKING, leather, throat	3
224*	15C990	GLAND, packing	1
227*†	108526	PACKING, o-ring	1
228	193127	SPACER, nut	1
229*	15C998	WASHER, backup	1
230††	15G880	FITTING, pump (not shown)	1

\* These parts are also included in Repair Kit 249189, which may be purchased separately.

† These parts are also included in Carbide Seat Kit 244571, which may be purchased separately.

†† These parts are included with pump 287928.

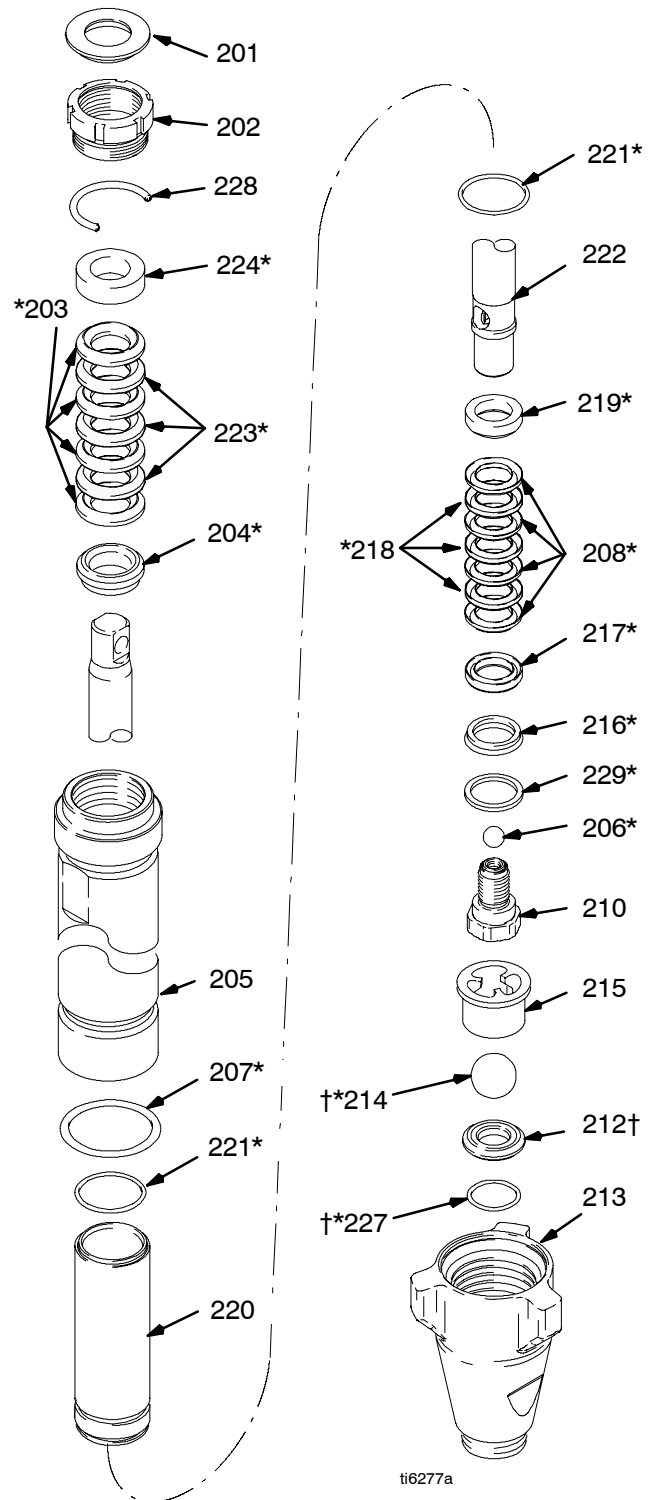

# Parts - Pump 287929

## Model 287929, Series A

Ref No.	Part No.	Description	Qty.
201	183171	PLUG	1
202	193032	NUT, packing	1
203*	193124	V-PACKING, throat, V-Max™ UHMWPE, blue	4
204*	15C989	GLAND, male, throat	1
205	287581	CYLINDER, pump	1
206*	101947	BALL, bearing	1
207*	106556	PACKING, o-ring	1
208*	193125	V-PACKING, piston V-Max™ UHMWPE, blue	4
210	240150	VALVE, piston	1
212†	244199	KIT, seat, carbide includes 214 and 227	1
213	196753	VALVE, intake (foot)	1
214*†	102972	BALL, metallic	1
215	196967	GUIDE, ball	1
216*	118504	WIPER, piston	1
217*	183185	GLAND, female, piston	1
218*	15E329	V-PACKING, leather, piston	3
219*	183178	GLAND, male	1
220	248210	SLEEVE, cylinder	1
221*	107098	PACKING, o-ring	2
222	249028	ROD, piston	1
223*	183175	V-PACKING, leather, throat	3
224*	15C990	GLAND, packing	1
227*†	108526	PACKING, o-ring	1
228	193127	SPACER, nut	1
229*	15C998	WASHER, backup	1
230††	15G880	FITTING, pump (not shown)	1

\* These parts are also included in Repair Kit 248213, which may be purchased separately.

† These parts are also included in Carbide Seat Kit 244199, which may be purchased separately.

†† These parts are included with pump 287929.

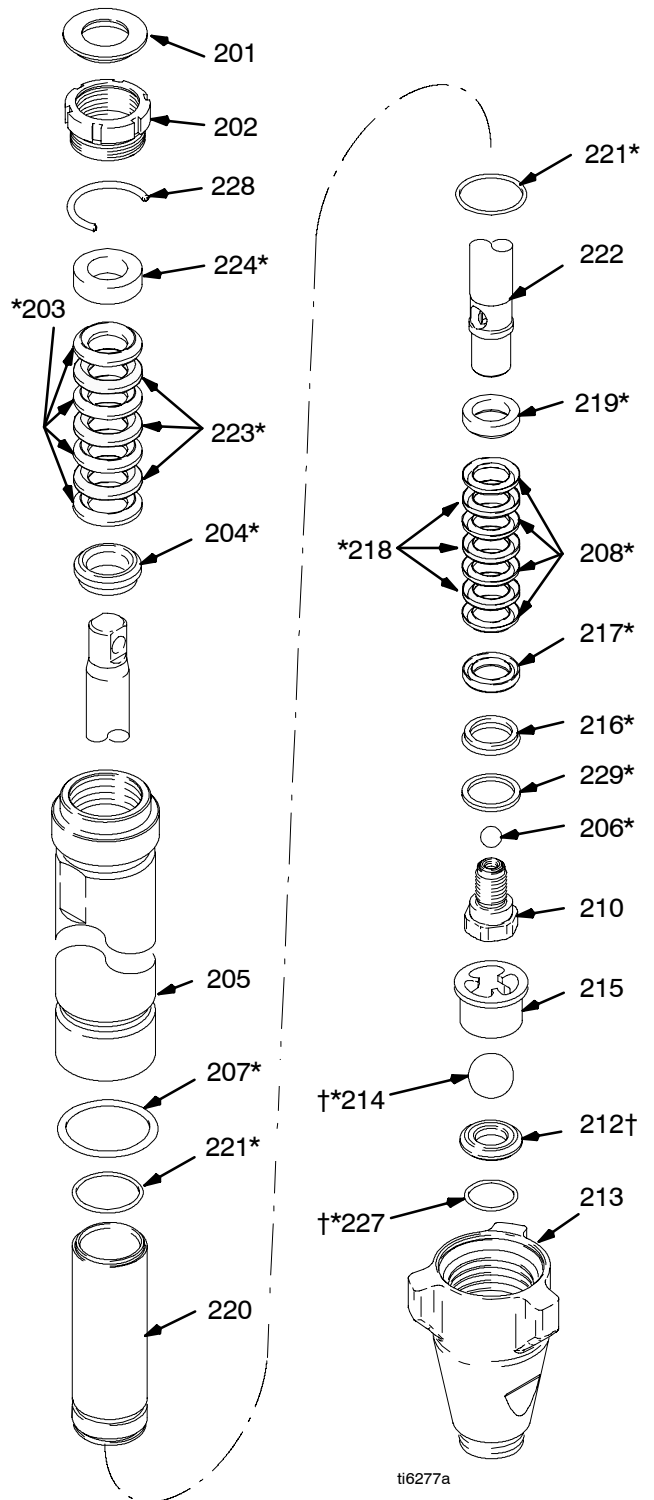

ti6277a

# Parts - Pump 289590

## Model 289590, Series A;

Ref No.	Part No.	Description	Qty.
201	112590	PLUG	1
202	15E962	NUT, packing	1
203*	193722	V-PACKING V-Max™ UHMWPE, blue	8
204*	198768	GLAND, packing, male, throat	1
205	15G437	CYLINDER, pump	1
206*	107203	BALL, valve, check	1
207*	107306	PACKING, o-ring	1
210	249177	VALVE, piston	1
211	233698	SPRING, intake ball	1
212†	240918	KIT, SEAT, carbide includes 214 and 227	1
213	15A303	HOUSING, intake (foot)	1
214*†	107167	BALL, sst	1
215	193391	GUIDE, ball	1
216*	119636	WIPER, piston	1
217*	189588	GLAND, packing, female	1
218*	15E639	V-PACKING, piston, V-Max™ UHMWPE, brown	3
219*	189585	GLAND, packing, male	1
220	249121	SLEEVE, cylinder	1
221*	108822	PACKING, o-ring	2
222	288103	ROD, piston	1
223*	112591	V-PACKING, leather, throat	3
224*	194175	GLAND, packing, female	1
227*†	107098	PACKING, o-ring	1
228	108832	PACKING, o-ring	1
229*	15J800	WASHER, backup	1
230††	15G509	FITTING, pump (not shown)	1
232††	C20195	PACKING, o-ring (not shown)	1

\* These parts are also included in Repair Kit 249123, which may be purchased separately.

† These parts are also included in Carbide Seat Kit 240918, which may be purchased separately.

†† These parts are included with pump 289590.

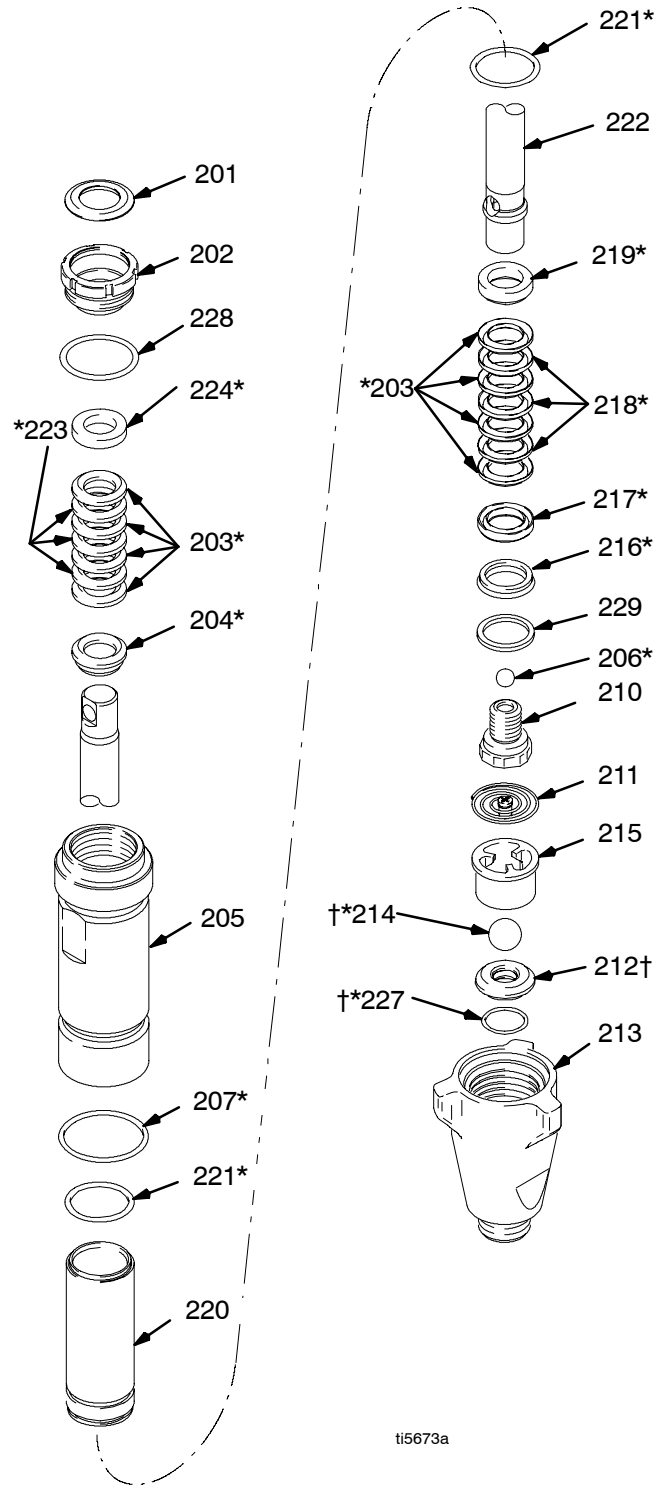

ti5673a





# Graco Standard Warranty

Graco warrants all equipment referenced in this document which is manufactured by Graco and bearing its name to be free from defects in material and workmanship on the date of sale to the original purchaser for use. With the exception of any special, extended, or limited warranty published by Graco, Graco will, for a period of twelve months from the date of sale, repair or replace any part of the equipment determined by Graco to be defective. This warranty applies only when the equipment is installed, operated and maintained in accordance with Graco's written recommendations.

This warranty does not cover, and Graco shall not be liable for general wear and tear, or any malfunction, damage or wear caused by faulty installation, misapplication, abrasion, corrosion, inadequate or improper maintenance, negligence, accident, tampering, or substitution of non-Graco component parts. Nor shall Graco be liable for malfunction, damage or wear caused by the incompatibility of Graco equipment with structures, accessories, equipment or materials not supplied by Graco, or the improper design, manufacture, installation, operation or maintenance of structures, accessories, equipment or materials not supplied by Graco.

This warranty is conditioned upon the prepaid return of the equipment claimed to be defective to an authorized Graco distributor for verification of the claimed defect. If the claimed defect is verified, Graco will repair or replace free of charge any defective parts. The equipment will be returned to the original purchaser transportation prepaid. If inspection of the equipment does not disclose any defect in material or workmanship, repairs will be made at a reasonable charge, which charges may include the costs of parts, labor, and transportation.

**THIS WARRANTY IS EXCLUSIVE, AND IS IN LIEU OF ANY OTHER WARRANTIES, EXPRESS OR IMPLIED, INCLUDING BUT NOT LIMITED TO WARRANTY OF MERCHANTABILITY OR WARRANTY OF FITNESS FOR A PARTICULAR PURPOSE.**

Graco's sole obligation and buyer's sole remedy for any breach of warranty shall be as set forth above. The buyer agrees that no other remedy (including, but not limited to, incidental or consequential damages for lost profits, lost sales, injury to person or property, or any other incidental or consequential loss) shall be available. Any action for breach of warranty must be brought within two (2) years of the date of sale.

**GRACO MAKES NO WARRANTY, AND DISCLAIMS ALL IMPLIED WARRANTIES OF MERCHANTABILITY AND FITNESS FOR A PARTICULAR PURPOSE, IN CONNECTION WITH ACCESSORIES, EQUIPMENT, MATERIALS OR COMPONENTS SOLD BUT NOT MANUFACTURED BY GRACO.** These items sold, but not manufactured by Graco (such as electric motors, switches, hose, etc.), are subject to the warranty, if any, of their manufacturer. Graco will provide purchaser with reasonable assistance in making any claim for breach of these warranties.

In no event will Graco be liable for indirect, incidental, special or consequential damages resulting from Graco supplying equipment hereunder, or the furnishing, performance, or use of any products or other goods sold hereto, whether due to a breach of contract, breach of warranty, the negligence of Graco, or otherwise.

## **FOR GRACO CANADA CUSTOMERS**

The parties acknowledge that they have required that the present document, as well as all documents, notices and legal proceedings entered into, given or instituted pursuant hereto or relating directly or indirectly hereto, be drawn up in English. Les parties reconnaissent avoir convenu que la rédaction du présente document sera en Anglais, ainsi que tous documents, avis et procédures judiciaires exécutés, donnés ou intentés à la suite de ou en rapport, directement ou indirectement, avec les procédures concernées.

# Graco Phone Number

**TO PLACE AN ORDER**, contact your Graco distributor, or call this number to identify the distributor closest to you:  
**1-800-690-2894 Toll Free**

*All written and visual data contained in this document reflect the latest product information available at the time of publication.  
Graco reserves the right to make changes at any time without notice.*

This manual contains English GN 310894 MM 310894

**Graco Headquarters:** Minneapolis  
**International Offices:** Belgium, China, Japan, Korea  
**GRACO INC. P.O. BOX 1441 MINNEAPOLIS, MN 55440-1441**  
www.graco.com  
2/2005, Rev 03/2008