

Repair



MAGNUMTM
by GRACO®

**Magnum Plus A20, Pro Plus A20, Pro Plus A30,
Pro Plus A45, and Pro Plus A60 Airless Sprayer**

332697C

EN

- For portable spray applications of architectural paints and coatings -

Models 16W108, 16E664, 16E665, 16W515, 17C243, 17C244, 17C245, 17C246



IMPORTANT SAFETY INSTRUCTIONS

Read all warnings and instructions in this manual.
Save these instructions.

See page 3 for model series information including dispense rate, recommended hose length, guns, and maximum working pressure.

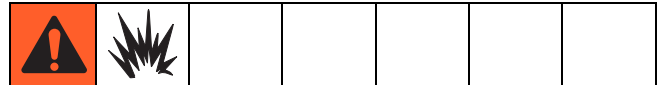

A20, A30, and A45 ONLY: Use water-based or mineral spirit-type materials only. Do not use materials having flash points lower than 100° F (38° C). This includes, but is not limited to, acetone, xylene, toluene, or naphtha. For more information about your material, request MSDS from distributor or retailer.

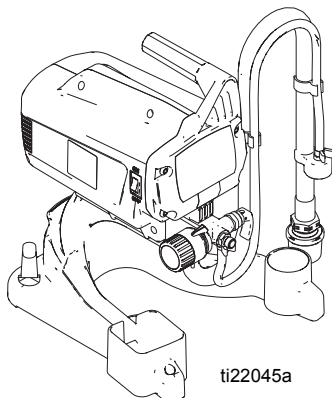

ti22045a

Pro Plus A20
Model: 16W108
Series A
Plus A20
Model: 17C243
Series A

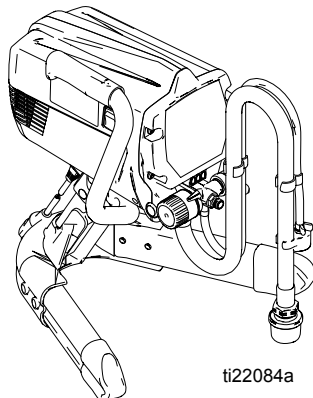

ti22084a

Pro Plus A30
Model: 16E664
Series A and B
Model: 17C244
Series A

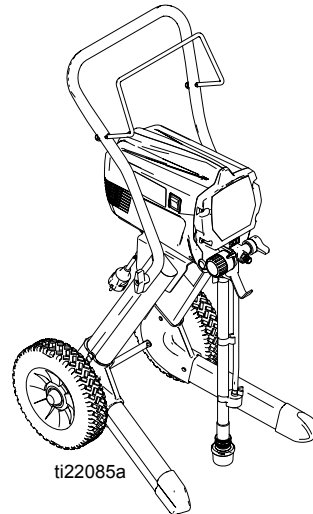

ti22085a

Pro Plus A45
Model: 16E665
Series A and B
Model: 17C245
Series A

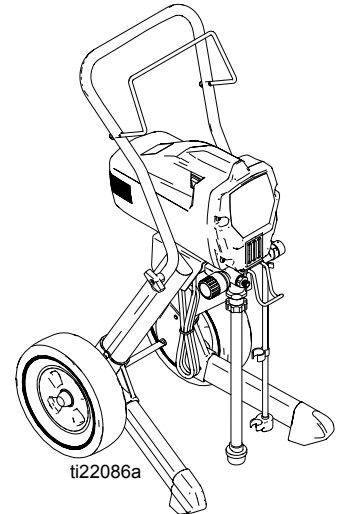

ti22086a

Pro Plus A60
Model: 16W515
Series A
Model: 17C246
Series A



Table of Contents

Specifications	3	Motor Diagnostics	27
Warnings	4	A20, A30, and A45	27
Component Identification A20 and A30	8	A60	27
Component Identification A45 and A60	10	Pressure Control Switch Diagnostics	28
Grounding and Electrical Requirements	12	Pump Diagnostics	28
Thermal Overload	12	Control Board Diagnostics	29
Operation	13	List of Kits	30
Trigger Lock	13	Parts	33
Pressure Relief Procedure	13	Wiring Diagram	53
General Repair Information	14	Technical Data	56
Basic Troubleshooting	15	Graco Standard Warranty	60
Advanced Troubleshooting	20		
Motor Does Not Operate	20		
Circuit Breaker is Tripping	23		
Erratic Motor Operation	24		
Low or Fluctuating Output	25		
Excessive Pressure Build Up	26		

Specifications

This equipment is not intended for use with flammable or combustible materials used in places such as cabinet shops or other “factory”, or fixed locations. If you intend to use this equipment in this type of application, you must comply with NFPA 33 and OSHA requirements for the use of flammable and combustible materials.

Model Name	Series	Maximum Dispense Rate lpm (gpm)	Hose Length and Diameter	Gun Model	Maximum Working Pressure		
					bar	MPa	PSI
A20	A	0.91 lpm (0.24 gpm)	6.4 mm x 7.5 m (1/4 in. x 25 ft)	SG2	207	21	3000
A30	A and B	1.02 lpm (0.27 gpm)	6.4 mm x 7.5 m (1/4 in. x 25 ft)	SG3	207	21	3000
A45	A and B	1.17 lpm (0.31 gpm)	6.4 mm x 15 m (1/4 in. x 50 ft)	SG3	207	21	3000
A60	A	1.44 lpm (0.38 gpm)	6.4 mm x 15 m (1/4 in. x 50 ft)	SG3	207	21	3000

Warnings

The following warnings are for the setup, use, grounding, maintenance, and repair of this equipment. The exclamation point symbol alerts you to a general warning and the hazard symbols refer to procedure-specific risks. When these symbols appear in the body of this manual or on warning labels, refer back to these Warnings. Product-specific hazard symbols and warnings not covered in this section may appear throughout the body of this manual where applicable.

WARNING



GROUNDING

This product must be grounded. In the event of an electrical short circuit, grounding reduces the risk of electric shock by providing an escape wire for the electric current. This product is equipped with a cord having a grounding wire with an appropriate grounding plug. The plug must be plugged into an outlet that is properly installed and grounded in accordance with all local codes and ordinances.

- Improper installation of the grounding plug is able to result in a risk of electric shock.
- When repair or replacement of the cord or plug is required, do not connect the grounding wire to either flat blade terminal.
- The wire with insulation having an outer surface that is green with or without yellow stripes is the grounding wire.
- Check with a qualified electrician or serviceman when the grounding instructions are not completely understood, or when in doubt as to whether the product is properly grounded.
- Do not modify the plug provided; if it does not fit the outlet, have the proper outlet installed by a qualified electrician.
- This product is for use on a nominal 230V circuit and has a grounding plug similar to the plugs illustrated in the figure below.

230V

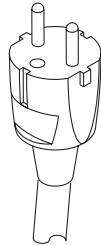

- Only connect the product to an outlet having the same configuration as the plug.
- Do not use an adapter with this product.

Extension Cords:

- Use only a 3-wire extension cord that has a grounding plug and a grounding receptacle that accepts the plug on the product.
- Make sure your extension cord is not damaged. If an extension cord is necessary, use 12 AWG (2.5 mm²) minimum to carry the current that the product draws.
- An undersized cord results in a drop in line voltage and loss of power and overheating.

! WARNING

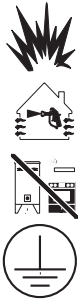

FIRE AND EXPLOSION HAZARD

Flammable fumes, such as solvent and paint fumes, in work area can ignite or explode. To help prevent fire and explosion:

- Do not spray flammable or combustible materials near an open flame or sources of ignition such as cigarettes, motors, and electrical equipment. **For A20, A30, and A45 models:** only use water-based or mineral spirit-type materials with a flash point greater than 100° F (38° C).
- Do not spray combustible materials near an open flame or sources of ignition such as cigarettes, motors, and electrical equipment.
- Paint or solvent flowing through the equipment is able to result in static electricity. Static electricity creates a risk of fire or explosion in the presence of paint or solvent fumes. All parts of the spray system, including the pump, hose assembly, spray gun, and objects in and around the spray area shall be properly grounded to protect against static discharge and sparks. Use Graco conductive or grounded high-pressure airless paint sprayer hoses.
- Verify that all containers and collection systems are grounded to prevent static discharge. Do not use pail liners unless they are antistatic or conductive.
- Connect to a grounded outlet and use grounded extensions cords. Do not use a 3-to-2 adapter.
- Do not use a paint or a solvent containing halogenated hydrocarbons.
- Keep spray area well-ventilated. Keep a good supply of fresh air moving through the area. Keep pump assembly in a well ventilated area. Do not spray pump assembly.
- Do not smoke in the spray area.
- Do not operate light switches, engines, or similar spark producing products in the spray area.
- Keep area clean and free of paint or solvent containers, rags, and other flammable materials.
- Know the contents of the paints and solvents being sprayed. Read all Material Safety Data Sheets (MSDS) and container labels provided with the paints and solvents. Follow the paint and solvents manufacturer's safety instructions.
- Fire extinguisher equipment shall be present and working.
- Sprayer generates sparks. When combustible materials are used in or near the sprayer or for flushing or cleaning, keep sprayer at least 20 feet (6 m) away from explosive vapors.











SKIN INJECTION HAZARD



High-pressure spray is able to inject toxins into the body and cause serious bodily injury. In the event that injection occurs, **get immediate surgical treatment.**

- Do not aim the gun at, or spray any person or animal.
- Keep hands and other body parts away from the discharge. For example, do not try to stop leaks with any part of the body.
- Always use the nozzle tip guard. Do not spray without nozzle tip guard in place.
- Use Graco nozzle tips.
- Use caution when cleaning and changing nozzle tips. In the case where the nozzle tip clogs while spraying, follow the **Pressure Relief Procedure** for turning off the unit and relieving the pressure before removing the nozzle tip to clean.
- Do not leave the unit energized or under pressure while unattended. When the unit is not in use, turn off the unit and follow the **Pressure Relief Procedure** for turning off the unit.
- Check hoses and parts for signs of damage. Replace any damaged hoses or parts.
- This system is capable of producing 3000 psi. Use Graco replacement parts or accessories that are rated a minimum of 3000 psi.
- Always engage the trigger lock when not spraying. Verify the trigger lock is functioning properly.
- Verify that all connections are secure before operating the unit.
- Know how to stop the unit and bleed pressure quickly. Be thoroughly familiar with the controls.

! WARNING

 	<p>EQUIPMENT MISUSE HAZARD Misuse can cause death or serious injury.</p> <ul style="list-style-type: none"> • Do not operate the unit when fatigued or under the influence of drugs or alcohol. • Do not exceed the maximum working pressure or temperature rating of the lowest rated system component. See Technical Data in all equipment manuals. • Use fluids and solvents that are compatible with equipment wetted parts. See Technical Data in all equipment manuals. Read fluid and solvent manufacturer's warnings. For complete information about your material, request MSDS from distributor or retailer. • Do not leave the work area while equipment is energized or under pressure. • Turn off all equipment and follow the Pressure Relief Procedure when equipment is not in use. • Check equipment daily. Repair or replace worn or damaged parts immediately with genuine manufacturer's replacement parts only. • Do not alter or modify equipment. Alterations or modifications may void agency approvals and create safety hazards. • Make sure all equipment is rated and approved for the environment in which you are using it. • Use equipment only for its intended purpose. Call your distributor for information. • Route hoses and cables away from traffic areas, sharp edges, moving parts, and hot surfaces. • Do not kink or over bend hoses or use hoses to pull equipment. • Keep children and animals away from work area. • Comply with all applicable safety regulations.
 	<p>ELECTRIC SHOCK HAZARD This equipment must be grounded. Improper grounding, setup, or usage of the system can cause electric shock.</p> <ul style="list-style-type: none"> • Turn off and disconnect power cord before servicing equipment. • Connect only to grounded electrical outlets. • Use only 3-wire extension cords. • Ensure ground prongs are intact on power and extension cords. • Do not expose to rain. Store indoors.
	<p>PRESSURIZED ALUMINUM PARTS HAZARD Use of fluids that are incompatible with aluminum in pressurized equipment can cause serious chemical reaction and equipment rupture. Failure to follow this warning can result in death, serious injury, or property damage.</p> <ul style="list-style-type: none"> • Do not use 1,1,1-trichloroethane, methylene chloride, other halogenated hydrocarbon solvents or fluids containing such solvents. • Many other fluids may contain chemicals that can react with aluminum. Contact your material supplier for compatibility.
	<p>BURN HAZARD Equipment surfaces and fluid that is heated can become very hot during operation. To avoid severe burns:</p> <ul style="list-style-type: none"> • Do not touch hot fluid or equipment.
 	<p>MOVING PARTS HAZARD Moving parts can pinch, cut or amputate fingers and other body parts.</p> <ul style="list-style-type: none"> • Keep clear of moving parts. • Do not operate equipment with protective guards or covers removed. • Pressurized equipment can start without warning. Before checking, moving, or servicing equipment, follow the Pressure Relief Procedure and disconnect all power sources.

! WARNING

	<p>TOXIC FLUID OR FUMES HAZARD</p> <p>Toxic fluids or fumes can cause serious injury or death if splashed in the eyes or on skin, inhaled, or swallowed.</p> <ul style="list-style-type: none"> • Read MSDSs to know the specific hazards of the fluids you are using. • Store hazardous fluid in approved containers, and dispose of it according to applicable guidelines.
	<p>PERSONAL PROTECTIVE EQUIPMENT</p> <p>Wear appropriate protective equipment when in the work area to help prevent serious injury, including eye injury, hearing loss, inhalation of toxic fumes, and burns. This protective equipment includes but is not limited to:</p> <ul style="list-style-type: none"> • Protective eyewear, and hearing protection. • Respirators, protective clothing, and gloves as recommended by the fluid and solvent manufacturer.
	<p>CALIFORNIA PROPOSITION 65</p> <p>This product contains a chemical known to the State of California to cause cancer, birth defects or other reproductive harm. Wash hands after handling.</p>

Component Identification A20 and A30

A	Airless spray gun	Dispenses fluid.
B	Power switch	Turns sprayer ON and OFF.
C	Pressure control knob	Increases (clockwise) and decreases (counter-clockwise) fluid pressure in pump, hose, and spray gun.
C1	Setting Indicator	To select function, align symbol on pressure control knob with setting indicator, page 13.
D	Pump fluid outlet fitting	Threaded connection for paint hose.
G	Suction tube	Draws fluid from paint pail into pump.
H	Prime tube (with diffuser)	Drains fluid in system during priming and pressure relief.
J	Prime/Spray valve	<ul style="list-style-type: none"> • PRIME position directs fluid to prime tube. • SPRAY position directs pressurized fluid to paint hose. • Automatically relieves system pressure in overpressure situations.
L	Inlet screen	Prevents debris from entering pump.
M	Paint hose	Transports high-pressure fluid from pump to spray gun.
N	Handle	Used to help transport sprayer.
Q	Tip guard	Reduces risk of fluid injection injury.
R	Reversible spray tip	<ul style="list-style-type: none"> • Atomizes fluid being sprayed, forms spray pattern and controls fluid flow according to hole size. • Reverse unclogs plugged tips without disassembly.
S	Gun trigger safety lever (page 13)	Prevents accidental triggering of spray gun.
T	Gun fluid inlet fitting	Threaded connection for paint hose.
U	Power Flush attachment	Connects garden hose to suction tube for power flushing water-based fluids.
V	Gun fluid filter	Filters fluid entering spray gun to reduce tip clogs.
W	Pail hanger (A20 sprayer only)	For transporting pail by its handle.
X	Power cord	Supplies sprayer with electricity
Z	Pump priming button (A30 sprayer only)	Manually taps inlet ball to loosen if stuck.
AA	Garden Hose Adapter	Connects to Power Flush Attachment and garden hose.

Component Identification A20 and A30 (A20 shown)

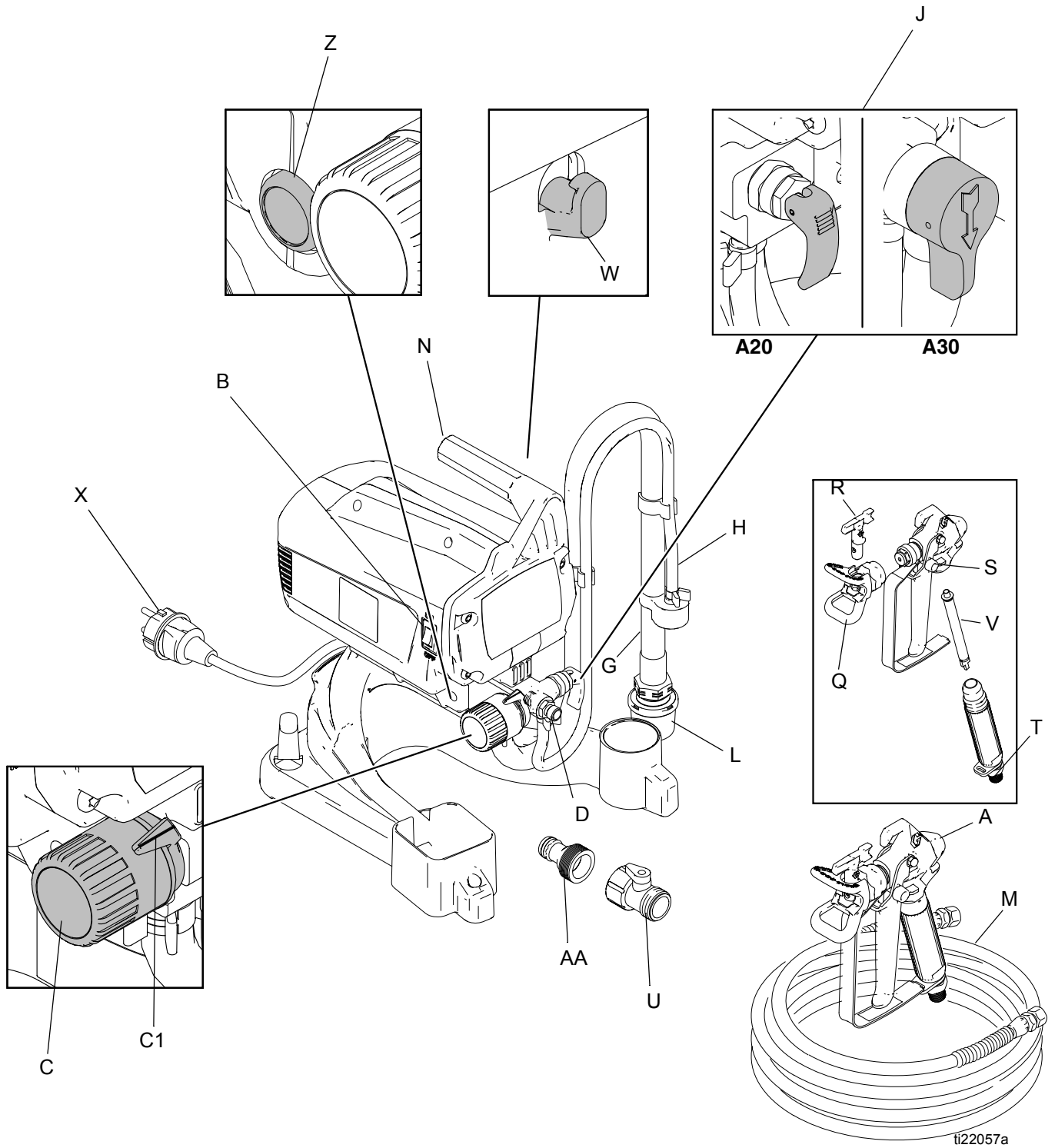

Component Identification A45 and A60

A	Airless spray gun	Dispenses fluid.
B	Power switch	Turns sprayer ON and OFF.
C	Pressure control knob	Increases (clockwise) and decreases (counter-clockwise) fluid pressure in pump, hose, and spray gun.
C1	Setting Indicator	To select function, align symbol on pressure control knob with setting indicator, page 13.
D	Pump fluid outlet fitting	Threaded connection for paint hose.
E	InstaClean™ fluid filter (A60 Sprayer Only)	<ul style="list-style-type: none"> Filters fluid coming out of pump to reduce tip plugging and improve finish. Self cleans only during pressure relief.
F	Power-Piston™ Pump, (Not shown. Behind Easy Access door) (A60 Sprayer Only)	Pumps and pressurizes fluid and delivers it to paint hose.
F1	Easy Access door (A60 Sprayer Only)	Easy Access door permits quick access to outlet valve. To remove door, insert flat blade of screwdriver into slot on the bottom of the door (as shown on page, 11).
G	Suction tube	Draws fluid from paint pail into pump.
H	Prime tube (with diffuser)	Drains fluid in system during priming and pressure relief.
J	Prime/Spray valve	<ul style="list-style-type: none"> PRIME position directs fluid to prime tube. SPRAY position directs pressurized fluid to paint hose. Automatically relieves system pressure in overpressure situations.
K	Ball Knocker (A60 Sprayer Only)	Automatically taps the inlet ball when you turn the sprayer on.
L	Inlet screen	Prevents debris from entering pump.
M	Paint hose	Transports high-pressure fluid from pump to spray gun.
Q	Tip guard	Reduces risk of fluid injection injury.
R	Reversible spray tip	<ul style="list-style-type: none"> Atomizes fluid being sprayed, forms spray pattern and controls fluid flow according to hole size. Reverse unclogs plugged tips without disassembly.
S	Gun trigger safety lever (page 13)	Prevents accidental triggering of spray gun.
T	Gun fluid inlet fitting	Threaded connection for paint hose.
U	Power Flush attachment	Connects garden hose to suction tube for power flushing water-based fluids.
V	Gun fluid filter	Filters fluid entering spray gun to reduce tip clogs.
W	Hose wrap Rack	Stows paint hose.
X	Pail hanger	For transporting pail by its handle.
Y	Power Cord	Supplies sprayer with electricity.
Z	Power Flush Adapter (A60 Sprayer Only)	Adapts suction tube (G) to Power Flush attachment (U).
AA	Pump Priming Button (A45 sprayer only)	Manually taps inlet ball to loosen if stuck.
AB	Garden Hose Adapter	Connects to Power Flush Attachment and garden hose.

Component Identification A45 and A60 (A60 shown)

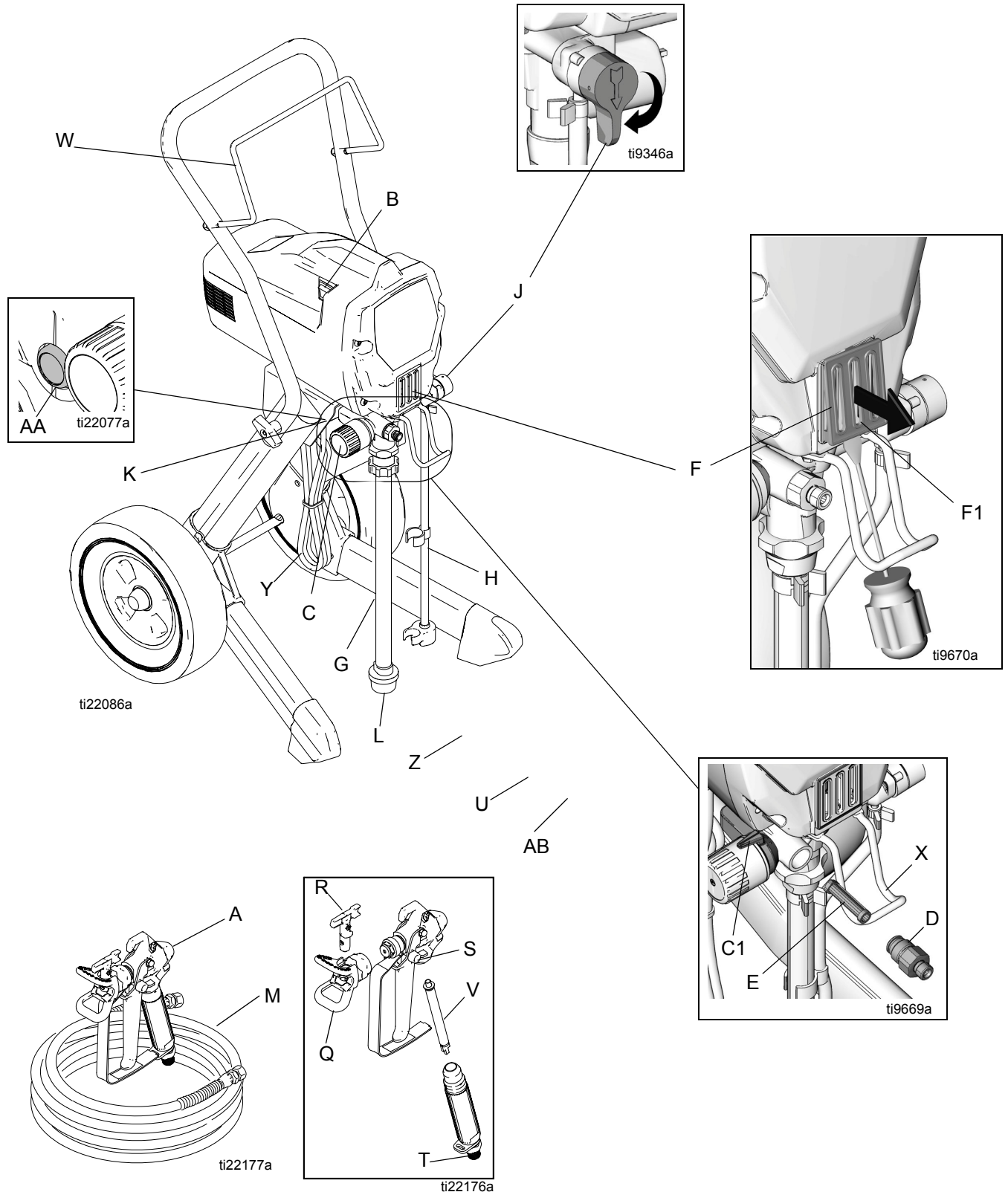

Grounding and Electrical Requirements



Sprayer must be grounded. Grounding reduces the risk of static and electric shock by providing an escape wire for electrical current due to static build up or in the event of a short circuit.

- The 240 VAC sprayers require a 220-240 VAC, 50/60 Hz, 10A circuit with a grounding receptacle.
- Never use an outlet that is not grounded or an adapter.
- Do not use the sprayer if the electrical cord has a damaged ground prong.
- Only use an extension cord with an undamaged 3-prong plug.

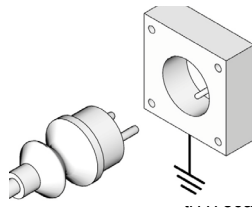

Recommended extension cords for use with this sprayer:

- 15 m (49.2 ft) 1.0 mm²
- 30 m (98.4 ft) 1.5 mm²
- 50 m (164.0 ft) 2.5 mm²

Spray gun: ground through connection to a properly grounded fluid hose and pump.

NOTE: Smaller gauge or longer extension cords may reduce sprayer performance.

Fluid supply container: follow local code.

Solvent pails used when flushing: follow local code. Use only conductive metal pails, placed on a grounded surface such as concrete. Do not place the pail on a nonconductive surface, such as paper or cardboard, which interrupts grounding continuity.

Grounding the metal pail: connect a ground wire to the pail by clamping one end to pail and other end to ground such as a water pipe.

Maintaining grounding continuity: when flushing or relieving pressure hold metal part of the spray gun firmly to the side of a grounded metal pail, then trigger the gun.

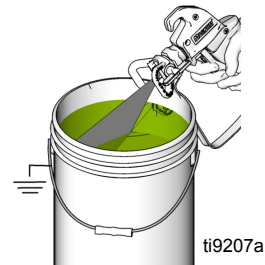

Thermal Overload

Motor has a thermal overload switch to shut itself down if overheated. If unit overheats, allow approximately 45 minutes for unit to cool. Once cool, switch will close and unit will restart.

!						
<p>To reduce risk of injury from motor starting unexpectedly when it cools, always turn power switch OFF if motor shuts down.</p>						

Operation

See **Operation** manual for basic information on sprayer setup, flushing, and storage.

Trigger Lock

Always engage the trigger lock when you stop spraying to prevent the gun from being triggered accidentally by hand or if dropped or bumped.

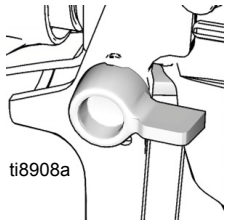

Trigger Locked

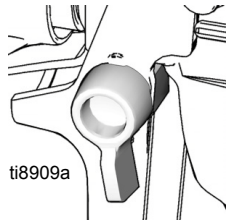

Trigger Unlocked

Pressure Relief Procedure

Follow this **Pressure Relief Procedure** whenever you stop spraying and before cleaning, checking, servicing, or transporting equipment.



1. Turn power switch OFF and unplug power cord.

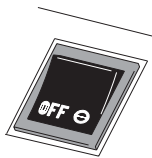

ti2810a

2. Move Prime/Spray valve to PRIME to relieve pressure.

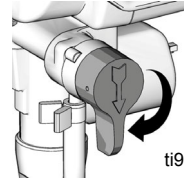

ti9346a

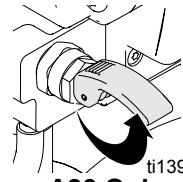

ti13961a

A20 Only

3. Hold gun firmly to side of pail. Trigger the gun to relieve pressure.

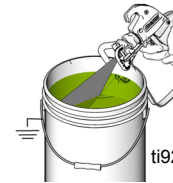

ti9207a

4. Engage trigger lock.

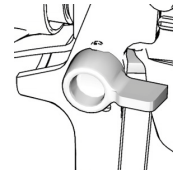

ti8908a

NOTE: Leave Prime/Spray valve in the PRIME position until you are ready to spray again.

If you suspect the spray tip or hose is clogged or that pressure has not been fully relieved after following the steps above, **VERY SLOWLY** loosen tip guard retaining nut or hose end coupling to relieve pressure gradually, then loosen completely. Clear hose or tip obstruction. See Unclogging Spray Tip in the **Operation** manual.

Pressure Control Knob Settings



High Pressure Spray



Low Pressure Spray



Prime / Clean







Rolling



ti5597a

NOTE: To select function, align symbol on pressure control knob with setting indicator on sprayer.

General Repair Information

						
<p>Flammable materials spilled on hot, bare, motor could cause fire or explosion. To reduce risk of burns, fire or explosion, do not operate sprayer with cover removed.</p>						

- Keep all screws, nuts, washers, gaskets, and electrical fittings removed during repair procedures. These parts usually are not provided with replacement kits.
- Test repairs after problems are corrected.
- If sprayer does not operate properly, review repair procedure to verify you did it correctly. See **Basic Troubleshooting**, page 15 and **Advanced Troubleshooting**, page 20.
- Overspray may build up in the air passages. Remove any overspray and residue from air passages and openings in the enclosures whenever you service sprayer.
- Do not operate the sprayer without the cover in place. Replace if damaged. Covers direct cooling air around motor to prevent overheating.

						
<p>To reduce risk of serious injury, including electric shock:</p> <ul style="list-style-type: none"> • Do not touch moving or electric parts with fingers or tools while testing repair. • Unplug sprayer when power is not required for testing. • Install all covers, gaskets, screws and washers before you operate sprayer. 						

NOTICE						
<ul style="list-style-type: none"> • Do not run sprayer dry for more than 30 seconds. Doing so could damage pump packings. • Protect the internal drive parts of this sprayer from water. Openings in the cover allow for air cooling of the mechanical parts and electronics inside. If water gets in these openings, the sprayer could malfunction or be permanently damaged. • Prevent pump corrosion and damage from freezing. Never leave water or water-base paint in sprayer when its not in use in cold weather. Freezing fluids can seriously damage sprayer. Store sprayer with Pump Armor to protect sprayer during storage. 						

Basic Troubleshooting

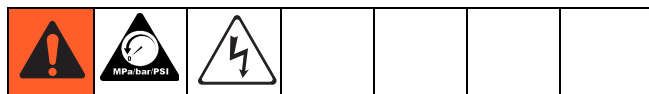

Check everything in this Basic Troubleshooting table before you bring the sprayer to a Graco/MAGNUM authorized service center.

Problem	Cause	Solution
Power switch is on and sprayer is plugged in, but motor does not run, and pump does not cycle.	Pressure is set at zero pressure.	Turn pressure control knob clockwise to increase pressure setting.
	Motor or control is damaged.	Take sprayer to Graco/MAGNUM authorized service center.
	Electric outlet is not providing power.	<ul style="list-style-type: none"> Try a different outlet or plug in something that you know is working to test outlet. Reset building circuit breaker or replace fuse.
	Extension cord is damaged.	Replace extension cord. Read Grounding and Electrical Requirements , page 12.
	Sprayer power cord is damaged.	Check for broken insulation or wires. Replace power cord if damaged.
	Paint and/or water is frozen or hardened in pump.	<p>Unplug sprayer from outlet. If frozen do NOT try to start sprayer until it is completely thawed or you may damage the motor, control board and/or drivetrain.</p> <p>Make sure power switch is OFF. Place sprayer in a warm area for several hours. Then plug in power cord and turn sprayer ON. Slowly increase pressure setting to see if motor will start.</p> <p>If paint is hardened in sprayer, pump packings, valves, drivetrain or pressure switch may need to be replaced. Take sprayer to Graco/MAGNUM authorized service center.</p>

Problem	Cause	Solution
Pump does not prime.	Prime/Spray Valve is in SPRAY position.	Move Prime/Spray Valve to PRIME position.
	Inlet screen is clogged or suction tube is not immersed in fluid.	Clean debris off inlet screen and make sure suction tube is immersed in fluid.
	Pump was not primed with flushing fluid.	Remove suction tube from paint. Prime pump with water or solvent-based flushing fluid, see Operation manual.
	Inlet valve check ball is stuck.	Remove suction tube and place a pencil into the inlet section to dislodge the ball, press pump priming button, or Power Flush sprayer. See Operation manual. A60: AutoPrime may need replacement. Turn power switch ON and listen for “tap” in pump. If you do not hear “tap”, AutoPrime is damaged. Take sprayer to Graco/MAGNUM authorized service center.
	Inlet valve check ball or seat is dirty or worn.	Remove inlet fitting. Clean or replace ball and seat.
	Outlet valve check ball is stuck or worn.	A60: Insert screw driver in slot and remove Easy-Access™ door, page 11. Unscrew outlet valve with a 3/4 in. socket. Remove and clean assembly. Replace if worn. A20, A30, and A45: Remove outlet fitting and clean outlet check ball. Replace if worn.
	Suction tube is leaking.	Tighten suction tube connection. Inspect for cracks or vacuum leaks.
	Pump does not prime with fluid.	Remove suction tube from paint. Prime pump with water or solvent-based flushing fluid.
	Fluids are viscous or sticky.	Some fluids may prime faster if the Power Switch is momentarily turned off so the pump can slow and stop. Repeat several times if necessary.

Problem	Cause	Solution
Pump cycles but does not build up pressure.	Pump is not primed.	Prime pump.
	Inlet screen is clogged.	Clean debris off inlet screen and make sure suction tube is immersed in fluid.
	Suction tube is not immersed in paint.	Make sure suction tube is immersed in paint.
	Suction tube is leaking.	Tighten suction tube connection. Inspect for cracks or vacuum leaks. If cracked or damaged, replace suction tube.
	Prime/Spray Valve is worn or obstructed with debris.	Take sprayer to Graco/MAGNUM authorized service center.
	Pump check ball is stuck.	Read <i>Pump does not prime</i> section in Basic Troubleshooting , page 15.
Pump cycles, but paint only dribbles or spurts when spray gun is triggered.	Pressure is set too low.	Slowly turn Pressure Control Knob clockwise to increase pressure setting which will turn motor on to build pressure.
	Spray tip is clogged.	Unclog spray tip, see Operation manual.
	InstaClean™ fluid filter is clogged.	Clean or replace InstaClean™ fluid filter, see Operation manual.
	Spray gun fluid filter is clogged.	Clean or replace gun fluid filter, see Operation manual.
	Spray tip is too large or worn.	Replace tip.

Problem	Cause	Solution
Pressure is set at maximum but cannot achieve a good spray pattern.	Reversible spray tip is in UNCLOG position.	Rotate arrow-shaped handle on spray tip so it points forward in SPRAY position, see Operation manual.
	Spray tip is too large for sprayer.	Select smaller spray tip.
	Spray tip is worn beyond capability of sprayer.	Replace spray tip.
	Extension cord is too long or not heavy enough gauge.	Replace extension cord. See Grounding and Electrical Requirements , page 12.
	Spray gun fluid filter is clogged.	Clean or replace spray gun fluid filter, see Operation manual.
	InstaClean™ fluid filter is clogged.	Clean or replace InstaClean™ fluid filter, see Operation manual.
	Inlet screen is clogged.	Clean debris off inlet screen.
	Pump valves are worn, or debris is clogging valve.	Check for worn pump valves. <ul style="list-style-type: none"> a. Prime sprayer with paint. b. Trigger gun momentarily. When trigger is released, pump should cycle momentarily and stop. If pump continues to cycle, pump valves may be worn. c. Remove valves and check for debris.
	Material is too thick.	Thin material.
	Hose is too long (if extra section is added).	Remove section of hose.
Spray gun stopped spraying.	Suction tube is leaking.	Tighten suction tube connection. Inspect for cracks or vacuum leaks.
	Spray tip is clogged.	Unclog spray tip, see Operation manual.
When paint is sprayed, it runs down the wall or sags.	Coat is going on too thick.	Move gun faster.
		Choose a tip with smaller hole size.
		Choose tip with wider fan.
		Make sure gun is far enough from surface.
When paint is sprayed, coverage is inadequate.	Coat is going on too thin.	Move gun slower.
		Choose tip with larger hole size.
		Choose tip with narrower fan.
		Make sure gun is close enough to surface.

Problem	Cause	Solution
Fan pattern varies dramatically while spraying. OR Sprayer does not turn on promptly when resuming spraying.	Pressure control switch is worn and causing excessive pressure variation.	Take sprayer to Graco/MAGNUM authorized service center.
Cannot trigger spray gun.	Spray gun trigger lock is locked.	Rotate trigger safety lever to unlock trigger lock, page 13.
Paint is coming out of pressure control switch.	Pressure control switch is worn.	Take sprayer to Graco/MAGNUM authorized service center.
Prime/Spray valve actuates automatically relieving pressure through prime tube.	System is over pressurizing.	Take sprayer to Graco/MAGNUM authorized service center.
Paint leaks down outside of pump.	Pump packings are worn.	A60: Replace pump packings. A20, A30 and A45: Replace pump.
Motor is hot and runs intermittently. Motor automatically shuts off due to excessive heat. Damage can occur if cause is not corrected. See Thermal Overload , page 12.	Vent holes in enclosure are plugged or sprayer is covered.	Keep vent holes clear of obstructions and overspray and keep sprayer open to air.
	Extension cord is too long or not a heavy enough gauge.	Replace extension cord. Read Grounding and Electric Requirements , page 12.
	Unregulated electrical generator being used has excessive voltage.	Use electrical generator with a proper voltage regulator. Sprayer requires 220-240 VAC, 50/60 Hz.

Advanced Troubleshooting



See **Basic Troubleshooting** first, page 15 for problems that are more easily remedied.

Motor Does Not Operate

Specific Problem	Cause	Solution
Basic mechanical problems.	Paint is frozen or hardened in pump.	See Basic Troubleshooting , page 15.
	Gears are damaged.	Remove motor enclosure and rotate motor fan to check for bad gears. If gears bind or slip, remove pump cover and replace failed gears. See List of Kits , page 30.
	A60: Yoke is broken because pump is locked up due to dried paint or worn packings.	Repair or replace using Gear/Yoke Kit . See List of Kits , page 30. Replace pump packings on A60 sprayers. See List of Kits , page 30.

Specific Problem	Cause	Solution
Basic electrical problems.	Motor overheated.	Allow motor to cool for 45 minutes. Retry.
	Electrical outlet is damaged.	Reset building circuit breaker or replace fuse. Try another outlet. Check electric supply with volt meter. Meter must read 220/240 VAC. If voltage is too high, do not plug sprayer in until outlet is corrected.
	Control board leads are improperly fastened, improperly mated, or corroded.	Replace any loose terminals. Make sure all leads and harnesses are firmly connected. A60: Check pressure control harness connection on front side of drive housing. Clean control board terminals. Securely reconnect leads.
	Motor brushes are worn.	Check length of BOTH brushes (brushes do not wear evenly on both sides of the motor). Brush length must be 0.25 in. (6.4mm). If brushes are worn replace motor using Motor Kit . See List of Kits , page 30.
	Motor armature commutator damaged.	Check for burn spots, gouges and extreme roughness. If damaged or if shorts are evident, replace motor using Motor Kit . See List of Kits , page 30.
	Fuse is blown.	Find cause for blown fuse before replacing. Turn the motor fan to check for a locked gear or pump. Use a continuity meter to check for a short to ground caused by a pinched wire. A60: Replace the fuse with correct fuse kit. See List of Kits , page 30. A20, A30, and A45: The fuse is not replaceable. Replace control board. See List of Kits , page 30.
	Motor armature shorting.	Check for shorts. See Motor Diagnostics , page 27. If shorts are evident, use Motor Kit to replace motor. See List of Kits , page 30.
	Motor armature open circuit.	Check motor leads for continuity. If open circuit, check brushes. Use Motor Kit to replace motor. See List of Kits , page 30.
	Control board damaged. CAUTION: Do not perform control board diagnostics until you have determined the armature is good. A damaged armature can burn out a good control board.	See Control Board Diagnostics , page 29. Replace control board if damaged using Control Board Kit . See List of Kits , 30.

Specific Problem	Cause	Solution
Sprayer wiring problems. NOTE: Remove enclosure mounting screws and pull enclosure away from drive housing. Take care not to pull on leads from electrical cord and power switch.	Sprayer power cord damaged.	<ol style="list-style-type: none"> 1. Unplug sprayer power cord. 2. Disconnect brown and blue power cord wires at EMI filter. 3. Plug in power cord. 4. Test voltage between brown and blue wires of power cord. Meter must read 220-240 VAC. 5. Replace power cord if no voltage.
	Sprayer power switch damaged.	<ol style="list-style-type: none"> 1. Unplug sprayer power cord. 2. Disconnect both wires from power switch. 3. Check for continuity between switch terminals. 4. Toggle switch ON and OFF. There should be continuity in the ON position only. 5. Replace power switch if no continuity in ON position.
	A60 diagnosis only: Motor thermal overload cutoff switch damaged. WARNING: See Thermal Overload on page 12.	<ol style="list-style-type: none"> 1. Unplug sprayer power cord. 2. Remove motor harness from control board. 3. Check for continuity between yellow leads or motor harness. 4. If thermal relief switch is open (no continuity) allow motor to cool. 5. If switch remains open after motor cools, replace motor using Motor Kit. See List of Kits, page 30. 6. If thermal relief switch closes after motor cools, find correct cause of overheating.

Circuit Breaker is Tripping

Specific Problem	Cause	Solution
Building circuit breaker opens as soon as sprayer is turned on. NOTE: Remove enclosure mounting screws and pull enclosure away from drive housing. Take care not to pull on leads from electrical cord and power switch.	Sprayer electrical wiring is pinched or insulation is damaged.	Repair or replace any damaged wiring or terminals. Securely reconnect wires.
	Wires between pressure control switch and control board are pinched.	
	Motor armature is shorting.	Check for shorts. See Motor Diagnostics , page 27. If shorts are evident, replace motor using Motor Kit . See List of Kits , page 30.
	Control board is damaged. CAUTION: Do not perform control board diagnostics until you have determined the armature is good. A bad motor armature can burn out a good motor control board.	See Control Board Diagnostics , page 29. Replace control board if damaged using Control Board Kit . See List of Kits , page 30.
Building circuit breaker opens as soon as sprayer is plugged into outlet and sprayer is NOT turned on. NOTE: Remove enclosure mounting screws and pull enclosure away from drive housing. Take care not to pull on leads from electrical cord and power switch.	Sprayer power cord damaged.	<ol style="list-style-type: none"> 1. Unplug sprayer power cord. 2. Disconnect brown and blue power cord wires from EMI filter. 3. Plug in power cord. 4. Test voltage between brown and blue wires of power cord. Meter must read 224-240 VAC. 5. Replace power cord if no voltage.
	Sprayer power switch damaged.	<ol style="list-style-type: none"> 1. Unplug sprayer power cord. 2. Disconnect both wires from power switch. 3. Check for continuity between switch terminals. 4. Toggle switch ON and OFF. There should be continuity in the ON position only. 5. Replace power switch if no continuity in ON position.

Erratic Motor Operation

Specific Problem	Cause	Solution
Sprayer quits after running for 5 to 10 minutes.	Building circuit is overloaded.	Remove other loads from building circuit or find another circuit that has less load. See Grounding and Electrical Requirements , page 12.
	Electrical outlet supplying wrong voltage.	Try another outlet. Check electric supply with volt meter. Meter must read 220-240 VAC. If voltage is too high, do not use outlet until corrected.
	<i>Also see Basic Electrical Problems and Sprayer Wiring Problems, pages 21 - 22.</i>	
	Motor is overheating. Warning: See Thermal Overload , page 12.	After motor cools, operate sprayer and determine if motor stops when trigger on gun is released. If sprayer runs continuously, replace Pressure Control . See List of Kits , page 30. Relieve pressure and remove motor enclosure. Turn motor fan by hand to check for binding gears or seized pump. See List of Kits , page 30.

Low or Fluctuating Output

Specific Problem	Cause	Solution
Pump cycles, but output is low or surging.	See Basic Troubleshooting , page 15.	
	Worn or obstructed inlet and outlet valves.	Check for worn pump valves as follows: Prime sprayer with paint. Turn the Prime/Spray valve to SPRAY position. Turn pressure control fully clockwise. Trigger spray gun briefly. When spray gun trigger is released pump should cycle momentarily and stop. If pump continues to cycle, pump valves may be worn or obstructed. For replacement inlet and outlet valve kits, see List of Kits , page 30.
	Prime/Spray valve is leaking out drain line when Prime/Spray valve is in SPRAY position.	Check Prime/Spray valve for debris trapped on seat and for worn parts. Torque to 130 - 180 in-lb (15.8 - 18.1 N•m). Replace if parts are worn using Prime/Spray Valve Kit . See List of Kits , page 30.
	Voltage from electrical outlet is too low. Low voltages reduce sprayer performance.	Check voltage of outlet. Meter must read 220-240 VAC.
	Extension cord is too long or not heavy enough gauge.	Replace extension cord. See Grounding and Electrical Requirements , page 12.
	Leads from motor or pressure switch to control board are damaged, loose, pinched, or overheated.	Be sure terminals are centered and firmly connected. Inspect for pinched wiring and wiring insulation and terminals for signs of overheating. Replace any loose terminals or damaged wiring. Securely reconnect terminals.
	Motor brushes are worn.	Check length of BOTH brushes (brushes do not wear evenly on both sides of the motor). Brush length must be 0.25 in. (6.4mm). If brushes are worn, replace motor using Motor Kit . See List of Kits , page 30.
	Motor brush springs are broken.	If springs are broken, replace motor using Motor Kit . See List of Kits , page 30.
	Motor brushes are binding in brush holders.	Clean brush holders. Remove carbon dust with small cleaning brush.
	Motor stops before sprayer reaches correct pressure (stall pressure is too low).	Replace pressure control using Pressure Control Switch Kit , page 28.
	Control board is damaged. CAUTION: Do not perform control board diagnostics until you have determined the armature is good. A damaged armature can burn out a good control board.	See Control Board Diagnostics , page 29. If damaged, replace control board using Control Board Kit . See List of Kits , page 30.

Specific Problem	Cause	Solution
Motor runs and pump cycles, but pressure does not build up.	Intake valve or outlet valve is not seating properly.	Remove and clean inlet valves and outlet valves. Replace if necessary. See List of Kits , page 30.
	Pump packings are worn or damaged.	Check for leaking around pump. A60: Replace pump packings. See List of Kits , page 30. A20, A30, A45: Replace complete pump. See List of Kits , page 30.

Excessive Pressure Build Up

Specific Problem	Cause	Solution
Prime/Spray Valve actuates automatically, relieving pressure through drain tube.	Pressure control switch has pinched wires or switch is worn.	Replace pressure control switch using Pressure Control Switch Kit , page 28.
	Water or paint entered pressure control switch or shorted control board.	Use Pressure Control Switch Kit , to replace switch. See List of Kits , page 30.
	Control board failed.	See Control Board Diagnostics , page 29. Replace damaged control board using Control Board Kit . See List of Kits , page 30.

Motor Diagnostics

A20, A30, and A45



Motor Diagnostics reveal a damaged motor or if motor brushes are shorter than 1/4 in. (6.4 mm) replace the motor using **Motor Kit**. See **List of Kits**, page 30.

Setup

1. Unplug power cord and **Relieve Pressure**. See **Pressure Relief Procedure**, page 13.
2. Remove enclosure and disconnect two motor leads. See **Wiring Diagram**, page 53 and 54.
3. Remove motor fan cover by gently prying up on retention tabs on sides of motor. Motor shaft should spin easily when turning fan. If motor shaft does not turn easily, there is a problem with pump, gears, or motor. See **Basic Troubleshooting**, page 15.
4. Inspect motor windings for evidence of overheating. If windings appear burnt and motor smells, replace motor.
5. Use ohmmeter to measure resistance across two motor leads. Resistance of motor should fall within range of 4.0 to 10.0 ohms. If motor falls outside resistance range or is open circuit, replace motor.
6. Use ohmmeter to measure resistance of motor leads to motor laminations. If resistance is not open circuit, replace motor.
7. Inspect length of both brushes by looking at brush torsion spring. If spring is not bottomed out in slot for brush spring, brush length is acceptable. If brushes are worn out, replace motor.

A60



Check for electrical continuity in motor armature, windings and brush as follows:

If Motor Diagnostics reveal a damaged motor or if motor brushes are shorter than 1/4 in. (6.4 mm) or if the motor shaft cannot turn, replace the motor using **Motor Kit**. See **List of Kits**, page 30.

Setup

1. **Relieve Pressure**. See **Pressure Relief Procedure**, page 13.
2. Unplug electric cord.
3. Remove enclosure and disconnect motor leads from control card.
4. Remove fan brace.
5. Remove four screws and front cover.
6. Remove yoke and guide rods.
7. Remove gear.

Armature Short Circuit Spin Test

Quickly turn motor fan by hand. There should not be electrical shorts and fan should coast two or three revolutions before stopping. If fan does not spin freely, armature is shorted. Replace motor using **Motor Kit**. See **List of Kits**, page 30.

Armature, Brushes and Motor Wiring Open Circuit Test (Continuity)

1. Connect a test lead to each of the red and black motor leads.
2. Turn motor fan by hand, about two revolutions per second.
3. If there is an uneven resistance or no resistance measured across the test leads, replace motor using **Motor Kit**. See **List of Kits**, page 30.

Pressure Control Switch Diagnostics

1. Unplug power cord and **Relieve Pressure**. See **Pressure Relief Procedure**, page 13.
2. If paint is leaking from pressure control switch between pressure control knob and base, replace pressure control switch.
3. **A60**: Remove front cover, yoke, and pins. Disconnect pressure control switch connector from control board.

A20, A30, and A45: Remove enclosure and disconnect pressure control switch connector from control board. Use finger to support control board when removing pressure control switch connector.
4. Use ohmmeter to check for no continuity between sprayer ground and both pressure control terminals in connector. If either pressure control switch lead is shorted to ground, pressure control switch wires have been pinched to ground during assembly and pressure control switch needs to be replaced.
5. Use ohmmeter to measure across two terminals in pressure control connector. No continuity should exist when pressure control knob is at lowest pressure setting (full counter-clockwise). Replace pressure control switch if continuity exists.
6. Use ohmmeter to measure across two terminals in pressure control connector. Continuity or closed circuit should exist when pressure control knob is set at maximum pressure (full clockwise). Replace pressure control switch if no continuity exists.

Pump Diagnostics

NOTICE

When repairing or cleaning the pump, never submerge pump in water or allow fluid to enter pressure control.

When pump packings wear, paint begins to leak down the outside of the pump. At the first sign of leakage, replace the pump or additional damage to the drive train could occur.

1. **A20, A30, A45**: Replace pump using **Pump Replacement (Complete)**. See **List of Kits**, page 30.

A60: Replace pump using **Pump Repair Kit**. See **List of Kits**, page 30.
2. If there is no paint leakage (see **Advanced Troubleshooting**, page 20). Pump may not be defective.

Control Board Diagnostics

A60

NOTE: Check for motor problems before replacing control board. A damaged motor may burn out a good control board.

Check for a damaged control board or pressure control switch as follows:



1. **Relieve Pressure** (see **Pressure Relief Procedure**, page 13).
2. Unplug electrical cord.
3. Remove four cover screws and front cover. Remove motor enclosure.
4. Remove yoke and guide rods.
5. Remove gear.
6. Remove pressure control harness from control board. Using tip of small, flat blade screwdriver, press tab on right side connector to release.
7. Attach harness from a pressure control switch you know is functioning correctly to control board.

NOTE: Pressure control switch does not have to be installed in pump.
8. Turn pressure control adjustment knob (C) +to maximum pressure setting.
9. Plug electrical cord into 240 VAC receptacle.
10. Turn power switch (B) ON.
 - If motor runs, replace failed pressure switch. **Pressure Control Switch Kit**. See **List of Kits**, page 30.
 - If motor does not run, replace control board repeat test. **Control Board Kit**. See **List of Kits**, page 30.

A20, A30, and A45

NOTE: Check for motor problems before replacing control board. A damaged motor may burn out a good control board.



1. Unplug electrical cord and **relieve pressure** (see **Pressure Relief Procedure**, page 13).
2. Remove enclosure and check all control board connectors for proper installation (see **Wiring Diagram**, page 53).
3. Check fuse on control board. If fuse is blown, determine the cause before replacing control board (see **Advanced Troubleshooting**, page 20).

List of Kits

Kit Number	Models	Kit Description
16G223	A20, A30, and A45	Control Board Kit
16W944	A60	Control Board Kit
122893	A60	Fuse
16G224	16E664 series A and 16E665 series A	Enclosure Kit
16X022	16E664 series B and 16E665 series B	Enclosure Kit
16X021	17C244 series A and 17C245 series A	Enclosure Kit
16W858	16W108	Enclosure Kit
16W857	17C243	Enclosure Kit
16W996	16W515	Enclosure Kit
288695	17C246	Enclosure Kit
16W859	A20	Front Cover
16W952	A30 and A45	Front Cover
16W945	A60	Front Cover
245449	16W108 and 16E664	Hose, 6.4mm x 7.5m, 6.4mm x 6.4mm fitting
16W433	16E665 and 16W515	Hose 6.4mm x 15m, 6.4mm x 6.4mm fitting
247339	17C243 and 17C244	Hose, cpld 1/4" x 25' w/connector
247350	17C245 and 17C246	Hose, cpld 1/4" x 50' w/connector
257566	A20, A30 and A45	Inlet Strainer
245673	A60	Inlet Strainer
16E839	A30	Stand
16C815	A20	Stand
257569	A45	Left Leg
257568	A45	Right Leg
16W946	A60	Left Leg
16W947	A60	Right Leg
16G226	A30 series A and A45 series A	Power Cord (CEE)
16W951	A20, A30 series B and A45 series B	Power Cord
16W948	A60	Power Cord
289107	A60	AutoPrime
246286	A20, A30, A45 and A60	Pressure Control 3000 psi
16E844	A20, A30 and A45	Pump Inlet
16X380	A60	Pump Inlet
16E845	A20, A30 and A45	Pump Outlet
243094	A60	Pump Outlet
288747	A60	Filter Kit (InstaClean™)
16X519	A20	Pump
16F047	A30 and A45	Pump
288818	A60	Pump
16W431	A30, A45 and A60	SG3 Gun
197607	A20 and A30	Suction Tube
16D951	A45	Suction Tube
15J801	A60	Suction Tube
244035	A20, A30, A45 and A60	Drain Tube Diffuser
235014	A20, A30, A45 and A60	Drain Valve
16G228	A20, A30 and A45	Motor
256938	A60	Motor
16E778	A20, A30 and A45	Gear/Drive
289102	A60	Gear/Drive

Kit Number	Models	Kit Description
16W860	A20	Pump (Complete)
16G227	A30 and A45	Pump (Complete)
16W941	A60	Pump (Complete)
256212	A60	Lacquer Conversion Kit

Parts List

A20 Models 16W108, 17C243

Ref.	Part	Description	Qty.	Ref.	Part	Description	Qty.
1	115489	CLAMP, drain tube	2	42	16W860	KIT, repair, pump, complete (includes 48, 49, 50, and 53)	1
2	116295	CLAMP, tube	1	46	123849	SPRING, compression	1
3	195084	TUBE, drain	1	47	124249	BALL, ceramic, si-n	1
7	112689	SCREW, button HD	4	48	16E844	KIT, repair, inlet valve (includes 46, 47)	1
10	195400	CLIP, spring	2	49	16E845	KIT, repair, outlet valve	1
14	197607	TUBE, suction	1	50	235014	KIT, repair, valve, drain (includes 55)	1
15	244035	DEFLECTOR, barbed	1	51	246286	KIT, repair, pressure control (includes 36, 37)	1
18	16G228	KIT, repair, motor, 230V	1	53	15Y185	KNOB, drain valve	1
19	16C497	COVER, wire	1	55	119956	PIN, straight	1
21	16W859	KIT, repair, front cover (includes 38, 33, 23)	1	66	16E778	KIT, repair, drive (includes 7)	1
23	120724	SCREW	4	68	16W319	COVER, gear housing	1
27	115498	SCREW, mach, slot hex wash HD	1	69	103338	PACKING, o-ring	1
33	16D576	LABEL, made in USA	1	70	16X519	KIT, repair, pump (includes 48, 49)	1
36	15A464	LABEL, control	1	200	195697	STRAINER	1
37	16F635	LABEL, control	1				
38		LABEL, A20, front					
	16W631	Model 16W108	1				
	17C447	Model 17C243	1				

A20 Frame

Models 16W108, 17C243

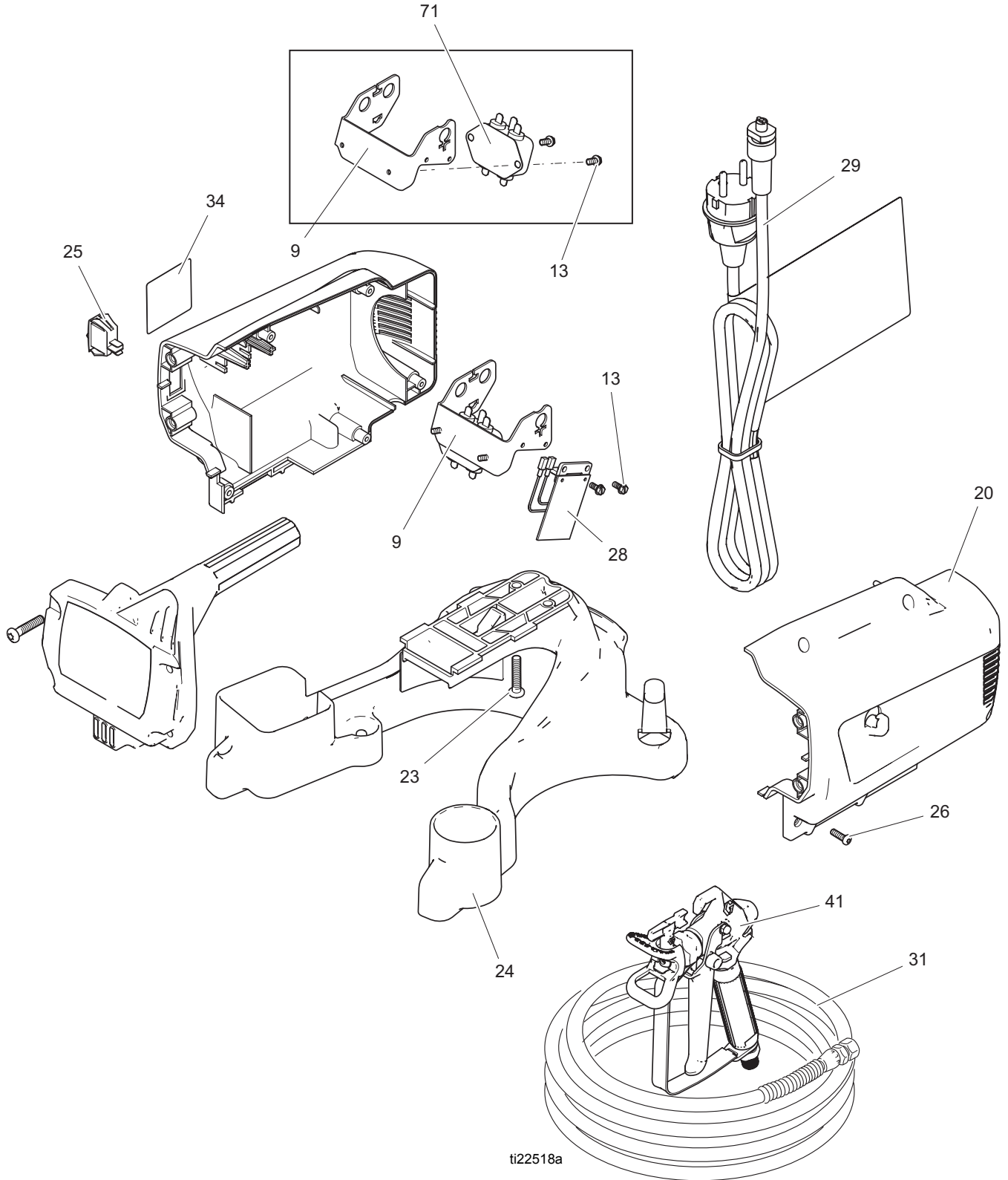

Parts List

A20 Models 16W108, 17C243

Ref.	Part	Description	Qty.	Ref.	Part	Description	Qty.
9	16W317	FILTER, EMI bracket assy (includes 71, 13)	1	31		HOSE, cpld, 1/4 in. x 25 ft.	
13	115492	SCREW, mach, slot hex wash hd	2	245449		Model 16W108	1
20	16W858	KIT, repair, enclosure, A20 (includes 26, 23, 34)	1	247339		Model 17C243	1
23	120724	SCREW	2	34▲	16G596	LABEL, warning	1
24	16W861	KIT, repair, stand (includes 23)	1	41	16W431	KIT, accessory, gun, SG3	1
25	116255	SWITCH,ROCKER,SPST	1	71	16W227	FILTER, EMI	1
26	115477	SCREW, mach,torx pan hd	6	▲	179960	SIGN, warning (not shown)	1
28	16G223	KIT, repair, control board	1	▲		<i>Replacement Danger and Warning labels, tags, and cards are available at no cost.</i>	
29	16W951	KIT, repair, cordset	1				

A30 Pump

Models 16E664 (Series A and B), 17C244 (Series A)

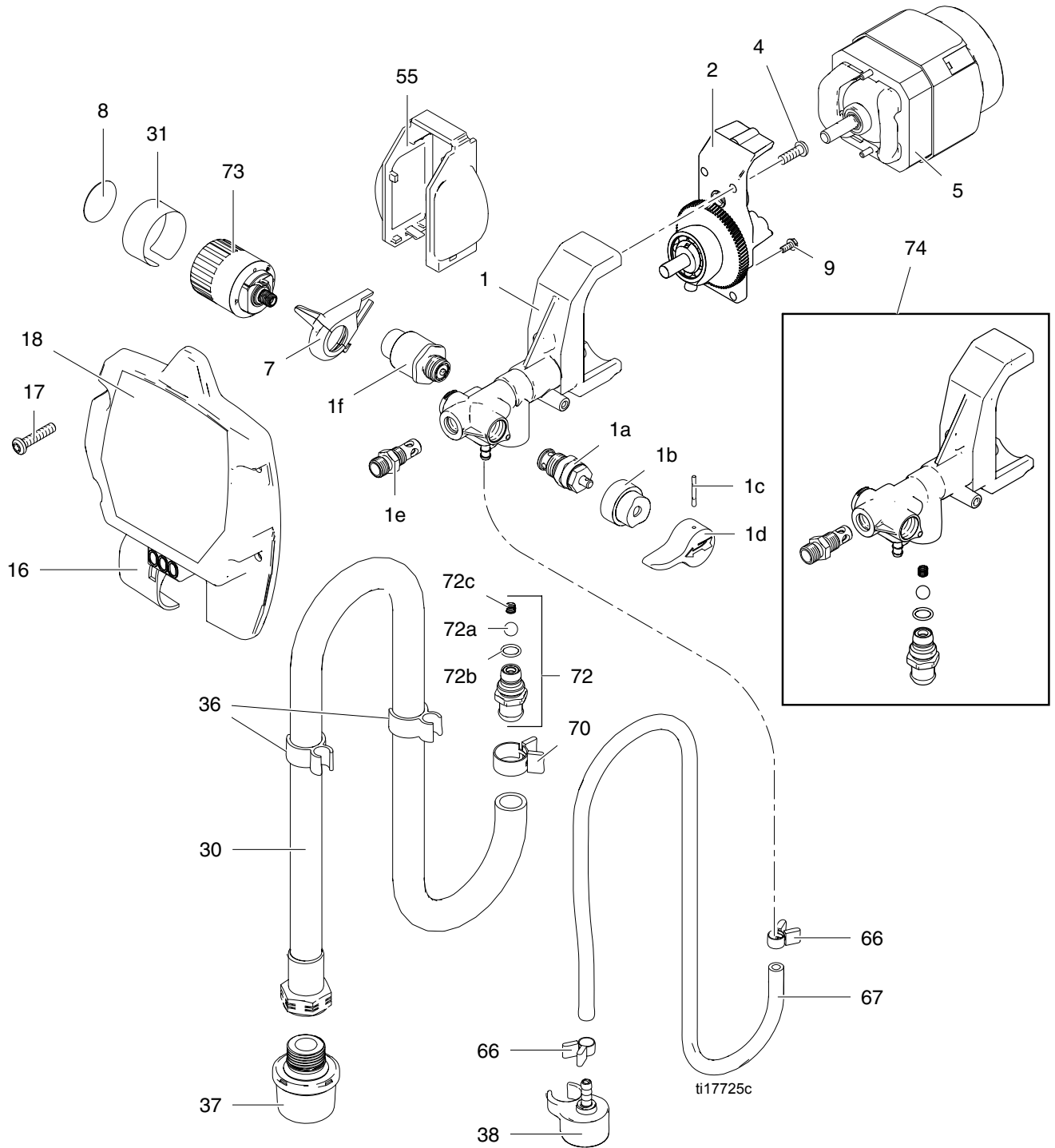

Parts List

A30 Models 16E664 (Series A and B), 17C244 (Series A)

Ref.	Part	Description	Qty.	Ref.	Part	Description	Qty.
1	16G227	KIT, repair, pump, complete (includes 1a, 1b, 1c, 1d, 1e, 1f, 72)	1	30	197607	TUBE, suction set	1
1a	235014	KIT, replacement, valve, drain	1	31	16F635	LABEL, control, Magnum	1
1b	24E578	BASE, valve	1	36	195400	CLIP, spring	2
1c	111600	PIN, grooved	1	37	195697	STRAINER	1
1d	187625	HANDLE, valve, drain	1	38	244035	DEFLECTOR, barbed	1
1e	16E845	KIT, repair, outlet valve	1	55	16W319	COVER, gear	1
1f	16F621	MODULE, AutoPrime	1	66	115489	CLAMP, drain tube	2
2	16E778	KIT, repair, drive (includes 4)	1	67	195084	TUBE, drain	1
4	112689	SCREW, button hd	4	70	116295	CLAMP, tube	1
5	16G228	KIT, repair, motor	1	72	16E844	KIT, repair, inlet valve (includes 72a, 72b, 72c)	1
7	15Y296	COVER, wire	1	72a	124249	BALL	1
8	15A464	LABEL, control	1	72b	103338	PACKING, o-ring	1
9	115498	SCREW, mach, slot hex wash hd	1	72c	123849	SPRING, compression	1
16	16W952	KIT, repair, cover (includes 17, 18)	1	73	246286	KIT, repair, pressure control (includes 8, 31)	1
17	120724	SCREW	4	74	16F047	KIT, repair, pump (includes 1e, 72)	1
18		LABEL, A30, front					
	16F802	Model 16E664	1				
	17C448	Model 17C244	1				

A30 Frame (Series A)

Model 16E664 (Series A)

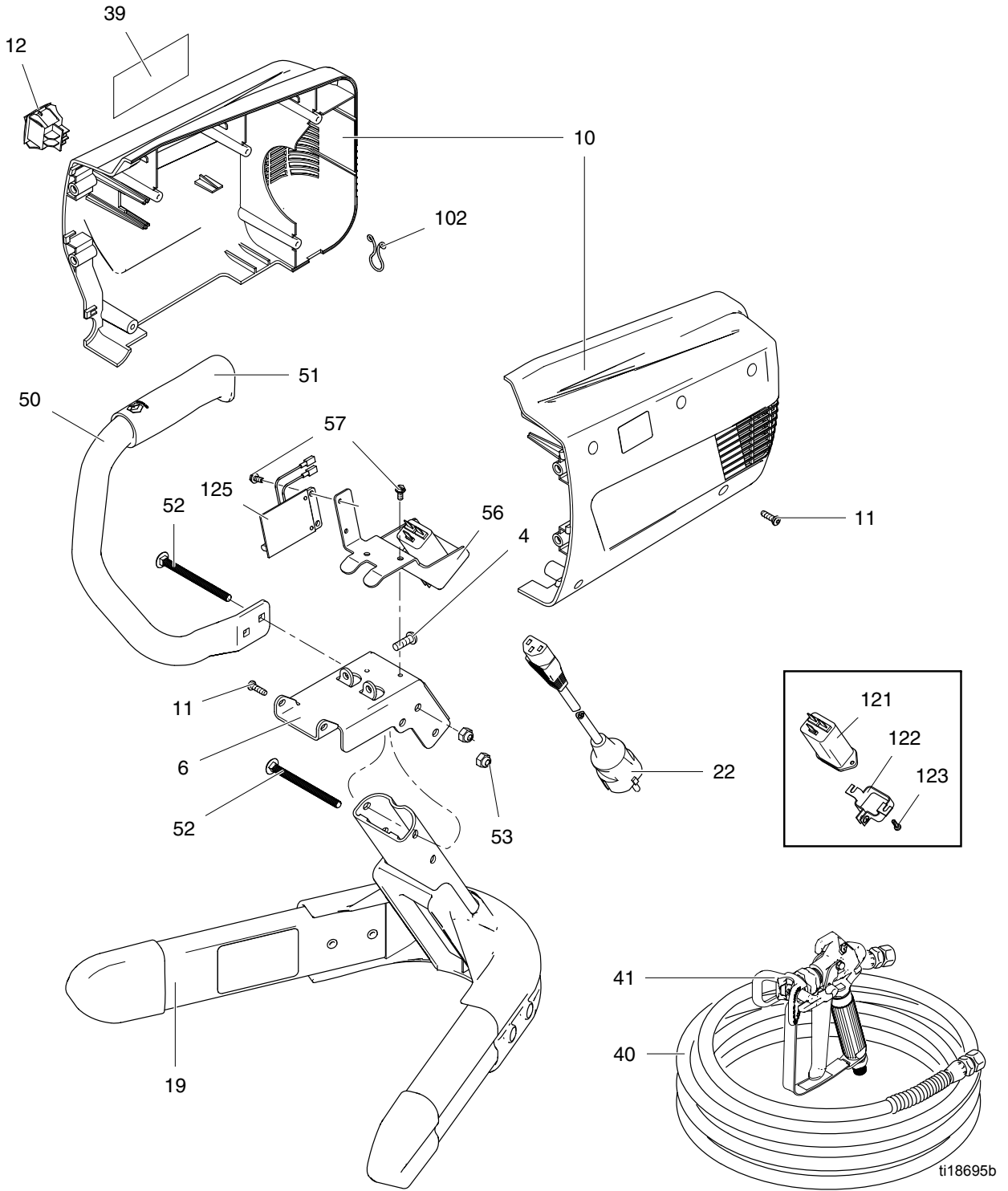

Parts List

A30 Model 16E664 (Series A)

Ref.	Part	Description	Qty.	Ref.	Part	Description	Qty.
4	112689	SCREW	4	50	256992	HANDLE, painted	1
6	16D684	FRAME	1	51	116139	GRIP, handle	1
9	115498	SCREW, mach, slot hex wash hd (not shown)	1	52	122233	BOLT, carriage	3
10	16G224	KIT, repair, enclosure, A30 and A45 series A (includes 11, 17, 39)	1	53	102040	NUT, lock, hex	3
11	115477	SCREW, mach, torx pan hd	6	56	16F567	BRACKET, control board/EMI filter	1
12	118899	SWITCH, rocker, spdt	1	57	115492	SCREW, mach, slot hex wash hd	4
17	120724	SCREW (not shown)	4	102	121423	RETAINER, wire	1
19	16E839	KIT, repair, stand	1	121	245648	FILTER, EMI	1
22	16G226	KIT, repair, cordset	1	122	115632	CLAMP, power cord	1
39▲	16G596	LABEL, warning	1	123	114528	SCREW, mach, phillips, pnhd	2
40	245449	HOSE, cpd, 1/4 in. x 25 ft	1	125	16G223	KIT, repair, control board	1
41	16W431	KIT, accessory, gun, SG3	1				
47▲	179960	SIGN, warning (not shown)	1				

▲ Replacement Danger and Warning labels, tags, and cards are available at no cost.

A30 Frame

Models 16E664 (Series B), 17C244 (Series A)

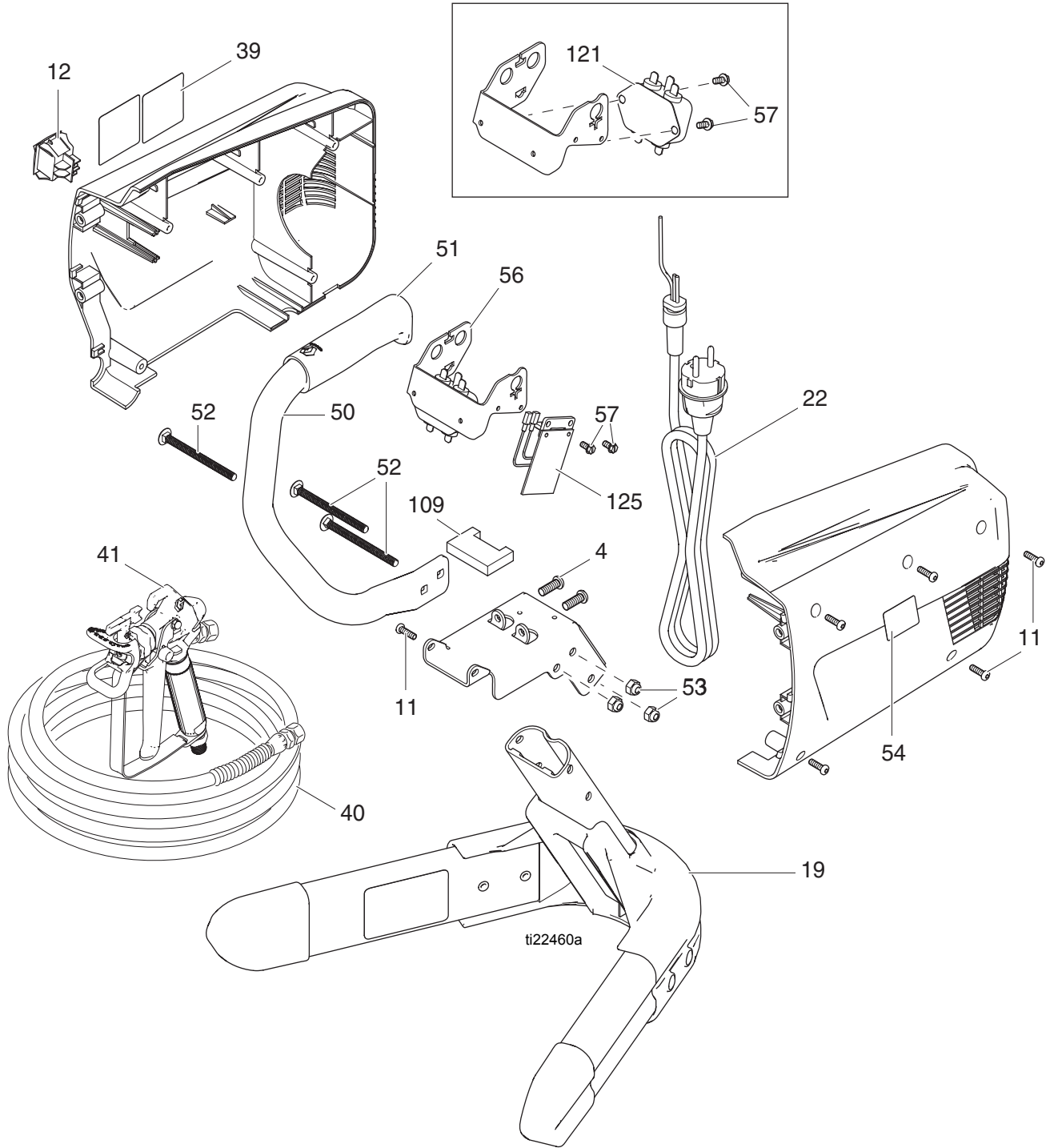

Parts List

A30 Models 16E664 (Series B), 17C244 (Series A)

Ref.	Part	Description	Qty.	Ref.	Part	Description	Qty.
4	112689	SCREW	4	41	16W431	KIT, accessory, gun, SG3	1
6	16D684	FRAME	1	47▲	179960	SIGN, warning (not shown)	1
9	115498	SCREW, mach, slot hex wash hd (not shown)	1	50	256992	HANDLE, painted	1
10	16X022	KIT, repair, enclosure, A30 and A45 series B (includes 11, 17, 39)	1	51	116139	GRIP, handle	1
11	115477	SCREW, mach, torx pan hd	6	52	122233	BOLT, carriage	3
12	118899	SWITCH, rocker, spdt	1	53	102040	NUT, lock, hex	3
17	120724	SCREW (not shown)	4	56	16W317	FILTER, EMI, bracket assembly (includes 57, 121)	1
19	16E839	KIT, repair, stand	1	57	115492	SCREW, mach, slot hex wash hd	4
22	16W951	KIT, repair, cordset	1	102	121423	RETAINER, wire	1
39▲	16G596	LABEL, warning	1	121	16W227	FILTER, EMI	1
40		HOSE, cpld, 1/4 in. x 25 ft	1	125	16G223	KIT, repair, control board	1
	245449	Model 16E664	1	▲	<i>Replacement Danger and Warning labels, tags, and cards are available at no cost.</i>		
	247339	Model 17C244	1				

Parts List

A45 Models 16E665 (Series A and B), 17C245 (Series A)

Ref.	Part	Description	Qty.	Ref.	Part	Description	Qty.
1	16G227	KIT, repair, pump, complete (includes 1a, 1b, 1c, 1d, 1e, 1f, 72)	1	30	16D951	TUBE, suction	1
1a	235014	KIT, replacement, valve, drain	1	31	16F635	LABEL, control, magnum	1
1b	24E578	BASE, valve	1	36	195400	CLIP, spring	1
1c	111600	PIN, grooved	1	37	195697	STRAINER	1
1d	187625	HANDLE, valve, drain	1	38	244035	DEFLECTOR, barbed	1
1e	16E845	KIT, repair, outlet valve	1	63	16W319	COVER, gear	1
1f	16F621	MODULE, AutoPrime	1	66	115489	CLAMP, drain tube	2
2	16E778	KIT, repair, drive (includes 4)	1	67	195108	TUBE, drain	1
4	112689	SCREW, button HD	4	68	16D907	HANGER, pail	1
5	16G228	KIT, repair, motor	1	70	116295	CLAMP, tube	1
7	15Y296	COVER, wire	1	72	16E844	KIT, repair, inlet valve (includes 72a, 72b, 72c)	1
8	15A464	LABEL, control	1	72a	124249	BALL	1
9	115498	SCREW, mach, slot hex wash head	1	72b	103338	PACKING, o-ring	1
16	16W952	KIT, repair, cover (includes 17, 18)	1	72c	123849	SPRING, compression	1
17	120724	SCREW	4	73	246286	KIT, repair, pressure control (includes 8, 31)	1
18		LABEL, A45, front		74	16F047	KIT, repair, pump (includes 1e, 72)	1
	16F803	Model 16E665	1	101	16X731	SCREW, plastite, #8, wash hd	2
	17C449	Model 17C245	1				

A45 Frame

Model 16E665 (Series A)

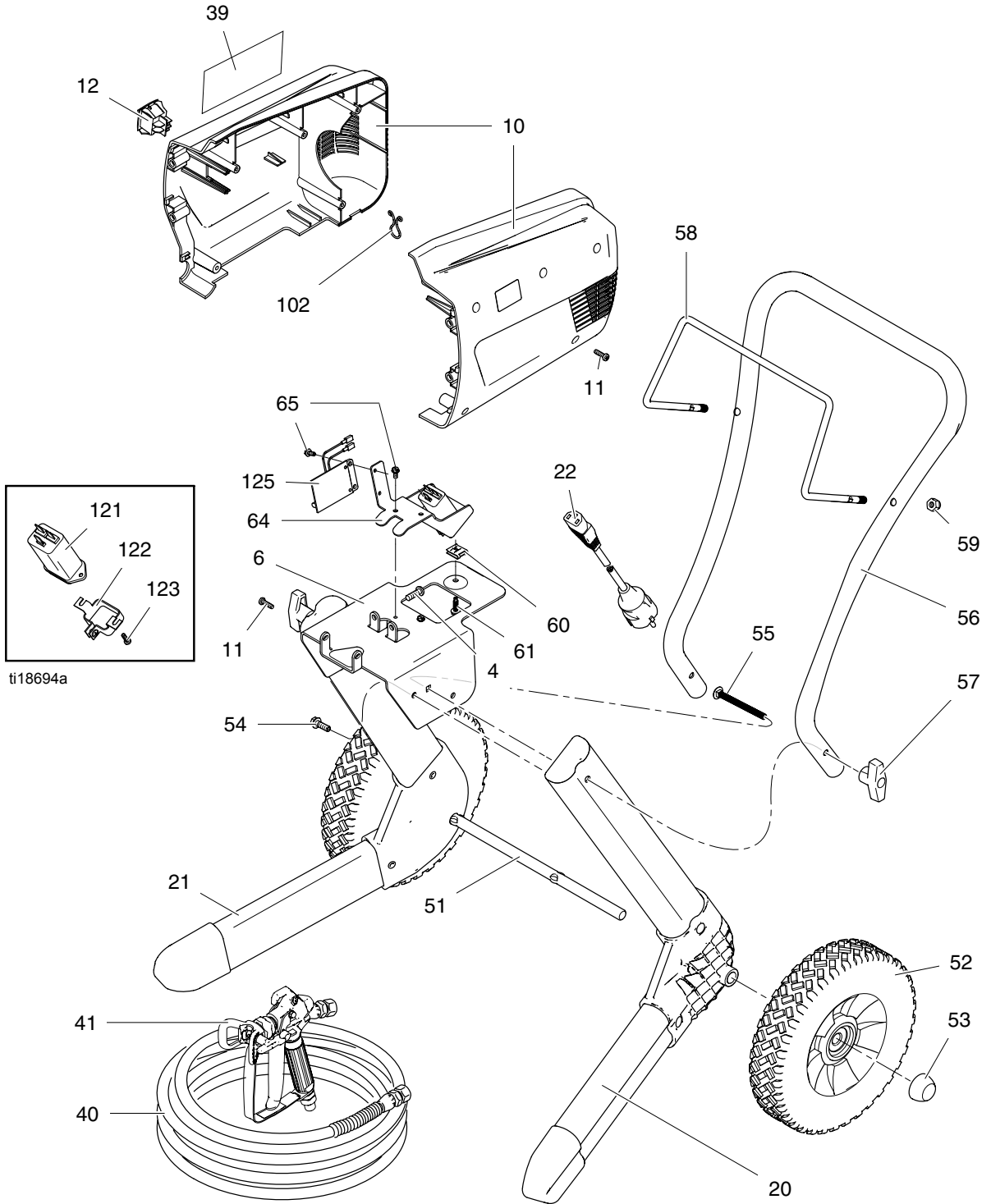

Parts List

A45 Model 16E665 (Series A)

Ref.	Part	Description	Qty.	Ref.	Part	Description	Qty.
4	112689	SCREW, button HD	4	55	120788	SCREW, carriage	2
6	16D685	FRAME	1	56	256993	HANDLE, painted	1
10	16G224	KIT, repair, enclosure, A30 and A45, Series A (includes 11, 17, 39)	1	57	115480	KNOB, t-handle	2
11	115477	SCREW, mach, torx pan hd	6	58	257326	RACK, hose, painted	1
12	118899	SWITCH, rocker, spdt	1	59	120689	NUT, hex, acorn, 5/16-18, nickel	2
17	120724	SCREW (not shown)	4	60	121481	NUT, u-type, tinnerman	1
20	257569	KIT, leg, left (includes 54)	1	61	120093	SCREW, self drilling	1
21	257568	KIT, leg, right (includes 54)	1	64	16F567	BRACKET, control board/EMI filter	1
22	16G226	KIT, repair, cordset	1	65	115492	SCREW, mach, slot hex wash hd	4
39▲	16G596	LABEL, warning	1	102	121423	RETAINER, wire	1
40	16W433	HOSE, cpld, 1/4 in. X 50 ft	1	107	24F530	BOARD, control	1
41	16W431	KIT, accessory, gun, SG3	1	121	245648	FILTER, EMI	1
47▲	179960	SIGN, warning (not shown)	1	122	115632	CLAMP, power cord	1
51	15R602	AXLE, cart	1	123	114528	SCREW, mach, phillips, pnhd	2
52	115095	WHEEL, 9 in.	2	125	16G223	KIT, repair, control board (includes 57)	1
53	112612	CAP, hub	2				
54	260212	SCREW, hex washer hd, thd form	4				

▲ Replacement Danger and Warning labels, tags, and cards are available at no cost.

Parts List

A45 Models 16E665 (Series B), 17C245 (Series A)

Ref.	Part	Description	Qty.	Ref.	Part	Description	Qty.
4	112689	SCREW, button HD	4	53	112612	CAP, hub	2
6	16D685	FRAME	1	54	260212	SCREW, hex washer hd, thd form	4
10	16X022	KIT, repair, enclosure, A30 and A45, Series B (includes 11, 17, 39)	1	55	120788	SCREW, carriage	2
11	115477	SCREW, mach, torx pan hd	6	56	256993	HANDLE, painted	1
12	118899	SWITCH, rocker, spdt	1	57	115480	KNOB, t-handle	2
17	120724	SCREW (not shown)	4	58	257326	RACK, hose, painted	1
20	257569	KIT, leg, left (includes 54)	1	59	120689	NUT, hex, acorn, 5/16-18, nickel	2
21	257568	KIT, leg, right (includes 54)	1	60	121481	NUT, u-type, tinnerman	1
22	16W951	KIT, repair, cordset	1	61	120093	SCREW, self drilling	1
39▲	16G596	LABEL, warning	1	64	16W317	FILTER, EMI bracket assembly (includes 101, 121)	1
40		HOSE, cpld, 1/4 in. X 50 ft	1	65	115492	SCREW, mach, slot hex wash hd	4
	16W433	Model 16E665		102	121423	RETAINER, wire	1
	247340	Model 17C245		121	16W227	FILTER, EMI	1
41	16W431	KIT, accessory, gun, SG3	1	125	16G223	KIT, repair, control board (includes 57)	1
47▲	179960	SIGN, warning (not shown)	1				
51	15R602	AXLE, cart	1				
52	115095	WHEEL, 9 in.	2	▲	<i>Replacement Danger and Warning labels, tags, and cards are available at no cost.</i>		

A60 Pump

Models 16W515, 17C246

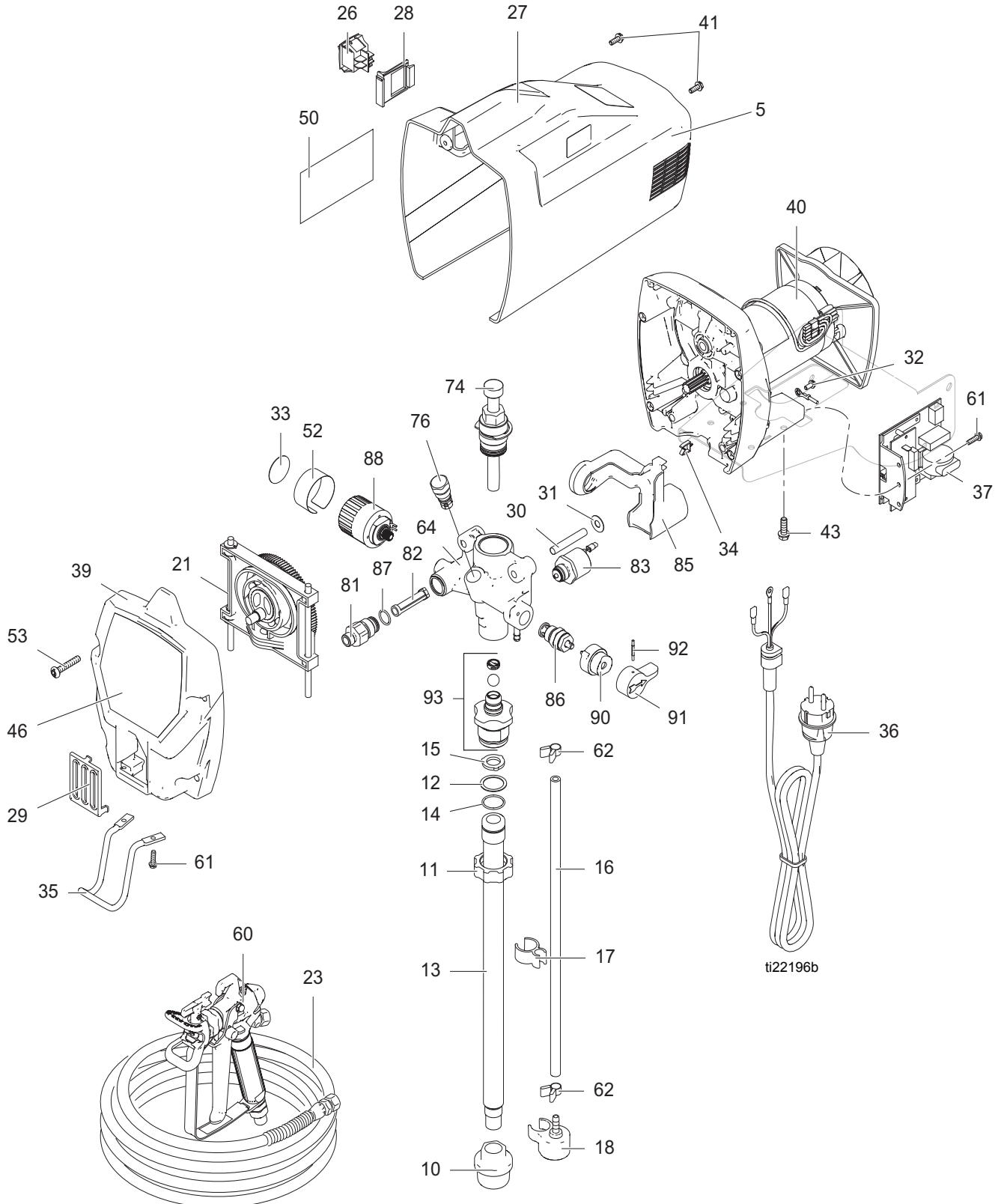

Parts List

A60 Models 16W515, 17C246

Ref.	Part	Description	Qty.	Ref.	Part	Description	Qty.
5	16D576	LABEL,made in USA	1	41	118444	SCREW, mach, slot hex wash hd	2
10	245673	STRAINER, 3/4-16 unf	1	43	260212	SCREW, hex washer hd, thd form	4
11	15E813	NUT, jam	1	46		LABEL, A60, front	
12	15B652	WASHER, suction	1		16W632	Model 16W515	1
13	15J801	TUBE, suction, intake	1		17C450	Model 17C246	1
14	103413	PACKING, o-ring	1	50▲	16G596	LABEL, warning	1
15	115099	WASHER, garden hose	1	52	16F635	LABEL, control	1
16	195108	TUBE, drain	1	53	115478	SCREW, mach, torx/slt pan hd	4
17	195400	CLIP, spring	1	60	16W431	KIT, accessory, gun, SG3	1
18	244035	DEFLECTOR, barbed	1	61	121939	SCREW, plastite, #8 hex wash hd	3
21	289102	KIT, repair, gear and yoke	2	62	115489	CLAMP, drain tube	2
23		HOSE, cpld,1/4 in. x 50 ft		64	16W941	KIT, repair, pump, complete (includes 74, 76, 81, 82, 86, 87, 90, 91, 93)	1
	16W433	Model 16W515	1				
	247340	Model 17C246	1	74	288818	KIT, repair, pump	1
26	118899	SWITCH, rocker, spdt	1	76	243094	KIT, repair, outlet, valve	1
27	16W996	KIT, repair, enclosure, A60 (includes 5, 41, 50)	1	81	195947	ADAPTER, filter	1
28		BRACKET, switch		82	288747	KIT, filter, pump	1
	15X737	Model 16W515	1	83	289107	KIT, repair, autoprime	1
	15J803	Model 17C246	1	85	15J802	COVER, solenoid	1
29	15J809	COVER, pump outlet	1	86	235014	KIT, replacement, valve, drain	1
30	194507	PIN, dowel, 5/16	2	87	115719	PACKING, o-ring, 015	1
31	196001	WASHER	2	88	246286	KIT, repair, pressure control (includes 33, 52)	1
32	115498	SCREW, mach, slot hex wash hd	1	90	224807	BASE, valve	1
33	15A464	LABEL, control	1	91	187625	HANDLE, valve, drain	1
34	119275	CLIP, wire	1	92	111600	PIN, grooved	1
35	15J790	HOOK, pail	1	93	16X380	KIT, repair, inlet, valve	1
36	16W948	KIT, repair, cordset (includes 32)	1	▲	179960	SIGN, warning (not shown)	
37	16W944	KIT, repair, control (includes 61)	1				
39	16W945	KIT, repair, cover (includes 29, 30, 31, 46, 53)	1	▲			
40	256938	KIT, repair, motor	1				

▲ Replacement Danger and Warning labels, tags, and cards are available at no cost.

A60 Frame

Models 16W515, 17C246

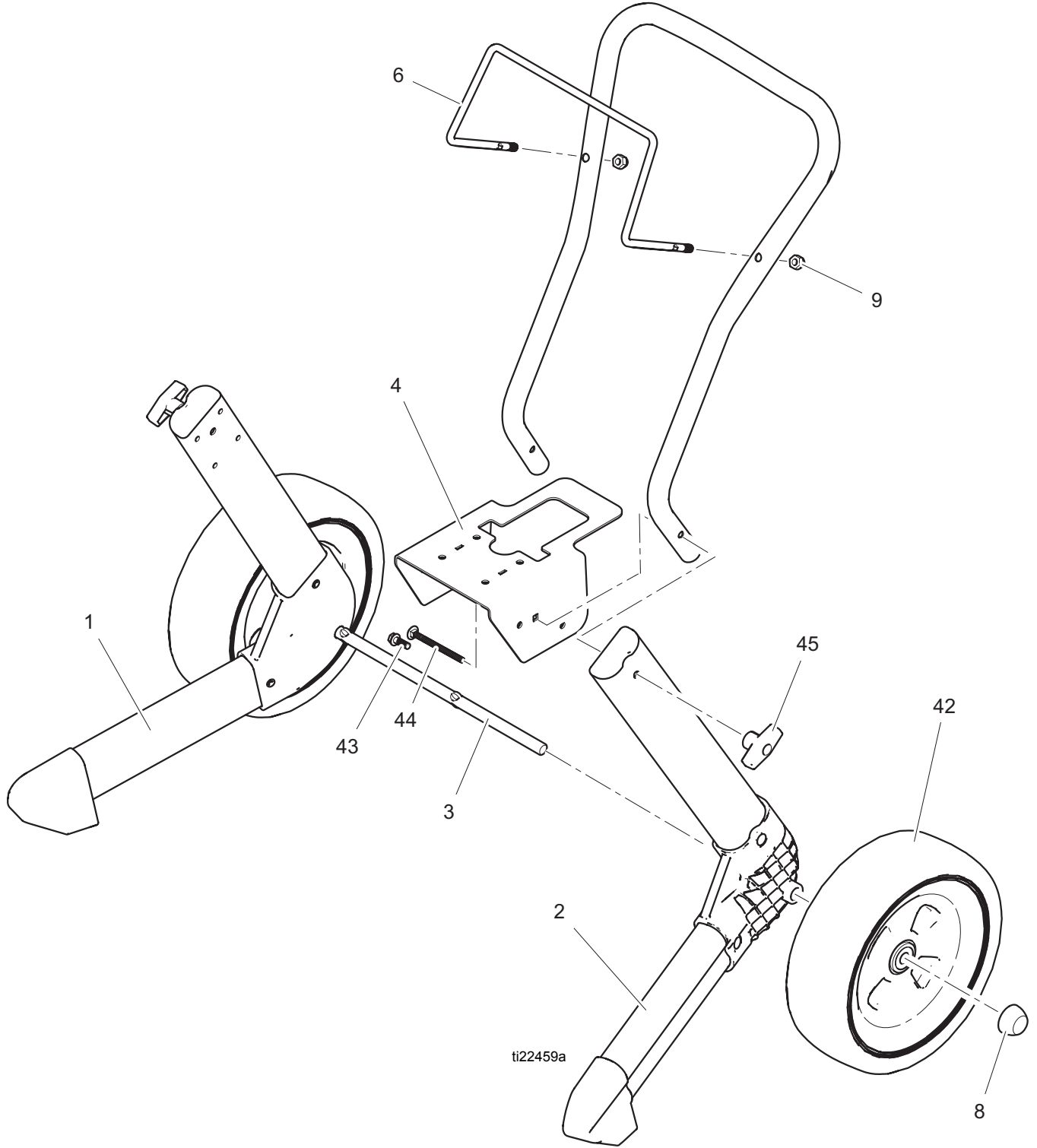

Parts List

A60 Models 16W515, 17C246

Ref.	Part	Description	Qty.	Ref.	Part	Description	Qty.
1	16W947	KIT, repair, right leg (includes 43)	1	8	112612	CAP, hub	2
2	16W946	KIT, repair, left leg (includes 43)	1	9	120689	NUT, hex, acorn, 5/16-18, nickel	2
3	16W362	AXLE, cart	1	42	115094	WHEEL, 10 in.	2
4	16W200	SHELF, motor	1	43	260212	SCREW, hex washer, hd, thd form	4
6	257326	RACK, hose	1	44	120788	SCREW, carriage	2
7	256993	HANDLE, painted	1	45	115480	KNOB, t-handle	2

Wiring Diagram

A30 (Series A) and A45 (Series A)

Models 16E664 (Series A) and 16E665 (Series A)

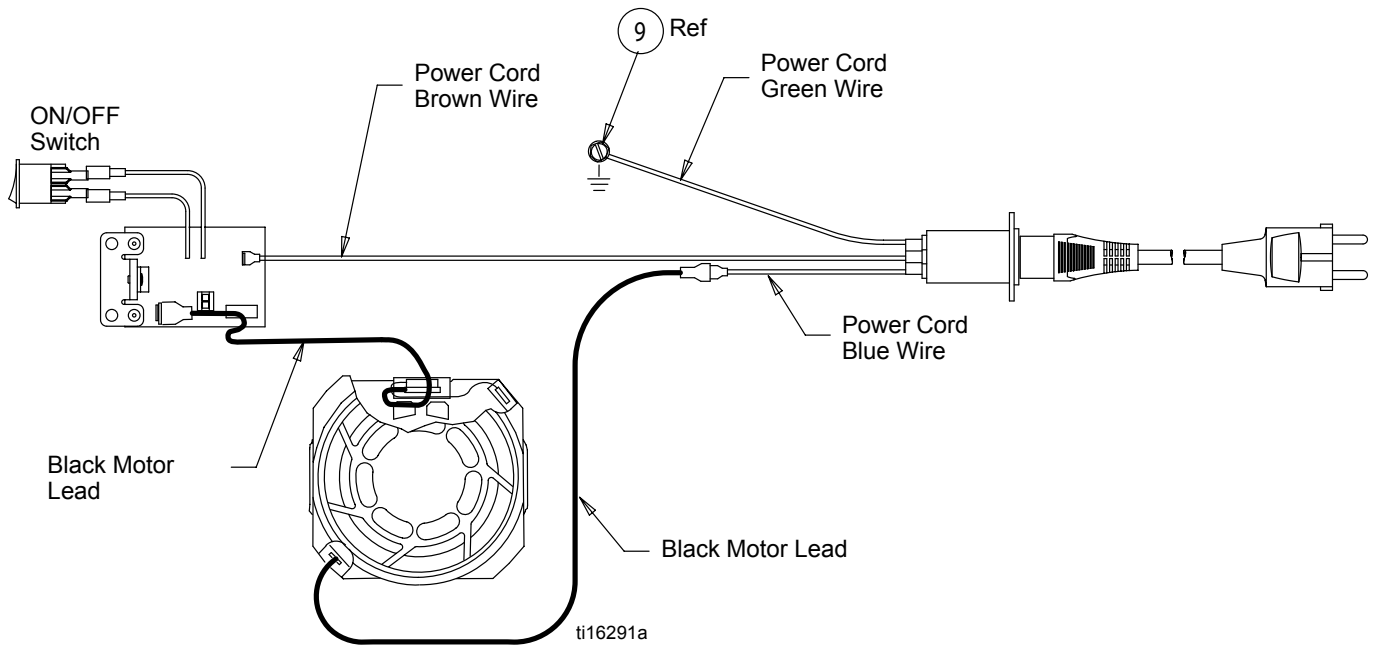

A20, A30 and A45

Models 16W108 (Series A), 16E664 (Series B), 16E665 (Series B)
Models 17C243 (Series A), 17C244 (Series A)

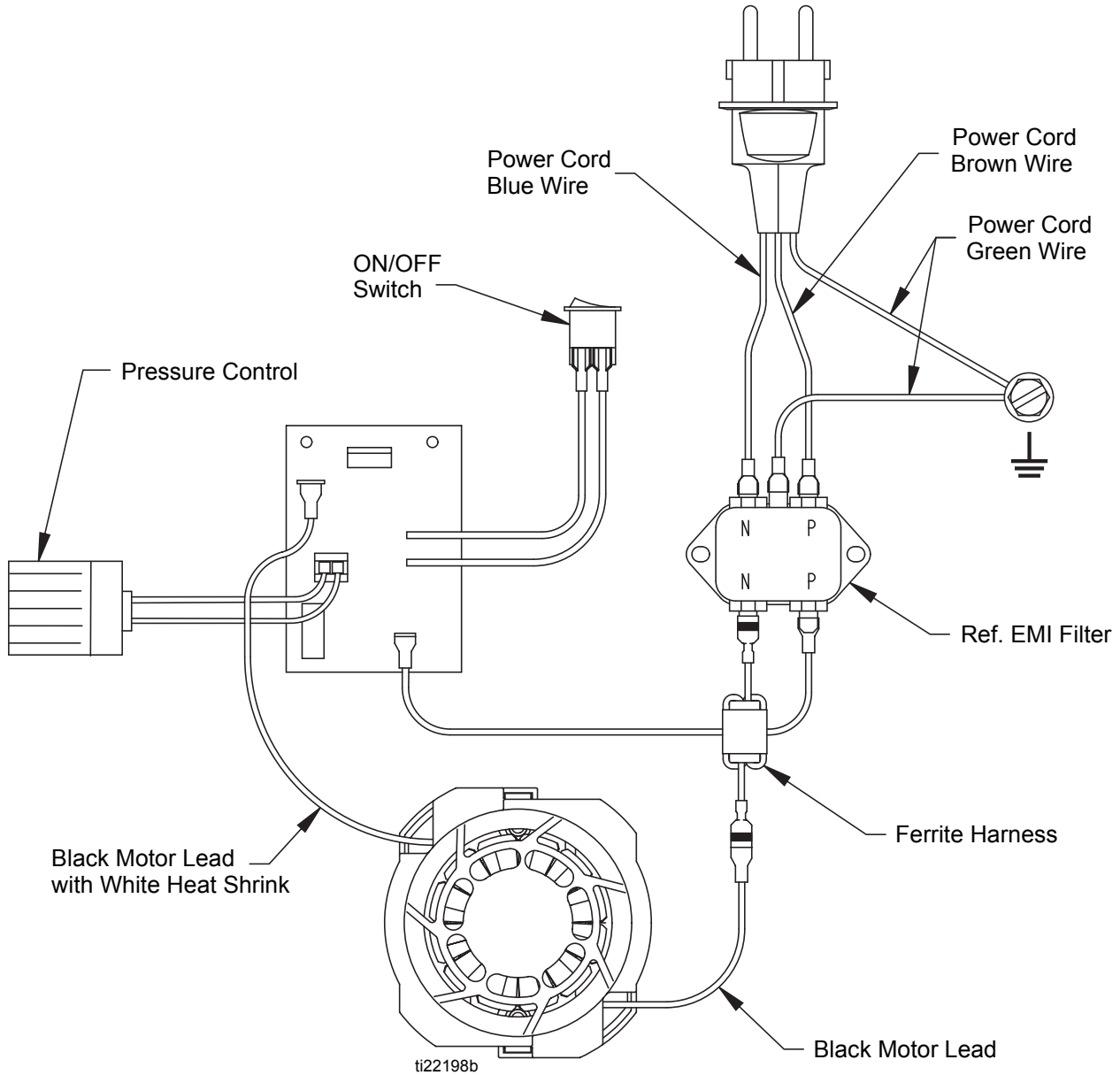

A60

Models 16W515, 17C246

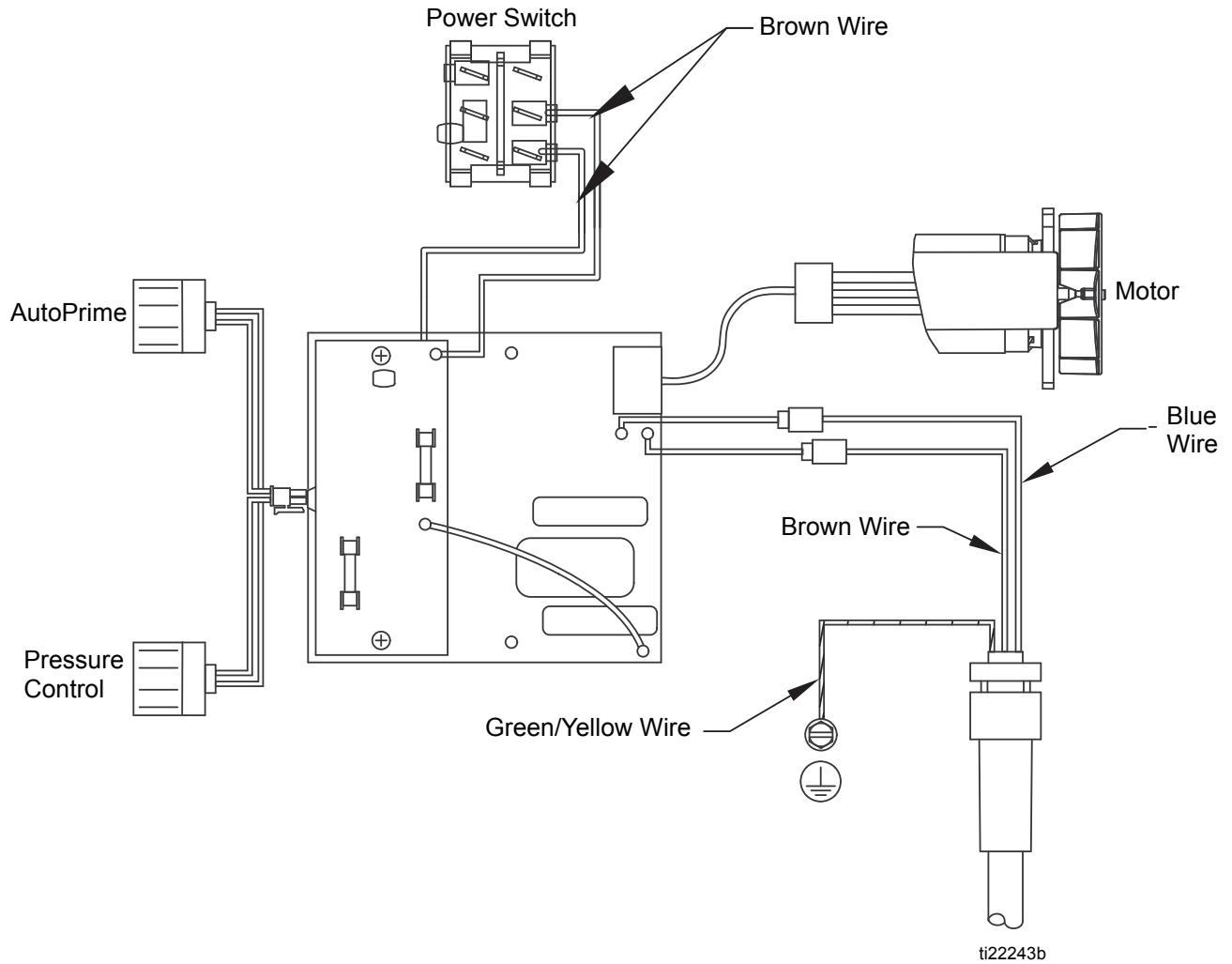

Technical Data

	A20	A30
Working pressure range	0-207 BAR, 0-21 Mpa (0-3000 psi)	
Electric Motor	4.5A (open frame, universal)	
Operating horsepower	3/8	1/2
Maximum delivery (with tip)	.91 lpm (.24 gpm)	1.02 lpm (.27 gpm)
Paint hose	6.4mm X 7.5 m (1/4 in. x 25 ft)	
Maximum tip hole size	0.015 in. (0.38 mm)	
Weight, Sprayer only	4.5 kg (10.0 lb)	5.4 kg (12 lb)
Weight, sprayer, hose, & gun	6.0 kg (13.3 lb)	6.9 kg (15.2 lb)
Dimensions (Upright):		
Length	35.2 cm (13.8 in)	36.8 cm (14.5 in)
Width	30.7 cm (12.1 in)	31.5 cm (12.4 in)
Height	35.1 cm (13.8 in)	45.5 cm (17.9 in)
Dimensions (Folded):		
Length	N/A	
Width	N/A	
Height	N/A	
Power cord	1.0 mm ² , 3-wire, 1.8 m (6 ft.)	
Fluid inlet fitting	1/4 npsm external thread	
Fluid outlet fitting	3/4 in. internally threaded (standard garden hose)	
Inlet screen (on suction tube)	1190 micron (16 mesh)	
Wetted parts, pump and hose	stainless steel, zinc plated carbon steel, brass, ultra-high molecular weight polyethylene (UHMWPE), Carbide, Nylon, Aluminum, PVC, polypropylene, fluoroelastomer	
Wetted parts, gun	aluminum, brass, carbide, nylon, ultra-high molecular weight polyethylene (UHMWPE), zinc	
Generator requirement	1500 Watt minimum	
Electrical power requirement	220-240V AC 50/60 Hz, 1 phase, 10A	
Storage temperature range◆❖	-35° to 71° C (-30° to 160° F)	
Operating temperature range✓	4° to 46° C (40° to 115° F)	

- ◆ When pump is stored with non-freezing fluid. Pump damage will occur if water or latex paint freezes in pump.
- ❖ Damage to plastic parts may result if impact occurs in low temperature conditions.
- ✓ Changes in paint viscosity at very low or very high temperatures can affect sprayer performance.

	A45	A60
Working pressure range	0-207 BAR, 0-21 Mpa (0-3000 psi)	
Electric Motor	4.5A (open frame, universal)	6.5A (open frame, permanent magnet DC)
Operating horsepower	5/8	7/8
Maximum delivery (with tip)	1.17 lpm (.31 gpm)	1.44 lpm (.38 gpm)
Paint hose	6.4mm X 15 m (1/4 in. x 50 ft)	
Maximum tip hole size	0.017 in. (0.43 mm)	0.019 in. (0.48 mm)
Weight, sprayer only	10.6 kg (23.3 lb)	15 kg (33.0 lb)
Weight, sprayer, hose, & gun	12.7 kg (26.5 lb)	17.1 kg (37.7 lb)
Dimensions (Upright):		
Length	49.0 cm (19.3 in)	54 cm (21.3 in)
Width	38.9 cm (15.3 in)	43.8 cm (17.3 in)
Height	94.0 cm (37.0 in)	94.5 cm (37.2 in)
Dimensions (Folded):		
Length	49.0 cm (19.3 in)	54 cm (21.3 in)
Width	38.9 cm (15.3 in)	43.8 cm (17.3 in)
Height	74.2 cm (29.2 in)	74.7 cm (29.4 in)
Power cord	1.0 mm ² , 3-wire, 1.8 m (6 ft)	
Fluid inlet fitting	1/4 npsm external thread	
Fluid outlet fitting	3/4 in. internally threaded (standard garden hose)	7/8 - 14 UNF external thread
Inlet screen (on suction tube)	1190 micron (16 mesh)	1680 micron (12 mesh)
Wetted parts, pump and hose	stainless steel, zinc plated carbon steel, brass, ultra-high molecular weight polyethylene (UHMWPE), Carbide, Nylon, Aluminum, PVC, polypropylene, fluoroelastomer	stainless steel, zinc plated carbon steel, brass, leather, ultra-high molecular weight polyethylene (UHMWPE), Carbide, Nylon, Aluminum, PVC, polypropylene, fluoroelastomer
Wetted parts, gun	aluminum, brass, carbide, nylon, ultra-high molecular weight polyethylene (UHMWPE), zinc	
Generator requirement	1500 Watt minimum	
Electrical power requirement	220-240V AC 50/60 Hz, 1 phase, 10A	
Storage temperature range◆❖	-35° to 71° C (-30° to 160° F)	
Operating temperature range✓	4° to 46° C (40° to 115° F)	

- ◆ When pump is stored with non-freezing fluid. Pump damage will occur if water or latex paint freezes in pump.
- ❖ Damage to plastic parts may result if impact occurs in low temperature conditions.
- ✓ Changes in paint viscosity at very low or very high temperatures can affect sprayer performance.

Graco Standard Warranty

Graco warrants all equipment referenced in this document which is manufactured by Graco and bearing its name to be free from defects in material and workmanship on the date of sale to the original purchaser for use. With the exception of any special, extended, or limited warranty published by Graco, Graco will, for a period of twelve months from the date of sale, repair or replace any part of the equipment determined by Graco to be defective. This warranty applies only when the equipment is installed, operated and maintained in accordance with Graco's written recommendations.

This warranty does not cover, and Graco shall not be liable for general wear and tear, or any malfunction, damage or wear caused by faulty installation, misapplication, abrasion, corrosion, inadequate or improper maintenance, negligence, accident, tampering, or substitution of non-Graco component parts. Nor shall Graco be liable for malfunction, damage or wear caused by the incompatibility of Graco equipment with structures, accessories, equipment or materials not supplied by Graco, or the improper design, manufacture, installation, operation or maintenance of structures, accessories, equipment or materials not supplied by Graco.

This warranty is conditioned upon the prepaid return of the equipment claimed to be defective to an authorized Graco distributor for verification of the claimed defect. If the claimed defect is verified, Graco will repair or replace free of charge any defective parts. The equipment will be returned to the original purchaser transportation prepaid. If inspection of the equipment does not disclose any defect in material or workmanship, repairs will be made at a reasonable charge, which charges may include the costs of parts, labor, and transportation.

THIS WARRANTY IS EXCLUSIVE, AND IS IN LIEU OF ANY OTHER WARRANTIES, EXPRESS OR IMPLIED, INCLUDING BUT NOT LIMITED TO WARRANTY OF MERCHANTABILITY OR WARRANTY OF FITNESS FOR A PARTICULAR PURPOSE.

Graco's sole obligation and buyer's sole remedy for any breach of warranty shall be as set forth above. The buyer agrees that no other remedy (including, but not limited to, incidental or consequential damages for lost profits, lost sales, injury to person or property, or any other incidental or consequential loss) shall be available. Any action for breach of warranty must be brought within two (2) years of the date of sale.

GRACO MAKES NO WARRANTY, AND DISCLAIMS ALL IMPLIED WARRANTIES OF MERCHANTABILITY AND FITNESS FOR A PARTICULAR PURPOSE, IN CONNECTION WITH ACCESSORIES, EQUIPMENT, MATERIALS OR COMPONENTS SOLD BUT NOT MANUFACTURED BY GRACO. These items sold, but not manufactured by Graco (such as electric motors, switches, hose, etc.), are subject to the warranty, if any, of their manufacturer. Graco will provide purchaser with reasonable assistance in making any claim for breach of these warranties.

In no event will Graco be liable for indirect, incidental, special or consequential damages resulting from Graco supplying equipment hereunder, or the furnishing, performance, or use of any products or other goods sold hereto, whether due to a breach of contract, breach of warranty, the negligence of Graco, or otherwise.

FOR GRACO CANADA CUSTOMERS

The Parties acknowledge that they have required that the present document, as well as all documents, notices and legal proceedings entered into, given or instituted pursuant hereto or relating directly or indirectly hereto, be drawn up in English.

Les parties reconnaissent avoir convenu que la rédaction du présente document sera en Anglais, ainsi que tous documents, avis et procédures judiciaires exécutés, donnés ou intentés, à la suite de ou en rapport, directement ou indirectement, avec les procédures concernées.

Graco Information

For the latest information about Graco products, visit www.graco.com.

For patent information, see www.graco.com/patents.

*All written and visual data contained in this document reflects the latest product information available at the time of publication.
Graco reserves the right to make changes at any time without notice.*

Original instructions. This manual contains English. MM 332697

Graco Headquarters: Minneapolis

International Offices: Belgium, China, Japan, Korea

GRACO INC. AND SUBSIDIARIES • P.O. BOX 1441 • MINNEAPOLIS MN 55440-1441 • USA

Copyright 2013 Graco Inc. All Graco manufacturing locations are registered to ISO 9001.

www.graco.com

Revision August 2014