

Horizontal Hydraulic Driver

3A0020B

ENG

For use with two horizontally mounted proportioning pumps. For professional use only.

Not for use in explosive atmospheres.

258771 - Horizontal Hydraulic Driver

1200 psi (8.2 MPa, 82.7 bar) Maximum Working Pressure



Important Safety Instructions

Read all warnings and instructions in this manual and all supplied manuals. Save all instructions.

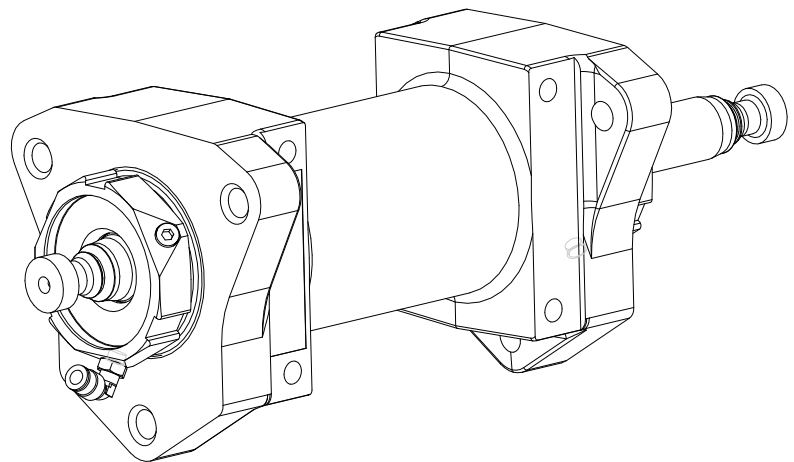





r_258640_3A0020A_1h

Contents

Warnings	2	Dimensions	8
Repair	3	Mounting Hole Layout	8
Disassembly	3	Technical Data	9
Assembly	4	Graco Standard Warranty	10
Parts	6	Graco Information	10

Warnings

The following warnings are for the setup, use, grounding, maintenance, and repair of this equipment. The exclamation point symbol alerts you to a general warning and the hazard symbol refers to procedure-specific risk. Refer back to these warnings. Additional, product-specific warnings may be found throughout the body of this manual where applicable.

 WARNING	
	<p>EQUIPMENT MISUSE HAZARD</p> <p>Misuse can cause death or serious injury.</p> <ul style="list-style-type: none"> • Do not operate the unit when fatigued or under the influence of drugs or alcohol. • Do not exceed the maximum working pressure or temperature rating of the lowest rated system component. See Technical Data in all equipment manuals. • Do not leave the work area while equipment is energized or under pressure. Turn off all equipment and follow the Pressure Relief Procedure when equipment is not in use. • Check equipment daily. Repair or replace worn or damaged parts immediately with genuine manufacturer's replacement parts only. • Do not alter or modify equipment. • Use equipment only for its intended purpose. Call your distributor for information. • Route hoses and cables away from traffic areas, sharp edges, moving parts, and hot surfaces. • Do not kink or over bend hoses or use hoses to pull equipment. • Keep children and animals away from work area. • Comply with all applicable safety regulations.
	<p>BURN HAZARD</p> <p>Equipment surfaces and fluid that's heated can become very hot during operation. To avoid severe burns:</p> <ul style="list-style-type: none"> • Do not touch hot fluid or equipment. • Wait until equipment/fluid has cooled completely.
	<p>PERSONAL PROTECTIVE EQUIPMENT</p> <p>You must wear appropriate protective equipment when operating, servicing, or when in the operating area of the equipment to help protect you from serious injury, including eye injury, inhalation of toxic fumes, burns, and hearing loss. This equipment includes but is not limited to:</p> <ul style="list-style-type: none"> • Protective eyewear • Clothing and respirator as recommended by the fluid and solvent manufacturer • Gloves • Hearing protection

Repair

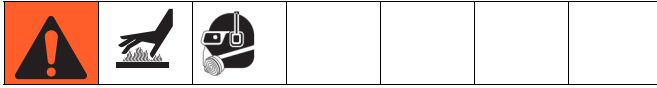

NOTICE

Recommended Hydraulic Oil

Use Graco-approved Hydraulic Oil, Part No. 169236 (5 gal) or 207428 (1 gal)) or a premium, ISO grade 46 petroleum-based hydraulic oil containing rust and oxidation inhibitors and anti-wear agents.

Before using any other type of oil in this motor, contact your Graco distributor. Unauthorized use of lesser grade oil or substitutes may void the warranty.

Hydraulic Oil Working Temperature

The maximum hydraulic oil operating temperature is 160 °F (71 °C). The motor seals will wear faster and leakage may occur if the pump is operated at higher oil temperatures.

If the hydraulic oil temperature approaches 160 °F (71 °C), check the hydraulic fluid supply cooling system, filters, etc. and clean or repair as needed.

Keep the hydraulic system clean

To reduce the risk of damaging the hydraulic driver, verify that the hydraulic power supply fluid lines and reservoir are clean and free from contaminants.

Carefully follow the manufacturer's recommendations on reservoir and filter cleaning, flushing, and periodic changes of hydraulic fluid.

Always plug the hydraulic inlets, outlets and lines when disconnecting them to avoid introducing dirt and other contaminants into the system.

Required Tools

- Vise with soft jaws
- Set of adjustable wrenches
- O-ring pick
- 3/16 in. hex key
- Rubber mallet
- 3 1/4 in. socket
- Torque wrench capable of 150 ft-lbs (203 N•m).
- Anti-seize lubricant
- Pipe sealant

Disassembly

1. Relieve pressure. See system manual for pressure relief instructions.
2. Use two people to lift and clamp the cylinder (1) in a vise.

NOTICE

To prevent damage to sealing surfaces, do not clamp any sealing surfaces in the vise.

3. Remove elbow fittings (4) from outside of seal housings (2).



NOTICE

To prevent damage to the driver, avoid getting dust or dirt in the driver during service.

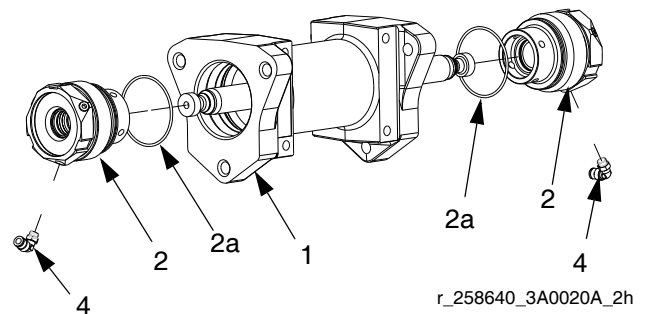
4. Use a 3 1/4 in. socket or wrench to remove one seal housing (2). Place a waste container below the seal housing and cylinder (1) to drain any residual hydraulic oil.



5. Remove second seal housing (2).
6. Remove o-rings (2a) from seal housings (2).

						
Residual hydraulic oil in the cylinder can spray out of ports during removal of the piston assembly.						

NOTE: Be careful not to damage piston rod assembly (9).

- Place a cloth over the hydraulic ports (P). Use a rubber mallet to tap piston rod assembly (9) out of cylinder (1).

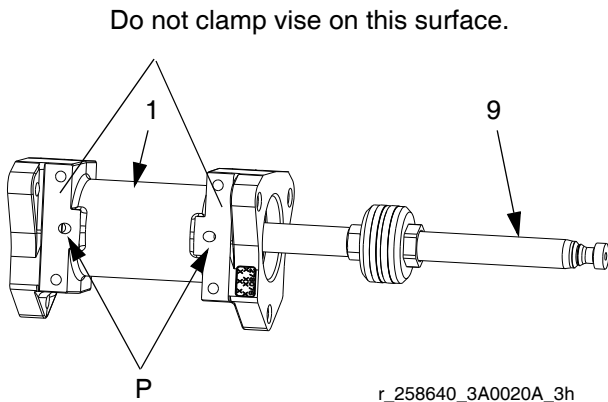

NOTICE
To avoid damaging piston rod, do not clamp on piston rod surface.

- Clamp piston rod flats (9) in a vise to prevent damage to piston rod.
- Use o-ring pick to remove sealing ring and rubber energizing ring of bidirectional seal (9b). Remove bearing (9c).

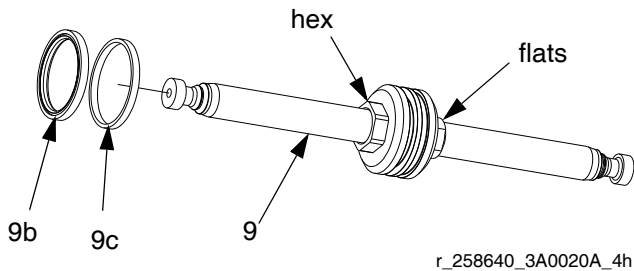

- Thoroughly clean all metal parts in a compatible solvent and inspect for wear or damage. Replace as necessary.

Assembly

NOTE: Be careful not to damage piston rod assembly (9).

- Clamp piston rod (9) flats or hex in a vise to prevent damage to the piston rod.
- Lubricate piston lead-in (L) with hydraulic oil to ensure rubber energizing ring of bidirectional seal (9b) seats properly. Install one edge of rubber energizing ring in deep piston groove and press the rest of the o-ring down while preventing the o-ring from twisting.

NOTICE
Prevent rubber energizing ring from twisting during installation. The bidirectional seal (9b) will not function properly if the rubber energizing ring is twisted.

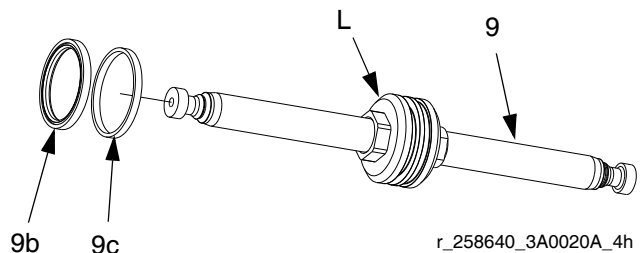

- Install sealing ring of bidirectional seal (9b) over rubber energizing ring and install bearing (9c) in shallow piston groove.

NOTICE
Only expand the sealing ring of bidirectional seal (9b) and bearing (9c) as much as needed to fit over the piston. Damage will occur when the sealing ring or bearing are opened wider than necessary.

- Remove piston assembly (9) from vise and lubricate bidirectional seal (9b) and bearing (9c) with hydraulic oil.

- Lubricate inside of cylinder (1) with hydraulic oil to allow easy installation of piston assembly. Continue to next step if the cylinder hasn't been flushed and there is residual hydraulic oil.

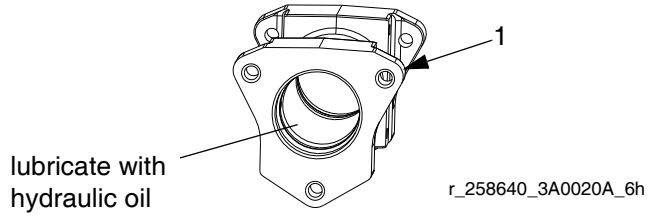

- Install o-rings (2a) on seal housings (2). Lubricate o-rings (2a) with hydraulic oil. Lubricate seals and bearing inside seal housing with hydraulic oil.

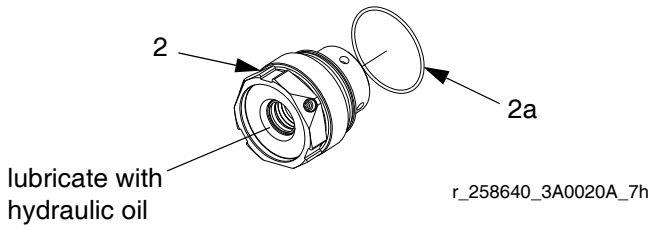

- Install one assembled seal housing (2) on cylinder (1). Torque to 150-160 ft-lbs (203-216 N•m).

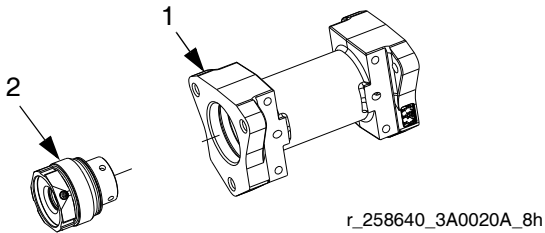

- Install piston rod assembly (9) in cylinder (1) with bidirectional seal (9b) facing away from the cylinder (1). Apply hydraulic oil to bidirectional seal and bearing (9c). Use rubber mallet to tap piston rod assembly until the piston is approximately at the middle of the cylinder.

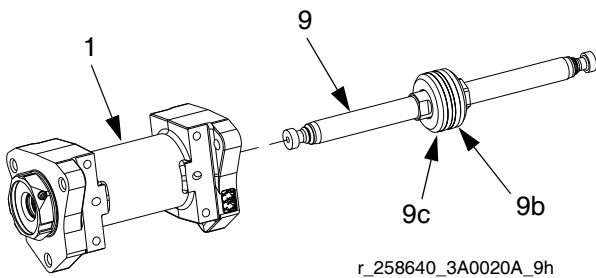

- Install second seal housing (2) on cylinder (1). Torque to 150-160 ft-lbs (203-216 N•m).

NOTE: Use a rubber mallet to gently tap seal housing while turning by hand to start threading the seal housing into cylinder.

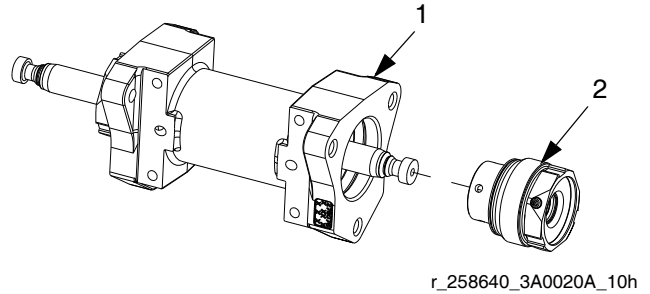

- Apply pipe sealant on two elbow fittings (4) and pipe plugs (5) and install in each seal housing (2).

NOTE: Elbow fitting should be placed in lowest port.

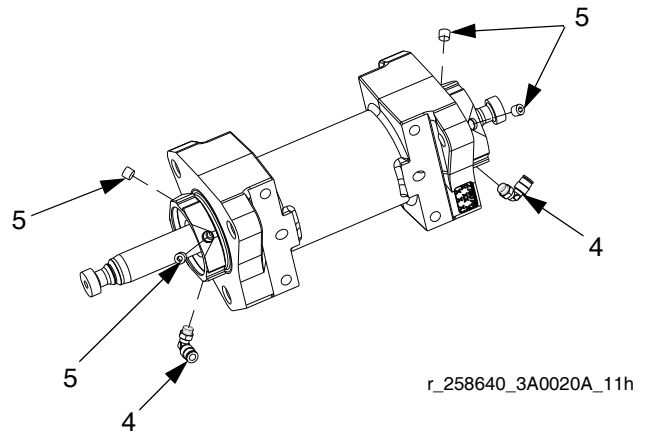

Parts

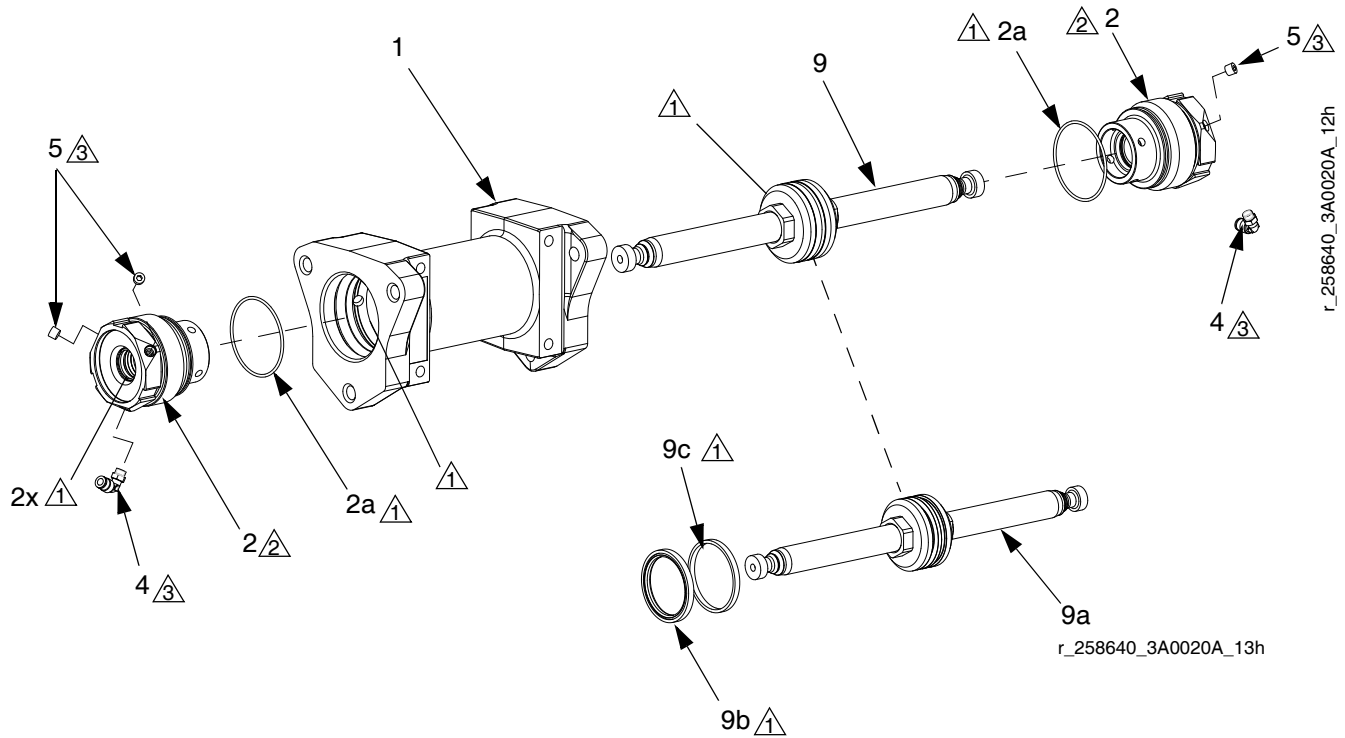

△1 Lubricate seals and surfaces with hydraulic oil.

△2 Torque to 150-160 ft-lbs (203-216 N•m).

△3 Apply pipe sealant.

Ref.	Part	Description	Qty
1	258835	KIT, cylinder, hydraulic	1
2	258768	HOUSING, rod seals, assembly; includes item 2a	2
2a	113570	O-RING	1
4	112698	FITTING, elbow, street	2
5	100139	PLUG, pipe	4
9	258769	ROD, piston, hydraulic, assembly; includes 9a-9c	1
9a		ROD, piston, hydraulic	1
9b◆		SEAL, piston, bidirectional; includes rubber energizing ring and sealing ring	1
9c◆		BEARING, wear, piston	1

◆ Parts included in Kit 258770 (purchase separately).

Dimensions

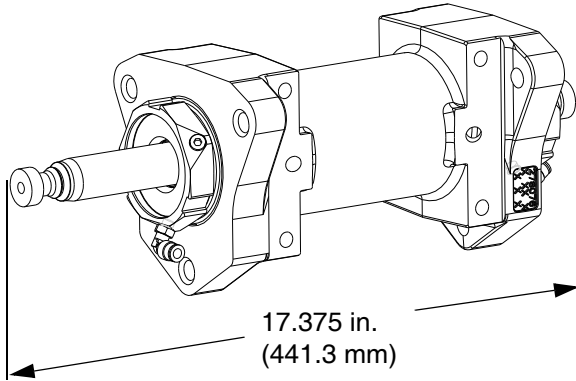

r_258640_3A0020A_14h

Mounting Hole Layout

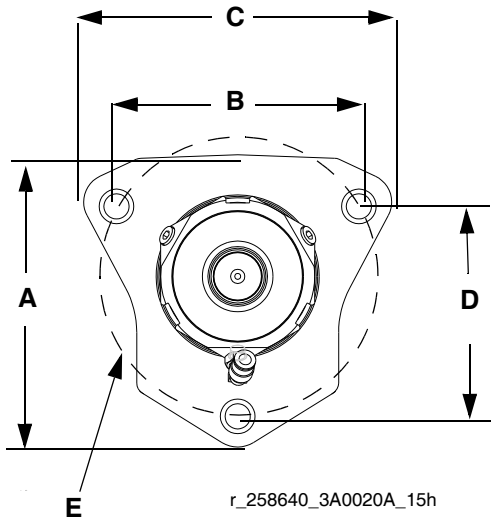

r_258640_3A0020A_15h

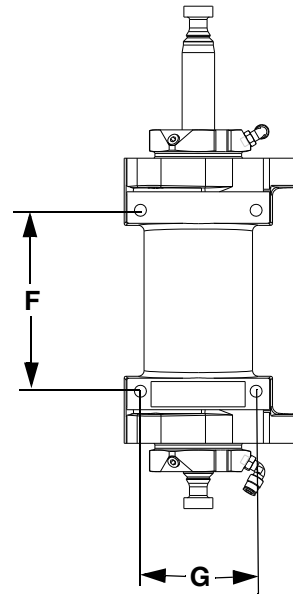

r_258640_3A0020A_17h

A	6.165 in. (156.6 mm)
B	5.114 in. (129.9 mm)
C	6.5 in. (165.1 mm)
D	4.43 in. (112.5 mm)
E	5.906 in. (150 mm) 120° bolt circle
F	6.26 in. (159.0 mm)
G	4 in. (101.6 mm)

Technical Data

Maximum hydraulic working pressure	1200 psi (8.3 MPa, 83 bar)
Maximum fluid temperature	160°F (71°C)
Maximum hydraulic fluid flow	10.3 gpm (38.9 liter/min)
Maximum cycle rate	65 cycles per minute
Hydraulic fluid consumption	1 gal. (3.8 liters) per 6.3 cycles
Effective piston area	6.1 sq. in. (39.2 cm ²)
Piston rod diameter	1.125 in (28.6 mm)
Stroke length	3 in. (76.2 mm)
Thrust at 1200 psi (8.3 MPa, 83 bar)	7300 lbf (32,472 N)
Weight	approx. 40 lb. (18.1 kg)

Graco Standard Warranty

Graco warrants all equipment referenced in this document which is manufactured by Graco and bearing its name to be free from defects in material and workmanship on the date of sale to the original purchaser for use. With the exception of any special, extended, or limited warranty published by Graco, Graco will, for a period of twelve months from the date of sale, repair or replace any part of the equipment determined by Graco to be defective. This warranty applies only when the equipment is installed, operated and maintained in accordance with Graco's written recommendations.

This warranty does not cover, and Graco shall not be liable for general wear and tear, or any malfunction, damage or wear caused by faulty installation, misapplication, abrasion, corrosion, inadequate or improper maintenance, negligence, accident, tampering, or substitution of non-Graco component parts. Nor shall Graco be liable for malfunction, damage or wear caused by the incompatibility of Graco equipment with structures, accessories, equipment or materials not supplied by Graco, or the improper design, manufacture, installation, operation or maintenance of structures, accessories, equipment or materials not supplied by Graco.

This warranty is conditioned upon the prepaid return of the equipment claimed to be defective to an authorized Graco distributor for verification of the claimed defect. If the claimed defect is verified, Graco will repair or replace free of charge any defective parts. The equipment will be returned to the original purchaser transportation prepaid. If inspection of the equipment does not disclose any defect in material or workmanship, repairs will be made at a reasonable charge, which charges may include the costs of parts, labor, and transportation.

THIS WARRANTY IS EXCLUSIVE, AND IS IN LIEU OF ANY OTHER WARRANTIES, EXPRESS OR IMPLIED, INCLUDING BUT NOT LIMITED TO WARRANTY OF MERCHANTABILITY OR WARRANTY OF FITNESS FOR A PARTICULAR PURPOSE.

Graco's sole obligation and buyer's sole remedy for any breach of warranty shall be as set forth above. The buyer agrees that no other remedy (including, but not limited to, incidental or consequential damages for lost profits, lost sales, injury to person or property, or any other incidental or consequential loss) shall be available. Any action for breach of warranty must be brought within two (2) years of the date of sale.

GRACO MAKES NO WARRANTY, AND DISCLAIMS ALL IMPLIED WARRANTIES OF MERCHANTABILITY AND FITNESS FOR A PARTICULAR PURPOSE, IN CONNECTION WITH ACCESSORIES, EQUIPMENT, MATERIALS OR COMPONENTS SOLD BUT NOT MANUFACTURED BY GRACO. These items sold, but not manufactured by Graco (such as electric motors, switches, hose, etc.), are subject to the warranty, if any, of their manufacturer. Graco will provide purchaser with reasonable assistance in making any claim for breach of these warranties.

In no event will Graco be liable for indirect, incidental, special or consequential damages resulting from Graco supplying equipment hereunder, or the furnishing, performance, or use of any products or other goods sold hereto, whether due to a breach of contract, breach of warranty, the negligence of Graco, or otherwise.

FOR GRACO CANADA CUSTOMERS

The Parties acknowledge that they have required that the present document, as well as all documents, notices and legal proceedings entered into, given or instituted pursuant hereto or relating directly or indirectly hereto, be drawn up in English. Les parties reconnaissent avoir convenu que la rédaction du présente document sera en Anglais, ainsi que tous documents, avis et procédures judiciaires exécutés, donnés ou intentés, à la suite de ou en rapport, directement ou indirectement, avec les procédures concernées.

Graco Information

Sealant and Adhesive Dispensing Equipment

For the latest information about Graco products, visit www.graco.com.

For patent information, see www.graco.com/patents.

TO PLACE AN ORDER, contact your Graco distributor, go to www.graco.com and select "Where to Buy" in the top blue bar, or call to find the nearest distributor.

If calling from the US: 800-746-1334

If calling from outside the US: 0-1-330-966-3000

All written and visual data contained in this document reflects the latest product information available at the time of publication. Graco reserves the right to make changes at any time without notice.

This manual contains English. MM 3A0020

Graco Headquarters: Minneapolis
International Offices: Belgium, China, Japan, Korea

GRACO OHIO INC. 8400 PORT JACKSON AVE NW, NORTH CANTON, OH 44720

Copyright 2009, Graco Inc. is registered to ISO 9001

www.graco.com

Revision B, January 2017