

Drywall Feed Pump

3A0245B
EN

- For water-based materials only -
- Not for use in explosive atmospheres -
- Not for use with quick-set materials -



READ ALL WARNINGS AND INSTRUCTIONS
Read all warnings and instructions in this manual.
Save these instructions.

Maximum Working Pressure 2500 psi (17.2 MPa, 172 bar)

- Model 257100: 120V NA ETL
- Model 258906: 240V Euro Multicord
- Model 258907: 110V UK, CE
- Model 262288: 120V NA
- Model 262300: 240V Euro CE Cord

Related Manuals



Repair Manual
3A0246 - English



Pump Manual
3A0912 - English



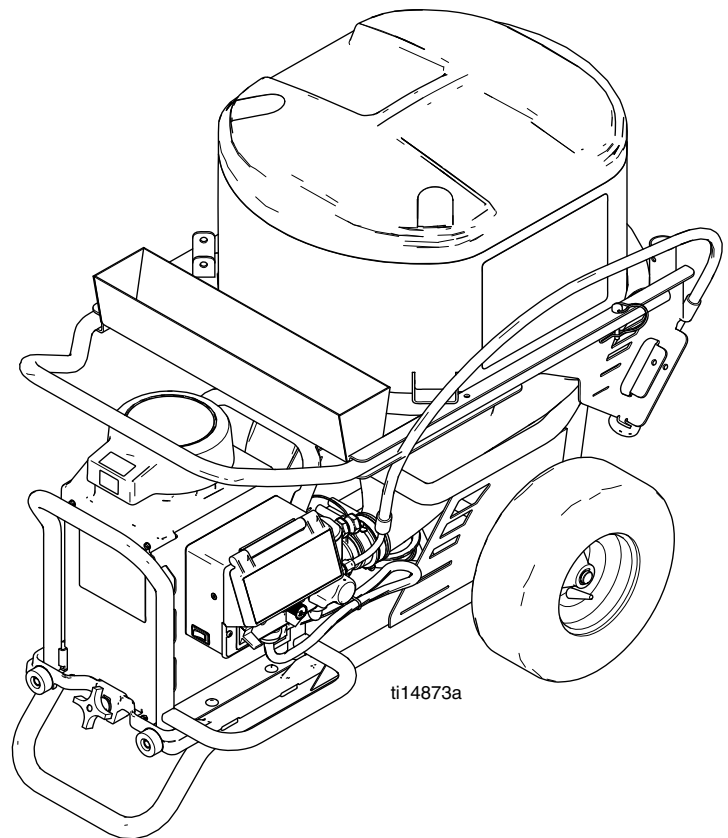

Agency Approvals:

	FC	Canada	ETL Intertek	CE	UK
257100	✓	✓	✓		
258906				✓	✓
258907				✓	
262288	✓	✓			
262300				✓	✓









Warning

The following warnings are for the setup, use, grounding, maintenance, and repair of this equipment. The exclamation point symbol alerts you to a general warning and the hazard symbols refer to procedure-specific risks. When these symbols appear in the body of this manual, refer back to these Warnings. Product-specific hazard symbols and warnings not covered in this section may appear throughout the body of this manual where applicable.

 WARNING	
	<p>ELECTRIC SHOCK HAZARD</p> <p>This equipment must be grounded. Improper grounding, setup, or usage of the system can cause electric shock.</p> <ul style="list-style-type: none"> • Turn off and disconnect power cord before servicing equipment. • Use only grounded electrical outlets. • Use only 3-wire extension cords. • Ensure ground prongs are intact on power and extension cords. • Do not expose to rain. Store indoors.
	<p>SKIN INJECTION HAZARD</p> <p>High-pressure fluid from dispensing device, hose leaks, or ruptured components will pierce skin. This may look like just a cut, but it is a serious injury that can result in amputation. Get immediate surgical treatment.</p> <ul style="list-style-type: none"> • Engage trigger lock when not dispensing. • Do not point dispensing device at anyone or at any part of the body. • Do not put your hand over the fluid outlet. • Do not stop or deflect leaks with your hand, body, glove, or rag. • Follow the Pressure Relief Procedure when you stop dispensing and before cleaning, checking, or servicing equipment. • Tighten all fluid connections before operating the equipment. • Check hoses and couplings daily. Replace worn or damaged parts immediately.
	<p>FIRE AND EXPLOSION HAZARD</p> <p>Flammable fumes, such as solvent and paint fumes, in work area can ignite or explode. To help prevent fire and explosion:</p> <ul style="list-style-type: none"> • Do not dispense flammable or combustible materials near an open flame or sources of ignition such as cigarettes, motors, and electrical equipment. • Material or solvent flowing through the equipment is able to result in static electricity. Static electricity creates a risk of fire or explosion in the presence of material or solvent fumes. All parts of the system, including the pump, hose assembly, dispenser, and objects in and around the work area shall be properly grounded to protect against static discharge and sparks. Use Graco conductive or grounded high-pressure airless material hoses. • Verify that all containers and collection systems are grounded to prevent static discharge. • Connect to a grounded outlet and use grounded extensions cords. Do not use a 3-to-2 adapter. • Do not use a material or a solvent containing halogenated hydrocarbons. • Keep work area well-ventilated. Keep a good supply of fresh air moving through the area. Keep pump assembly in a well ventilated area. • Do not smoke in the work area. • Do not operate light switches, engines, or similar spark producing products in the work area. • Keep area clean and free of material or solvent containers, rags, and other flammable materials. • Know the contents of the materials and solvents being dispensed. Read all Material Safety Data Sheets (MSDS) and container labels provided with the materials and solvents. Follow the material and solvents manufacturer's safety instructions. • Fire extinguisher equipment shall be present and working. • Drywall feed pump generates sparks. When flammable liquid is used in or near the drywall feed pump or for flushing or cleaning, keep unit at least 20 feet (6 m) away from explosive vapors.

⚠️ WARNING

 	<p>MOVING PARTS HAZARD</p> <p>Moving parts can pinch, cut or amputate fingers and other body parts.</p> <ul style="list-style-type: none"> • Keep clear of moving parts. • Do not operate equipment with protective guards or covers removed. • Pressurized equipment can start without warning. Before checking, moving, or servicing equipment, follow the Pressure Relief Procedure and disconnect all power sources.
 	<p>EQUIPMENT MISUSE HAZARD</p> <p>Misuse can cause death or serious injury.</p> <ul style="list-style-type: none"> • Always wear appropriate gloves, eye protection, and a respirator or mask when dispensing. • Do not operate or dispense near children. Keep children away from equipment at all times. • Do not overreach or stand on an unstable support. Keep effective footing and balance at all times. • Stay alert and watch what you are doing. • Do not leave the unit energized or under pressure while unattended. When the unit is not in use, turn off the unit and follow the Pressure Relief Procedure for turning off the unit. • Do not operate the unit when fatigued or under the influence of drugs or alcohol. • Do not kink or over-bend the hose. • Do not expose the hose to temperatures or to pressures in excess of those specified by Graco. • Do not use the hose as a strength member to pull or lift the equipment.
	<p>PRESSURIZED ALUMINUM PARTS HAZARD</p> <p>Use of fluids that are incompatible with aluminum in pressurized equipment can cause serious chemical reaction and equipment rupture. Failure to follow this warning can result in death, serious injury, or property damage.</p> <ul style="list-style-type: none"> • Do not use 1,1,1-trichloroethane, methylene chloride, other halogenated hydrocarbon solvents or fluids containing such solvents. • Many other fluids may contain chemicals that can react with aluminum. Contact your material supplier for compatibility.
	<p>PERSONAL PROTECTIVE EQUIPMENT</p> <p>You must wear appropriate protective equipment when operating, servicing, or when in the operating area of the equipment to help protect you from serious injury, including eye injury, hearing loss, inhalation of toxic fumes, and burns. This equipment includes but is not limited to:</p> <ul style="list-style-type: none"> • Protective eyewear, and hearing protection. • Respirators, protective clothing, and gloves as recommended by the fluid and solvent manufacturer.

Component Identification (Unit)

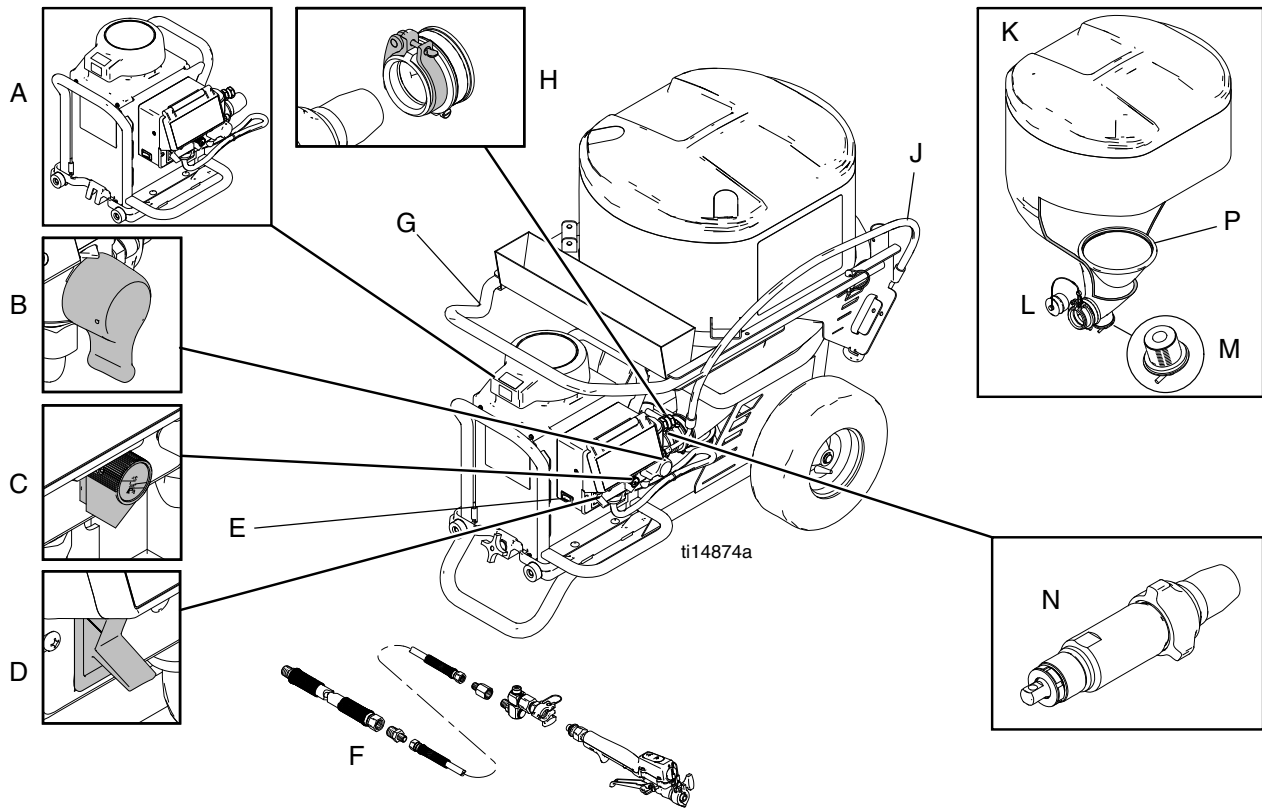



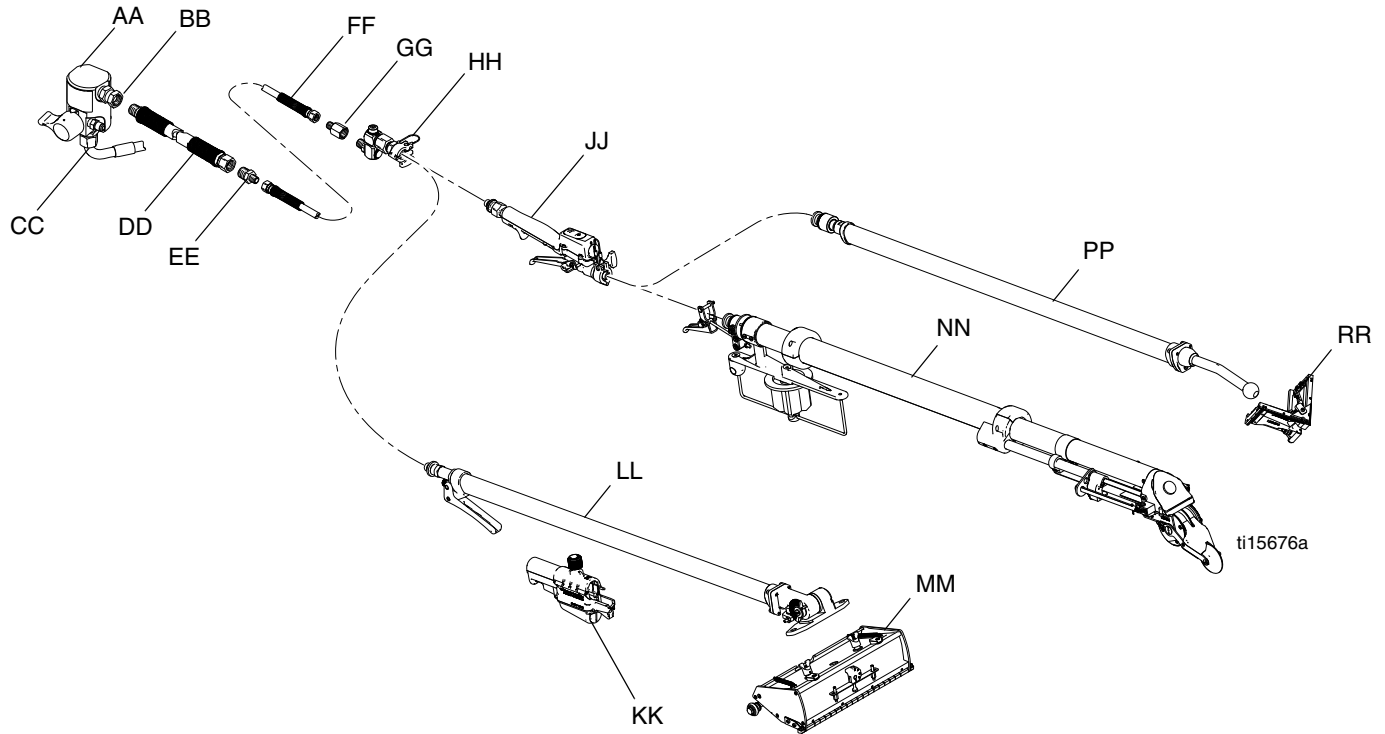

A	Pump Module
B	Prime/Tool Fill/Recirculation Valve/Pressure Relief
C	Flow Control Knob
D	ON/OFF Switch
E	15/20 Amp Switch (North America only)
F	Material Hoses
G	Movable Handle
H	Pump Connector
J	Prime Hose
K	Hopper
L	Hopper Plug
M	Expandable Plug
N	Pump
P	Material Screen



Component Identification (Hoses and Tools)





AA	Fluid Manifold
BB	Fluid Outlet
CC	Fluid Inlet
DD	Hose 1/2 in. x 50 ft (max 150 ft)
EE	Fitting 1/2 in. x 1/4 in.
FF	Hose 1/4 in. x 15 ft
GG	Coupling
HH	Z Swivel with Quick-Connect Clamp
JJ	Inline Valve Controller
KK	Box Slide Controller
LL	Box Tool Handle
MM	Box Tool Head
NN	Tape Tool
PP	Corner Tool Handle
RR	Corner Tool Head

Grounding

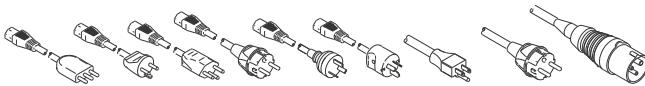
						
GROUNDING INSTRUCTIONS (North America)						
<p>This appliance is rated more than 15 A and is for use on a circuit having a nominal rating of 120 V and is factory equipped with a specific electric cord and plug. No adapter should be used with this appliance. If the appliance must be reconnected for use on a different type of electric circuit, the connection should be made by qualified service personnel; and after the connection, the appliance should comply with all local codes and ordinances.</p> <p>Consult a qualified electrician if there is any doubt as to whether an outlet box is properly grounded.</p>						

						
GROUNDING INSTRUCTIONS (Europe)						
<p>The sprayer must be grounded. Grounding reduces the risk of static and electric shock by providing an escape wire for the electrical current due to static build up or in the event of a short circuit.</p> <p>The sprayer cord includes a grounding wire with an appropriate grounding contact.</p>  <p>The plug must be plugged into an outlet that is properly installed and grounded in accordance with all local codes and ordinances.</p>						

						
<p>Do NOT tamper with relief valve or devices that control maximum flow control during normal operation. Bodily injury and/or damaged to equipment can occur.</p>						

FCC Notice (FCC ID: JHICED1) Model Number: DFS150

This device complies with Part 15 of the FCC rules. Operation is subject to the following two conditions:



- This device may not cause harmful interference.
- This device must accept any interference that may be received, including interference that may cause undesired operation.

Changes or modifications not expressly approved by Graco, Inc. could void the user's authority to operate this equipment.

IC Notice (IC: 4840ACED1)

This product meets the applicable Industry Canada technical specifications/Le présent matériel est conforme aux spécifications techniques applicables d'Industrie Canada.

Pressure Relief Procedure

						
---	---	--	--	--	--	--

1. Turn flow control knob fully counterclockwise to OFF position.

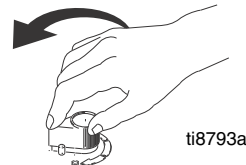

2. Place deflector in hopper or suitable container.

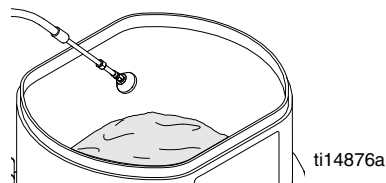

3. Turn prime valve handle to PRESSURE RELIEF position.



4. Display will read "----" when all pressure is relieved. If display does not reach 0, the hose or inline valve are clogged and prime/tool fill/ recirculation valve is plugged.

Setup

1. Turn power switch to OFF and connect power cord.

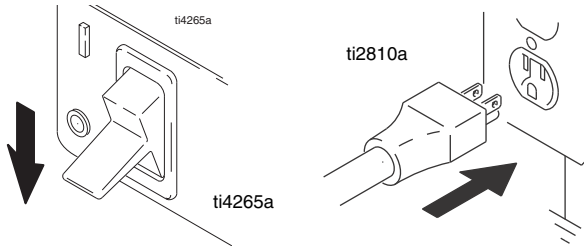

2. Connect material hose (DD) to fluid manifold outlet (BB).

NOTE: Up to 150 ft of 1/2 in. plus 15 ft. x 1/4 in. hose can be connected to the unit. If desired flow rate is not obtainable, reduce hose length or add additional water to material mixture.

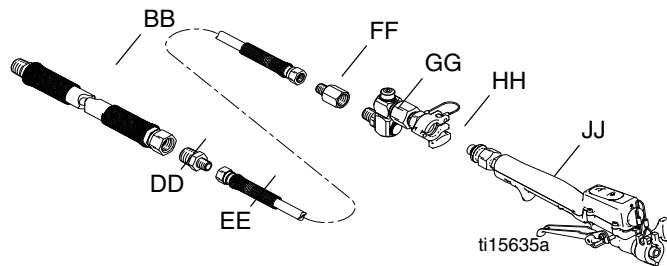

3. Use fitting (EE) to connect to hose (FF) and hose (DD).
4. Use coupling (GG) to connect hose (FF) and Z swivel (HH).
5. Connect Inline Controller Valve (JJ) if taping or finishing corners.
6. Connect selected finishing tool using supplied quick-connect clamps. See **Using Finishing Tools**, page 11.
7. Select 15A/20A setting based on your circuit rating (North America only).

NOTE: 20A setting will produce the best performance.

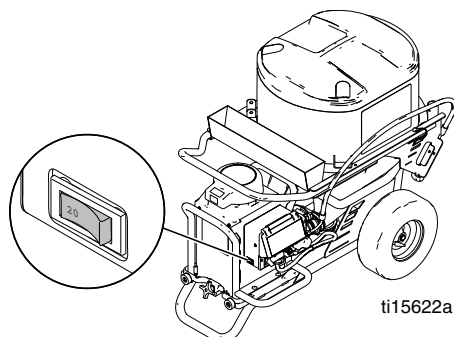

Digital Tracking System (DTS)

Operation Main Menu

Short press to move to next display. Press and hold (5 seconds) to change units or reset.

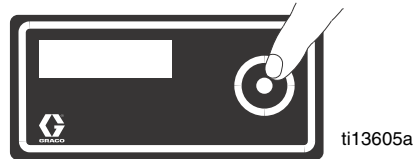

1. Turn flow control knob fully counterclockwise to OFF position. Perform **Pressure Relief Procedure**, page 6.

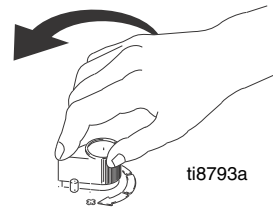

2. Turn power ON. Pressure display appears. Dashes will not appear unless pressure is less than 200 psi (14 bar, 1.4 MPa).

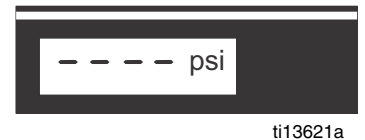
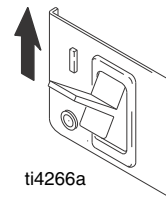

Change Display Units

Press and hold DTS button for 5 seconds to change pressure units (**psi**, **bar**, **MPa**) to desired units. Selection of bar or MPa changes **gallons to liters x 10**. To change display of units, DTS must be in flow control mode and pressure must be at zero.

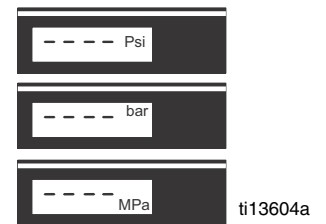
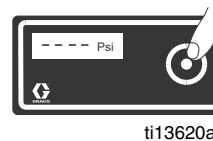

Job Gallons

1. Short press DTS button to move to Job Gallons (or liters x 10).

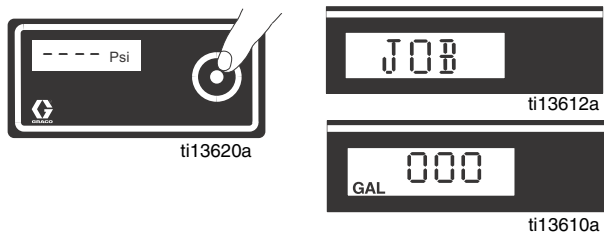

NOTE: JOB scrolls past, then the number of gallons dispensed displays.

2. Press and hold to reset to zero.

Lifetime Gallons

1. Short press DTS button to move to **LIFE** gallons (or liters x 10). **LIFE** scrolls briefly, then the number of gallons dispensed displays.

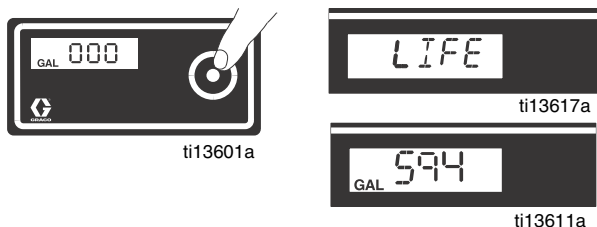

Learn the Controller

This unit uses two different controllers: an inline valve controller for taping and corner finishing, and a box slide controller for box finishing. Each time you change controllers, perform the following steps so the unit can learn the controller.

1. Turn flow control knob fully counterclockwise to OFF position.
2. Push digital display button 3 times until **LEARN** appears on display screen.



3. Pull trigger on controller.

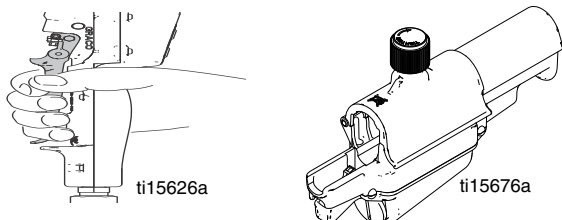

4. **OK** will then appear on display screen (if not, see **Troubleshooting**).



NOTE: You must be facing the unit and be no more than 10 ft away to learn the controller. The unit can only be operated by one learned controller at a time.

Secondary Menu - Stored Data

1. Perform **Pressure Relief Procedure**, see page 6.
2. To access Secondary Menu, make sure flow control knob is turned fully counter-clockwise to the OFF position. Then turn power switch on while holding DTS button down.

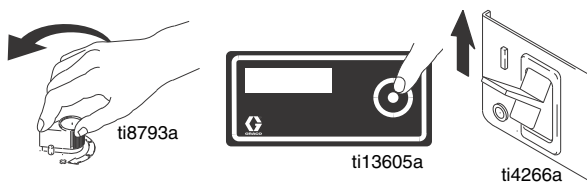

3. **SERIAL NUMBER** scrolls past and then serial number (e.g. 00001) displays.



4. Short press DTS button and **MOTOR HOURS** scrolls past and then total motor run hours are displayed.



5. Short press DTS button. **LAST ERROR CODE** scrolls by and last error code is displayed (e.g. E=07). See **Electrical Problems**, page 19.

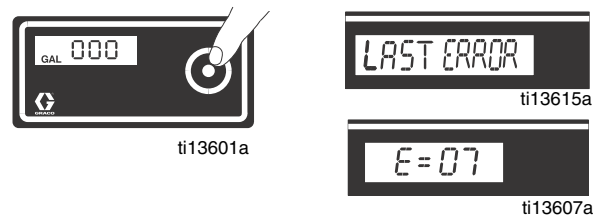

6. Press and hold DTS button to clear error code to zero.



7. Short press to move to SOFTWARE REV.



8. Short press to display number of **GUN TRIGGERS** logged.



9. Short press to enter **BLOCK** mode. Hold DTS button in to block any active outside RF signals in the area other than the current learned controller. The screen will display the number of unwanted signals being blocked. Up to 5 unwanted RF signals can be blocked.



NOTE: To see the number of blocked signals, press and hold the DTS button.

10. Short press to enter **CLEAR** mode. Hold in DTS button to clear all RF signals that were being blocked.



11. Short press to RF ON/OFF mode (this is used for Troubleshooting only). To turn RF off and enter pressure control mode, make sure flow control knob is at zero. Hold DTS button until screen displays **RFOFF**. Turn power switch OFF, then turn back ON. The display will show an asterisk to indicate that it is in pressure control mode.

To return to flow control mode, turn power switch OFF for approximately 45 seconds.



Prime Pump

NOTICE

Do not use with quick-set materials. They can harden inside the unit and hose.

1. Mix material in separate bucket.
2. Add 1-2 gallons (4-8 liters) of material to hopper.

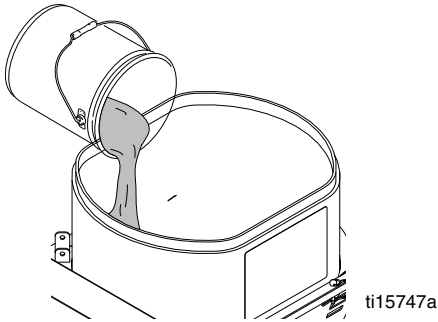

3. Place prime hose deflector into hopper or empty bucket. **NOTE:** Keep deflector shield wet once it is in use.
4. Turn power ON and turn prime valve handle to PRIME. Turn flow control knob clockwise to start pumping.

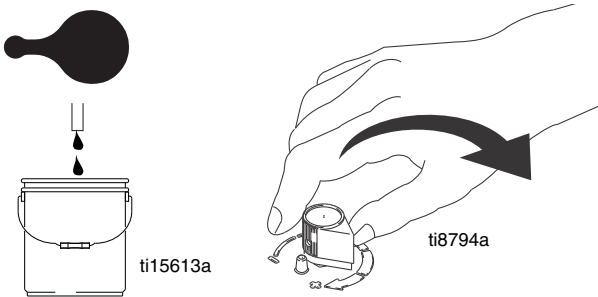

5. Install material screen (P).

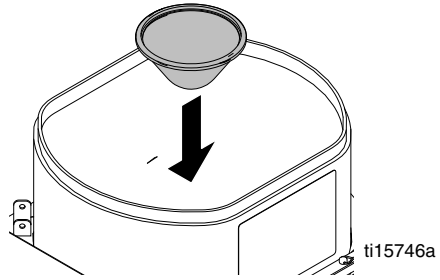

6. Add the remaining material to hopper.



7. After unit is primed, turn prime valve handle to APPLY FINISH position.

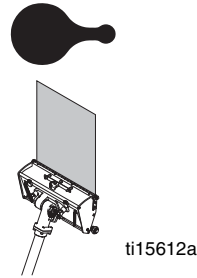

Using Finishing Tools



Corner Finishing

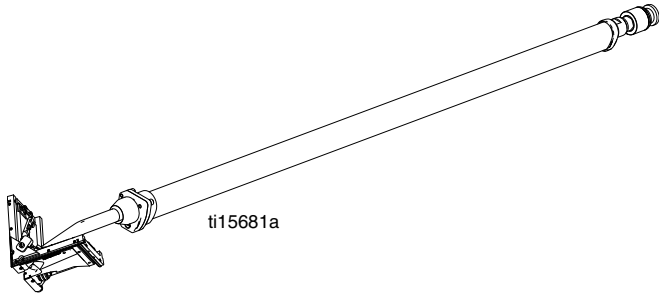

1. Attach corner finisher inlet swivel to inline valve controller (JJ) valve using quick-connect clamp (QC) attached to valve.

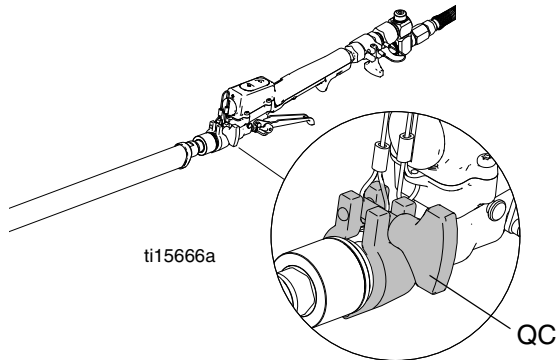

2. Press pin on top of corner finisher head to install onto handle.

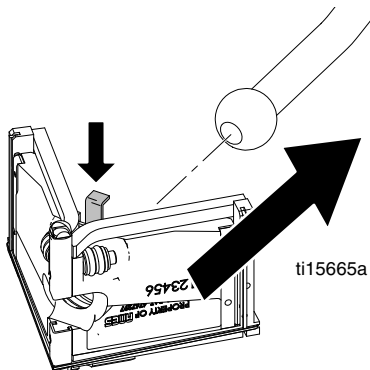

3. Use flow control knob (C) to set material flow rate. Turn flow control knob clockwise to increase material flow.

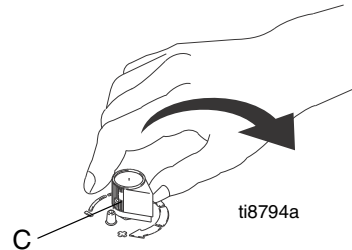

NOTE: Fine flow rate adjustments can be made using “+” and “-” buttons on inline valve controller. Flow rate can only be adjusted relative to position of flow control knob. The fine flow rate can only go down from, and up to the flow control knob setting.

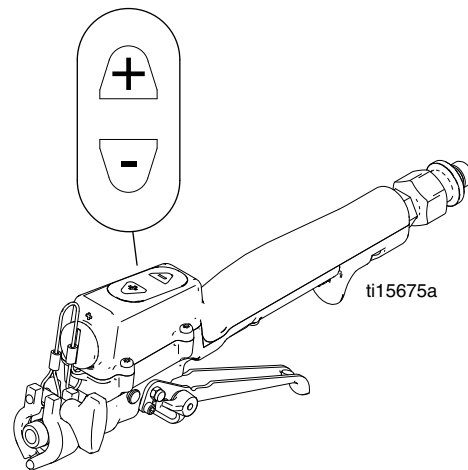

4. Pull trigger and work from top to bottom of vertical angles and from one end to other on ceiling angles.
5. Use drywall knife to detail corner and ceiling angle intersections.

Flat Box Finishing

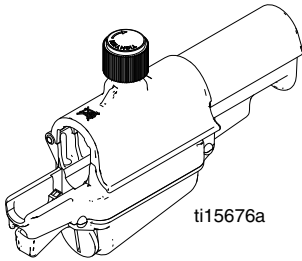

1. Attach male inlet of box finisher to the Z-swivel assembly using quick-connect clamp attached to Z-swivel.
2. Install Box Slide Controller (KK) on box finish handle as shown.

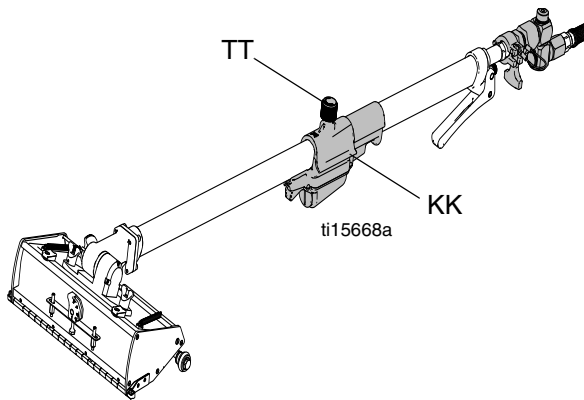

NOTE: The Box Slide Controller Brake (TT) allows the controller to be positioned on the handle. Make sure that the brake is fully loosened when installing the controller on the handle.

3. Install flat finish box on handle using attached wing nuts.
4. Use flow control knob (C) to set material flow rate. Turn flow control knob clockwise to increase material flow.

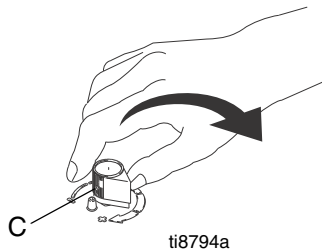

5. Place flat box at end of joint.
6. Pull trigger and lead with handle and draw the tool along the joint.
7. Near middle of the joint, remove flat box from joint surface by applying brake and using a sweeping motion.
8. Adjust hand position and begin again at other end of joint.
9. Again, draw flat box along joint up to previous stopping point and remove box from joint surface by applying brake and using a sweeping motion.
10. Use drywall knife to eliminate seams and overlap.

NOTE: To remove RF Controller, use both thumbs and press down as shown:

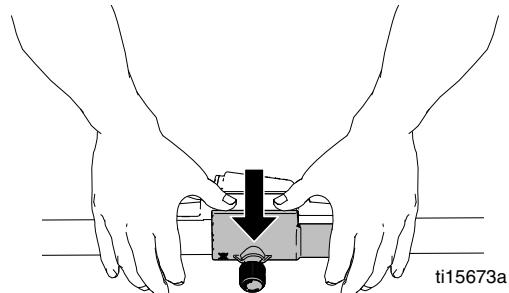

Automatic Taping

1. Remove creaser wheel trigger pin.

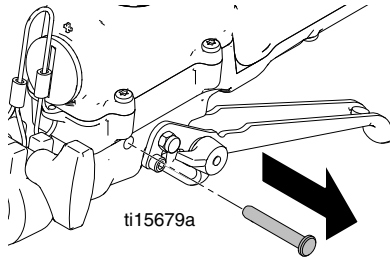

2. Attach taper tool to inline valve.

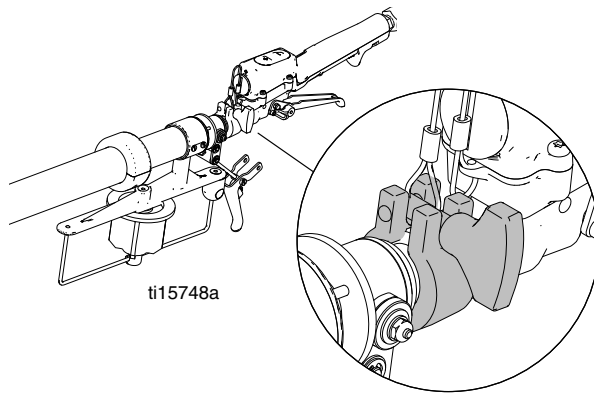

3. Position creaser wheel trigger and insert pin into trigger assembly.

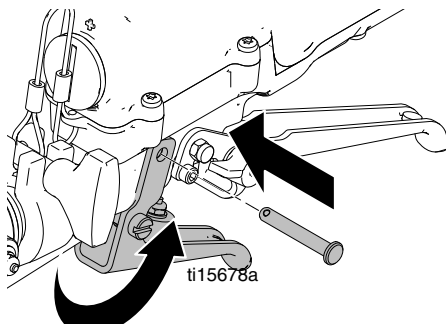

4. Load tape into taper tool.

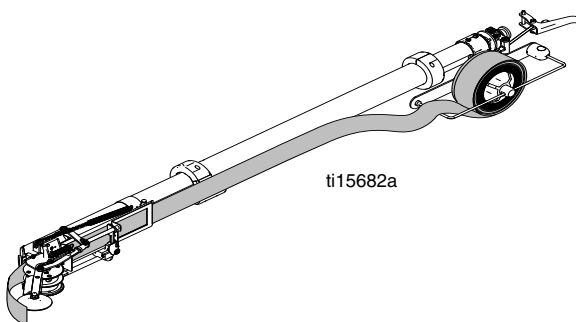

5. Use flow control knob (C) to set material flow rate. Turn flow control knob clockwise to increase material flow.

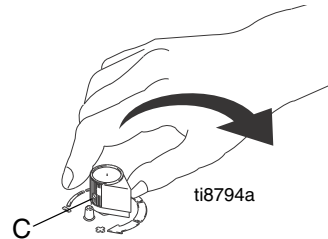

NOTE: Fine flow rate adjustments can be made using “+” and “-” buttons on inline valve controller. Flow rate can only be adjusted relative to position of flow control knob. The fine flow rate can only go down from, and up to the flow control knob setting.

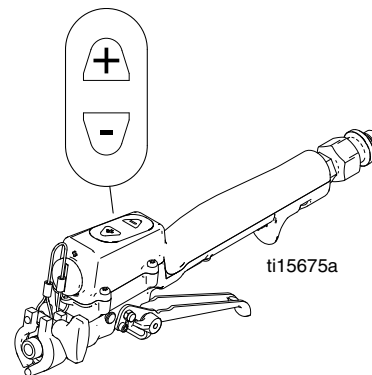

6. Place one hand on taper control tube and one hand on Inline Controller Valve (JJ) while in use.
7. Place tape at bottom of joint (slide tube forward to feed tape).
8. Pull trigger and roll tape over seam keeping taper head wheels in contact with wall.
9. When taper reaches approximately 3 in. (7.5 cm) from end of seam, stop completely and pull tube back to cut tape.
10. Use drywall knife to detail seams and overlap.

NOTE: Clean all tools thoroughly after every use. Use a brush and water to remove all joint compound from tools. Once tools have been cleaned, lightly oil using any light machine oil.

NOTE: When taping ceilings or corner seams, the creaser wheel can be actuated to push the tape into the seam by using the creaser wheel trigger.

Storage



NOTICE

Do not use with quick-set materials. They can harden inside the unit and hose.

1. Perform **Pressure Relief Procedure**, page 6 (prime valve handle in down position). Leave prime valve handle in PRESSURE RELIEF position.



2. Spray water mist on top of any remaining material in the hopper and cover hopper with lid.
3. Cover valve and tool ends to keep joint compound from hardening.
4. Submerge deflector of prime hose in bucket or cover to keep joint compound from hardening.

Cleanup

1. Perform **Pressure Relief Procedure**, page 6 (prime valve handle in down position).
2. Flush unused material from hopper, hose, and prime hose.

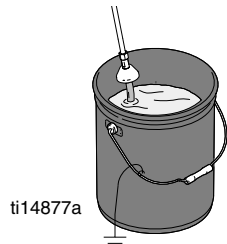
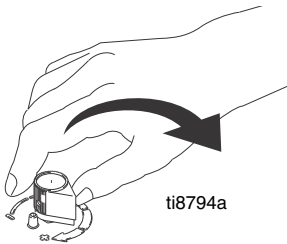

3. Remove remaining material from hopper.
4. Turn pump control fully counter-clockwise to shut pump off.

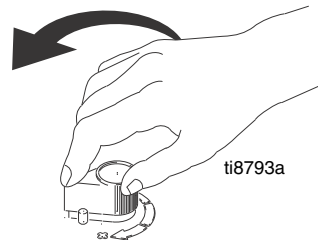

5. Fill material hopper with water and run pump to flush unit. Run water through material hose, tools and drain line thoroughly flush system.



6. Clean all tools.
7. Remove drain plug from hopper. Flush with water. Clean and install drain plug.

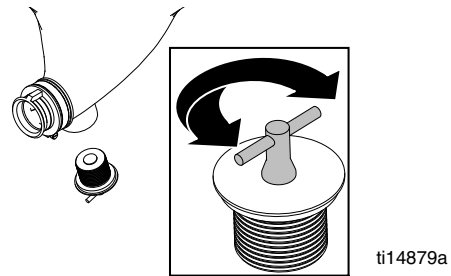

Troubleshooting

Motor Will Not Operate (See flow chart, page 25)

PROBLEM	CAUSE	SOLUTION
Basic fluid flow problems	Flow control knob turned up but unit is not pumping.	Learn the Controller , see page 9. Check battery voltage.
	Flow control knob setting. Motor will not run if at minimum setting (fully counterclockwise).	Slowly increase flow setting to see if motor starts.
	Valve or filter may be clogged.	Relieve pressure and clear clog.
Basic mechanical problems	Frozen material.	Place drywall feed pump in warm area to thaw. Do not start unit until thawed completely.
	Hardened material.	Clean unit.
	Motor. Remove drive housing assembly. Try to rotate fan by hand.	Replace motor if fan won't turn.
Basic electrical problems	Motor control board. Board shuts down and displays error code.	See Control Board Diagnostics .
	No power.	Check power source.
	Extension cord. Check extension cord continuity with volt meter.	Replace extension cord.
	Power supply cord. Inspect for damage such as broken insulation or wires.	Replace power supply cord.
	Check that motor leads are securely fastened and properly mated.	Replace loose terminals; crimp to leads. Be sure terminals are firmly connected. Clean circuit board terminals. Securely reconnect leads.
	ON/OFF Switch.	See Unit Will Not Run , page 25.
	Check all terminals for damage or loose fit.	Replace damaged terminals and reconnect securely.
Battery has no power	Battery voltage depleted.	Replace battery. Graco part number:15X949 (CR123A-3V Lithium)
RF problems		See RF Problems , page 18.
Motor is hot	Digital display shows E=06 	Move unit to shaded, cooler area if possible. Be sure ambient temperature where unit is located is no more than 90°F and unit is not located in direct sun.

Low or Fluctuating Output

PROBLEM	CAUSE	SOLUTION
Low output	Pump is worn or clogged.	Service pump. Check piston and intake valves for wear or obstructions.
	Material hose length. Longer hose length reduces drywall feed pump performance.	Reduce hose length or thin material. Use 20A setting if available.
	Pump hopper adapter connections are loose.	Tighten any loose connections. Replace pump hopper adapter if cracked or punctured.
	Check electrical supply voltage with volt meter. Meter must read: 210-255 Vac for 220-240 Vac models; 85-130 Vac for 100-120 Vac models. Low voltages reduce drywall feed pump performance.	Try a different outlet.
	Extension cord size and length; must be at least 12 awg (1.0 mm ²) wire and no longer than 90 m (295 ft). Longer cord lengths reduce drywall feed pump performance.	Replace with a correct, grounded extension cord.
	Leads from motor to flow control circuit board for damaged or loose wires or connectors. Inspect wiring insulation and terminals for signs of overheating.	Be sure male terminal blades are centered and firmly connected to female terminals. Replace any loose terminal or damaged wiring. Securely reconnect terminals.
	Flow control knob is turned down.	Turn flow control knob fully clockwise. Make sure flow control knob is properly installed to allow full clockwise position.
Plugged prime/tool fill/ recirculation valve	Material has dried and plugged the prime/tool fill/ recirculation valve.	Aim hose into waste pail. Turn prime valve handle from TOOL FILL to PRESSURE RELIEF and then back to TOOL FILL. If valve remains plugged, see Pressure Relief Procedure , page 6.
Plugged hose, swivel, tool, or inline valve	Debris or pack-out in tool, swivel, hose, or inline valve	Check and clean out all flow components. Perform Pressure Relief Procedure , page 6.

Low or Fluctuating Output (continued)

PROBLEM	CAUSE	SOLUTION
Motor runs and pump strokes	No material supply.	Refill hopper and re-prime pump. Clean hopper strainer.
	Loose fittings.	Tighten; use thread sealant or sealing tape on threads if necessary.
	Intake valve ball and piston ball are not seating properly.	Remove intake and piston valves and clean. Check balls and seats for nicks or obstructions; replace if necessary, page 18. Also check piston valve seat for hardened material or nicks and replace if necessary. Clean hopper before using to remove particles that could clog pump.
	Leaking around throat packing nut which may indicate worn or damaged packings.	Replace packing, page 18.
	Pump rod damage.	Repair pump.
Motor runs but pump does not stroke	Displacement pump pin (damaged or missing).	Replace pump pin if missing. Be sure retainer spring (76) is fully in groove all around connecting rod.
	Connecting rod assembly is damaged.	Replace connecting rod assembly.
	Gears or drive housing.	Inspect drive housing assembly and gears for damage. Replace if needed.
Motor intermittently stops while applying material		See RF Problems , page 18.

Electrical Short

PROBLEM	CAUSE	SOLUTION
Building circuit breaker opens as soon as power switch is turned on. CAUTION Any short in any part of the motor power circuit will cause the control circuit to inhibit drywall feed pump operation. Correctly diagnose and repair all shorts before checking and replacing control board.	Electrical wiring insulation damaged, terminals fit loose or are damaged. Also wires between motor control and motor.	Repair or replace damaged wiring or terminals. Securely reconnect all wires.
	Motor armature is shorted.	Replace motor. Inspect windings for burns. Perform motor control board diagnosis.
	Motor control board.	Replace with a new control board if necessary. Perform motor control board diagnosis.
Building circuit breaker opens as soon as unit is plugged into outlet and unit is NOT turned on.	Basic Electrical Problems , see page 15.	Perform necessary procedures.
	For damaged or pinched wires in pressure control.	Replace damaged parts.
Drywall feed pump quits after unit operates for 5 to 10 minutes.	Basic Electrical Problems.	Perform necessary procedures.
	Check electrical supply with volt meter. Meter must read: 210-255 Vac for 220-240 Vac models; 85-130 Vac for 100-120 Vac models.	If voltage is too high, do not operate drywall feed pump until corrected.

RF Problems

PROBLEM	CAUSE	SOLUTION
Unwanted signal will not allow unit to learn the controller.	Unwanted RF signal. Undesired controller is active and in close proximity.	Stop unwanted RF signal by deactivating the controller. Use BLOCK feature on Secondary Menu, see page 8.
RF controller will not learn.	Battery is depleted.	Replace battery (CR123A Lithium 3V).
	Unit has not learned the controller.	Learn the controller , see page 8.
	Controller RF has been blocked.	See CLEAR procedure, page 9.
	Controller is too far away or is not facing the unit.	Move to within 10 ft and face the unit. Hold the controller away from your body.
Interference in RF signal	Signal is out of range.	Reposition the unit. Use optional external remote antenna.

Electrical Problems



Symptom: Unit does not run or stops running.

Perform **Pressure Relief Procedure**; page 6.

- Plug unit into correct voltage, grounded outlet
- Set power switch OFF for 45 seconds and then ON again (this ensures drywall feed pump is in default flow control mode).
- Turn flow control knob clockwise 1/2 turn
- Trigger learned controller
- View digital display



To avoid electrical shock or moving parts hazards when covers are removed for troubleshooting, wait 45 seconds after unplugging power cord for stored electricity to dissipate. Keep clear of electrical and moving parts during troubleshooting procedures.

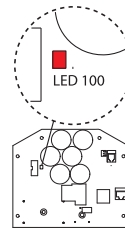

If no digital display is available, use the control board status light to troubleshoot problems. turn ON/OFF switch to OFF, remove control cover and then turn power back ON. Observe status light. Blinking LED total count equals digital error code (example: two blinks equals E=02).

TYPE OF PROBLEM	WHAT TO CHECK	HOW TO CHECK
Drywall feed pump does not run at all	See flow chart, page 25.	
Digital display is blank		
Control board status light never lights		
Drywall feed pump does not run at all	Check transducer or transducer connections.	<ol style="list-style-type: none"> 1. Make sure there is no pressure in the system (see Pressure Relief Procedure, page 6). Check fluid path for clogs. 2. Make sure a minimum of 50 ft of hose is connected to the unit. 3. Set drywall feed pump to OFF and disconnect power to drywall feed pump. 4. Check transducer and connections to control board. 5. Disconnect transducer from control board socket. Check that transducer and control board contacts are clean and secure. 6. Reconnect transducer to control board socket. Connect power, turn unit ON, set pump to PRIME position, and turn control knob 1/2 turn clockwise. If drywall feed pump does not run properly, turn unit OFF and go to next step. 7. Install new transducer. Connect power, turn unit ON, set pump to PRIME position, and turn control knob 1/2 turn clockwise. Replace control board if drywall feed pump does not run properly.
Digital display shows E=02		
Control board status light blinks 2 times repeatedly		

TYPE OF PROBLEM	WHAT TO CHECK	HOW TO CHECK
Drywall feed pump does not run at all Digital display shows E=03 <div style="text-align: center; font-size: 2em; font-family: monospace;">E=03</div>	Check transducer or transducer connections (control board is not detecting a pressure signal).	<ol style="list-style-type: none"> 1. Turn unit OFF and disconnect power. 2. Check transducer and connections to control board. 3. Disconnect transducer from control board socket. Check to see if transducer and control board contacts are clean and secure.
Control board status light blinks 3 times repeatedly		<ol style="list-style-type: none"> 4. Reconnect transducer to control board socket. Connect power, turn unit ON, set pump to PRIME position, and turn control knob 1/2 turn clockwise. If drywall feed pump does not run, turn unit OFF and go to next step. 5. Connect a confirmed working transducer to control board socket. 6. Connect power, turn unit ON, set pump to PRIME position, and turn control knob 1/2 turn clockwise. If drywall feed pump runs, install new transducer. Replace control board if unit does not run. 7. Check transducer resistance with ohmmeter (less than 9k ohm between red and black wires and 3-6k ohm between green and yellow wires).

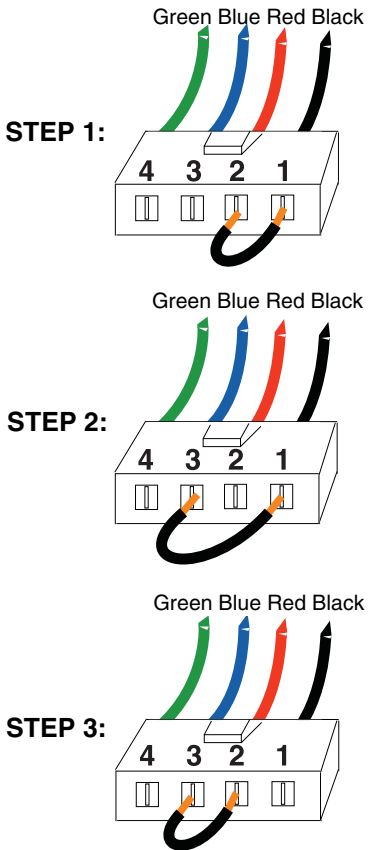
TYPE OF PROBLEM	WHAT TO CHECK	HOW TO CHECK
<p>Drywall feed pump does not run at all</p> <p>Digital display shows E=05</p> <p style="text-align: center; font-size: 2em;">E = 05</p>	<p>Control is commanding motor to run but motor shaft does not rotate. Possibly locked rotor condition, an open connection exists between motor and control, there is a problem with motor or control board.</p>	<ol style="list-style-type: none"> 1. Remove pump pin and try to run unit. If motor runs, check for locked or frozen pump or drive train. If unit does not run, continue to step 2. 2. Turn unit OFF and disconnect power to drywall feed pump. 3. Disconnect motor connector(s) from control board leads. Check that motor connector and control board connectors are clean and secure. 4. Turn unit OFF and spin motor fan 1/2 turn. Restart drywall feed pump. If unit runs, replace control board. If unit does not run, continue to step 5. 5. Perform Spin Test: Test at large 4-pin motor field connector. Disconnect fluid pump from unit. Test motor by placing a jumper across pins 1 & 2. Rotate motor fan at about 2 revolutions per second. A cogging resistance to motion should be felt at the fan. The motor should be replaced if no resistance is felt. Repeat for pin combinations 1 & 3 and 2 & 3. Pin 4 (the green wire) is not used in this test. If all spin test is positive, continue to step 6.
<p>Control board status light blinks 5 times repeatedly</p>		 <p>The diagrams illustrate the spin test procedure on a 4-pin connector. The pins are labeled 4, 3, 2, and 1 from left to right. The wires are color-coded: Green (4), Blue (3), Red (2), and Black (1).</p> <ul style="list-style-type: none"> STEP 1: A jumper wire connects pins 1 and 2. STEP 2: A jumper wire connects pins 1 and 3. STEP 3: A jumper wire connects pins 2 and 3.

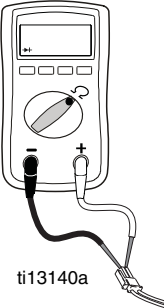
TYPE OF PROBLEM	WHAT TO CHECK	HOW TO CHECK
Drywall feed pump does not run at all Digital display shows E=05 	Control is commanding motor to run but motor shaft does not rotate. Possibly locked rotor condition, an open connection exists between motor and control, there is a problem with motor or control board, or motor amp draw is excessive.	6. Perform Field Short Test: Test at large 4-pin motor field connector. There should not be continuity from pin 4, the ground wire, and any of the remaining 3 pins. If motor field connector tests fail, replace motor. 7. Check Motor Thermal Switch: Unplug thermal wires. Set meter to ohms. Meter should read 6.2k ohms.
Control board status light blinks 5 times repeatedly		 <p>ti13140a</p>

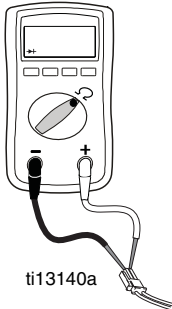
TYPE OF PROBLEM	WHAT TO CHECK	HOW TO CHECK
<p>Drywall feed pump does not run at all</p> <p>Digital display shows E=06</p> <p style="text-align: center; font-size: 2em;">E=06</p> <p>Control board status light blinks 6 times repeatedly</p>	<p>Is motor overheating?</p>	<p>NOTE: Motor must be cooled down for the test.</p> <ol style="list-style-type: none"> 1. Allow unit to cool. If unit runs when cool, correct cause of overheating. Keep unit in cooler location with good ventilation. If unit still does not run, follow Step 1. 2. Check fan and air intake. 3. Check motor thermal switch. 4. Check thermal device leads (yellow wires) at control board. 5. Disconnect thermal device connector from control board socket. Make sure contacts are clean and secure. <p>Check Motor Thermal Switch: Unplug thermal wires. Set meter to ohms. Meter should read 6.2k ohms. If reading is not correct, replace motor.</p> <div style="text-align: center;">  <p>ti13140a</p> </div> <ol style="list-style-type: none"> 6. Replace motor control board.
<p>Drywall feed pump does not run at all</p> <p>Digital display shows E=09</p> <p style="text-align: center; font-size: 2em;">E=09</p> <p>Control board status light blinks 9 times repeatedly</p>	<p>Control is not receiving a motor position sensor signal</p>	<ol style="list-style-type: none"> 1. Turn power OFF. 2. Disconnect motor position sensor and inspect for damage at connectors. 3. Reconnect sensor. 4. Turn power ON. If error continues, replace motor.
<p>Drywall feed pump does not run at all</p> <p>Digital display shows E=10</p> <p style="text-align: center; font-size: 2em;">E=10</p> <p>Control board status light blinks 10 times repeatedly</p>	<p>Check to see if control board is over heating.</p>	<ol style="list-style-type: none"> 1. Make sure motor air intake is not blocked. 2. Make sure fan has not failed. 3. Make sure control board is properly connected to back plate and that conductive thermal paste is used on power components. 4. Replace control board. 5. Replace motor.

Unit Will Not Shut Off

Perform **Pressure Relief Procedure**; page 6.
 Leave prime valve handle open and power switch OFF.

Troubleshooting Procedure:

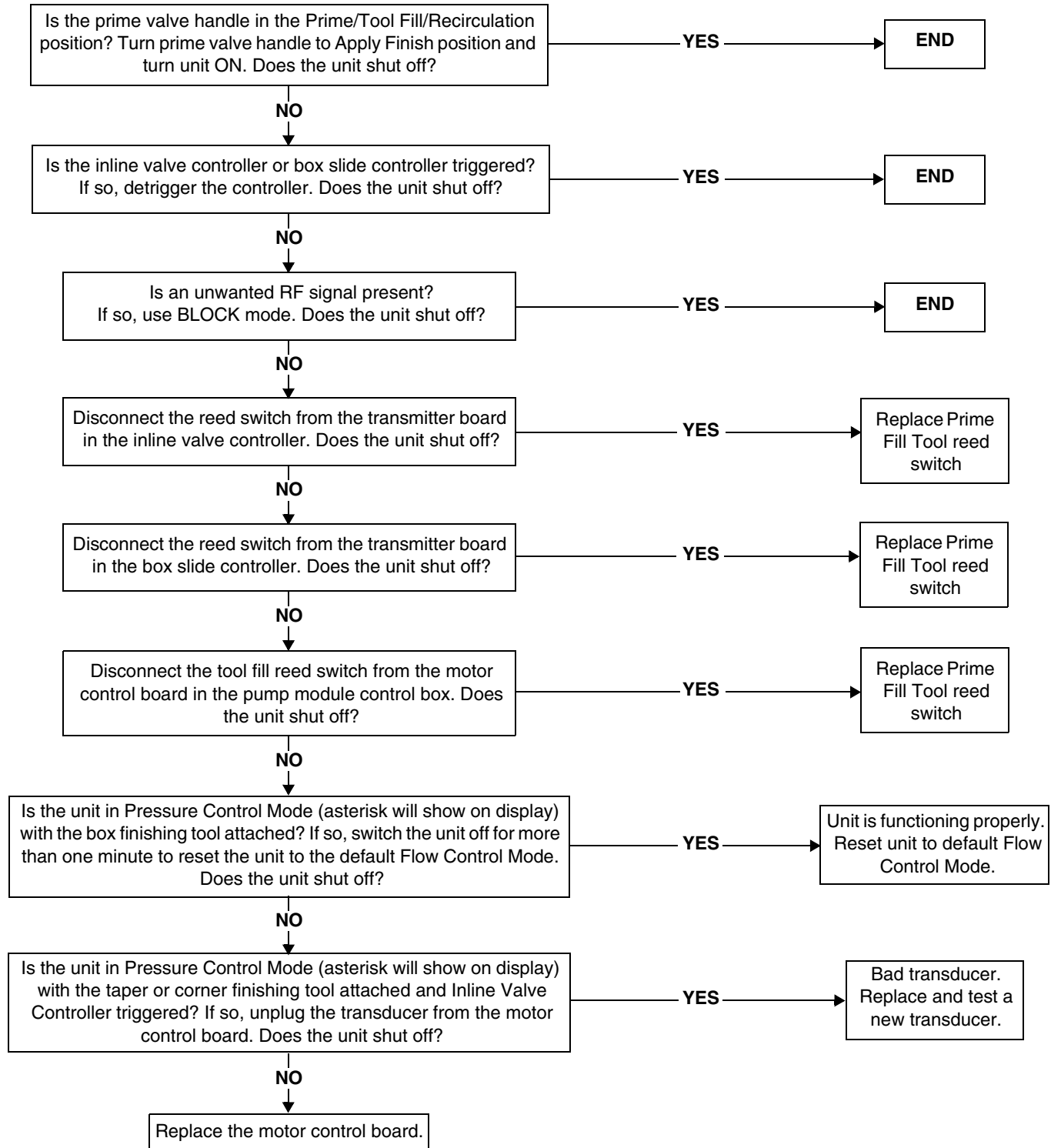

Unit Will Not Run
(See following page for steps)

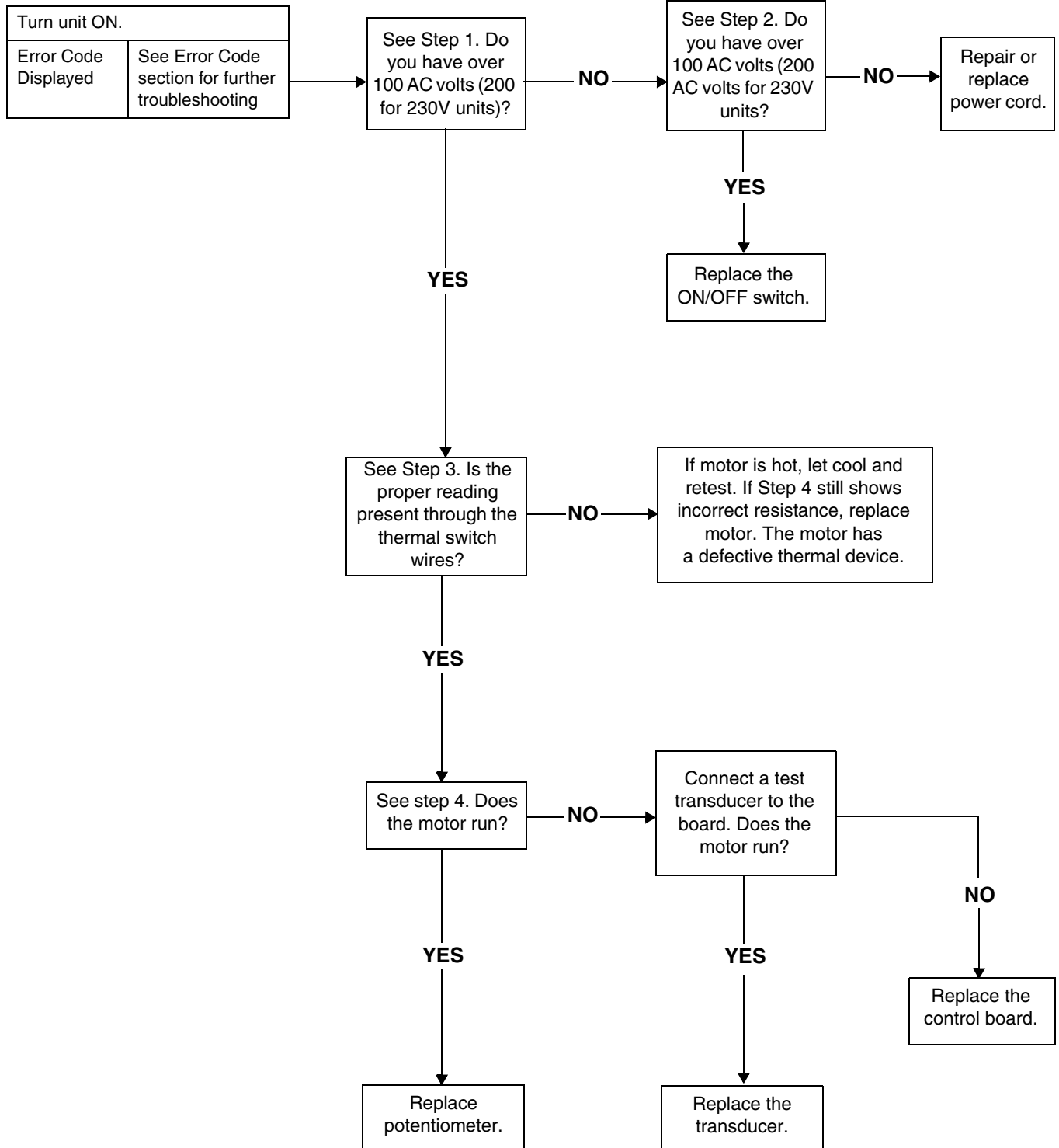

Unit Will Not Run - Steps: 100-120 VAC NA Units

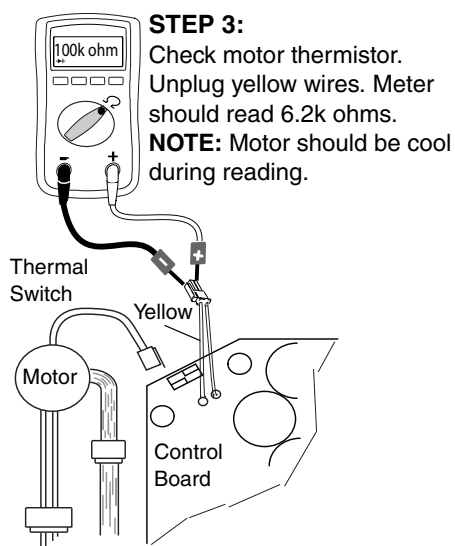
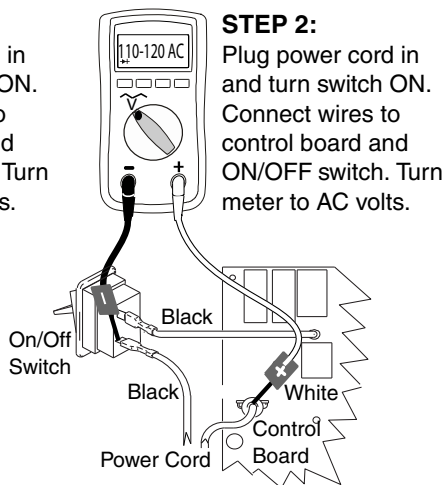
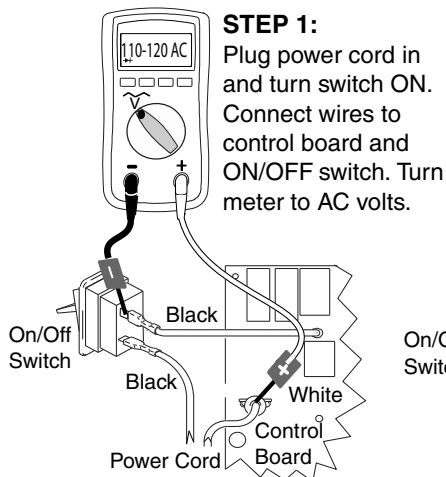

STEP 4: Plug power cord in and turn switch ON. Disconnect potentiometer. Use nonmagnetic screwdriver to short pins.

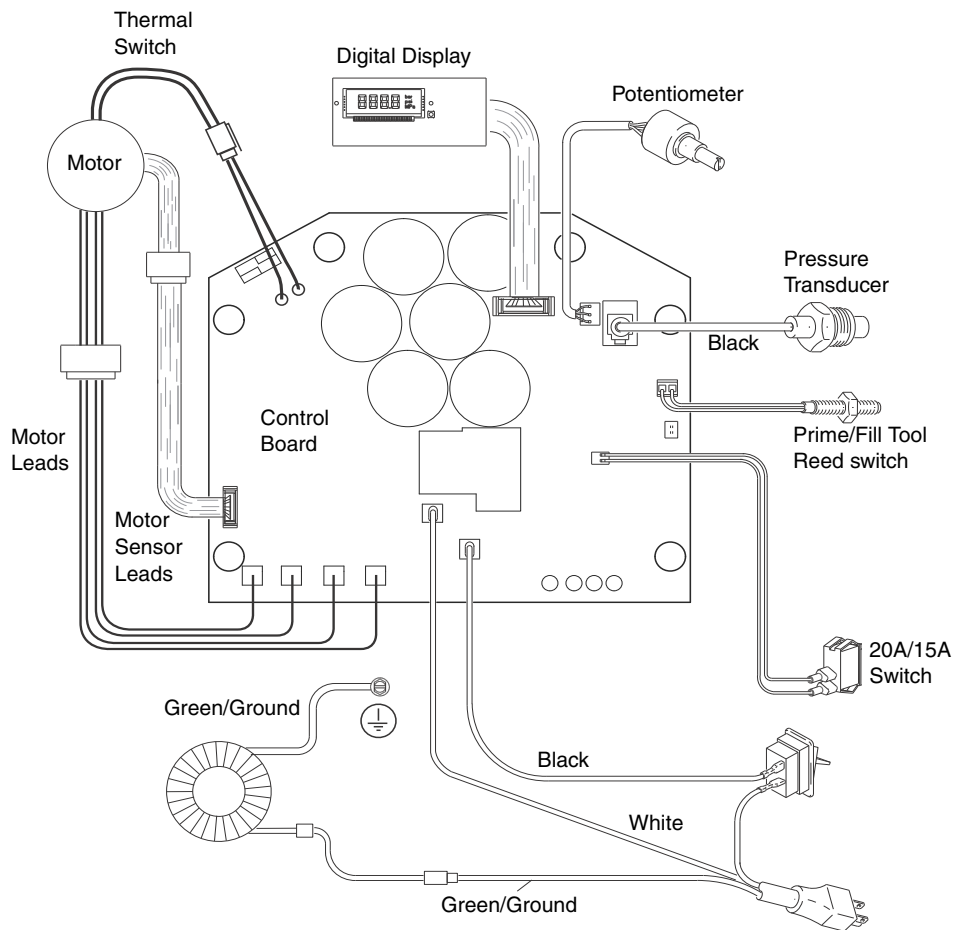
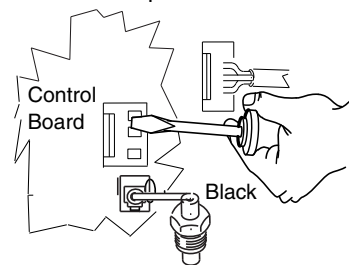

ti14889a

Unit Will Not Run - Steps: 100-120 VAC UK

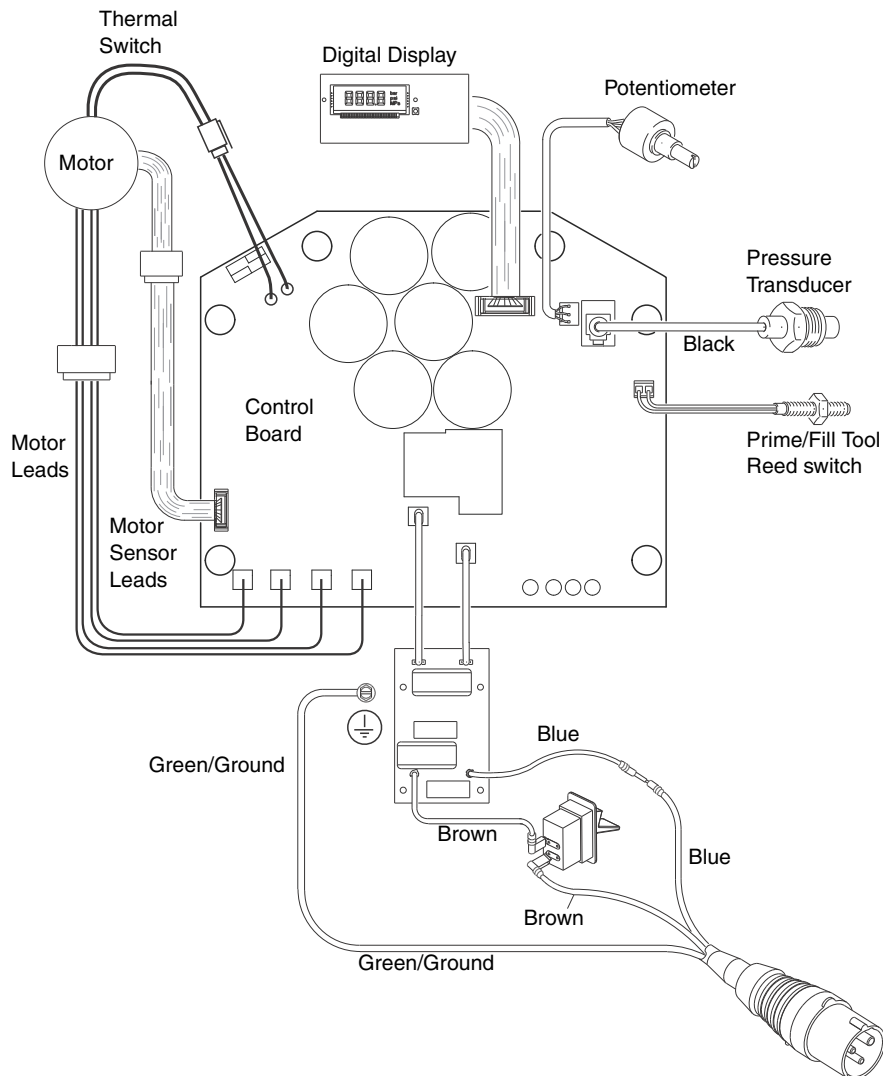
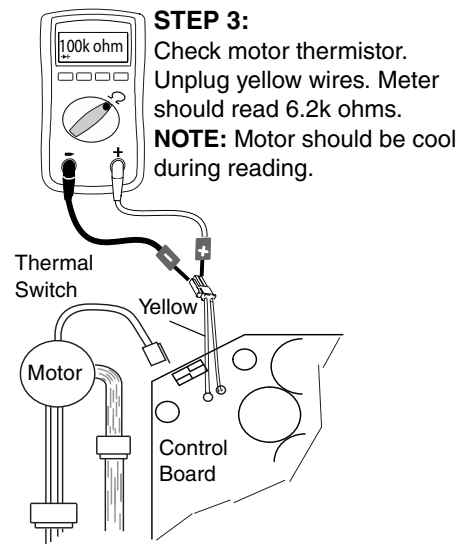
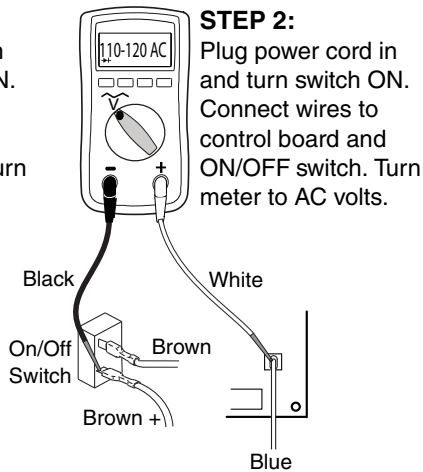
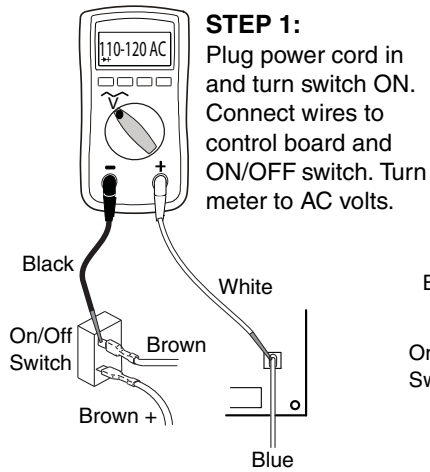

STEP 4:
Plug power cord in and turn switch ON. Disconnect potentiometer. Use nonmagnetic screwdriver to short pins.

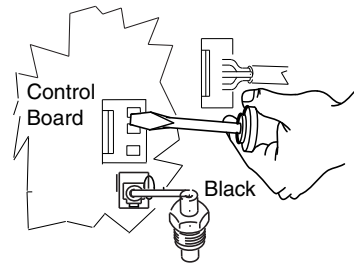

ti15686a

Unit Will Not Run - Steps: 220-240 VAC Units

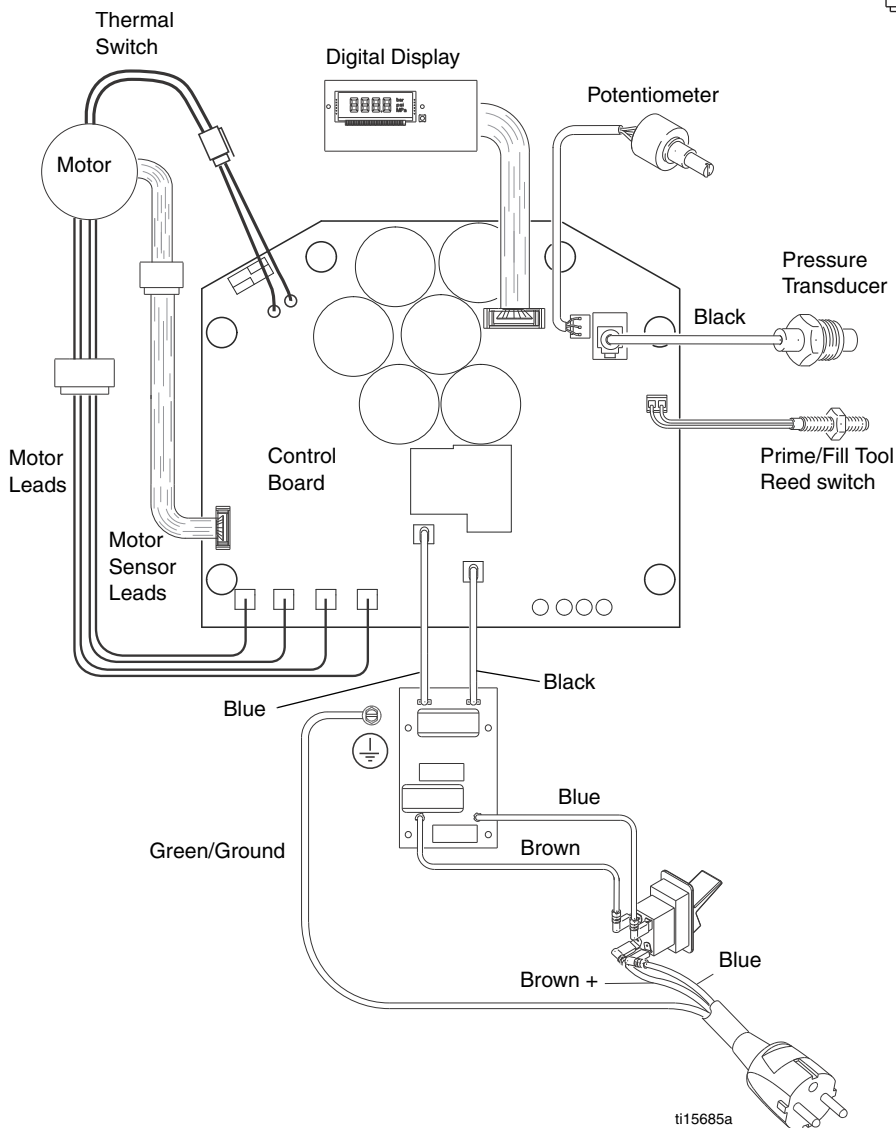
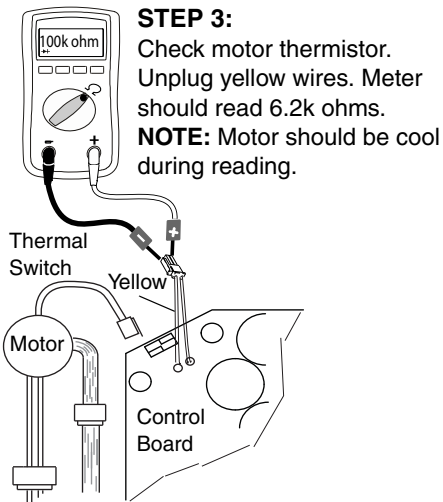
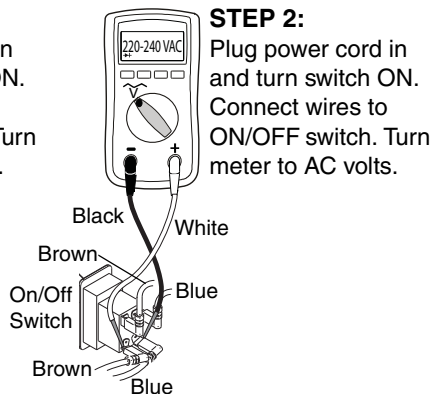
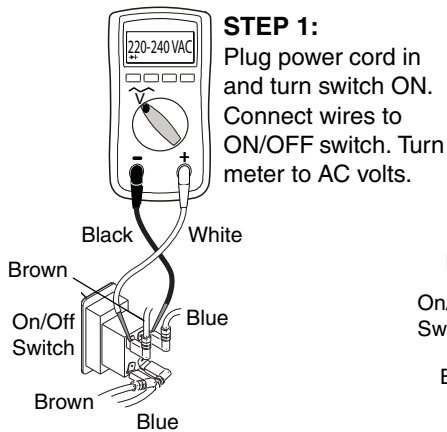

STEP 4:
 Plug power cord in and turn switch ON. Disconnect potentiometer. Use nonmagnetic screwdriver to short pins.

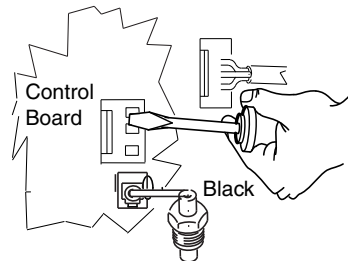

Technical Data (Unit)

Power requirements:	
Models 257100, 262288	100-120 VAC, 60 Hz, 15/20A
Models 258906, 262300	220-240 VAC, 50 Hz, 10A
Model 258907	100-120 VAC, 50/60 Hz, 15A
Motor HP (W)	2.5 (1864)
Maximum fluid working pressure	2500 psi (17.2 MPa, 172 bar)
Hopper capacity	25 gallons (95 liters)
Maximum delivery with texture material	Up to 1.5 gpm (5.7 lpm) - varies depending on material
Maximum hose length	150 ft of 1/2 in. hose plus 15 ft of 1/4 in. hose
Fluid outlet size	1/2 in. NPT female swivel
Dimensions	
Length	40 to 55 in. (102 cm to 140 cm) with handle
Width	22 in. (56 cm)
Height	31 in. (79 cm)
Weight (with hoses and applicator)	196 lb (89 kg)
Wetted parts	Buna-N, aluminum, brass, polyethylene, neoprene, stainless steel, nickel-plated carbon steel, fluoroelastomer, nickel-plated iron, wool felt, tungsten carbide, PTFE, nylon, zinc-plated carbon steel, paper, PVC, UHMWPE, leather, rubber
Sound data for drywall feed pump	
Sound pressure level *	80.0 dB(A)
Sound power level †	94.7 dB(A)
* Measured while dispensing at 1 m	
† Measured per ISO-3744	

Technical Data (Pump)

Maximum working pressure	2500 psi (172 bar, 17.2 MPa)
Fluid outlet size	1/2 npt(f)

Notes

Graco Standard Warranty

Graco warrants all equipment referenced in this document which is manufactured by Graco and bearing its name to be free from defects in material and workmanship on the date of sale to the original purchaser for use. With the exception of any special, extended, or limited warranty published by Graco, Graco will, for a period of twelve months from the date of sale, repair or replace any part of the equipment determined by Graco to be defective. This warranty applies only when the equipment is installed, operated and maintained in accordance with Graco's written recommendations.

This warranty does not cover, and Graco shall not be liable for general wear and tear, or any malfunction, damage or wear caused by faulty installation, misapplication, abrasion, corrosion, inadequate or improper maintenance, negligence, accident, tampering, or substitution of non-Graco component parts. Nor shall Graco be liable for malfunction, damage or wear caused by the incompatibility of Graco equipment with structures, accessories, equipment or materials not supplied by Graco, or the improper design, manufacture, installation, operation or maintenance of structures, accessories, equipment or materials not supplied by Graco.

This warranty is conditioned upon the prepaid return of the equipment claimed to be defective to an authorized Graco distributor for verification of the claimed defect. If the claimed defect is verified, Graco will repair or replace free of charge any defective parts. The equipment will be returned to the original purchaser transportation prepaid. If inspection of the equipment does not disclose any defect in material or workmanship, repairs will be made at a reasonable charge, which charges may include the costs of parts, labor, and transportation.

THIS WARRANTY IS EXCLUSIVE, AND IS IN LIEU OF ANY OTHER WARRANTIES, EXPRESS OR IMPLIED, INCLUDING BUT NOT LIMITED TO WARRANTY OF MERCHANTABILITY OR WARRANTY OF FITNESS FOR A PARTICULAR PURPOSE.

Graco's sole obligation and buyer's sole remedy for any breach of warranty shall be as set forth above. The buyer agrees that no other remedy (including, but not limited to, incidental or consequential damages for lost profits, lost sales, injury to person or property, or any other incidental or consequential loss) shall be available. Any action for breach of warranty must be brought within two (2) years of the date of sale.

GRACO MAKES NO WARRANTY, AND DISCLAIMS ALL IMPLIED WARRANTIES OF MERCHANTABILITY AND FITNESS FOR A PARTICULAR PURPOSE, IN CONNECTION WITH ACCESSORIES, EQUIPMENT, MATERIALS OR COMPONENTS SOLD BUT NOT MANUFACTURED BY GRACO. These items sold, but not manufactured by Graco (such as electric motors, switches, hose, etc.), are subject to the warranty, if any, of their manufacturer. Graco will provide purchaser with reasonable assistance in making any claim for breach of these warranties.

In no event will Graco be liable for indirect, incidental, special or consequential damages resulting from Graco supplying equipment hereunder, or the furnishing, performance, or use of any products or other goods sold hereto, whether due to a breach of contract, breach of warranty, the negligence of Graco, or otherwise.

FOR GRACO CANADA CUSTOMERS

The Parties acknowledge that they have required that the present document, as well as all documents, notices and legal proceedings entered into, given or instituted pursuant hereto or relating directly or indirectly hereto, be drawn up in English. Les parties reconnaissent avoir convenu que la rédaction du présente document sera en Anglais, ainsi que tous documents, avis et procédures judiciaires exécutés, donnés ou intentés, à la suite de ou en rapport, directement ou indirectement, avec les procédures concernées.

Graco Information

For the latest information about Graco products, visit www.graco.com.

TO PLACE AN ORDER, contact your Graco distributor or call 1-800-690-2894 to identify the nearest distributor.

*All written and visual data contained in this document reflects the latest product information available at the time of publication.
Graco reserves the right to make changes at any time without notice.*

For patent information, see www.graco.com/patents.

Original instructions. This manual contains English. MM 3A0245

Graco Headquarters: Minneapolis

International Offices: Belgium, China, Japan, Korea

GRACO INC. P.O. BOX 1441 MINNEAPOLIS, MN 55440-1441

Copyright 2010, Graco Inc. is registered to ISO 9001

www.graco.com

Revised August 2012