

G-Force Hot Water Pressure Washer

3A0592E
EN

*-For high pressure, hot water cleaning-
-For outdoor use only-*

IMPORTANT SAFETY INSTRUCTIONS



Read all warnings and instructions in this manual.
SAVE THESE INSTRUCTIONS.

Model	Horse Power and Motor Brand	Maximum Working Pressure		
		PSI	MPa	bar
3540GHW	390 cc Honda	3500	24.13	241.3

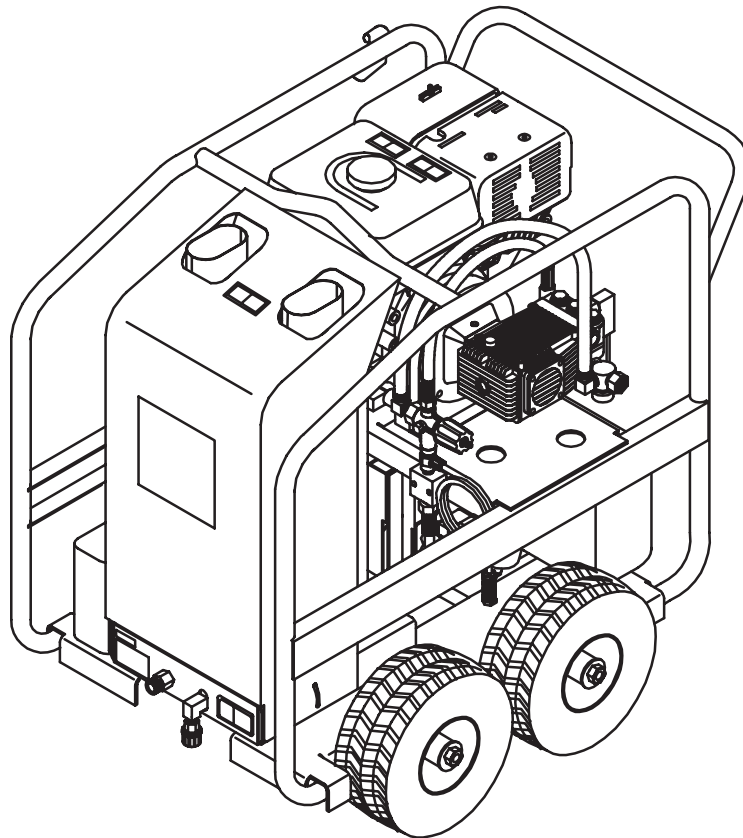

PROVEN QUALITY. LEADING TECHNOLOGY.

CONTENTS

Important	3	Pump.....	16
Spray Precautions	3	Nozzles.....	16
Fire & Ventilation Precautions	4	Couplers.....	16
Carbon Monoxide Hazard	4	Fuel Water Separator	16
Detergent Cleaning Precautions	4	Burner Air Adjustment.....	16
Burn Hazard	4	Leaks.....	16
Miscellaneous Safety Precautions	5	Winterizing.....	17
Adjustment Precautions	5	Troubleshooting	18
Personal Protective Equipment	5	Pump Service: 3540 GHW Model Pressure Washers	20
Component Identification	6	Valves	20
Installation & Preparation instructions	7	Pumping Section.....	20
Attire.....	7	Servicing Plungers.....	20
Setup.....	7	Servicing V-packings.....	20
Engine/burner Fuel Tank.....	8	Notes	21
Nozzle Review	8	Pressure Washer - Parts	22
Dual Lance Assembly With Adjustable Pressure.....	9	262298- Model 3540 GHW	22
Dual Lance Connection.....	9	Engine/Pump Assembly - Parts	24
Water Supply.....	10	Item 17 (For Use With Model 3540 GHW).....	24
Unloader.....	11	Pump Assembly - Parts	26
Thermal Relief Valve	11	16E609 (For Use With Model 3540 GHW).....	26
Pre-start Inspection Procedures	11	Unloader/Manifold Assembly - Parts	28
Operating Instructions	12	Item 8 (For Use With Model 3540 GHW).....	28
Priming The Pump.....	12	Heat Exchanger/EMF Assembly - Parts	30
Direct Feed:.....	12	Item 31 (For Use With Model 3540 GHW).....	30
Start-up/cold Water Operation.....	13	Bracket/Electrical Box Assembly - Parts	32
Start-up/hot Water Operation.....	14	Item 28 (For Use With Model 3540 GHW).....	32
Cleaning With Detergents.....	15	Decal Placement - Parts	35
Shutdown	15	262298 - Model 3540 GHW	35
Storage & Maintenance instructions	16	Notes	36
Engine.....	16	Technical Data	37
		Graco Standard Warranty	38

THIS SPARK IGNITION SYSTEM COMPLIES WITH
CANADIAN ICES-002.
CE SYSTÈME D'ALLUMAGE PAR ÉTINCELLE EST
CONFORME À LA NORME NMB-002 DU CANADA.

The following warnings are for the setup, use, grounding, maintenance, and repair of this equipment. The exclamation point symbol alerts you to a general warning and the hazard symbols refer to procedure-specific risks. When these symbols appear in the body of this manual, refer back to these Warnings. Product-specific hazard symbols and warnings not covered in this section may appear throughout the body of this manual where applicable.

WARNING



IMPORTANT

The engine exhaust from this product contains chemicals known to the State of California to cause cancer, birth defects or other reproductive harm.

This product contains one or more chemicals known to the State of California to cause cancer and birth defects or other reproductive harm.

The following is required by California State law, Section 4442 of the California Public Resources Code. Other states may have similar laws. Federal laws apply on federal lands.

- A spark arrester must be added to the muffler of this engine if it is to be used on any forest covered, brush covered or grass covered unimproved land. The arrester must be maintained in effective working order by the operator.
- See your engine or equipment dealer for spark arrester muffler options.



SPRAY PRECAUTIONS

Risk of injection or severe cutting injury. If an accident does occur and the spray appears to have penetrated the skin, seek emergency medical care. Do not treat as a simple cut. If you are using cleaning agents, be prepared to tell a physician exactly what kind.

- Keep clear of nozzle.
- Do not direct discharge stream at persons or pets.
- Only trained operators should use this product. When operating this unit, basic precautions should always be observed.
- Keep away from the spray. Because of the high pressure and velocity of the spray, fluids can penetrate the skin, causing serious injury.
- Never point the gun at yourself or anyone else. Never put your hand, fingers or body directly over the spray nozzle. Always keep operating area clear of all persons. Use extreme caution when operating near children.
- Always wear protective goggles when operating the unit to shield the eyes from flying debris and detergents. Protective equipment such as rubber suits gloves and respirators are advisable, especially when using cleaning detergents. Use extreme caution when operating near children.
- Stay alert-watch what you are doing. Do not operate the unit when fatigued or under the influence of alcohol or drugs.
- Never squeeze the trigger unless securely braced. The thrust from the water traveling through the nozzle may be powerful enough to cause the operator to lose balance if unprepared. Do not overreach or stand on unstable support. Wet surfaces can be slippery, wear protective foot gear and keep good footing and balance at all times. Never trigger the gun while on a ladder or roof.
- Caution should be used when directing spray toward fragile materials such as glass. Shattering could result in serious injury.
- Always hold on firmly to the gun/wand assembly when starting and operating the unit. Failure to do so can cause the wand to fall and whip dangerously. Never operate the gun with the trigger wired in the open position. To prevent accidental discharge, the trigger gun should be securely locked when not in use.

WARNING

- Do not direct spray on or into electrical installations of any kind! This includes electrical outlets, light bulbs, fuse boxes, transformers, etc. Severe electrical shock may occur.
- Even after you shut off the unit, there is high pressure water left in the pump, hose and gun until you release it by triggering the gun. Before removing the spray nozzle or servicing the unit, always shut off the unit and trigger the gun to release trapped pressure.

FIRE & VENTILATION PRECAUTIONS

- This unit was designed for outdoor use only. Never operate this unit in an enclosed area. Always make certain there is adequate air (oxygen) for combustion as well as ventilation to prevent the presence of poisonous carbon monoxide gases. Beware of poorly ventilated areas or exhaust fans which can cause inadequate combustion or engine overheating.
- Never operate this unit in the presence of flammable vapors or combustible dust, gases or other combustible materials. (A spark may cause an explosion or fire.) When servicing this machine, be especially careful to properly dispose of any flammable materials. Do not spray flammable liquids.
- Do not smoke while filling engine fuel tank
- Never fill the engine fuel tank while the unit is running or hot. Allow the engine to cool two minutes before refueling.
- Do not refuel indoors or in a poorly ventilated area.
- Always refuel slowly to avoid the possibility of spilled fuel which may cause a risk of fire.
- Do not operate the unit if gasoline is spilled. Wipe unit clean and move the unit away from the spill. Avoid creating any ignition until the gasoline has evaporated.
- Do not store the unit near an open flame or any equipment such as a stove, furnace, water heater, etc., which utilizes a pilot light or devices which can create a spark.
- This pressure washer has a safety relief device which should never be altered, modified, removed or made inoperative. If the device fails, replace immediately with only genuine manufacturer replacement part.

CARBON MONOXIDE HAZARD

Exhaust contains poisonous carbon monoxide, which is colorless and odorless. Breathing carbon monoxide can cause death.

- Do not operate in an enclosed area.

DETERGENT CLEANING PRECAUTIONS

- Do not use solvents or highly corrosive detergents or acid type cleaners with this pressure washer.
- Know your detergent. Be prepared to tell a physician exactly what you are using in the event of an emergency. Read the Material Safety Data Sheet (MSDS) provided with your detergent and all detergent labels. Follow all appropriate instructions regarding preparation use, safety and transportation. Keep all detergents out of the reach of children.
- Do not use this pressure washer to dispense hazardous detergents.
- Do not alter the detergent injection feature in any manner not prescribed in this manual. Use only genuine replacement parts for necessary repairs.

BURN HAZARD

Equipment surfaces and fluid that's heated can become very hot during operation. To avoid severe burns:

- Do not touch hot fluid or equipment.

⚠ WARNING



MISCELLANEOUS SAFETY PRECAUTIONS

- Never allow children or adolescents to operate this unit.
- Read and follow all handling, operations, maintenance and safety instructions listed in this manual and the engine operator's manual that accompanies this unit, and provide such information to anyone who will be operating this unit.
- In freezing temperatures, the unit must always be warm enough to ensure there is no ice formation in the pump. Do not start this unit if it has been transported in an open or under heated vehicle without first allowing the pump to thaw.
- When connecting the water inlet to the water supply mains, local regulations of your water company must be observed. In some areas the unit must not be connected directly to the public drinking water supply. This is to ensure that there is no feedback of the detergents into the water supply. (Direct connection is permitted if a back flow preventer is installed.)
- Do not allow any part of your body or the high pressure hose to make contact with the muffler. Avoid dragging the hose over an abrasive surface such as cement. This causes wear and eventual rupturing.
- High pressure hoses should be inspected daily for signs of wear. If evidence of failure exists, promptly replace all suspect hoses to prevent the possibility of injury from the high pressure spray. If a hose or fitting is leaking, never place your hand directly on the leak.
- Do not operate the unit without all protective covers in place.
- Never run the unit with the governor disconnected or operate at excessive speeds.
- To reduce the risk of injury, maintain a safe distance for persons while operating this unit. Close supervision is necessary when operating the unit near children.
- Do not leave pressurized unit unattended. Shut off the unit and release trapped pressure before leaving.
- Do not move the unit by pulling on the hose.



ADJUSTMENT PRECAUTIONS

- Never alter or modify the equipment, be sure any accessory items and system components being used will withstand the pressure developed. Use only genuine parts for repair of your pressure washer. Failure to do so can cause hazardous operating conditions and will void warranty.
- Never make adjustments to the machinery while it is connected to the engine without first removing the ignition cable from spark plug. Turning the machinery over by hand during adjustment or cleaning might start the engine and machinery with it, causing serious injury to the operator.
- Know how to stop the pressure washer and bleed pressures quickly. Be thoroughly familiar with controls.
- Before servicing the unit; turn the unit off, relieve the water pressure, and allow the unit to cool down. Do not make repairs while unit is running. Service in a clean, dry, flat area. Block the wheels to prevent the unit from moving.
- Follow the maintenance instructions specified in this manual.



PERSONAL PROTECTIVE EQUIPMENT

You must wear appropriate protective equipment when operating, servicing, or when in the operating area of the equipment to help protect you from serious injury, including eye injury, hearing loss, inhalation of toxic fumes, and burns. This equipment includes but is not limited to:

- Protective eye wear, and hearing protection.
- Respirators, protective clothing, and gloves as recommended by the detergent manufacturer.

Component Identification

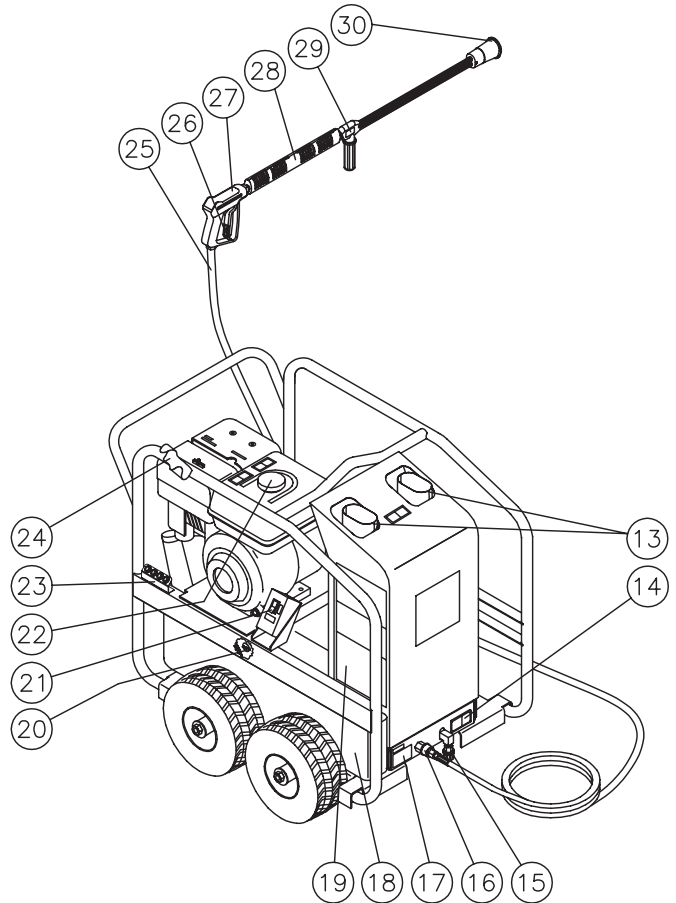
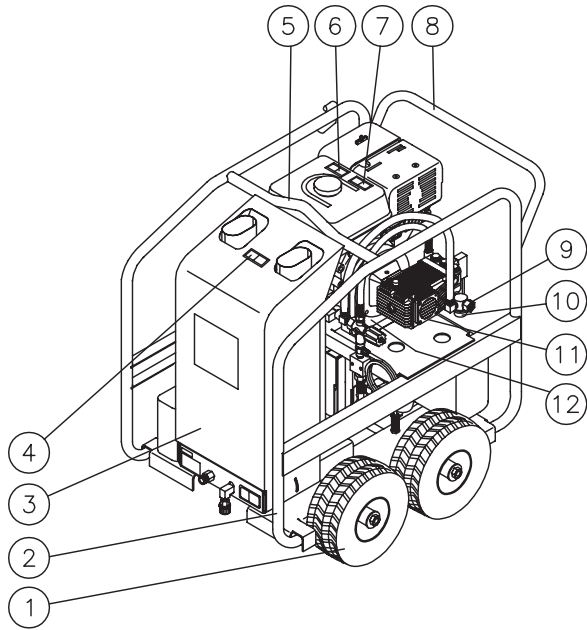

Item	Description
1.	Pneumatic Wheels
2.	Protective Rollcage
3.	Protective Cover
4.	Decal-Warning: Hot Surfaces
5.	Center Balanced Lifting Eye
6.	Decal-Caution: Cool before Refueling
7.	Decal- Warning: Allow to Cool
8.	Convenient Push/Pull Handle
9.	Water Inlet
10.	Water Strainer
11.	High Pressure Pump
12.	Beltguard
13.	Heat Exchanger Exhaust
14.	Decal-Warning: Do Not Modify Plumbing
15.	Coil Drain Assembly

Item	Description
16.	High Pressure Outlet
17.	Decal-Data Plate
18.	Burner Fuel Tank
19.	Decal-Warning/Caution/Operating
20.	Air Shutter Adjusting Arm
21.	Burner On/Off Switch
22.	Engine Gasoline Tank
23.	Nozzle Holder
24.	Wand Holder
25.	High Pressure Hose
26.	Trigger Safety Lock
27.	Trigger Gun
28.	Insulated Lance
29.	Adjustable Pressure Dual Lance
30.	Nozzle

INSTALLATION & PREPARATION INSTRUCTIONS

Attire



Proper attire is essential to your safety. It is advised to utilize whatever means necessary to protect eyes, ears, and skin. Additional safety attire (such as respiratory mask) may be required when using detergent cleaning agents with this washer.

Setup

This unit should only be placed on a level surface to ensure proper lubrication for the engine and water pump while operating.

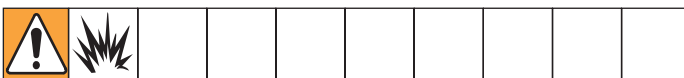

Do not use unit in an area:

- with insufficient ventilation.
- where there is evidence of oil or gas leaks.
- where flammable gas vapors may be present.

This unit has multiple ignition sources that could cause an explosion or fire.

Be certain to block the wheels to prevent the unit from moving while operating.



Do not allow the unit to be exposed to rain, snow or freezing temperatures. If any part of the unit becomes frozen, excessive pressure may build up in the unit which could cause it to burst resulting in possible serious injury to the operator or bystanders.

Pump oil level should be checked before each use. Check the oil level indicator on the pump crankcase. Make certain the oil is in the center of the oil sight glass. If the level appears to be low, fill with recommended pump oil.

INSTALLATION & PREPARATION INSTRUCTIONS

Engine/Burner Fuel Tank



Review "Fire & Ventilation Precautions" pg. 4, before fueling.

Locate the Safety Decals on your unit and heed their warnings.

Gasoline Engines: When filling tank, gasoline fuel should be a minimum of 85 octane. Do Not mix oil with gasoline. Gasoline fuel should be purchased in quantities that maybe be used within 30 days. Use of clean fresh lead-free gasoline is recommended. Leaded gasoline may be used if lead-free is unavailable. Do Not use gasoline containing methanol or alcohol.

Burner Fuel: When filling tank, use No. 1 or No. 2 fuel oil/diesel or kerosene.

Check the engine oil level before starting the engine. (See engine manual.)

Refer to the engine manual supplied with this unit for proper engine adjustment procedures.

Review the engine manual accompanying this pressure washer for correct engine start-up and maintenance procedures.

Nozzle Review



Various nozzles may be quick-connected into the end of the wand to change the spray pattern or use the detergent feature. When using Quick Connects (Q.C.), be certain the connection is securely locked. If not, the high pressure water may shoot the nozzle from the wand, causing severe injury or serious damage.

To determine spray fan, refer to the actual number stamped on the nozzle. The first two digits indicate the spray fan in degrees, i.e.; 0=0°, 15=15°, 25=25°, 40 = 40°, 65=detergent/low pressure.

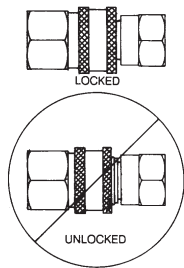

The 0° nozzle (RED): This is a blasting nozzle. It delivers a very concentrated stream of water. Be cautious when using the straight narrow stream. It is not recommended for use on painted or wood surfaces, or items attached with adhesive backings. Uses: Removing weeds from sidewalk cracks, stubborn stains from concrete, masonry, aluminum and steel, caked mud from equipment, and cleaning lawn mower undersides.

The 15° nozzle (YELLOW): This is a chiseling nozzle. The spray should be directed at a 45° angle to the surface and used like a scraper to remove paint, grease and dirt. Uses: Surface preparation (removing mildew stains and paint chips).

The 25° nozzle (GREEN): This is a flushing nozzle. This pattern is best suited for flushing dirt, mud, and grime. Uses: Wet sweeping leaves from walks, curbs and driveways, cleaning stable floors, washing swimming pool bottoms, degreasing engines.

The 40° nozzle (WHITE): This is a wash nozzle. This wide spray pattern disperses the water pressure over a large area and is recommended for moderate washing. Uses: Washing down aluminum siding, cleaning windows, washing vehicles, spraying sidewalks, driveways and patios.

The 65° nozzle (BRASS 1/4" NPT): This is a low pressure detergent application nozzle. This broad spray pattern distributes solution over vast areas under low pressure. Uses: Detergent application, misting or rinsing. Factory Installed.

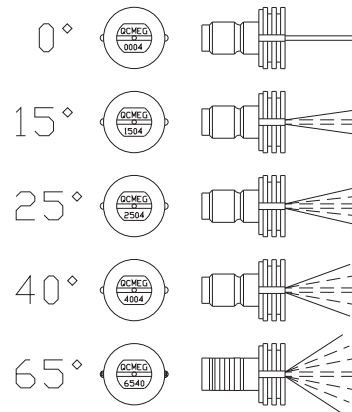

INSTALLATION & PREPARATION INSTRUCTIONS

Dual Lance Assembly with Adjustable Pressure

This unit features a Dual Lance Assembly with adjustable pressure which allows the user to select a high or low pressure “fan” spray. Simply rotate the adjustable grip on the dual lance to achieve the desired pressure selection.

1. Selection of high pressure can be achieved by turning the adjustable grip on the Dual Lance assembly counterclockwise as shown in the figure below.
2. Selection of low pressure detergent application can be achieved by turning the adjustable grip on the Dual Lance clockwise as shown in the figure below. Once the pressure is low enough, the detergent injector on the pressure washer will draw detergent into the system. A water/detergent mixture exits from both the spray nozzle and detergent nozzle.

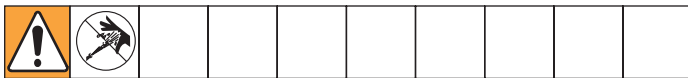
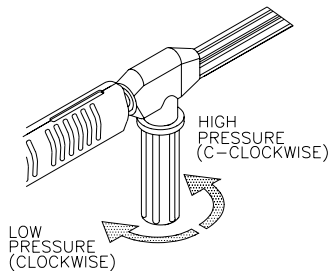

Dual Lance Connection

- Be certain the trigger gun is locked in the "OFF" position.
- Connect the dual lance assembly to the trigger gun assembly at this time. Be certain the connection is securely tightened.

Nozzle connection

Be certain the trigger gun is locked in the “OFF” position.

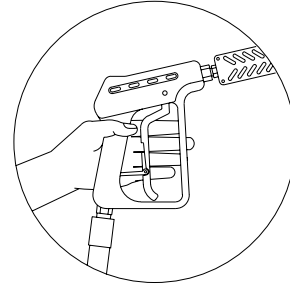

The quick connect nozzle assembly should be disconnected from the gun/wand assembly at this time by retracting the locking ring on the quick-connect fitting to remove the nozzle.

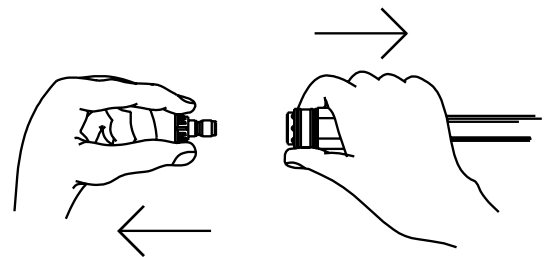

The detergent nozzle is factory installed.

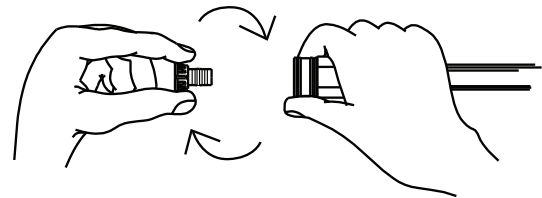

INSTALLATION & PREPARATION INSTRUCTIONS

Water Supply

Select a water supply hose which is a quality grade of garden hose measuring at least 3/4" ID and no longer than 50 feet.

Check the water inlet strainer to ensure it is clean and free of any obstructions. Periodic cleaning of the water strainer will help prevent pump problems.

NOTICE

As a strainer becomes obstructed, it restricts proper flow of water to the pump. This can result in cavitations which will cause premature failure of pump packings.

1. Unscrew the strainer cap from the unit.
2. Remove strainer screen, clean or replace if necessary.

Connect the hoses.

1. Connect one end of the water supply hose to the water inlet of the unit.
2. Connect the other end of the hose to your pressurized water supply.

Note: When connecting the water inlet to the water supply mains, local regulations of your water company must be observed. In some areas, the unit must not be connected directly to the public drinking water supply. This is to ensure there is no feedback of detergents into the water supply. (Direct connection is permitted if the backflow preventer is installed. Check with local authorities for approval.)

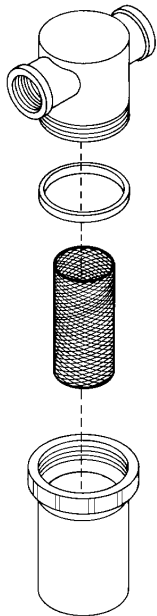

Note: If the mineral content of the water in your area is extremely high, the use of a water softener is recommended to prevent the possibility of excessive scale buildup inside the heat exchanger coil.

Follow the incoming water requirements listed below:

1. Water pressure must be a minimum of 20 pounds per square inch (PSI) and a maximum of 125 PSI. (A typical outdoor faucet will generally supply this PSI if turned completely "ON".)
2. Incoming GPM must be approximately one gallon more than the outgoing GPM stated on the pressure washer nameplate. (You can check GPM by timing how long it takes to fill a 5 gallon container.)

NOTICE

Incoming water temperature must not exceed 125°F. Excessive pump damage may result if the water temperature exceeds this acceptable level.

NOTICE

Damage to the equipment could occur. Never allow the unit to operate without the incoming water line attached and the water supply completely turned on.

INSTALLATION & PREPARATION INSTRUCTIONS

Unloader Adjustable

The unloader valve on your machine is equipped with an adjustment knob to adjust the pressure. Should less pressure be required, simply turn the adjustment knob counterclockwise. To set back to maximum, turn adjustment knob completely clockwise. Do not over-tighten.



NOTICE
Do not overtighten the unloader. Breakage could result in immediate loss of water pressure and costly repairs.

Thermal Relief Valve

To ensure the water temperature does not exceed acceptable levels, never allow the pressure washer to operate in the bypass mode (with the unit running and the trigger gun closed) for more than three minutes.

A “thermal relief valve” has been added to this unit to protect the pump. It may begin to open and release water if the water temperature in the pump has exceeded 140°F. This will allow fresh, cool water to enter the system.

Pre-Start Inspection Procedures

Before starting the unit, perform the following procedures:

1. Check the oil level in the pump and engine.
2. Inspect the water inlet strainer. Clean or replace if necessary. See “Water Supply” pg. 9.
3. Check all hose connections to ensure they are securely tightened. See “Water Supply” pg. 9.

<p>Inspect for system fuel leaks. If a fuel leak is found, do not start unit. See “Fire & Ventilation Precautions” pg. 4. Be sure that all damaged parts are replaced and that the mechanical problems are corrected prior to operation of the unit. If you require service, contact Graco Customer Service.</p>									

<p>Inspect high pressure hoses for kinking, cuts and leaks. If a cut or leak is found, do not use hose. Replace hose before starting unit. See “Miscellaneous Safety Precautions” pg. 5. Be sure that all damaged parts are replaced and that the mechanical problems are corrected prior to operation of the unit. If you require service, contact Graco Customer Service.</p>									

OPERATING INSTRUCTIONS

Priming the Pump

It is essential to prime the pump and flush the unit each time the water supply has been disconnected from the unit OR whenever the unit has set for any period of time. This unit has a steel coil which, after setting, will cause the water remaining in the coil from the previous usage to turn brown or black. This contaminated water must be flushed from the system before start-up. This procedure should be performed without the high pressure hose, gun and dual lance assembly installed.

Direct Feed:

1. Turn on the water supply.
2. Low pressure water will begin flowing from the water outlet. This allows the unit to prime and purge any air from the system. The unit is primed when water flow is uninterrupted by air.
3. Once the unit is primed, turn off the water supply and connect the high pressure discharge hose to the water outlet of the unit. (Note: The trigger gun and dual lance assembly should already be connected to the high pressure discharge hose at this time.)
4. Turn on the water supply.

NOTICE

Be certain the nozzle is not connected to the unit while priming the pump. Priming allows mineral deposits to be released from the system which would obstruct or damage the nozzle assembly resulting in costly repairs.

OPERATING INSTRUCTIONS

Start-up/Cold Water Operation



Refer to the "Safety Precautions" pgs. 3-5 before starting the unit.

Locate the Safety Decals on your unit and heed their warnings.

Never place hand or fingers in front of nozzle or look directly into the nozzle. High pressure water creates a risk of severe injury.

1. Ensure the burner switch is in the "OFF" position.
2. Pointing the trigger gun in a safe direction, unlock the trigger gun and squeeze the trigger. Hold the trigger gun open while starting the engine according to the manufacture's instructions in the engine manual accompanying this unit.
3. Once the engine has started, ensure the engine throttle is adjusted to full RPM and perform the following procedures with the trigger gun open:

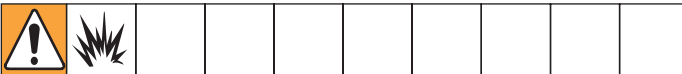

Inspect for system water leaks, oil leaks and fuel leaks. If a fuel leak is found, **TURN UNIT OFF IMMEDIATELY!** See "Fire & Ventilation Precautions", pg. 4. Be sure that all damaged parts are replaced and that the mechanical problems are corrected prior to operation of the unit. If you require service, contact Customer Service.



Inspect high pressure hoses for kinking, cuts and leaks. If a cut or leak is found, **DO NOT TOUCH HOSE AT LEAK!!! TURN UNIT OFF IMMEDIATELY!** Replace hose before starting the unit. See "Spray Precautions", pg. 3-4. Be sure that all damaged parts are replaced and that the mechanical problems are corrected prior to operation of the unit. If you require service, contact Customer Service.

4. At this point, the unit is operating as a cold water pressure washer. Trigger the gun several times and try adjusting the water pressure.

Note: Be certain to lock the trigger gun in the "OFF" position whenever changing the quick connect nozzles.

5. Your pressure washer can deliver high pressure spray and a variety of spray patterns using cold water. If you wish to use the Hot Water application or Cleaning with Detergents, see page 13-14 for the correct procedures.

NOTICE

Do not allow unit to operate in bypass mode (with trigger closed) for more than three minutes without triggering the gun. Failure to follow this simple rule can cause premature failure of pump packing seals, resulting in costly pump repair.

NOTICE

Do not allow spray pattern to remain on a fixed area for an extended period of time. Possible damage may occur to the area.

OPERATING INSTRUCTIONS

Start-up/Hot Water Operation



Refer to the “Safety Precautions” pgs. 3-5 before starting the unit.

Locate the Safety Decals on your unit and heed their warnings.

Never look directly into the nozzle. High pressure water creates a risk of severe injury.

1. Follow the steps outlined for “Start-up/Cold Water Operation”.
2. Move the Burner Switch to the ON position. On initial start-up, water will begin turning hot in approximately 20 seconds and will reach maximum temperature in approximately 2-1/2 minutes, provided the trigger remains squeezed. The burner will stop firing when the trigger is released.

Note: While spraying, it is normal for the burner to fire intermittently. The high-limit switch will cause combustion to cease when the temperature of the discharged water exceeds the maximum temperature setting of the switch. Combustion will begin again when the temperature drops below the minimum setting.



The water temperature could become very hot during hot water operation. Be cautious when adjusting pressure or controlling the trigger gun/dual lance assembly to avoid the possibility of burns.

NOTICE

Do not allow spray pattern to remain on a fixed area for an extended period of time. Possible damage may occur to the area.

OPERATING INSTRUCTIONS

Cleaning with Detergents



Refer to “Detergent Cleaning Precautions” pg. 4 before working with detergents. Be certain to wear protective safety attire.

Prepare detergent solution according to label directions. Never pump acids, alkaline, abrasive fluids or solvents through the unit.

NOTICE

This feature is designed for use with mild detergents only. Since the cleaning solution travels through the heat exchanger coil, Do Not use corrosives as they will cause extensive damage as well as pose a considerable safety hazard.

- Some units are equipped with adjustable detergent knobs. Locate the clear vinyl hose which leads to the pump head.
 - If your injector is equipped with an adjustment knob on the pump head, you may adjust the amount of detergent desired by turning the knob completely counterclockwise to set at the maximum siphon rate.
 - If your injector is not equipped with an adjustment knob, the detergent ratio is preset and cannot be adjusted.
1. Fully immerse the detergent strainer end of the clear vinyl hose into the detergent solution to allow detergent to siphon.
 2. Adjust the grip on the dual lance assembly. Turn the knob completely clockwise for low pressure detergent operation.

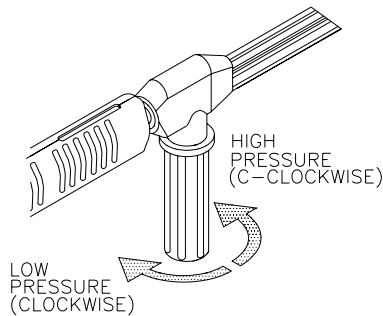

Note: This injection system is designed to apply detergents under low pressure only. It will not allow detergent solutions to be introduced into the system unless the dual lance assembly is set in the low pressure detergent mode.

3. To apply solution; unlock the trigger gun and squeeze the trigger. In a few moments a detergent/water mixture will exit the nozzle. Start spraying the lower portion of the surface being cleaned and move up, using long overlapping strokes. Applying from the bottom up helps avoid streaking. Allow to soak briefly. Do not allow detergent solution to dry on the surface. (Avoid working on hot surfaces or in direct sunlight to minimize the chances of the detergent drying, which may result in damaging painted surfaces.) Be certain to rinse a small section at a time.
4. To rinse; lock the trigger gun in the “OFF” position, rotate the adjustable grip on the dual lance counterclockwise for high pressure. Unlock the trigger gun and spray. It will take about 30 seconds to purge all detergent from the line. For best rinsing results, start at the top and work down.
5. Siphon a gallon of water through the low pressure detergent injection system after each use. This prevents the possibility of corrosion or detergent residue causing mechanical problems during the next use.

Shutdown

1. Move the burner switch to the “OFF” position.



2. Squeeze the trigger and discharge the water for a period of three minutes to cool the heat exchanger and high pressure hose. (Insufficient cool down period of the high pressure hose will cause excessive wear and eventually rupturing of the hose.)
3. Do Not close the choke to stop the engine. Backfire or engine damage may occur.



4. Move the engine On/Off Switch to the “OFF” position.
5. Close the engine fuel shut-off valve.
6. Turn off the water supply and pointing the gun in a safe direction, trigger the gun momentarily to relieve trapped pressure.
7. Disconnect, drain, and store hoses. Store unit in a non-freezing environment.

STORAGE & MAINTENANCE INSTRUCTIONS

Engine

The engine instructions that accompany your unit detail specific procedures for maintenance of the engine. Following the engine manufacturer's recommendations will extend engine work life.

Pump

The pump oil must be changed after the first 50 hours of operation. Once the initial oil change has been completed, it is recommended the oil be changed every 3 months or 250 hour intervals. If oil appears dirty or milky, changes may be required at a greater frequency. Add pump oil and fill only to the center of the sight glass (Refer to the parts listing for the correct pump oil). Do not overfill.

Nozzles

Water flow through the spray nozzle will erode the orifice, making it larger, resulting in a pressure loss. Nozzles should be replaced whenever pressure is less than 85% of the maximum. The frequency of replacement will depend upon such variables as mineral content in the water and number of hours the nozzle is used.

Couplers

There are o-ring seals inside the couplers which will deteriorate. To replace, simply install a replacement o-ring to correct the leak. (Additional o-rings can be purchased from your dealer.)

Fuel Water Separator

The fuel filter has a built in water separator. Occasionally the water has to be drained from the separator. Follow the procedures listed below:

- Check the collection bowl daily
- Ensure the unit is off and place an oil catch basin under the fuel cartridge.
- Loosen the drain plug to allow the fuel/water contaminants to flow into the catch basin.

- Retighten the drain plug when completed.
- Dispose of drainage according to environmental regulations in your area.

Burner Air Adjustment

The air shutter has been factory preset for proper operation between sea level and 2000 feet elevation at standard conditions (60°F ambient water and air temperatures). To assure maximum combustion efficiency at colder temperatures and higher altitudes, it will be necessary to adjust the air supply to the combustion chamber. A smoke spot test is recommended during any air shutter adjustment. This will aid in maximizing the burner efficiency and avoid inefficient operation and excessive sooting of the combustion chamber.

1. The machine must be running and the burner ON.
2. Take a smoke spot test to determine if more or less air is required for proper combustion.
 - If the test is greater than #3 smoke, turn the shutter arm counterclockwise to increase the air flow into the combustion chamber.
 - If the test is yellowish in color, turn the shutter arm clockwise to decrease the air flow into the combustion chamber.
3. Hold onto the air shutter adjusting arm and loosen the locking nut. Move the shutter in 1/8" increments and retighten the locking nut after each 1/8" movement.
4. Trigger the gun on the off slowly to make sure there is proper ignition. Slight or not puffing on the ignition, and a smoke spot test of less than #3 smoke is good.
5. Repeat steps 2 and 3 until step 4 is attained.

Leaks

Promptly eliminate any leaks found in the pumping system by removing suspect parts, applying thread sealant to the threads and reinstalling.



NOTICE

If using PTFE tape, be certain no tape gets inside any plumbing to prevent the possibility of a plugged spray nozzle.

STORAGE & MAINTENANCE INSTRUCTIONS

Winterizing

For storage and transportation purposes in subfreezing ambient temperatures, it will be necessary to winterize this unit. This unit must be protected to the lowest incurred temperature for the following reasons:

									
---	---	---	--	--	--	--	--	--	--

- If any part of the pumping system becomes frozen; excessive pressure may build up in the unit which could cause the unit to burst resulting in possible serious injury to the operator or bystanders.
- The pumping system in this unit may be permanently damaged if frozen. Freeze damage is not covered by warranty.

If you must store your unit in an area where the temperature may fall below 32°F, you can protect your unit by following the procedure outlined below.

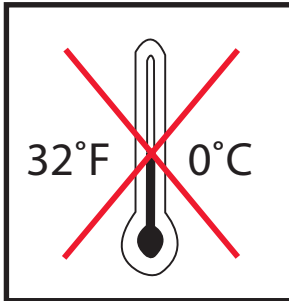

NOTICE

Do not store/operate unit in a freezing environment. Damage to washer could occur.

Gather the following items:

- Two 5 gallon containers.
- One gallon of antifreeze. (Graco® recommends an environmentally safe antifreeze.)
- Water supply.
- Three foot hose, 1/2-3/4 I.D. with a 3/4 inch male garden hose fitting.

Procedure:

1. To start winterizing, unit must be run and primed according to the “Start-up Procedures” listed on page 12.
2. After running and priming, shut off the unit and water supply.
3. Relieve system pressure by pointing the trigger gun in a safe direction and squeezing the trigger until water flow ceases to exit the Dual Lance Assembly.
4. Lock the trigger gun in an OFF position and remove the nozzle.

5. In one 5 gallon container, mix the antifreeze and water according to manufacturer’s recommendations for the temperature to which you are winterizing.

Note: Proper winterizing is based on the recommended manufacturer’s instructions listed on the “Protection Chart” shown on the back label of most antifreeze containers.

6. Remove the water supply hose from the unit and attach the 3 foot hose securely to the inlet connection. Submerge the other end into the antifreeze solution.
7. Shut off the detergent injector if applicable.
8. Holding the 3 foot hose in an upright position, completely fill the hose with water. Then plug the hose outlet with your thumb or finger. Place the plugged end into the 5 gallon container of water.
9. Start the unit. Trigger the gun several times until all the air is worked out of the system (unit is primed). It may be necessary to adjust the engine RPM down to an idle to aid in priming.
10. With the trigger gun held open, siphon enough water out of the 5 gallon container until there is just enough water left to mix with the antifreeze.
11. Point the trigger gun into the empty container.
12. Trigger the gun until the antifreeze begins to exit the trigger gun. Release the trigger for 3 seconds, then trigger the gun for 3 seconds. Continue cycling the trigger gun several times until all the antifreeze mixture is siphoned from the container.
13. Detach the 3 foot hose from the unit and drain any excess antifreeze back into the 5 gallon container.
14. Disconnect the hose and trigger gun from the unit and drain any excess antifreeze back into the 5 gallon container.
15. Store the hose, trigger gun and dual lance assembly with the unit in a safe area.
16. Store antifreeze solution for next use or dispose of according to state EPA laws.

Optional Procedure:

1. Shut the unit and water supply off.
2. Relieve system pressure by pointing the trigger gun in a safe direction and squeezing the trigger until water flow ceases to exit the nozzle.
3. Disconnect and drain the hose, gun and dual lance
4. Remove the hose from the inlet side of the heat exchanger coil.
5. Start the unit and allow it to run until all the water exits the unit. Once the water has stopped flowing from the unit, turn the unit off.

NOTICE

When using this procedure, caution should be used as ice chips can form from drops of water which could cause the unit to burst if starting before completely thawed.

Troubleshooting

Problem	Cause	Solution
Engine will not start.	Various engine problems.	Refer to the engine manual accompanying your unit.
	Unit components are frozen.	Allow to thaw. If any part of the unit becomes frozen; excessive pressure may build up in the unit which could cause the unit to burst resulting in possible serious injury to the operator or bystanders.
No discharge at nozzle when trigger mechanism is squeezed.	Inadequate water supply.	Ensure hose is 3/4" (19.05mm) diameter and incoming water supply is turned on.
Low or fluctuating pressure.	Kink in water inlet hose.	Remove kink.
	Kink in high pressure discharge hose.	Replace hose.
	Water inlet screen obstructed.	Remove screen, clean or replace.
	Pump sucking air. (Prime eliminated)	Tighten all water intake connections. Eliminate leaks in intake line.
	Adjustable grip on dual lance is not in high pressure mode.	Insert a high pressure nozzle.
	Obstructed or worn spray nozzle.	Remove, clean or replace.
	Damaged or obstructed valve assembly on pump.	Remove, inspect, clean or replace.
	Pump packing worn.	Replace packings.
	Bypass valve not operating correctly.	Repair or replace.
Water is leaking from the "Heat Dump Valve".	Water temperature is too high.	Do not allow the unit to operate in the bypass mode (with trigger gun closed) for more than 3 minutes.
	Defective valve.	Replace.
Oil appears milky or foamy.	Water in oil.	Change pump oil. Fill to proper level.
Oil leaking from unit.	Do Not Use.	Contact Customer Service.
Detergent will not siphon into Low Pressure Detergent mode.	Detergent strainer is not completely submerged in detergent solution.	Check, submerge if necessary.
	Detergent strainer is obstructed.	Inspect, clean or replace.
	Detergent hose cut, obstructed.	Inspect, clean or replace.
	Detergent adjusting knob on pump turned to closed position. (If applicable.)	Open adjusting knob. Refer to "Cleaning with Detergents" pg.15.
	Adjustable grip on dual lance is not in low pressure mode.	Insert 6540° (BLACK) nozzle.
	Nozzle assembly is plugged.	Clean or replace.
	Too many high pressure hose extensions attached to the water outlet.	Use one extension maximum.
	Ball and Spring in Venturi stuck.	Remove, clean or replace.
Water flows back into detergent container.	Ball and Spring in Venturi reversed, missing or corroded.	Remove, clean or replace.
Water flows from the nozzle when the trigger gun is locked in the "OFF" position.	Gun is malfunctioning.	Repair or replace.

Troubleshooting

Problem	Cause	Solution
Water is leaking under heat exchanger coil.	Coil drain plug is not installed.	Install.
	Safety relief device is relieving caused by an unloader or pressure switch problem.	Detect and correct unloader or pressure switch problem. Replace safety relief device. Never run unit without safety relief device. Doing so can cause an explosion.
Burner will not ignite.	Burner switch is not turned on.	Check switch position.
	Out of fuel.	Refuel.
	Trigger gun is closed.	Open trigger gun for pressure.
	EMF Drive belt loose or broken.	Adjust or replace as necessary.
	Flexible coupler broken.	Replace.
	Dirty or clogged fuel filter/water sep.	Drain or replace as necessary.
	Fuel pump sucking air.	Tighten all fuel intake connections. Eliminate leaks in intake line.
	Fuel pump inoperative.	Check pressure, replace if needed.
	Fuel pickup screen is obstructed.	Consult Service.
	Dirty or clogged fuel nozzle.	Replace fuel nozzle.
	Ignition module.	Consult Service.
	Ignition electrodes damaged or worn.	With unit running and trigger gun closed, look through burner sight glass to ensure there is sparking across electrodes.
	No voltage.	Consult Service.
	Pressure switch override.	Pressure should be over 250 PSI/18 Bar to allow burner to come on.
	Highlimit switch override.	Allow unit to cool down before reigniting.
	Improper burner air adjustment.	Adjust as shown on page 16.
Fuel solenoid valve failure.	Replace.	
Burner runs erratically.	Water in the fuel oil.	Drain fuel filter/water separator, drain fuel tank and replace with clean fuel.
	Dirty fuel filter/water separator.	Replace element.
	Dirty fuel nozzle.	Replace.
	Improper air adjustment setting.	Adjust as shown on page 16.
	Fuel pickup screen is obstructed.	Consult Service.
	Fuel pump malfunctioning.	Replace.
Burner runs, but will not heat	Poor or improper fuel supply.	Check fuel to ensure it is correct. Drain tank and filter if necessary and refill with proper fuel.
	Low fuel pump pressure.	Check fuel pump pressure, replace if needed.
	Dirty fuel nozzle.	Replace.
	Improper air adjustment setting.	Adjust as shown on page 16.
	Fuel pickup screen is obstructed.	Consult Service.
	Scale build up in heat exchanger coil.	Consult Service.
Burner discharges white smoke.	Low on fuel	Refuel. If white smoke persists, consult Service.
	Excessive air supply.	Adjust as shown on page 16.
Burner discharges black smoke	Insufficient air supply.	Adjust as shown on page 16.

PUMP SERVICE: 3540 GHW MODEL PRESSURE WASHERS

Repair kits are available. See the Parts List, page 32.
For the best results, use all parts in kits.



Follow Shutdown Procedure page 14, to relieve system pressure.

- Drain and refill pump after 25 hours of operation.

Valves

For a set of six valves, order Valve Assembly Kit 24E976.

1. Remove hex plug from the manifold using a 24mm wrench.
2. Examine o-ring located under hex plug. Replace if cut or distorted.
3. Remove valve assembly from cavity. The assembly may come apart!
4. Install new valve, o-ring and hex plug. Torque to 40 ft-lb (54.2 Nm)

Note: Retorque the plug after 5 hours operation.

Pumping Section

1. Remove capscrews and lock washers from manifold.
2. Carefully separate manifold from the crankcase. You may have to lightly tap the manifold with a soft mallet to loosen it.

NOTICE

To avoid damage to plunger or seals, keep manifold properly aligned with the ceramic plungers when you remove it.

3. Carefully examine each plunger for any scoring or cracking. Replace as necessary.

Servicing Plungers

1. Loosen plunger retaining nut five or six turns using a 16mm wrench. Push plunger toward the crankcase to separate plunger and retaining screw.
2. Remove nut from plunger and examine and clean o-ring.
3. Remove piston sleeve, backup ring, and copper washer from plunger shaft. Clean parts as necessary.
4. Inspect plunger shaft for oil leaks from crankcase. If leaking is obvious, replace oil seals. Otherwise, DO NOT remove these seals because they cannot be reused. Oil Seal Kits are available for replacing seals.
5. Lightly grease the flinger (and oil seal if it is being

replaced) on plunger shaft. Then install copper washer, backup ring, piston and washer.

6. Lightly grease the retaining screw and outer end of the plunger and install nut through plunger. Torque to 7.4 ft-lb (10.2 Nm).

Note: If replacing packings, see Servicing V-Packings.

7. Lubricate outside of each plunger. Slide the manifold on the crankcase, being careful not to damage seals.
8. Install capscrews and washers finger tight. Torque screws to 18 ft-lb (24.2 Nm) following the tightening pattern in the following figure.

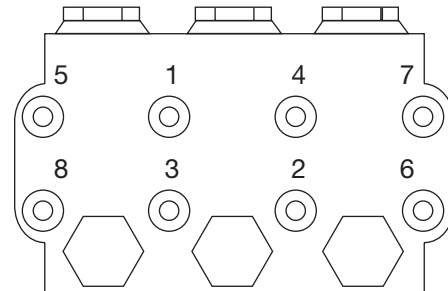

NOTICE

Uneven tightening could cause the manifold to bind or jam.

Servicing V-Packings

1. Remove manifold as described in Pumping Section.
2. Carefully pull packing retainer from manifold. Examine o-ring. Replace o-ring if cut or damaged.
3. Remove V-Packing and support ring. Remove low pressure seal from retainer.
4. Inspect all parts and replace as necessary.
5. Thoroughly clean packing cavities and inspect for damage.
6. Lightly grease packing cavities. Replace packings in the following order:

- support ring
- v-packing
- packing retainer
- low pressure seal in retainer
- o-ring in retainer groove

NOTICE

Packings must be installed in the proper order and facing the correct direction. Improperly installed parts will cause the pump to malfunction.

7. Reassemble manifold following procedure described in Servicing Plungers.

Pressure Washer - Parts

262298- Model 3540 GHW

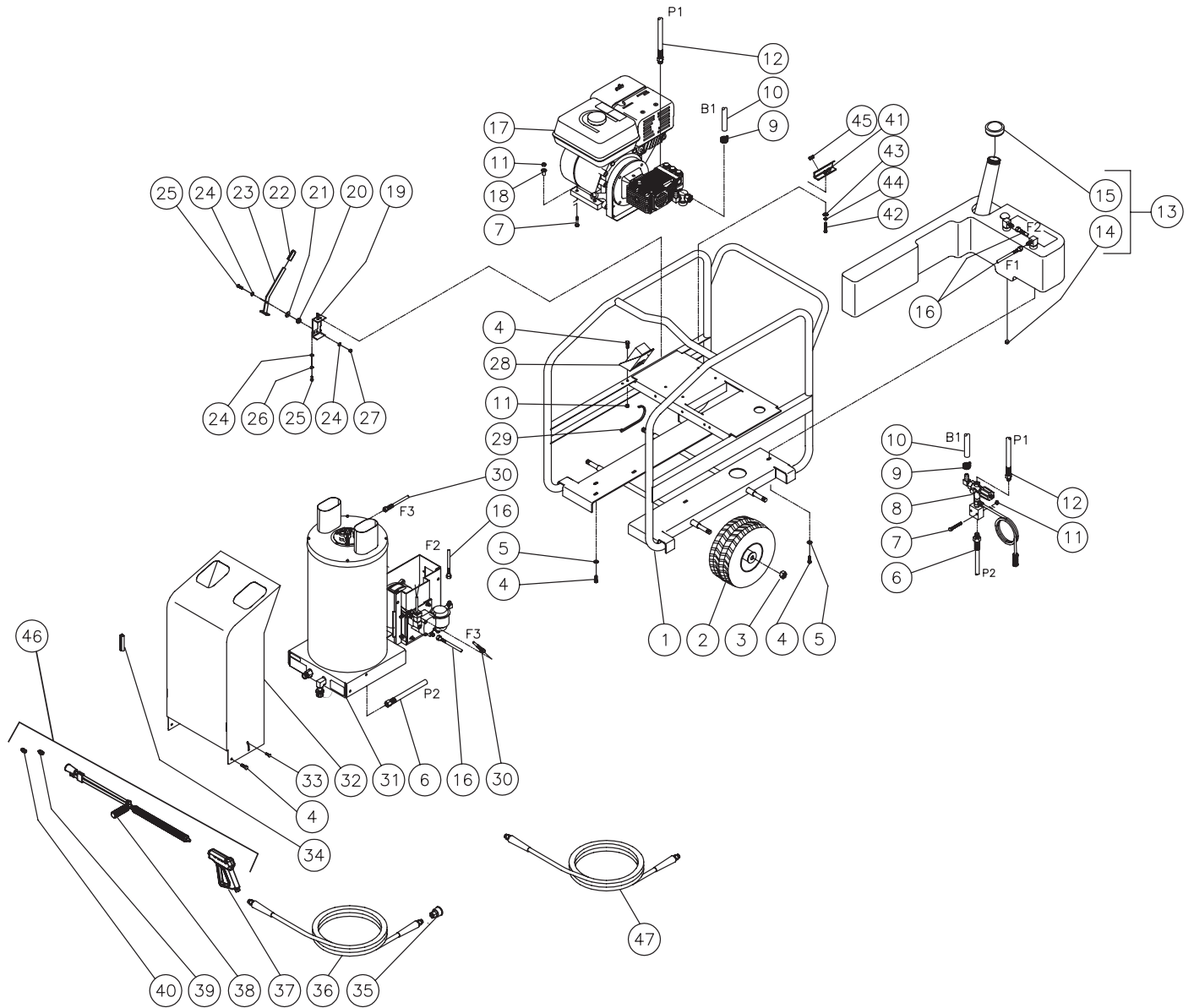

Pressure Washer - Parts

262298 - Model 3540 GHW

262298 - Model 3540 GHW			DESCRIPTION	PART #	QTY	
	DESCRIPTION	PART #	QTY	26 Lockwasher	100214	2
1	Frame Assembly	16E636	1	27 Locknut	111040	1
2	Wheel	16E474	4	28 Bracket/Electric Box Assembly (See Exploded Drawing)	N/A Sep.	1
3	Jam Nut	119554	4	29 Wire Tie	16E620	4
4	Bolt	16E599	12	30 Fuel Hose Assembly	16E555	1
5	Flatwasher	107194	8	31 Heat Exchanger/EMF Assembly (See Exploded Drawing)	N/A Sep.	1
6	High Pressure Hose Assembly	16E558	1	32 Hood Assembly	16E642	1
7	Bolt	16E601	6	33 Hand Knob	16E638	1
8	Unloader/ Manifold Assembly (See Exploded Drawing)	N/A Sep.	1	34 Trim Lock *(One Foot Required)	16E621	1
9	Fuel Clamp	16E502	2	35 Screw Connect	16E561	1
10	Hose	16J762	2	36 Hose Assembly	16E556	1
11	Hex Nut	16E611	8	37 Gun Assembly	16E559	1
12	High Pressure Hose Assembly	16E557	1	38 Dual Lance Assembly	16E560	1
13	Fuel Tank Assembly (Includes 14, 15)	16E645	1	39 Nozzle, 0°	805539	1
14	Countersunk Hex Head Plug	16E587	1	- Nozzle, 15°	805540	1
15	Fuel Cap	16E551	1	- Nozzle, 25°	805541	1
16	Fuel Hose	16E554	2	- Nozzle, 40°	805542	1
17	Engine/Pump Assembly (See Exploded Drawing)	N/A Sep.	1	40 Nozzle- Detergent	805404	1
18	Shim	16E622	4	41 Bracket, Nozzle Holder	16E824	1
19	Bracket	16E574	1	42 Bolt	111302	2
20	Grommet	16E625	1	43 Washer	107194	2
21	Washer	16E604	1	44 Lock Washer	100214	2
22	Handle Grip	16E640	1	45 Grommet	16E489	4
23	Brake Handle Assembly	16E573	1	46 Gun and Lance Assembly Includes 37, 38, 40	24J774	
24	Washer	16E602	4	47 Hose, Extension 50' (For Added Length)	16M463	1
25	Screw	100521	3			

Engine/Pump Assembly - Parts

Item 17 (for use with Model 3540 GHW)

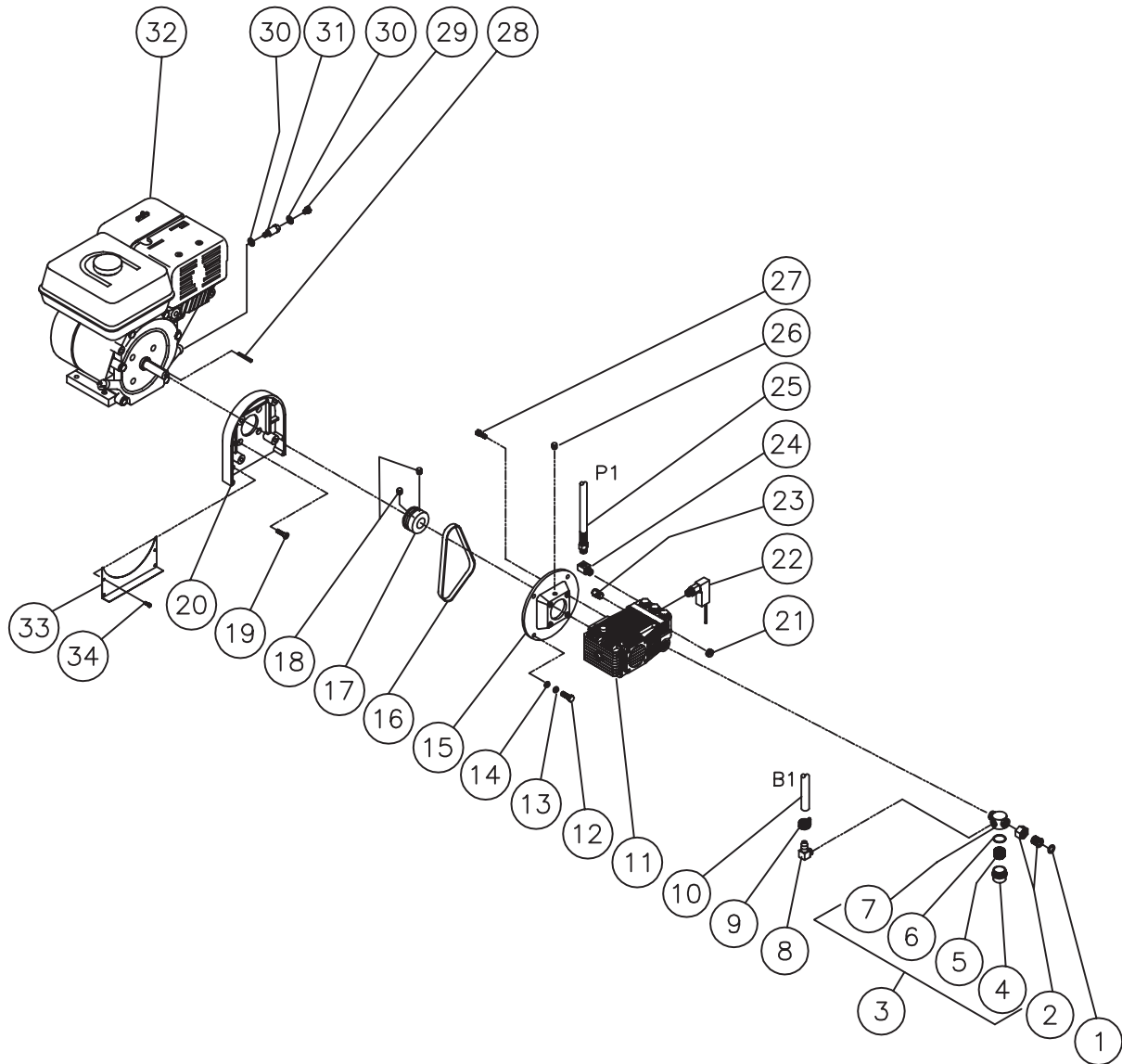

Engine/Pump Assembly - Parts

Item 17 (for use with Model 3540 GHW)

	DESCRIPTION	PART #	QTY	DESCRIPTION	PART #	QTY
1	Hose Gasket	16E592	1	19 Bolt	16E594	4
2	Hose Swivel	244746	1	20 Adaptor Plate	16E631	1
3	Strainer Complete (Includes 4-7)	16E566	1	21 Plug	16E583	1
4	Strainer Bowl	N/A	1	22 Pressure Switch	16E575	1
5	Screen	N/A	1	23 Heat Dump Valve	116461	1
6	Strainer O-ring	N/A	1	24 Elbow	16E577	1
7	Strainer Cap	N/A	1	25 High Pressure Hose	16E557	1
8	Elbow	16E579	1	26 Set Screw	16E597	1
9	Hose Clamp	16E502	1	27 Bolt	16E595	4
10	Hose	16J762	1	28 Key	16E634	1
11	High Pressure Pump	16E609	1	29 Oil Drain Plug	N/A	1
12	Bolt	16E593	4	30 Washer	16E605	2
13	Lockwasher	16E606	4	31 Oil Drain Port	16E589	1
14	Flatwasher	16E603	4	32 Engine	16E660	1
15	Flange/ Pump Adapter	16E632	1	33 Beltguard	16E571	1
16	Belt	16E550	1	34 Bolt	16E600	4
17	Sheave	16E549	1			
18	Set Screw	16E598	2			

Pump Assembly - Parts

16E609 (for use with Model 3540 GHW)

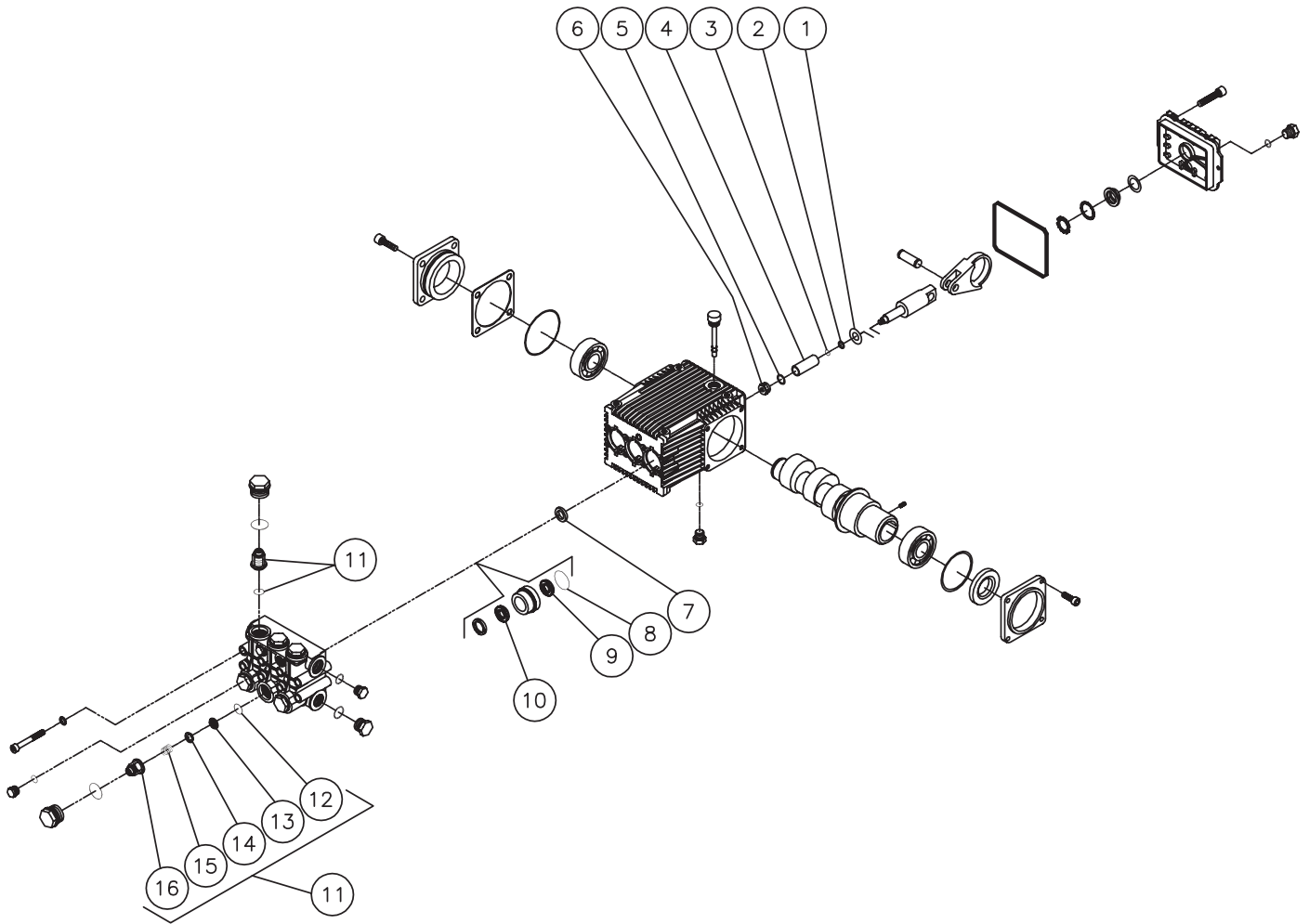

Pump Assembly - Parts

16E609 (for use with Model 3540 GHW)

DESCRIPTION	PART #	QTY
KIT, REPAIR, VALVES INCLUDES 12-16 (11)	24E976	6
KIT, REPAIR, OIL SEALS INCLUDES 7	24E978	3
KIT, REPAIR, PISTON INCLUDES 1-6	24E977	3
KIT, REPAIR, PACKINGS INCLUDES 8-10	24E979	3

Unloader/Manifold Assembly - Parts

Item 8 (for use with Model 3540 GHW)

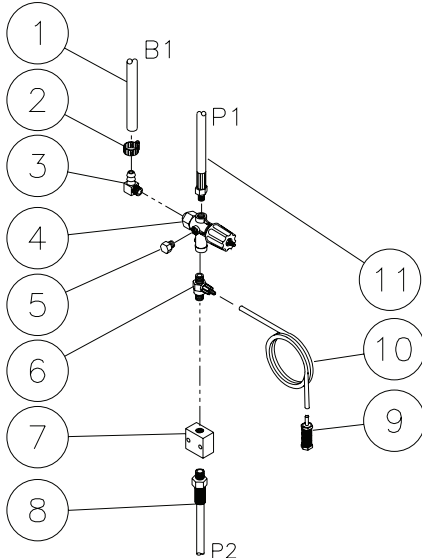

Unloader/Manifold Assembly - Parts

Item 8 (for use with Model 3540 GHW)

	DESCRIPTION	PART #	QTY
1	Hose	16J762	1
2	Hose Clamp	16E502	1
3	Elbow	16E579	1
4	Unloader Assembly	16E646	1
5	Plug	16E582	1
6	Detergent Injector	24E793	1
7	Manifold Block	16E637	1
8	High Pressure Hose Assembly	16E558	1
9	Detergent Strainer	16E562	1
10	Detergent Hose (Six Feet Required)	16E553	1
11	High Pressure Hose Assembly	16E557	1

Heat Exchanger/EMF Assembly - Parts

Item 31 (for use with Model 3540 GHW)

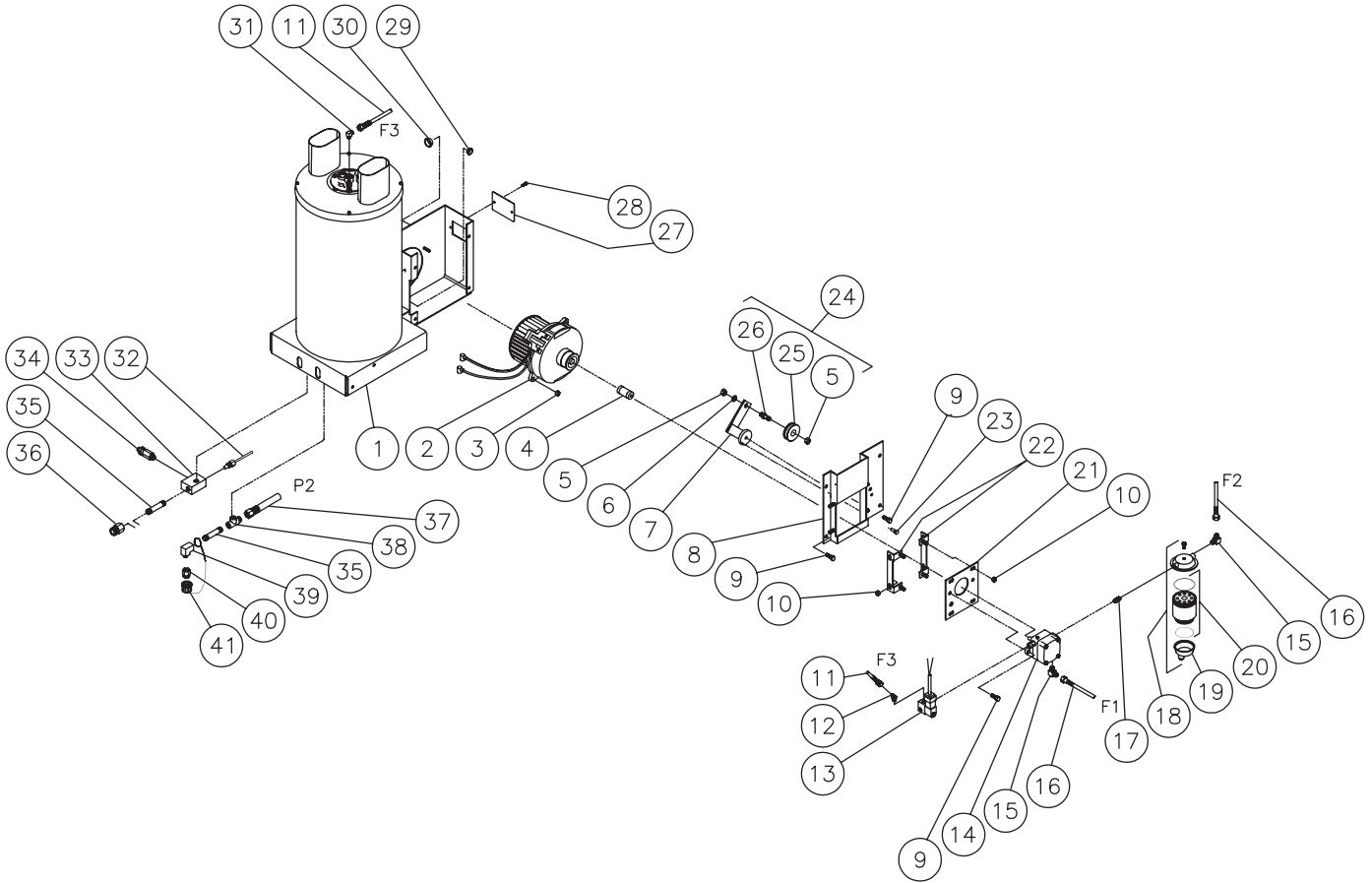

Heat Exchanger/EMF Assembly - Parts

Item 31 (for use with Model 3540 GHW)

	DESCRIPTION	PART #	QTY	DESCRIPTION	PART #	QTY
1	Boiler Assembly Complete	16E644	1	21 Plate	16E568	1
2	EMF Assembly	16E647	1	22 Bracket	16E567	2
3	Hex Nut	16E610	2	23 Pin	16E623	1
4	Fuel Pump Coupler	16E624	1	24 Tensioner Sheave Shaft		
5	Nut	N/A	2	Assembly (Inc. 5, 25, 26)	16E641	1
6	Flatwasher	107194	1	25 Sheave Assembly	N/A	1
7	Tensioner Base	16E548	1	26 Shaft	N/A	1
8	Fuel Pump Bracket	16E570	1	27 Access Panel	16E572	1
9	Bolt	16E599	7	28 Bolt	16E600	2
10	Hex Nut	16E611	8	29 Grommet	16E616	1
11	Fuel Hose Assembly	16E555	1	30 Grommet	16E617	1
12	Elbow	16E586	1	31 Elbow	16E585	1
13	Fuel Solenoid- 12 Volt	16E635	1	32 High Limit Switch	16E615	1
14	Fuel Pump	16E608	1	33 Outlet Connector Block	16E588	1
15	Elbow	16E581	2	34 Pressure Relief Valve	16E576	1
16	Fuel Hose	16E554	2	35 Nipple	16E591	2
17	Hex Nipple	16E590	1	36 Hex Reducer	16E580	1
18	Filter Fuel Water Seperator	16E564	1	37 High Pressure Hose Assembly	16E558	1
19	Fuel Water Seperator Replacement Bowl	16E565	1	38 Street Tee	16E578	1
20	Fuel Water Seperator Replacement Filter	16E563	1	39 Elbow	16E557	1
				40 Adapter	16E584	1
				41 Drain Plug Assembly	16E643	1

Bracket/Electrical Box Assembly - Parts

Item 28 (for use with Model 3540 GHW)

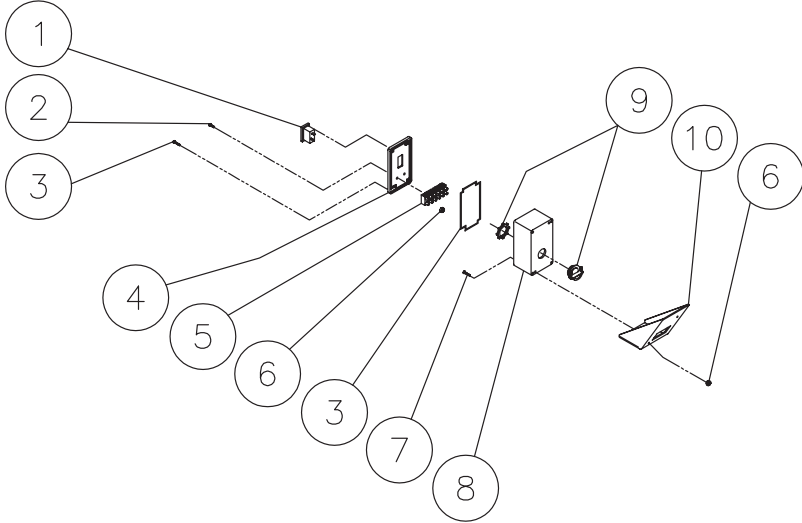

Bracket/Electrical Box Assembly - Parts

Item 28 (for use with Model 3540 GHW)

	DESCRIPTION	PART #	QTY
1	Switch/ Rocker	16E614	1
2	Bolt	16E596	2
3	Bolt and Gasket Kit	16E639	1
4	Electric Box Lid- Black	16E619	1
5	Terminal Strip	16E613	1
6	Hex Nut	16E607	4
7	Bolt	16E826	2
8	Electric Box- Black	16E618	1
9	Electrical Connector	16E612	1
10	Electric Box Bracket- Black	16E569	1

Decal Placement - Parts

262298 - Model 3540 GHW

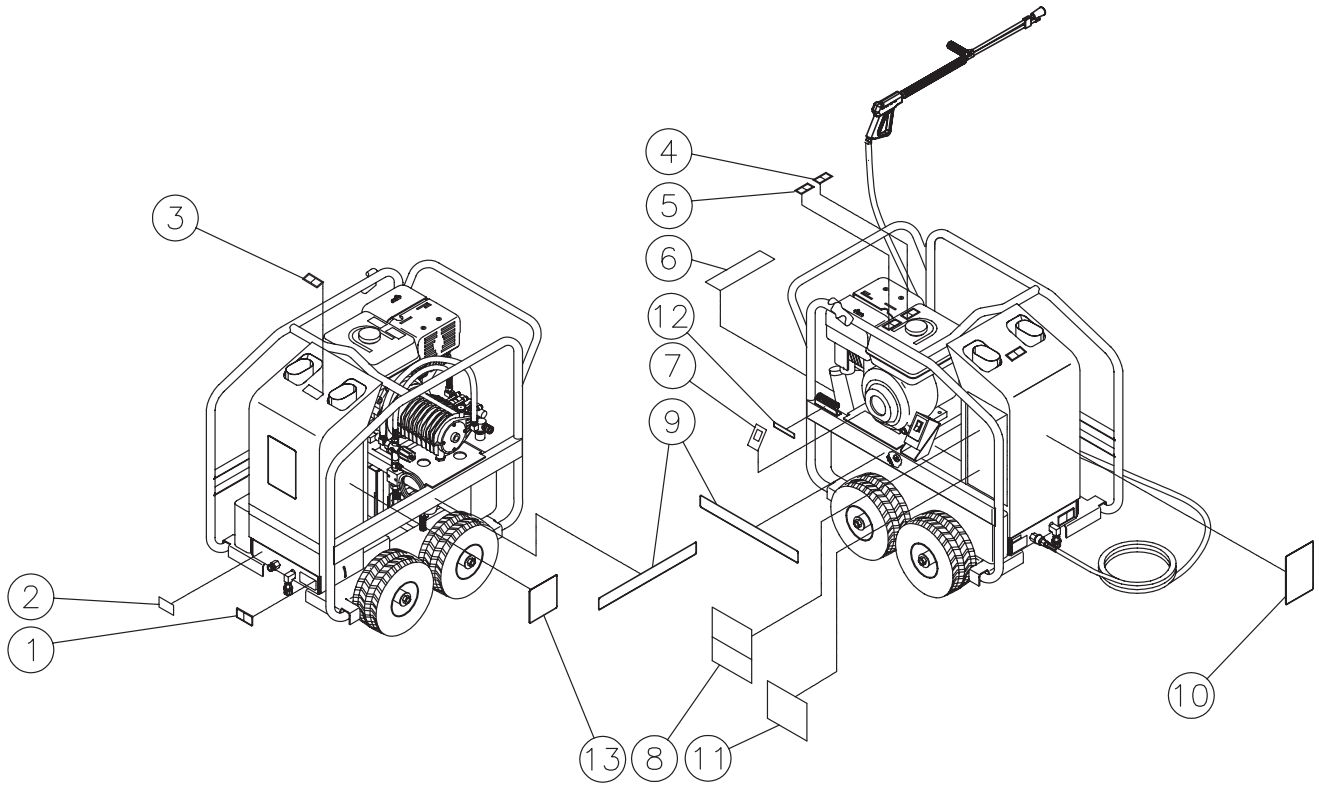

Decal Placement - Parts

262298 - Model 3540 GHW

	DESCRIPTION	PART #	QTY
1▲	Warning- Plumbing	N/A	1
2	Decal- Silver Sticker	N/A	1
3▲	Warning- Hot	N/A	1
4▲	Warning- Allow to Cool	N/A	1
5▲	Warning- Hot Surface	N/A	1
6▲	Warning- Risk of Fire	N/A	1
7	Label- Burner On/Off	N/A	1
8▲	Label- Warning/Caution	N/A	1
9	Label- G-Force Side	16E775	2
10	Label- G-Force 3540 GHW	16E228	1
11	Label- Operation	N/A	1
12	Label- Tip Holder	16E776	1
13	Label- Brand, Graco	16E773	1
14▲	Decal Set, Safety	16E947	1
	Includes 1, 3, 4, 5, 6, 7, 8, 11		

▲ Replacement warning decals available at no cost.

Technical Data

	Model 3540 GHW
Working pressure range	3325-3500 psi
Operating Pressure	3500 psi
Maximum Working Pressure	3500 psi
Engine Displacement	390 cc
Maximum delivery	3.3 gpm (12.51 l/mn)
High pressure hose	50' x 3/8" 4500 psi
Chemical Injector hose	1/4" x 6'
Weight	428 LB (195 kg)
Dimensions	
Length	43" (109 cm)
Width	30" (76 cm)
Height	41" (104 cm)
Pump inlet fitting	3/4" ghf
Storage temperature range	-30° – 125°F (-34° – 52°C)
Operating Temperature range	40° – 104°F (4.4° – 40°C)
Sound Pressure	93.6 dB(A)
Sound Power	108.7 dB(A)
Gasoline tank capacity	1.72 gal
Maximum input pressure	125 psi
Maximum operating temperature	250°F
Unit	(121°C)
Burner Fuel Type	No. 1 or No. 2 Fuel oil, Diesel or Kerosene
Burner Fuel Capacity (gal/liters)	5.5/2.1
Fuel Filter/Water Separator	Spin on (10 micron) filter/ E-Z Water Drain
Fuel Pressure (PSI/bar)	145/10
Fuel Nozzle	1.75 60° B Delavin
Fuel Consumption	2.1 GPH (Continuous)
EMF Ignition	Belt Driven (Patent #5,954,494)
EMF Control Voltage	12V DC
Heat Exchanger BTU	294,000
HE Efficiency	86% w/#2 Fuel Oil
HE Smoke Density	0-3 ASTM D2156
Fuel Solenoid	12V

Graco Standard Warranty

Graco warrants all equipment referenced in this document which is manufactured by Graco and bearing its name to be free from defects in material and workmanship on the date of sale to the original purchaser for use. With the exception of any special, extended, or limited warranty published by Graco, Graco will, for a period of twelve months from the date of sale, repair or replace any part of the equipment determined by Graco to be defective. This warranty applies only when the equipment is installed, operated and maintained in accordance with Graco's written recommendations.

This warranty does not cover, and Graco shall not be liable for general wear and tear, or any malfunction, damage or wear caused by faulty installation, misapplication, abrasion, corrosion, inadequate or improper maintenance, negligence, accident, tampering, or substitution of non-Graco component parts. Nor shall Graco be liable for malfunction, damage or wear caused by the incompatibility of Graco equipment with structures, accessories, equipment or materials not supplied by Graco, or the improper design, manufacture, installation, operation or maintenance of structures, accessories, equipment or materials not supplied by Graco.

This warranty is conditioned upon the prepaid return of the equipment claimed to be defective to an authorized Graco distributor for verification of the claimed defect. If the claimed defect is verified, Graco will repair or replace free of charge any defective parts. The equipment will be returned to the original purchaser transportation prepaid. If inspection of the equipment does not disclose any defect in material or workmanship, repairs will be made at a reasonable charge, which charges may include the costs of parts, labor, and transportation.

THIS WARRANTY IS EXCLUSIVE, AND IS IN LIEU OF ANY OTHER WARRANTIES, EXPRESS OR IMPLIED, INCLUDING BUT NOT LIMITED TO WARRANTY OF MERCHANTABILITY OR WARRANTY OF FITNESS FOR A PARTICULAR PURPOSE.

Graco's sole obligation and buyer's sole remedy for any breach of warranty shall be as set forth above. The buyer agrees that no other remedy (including, but not limited to, incidental or consequential damages for lost profits, lost sales, injury to person or property, or any other incidental or consequential loss) shall be available. Any action for breach of warranty must be brought within two (2) years of the date of sale.

GRACO MAKES NO WARRANTY, AND DISCLAIMS ALL IMPLIED WARRANTIES OF MERCHANTABILITY AND FITNESS FOR A PARTICULAR PURPOSE, IN CONNECTION WITH ACCESSORIES, EQUIPMENT, MATERIALS OR COMPONENTS SOLD BUT NOT MANUFACTURED BY GRACO. These items sold, but not manufactured by Graco (such as electric motors, switches, hose, etc.), are subject to the warranty, if any, of their manufacturer. Graco will provide purchaser with reasonable assistance in making any claim for breach of these warranties.

In no event will Graco be liable for indirect, incidental, special or consequential damages resulting from Graco supplying equipment hereunder, or the furnishing, performance, or use of any products or other goods sold hereto, whether due to a breach of contract, breach of warranty, the negligence of Graco, or otherwise.

For Graco Canada Customers

The Parties acknowledge that they have required that the present document, as well as all documents, notices and legal proceedings entered into, given or instituted pursuant hereto or relating directly or indirectly hereto, be drawn up in English. Les parties reconnaissent avoir convenu que la rédaction du présente document sera en Anglais, ainsi que tous documents, avis et procédures judiciaires exécutés, donnés ou intentés, à la suite de ou en rapport, directement ou indirectement, avec les procédures concernées.

Graco Information

TO PLACE AN ORDER, contact your Graco distributor or call 1-800-690-2894 to identify the nearest distributor.

All written and visual data contained in this document reflects the latest product information available at the time of publication.

Graco reserves the right to make changes at any time without notice.

For patent information, see www.graco.com/patents.

Original instructions. This manual contains English MM 3A0592

Graco Headquarters: Minneapolis

International Offices: Belgium, China, Japan, Korea

GRACO INC. AND SUBSIDIARIES • P.O. BOX 1441 • MINNEAPOLIS MN 55440-1441 • USA

Copyright 2010, Graco Inc. All Graco manufacturing locations are registered to ISO 9001

www.graco.com

Revised January 2013