

ThermoLazer™ Die Heat Retrofit Kit Model 24H620

3A1585B
EN

- For professional application of thermoplastic traffic marking compound materials (reflective beads applied simultaneously with screeding) -
- For outdoor use only (not to be operated in rain or damp conditions) -



IMPORTANT SAFETY INSTRUCTIONS

Read all warnings and instructions in manual 3A1319. Save these instructions.

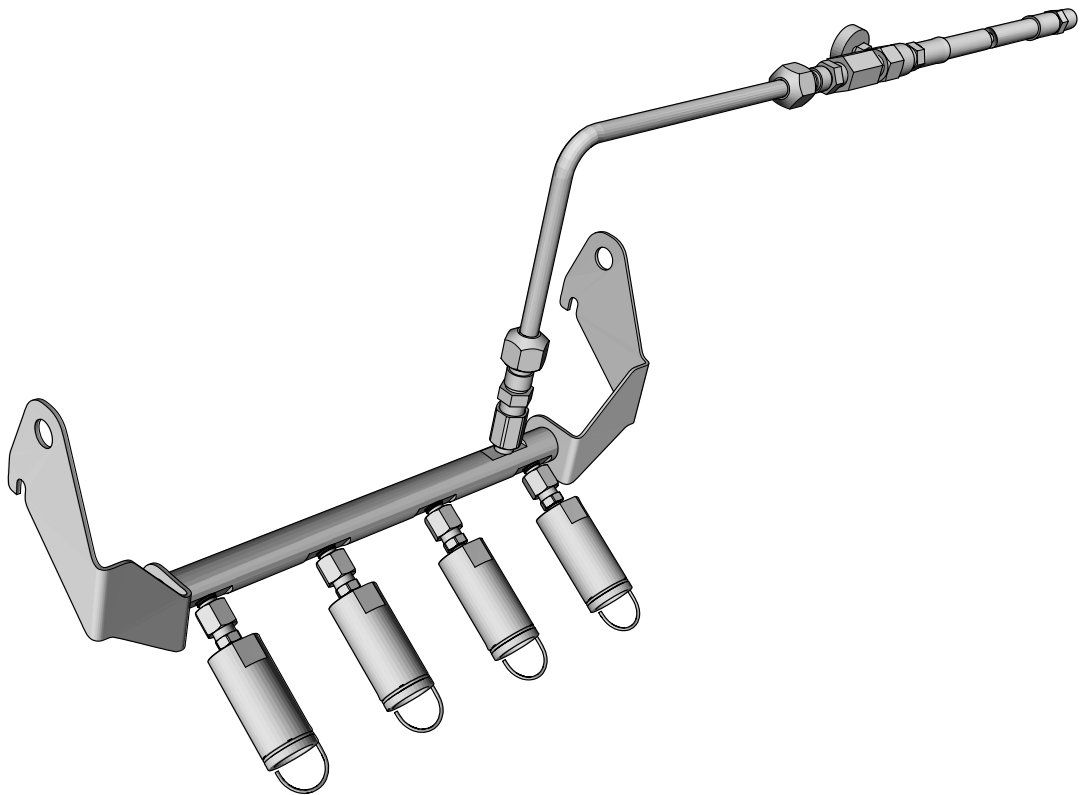

ti22971a

Installation



1. Disconnect propane source.

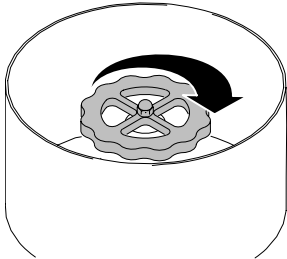

ti14128a

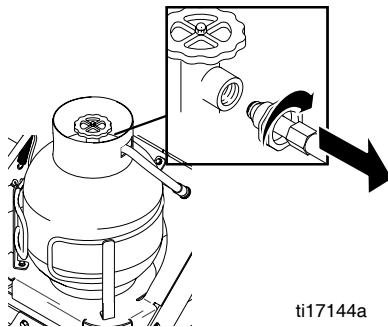

ti17144a

2. Close valve by torch regulator.

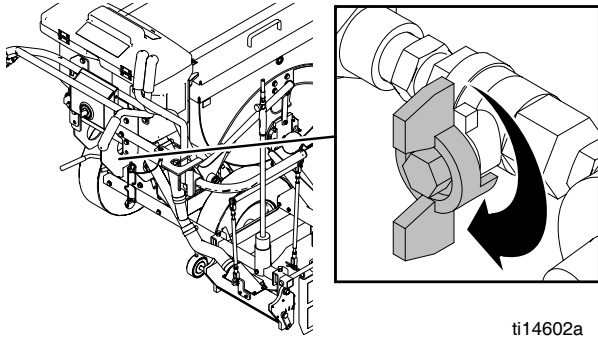

ti14602a

3. Disassemble torch hose from regulator (15mm and 20mm)

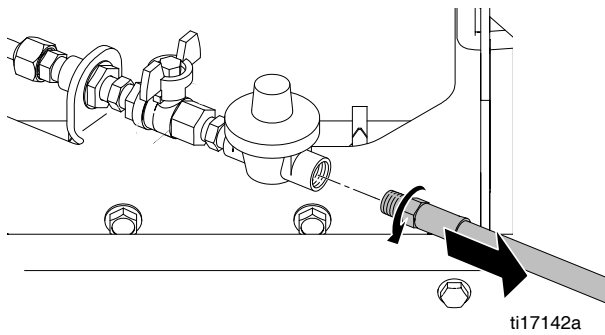

ti17142a

4. Apply sealant to male threads on tee.

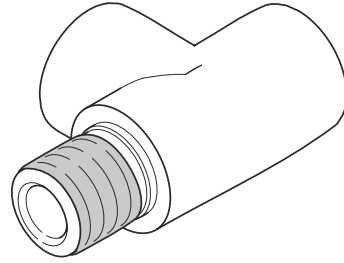

ti17138b

5. Assemble tee to regulator and orient as shown (18mm and 20mm).

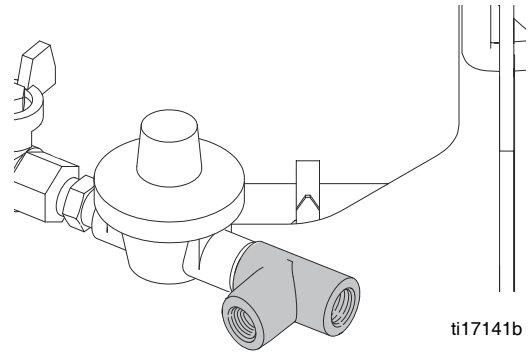

ti17141b

6. Apply sealant to torch hose threads.

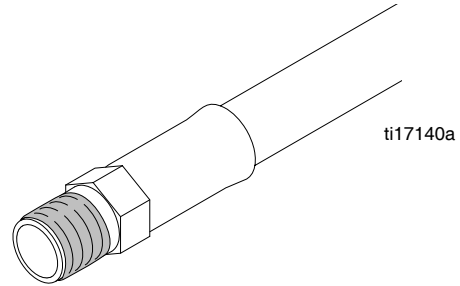

ti17140a

7. Assemble torch hose to tee (15mm and 18mm).

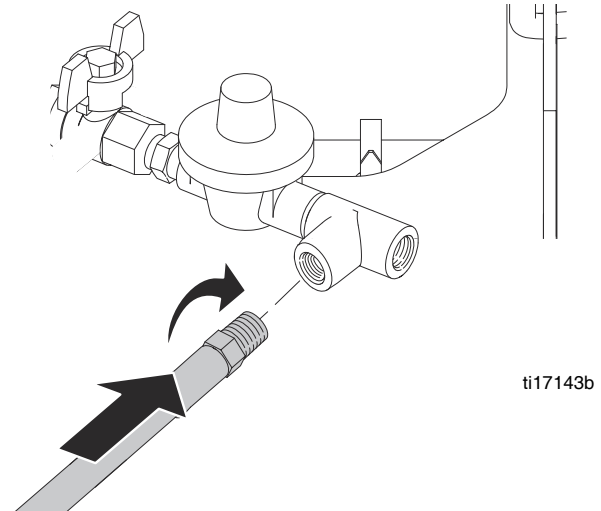

ti17143b

8. Disassemble bead dispenser bracket bolts (19mm) from ThermoLazer.

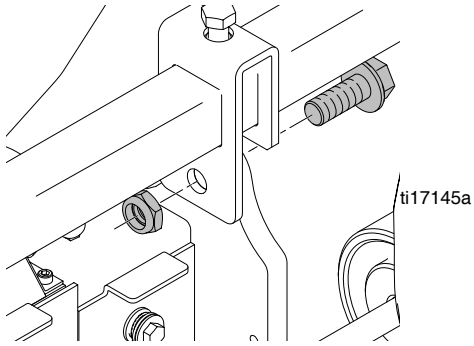

9. Slide die heat kit over bead dispenser. Align slot on bracket with bead dispenser screw head as shown. Bolt hole should also be aligned.

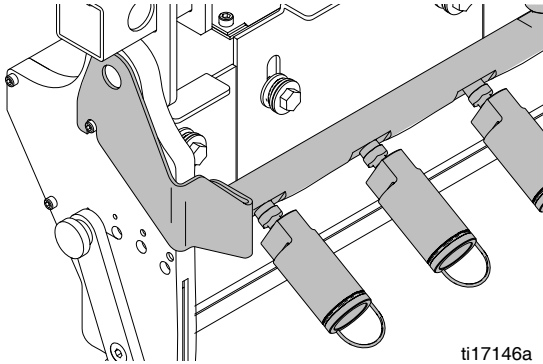

10. Assemble bead dispenser bracket bolts to unit. These bolts hold the die heat kit to the unit.

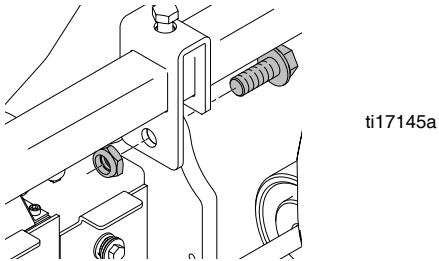

11. Route hose as shown below.

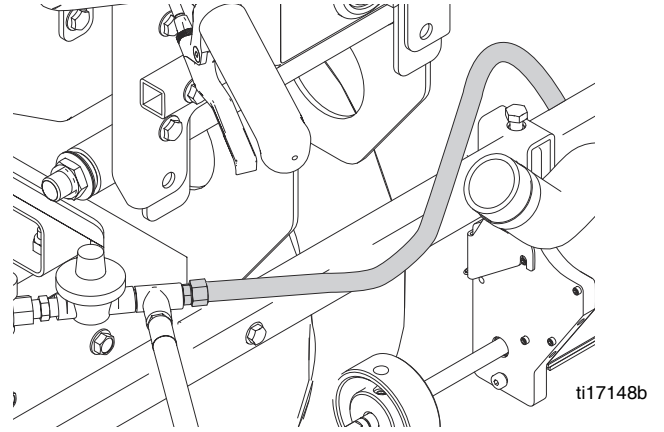

12. Attach hose swivel to tee fitting (21 mm).

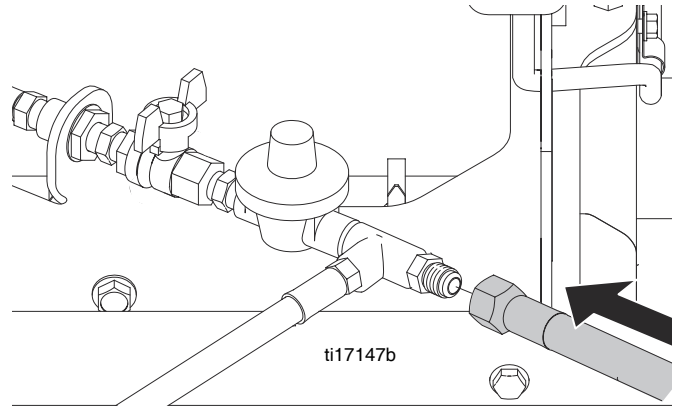

13. Install screed box rear burner lighting instructions label on screed shroud dorr below the torch lighting instruction label.

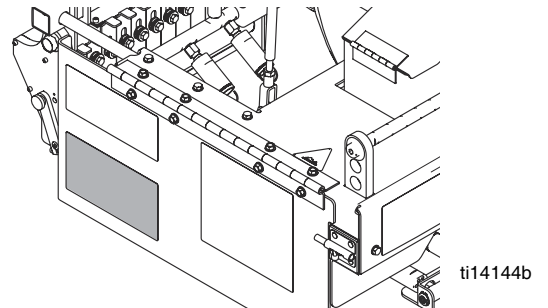

*All written and visual data contained in this document reflects the latest product information available at the time of publication.
Graco reserves the right to make changes at any time without notice.*

Original instructions. This manual contains English. MM 3A1585

Graco Headquarters: Minneapolis

International Offices: Belgium, China, Japan, Korea

GRACO INC. P.O. BOX 1441 MINNEAPOLIS, MN 55440-1441

Copyright 2008, Graco Inc. is registered to I.S. EN ISO 9001

www.graco.com

Revision B - January 2014