



OWNER'S MANUAL

820-047 Rev. B

SUPERSEDES A

This manual contains Important Warnings and Instructions. Read the manual and keep it for reference.

276

PATENT NO. 4,397,610
PATENTED 1983 Canada
Brevete 1984
FOREIGN PATENTS PENDING

1 HP, Portable, Electric

ULTIMATE NOVA™ 1000

AIRLESS PAINT SPRAYER

3000 psi (210 bar) MAXIMUM WORKING PRESSURE

Model 820-045, Series A

Basic Sprayer, without hose, gun or spray tip

Model 820-053

Includes Sprayer Model 820-045, hose, gun, self-clearing spray tip kit, and spray tip of choice.

Index

Warnings.....	2
Avertissement.....	4
Advertencia.....	6
Introduction.....	8
Setup.....	9
Operation.....	10,11
Shutdown and Care.....	11
Flushing Guidelines.....	12
Troubleshooting.....	13 to 18
Repair Section Index.....	19
Parts Lists & Drawings.....	32-34
How To Order Replacement Parts.....	33
Technical Data.....	Back Cover

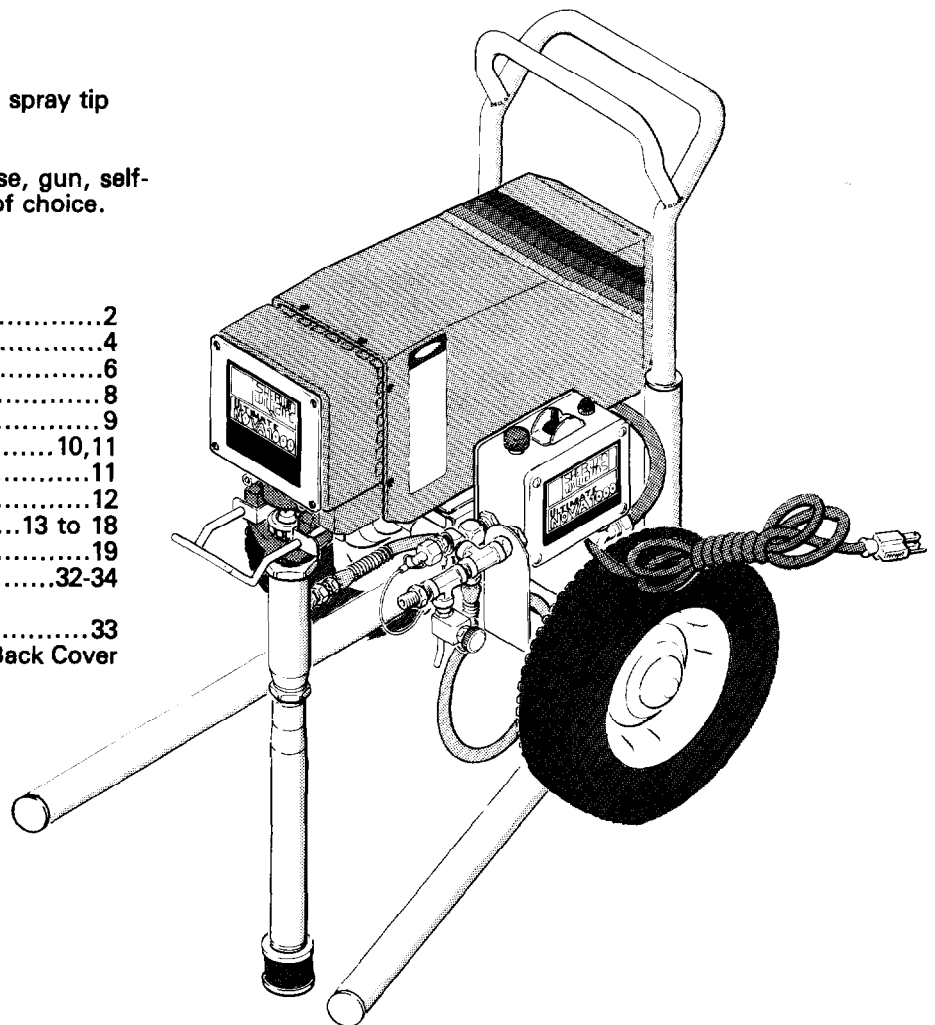

WARNING

Hazard of Using Fluids Containing Halogenated Hydrocarbons

Never use 1,1,1-trichloroethane, methylene chloride, other halogenated hydrocarbon solvents or fluids containing such solvents in this equipment. Such use could result in a serious reaction, with the possibility of explosion, which could cause death, serious bodily injury and/or substantial property damage.

Consult your fluid suppliers to ensure that the fluids being used are compatible with aluminum and zinc parts.

The SHERWIN-WILLIAMS COMPANY, CLEVELAND, OHIO 44115

WARNING

**HIGH PRESSURE SPRAY CAN CAUSE SERIOUS INJURY.
FOR PROFESSIONAL USE ONLY. OBSERVE ALL WARNINGS.**

Read and understand all instruction manuals before operating equipment.

FLUID INJECTION HAZARD

General Safety

This equipment generates very high fluid pressure. Spray from the gun, leaks or ruptured components can inject fluid through your skin and into your body and cause extremely serious bodily injury, including the need for amputation. Also, fluid injected or splashed into the eyes or on the skin can cause serious damage.

NEVER point the spray gun at anyone or at any part of the body. NEVER put hand or fingers over the spray tip. NEVER try to "blow back" paint; this is NOT an air spray system.

ALWAYS have the tip guard in place on the spray gun when spraying.

ALWAYS follow the **Pressure Relief Procedure**, below, before cleaning or removing the spray tip or servicing any system equipment.

NEVER try to stop or deflect leaks with your hand or body.

Be sure equipment safety devices are operating properly before each use.

Medical Alert—Airless Spray Wounds

If any fluid appears to penetrate your skin, get **EMERGENCY MEDICAL CARE AT ONCE. DO NOT TREAT AS A SIMPLE CUT.** Tell the doctor exactly what fluid was injected.

Note to Physician: *Injection in the skin is a traumatic injury. It is important to treat the injury surgically as soon as possible. Do not delay treatment to research toxicity. Toxicity is a concern with some exotic coatings injected directly into the blood stream. Consultation with a plastic surgeon or reconstructive hand surgeon may be advisable.*

Spray Gun Safety Devices

Be sure all gun safety devices are operating properly before each use. Do not remove or modify any part of the gun; this can cause a malfunction and result in serious bodily injury.

Safety Latch

Whenever you stop spraying, even for a moment, always set the gun safety latch in the closed or "safe" position, making the gun inoperative. Failure to set the safety latch can result in accidental triggering of the gun.

Diffuser

The gun diffuser breaks up spray and reduces the risk of fluid injection when the tip is not installed. Check diffuser operation regularly. Follow the **Pressure Relief Procedure**, below, then remove the spray tip. Aim the gun into a metal pail, holding the gun firmly to the pail. Using the lowest possible pressure, trigger the gun. If the fluid emitted is *not* diffused into an irregular stream, replace the diffuser immediately.

Tip Guard

ALWAYS have the tip guard in place on the spray gun while spraying. The tip guard alerts you to the fluid injection hazard and helps reduce, but does not prevent, the risk of accidentally placing your fingers or any part of your body close to the spray tip.

Trigger Guard

Always have the trigger guard in place on the gun when spraying to reduce the risk of accidentally triggering the gun if it is dropped or bumped.

Spray Tip Safety

Use extreme caution when cleaning or changing spray tips. If the spray tip clogs while spraying, engage the gun safety latch immediately. ALWAYS follow the **Pressure Relief Procedure** and then remove the spray tip to clean it.

NEVER wipe off build-up around the spray tip until pressure is fully relieved and the gun safety latch is engaged.

Pressure Relief Procedure

To reduce the risk of serious bodily injury, including fluid injection, splashing fluid or solvent in the eyes or on the skin, or injury from moving parts or electric shock, always follow this procedure whenever you shut off the sprayer, when checking or servicing any part of the spray system, when installing, cleaning or changing spray tips, and whenever you stop spraying. (1) Engage the gun safety latch. (2) Turn the ON/OFF switch to OFF. (3) Unplug the power supply cord. (4) Disengage the gun safety latch. (5) Hold a metal part of the gun firmly to the side of a grounded metal pail, and trigger the gun to relieve pressure. (6) Engage the gun safety latch. (7) Open the pressure relief valve, having a container ready to catch the drainage. (8) Leave the pressure relief valve open until you are ready to spray again.

If you suspect that the spray tip or hose is completely clogged, or that pressure has not been fully relieved after following the steps above, VERY SLOWLY loosen the tip guard retaining nut or hose end coupling and relieve pressure gradually, then loosen completely. Now clear the tip or hose.

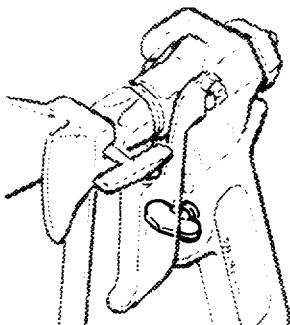

ENGAGE SAFETY LATCH

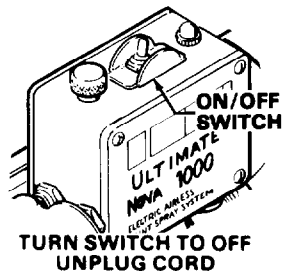

TURN SWITCH TO OFF
UNPLUG CORD

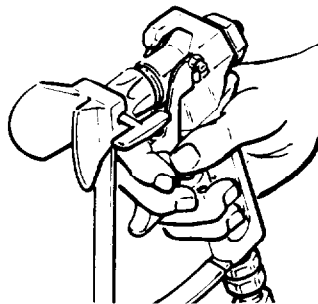

DISENGAGE SAFETY
AND TRIGGER GUN;
ENGAGE SAFETY AGAIN

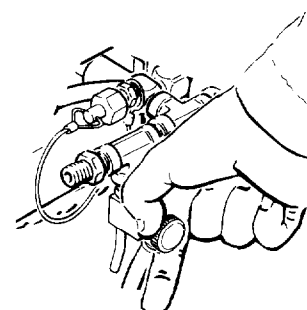

OPEN PRESSURE
RELIEF VALVE

EQUIPMENT MISUSE HAZARD

General Safety

Any misuse of the spray equipment or accessories, such as overpressurizing, modifying parts, using incompatible chemicals and fluids, or using worn or damaged parts, can cause them to rupture and result in fluid injection, splashing in the eyes or on the skin, or other serious bodily injury, fire, explosion or property damage.

NEVER alter or modify any part of this equipment; doing so could cause it to malfunction.

CHECK all spray equipment regularly and repair or replace worn or damaged parts immediately.

Always wear protective eyewear, gloves and clothing as recommended by the fluid and solvent manufacturer.

System Pressure

This sprayer can develop 3000 psi (207 bar) MAXIMUM WORKING PRESSURE. Be sure that all spray equipment and accessories are rated to withstand the maximum working pressure of this sprayer. DO NOT exceed the maximum working pressure of any component or accessory used in the system.

Fluid and Solvent Compatibility

Always read the fluid and solvent manufacturer's literature before using them in this sprayer.

HOSE SAFETY

High pressure fluid in the hoses can be very dangerous. If the hose develops a leak, split or rupture due to any kind of wear, damage or misuse, the high pressure spray emitted from it can cause a fluid injection injury or other serious bodily injury or property damage.

ALL FLUID HOSES MUST HAVE SPRING GUARDS ON BOTH ENDS! The spring guards help protect the hose from kinks or bends at or close to the coupling which can result in hose rupture.

TIGHTEN all fluid connections securely before each use. High pressure fluid can dislodge a loose coupling or allow high pressure spray to be emitted from the coupling.

NEVER use a damaged hose. Before each use, check the entire hose for cuts, leaks, abrasion, bulging cover, or damage or movement of the hose couplings. If any of these conditions exist, replace the hose immediately. DO NOT try to recouple high pressure hose or mend it with tape or any other device. A repaired hose cannot contain the high pressure fluid.

HANDLE AND ROUTE HOSES CAREFULLY. Do not pull on hoses to move equipment. Do not use fluids or solvents which are not compatible with the inner tube and cover of the hose. DO NOT expose Graco hose to temperatures above 180°F (82°C) or below -40°F (-40°C).

Hose Grounding Continuity

Proper hose grounding continuity is essential to maintaining a grounded spray system. Check the electrical resistance of your fluid hoses at least once a week. If your hose does not have a tag on it which specifies the maximum electrical resistance, contact the hose supplier or manufacturer for the maximum resistance limits. Use a resistance meter in the appropriate range for your hose to check the resistance. If the resistance exceeds the recommended limits, replace it immediately. An ungrounded or poorly grounded hose can make your system hazardous. Also read FIRE OR EXPLOSION HAZARD.

FIRE OR EXPLOSION HAZARD

Static electricity is created by the high velocity flow of fluid through the pump and hose. If every part of the spray equipment is not properly grounded, sparking may occur, and the system may become hazardous. Sparking may also occur when plugging in or unplugging a power supply cord. Sparks can ignite fumes from solvents and the fluid being sprayed, dust particles and other flammable substances, whether you are spraying indoors or outdoors, and can cause a fire or explosion and serious bodily injury and property damage. Always plug the sprayer into an outlet at least 20 feet (6 m) away from the sprayer and the spray area. Do not plug in or unplug any power supply cords in the spray area when there is any chance of igniting fumes still in the air.

If you experience any static sparking or even a slight shock while using this equipment, **STOP SPRAYING IMMEDIATELY**. Check the entire system for proper grounding. Do not use the system again until the problem has been identified and corrected.

Grounding

To reduce the risk of static sparking, ground the sprayer and all other spray equipment used or located in the spray area. CHECK your local electrical code for detailed grounding instructions for your area and type of equipment. BE SURE to ground all of this spray equipment:

1. *Sprayer:* plug the power supply cord, or extension cord, each equipped with an undamaged three-prong plug, into a properly grounded outlet. Do not use an adapter. All extension cords must have three wires and be rated for 15 amps.
2. *Fluid hoses:* use only grounded hoses with a maximum of 500 feet (150 m) combined hose length to ensure grounding continuity. Refer to **Hose Grounding Continuity**.
3. *Spray gun:* obtain grounding through connection to a properly grounded fluid hose and sprayer.
4. *Object being sprayed:* according to local code.
5. *Fluid supply container:* according to local code.
6. *All solvent pails* used when flushing, according to local code. Use only metal pails, which are conductive. Do not place the pail on a non-conductive surface, such as paper or cardboard, which interrupts the grounding continuity.
7. *To maintain grounding continuity when flushing or relieving pressure,* always hold a metal part of the gun firmly to the side of a grounded metal pail, then trigger the gun.

Flushing Safety

Reduce the risk of injection injury, static sparking, or splashing by following the specific flushing procedure given on page 12 of this manual. Follow the **Pressure Relief Procedure** on page 4, and *remove the spray tip before flushing*. Hold a metal part of the gun firmly to the side of a metal pail and use the lowest possible fluid pressure during flushing.

MOVING PARTS HAZARD

Moving parts can pinch or amputate your fingers or other body parts. KEEP CLEAR of moving parts when starting or operating the sprayer. Unplug the sprayer, and follow the **Pressure Relief Procedure** on page 2, before checking or servicing any part of the sprayer to prevent it from starting accidentally.

IMPORTANT

United States Government safety standards have been adopted under the Occupational Safety and Health Act. These standards—particularly the General Standards, Part 1910, and the Construction Standards, Part 1926—should be consulted.

AVERTISSEMENT

La pulvérisation à haute pression peut causer des blessures très graves.

Réservé exclusivement à l'usage professionnel. Observer toutes les consignes de sécurité.

Bien lire et bien comprendre tous les manuels d'instructions avant d'utiliser le matériel.

RISQUES D'INJECTION

Consignes générales de sécurité

Cet appareil produit un fluide à très haute pression. Le fluide pulvérisé par le pistolet ou le fluide sous pression provenant de fuites ou de ruptures peut pénétrer sous la peau ou à l'intérieur du corps et entraîner des blessures très graves, voir même une amputation. Même sans être sous pression, le fluide éclaboussant ou entrant dans les yeux peut aussi entraîner des blessures graves.

NE JAMAIS pointer le pistolet vers quelqu'un ou vers une partie quelconque du corps. NE JAMAIS mettre la main ou les doigts sur l'ajutage du pulvérisateur. NE JAMAIS essayer de "refouler" la peinture. Cet appareil N'est PAS un compresseur pneumatique.

TOUJOURS garder la protection de l'ajutage en place sur le pistolet pendant la pulvérisation.

TOUJOURS observer la **Marche à Suivre pour Détendre la Pression** donnée plus loin, avant de nettoyer ou d'enlever l'ajutage du pulvérisateur, ou d'effectuer un travail quelconque sur une partie de l'appareil.

NE JAMAIS essayer d'arrêter ou de dévier les fuites avec la main ou le corps.

Avant chaque utilisation, bien s'assurer que les dispositifs de sécurité fonctionnent correctement.

Soins médicaux

En cas de pénétration de fluide sous la peau: **DEMANDER IMMEDIATEMENT DES SOINS MEDICAUX D'URGENCE. NE PAS SOIGNER CETTE BLESSURE COMME UNE SIMPLE COUPURE.**

Avis au médecin: La pénétration des fluides sous la peau est un traumatisme. Il est important de traiter chirurgicalement cette blessure immédiatement. Ne pas retarder le traitement pour effectuer des recherches sur la toxicité. Certains revêtements exotiques sont dangereusement toxiques quand ils sont injectés directement dans le sang. Il est souhaitable de consulter un chirurgien esthétique ou un chirurgien spécialisé dans la reconstruction des mains.

Dispositifs de sécurité du pistolet

Avant chaque utilisation, bien s'assurer que tous les dispositifs de sécurité du pistolet fonctionnent correctement. Ne pas

enlever ni modifier une partie quelconque du pistolet; ceci risquerait d'entraîner un mauvais fonctionnement et des blessures graves.

Verrou de sécurité

A chaque fois que l'on s'arrête de pulvériser, même s'il s'agit d'un court instant, toujours mettre le verrou de sécurité du pistolet sur la position "fermée" ou "sécurité" ("safe") pour empêcher le pistolet de fonctionner. Si le verrou de sécurité n'est pas mis, le pistolet peut se déclencher accidentellement. Voir la Fig. 3.

Diffuser

Le diffuseur du pistolet sert à diviser le jet et à réduire les risques d'injection accidentelle quand l'ajutage n'est pas en place. Vérifier le fonctionnement du diffuseur régulièrement. Pour cette vérification, détendre la pression en observant la **Marche à Suivre pour Détendre la Pression** donnée plus loin puis enlever l'ajutage du pulvérisateur. Pointer le pistolet dans un seau en métal, en le maintenant fermement contre le seau. Puis, en utilisant la pression la plus faible possible, appuyer sur la gachette du pistolet. Si le fluide projeté n'est pas diffusé sous forme de jet irrégulier, remplacer immédiatement le diffuseur.

Protection de l'ajutage

TOUJOURS maintenir la protection de l'ajutage en place sur le pistolet du pulvérisateur pendant la pulvérisation. La protection de l'ajutage attire l'attention sur les risques d'injection et contribue à réduire, mais n'évite pas le risque, que les doigts ou une partie quelconque du corps ne passent accidentellement à proximité immédiate de l'ajutage du pulvérisateur.

Consignes de sécurité concernant l'ajutage du pulvérisateur

Faire extrêmement attention à l'occasion du nettoyage ou du remplacement des ajutages du pulvérisateur. Si l'ajutage se bouche pendant la pulvérisation, mettre immédiatement le verrou de sécurité du pistolet. TOUJOURS bien observer la **Marche à Suivre pour Détendre la Pression** puis enlever l'ajutage du pulvérisateur pour le nettoyer.

NE JAMAIS essayer ce qui s'est accumulé autour de l'ajutage du pulvérisateur avant que la pression ne soit complètement tombée et que le verrou de sécurité du pistolet ne soit engagé.

Marche à Suivre pour Détendre la Pression

Pour réduire les risques de blessures graves, y compris les blessures par injection de fluide ou celles causées par des éclaboussures dans les yeux ou sur la peau, des pièces en mouvement ou par électrocution, toujours bien observer cette marche à suivre à chaque fois que l'on arrête le pulvérisateur, à l'occasion de la vérification ou de la réparation d'une pièce de l'appareil de pulvérisation, à l'occasion de l'installation, du nettoyage ou du remplacement des ajutages et d'une manière générale à chaque arrêt. 1) Engager le verrou de sécurité du pistolet. 2) Mettre l'interrupteur Marche-Arrêt sur ARRET ("OFF"). 3) Débrancher le cordon d'alimentation. 4) Désengager le verrou de sécurité du pistolet. 5) En maintenant une partie métallique du pistolet fermement appuyée contre le côté d'un seau en métal, appuyer sur la gachette du pistolet pour libérer la pression. 6) Engager le verrou de sécurité du pistolet. 7) Ouvrir la soupape de sécurité en prenant soin d'avoir un récipient prêt à récupérer le liquide. 8) Laisser la soupape ouverte jusqu'à ce que le pulvérisateur soit de nouveau prêt à être utilisé.

Si l'on soupçonne que l'ajutage du pulvérisateur ou le tuyau est complètement bouché, ou que la pression n'a pas été complètement libérée après avoir procédé aux opérations ci-dessus, desserrer TRES LENTEMENT l'écrou de retenue de la protection de l'ajutage ou le raccord du bout du tuyau et libérer progressivement la pression, puis terminer le desserrage. On peut maintenant déboucher l'ajutage ou le tuyau.

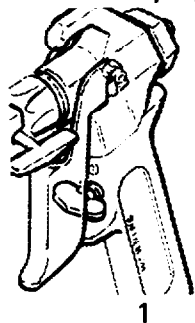

1

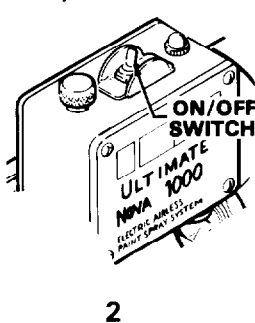

2

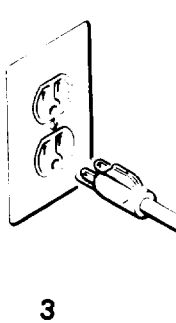

3



4,5,6

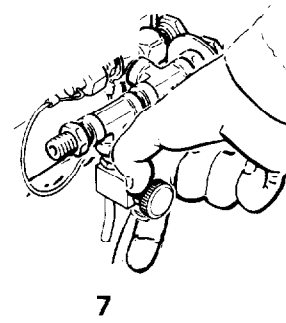

7

RISQUES EN CAS DE MAUVAISE UTILISATION DU MATERIEL

Consignes générales de sécurité

Toute utilisation anormale de l'appareil de pulvérisation ou des accessoires comme, par exemple, la mise sous une pression excessive, les modifications de pièces, l'utilisation de produits chimiques et de matières incompatibles et l'utilisation de pièces usées ou abîmées peut causer des dégâts à l'appareil ou des ruptures de pièces et entraîner une injection de liquide ou d'autres blessures sérieuses, un incendie, une explosion ou d'autres dégâts.

NE JAMAIS altérer ou modifier une pièce de cet appareil; ceci risquerait d'entraîner son mauvais fonctionnement.

VERIFIER régulièrement tout l'appareil de pulvérisation et ses équipements et réparer ou remplacer immédiatement les pièces usées ou abîmées.

MESURES DE SECURITE CONCERNANT LES TUYAUX FLEXIBLES

Le fluide à haute pression circulant dans les tuyaux peut être très dangereux. En cas de fuite sur le tuyau, de fissure, déchirure ou rupture à la suite de l'usure, de dégâts ou d'une mauvaise utilisation, les projections de fluide haute pression qui en proviennent peuvent entraîner des blessures graves par pénétration sous la peau ou par contact, ainsi que des dégâts matériels.

TOUS LES TUYAUX FLEXIBLES DOIVENT AVOIR DES RESSORTS SPIRALE DE PROTECTION AUX 2 BOUTS! Les spirales de protection contribuent à éviter la formation de pliures, de boucles ou de nœuds sur les tuyaux qui pourraient entraîner la rupture du tuyau à l'endroit du raccord ou à son voisinage.

SERRER FERMEMENT tous les raccords avant chaque utilisation. Le fluide sous pression peut faire sauter un raccord desserré ou produire un jet à haute pression s'échappant par le raccord.

NE JAMAIS utiliser un tuyau endommagé. Avant chaque utilisation, vérifier entièrement chaque tuyau pour déceler les coupures, fuites, abrasions, boursoffures de l'enveloppe ou toute autre détérioration ou jeu des raccords. Si l'on constate l'une de ces détériorations, il faut remplacer le tuyau immédiatement. NE PAS essayer de refaire le raccord d'un tuyau

RISQUES D'INCENDIE OU D'EXPLOSION

De l'électricité statique est produite par le passage du fluide à grande vitesse dans la pompe et dans les tuyaux. Si toutes les pièces de l'appareil de pulvérisation ne sont pas convenablement reliées à la masse ou à la terre, des étincelles peuvent se produire et l'appareil risque d'être dangereux. Des étincelles peuvent également se produire à l'occasion du branchement ou du débranchement du cordon d'alimentation. Les étincelles sont suffisantes pour allumer les vapeurs de solvants et le fluide pulvérisé, les fines particules de poussière ainsi que d'autres substances inflammables, quand on pulvérise à l'intérieur ou à l'extérieur, et elles peuvent causer un incendie ou une explosion, ainsi que des blessures graves et des dégâts matériels. Toujours brancher le pulvérisateur dans une prise se trouvant à au moins 6 m (20 pieds) de l'appareil et de l'endroit où se fait la pulvérisation. Ne pas brancher ou débrancher un cordon d'alimentation quel qu'il soit dans la zone où se fait la pulvérisation quand il y a le moindre risque que des vapeurs encore présentes dans l'air prennent feu.

S'il se produit des étincelles d'électricité statique, ou si vous ressentez la moindre décharge, **ARRETEZ IMMEDIATEMENT LA PULVERISATION.** Vérifiez que le système entier est bien mis à la terre. Ne vous servez pas du système avant que le problème soit identifié et corrigé.

Mise à la terre ou à la masse

Pour réduire les risques de production d'étincelles d'électricité statique, le pulvérisateur et tous les équipements utilisés ou se trouvant dans la zone de pulvérisation doivent être reliés à la terre ou à la masse. Pour connaître le détail des instructions de mise à la terre dans la région et le type particulier d'équipement, **CONSULTER** le code ou les réglementations électriques locales. **S'ASSURER** que tous les équipements de pulvérisation suivants sont bien reliés à la terre:

1. **Pulvérisateur:** Brancher le cordon d'alimentation ou le rallonge qui doivent être équipés d'une prise à 3 fiches en bon état, dans une prise de courant convenablement mise à la terre. Ne pas utiliser d'adaptateur. Toutes les rallonges doivent avoir 3 fils et être prévues pour 15 ampères.

Pression

Ce pulvérisateur peut produire une **PRESSION MAXIMUM DE TRAVAIL 207 bar (3000 lb/po.²)**. S'assurer que tous les éléments du pulvérisateur et ses accessoires sont conçus pour résister à la pression maximum de travail de ce pulvérisateur. **NE PAS** dépasser la pression maximum de travail d'aucun des éléments ou accessoires utilisés avec cet appareil.

Compatibilité chimique des corps

BIEN S'ASSURER que tous les corps des solvants utilisés sont chimiquement compatibles avec les parties mouillées indiquées dans les "Données techniques", au dos de la couverture. Toujours lire soigneusement les documents et brochures du fabricant des fluides et solvants utilisés avant de s'en servir dans ce pulvérisateur.

haute pression ni de réparer le tuyau avec du ruban adhésif ou par tout autre moyen. Un tuyau réparé ne peut pas résister au fluide sous pression.

MANIPULER LES TUYAUX AVEC PRECAUTION ET CHOISIR SOIGNEUSEMENT LEUR CHEMIN. Ne pas déplacer le fluide en tirant sur le tuyau. Ne pas utiliser de fluides ou de solvants qui ne sont pas compatibles avec l'enveloppe intérieure ou extérieure du tuyau. **NE PAS** exposer le tuyau à des températures supérieures à 82°C (180°F) ou inférieures à -40°C (-40°F).

Continuité de la mise à la terre des tuyaux

Une bonne continuité de la mise à la terre des tuyaux est essentielle pour maintenir la mise à la terre de l'ensemble de vaporisation. Vérifiez la résistance électrique de vos tuyaux à fluides et à air, au moins une fois par semaine. Si votre tuyau ne comporte pas d'étiquette qui précise la résistance électrique maximum, prenez contact avec le fournisseur de tuyaux ou la fabricant pour avoir les limites de résistance maximum. Utilisez un mètre de résistance de la gamme appropriée pour votre tuyau et vérifiez la résistance. Si celle-ci dépasse les limites recommandées, remplacez le tuyau immédiatement. Un tuyau sans mise à la terre ou avec une mise à la terre incorrecte peut entraîner des risques pour votre système. Lisez aussi **LES RISQUES D'INCENDIE OU D'EXPLOSION** ci-dessus.

2. **Tuyaux flexibles:** Afin d'assurer la continuité de la mise à la terre, n'utiliser que des tuyaux comportant une mise à la terre et ayant une longueur maximum combinée de 150 m (1500 pieds). Se reporter également au paragraphe "Continuité du circuit de mise à la terre des tuyaux".

3. **Pistolet:** Réaliser la mise à la terre en le raccordant à un tuyau flexible et à un pulvérisateur déjà convenablement reliés à la terre.

4. **Récipient d'alimentation:** observer le code ou les réglementations locales.

5. **Objets, matériel ou surfaces recevant la pulvérisation:** observer le code ou les réglementations locales.

6. **Tous les seaux de solvants** utilisés pour le rincage: observer le code ou les réglementations locales. **N'utiliser que des seaux métalliques** conducteurs de l'électricité. Ne pas mettre le seau sur une surface non conductrice comme sur du papier ou du carton car cela interromprait la continuité de la mise à la terre.

7. **Pour conserver la continuité de la mise à la terre quand on rince le matériel ou quand on libère la pression,** toujours maintenir une partie métallique du pistolet fermement appuyée contre le côté d'un seau *en métal* puis appuyer sur la détente du pistolet.

Mesures de Sécurité concernant le Rincage

Pour réduire les risques de blessures par pénétration de la peau et les risques dus aux étincelles d'électricité statique ou aux éclaboussures, observer la marche à suivre pour le rincage donnée à la page 12 de ce manuel. Observer la "**Marche à Suivre pour Détendre la Pression**" donnée à la page 4 en **enlever l'ajutage du pulvérisateur avant le rincage.** Maintenir une partie métallique du pistolet fermement appuyée contre le côté d'un seau *en métal* et utiliser la pression la plus faible possible pendant le rincage.

ADVERTENCIA

**EL ROCIADO A ALTA PRESION PUEDE CAUSAR GRAVES LESIONES.
SOLO PARA USO PROFESIONAL. RESPETE LOS AVISOS DE ADVERTENCIA.**

Lea y entienda todo el manual de instrucciones antes de manejar el equipo.

PELIGRO DE INYECCION DE FLUIDO

Seguridad general

Este equipo genera un fluido a una presión muy alta. El rociado de la pistola, los escapes de fluido o roturas de los componentes pueden inyectar fluido en la piel y el cuerpo y causar lesiones extremadamente graves, incluyendo a veces la necesidad de amputación. También, el fluido inyectado o salpicado en los ojos puede causar graves daños.

NUNCA apuntar la pistola hacia alguien o alguna parte del cuerpo. NUNCA colocar la mano o los dedos encima de la boquilla. NUNCA tratar de "hacer retornar la pintura"; este NO es un sistema de rociado de aire.

SIEMPRE tener colocado el protector de la boquilla en la pistola mientras se está pulverizando.

SIEMPRE seguir el procedimiento de descarga de presión, dado más abajo, antes de limpiar o sacar la boquilla o de dar servicio a cualquier equipo del sistema.

NUNCA tratar de parar o desviar los escapes con la mano o el cuerpo.

Asegurar que todos los aparatos de seguridad del equipo están funcionando bien antes de cada uso.

Tratamiento médico

Si pareciera que un poco de fluido penetró la piel, conseguir **TRATAMIENTO MEDICO DE URGENCIA DE INMEDIATO. NO TRATAR LA HERIDA COMO UN SIMPLE CORTE.** Decir al médico exactamente cual fluido fue.

Aviso al médico: Si se llega a inyectar este fluido en la piel se causa una lesión traumática. Es importante tratar quirúrgicamente la lesión a la brevedad posible. No demorar el tratamiento para investigar la toxicidad. La toxicidad es algo de suma importancia en algunas pinturas exóticas cuando se inyectan directamente al torrente sanguíneo. Será conveniente consultar a un especialista en cirugía plástica o reconstructiva de las manos.

Aparatos de seguridad de la pistola pulverizadora
Asegurar que todos los aparatos protectores de la pistola están funcionando bien antes de cada uso. No sacar ni modificar ninguna pieza de la pistola pues podría causar el malfuncionamiento de la misma con las consiguientes lesiones personales.

Pestillo de seguridad

Cada vez que se deje de pulverizar, aunque sea por un breve momento, siempre colocar el pestillo de seguridad en la posición "cerrada", lo que deja la pistola inoperante. El no hacerlo puede llevar al disparo imprevisto de la pistola.

Difusor

El difusor de la pistola dispersa el chorro pulverizado y reduce el riesgo de inyección cuando no está instalada la boquilla. Revisar con regularidad el funcionamiento del difusor. Seguir el procedimiento de descarga de presión, dado más abajo, y después sacar la boquilla. Apuntar la pistola a un balde metálico, sosteniéndola bien firme contra él. Utilizando la presión más bajo posible, disparar la pistola. Si el fluido emitido *no sale disperso* en un chorro irregular, reemplazar de inmediato el difusor.

Protector de la boquilla

SIEMPRE tener el protector de la boquilla colocado en la pistola mientras se está pulverizando. Este protector llama la atención contra el peligro de inyección y ayuda a reducir, pero no evita, la colocación accidental de los dedos o cualquier otra parte del cuerpo cerca de la boquilla.

Seguridad de la boquilla pulverizadora

Tener mucho cuidado al limpiar o cambiar las boquillas. Si llegara a obstruirse mientras está pulverizando, enganchar el pestillo de la pistola de inmediato. SIEMPRE seguir el procedimiento de descarga de presión y después sacar la boquilla para limpiarla.

NUNCA limpiar la acumulación de pintura alrededor de la boquilla antes de que se haya descargado por completo la presión y el pestillo esté enganchado.

Procedimiento de descarga de presión

Para reducir el riesgo de sufrir graves lesiones corporales, incluyendo inyección o lesiones causadas por piezas en movimiento o choque eléctrico, siempre seguir este procedimiento al apagar la máquina pulverizadora, al revisar o dar servicio a cualquier parte del sistema de pulverización, al instalar, limpiar o cambiar las boquillas, y cada vez que se deja de pulverizar. (1) Enganchar el pestillo de la pistola. (2) Mover el interruptor eléctrico (ON/OFF) a la posición OFF (apagado). (3) Desenchufar el cordón eléctrico. (4) Desenganchar el pestillo de la pistola. (5) Sujetar una parte metálica de la pistola bien firme contra un balde de metal, y disparar la pistola para descargar la presión. (6) Enganchar el pestillo de la pistola. (7) Abrir la válvula de presión y tener listo un recipiente para recibir la pintura. (8) Dejar la válvula de alivio de presión abierta hasta que se esté nuevamente listo para pulverizar.

Si se sospecha que la boquilla o la manguera está completamente obstruida, o que no se ha descargado por completo la presión después de haber seguido el procedimiento anterior, aflojar MUY LENTAMENTE la tuerca de retención del protector de la boquilla o acoplamiento de la punta de la manguera y descargar gradualmente la presión, después, aflojarlo por completo. Luego, despejar la boquilla o la manguera.



1

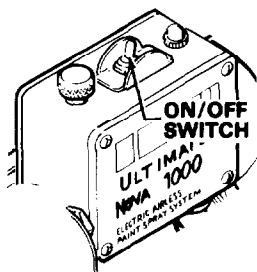

2

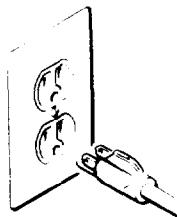

3



4,5,6

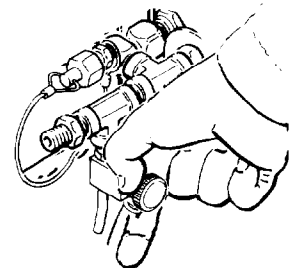

7

PELIGRO POR MAL USO DEL EQUIPO

Seguridad general

Cualquier mal uso del equipo pulverizador o los accesorios, tal como sobrepresurización, modificación de piezas, uso de materiales y productos químicos incompatibles, o utilización de piezas dañadas o desgastadas, pueden hacer que se rompan y causen la inyección de fluido u otras lesiones corporales graves, incendio, explosión o daño a la propiedad.

NUNCA alterar o modificar ninguna pieza de este equipo; el hacerlo podría causar una avería.

REVISAR con regularidad el equipo pulverizador y reparar o reemplazar de inmediato las piezas dañadas o desgastadas.

Presión del sistema

Esta pulverizadora puede desarrollar 207 barías (3000 psi) de **PRESIÓN DE TRABAJO MÁXIMA**. Asegurar que todo el equipo pulverizador y sus accesorios tienen la capacidad para aguantar la presión máxima de trabajo de esta pulverizadora. NO exceder la presión máxima de trabajo de ningún componente o accesorio de este sistema.

Compatibilidad de fluido

ASEGURAR que todos los fluidos y solventes usados son químicamente compatibles con las piezas mojadas ilustradas en la hoja de datos técnicos en la contratapa. Siempre leer las instrucciones del fabricante del fluido y solvente antes de usarlos en esta pulverizadora.

SEGURIDAD EN EL USO DE LAS MANGUERAS

El fluido que escapa a alta presión por las mangueras puede ser muy peligroso. Si en la manguera se desarrolla un escape, una rotura o rajadura debido a cualquier tipo de desgaste, daño o maltrato, el chorro a alta presión emitido por allí puede causar una lesión por inyección u otras lesiones corporales graves o daños a la propiedad.

¡TODAS LAS MANGUERAS PARA FLUIDOS TIENEN QUE TENER GUARDAS DE RESORTE EN AMBOS EXTREMOS! Estas protegen las mangueras contra dobleces o retorcimientos en los acoplamientos o cerca de ellos, los que podrían traducirse en roturas de la manguera.

Antes de usarlas, APRETAR bien firmes todas las conexiones. El fluido a alta presión puede desalojar un acoplamiento suelto o dejar que por él escape un chorro a alta presión.

NUNCA usar una manguera que está dañada. Siempre, revisarla en busca de cortaduras, escapes, abrasión, cubierta abultada, o acoplamientos sueltos o dañados. Si llegara a encontrarse cualquiera de estas condiciones, reemplazar de inmediato la manguera. NO intentar reacomodar una manguera de alta presión o enmendarla con cinta adhesiva u otro material similar. Una manguera que ha sido remendada no aguante el fluido a alta presión.

MANEJAR Y PASAR CUIDADOSAMENTE LAS MANGUERAS. No tirar de las mangueras para mover el equipo. No usar fluidos o solventes que sean incompatibles con el tubo interno y la cubierta de la manguera. NO exponer las mangueras a temperaturas sobre 82°C (180°F) o bajo -40°C (-40°F).

Continuidad del circuito de puesta a tierra de la manguera

La continuidad del circuito de puesta a tierra apropiado es esencial para mantener conectado a tierra el sistema pulverizador. Es indispensable revisar la resistencia eléctrica máxima de las mangueras de aire y de fluido por lo menos una vez a la semana. Si la manguera no tiene una etiqueta en la cual se especifica la resistencia eléctrica máxima, ponerse en contacto con el proveedor o fabricante de la manguera para la información sobre los límites de resistencia. Usar un metro de resistencia en la gama apropiada para comprobar la resistencia; si excede los límites recomendados, reemplazarla de inmediato. Es muy arriesgado tener una manguera sin puesta a tierra o con la puesta a tierra en malas condiciones. Leer también la información sobre **RIESGO DE INCENDIO O EXPLOSION**, más arriba.

PELIGRO DE INCENDIO O EXPLOSION

El flujo a alta velocidad del fluido al pasar por la bomba y manguera crea electricidad estática. Si todas las partes del equipo pulverizador no tienen buena tierra, pueden ocurrir chispas, convirtiendo al sistema en algo peligroso. También, pueden producirse chispas al enchufar o desenchufar el cordón eléctrico. Estas chispas pueden inflamar los vapores de los solventes y el chorro de fluido pulverizado, partículas de polvo y otras sustancias inflamables, sea al aire libre o bajo techo, lo que podría causar una explosión o incendio y graves lesiones corporales y daños a la propiedad. Enchufar siempre la pulverizadora a un tomacorriente que se encuentre a por lo menos 6 m (20 pies) de la máquina y del área que se va a rociar. No enchufar o desenchufar ningún cordón eléctrico en el lugar donde se está rociando cuando todavía exista la posibilidad de que queden vapores inflamables en el aire.

Si ocurre una chispa de electricidad estática o incluso un ligero choque eléctrico mientras se usa el equipo, **DEJAR DE PULVERIZAR DE INMEDIATO**. Revisar todo el sistema en busca de una tierra apropiada. No usar de nuevo el sistema hasta haber identificado y solucionado el problema.

Puesta a tierra

Para reducir el riesgo de chispas estáticas, conectar a tierra la pulverizadora y todo el otro equipo de pulverizar que se use o se encuentre en el lugar que se va a rociar. **CONSULTAR** el código eléctrico de la localidad para las instrucciones sobre las conexiones a tierra exigidas para la zona y tipo de equipo. **ASEGURAR** de conectar a tierra todo este equipo pulverizador:

1. **Pulverizadora:** enchufar el cordón eléctrico, o cable extensor, cada uno con un enchuf de tres patas en buen estado, a un tomacorriente con puesta a tierra apropiado. No usar un adaptador. Todos los cables extensores tienen que tener tres hilos y una capacidad de 15 amperios.
2. **Mangueras para fluidos:** usar solamente mangueras con puesta a tierra de una longitud combinada de 150 m (500 pies), para asegurar buena continuidad a tierra. Referirse también al párrafo sobre **continuidad a tierra de la manguera**.
3. **Pistola:** hacer la puesta a tierra conectándola a una manguera de fluido y pulverizadora bien conectadas a tierra.
4. **Suministrar un recipiente:** de acuerdo al código de la localidad.
5. **Objeto que se está rociando:** de conformidad con el código local.
6. **Todos los baldes de solvente** usados durante el lavado, de conformidad con el código local. Usar **solamente baldes de metal**, que sean conductivos. No colocar el balde en una superficie no conductiva, como papel o cartón, que interrumpe la continuidad a tierra.
7. **Para mantener la continuidad a tierra durante el lavado o descarga de presión**, siempre apoyar una parte metálica de la pistola bien firme contra el costado del **balde de metal**, después apretar el gatillo.

Seguridad durante el lavado

Para reducir el riesgo de que se inyecte o salpique fluido en la piel, o que ocurra una descarga de electricidad estática, siempre seguir las **INSTRUCCIONES PARA EL LAVADO**, dadas en la página 12. Seguir el **procedimiento de descarga de presión** en la página 6, y quitar la **boquilla rociadora antes de lavar**. Apoyar una parte metálica de la pistola bien firme contra el costado de un **balde de metal** y usar la presión más baja posible de fluido durante el lavado.

PELIGRO DE LAS PIEZAS MOVILES

Las piezas en movimiento pueden pinchar o amputar dedos u otras partes del cuerpo. **MANTENERSE ALEJADO** de las piezas en movimiento durante el arranque o funcionamiento de la pulverizadora. Desenchufar la pulverizadora y descargar la presión antes de revisar o dar servicio, a cualquier parte de pulverizadora, para impedir que arranque inesperadamente.

IMPORTANT

Se han adoptado las normas de seguridad del gobierno de los Estados Unidos de Norteamérica bajo el Acta de Seguridad y Salud Ocupacional. Deberán consultarse estas normas, en especial las Generales, Parte 1910, y las Normas de Construcción, Parte 1926.

INTRODUCTION
ULTIMATE NOVA™ BASIC COMPONENTS
Model 820-063 shown

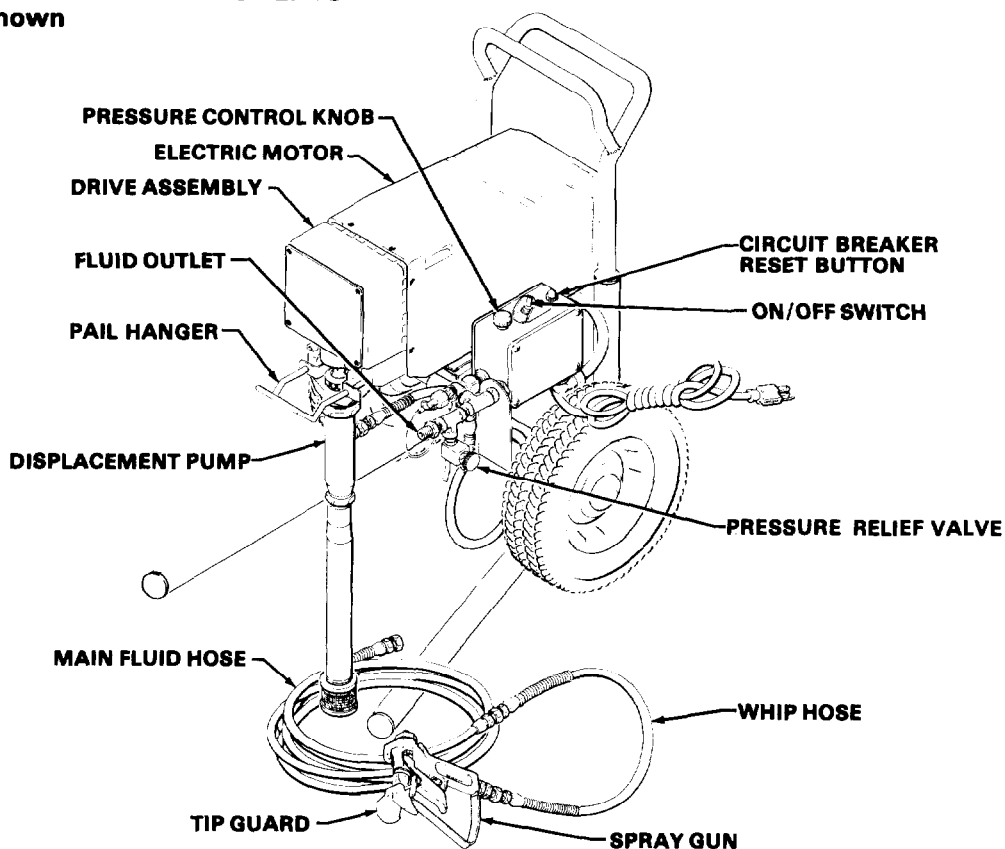

Your new Ultimate Nova™ 1000 Sprayer functions and operates differently than other airless paint sprayers. This section will help you become familiar with the sprayer before operating it.

Pressure Control

The pressure control includes an ON/OFF switch for the sprayer, the pressure adjusting control knob, a pressure sensing device, and a current overload circuit breaker with a manual reset button. Its function is to control the motor speed so that the sprayer maintains constant fluid pressure at the pump outlet.

Motor

The DC motor has sealed bearings and replaceable motor brushes. Its function is to drive the displacement pump at the rate needed to supply sufficient paint volume at the selected pressure.

Working together, the pressure control and motor cause the pump to cycle whenever there is fluid or pressure demand. When the pump is cycling, the motor sounds like an automobile starter cranking. When the pump is not cycling, the motor hums, hums intermittently, or appears to have shut itself off. However, there will still be power to the sprayer and it will stay pressurized and ready to use unless you manually shut it off and relieve pressure.

Because the motor is DC, it is less sensitive to low voltage or voltage fluctuations than an AC motor, and a heavy gauge extension cord of up to 150 feet (45 m) can be used.

Drive Assembly

The sealed drive assembly transfers power from the DC motor to the displacement pump.

Displacement Pump

The positive displacement, volume-balanced pump provides equal fluid delivery on both the up and down pump strokes. The pump has a wet-cup which, when filled with Graco Throat Seal Liquid, helps prevent damage to the throat packings and piston rod.

Hoses

The grounded, nylon spray hoses have spring guards on both ends. The 50 foot (15.2 m) hose has a 1/4 in. ID. The 3 foot (0.9 m), 3/16 in. ID whip hose allows flexible gun movement. The nylon hose material acts as a pulsation dampener to absorb pressure fluctuations.

Spray Gun & Reverse-A-Clean® III Spray Tip

The high pressure spray gun has a trigger safety which prevents accidental triggering when it is engaged (see below). The Reverse-A-Clean III spray tip uses high pressure fluid to remove clogs from the spray tip without removing it from the gun. It includes a safety tip guard which helps reduce the risk of injection injury.

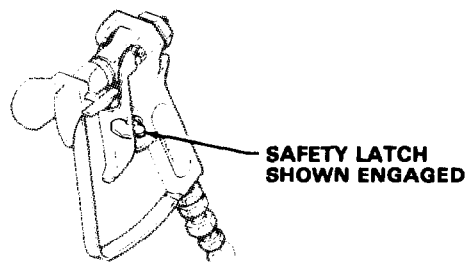

Reverse-A-Clean® III is a registered tradename of Graco Inc.

SETUP

Connect Hose and Gun

Remove the plastic plug from the pressure control outlet nipple. Connect the main fluid hose to the fluid outlet of the pressure control. See Fig 1. Connect the shorter hose to the main hose and then connect a spray gun to the other end of the hose. Don't use thread sealant, and don't install the spray tip yet!

WARNING

If you are supplying your own hoses and spray gun, be sure they are electrically grounded and rated for at least 3000 psi (210 bar) Working Pressure and that the gun has a tip guard. This is to reduce the risk of serious body injury caused by static sparking, fluid injection or overpressurizing and rupturing the equipment.

For two gun hookup, remove the plastic cap plug from the 1/4 npsm(f) nipple and connect an accessory hose and spray gun. See Fig 1.

CAUTION

To avoid damaging the pressure control, which may result in poor equipment performance and component damage, follow these precautions:

1. Always use at least 50 ft (15 m) of nylon spray hose.
2. Never use a wire braid hose as it is too rigid to act as a pulsation dampener.
3. Never install any shutoff device between the fluid outlet of the pressure control and the first 50 ft (15 m) of spray hose.
4. Always use the main fluid outlet for one-gun operation. Never plug this outlet.

Fill Packing Nut/Wet Cup

Pour throat seal liquid, supplied with the sprayer, into the packing nut/wet-cup until it is 1/3 full. Keep the wet-cup filled to help protect and prolong the life of the pump throat packings. See Fig 2.

Check Electrical Service

Be sure the electrical service is 120 V, 60 HzAc, 15 amp (minimum) and that the outlet you use is properly grounded.

Use an extension cord which has 3 wires of minimum 12 gauge size, rated for 15 Amps, and a maximum of 150 ft (45 m) long. Longer lengths may affect sprayer performance.

Plug In Sprayer

Be sure the ON/OFF switch is OFF. Plug the power supply cord into a grounded electrical outlet that is at least 20 ft (6 m) away from the spray area to reduce the chance of a spark igniting the spray vapors. See Fig 3.

Do not remove the third prong of the power supply cord plug, which is the grounding prong, and do not use an adapter.

Flush the Pump

Flush the pump to remove the lightweight oil which was left in to protect pump parts after factory testing. Refer to page 12 for WHEN and HOW to flush.

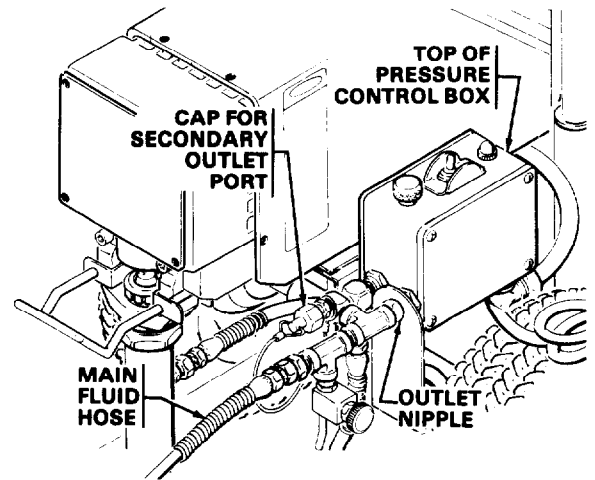

Fig 1

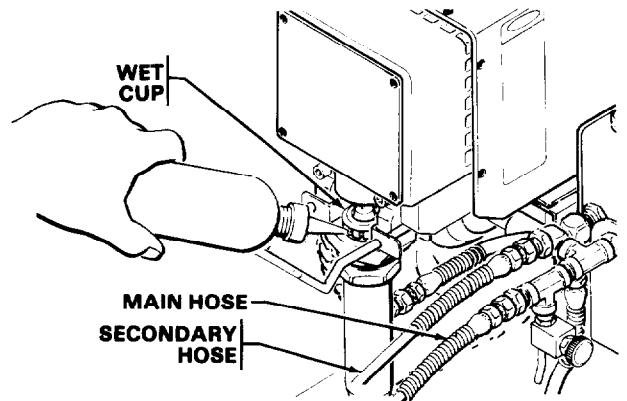

Fig 2

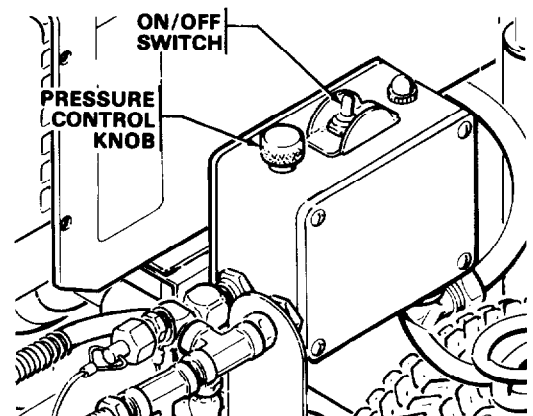

Fig 3

Prepare the Paint

Prepare the paint according to the manufacturer's recommendations. Remove any skin that may have formed, and stir the paint to dissolve hard pigments. Strain the paint through a fine nylon mesh bag (available at most paint dealers) to remove particles that could clog the spray tip. This is probably the most important step toward trouble-free spray painting.

OPERATION

WARNING

To reduce the risk of serious bodily injury, including fluid injection, splashing fluid or solvent in the eyes or on the skin, or injury from moving parts or electric shock, always follow this procedure whenever you shut off the sprayer, when checking or servicing any part of the spray system, when installing, cleaning or changing spray tips, and whenever you stop spraying.

1. Engage the gun safety latch.
2. Turn the ON/OFF switch to OFF.
3. Unplug the power supply cord.
4. Disengage the gun safety latch.
5. Hold a metal part of the gun firmly to the side of a grounded metal pail, and trigger the gun to relieve pressure.
6. Engage the gun safety latch.
7. Open the pressure relief valve, having a container ready to catch the drainage.
8. Leave the pressure relief valve open until you are ready to spray again.

If you suspect that the spray tip or hose is completely clogged, or that pressure has not been fully relieved after following the steps above, VERY SLOWLY loosen the tip guard retaining nut or hose end coupling and relieve pressure gradually, then loosen completely. Now clear the tip or hose.

Priming the Sprayer

Close the pressure relief valve. If a secondary hose and gun is not installed, be sure the cap is securely plugging the nipple. See Fig 2. Plug in the sprayer. Don't install the spray tip in the gun yet!

Place the suction tube into the paint container. Turn the pressure control knob all the way counterclockwise to the lowest pressure setting. See Fig 3. Disengage the gun safety latch.

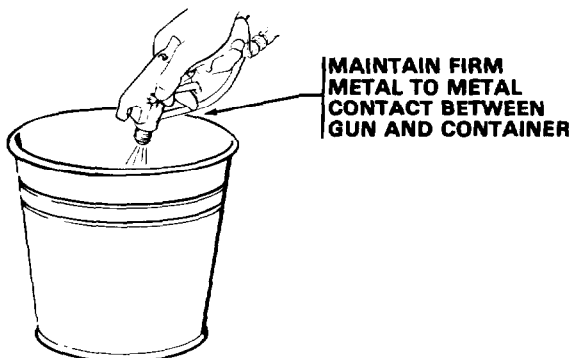

Fig 4

Hold a metal part of the gun firmly against the side of a grounded metal pail, and trigger the gun into the pail. Hold the trigger open, turn the sprayer ON, and slowly increase the pressure setting until the sprayer starts. Refer to Fig 4. This procedure reduces the risk of static electric discharge and splashing. Keep the gun triggered until all air is forced out of the system, and the paint flows freely from the gun. Release the trigger and engage the gun safety latch.

NOTE: If the paint is hard to prime, place a waste container under the pressure relief valve and open it. When fluid comes from the valve, close it. Then disengage the gun safety latch and follow the paragraph above.

Check all fluid connections for leaks. If any are found, follow the **Pressure Relief Procedure Warning**, above, before tightening connections.

Install the Spray Tip and Tip Guard

Be sure the gun safety latch is engaged. Install the tip and tip guard as instructed in the separate gun or tip instruction manual.

Adjusting the Spray Pattern

Increase the pressure adjusting knob setting just until spray from the gun is completely atomized. Refer to Fig 3. To avoid excessive overspray and fogging, and to decrease tip wear and extend the life of the sprayer, always use the lowest possible pressure needed to get the desired results.

If more coverage is needed, use a larger tip rather than increasing the pressure.

Test the spray pattern. To adjust the direction of the spray pattern, engage the gun safety latch and loosen the retaining nut. Position the tip so the groove is horizontal for a horizontal pattern or vertical for a vertical pattern. Then tighten the retaining nut.

Operating Tips

These suggestions will help prevent the motor from running too hot or operating intermittently.

- Decrease the pressure when using a small tip.
- Keep the sprayer in a shaded area when spraying outdoors.
- Turn off the sprayer and relieve pressure whenever you stop spraying.

Cleaning a Clogged Tip

WARNING

To reduce the risk of serious bodily injury from fluid injection, use extreme caution when clean or changing spray tips. **DO NOT** hold your hand, body, or a rag in front of the spray tip when cleaning or checking a clogged tip. Always point the gun toward the ground or into a pail when checking to see if the tip is clear.

Never wipe off buildup around the spray tip until pressure is fully relieved and the gun safety latch is engaged.

DO NOT try to "blow back" paint; this is **NOT** an air spray sprayer.

Follow the instructions given in your separate gun or spray tip instruction manual for cleaning a spray tip.

SHUTDOWN AND CARE

Check the packing nut/wet-cup daily. First follow the **Pressure Relief Procedure Warning** on page 10. Keep the wet-cup 1/3 full of throat seal liquid at all times to help prevent fluid buildup on the piston rod and premature packing wear. The packing nut should be tight enough to stop leakage, but no tighter. Over-tightening may cause binding and excessive packing wear. Use a screwdriver and light hammer to adjust the nut. See Fig 5.

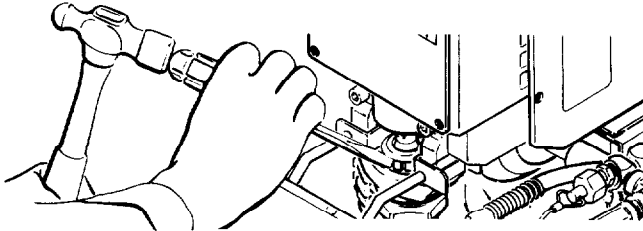

Fig 5

CAUTION

When adjusting the packing nut, be careful not to nick the cylinder threads which may be protruding above the bearing housing. Nicks to these threads may strip the threads in the bearing housing when the displacement pump is removed or installed.

Flush the sprayer at the end of each work day and fill it with mineral spirits to help prevent pump corrosion and freezing. See "Flushing Guidelines" on page 12.

CAUTION

Never leave water or any type of paint in the sprayer over night to: (1) prevent pump corrosion; (2) to prevent the fluid from freezing in the pump and pressure control which can cause loss of pressure, stalling or serious sprayer damage. Always use mineral spirits for the final flush. Relieve pressure. This leaves a protective coating of mineral spirits in the pump.

For very short shutoff periods, leave the suction tube in the paint, follow the **Pressure Relief Procedure Warning**, page 10, and clean the spray tip.

Coil the hose and hang it on the hose rack when storing the sprayer, even for overnight, to help protect the hose from kinking, abrasion, coupling damage, or other damage.

FLUSHING GUIDELINES

When to Flush

1. **New Sprayer.** Your new Ultimate Nova™ 1000 Sprayer was factory tested in lightweight oil which was left in to protect pump parts.
Before using water-base paint, flush with mineral spirits, followed by soapy water, and then a clean water flush.
Before using oil-base paint, flush with mineral spirits only.
2. **Changing Colors.** Flush with a compatible solvent such as mineral spirits or water.
3. **Changing from water-base to oil-base paint.** Flush with soapy water, then mineral spirits.
4. **Changing from oil-base to water-base paint.** Flush with mineral spirits, followed by soapy water, then a clean water flush.
5. **Storage.**
Water-base paint: flush with water, then mineral spirits and leave the pump, hose and gun filled with mineral spirits. Shut off and unplug the sprayer, open the pressure relief valve to relieve pressure and leave open.
Oil-base paint: flush with mineral spirits. Shut off and unplug the sprayer, open the pressure relief valve to relieve pressure and leave open.
6. **Startup after storage.**
Before using water-base paint, flush out mineral spirits with soapy water and then a clean water flush.
When using oil-base paint, flush out the mineral spirits with the fluid to be sprayed and the sprayer is ready to use.

How to Flush

1. Engage the gun safety latch, turn the ON/OFF switch to OFF, release the gun safety, trigger the gun to relieve pressure, engage the gun safety and open the pressure relief valve.
2. Pour one-half gallon (2 liters) of compatible solvent into a bare metal pail. Put the suction tube in the pail.
3. Close the pressure relief valve.
4. Remove the spray tip from the gun.
5. Point the spray gun into a metal waste container and with a metal part of the gun firmly touching the metal container, squeeze the gun trigger. See Fig 6. **This procedure helps reduce the risk of static sparking and splashing.** With the gun triggered, turn the ON/OFF switch to ON and slowly turn the pressure adjusting knob clockwise **just until** the sprayer starts. Keep the gun triggered until clean solvent comes from the nozzle. Release the trigger and engage the gun safety latch.
6. Check all fluid connections for leaks. If any leak, first follow the **Pressure Relief Procedure Warning** on page 10. Now tighten the connections, start the sprayer, and recheck the connections for leaks.
7. Remove the suction tube from the pail. Disengage the gun safety and trigger the gun to force solvent from the hose. **Do not let the pump run dry for more than 30 seconds to avoid damaging the pump packings!** Then turn ON/OFF switch to OFF and engage the gun safety.

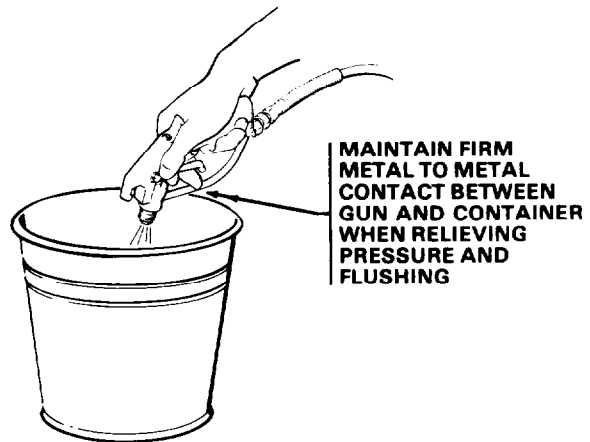

Fig 6

8. Unplug the power supply cord. Open the pressure relief valve and leave open until you are ready to use the sprayer again.
9. If you flushed with mineral spirits and are going to use a water-base paint, flush with soapy water followed by a clean water flush. Then repeat Step 1.

WARNING

Pressure Relief Procedure

To reduce the risk of serious bodily injury, including fluid injection, splashing fluid in the eyes or on the skin, or injury from moving parts or electric shock, always follow this procedure whenever you shut off the sprayer, when checking or servicing any part of the spray system, when installing, cleaning or changing spray tips, and whenever you stop spraying.

1. Engage the gun safety latch.
2. Turn the ON/OFF switch to OFF.
3. Unplug the power supply cord.
4. Disengage the gun safety latch.
5. Hold a metal part of the gun firmly to the side of a metal pail, and trigger the gun to relieve pressure.
6. Engage the gun safety latch.
7. Open the drain valve.
8. Leave the drain valve open until you are ready to spray again.

If you suspect that the spray tip or hose is completely clogged, or that pressure has not been fully relieved after following the steps above, VERY SLOWLY loosen the tip guard retaining nut or hose end coupling and relieve pressure gradually, then loosen completely. Now clear the tip or hose.

TYPE OF PROBLEM	WHAT TO CHECK If check is OK, go to next check	WHAT TO DO When check is not OK refer to this column
<p>MOTOR WON'T OPERATE</p> <p>Basic Fluid Pressure Problems</p>	<ol style="list-style-type: none"> 1. Check the pressure control knob setting. The motor will not run if it is at the minimum setting (fully counterclockwise). 2. Check for a clogged spray tip. Refer to your separate gun or tip instruction manual. 	<ol style="list-style-type: none"> 1. Slowly increase the pressure setting to see if the motor starts. 2. Relieve pressure, refer to your separate gun or tip instruction manual for tip cleaning.
<p>Basic Mechanical Problems</p>	<ol style="list-style-type: none"> 1. Check for frozen or hardened fluid in the pump (39) and/or pressure control bourdon tube. Using a screwdriver, carefully try to rotate fan at back of motor by hand. See page 22. 2. Check displacement pump connecting rod pin (20). It must be completely pushed into connecting rod (29) and spring retainer (35) should be firmly in groove of connecting rod. See page 28. 3. Check for motor damage. Remove drive housing assembly (18). Try to rotate fan by hand. See page 29. 	<ol style="list-style-type: none"> 1. Thaw¹. Plug in sprayer and turn on. Slowly increase pressure setting to see if motor starts. If it doesn't, replace the displacement pump packings (see manual 307-793) and/or replace the bare pressure control box (301)². See page 26. 2. Push pin into place and secure with the spring retainer. 2. Replace motor (1) if fan won't turn.
<p>Basic Electrical Problems</p>	<ol style="list-style-type: none"> 1. Check sprayer circuit breaker (309) button to be sure it has not popped up. 2. Check electrical supply with volt meter. Meter should read 105 to 125 VAC. 3. Check extension cord for visible damage. Use a volt meter or test lamp at extension cord outlet to check. 4. Check sprayer power supply cord (311) for visible damage such as broken insulation or wires. 5. Check motor brush leads, terminals and brush length. Brush length should be 1/2" minimum. See page 22. 	<ol style="list-style-type: none"> 1. Depress circuit breaker button to reset. If circuit breaker continues to open, see "Electrical Short", page 18. 2. Reset building circuit breaker; replace building fuse. Try another electrical outlet. 3. Replace extension cord. 4. Replace power supply cord. See page 23. 5. Tighten terminal screws; replace brushes. See page 22.

¹Thaw the sprayer if water or water-based fluid has frozen in it, due to exposure to low temperatures, by placing it in a warm area. Do not try to start the sprayer until it has thawed completely. If the bourdon tube was not damaged by the freezing, the pump should operate. If fluid hardened (dried) in the sprayer, the pump packings and/or bare pressure control must be replaced. See page 26 or manual 307-793.

²When replacing the bare pressure control box (item 301), remove the circuit breaker, ON/OFF switch, bridge, circuit board and electrical hardware and reinstall these parts in the bare box.

TYPE OF PROBLEM	WHAT TO CHECK If check is OK, to to next check	WHAT TO DO When check is not OK refer to this column
<p>MOTOR WON'T OPERATE</p> <p>Diagnosing circuit board indicator lamps. The normal condition is red lamp on, clear lamp on when board is telling pump to run.</p> <p>Follow Pressure Relief Procedure. Remove gun from hose. Remove pressure control cover and check for faulty condition of circuit board lamps.</p> <p>Condition A both lamps on; pump won't operate and motor is not running</p>	<ol style="list-style-type: none"> 1. Check leads from bridge (308) to motor to be sure they are securely fastened and properly mated. 2. Check G1 and G2 connections between circuit board (23) and bridge (308) for damage or loose terminals. 3. Check for loose motor brush lead connections and terminals. See page 22. 4. Check brush length which should be 1/2" minimum. See page 22. NOTE: Brushes do not wear at the same rate on both sides of motor. 5. Check for broken or misaligned motor brush springs. Rolled portion of spring must rest squarely on top of brush. See page 22. 6. Check motor brushes for binding in brush holders. See page 22. 7. Check motor armature commutator for burn spots, gouges and extreme roughness. Remove motor cover and brush inspection plates to check. See page 22. 8. Check motor armature for shorts using armature tester (growler) or perform spin test. See page 19 9. Check bridge (308) by substituting with a good bridge or performing bridge test. See page 20. CAUTION: Do not perform this check until armature is determined to be good. A bad armature will immediately burn out a good bridge. 	<ol style="list-style-type: none"> 1. Replace any loose terminals and crimp to leads. Be sure male terminal blades are straight and firmly connected to mating part. 2. Clean circuit board male terminals. Replace loose or damaged terminals. Securely reconnect leads. 3. Tighten terminal screws. Replace brushes if leads are damaged. See page 22. 4. Replace brushes. See page 22. 5. Replace spring if broken. Realign spring with brush. See page 22. 6. Clean brush holders. Remove carbon with small cleaning brush. Align brush lead with slot in brush holder to assure free vertical brush movement. 7. Remove motor and have motor shop resurface commutator if possible. See page 30. 8. Replace motor. See page 30. 9. Replace bridge. See page 24.
<p>Condition B Both lamps off</p>	<ol style="list-style-type: none"> 1. Check circuit breaker (309) button to be sure it has not popped up. 2. Check sprayer power supply cord (311). Disconnect TP6 female and TP1 female and connect volt meter to these leads. Plug in sprayer. Meter should read 105 to 125 VAC. Unplug sprayer. Reconnect TP1. 3. Check ON/OFF switch (303). Disconnect TP2 and connect volt meter to TP6 female and TP2 male. Plug in sprayer and turn on. Meter should read 105 to 125 VAC. Turn off and unplug sprayer. Reconnect TP2. 4. Check jumper wire (306). Disconnect TP3 and connect volt meter to TP6 female and TP3 female. Plug in sprayer and turn on. Meter should read 105 to 125 VAC. Turn off and unplug sprayer. Reconnect TP3. 5. Check circuit breaker (309). Connect volt meter to TP6 female and TP4. Plug in sprayer and turn on. Meter should read 105 to 125 VAC. Turn off and unplug sprayer. 	<ol style="list-style-type: none"> 1. Depress circuit breaker button to reset. If circuit breaker continues to open, see "Electrical Short", 18. 2. Replace power supply cord. See page 23. 3. Replace ON/OFF switch. See page 23. 4. Replace jumper wire. See page 24. 5. Replace circuit breaker. See page 24.

Troubleshooting continued on next page.

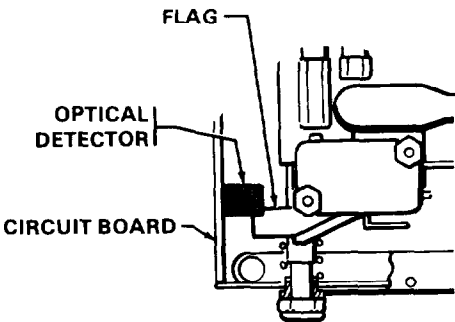
TYPE OF PROBLEM	WHAT TO CHECK If check is OK, go to next check	WHAT TO DO When check is not OK refer to this column
Condition B (Continued)	<ol style="list-style-type: none"> 6. Check motor thermal cutout switch. Connect volt meter to TP6 female and TP9 female. Plug in and turn on sprayer. Meter should read 105 to 125 VAC. Turn off and unplug sprayer. 7. Check microswitch (301). Reconnect TP6 connectors. Connect volt meter to TP15 male and TP4. Meter should read 50-125 VAC. 8. Visually inspect microswitch (302) button. Adjustment stud (Q) should not depress the microswitch button when fluid pressure is zero. Manually check by depressing button with small screwdriver; an audible click indicates microswitch is in normal position. 9. Check microswitch (302) continuity with ohm meter. <i>Be sure sprayer is unplugged!</i> Meter should read zero ohms with no fluid pressure in the sprayer. 10. Check all terminals for damage or loose fit. Reconnect TP6 connectors. 11. Check circuit board (23) by substituting with a good board. See page 25. 	<ol style="list-style-type: none"> 6. Allow motor to cool. Correct cause of overheating. If switch remains open after motor cools, check continuity between TP9 female and TP10 with ohmmeter. If open, replace motor. 7. Clean microswitch male terminals. Replace loose or damaged terminals. Securely reconnect leads. 8. Microswitch is faulty. Return sprayer for repair. 9. Microswitch is faulty. Return sprayer for repair. 10. Replace damaged terminals and reconnect securely. 11. Replace circuit board. See page 25.
Condition C Red lamp on, clear lamp off <i>Unplug sprayer!</i>	<ol style="list-style-type: none"> 1. Check circuit board (23) by removing from box <i>without disconnecting wires</i>; see page 25 for removal procedure. WARNING: Removing the circuit board while still wired over-rides the optical detector which could cause the sprayer to over-pressurize, if the microswitch does not function properly. Turn the sprayer on <i>ONLY</i> long enough to check lamp condition, then shut off immediately. WARNING: To reduce the risk of electric shock, handle board by edges only! Do not allow any metal objects to come in contact with the board! Plug in and turn on sprayer. Clear lamp should be on now — removing the circuit board over-rides the optical detector. Turn off and unplug sprayer. 2. Check bourdon tube flag and detector position. Reinstall circuit board (see page 25). Turn pressure setting to maximum; flag should extend less than half way into optical detector slot from the bottom. <div style="text-align: center;">  </div> <p style="text-align: center;">VIEW OF OPTICAL DETECTOR AND FLAG</p>	<ol style="list-style-type: none"> 1. Replace circuit board. See page 25. 2. Calibrate pressure control to see if that corrects problem. See page 27. If not, replace bare pressure control box (301)*. See page 26.

*When replacing the bare pressure control box (301), remove the circuit breaker, bridge, circuit board and electrical hardware and reinstall in the new bare box.

TYPE OF PROBLEM	WHAT TO CHECK If check is OK, go to next check	WHAT TO DO When check is not OK refer to this column
<p>LOW OUTPUT</p>	<ol style="list-style-type: none"> 1. Check for worn spray tip. 2. Check to see that pump does not continue to stroke when gun trigger is released. Plug in and turn on sprayer. Prime with fluid. Trigger gun momentarily, then release and engage safety latch. Relieve pressure, turn off and unplug sprayer. 3. Check electrical supply with volt meter. Meter should read 105 to 125 VAC. 4. Check extension cord size and length; must be at least 12 gauge wire and no longer than 150 ft (15.2 m). 5. Check G1 and G2 leads from bridge (308) to circuit board (23) for damage or loose wires or connectors. Refer to page 25. 6. Check stall pressure. Refer to Calibration Procedure on page 27. 7. Check bridge (308) + and - leads and terminals to motor. Inspect wiring insulation and terminals for signs of overheating. See page 24. 8. Check for loose motor brush leads and terminals. See page 22. 9. Check for worn motor brushes which should be 1/2" minimum. See page 22. 10. Check for broken and misaligned motor brush springs. Rolled portion of spring must rest squarely on top of brush. 11. Check motor brushes for binding in brush holders. See page 22. 12. Check circuit board (23) by substituting with a good circuit board. See page 22. 13. Check motor armature for shorts by using an armature tester (growler) or perform spin test. See page 19. 14. Check bridge (308) by substituting with a good bridge or by performing the bridge test. See page 24 or 20. CAUTION: Do not perform this check until armature is determined to be good. A bad armature will immediately burn out a good bridge. 	<ol style="list-style-type: none"> 1. Follow Pressure Relief Procedure then replace tip. See your separate gun or tip manual. 2. Service pump. See manual 307-793. 3. Reset building circuit breaker; replace building fuse. Repair electrical outlet or try another outlet. 4. Replace with a correct, grounded extension cord. 5. Clean circuit board male terminals. Replace loose or defective lead terminals. Securely reconnect lead terminals to board. 6. Calibrate pressure control. See page 27. 7. Be sure male terminal blades are centered and firmly connected to female terminals. Replace any loose terminal or damaged wiring. Securely reconnect wires to bridge. 8. Tighten terminal screws. Replace brushes if leads are damaged. See page 25. 9. Replace brushes. See page 22. 10. Replace spring if broken. Realign spring with brush. See page 22. 11. Clean brush holders, remove carbon dust with small cleaning brush. Align brush lead with slot in brush holder to assure free vertical brush movement. 12. Replace circuit board. See page 22. 13. Replace motor. See page 31. 14. Replace bridge. See page 24.
<p>NO OUTPUT</p> <p>Motor runs and pump strokes</p>	<ol style="list-style-type: none"> 1. Check fluid supply. 2. Check for clogged intake strainer. See page 29. 3. Check for loose suction tube or fittings. See page 29. 	<ol style="list-style-type: none"> 1. Refill and reprime pump. 2. Remove and clean, then reinstall. 3. Tighten; use thread sealant or sealing tape on threads if necessary.

Troubleshooting continued on next page.

TYPE OF PROBLEM	WHAT TO CHECK If check is OK, go to next check!	WHAT TO DO When check is not OK refer to this column
NO OUTPUT (Continued) Motor runs but pump does not stroke	<ol style="list-style-type: none"> 4. Check to see if intake valve ball and piston ball are seating properly. See manual 307-793. 5. Check for leaking around throat packing nut which may indicate worn or damaged packings. See manual 307-793. 1. Check displacement pump connecting rod pin. See page 28. 2. Check connecting rod assembly for damage. See page 28. 3. Be sure crank in drive housing rotates; plug in sprayer and turn on momentarily to check. Turn off and unplug sprayer. See page 29. 	<ol style="list-style-type: none"> 4. Remove intake valve and clean. Check balls and seats for nicks; replace if necessary. See manual 307-793. 5. Replace packings. See manual 307-793. Also check piston valve seat for hardened fluid or nicks and replace if necessary. 1. Replace pin if missing. Be sure retainer spring is fully in groove all around connecting rod. See 28. 2. Replace connecting rod assembly. See page 28. 3. Check drive housing assembly for damage and replace if necessary. See page 29.
EXCESSIVE PRESSURE FLUCTUATIONS Spray pattern variations.	<ol style="list-style-type: none"> 1. Be sure both G1 and G2 leads from bridge (308) to circuit board (23) are firmly connected. See page 25. 2. Check stall pressure. Refer to Calibration procedure on page 27. 3. Check bourdon tube flag and detector position. Turn pressure setting to maximum; flag should not drag or bind in optical detector slot of circuit board. <div data-bbox="581 1038 873 1212" style="text-align: center;"> <p style="text-align: center;">VIEW OF OPTICAL DETECTOR AND FLAG</p> </div> <ol style="list-style-type: none"> 4. Check circuit board (23) by substituting with a good board. See page 25. 5. Check LOW OUTPUT section on page 16. 	<ol style="list-style-type: none"> 1. Reconnect securely. See page 24 and 25. 2. Calibrate pressure control See page 27. 3. Carefully bend flag into alignment with detector slot to see if that corrects problem. If not, replace bare pressure control assembly (301)². Calibrate pressure control after reassembly. 4. Replace circuit board. See page 25.
MOTOR IS HOT & RUNS INTERMITTENTLY	<ol style="list-style-type: none"> 1. Check to see if sprayer has been operating at high pressure with small tips, which causes low motor RPM and results in excessive heat build up. 2. Check to see if ambient temperature where sprayer is located is more than 90°F (32°C) or if sprayer is located in direct sun. 3. Check to see if sprayer has been left in a stalled condition (sprayer turned on, pressurized, but not operating) for long periods of time. 	<ol style="list-style-type: none"> 1. Decrease pressure setting or increase tip size. 2. Move sprayer to shaded, cooler area if possible. 3. Turn off sprayer whenever you stop spraying for a while and relieve fluid pressure.

²When replacing the bare pressure control box (301), remove the circuit board, bridge, circuit board, and electrical hardware and reinstall in the new bare box.

TYPE OF PROBLEM	WHAT TO CHECK If check is OK, go to next check	WHAT TO DO When check is not OK refer to this column
<p>ELECTRICAL SHORT</p> <p>Building circuit breaker opens as soon as sprayer switch is turned on.</p> <p>CAUTION Any short in any part of the motor power circuit, which is connected to the output side of the bridge, will cause the bridge to burn out immediately. Correctly diagnose and repair all shorts before checking and replacing bridge.</p>	<ol style="list-style-type: none"> 1. Check all electrical wiring for damaged insulation, and all terminals for loose fit or damage. Be sure to check wires between pressure control and motor which are encased in conduit (22). See page 29. 2. Check for missing inspection plate gasket (see page 22), bent terminal forks or other metal to metal contact points which could cause a short. 3. Check motor armature for shorts by using an armature tester (growler) or perform spin test. See page 19. Inspect windings for burns. 4. Check bridge (308) by substituting with a good bridge or by performing bridge test. See page 20. <p>CAUTION: Do not perform this check until armature is determined to be good. A bad armature will immediately burn out a good bridge.</p>	<ol style="list-style-type: none"> 1. Repair or replace any damaged wiring or terminals. Securely reconnect all wires. 2. Correct faulty conditions. 3. Replace motor. See page 30. 4. Replace bridge. See page 24.
<p>Building circuit breaker opens as soon as sprayer is plugged into outlet and sprayer is NOT turned on.</p>	<ol style="list-style-type: none"> 1. Check 'Basic Electrical Problems' on page 14. 2. Check ON/OFF switch (303) See page 23. <i>Be sure the sprayer is unplugged!</i> Disconnect wires from switch and check switch with ohm meter. The ohm meter should read infinity with the ON/OFF switch OFF, and zero with the switch ON. <p>CAUTION: A short in the motor circuit will burn the bridge out immediately, which in turn usually causes the ON/OFF switch to fail in the closed mode.</p>	<ol style="list-style-type: none"> 2. Replace ON/OFF switch. See page 23.
<p>Sprayer circuit breaker opens after sprayer operates for only 5 to 10 minutes.</p>	<ol style="list-style-type: none"> 1. Check electrical supply with volt meter. Meter should read 105 to 125 VAC. 2. Check tightness of pump packing nut. Overtightening nut tightens packings on rod, restricts pump action, and damages packings. See page 28. 3. Check stall pressure. Remove the elbow (88) and secondary ball valve (30) from the tee (124) at the pressure control outlet. Install a 5000 psi (350 bar) fluid-filled pressure gauge in the tee (124). See page 27. Plug in and turn on sprayer. Slowly increase pressure setting to maximum. Pump should stall at 2800-3000 psi (196-210 bar). Turn off and unplug sprayer. 4. After determining that there is no short in system, reset circuit breaker button. 	<ol style="list-style-type: none"> 1. If voltage is too high, do not operate sprayer until corrected. 2. Loosen packing nut. Check for leaking around throat. Replace pump packings, if necessary. See manual 307-793. <p>Calibrate pressure control. See page 27.</p> <ol style="list-style-type: none"> 4. If circuit breaker continues to open (button pops up), replace the circuit breaker. See page 24.

SPIN TEST

WARNING

Before doing this procedure, follow the **Pressure Relief Procedure Warning** on page 13 to reduce the risk of an injection injury, injury from moving parts, or electric shock.

For checking armature, motor winding and brush electrical continuity.

Setup

Remove the drive housing from the sprayer as described in "Drive Housing Replacement", Steps 1-6, page 29.

Remove the pressure control cover and screws, the motor cover, the fan cover (F), and the inspection covers (J). See Fig 7.

Disconnect the two leads from the motor to the bridge (308). See Fig 8 and 9.

Armature Short Circuit Test

Quickly turn the motor fan by hand. *If there are no shorts*, the motor will coast two or three revolutions before coming to a complete stop.

If the motor does not spin freely and resists rotation, the armature is shorted and the motor must be replaced. See page 30.

Armature, Brushes, and Motor Wiring Open Circuit Test (Continuity)

Connect the two black motor leads together with a test lead.

Turn the motor fan by hand at about two revolutions per second.

If there is uneven or no turning resistance, check the following: a) broken brush springs; b) broken brush leads; c) loose brush terminal screws; d) worn brushes; e) broken motor leads; f) loose motor lead terminals. Repair parts as needed. See page 22.

If there is still uneven or no turning resistance, replace the motor. See page 30.

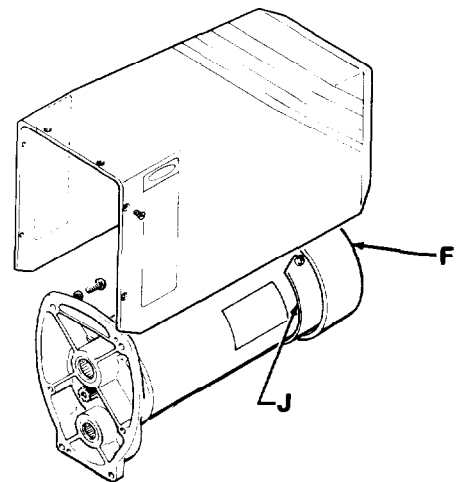

Fig 7

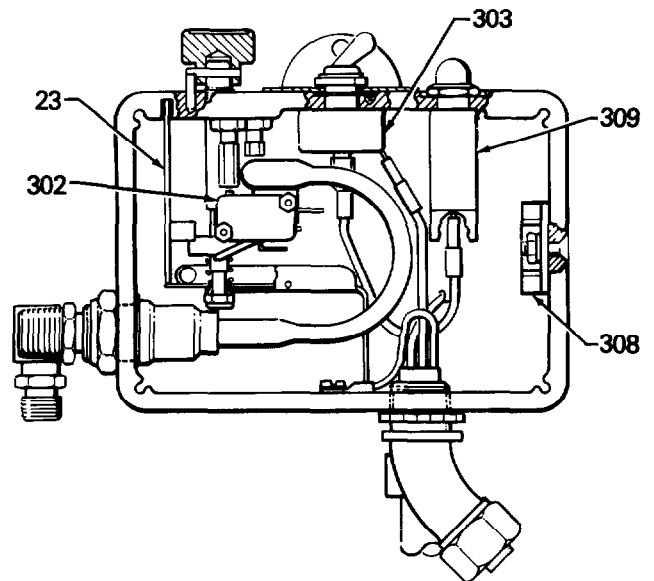

Fig 8

BRIDGE TEST

Remove the bridge from the pressure control box and perform this test to determine if the bridge is functional. Use a continuity tester, such as multi-meter set on the X1 ohms scale (Ω).

Eight individual checks, or tests, must be performed. If the bridge fails even one test, it must be replaced.

Fig 9 shows the position of the wires on the bridge. Using the chart at the right, connect the meter wires as indicated by the black dots for each test, then check the continuity.

In Tests 1, 2 and 3, there should be NO continuity.

In Tests 4,5 and 6, connect the + and - meter wires as indicated, check continuity, then switch the meter wire connections and check continuity again. You should get NO continuity one way, and YES continuity the other way.

In Tests 7 and 8, connect the meter wires as indicated by the black dots. Touch the indicated "G" wire to one meter wire, and then to the other. You should get NO continuity one way, and YES continuity the other way.

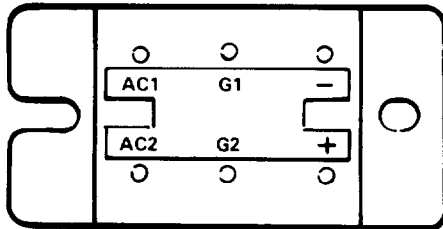

		BRIDGE WIRES						
		G2	G1	-	+	AC1	AC2	
CONTINUITY	NO					•	•	TEST 1
	NO				•		•	TEST 2
	NO				•	•		TEST 3
	YES			•	•			TEST 4
	NO			•	•			
	YES			•	•			TEST 5
	NO			•	•			
	YES			•	•			TEST 6
NO			•	•				
YES			♂	-----	-----	-----	♂	TEST 7
NO			♂	-----	-----	-----	♂	
YES			♂	-----	-----	-----	♂	TEST 8
NO			♂	-----	-----	-----	♂	

Fig 9

REPAIR SECTION INDEX

Procedure	Page
General Repair Notes.....	21
Motor Brush Replacement.....	22
Power Supply Cord Replacement.....	23
ON/OFF Switch Replacement.....	23
Bridge Rectifier Replacement.....	24
Circuit Breaker Replacement.....	24
Circuit Board Replacement.....	25
Pressure Control Replacement.....	26
Stall Pressure Calibration.....	27
Bearing Housing & Connecting Rod Replacement.....	28
Drive Housing Replacement.....	29
Motor Replacement.....	30
Parts Drawing & List, Sprayer.....	32
Parts Drawing & List, Pressure Control.....	34
How To Order Replacement Parts.....	33

NOTE: See separate manual 307-793 for displacement pump repair.

The following tools are needed when repairing this sprayer.

Phillips screwdriver
 Small flatblade screwdriver
 Needle nose pliers
 Plastic mallet
 Adjustable wrench
 2" adjustable, open-end wrench
 Torque wrench
 1/4" hex key wrench
 3/16" hex key wrench
 5/8" socket wrench
 3/8" open end wrench
 1/2" open end wrench
 3/4" open end wrench
 7/8" open end wrench
 High quality motor oil
 Bearing grease

For calibration procedure only:

3/8" ignition wrench
 0.015" spray tip
 High pressure, oil-filled test gauge, Part No. 820-455
 5 gallon pail
 Clean water
 Mineral spirits
 NEW 3000 psi (210 bar) high pressure spray hose

GENERAL REPAIR NOTES

Before repairing any part of the sprayer, read the following general repair notes and the repair procedure. Be sure you have the necessary tools and parts available.

- When disconnecting wires in the pressure control assembly, use needle nose pliers to separate mating connectors.

When reconnecting the wires, be sure the flat blade of the insulated male connector is centered in the wrap-around blade of the female connector when the connection is made.

CAUTION

To reduce the risk of a pressure control malfunction, be sure to properly mate connectors, and *never* pull on a wire to disconnect it. Pulling on a wire could loosen the connector from the wire.

- Route wires in the pressure control assembly carefully through the legs of the U-shaped bourdon tube, where appropriate, to avoid interfering with the bourdon tube which moves as the pressure setting changes and to avoid pinching the wires between the pressure control box and cover.

CAUTION

Improper wire routing can result in poor sprayer performance or damage to the pressure control.

- Keep all screws, nuts, washers, gaskets, and electrical fittings removed during repair procedures. These parts are not normally provided with replacement assemblies.

- Test your repair before regular operation of the sprayer to be sure the problem is corrected.

If the sprayer does not operate properly, review the repair procedure again to verify that everything was done correctly. If necessary, refer to the *Troubleshooting Guide* to help identify other possible problems and solutions.

WARNING

To avoid serious bodily injury, including electric shock, DO NOT touch any moving parts or electrical parts with your fingers or a tool while inspecting the repair.

Shut off the sprayer and unplug it as soon as you complete the inspection.

Reinstall all covers, gaskets, screws and washers before operating the sprayer.

CAUTION

Do not run the sprayer dry for more than 30 seconds to avoid damaging the pump packings.

- Reinstall the motor cover before regular operation of the sprayer and replace it if it is damaged. The cover directs cooling air around the motor to help prevent overheating. It can also help prevent burns, fire or explosion; see the **WARNING**, below.

WARNING

During operation, the motor becomes very hot and could burn your skin if touched. Flammable fluids and materials spilled on the hot, bare motor could cause a fire or explosion. Always have the motor cover in place during regular operation to reduce the risk of burns, fire or explosion.

MOTOR BRUSH REPLACEMENT (See Fig 10 and 11)

NOTE: Replace the brushes when they have worn to no less than 1/2" minimum. See Fig 11. Note that the brushes wear differently on each side of the motor. Brush Repair Kit 820-521 is available.

WARNING

Before doing this procedure, follow the **Pressure Relief Procedure Warning** on page 13 to reduce the risk of injection injury, injury from moving parts or electric shock. Unplug the sprayer!

1. Remove the motor cover (14). See Fig 10.
2. Remove the screws (H), inspection covers (J) and gaskets (K) on each side of the motor. See Fig 10.
3. Push down and then in on the spring clip, and then pull the clip out of the brush holder. Refer to STEP 3, Fig 11. Keep the spring clip.
4. Loosen the brush terminal screw and remove the lead.
5. Remove and discard the brush.
6. Inspect the commutator for excessive pitting, burning or gouging.

NOTE: A black color on the commutator is normal.

Have the commutator resurfaced by a qualified motor repair shop if the brushes seem to be wearing too fast.

7. Place a new brush in the holder so the lead is at the top of the holder. Place the brush lead terminal on the terminal screw so the terminal is parallel with the brush holder. Tighten the terminal screw. See STEP 1, Fig 11.
8. With the spring roll touching the brush, push the forked end of the spring clip into the brush holder. See STEP 2, Fig 11. When the fork passes through the end of the holder, push the clip up or down until the fork hooks at the end of the holder. See STEP 3, Fig 11.
9. Position the brush lead as in STEP 3, Fig 11. Be sure the brush lead does not touch any part of the armature or motor housing.
10. Test the brushes:
 - a. With the ON/OFF switch OFF, turn the pressure control knob all the way counterclockwise to minimum pressure. Plug in the sprayer.
 - b. Turn the ON/OFF switch ON and slowly increase the pressure until the motor comes up to full speed.
 - c. Inspect the brush and commutator contact area for excessive arcing. Arcs should not "trail" or circle around the commutator surface.

WARNING

Do not touch the brushes, leads, springs or brush holders while the sprayer is plugged in to avoid electric shock and possible serious bodily injury.

CAUTION

Do not run the sprayer dry for more than 30 seconds while checking the brushes to avoid damaging the displacement pump.

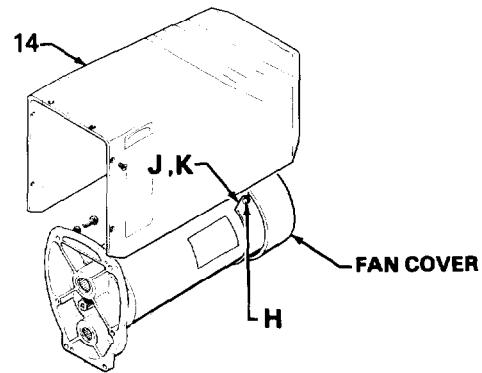

Fig 10

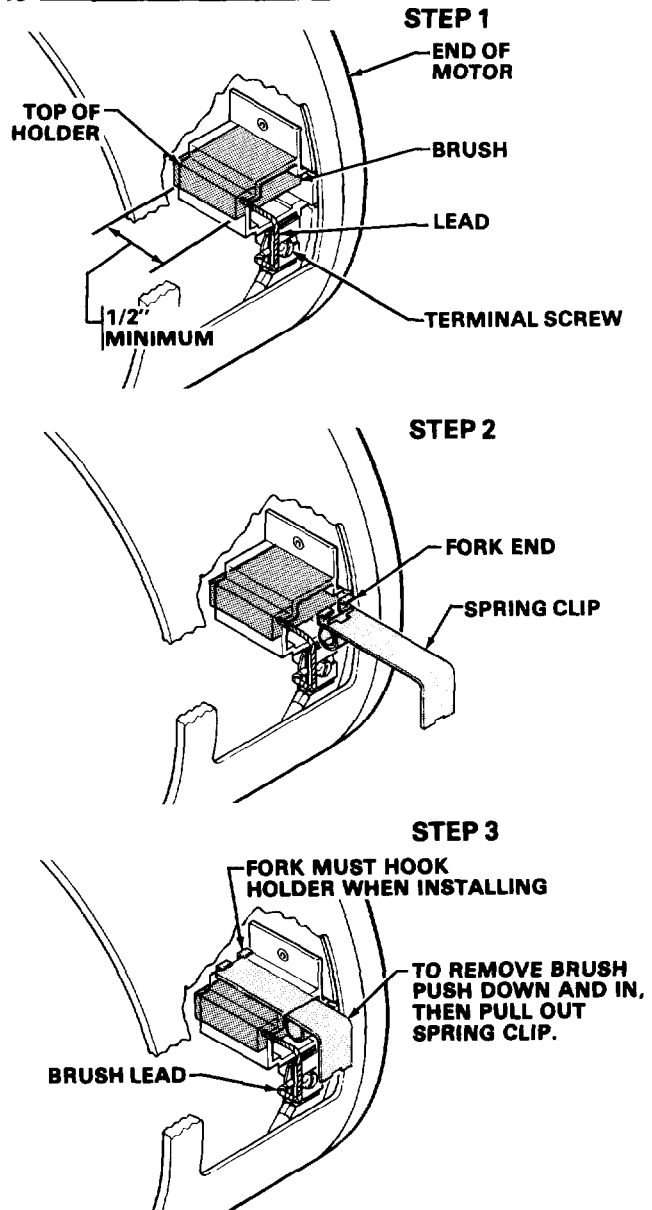

Fig 11

11. Reinstall the brush inspection covers, gaskets, and screws. Reinstall the motor cover and screws.

POWER SUPPLY CORD REPLACEMENT (See Fig 12)

WARNING

Before doing this procedure, follow the **Pressure Relief Procedure Warning** on page 13 to reduce the risk of an injection injury, injury from moving parts, or electric shock. Unplug the sprayer!

1. Remove the pressure control cover and screws.
2. Disconnect the power supply cord lead from the ON/OFF switch (303), the white wire going to the bridge (308), and the green wire to the grounding screw (343) and lockwasher (327).
3. Loosen the strain relief bushing (328). Remove the power supply cord (311).
4. Install the new cord in the reverse order of disassembly.
5. Reinstall the cover and screws.

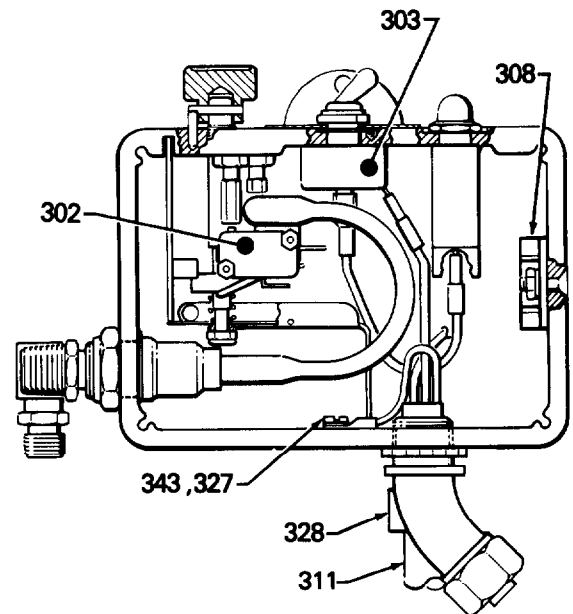

Fig 12

ON/OFF SWITCH REPLACEMENT (See Fig 12 and 13)

WARNING

Before doing this procedure, follow the **Pressure Relief Procedure Warning** on page 13 to reduce the risk of an injection injury, injury from moving parts, or electric shock. Unplug the sprayer!

1. Remove the pressure control cover and screws.
2. Use a needle nose pliers to disconnect the upper terminal wire from the microswitch (302) for ease in removing the ON/OFF switch (303). Refer to Fig 12.
3. Use the pliers to disconnect the two black wires from the ON/OFF switch (303). Refer to Fig 12.
4. Use a 5/8" socket wrench to loosen and remove the nut and rubber boot (304) from the top of the pressure control box. Remove the switch guard (305). See Fig 13.
5. Remove the ON/OFF switch.
6. Install the new switch so the internal tab of the anti-rotation ring (W) engages with the vertical groove in the threads of the switch, and the external tab engages with the blind hole (D) of the pressure control box. See Fig 13.
7. Install the switch guard (305), aligning the internal tab with the groove in the threads. See Fig 13.
8. Install the nut and rubber boot (304) and tighten. See Fig 13.
9. Reconnect the wires to the ON/OFF switch (303) and reconnect the wire to the microswitch (302). Refer to Fig 12.
10. Reinstall the pressure control cover and screws.

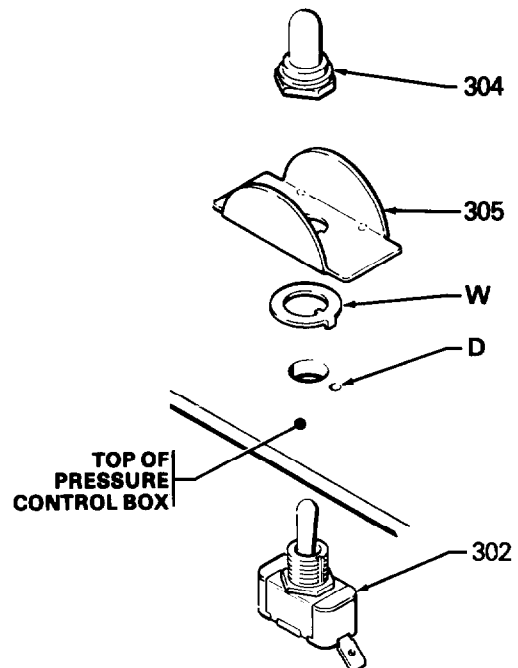

Fig 13

BRIDGE RECTIFIER REPLACEMENT (Refer to Fig 14)

WARNING

Before doing this procedure, follow the **Pressure Relief Procedure Warning** on page 13 to reduce the risk of an injection injury, injury from moving parts or electric shock. Unplug the sprayer!

CAUTION

The most common cause of a bridge failure is a faulty motor. Check the motor before replacing the bridge to prevent damaging the new bridge.

1. Remove the pressure control cover and screws.
2. Disconnect all wires from the bridge (308) at the appropriate terminals.
3. Outside the pressure control box on the right side are two screws (331). *Loosen*, but don't remove the screw near the back of the control box. Then loosen and remove the front screw. Slide the bridge out.
4. Slide the new bridge (308) into the box being sure the lockwasher (333) on the rear screw (331) is *IN FRONT* of the bridge. Refer to the Detail in Fig 14.
5. Install the front screw, lockwasher and nut (332).

CAUTION

The lockwashers (333) must be in front of the bridge to avoid overheating which will result in bridge failure. Refer to the Detail in Fig 14.

6. Make sure the bridge is flush with the side of the box and tighten the screws securely.
7. Connect all wires. Carefully route the wires.

CAUTION

Be sure the flat blade of the insulated male connector is centered in the wrap-around blade of the female connector when the connections are made. Improper connections may cause the sprayer to malfunction.

Route all wires carefully to avoid interference with the movement of the bourdon tube or circuit board or control box cover, which could cause a malfunction.

8. Reinstall the pressure control cover and screws.

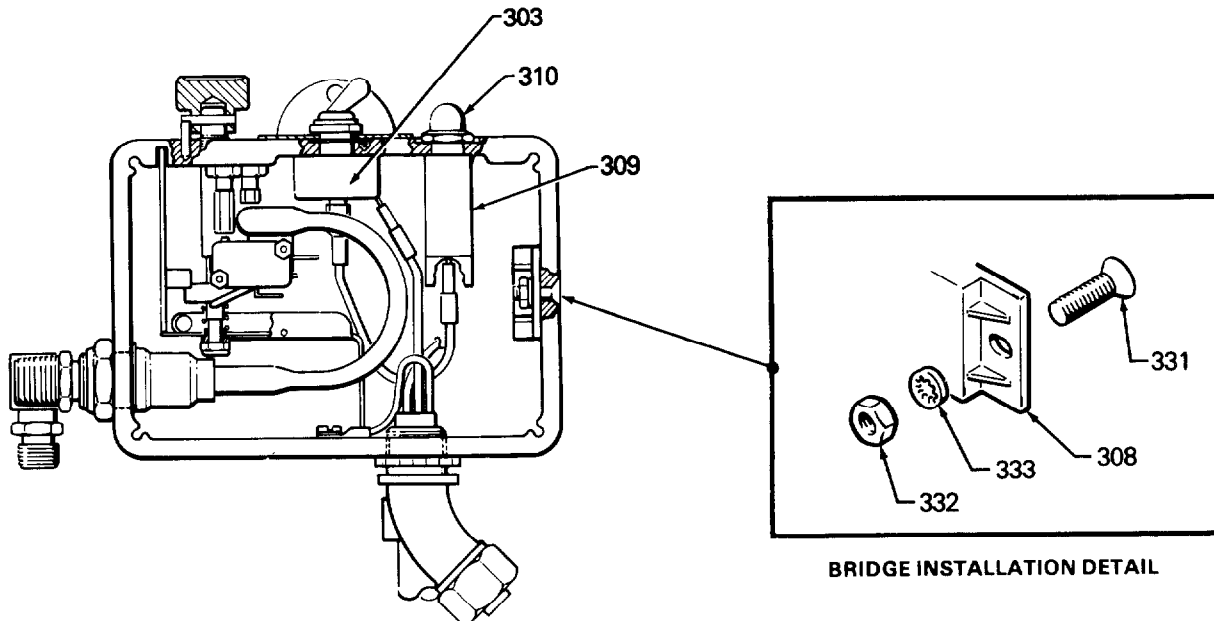

Fig 14

CIRCUIT BREAKER REPLACEMENT (See Fig 14)

WARNING

Before doing this procedure, follow the **Pressure Relief Procedure Warning** on page 13 to reduce the risk of an injection injury, injury from moving parts, or electric shock. Unplug the sprayer!

1. Remove the pressure control cover and screws.
2. Use a small screwdriver to slide the terminal adapter off the circuit breaker terminal.
3. Disconnect the single black wire from the circuit breaker (309) to the ON/OFF switch (303).
4. Use a 5/8" socket wrench to loosen the nut and boot (310) on the circuit breaker button.

5. Push down on the top of the circuit breaker and pull it out of the box.
6. Install the new circuit breaker in the reverse order of disassembly.
7. Reinstall the pressure control cover and screws.

CAUTION

Do not allow the circuit breaker contacts to touch the bourdon tube, which will cause a short. Tighten the circuit breaker nut firmly to prevent the circuit breaker from turning.

CIRCUIT BOARD REPLACEMENT (See Fig 15 and 16)

WARNING

Before doing this procedure, follow the **Pressure Relief Procedure Warning** on page 13 to reduce the risk of an injection injury, injury from moving parts, or electric shock. *Unplug the sprayer!*

1. Remove the pressure control cover and screws.
2. Turn the pressure control knob all the way counter-clockwise to the minimum setting to release spring tension on the circuit board (23). Also check to be sure only three or four threads of the pressure control knob shaft are exposed below the pressure adjustment nut (S). Back down the nut, if necessary. See Fig 13.

CAUTION

Step 2 is essential to reduce the risk of damaging the circuit board while removing or installing it.

3. Disconnect **ALL** wires from the board, including the two heavy black wires. Refer to Fig 16. Pay close attention to where connections are made.
4. To remove the board from the box, pull out the black plastic-tipped pin (330). Push the *bottom* of the circuit board toward the wall of the box and carefully slide the board out.
5. Install the board in the box at the same angle as it was removed. Reconnect the wires as indicated in Fig 16. Ease the pin (330) into the retainer.

CIRCUIT BOARD 820-358

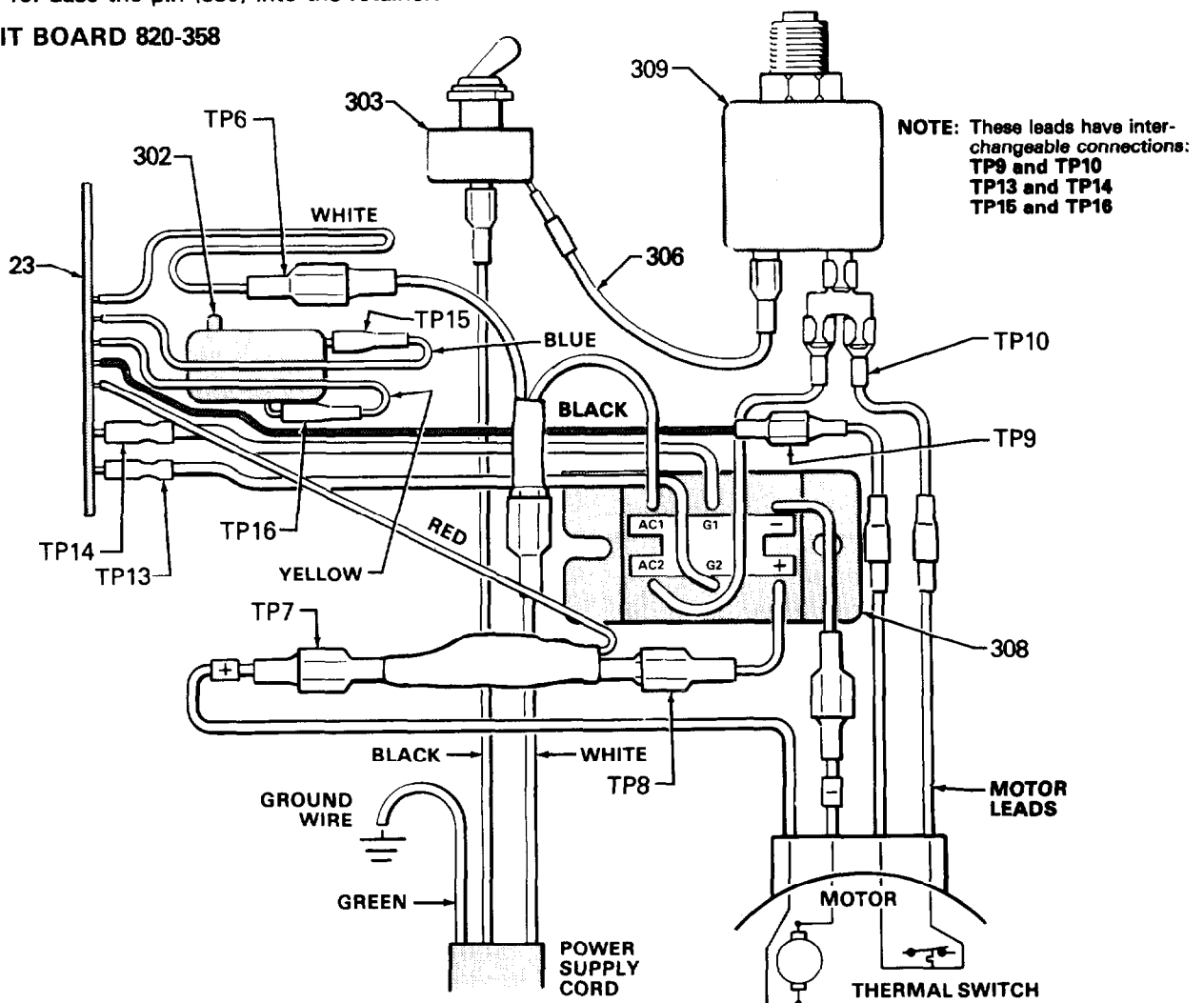

Fig 16

CAUTION

To reduce the risk of malfunction, be sure the flat blade of the insulated male connector are centered exactly in the wrap-around blade of the female connector when connections are made. Route all wires carefully to avoid interference with the circuit board, bourdon tube and pressure control cover.

6. Perform the **Stall Pressure Calibration** on page 27.

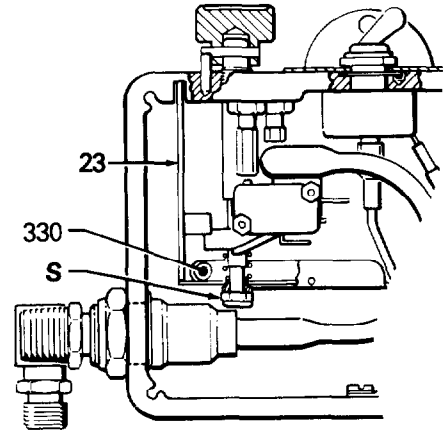

Fig 15

PRESSURE CONTROL REPLACEMENT (Refer to Fig 17)

WARNING

Before doing this procedure, follow the **Pressure Relief Procedure Warning** on page 13 to reduce the risk of an injection injury, injury from moving parts, or electric shock. Unplug the sprayer!

1. Disconnect the main fluid hose and the secondary fluid hose, if used, from the sprayer.
2. Disconnect the fluid hose (47) from between the displacement pump outlet nipple (46) and pressure control inlet nipple (344).
3. Hold the pressure control outlet nipple (341) firmly with a 3/4" open end wrench, and screw the tee (85) off of the nipple.

CAUTION

Do not allow the adapter (341) to turn while removing or installing the new pressure control assembly. Turning it can damage the sensitive bourdon tube. Hold the adapter firmly with a 3/4" open end wrench while screwing on the tee (85).

4. Remove the pressure control cover and screws (36,15), and disconnect the four motor leads at the appropriate terminals. See Fig 16, page 25.
5. Refer to "Circuit Board Replacement" on page 25, remove the circuit board and retain.
6. Remove the conduit (22).
7. Use a 1/2" open end wrench to loosen and remove the pressure control mounting screws (44) washers (40) and nuts (41) located below the pressure control box. Remove the box.
8. Install the new pressure control assembly in the reverse order of disassembly. Be sure to reinstall the conduit seal (5-not shown) around the wires in the conduit elbow (345) at the pressure control to prevent motor contamination from entering the control box.
9. Perform the pressure control calibration procedure starting on page 27, before regular operation of the sprayer.

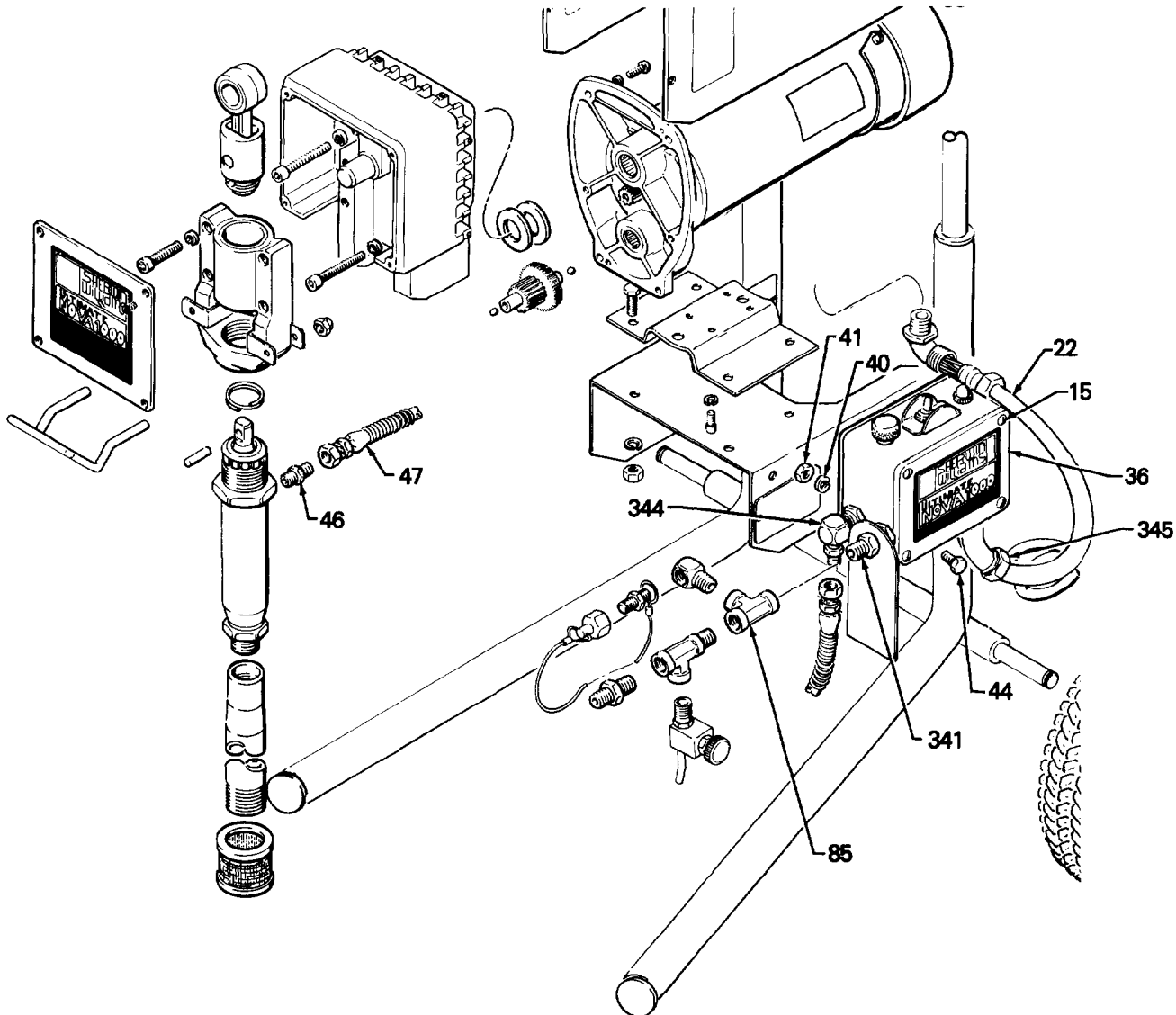

Fig 17

Stall Pressure Calibration

WARNING

USE EXTREME CAUTION WHEN PERFORMING THIS CALIBRATION PROCEDURE to reduce the risk of an injection injury or other serious bodily injury which can result from splashing, component rupture, electric shock, fire, explosion, or moving parts.

This procedure sets the sprayer to 3000 psi (210 bar) **MAXIMUM WORKING PRESSURE**. This procedure must be performed whenever a new or used circuit board, or pressure control assembly is removed and reinstalled or replaced, to be sure the sprayer is properly calibrated.

Improper calibration can cause the sprayer to over-pressurize and result in component rupture, fire or explosion. It may also prevent the sprayer from obtaining the maximum working pressure which would result in poor sprayer performance.

NEVER attempt to increase the fluid outlet pressure by performing this calibration in any other way. **NEVER EXCEED 3000 psi (210 bar) MAXIMUM WORKING PRESSURE**. Normal operation of the sprayer at higher pressures could result in component rupture, fire or explosion.

AVOID touching the wires in the pressure control assembly with your fingers or tools when the control box cover is removed to reduce the risk of electric shock.

Calibration Setup (See Fig 18 and 19)

1. Follow the **Pressure Relief Procedure Warning** on page 13. Remove the spray hose and gun. Install a 0.015" spray tip in the gun. Connect the gun to the *new* test hose and connect the hose to the sprayer outlet.
2. Remove the pressure control screws and cover.
3. Remove the elbow (88). Holding the nipple (341) with a wrench to prevent it from turning, rotate the tee (85) up and install the test gauge (X) in the tee (85). See Fig 18.
4. Place the pump suction tube in a 5 gallon pail of clean water.
5. Be sure the gun safety latch is engaged.
6. Use a 3/8" ignition wrench to turn the pressure adjustment nut (S) counterclockwise about two full turns. See Fig 19.
7. With the pressure control knob at the *minimum* setting, turn the sprayer switch ON. See Fig 18.

THE SPRAYER SHOULD NOT START!

If it does start, shut the sprayer switch OFF, disengage the gun safety latch, trigger the gun into a waste container until pressure is relieved. Engage the gun safety latch. Turn the pressure adjustment nut (S) a little further counterclockwise. Turn the sprayer on to be sure it *does not* start.

8. *Slowly* turn the pressure control knob clockwise to the maximum setting and hold it there. Use a 3/8" ignition wrench to slowly turn the pressure adjustment nut (S) clockwise until the test gauge reads **EXACTLY 3000 psi (210 bar)**.
9. The calibration procedure is now completed.

WARNING

Follow the **Pressure Relief Procedure Warning** on page 13.

CAUTION

To prevent pump corrosion, flush the water out of the pump, hose and gun with mineral spirits. Be sure to close the drain valve, first. Use the lowest pressure necessary to flush. Follow the **Pressure Relief Procedure Warning** on page 13. Leave the mineral spirits in the pump to protect it until you are ready to spray again.

10. Remove the test gauge assembly. Flush out water with mineral spirits.

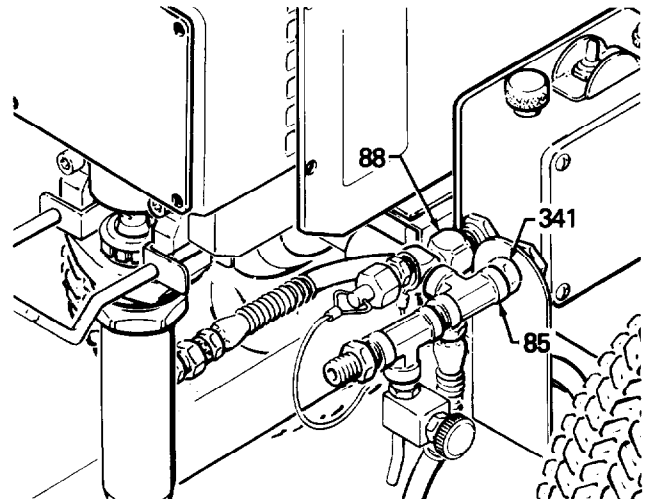

Fig 18

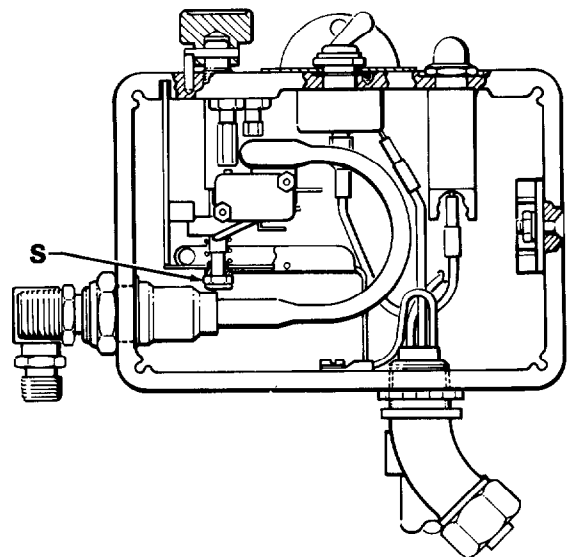

Fig 19

BEARING HOUSING & CONNECTING ROD REPLACEMENT (See Fig 20 and 21)

WARNING

Before doing this procedure, follow the **Pressure Relief Procedure Warning** on page 13 to reduce the risk of an injection injury, injury from moving parts or electric shock. Unplug the sprayer!

1. Stop the sprayer at the bottom of its stroke to get the crank (E) in its lowest position. If the crank (E) must be lowered manually, carefully rotate the blades of the fan with a screwdriver.
2. Remove the front cover and screws (31, 32).
3. Unscrew the suction tube (42) from the pump, holding a wrench on the pump intake valve to keep the pump from loosening.
4. Disconnect the pump outlet hose (47) from the displacement pump outlet nipple (46).
5. Use a screwdriver to push aside the retaining spring (35) at the top of the pump. Push the pin (20) out the rear.
6. Loosen the jam nut (38) with an adjustable wrench. Unscrew and remove the displacement pump.
7. Use a 3/16" hex key wrench to remove the four screws (33) and lockwashers (49) from the bearing housing.
8. Lightly tap the lower rear of the bearing housing (27) with a plastic mallet to loosen it from the drive housing. Then pull the bearing housing and the connecting rod assembly (29) straight off the drive housing.
9. Inspect the crank (E) for excessive wear and replace parts as needed.
10. Evenly lubricate the inside of the bronze bearing in the bearing housing with high quality motor oil. Liberally pack the roller bearing in the connecting rod assembly (29) with bearing grease.
11. Assemble the connecting rod and bearing housing (27).
12. Clean the mating surfaces of the bearing and drive housings.
13. Align the connecting rod with the crank (E) and carefully align the locating pins in the drive housing with the holes in the front cover (31). Push the bearing housing onto the drive housing or tap it into place with a plastic mallet.

CAUTION

DO NOT use the bearing housing screws (33) to try to align or seat the bearing housing; the bearing and drive housing will not align properly and will result in premature bearing wear.

14. Install the screws (33) and lockwashers (49) on the bearing housing and tighten evenly.
15. Screw the displacement pump about 3/4 of the way into the bearing housing (18). Hold the pin (20) up to the pin hole in the connecting rod assembly (29) and continue screwing in the pump until the pin slides easily into the hole. Back off the pump until the top threads of the pump cylinder are flush with the face of the bearing housing and the outlet nipple (46) is facing back. Push the retaining spring (35) into the groove all the way around the connecting rod. Tighten the locknut (38) very tight—about 75-85 ft-lb (102-115 N·m)—with a 2 in. open end wrench and a light hammer. See Fig 20.

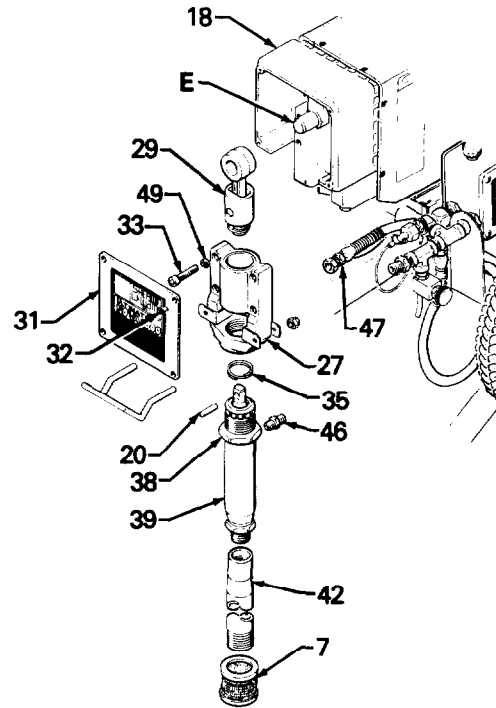

Fig 20

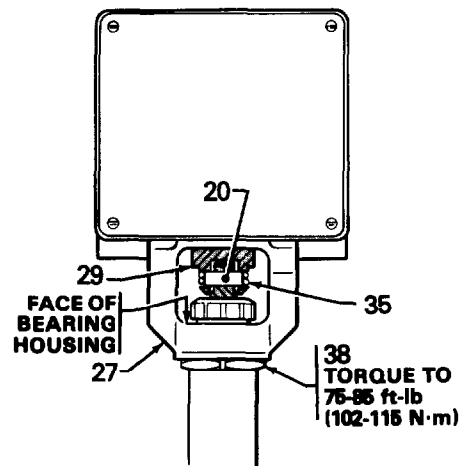

Fig 21

WARNING

Be sure the retaining spring (35) is firmly in the groove of the connecting rod, *all the way around*, to prevent the pin (20) from working loose due to vibration. See Fig 21.

If the pin works loose, it or other parts could break off due to the force of the pumping action. These parts could be projected through the air and result in serious bodily injury or property damage, including damage to the pump, connecting rod or bearing housing.

16. Reinstall the front cover and screws (31,32). Reconnect the suction tube (42) and pump outlet hose (47).

DRIVE HOUSING REPLACEMENT (See Fig 22)

WARNING

Before doing this procedure, follow the **Pressure Relief Procedure Warning** on page 13 to reduce the risk of an injection injury, injury from moving parts or electric shock. Unplug the sprayer!

NOTE: Stop the sprayer at the bottom of its stroke to get the crank (E) in its lowest position. To lower it manually, carefully rotate the blades of the fan with a screwdriver.

1. Remove the front cover and screws (31,32).
2. Disconnect the pump outlet hose (47) from the displacement pump outlet nipple (46).
3. Use a 3/16" hex key wrench to remove the four screws (33) and lockwashers (49) from the bearing housing.
4. Lightly tap the lower rear of the bearing housing (27) with a plastic mallet to loosen it from the drive housing. Then pull the bearing housing and connecting rod assembly straight off the drive housing.
5. Use a 1/4" hex key wrench to remove the two screws (51) and lockwashers (63) from the recess of the drive housing and the two screws (21) and lockwashers (63) from the rear of the motor front end bell (1b).
6. Lightly tap the drive housing with a plastic mallet to loosen it from the front end bell, then pull it straight off.

CAUTION

DO NOT allow the gear cluster (9) to fall when removing the drive housing (2). It is *easily* damaged if dropped. The gear may stay engaged in either the front end bell or the drive housing.

DO NOT lose the thrust balls (10) located at each end of the gear cluster (9) or allow them to fall between gears. The ball, which is heavily covered with grease, usually stays in the shaft recesses, but could be dislodged. If caught between gears and not removed, the balls will seriously damage the drive housing. If the balls are not in place, the bearings will wear prematurely.

7. Liberally apply bearing grease to the gear cluster (9). Check to be sure the thrust balls (10) are in place.
8. Place the bronze-colored washer (18) and then the silver-colored washer (18a) on the shaft protruding from the big gear in the drive housing (18). Align the gears and push the new drive housing straight onto the front end bell and locating pins.
9. Starting at Step 5 and working backwards, continue to reassemble the sprayer.

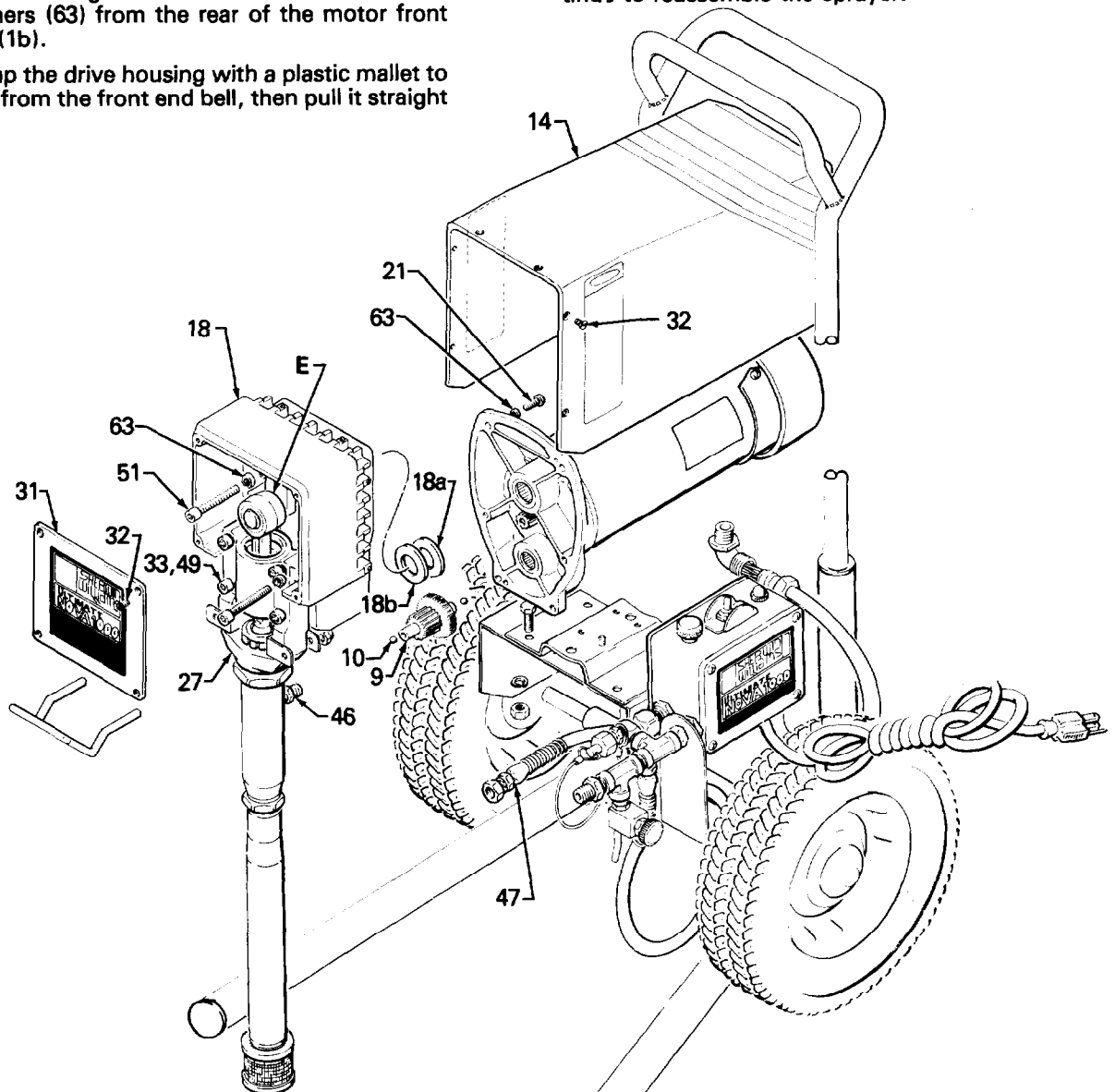

Fig 22

MOTOR REPLACEMENT (Refer to Fig 23)

WARNING

Before doing this procedure, follow the **Pressure Relief Procedure Warning** on page 13 to reduce the risk of an injection injury, injury from moving parts, or electric shock.

1. Disconnect the pump outlet hose (47) from the displacement pump outlet nipple (46).
2. Remove the screws (15) and pressure control cover (36) and disconnect the four motor leads.
3. Use an adjustable wrench to loosen the conduit connector nut (345) at the pressure control assembly (43).
4. Swing the conduit (22) away from the conduit connector.
5. Pull the motor leads through the elbow, one at a time.

CAUTION

Always pull the motor leads one at a time to avoid loosening the terminals which could result in a bad connection and poor sprayer performance.

6. Loosen the nut of the connector (54) at the motor and pull the conduit (22) away from the motor, then pull the leads through the conduit, one at a time.
7. Unscrew the connector elbow from the motor.
8. Pull the wires through the elbow, one at a time.
9. Remove the front cover and screws (31,32).
10. Remove the motor cover (14) and screws (64).
11. Use a 1/4" hex key wrench to remove the two screws (51) and washers (63) from the recess of the drive housing, and the two screws (21) and washers (63) from the lower rear of the motor front end bell (1b).
12. Use a plastic mallet to gently tap the displacement pump (39) from the rear to loosen the drive housing from the front end bell. Then pull the drive housing away from the end bell.

CAUTION

DO NOT allow the gear cluster (9) to fall when removing the drive housing (18). It is *easily* damaged if dropped. The cluster may stay engaged in either the front end bell or the drive housing.

DO NOT lose the thrust balls (10) located at each end of the gear cluster (9) or allow them to fall between gears. The ball, which is heavily covered with grease, usually stays in the gear recesses, but could be dislodged. If caught between gears and not removed, the balls will seriously damage the drive housing. If the balls are not in place, the bearings will wear prematurely.

13. While supporting the motor to keep the sprayer from tipping, remove the nuts (40), lockwashers (41), and capscrews (37) holding the motor mounting plate (72) to the frame. Lift the motor assembly off the frame.
14. Remove the mounting plate (72), four screws (79) and lockwashers (63) from the old motor, and install them on the new motor.

CAUTION

Be sure to install the correct length of screw. Longer screws will damage the motor.

15. Place the new motor assembly on the frame and align with the frame mounting holes. Install the screws (37), lockwashers (41), and nuts (40) tightly.
 16. Liberally grease the gear cluster (9) and pinion gear (O) and pack all bearings in the motor front end bell. Check to be sure the thrust balls (10) are in place.
 17. Place the bronze-colored washer (18b) and then the silver-colored washer (18a) on the shaft protruding from the big gear in the drive housing (18).
 18. Align the gears and push the drive housing (18) straight onto the front end bell and locating pins.
 19. Starting at Step 11 and working backwards, continue to reassemble the sprayer.
- NOTE:** Use a turning motion on the conduit when feeding wires through it.
20. Reinstall the conduit seal (5-not shown) around the wires in the conduit elbow (345) at the pressure control to keep contaminants from entering the pressure control.
 21. Reinstall the motor cover and pressure control cover.

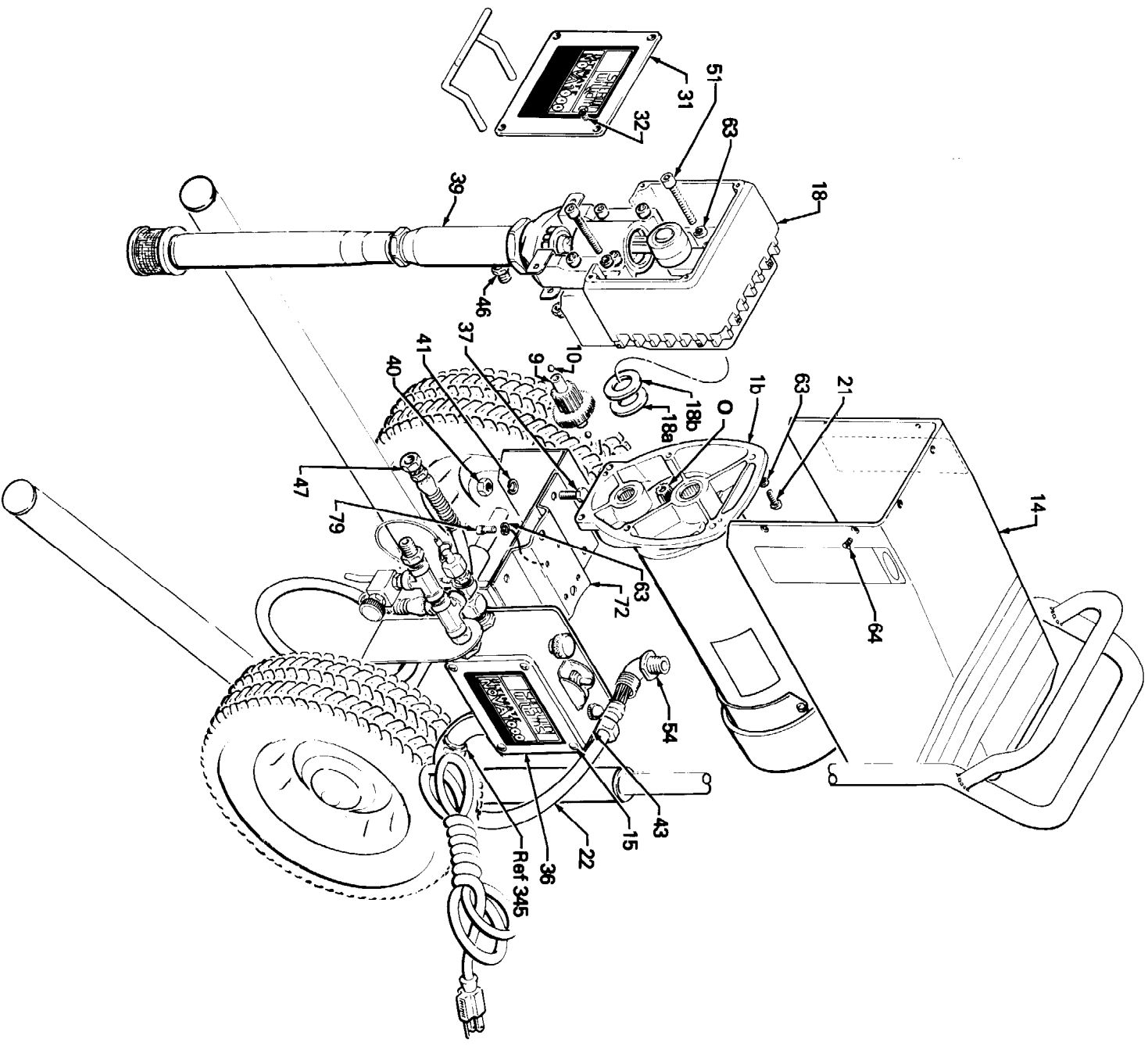

Fig 23

PARTS DRAWING

ULTIMATE NOVA™ 1000 Sprayers

Model 820-045, Series A
Includes items 1-89
Basic Sprayer

Model 820-053
Includes items 1-94
Complete Sprayer

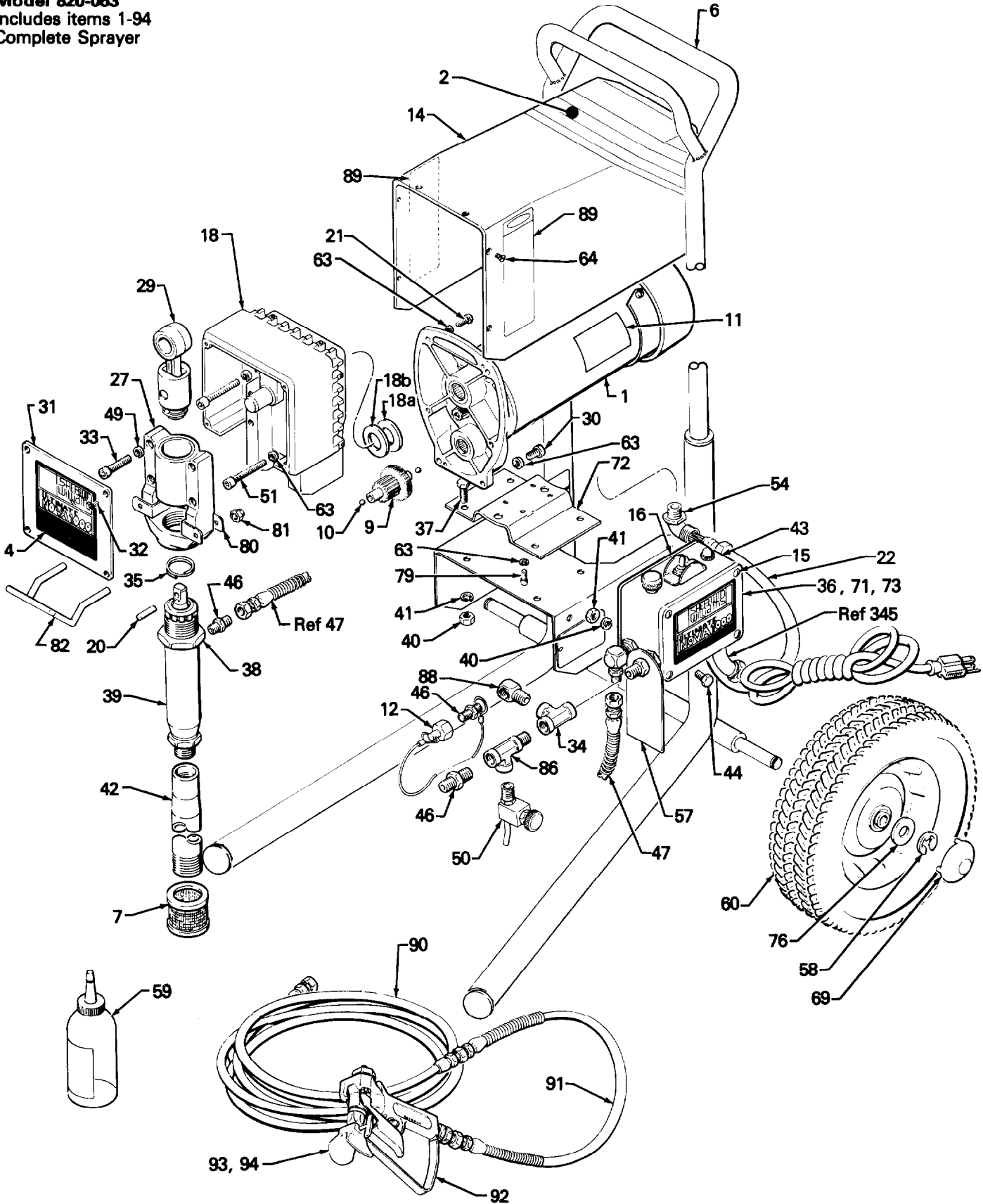

PARTS LIST

ULTIMATE NOVA™ 1000 Sprayers

Model 820-045, Series A
Includes items 1-89
Basic Sprayer

Model 820-053
Includes items 1-94
Complete Sprayer

REF NO.	PART NO.	DESCRIPTION	QTY	REF NO.	PART NO.	DESCRIPTION	QTY
1	820-493	MOTOR, electric Includes replaceable items 1a to 1c, and one each of items 10 and 11	1	39	820-356	PUMP, displacement; See 307-793, pump 217-577.	1
1a	820-441	.TERMINAL, female (see page 35)	2	40	820-258	LOCKWASHER, 5/16"	6
1b	820-447	.TERMINAL, female (see page 35)	1	41	820-267	NUT, heavy hex; 5/16-18 unc-2a	6
1c	820-429	.TERMINAL, snap on (see page 35)	1	42	820-399	TUBE, intake	1
2	820-037	LABEL, identification	1	43	820-503	PRESSURE CONTROL ASSEMBLY. See page 34	1
4	820-050	LABEL, identification	1	44	820-504	CAPSCREW, hex head; 5/16-unc-2a × 3/4"	2
5	820-491	SEAL, conduit (see page 34)	1	46	820-421	NIPPLE, 1/4 npt(m) × 1/4 npsm	3
6	820-494	FRAME Includes replaceable items 58 & 76	1	47	820-378	HOSE, grounded, nylon; 1/4" ID; cpld 1/4 npsm(f); 29" (715 mm) long; spring guard both ends	1
7	820-497	STRAINER	1	49	820-315	LOCKWASHER, spring; 3/8"	4
9	820-495	GEAR REDUCER	1	50	820-505	VALVE, pressure relief	1
10	820-457	BALL, 1/4", SST	2	51	820-506	CAPSCREW, sch; 1/4-20 × 2-3/4"	2
11	*178-934	LABEL, warning	1	54	820-507	CONNECTOR, conduit, 45°	1
12	820-498	CAP	1	57	*178-034	TAG, warning	1
14	820-052	SHIELD, motor; includes one of item 11	1	58	820-469	RING, retaining	2
15	820-325	SCREW, mach, oval head; thread forming; No. 10-24, Type C; 1/2"	8	59	820-014	THROAT SEAL LIQUID, 8 oz.	1
16	820-398	BRACKET, mounting	1	60	820-333	WHEEL	2
18	820-513	HOUSING, drive Includes 18a and 18b	1	63	820-273	LOCKWASHER, spring, 1/4"	10
18a	820-514	.WASHER, silver colored	1	69	820-263	HUBCAP	2
18b	820-515	.WASHER, bronze colored	1	71	*177-762	LABEL, warning	1
20	820-306	PIN	1	72	820-508	PLATE, mounting	1
21	820-486	CAPSCREW, sch; 1/4-20 × 5/8"	2	73	*820-049	LABEL, warning	1
22	820-323	CONDUIT, electrical; <i>specify length when ordering</i>	0.79 ft	76	820-294	WASHER, plain, 5/8"	2
23	820-358	CIRCUIT BOARD (see page 34)	1	79	820-509	CAPSCREW, soc hd; 1/4-20 unc-3a × 1/2"	4
27	820-499	HOUSING, bearing	1	80	820-510	BRACKET	2
29	820-496	ROD, connecting	1	81	820-511	NUT, retainer	2
30	820-500	CAPSCREW, sch; 1/4-20 unc-3a × 1.0"	2	82	820-512	HANGER, pail	1
31	820-501	COVER, housing	1	86	820-414	TEE, 1/4 npt(f × f × m)	1
32	820-307	SCREW, mach; filh; No. 8-32 × 1"	4	88	820-410	ELBOW, street, 1/4 npt(m × f)	1
33	820-416	CAPSCREW, sch; 3/8-16 unc-3a × 1-1/2"	4	89	*179-885	LABEL, warning	1
34	820-487	TEE, 1/4 npt(f)	1	90	820-516	HOSE, grounded, nylon; 3/8" ID; cpld 1/4 npsm(f); 50 ft (15 m) spring guard both ends	1
35	820-304	SPRING, retaining	1	91	820-517	HOSE, grounded, nylon; 3/16" ID; cpld 1/4 npsm(f); 3 ft (0.9 m); spring guard both ends	1
36	820-054	COVER, pressure control Includes items 71 & 73	1	92	820-518	SPRAY GUN; See 307-614 for parts	1
37	820-502	CAPSCREW, hex head; 5/16-unc-2a × 7/8"	4	93	820-519	SPRAY TIP KIT, Reverse-A-Clean III	1
38	820-353	NUT, hex	1	94	—	SPRAY TIP OF CHOICE	1

*Extra Warning labels and tags available at no charge.

HOW TO ORDER REPLACEMENT PARTS

1. To be sure you receive the correct replacement parts, kit or accessories, always give all of the information requested in the chart below.
2. Check the parts list to identify the correct part number; **do not use the ref. no. when ordering.**
3. Order all parts from your nearest Graco distributor.

6 digit PART NUMBER	QTY	PART DESCRIPTION

PRESSURE CONTROL ASSEMBLY 820-361

Includes items 301 to 345

NOTE: A circuit board is not included with the pressure control assembly 820-361. Order part no. 820-358 (ref. no. 23, page 32) separately.

The terminals listed in this parts list are shown in the wiring diagram on page 35.

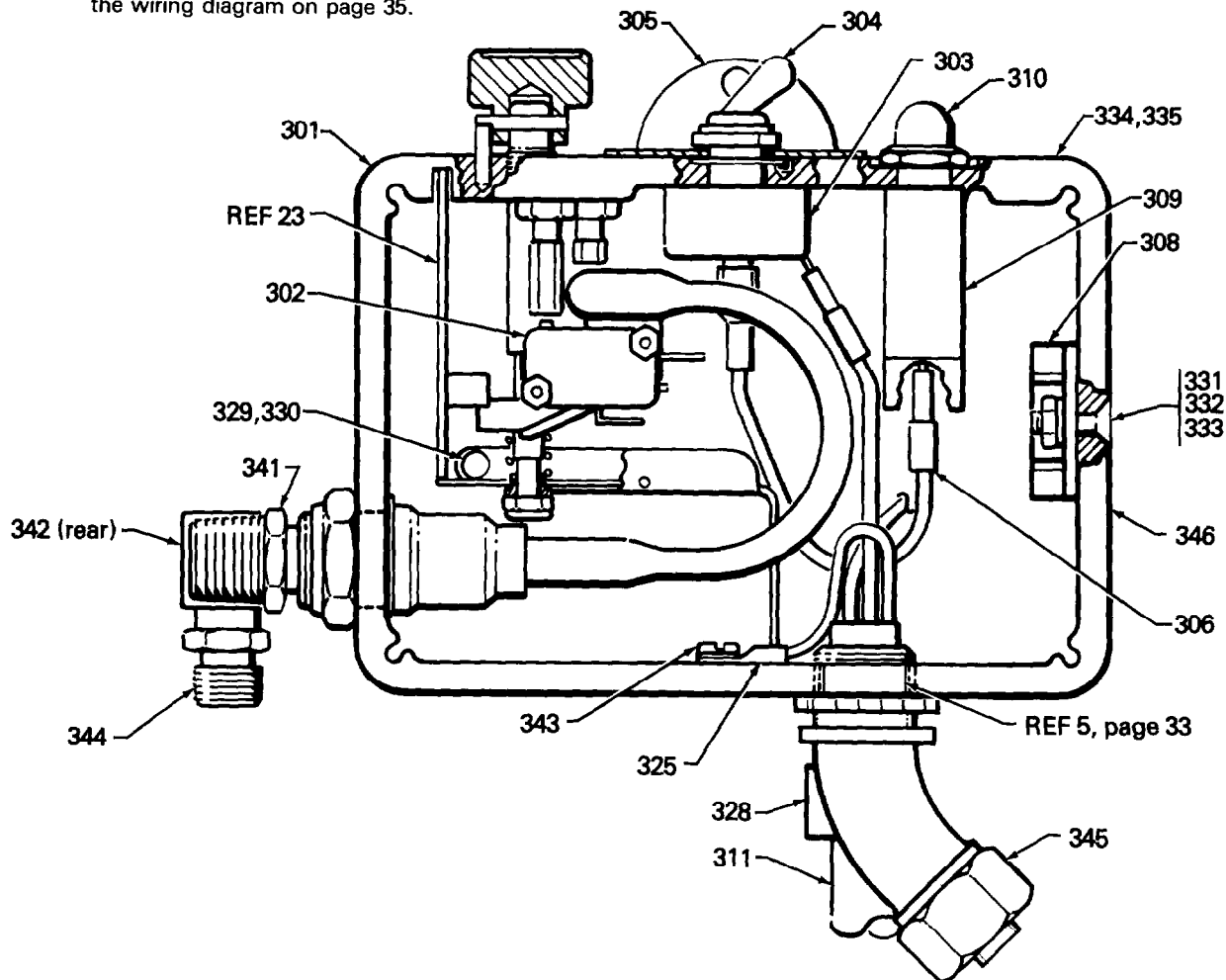

REF PART NO. NO.	DESCRIPTION	QTY	REF PART NO. NO.	DESCRIPTION	QTY
301	820-375 BARE PRESSURE CONTROL BOX Includes items 302 to 305	1	328	820-431 BUSHING, strain relief	1
302	820-450 .MICROSWITCH	1	329	820-434 TIP, pin, black plastic	1
303	820-342 ON/OFF SWITCH	1	330	820-449 PIN	1
304	820-341 BOOT, ON/OFF switch	1	331	820-427 SCREW, machine, flat head; No. 10-24 x 5/8" long	2
305	820-433 GUARD, locking	1	332	820-425 NUT, hex, mscr, No. 10-24 thd	2
306	820-451 JUMPER WIRE	1	333	820-426 LOCKWASHER, internal, shakeproof; No. 10	2
308	820-362 BRIDGE, rectifier, SCR	1	334	**178-797 LABEL, WARNING	1
309	820-366 CIRCUIT BREAKER	1	335	**178-035 LABEL, WARNING	1
310	820-432 BOOT, circuit breaker	1	336	820-436 TERMINAL, male	2
311	820-363 CORD, power supply	1	337	820-446 TERMINAL, female	1
312	820-442 ADAPTER, terminal	1	338	820-447 TERMINAL, male	1
314	820-441 TERMINAL, male	3	341	820-420 ADAPTER, 3/8 npt(m) x 1/2 npt(m)	1
316	820-444 TERMINAL, male	2	342	820-410 ELBOW, street; 1/4 npt(m x f)	1
317	820-445 TERMINAL, male	1	343	820-424 SCREW mach, slotted pan hd; No. 8 x 5/16" long	1
318	820-437 TERMINAL, female	1	344	820-421 NIPPLE, 1/4 npt(m) x 1/4 npsm	1
319	820-435 TERMINAL, female	1	345	820-506 CONNECTOR, conduit	1
320	820-440 TERMINAL, female	1	346	**180-962 LABEL, Warning	1
321	820-429 TERMINAL, male	1			
322	820-430 TERMINAL, female	1			
323	820-439 TERMINAL, female	3			
324	820-438 TERMINAL, female	1			
325	820-428 TERMINAL, ring	1			
327	820-448 LOCKWASHER, No. 8, internal	1			

***Warning labels and tags supplied at no charge.*

See "How To Order Replacement Parts" on page 33.

CIRCUIT BOARD 820-358

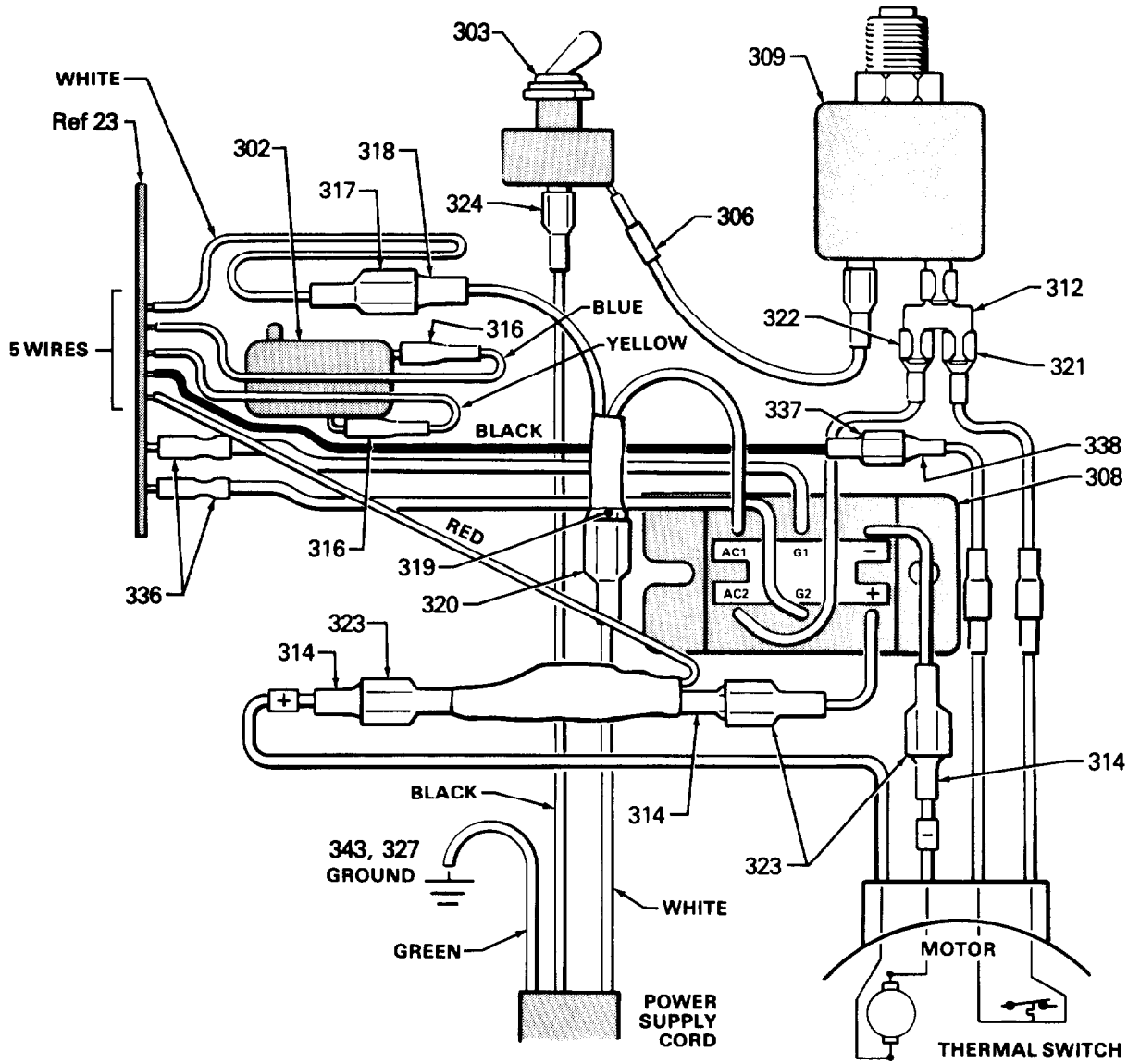

TECHNICAL DATA

Power Requirements : 115 VAC, 60 Hz, 1 Phase, 15 AMP minimum
Operating Range : 500-3000 psi (35-210 bar)
Cycles/Gallon (liter) : 200 (53)
Maximum Delivery : .85 GPM (3.2 liter/min)
Power Cord : No. 14 AWG, 3 wire, 8'6" (2.5 m) long
Inlet Paint Strainer : 16 mesh, 1190 micron,
Stainless Steel Screen, reusable
Pump Inlet Size : 3/4 npt w/30° I.D. chamfer
Fluid Outlet Size : Primary: 1/4 npsm(m)
Secondary: 1/4 npt(m)
Weight : 100 lb (45 Kg) approximately
Dimensions : Width: 22.5" (571.5 mm)
Height: 28.0" (711.2 mm)
Length: 26.0" (660.4 mm)