

AIRLESSCO PRESSURE WASHERS
MODELS AND SPECIFICATIONS

MODEL	PWD2500-5	PWD3000-3.5	PWD3000-6
PART NO.	168-003DH	168-004DH	169-002DB
MAX PSI	2500 PSI	3000 PSI	3000 PSI
MAX GPM	5 GPM	3.5 GPM	6 GPM
MIN NOZZLE SIZE	NO.5	NO. 4	NO.6
ENGINE HP	11 HP	11 HP	18 HP
WEIGHT	159 LBS.	159 LBS.	197 LBS.
NOZZLES	0, 15, 25, 40 FAN -----		
PUMP (Use a 30 W Nondetergent Oil)	168-015	168-016	TS 2021
UNLOADER	K5-2	K5-1	K5-2
GEAR REDUCER			GR1000
STARTING	RECOIL START -----		

STATE MODEL WHEN ORDERING NOZZLES, CHEMICAL INJECTOR OR SANDBLASTING ATTACHMENT.

PART NO. 176-004, QUICK DISCONNECT *(Base - must have for nozzle)*

NOZZLE ORDERING CHART

			<u>AIRLESSCO PRESSURE WASHERS</u>		
<u>NOZZLE</u>		<u>DEGREE</u>	<u>168-003DH</u>	<u>168-004DH</u>	<u>169-002</u>
<u>PART NO.</u>	<u>SIZE</u>	<u>OF FAN</u>	<u>2500-5</u>	<u>3000-3.5</u>	<u>3000-6</u>
78-00040	0004	O		X	
78-00050	0005	O	X		
78-00060	0006	O			X
78-15040	1504	15		X	
78-15050	1505	15	X		
78-15060	1506	15			X
78-25040	2504	25		X	
78-25050	2505	25	X		
78-25060	2506	25			X
78-40040	4004	40		X	
78-40050	4005	40	X		
78-40060	4006	40			X
78-40300	4030	40	CHEM INJECTOR ALL MODELS		

TABLE OF CONTENTS

WARNINGS	PGE 1
TIPS OR NOZZLES	2
NOZZLE SELECTION GUIDE	2 & 3
PRESSURE WASHER COMPONENTS	3 & 4
EQUIPMENT CARE & MAINTENANCE..	5
OPERATING INSTRUCTIONS	6
SPRAY GUN	7
HIGH PRES. QUICK DISCONNECT FITTINGS	7
HIGH PRESSURE PUMP	8
REGULATOR UNLOADER	9
GEAR REDUCER	9
PARTS LIST - FRAME	10
CHEMICAL INJECTOR	11
SANDBLASTING KIT	12
SERVICING & TROUBLESHOOTING -PUMP	13 14,15

WARNINGS

HIGH PRESSURE SPRAY CAN CAUSE EXTREMELY SERIOUS INJURY. NEVER PUT YOUR HAND OR FINGERS IN FRONT OF GUN. NEVER POINT THE GUN AT YOUR BODY OR AT ANYONE ELSE.

- * Always shut off pump and relieve fluid pressure in system by opening control handle if unit is left unattended or before removing or installing accessories. **NOTE: Shutting off power by itself may not relieve fluid pressure.**
- * When control handle is not in use, engage trigger safety to prevent accidental spraying.
- * Do not allow kinks to form in hose between pump and control handle as this will reduce safety factor.
- * Always wear face shield, eye goggles and protective clothing and gloves, so spray containing chemicals does not contact eyes, ears, nose or skin. If chemicals do contact skin or eyes flush immediately with large amounts of water and seek medical attention.

DANGER: Do not run the engine in an enclosed area. Exhaust gases contain carbon monoxide, an odorless and deadly poison.

WARNING: Do not run engine at excessive speed. Excessive speeds increase the danger of personal injury and voids warranty.

A FIRE OR EXPLOSION CAN OCCUR RESULTING IN PERSONAL INJURY IF THE FOLLOWING INSTRUCTIONS ARE NOT FOLLOWED:

- * DO NOT FILL GASOLINE TANK while engine is running. Allow engine to cool before refueling.
- * Do not operate the engine when an odor of gasoline is present or other explosive conditions exist.
- * If gasoline is spilled, move machine away from the area of the spill and avoid creating any source of ignition until the gasoline has been cleaned up.
- * Do not store, spill or use gasoline near an open flame, or device such as stove, furnace, water heater which utilizes a pilot light, or devices which can create a spark.
- * Refuel outdoors or only in well ventilated areas.
- * DO NOT operate engine without a muffler. Inspect muffler periodically and replace as necessary. Clean muffler area to prevent dirt & combustible material from accumulating.
- * Exhaust fumes are poisonous. Do not operate except in open and well ventilated area.
- * Do not operate the engine if air cleaner or cover directly over the carburetor air intake is removed.
- * Do not choke carburetor to stop engine.
- * Do not tamper with the engine speed.
- * Do not touch hot muffler, cylinders or fins as contact may cause burns.
- * Dirt or other debris in cooling fins or governor parts, can affect engine speed.
- * To prevent hand or arm injury, always pull starter cord rapidly to avoid kickback.
- * To prevent accidental starting when servicing, always remove spark plug or wire from the spark plug and insert in holding tab & disconnect negative wire from battery terminal if equipped with a 12 volt starting system.

SOME TIPS TO HELP YOU GET MOST FROM YOUR MACHINE

- * Select the right tip for the job.
- * Never allow anyone into your work area & risk injury.
- * Approach target from a slight angle ("sweep" surface)
- * Always wear face shield or eye protection.
- * Turn machine off and relieve pressure from hose & system before disconnecting hoses, control handle (gun) or tips.
- * Cover any exposed electric sockets, plugs, lights or other exposed electrical connections.
- Do not kink the High Pressure Hose, the wires inside may bend and become weak or break.
- * Always consider which way the wind is blowing to avoid overspraying.
- * Spray surface conditioners so you are "Up Wind".
- * Never allow surface conditioners, soap or other chemicals to get on vegetation. Use plastic sheeting to protect.
- * Keep the quick couplers out of dirt and sand. If they should have dirt or other debris on them, clean the quick coupler thoroughly before using.
- * Do not allow your hand or body to come in contact with water spray. **HANDLE AS YOU WOULD A LOADED FIRE-ARM.**

TIPS (OR NOZZLES)

THE QUICK COUPLER TIPS OR NOZZLES are inserted into the end of the WAND by means of a QUICK COUPLER. Tips are supplied in the four most popular sizes & can do many jobs for you. You MUST seat the tip into the quick coupler firmly and make sure the quick coupler is closed. If you have a leak at the tip around the quick coupler, you have lost the "O" ring inside the quick coupler. If lost, the "O" ring MUST BE REPLACED!

CAUTION: Failure to lock quick coupler into place can result in personal injury and loss of "O" ring on female coupler. Danger signals are indicated by water leakage.

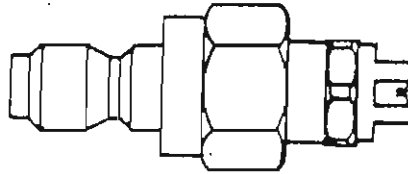

Learning what each tip can do for you will make your AIRLESSCO machine more valuable and will allow you to do your cleaning jobs faster and more effectively. By experimenting, you will find that different tips do the job better and that moving the wand closer to and farther from the area to be cleaned will also change the way the machine will work for you.

You should always start each new job away from the target and move closer as you see the need. Be careful: you can damage some surfaces if the pressure is too concentrated and too close.

NOZZLE SELECTION GUIDE

The pressure and volume of a pressure washer are determined by the size of the opening (orifice) in the nozzle. There are numbers on the nozzle which explain its size. The first two numbers indicate the size of the spray angle (00 means 0-degree, 15 means 15 degree etc.) The last numbers indicate the size of the orifice. This is not a measurement of an inch, but a standardized measurement.

THE 0 DEGREE NOZZLE

This is the blasting nozzle. It delivers a very concentrated stream of water. Care should be used to avoid damaging wood or fragile surfaces. **WARNING:** This nozzle must not be used on rental machines supplied to homeowners or non-contractors.



THE 15 DEGREE NOZZLE - 3-4"

This is a chiseling nozzle. The spray should be directed at a 45 degree angle to the surface and used like a scraper to remove paint, grease and dirt. This is the most used tip of all.

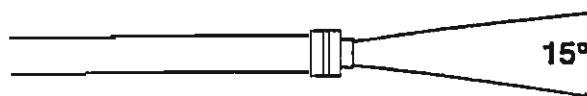

NOZZLE SELECTION GUIDE CONTINUED

THE 25 DEGREE NOZZLE - 5-6"

This is a flushing nozzle. It gives wider coverage and is used when the area being cleaned would be damaged by a narrower tip.

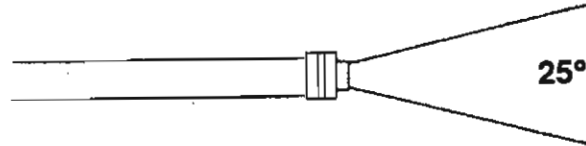

THE 40 DEGREE NOZZLE - 8-10"

This is a wash nozzle. Its wide spray pattern disperses the water pressure over a large area and is recommended for rinsing and moderate washing.

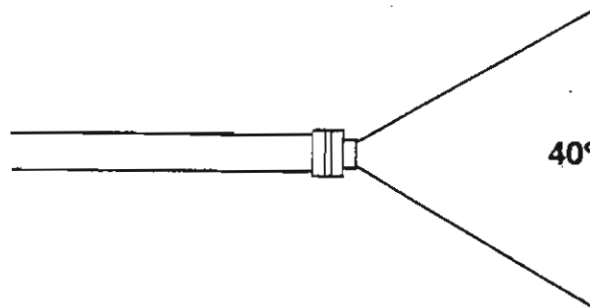

TIPS WILL WEAR in time. The more you use a tip the more it will wear. A worn tip will cause a significant DROP IN PRESSURE. Check and replace your tips frequently.

QUICK COUPLER

The quick coupler allows you to attach different devices together quick and secure. To use, simply slide the collar back and insert the plug. "Snap" home the collar. Make sure the plug is securely seated. It's always a good idea to "tug" on the two parts to make sure they are firmly seated together.

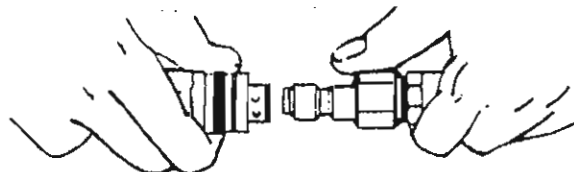

SOCKET

PLUG

Always make sure the "O" ring is in place inside the quick coupler. To see if the "O" ring is in place, make sure the Pressure Washer is off and all system pressure has been relieved then you may look into the quick coupler at the collar (female) side of the quick coupler. You will be able to see the "O" ring inside. If the "O" ring is missing, it must be replaced to ensure a good pressure seal.

INLET WATER FILTER

The inlet water screen is intended to prevent debris from entering the pump and causing damage. DO NOT OPERATE the machine without the Inlet Water Screen in place.

The Inlet Water Screen is stainless steel and should be removed and cleaned every 25 hours of operation. If your water conditions are worse than normal it should be cleaned more often.

HIGH PRESSURE HOSE

The hose provided by AIRLESSCO is selected from the finest hoses available and is intended to be used on your machine only.

Do NOT use the pressure hose for any other purpose and do not substitute any other hoses for high pressure hose.

If the hose becomes frayed or has any cuts on it it must be replaced.

Do not allow your pressure hoses to be run over by any type of vehicle.

SPRAY GUN OR CONTROL HANDLE

The gun included with your machine should always be treated as a loaded firearm.

HIGH PRESSURE WATER IS DANGEROUS and should never be directed at any person or any parts of your body.

Your gun has safety features you should use. The Trigger Lock should be in place any time the gun is not being used. The gun also has a spring loaded trigger so that is closed when the trigger is released.

DO NOT TAPE OR TIE, in any way render the spring device inoperative.

WAND

The WAND supplied with your machine should be handled with care. If the wand is bent it should be replaced.

CHEMICAL INJECTOR SEE PAGE 11

Your machine is equipped to use a CHEMICAL INJECTOR for those jobs that require more than water cleaning. The AIRLESSCO CHEMICAL INJECTOR will allow you to soak the surface with a liquid chemical or detergent.

If you need to use SURFACE CONDITIONERS, SUCH AS SOAPS AND DEGREASERS YOU MUST USE A CHEMICAL INJECTOR.

DO NOT PUMP ANY SURFACE CONDITIONS or any other medium other than water through the high pressure pump. To do so could damage the pump and void your warranty.

SAND INJECTOR SEE PAGE 12

AIRLESSCO units are equipped to use a SAND INJECTOR SYSTEM. Water Sandblasting is an extremely effective way of cleaning. The AIRLESSCO SAND BLASTING INJECTOR allows sand to flow into the high pressure water stream to create a powerful cleaning system. Dry sandblasting is being replaced by wet sandblasting. SOME USES: Removing boat barnacles, rust, graffiti, blasting painted surfaces down to metal for repainting.

EQUIPMENT CARE AND MAINTENANCE

PRESSURE PUMP

1. Use 30 Weight Non Detergent Oil.
2. Change oil after first fifty (50) hours of operation, thereafter every 500 hours of operation.
3. Check oil level before starting daily. Check sighting glass & dip stick & fill to 1/2 full.
4. Never run the pump dry, always turn on the water supply before starting the pump.
5. Never pump chemicals or acid through your pump - use a chemical injector.
6. Pump must be protected from freezing conditions. (see instructions below)

GASOLINE ENGINE

1. Read your engine operation manual for type of oil, when to change oil and for preventative procedures.
2. Never tamper with engine speed.

GEAR REDUCER (CLOSE COUPLER)

1. Change oil every 500 hours.
2. Use 90 W oil Hypoid/Antifoam.
3. Check oil level daily (sighting glass & dipstick) Fill to 1/2 full.

WATER FILTER

1. Never run the pump without a water filter.
2. Clean the filter every 25 hours of operation.

IMPORTANT: Turn the machine off and relieve pressure from hose and system before disconnecting hoses, shut-off gun or nozzles.
Turn the machine off and relieve pressure whenever the unit is left unattended.

AFTER EACH USE, WIPE ENTIRE UNIT DOWN (WAIT UNTIL ENGINE IS COOL) WITH CLEAN, DRY CLOTH.

******* NOTE *******

**DAMAGE DUE TO FREEZING IS NOT
COVERED UNDER WARRANTY**

If freezing conditions are prevalent in your area, use the following procedure to prevent damage to the unit.

1. Put switch in "OFF" position.
2. Remove the spark plug wire from the spark plug and pull starter rope or push starter button (if provided) to turn the engine over a few times to get excess water out of the pump.
3. Drain the High Pressure Hose after disconnecting.
4. Make sure to remove all water from all parts of the system.
5. Alternate method: use a 50% solution of Anti-freeze. Make sure entire system is included.

OPERATING INSTRUCTIONS

***** CAUTION *****

Before using your Airlessco Pressure Washer you should insure that the water supply is ample. To do this, connect a standard garden hose (you should use a hose of 3/4" inside diameter) to a water outlet and using a five gallon bucket see if you can fill the bucket in under one minute.

***** CHECK OIL LEVELS DAILY *****

Check Gear Reducer (Close Coupler), Pressure Pump and Engine Oil levels daily. Refer to Equipment Care and Maintenance Section

1. Move machine to an open area - never run in an enclosed area.
2. Check oils.
3. Add gasoline. Do not add gasoline while engine is running or to a hot engine.
4. After insuring ample water supply, connect garden hose. (see instructions above)
5. Using the High Pressure Hose- Quick Coupler plug end (see page 3), attach the high pressure hose to the socket of the regulator unloader making sure the quick coupler is properly closed.
6. Using the quick coupler plug at bottom of gun, attach the high pressure hose socket and close quick coupler.
7. Select and install the desired tip into the socket at end of wand and close quick coupler.
8. Turn on water and pull trigger on gun. Water should come out end of wand. It is essential that water flows through the gun during start up.
9. Start engine by turning switch (if provided) to "ON".
10. Move choke lever to "CHOKE". (Choking is not necessary if engine is warm.)
11. Sharply pull starter rope or press starter button (if electric start) and start engine.
12. As soon as engine starts, move choke lever to OFF position and let engine come to operating temperature. This should take about one minute.
13. After engine is running smoothly, make sure the direction the gun is pointing is clear and pull trigger.
14. Protect against surface damage by trying different nozzles, angles and distances.

PREPARATION INSTRUCTIONS BEFORE WASHING OR REPAINTING YOUR HOUSE

1. Please read all safety warnings.
2. If walls are badly stained, mildewed or soiled, detergents and the Chemical Injector is recommended. A strong cleanser or tri-sodium phosphate works well to remove stains. Bleaches help to kill mildew.
3. Cover outdoor light & electrical fixtures with plastic bags.
4. Protect flush receptacles with plastic tape.
5. Note Location of vent openings. Do not spray into these openings.
6. Protect landscaping with plastic covers. This helps in clean up. (especially when using chemicals and blasting off paint)
7. General Washing Technique: Is starting from the highest point. When working from a ladder make sure it is positioned so you are spraying away from yourself- never spray directly overhead.
8. Start flushing debris out of gutters using a 15 degree nozzle about 3 feet away.
9. Wash thoroughly underhand portion of soffit, spraying from a distance of 12" to 18".

10. When cleaning the sides of your house, work from the top to the bottom using overlapping strokes. If using chemicals or soap apply solution from bottom to top and then rinse from the top to the bottom.
11. When cleaning around windows, approach it cautiously. If panes are not secure or not well caulked, they can break from the impact of the high pressure spray. (Use a wider nozzle and start at a distance and approach cautiously.

TO REMOVE PEELING PAINT

1. Start at the highest point, using a 15 degree nozzle.
2. Spray should be directed 4 - 12" from the surface at an angle of 45 degrees. Work the spray like a chisel.
3. On the soffit, use a more parallel angle. It will peel off in large sheets if you can get beneath it.
4. Spray in a back and forth motion, always trying to get beneath the peeling paint. Be sure to get as much paint as will come off and don't be concerned about the paint that remains - it is well bonded enough to not cause a problem.
5. Use a steel brush on paint edges that curl up.

SPRAY GUN ST-2000

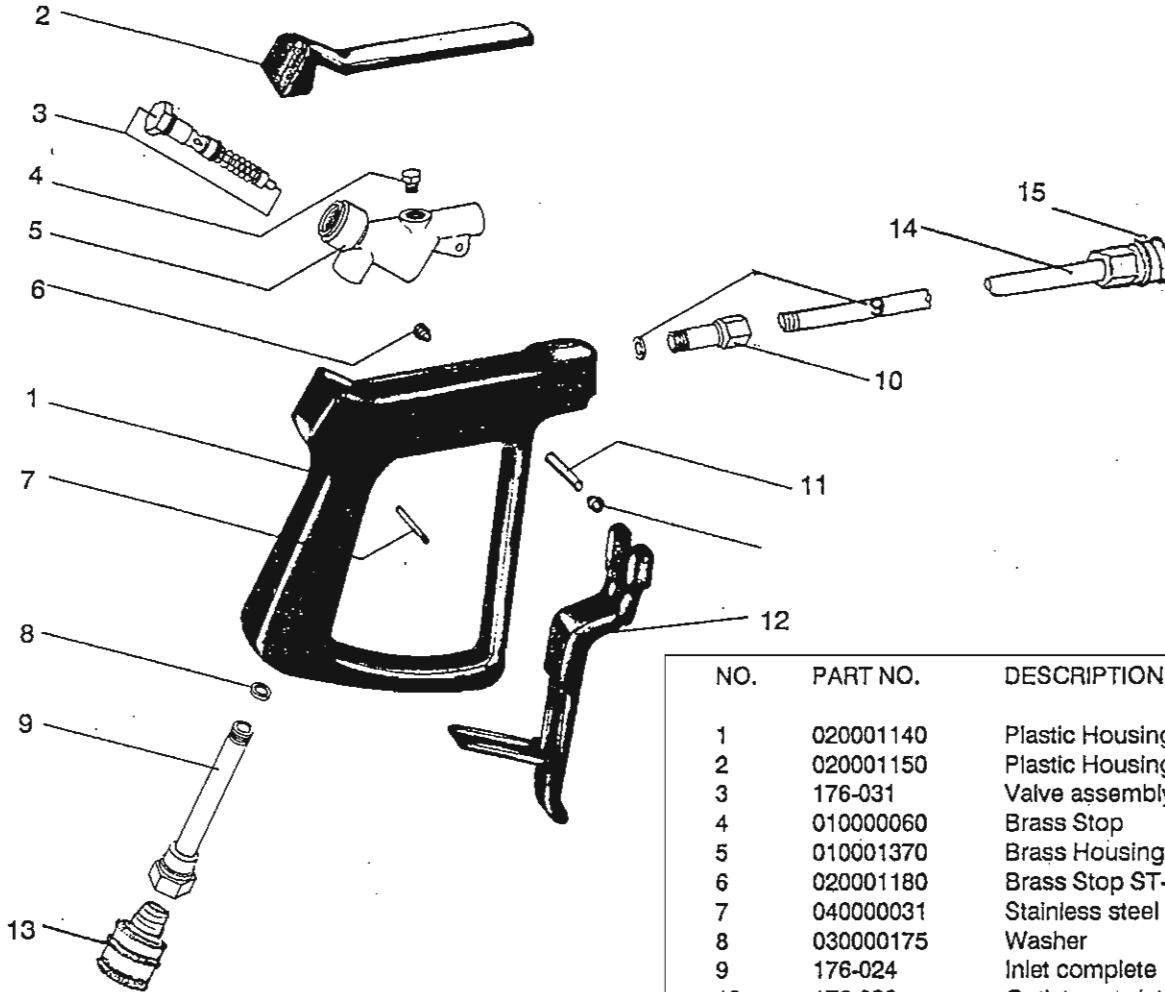

PART NO. 176-001 GUN ONLY
 PART NO. 176-001 W/F GUN, WAND & QUICK DISCONNECT

NO.	PART NO.	DESCRIPTION
1	020001140	Plastic Housing
2	020001150	Plastic Housing Cover
3	176-031	Valve assembly complete
4	010000060	Brass Stop
5	010001370	Brass Housing
6	020001180	Brass Stop ST-2000
7	040000031	Stainless steel pin 5 x 20
8	030000175	Washer
9	176-024	Inlet complete
10	176-023	Outlet complete
11	010001390	Brass pin
12	176-026	Trigger complete
13	100-021	3/8" Quick Disconnect Female
14	176-003	Wand
15	176-00	1/4" Quick Disconnect Female

HIGH PRESSURE QUICK DISCONNECT FITTINGS

DO NOT USE ON AIRLESS SPRAY HOSE.

Made of brass and/or plated steel. The fittings eliminate the need to "screw on hose. Just a quick push pull and you have a secure connection. The 3/8" size is used for water outlet and hose.

FOR QUICK DISCONNECT SYSTEM ORDER PART NOS. 001-020 AND 100-022.



100-020

100-022

100-020 QUICK DISC 3/8 NPTF 3T21
 100-022 QUICK DISC 3/8 NPTF 3s21

Part No. 168-015 - 2500-5
 Part No. 168-016 - 3000-3.5

GENERAL PUMP INCORPORATED

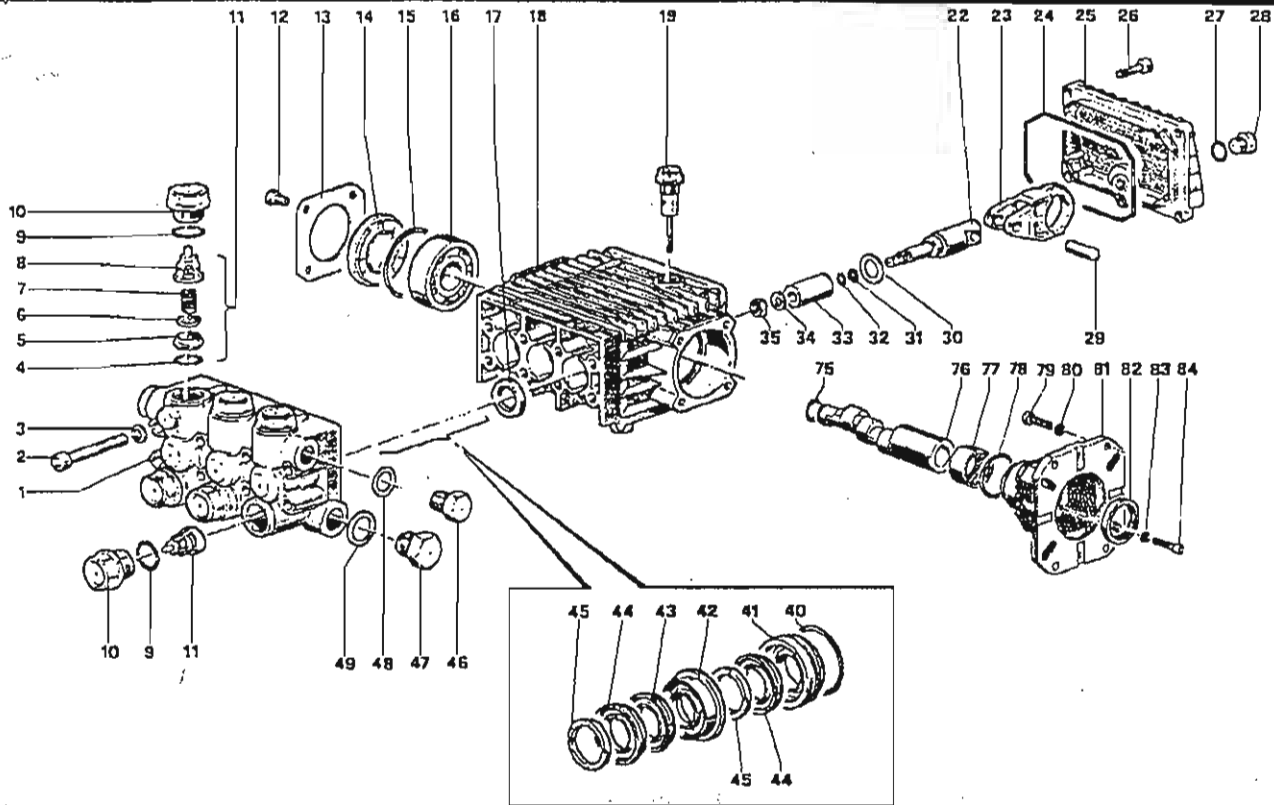

PARTS LIST

ITEM	PART NO.	KIT NO.	DESCRIPTION	QTY.	ITEM	PART NO.	KIT NO.	DESCRIPTION	QTY.	ITEM	PART NO.	KIT NO.	DESCRIPTION	QTY.
	44.1200.41		Pump Head	1	19.	98.2103.00		Oil Dip Stick	1	43.	90.2622.00	88,130	Packing	3
	99.3175.00		Screw	8	22.	44.0500.66		Piston Guide	3	44.	90.2620.00	88,130	Packing	6
3.	96.7014.00		Washer	8	23.	44.0300.22		Connecting Rod	3	45.	51.1000.51	90,130	Head Ring	6
4.	90.3841.00	123	O-Ring	6	24.	90.3920.00		O-Ring	1	46.	98.2100.00		Cap Screw	1
5.	36.2003.66	123	Valve Seat	6	25.	44.1600.22		Rear Cover	1	47.	98.2176.00		Cap Screw	1
6.	36.2001.76	123	Valve	6	26.	99.1837.00		Screw	5	48.	96.7380.00		Washer	1
7.	94.7376.00	123	Spring	6	27.	90.3585.00		O-Ring	1	49.	96.7514.00		Washer	1
8.	36.2025.51	123	Valve Cage	6	28.	98.2041.00		Cap Screw	1	75	90.0635.00		Retaining Ring	1
9.	90.3847.00	124	O-Ring	6	29.	97.7340.00		Pin	3	*76.	44.0212.65		Crankshaft	1
10.	98.2226.00	124	Cap	6	30.	96.7350.00		Washer	3	77.	91.8568.00		Roller Bearing	1
11.	36.7115.01	123	Valve Assembly	6	31.	90.5022.00		Anti-Ext. Ring	3	78.	91.4097.00		O-Ring	1
12.	99.1807.00		Screw	8	32.	90.3572.00		O-Ring	3	79.	99.2755.00		Screw	4
13.	50.1500.74		Bearing Cover	2	33.	52.0400.09		Piston	3	80.	96.7020.00		Washer	4
14.	44.2118.01		Spacer	1	34.	96.7008.00		Washer	3	81.	10.0518.22		Gas Flange	1
15.	90.4097.00		O-Ring	1	35.	92.2216.00		Nut	3	82.	90.1690.00		Oil Seal	1
16.	91.8328.00		Ball Bearing	2	40.	90.3612.00	125,130	O-Ring	3	83.	96.6938.00		Washer	4
17.	90.1614.00	123	Oil Seal	3	41.	44.0800.70	125,130	Packing Retainer	3	84.	99.1912.00		Screw	4
18.	44.0100.22		Crankcase	1	42.	52.2166.70	89,130	Intermed. Ring	3					

*76 44.0220.65 Crankshaft for 3000.5

REPAIR KITS

KIT NO.	88	89	90	123	124	125	130
ITEM NO'S INCLUDED IN KIT	43, 44	42	45	4, 5, 6, 7, 8, 17 (11)	9, 10	40, 41	40, 41, 42, 43, 44, 45
NUMBER OF ASSEMBLIES IN KIT	3/6	3	6	6	6	3	1/2
NUMBER OF CYLINDERS KIT WILL COVER	3	3	3	3	3	3	1

TORQUE SPECS

Position	Ft./lbs.
2	14.7
10	73.7
12	7.3
26	7.3
28	14.7
35	11.0
46	29.4
47	29.4
79	14.7
84	7.3



HIGH PRESSURE PUMP

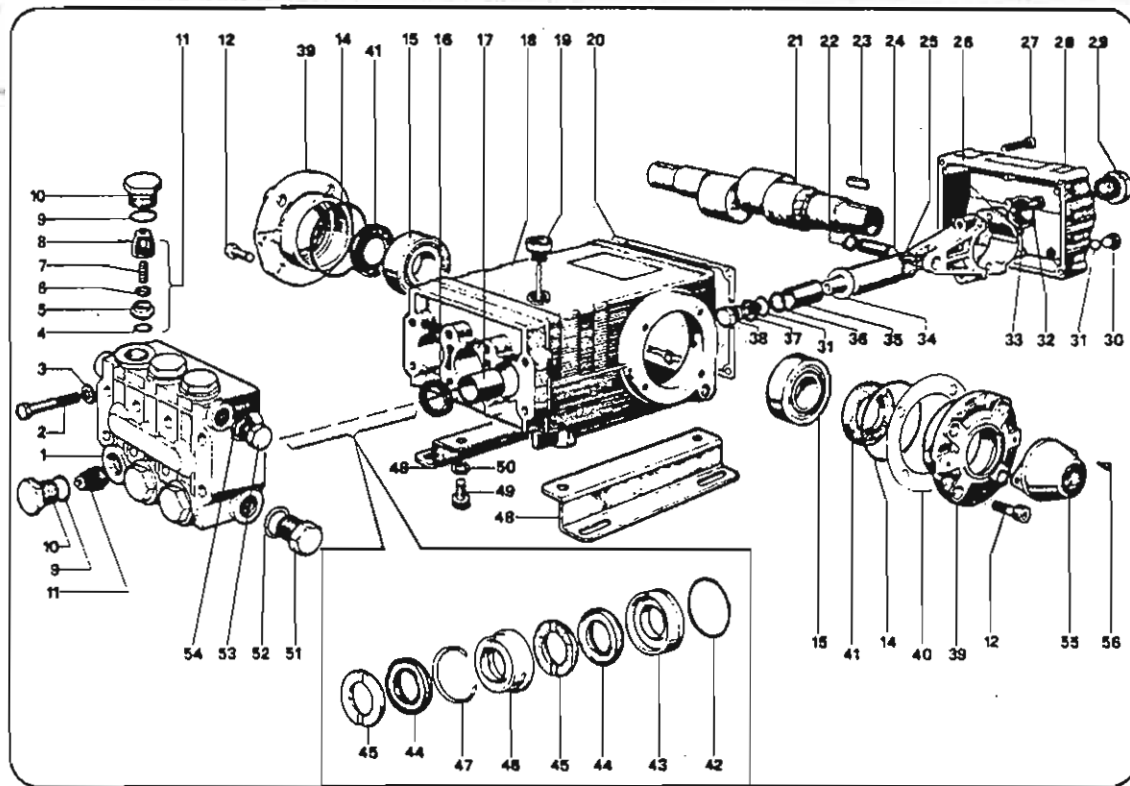

No.	Description	Part No.	No.	Description	Part No.
1.	Pump Head T9211 + TS2021 TS1011 + TS1511	47.1209.41 47.1208.41	27.	Screws (5) TS1511 + TS2021 + T9211 TS1011	99.1912.00 99.1837.00
2.	Screws (8)	99.3206.00	28.	Crankcase Cover TS1511 + TS2021 + T9211 TS1011	47.1604.22 47.1603.22
3.	Washers (8)	96.7020.00	29.	Oil Level Indicator	97.5968.00
4.	O Rings (6)	Kit 1 90.3841.00	30.	Cap	98.2041.00
5.	Valve Seats (6)	Kit 1 36.2003.66	31.	O Rings (4)	Kit 6 90.3585.00
6.	Valve Plates (6)	Kit 1 36.2001.76	32.	Screws (6)	99.3099.00
7.	Springs (6)	Kit 1 94.7376.00	33.	Washers (6)	96.7014.00
8.	Valve Guides (6)	Kit 1 36.2002.51	34.	Washers (3)	96.7286.00
9.	O Rings (6)	Kit 4 90.3847.00	35.	Pistons (3)	47.0404.09
10.	Caps (6)	Kit 4 98.2222.00	36.	Anti-extrusion Rings (3)	Kit 6 90.5067.00
11.	Valve Assembly (6)	Kit 1 36.7032.01	37.	Washers (3)	Kit 6 96.7280.00
12.	Screws (8)	99.3039.00	38.	Piston Screws (3)	Kit 6 47.2195.66
13.	Crankcase Closed Cover	47.1505.22	39.	Crankcase Open Cover	47.1503.22
14.	O Rings (2)	90.3913.00	40.	Shims (2)	97.5678.00
15.	Tapered Roller Bearings (2) T9211 + TS2021 91.8377.00 TS1011 + TS1511 91.8375.00		41.	Oil Seals	Kit 3 90.1648.00
16.	Oil Seals (3)	90.1625.00	42.	O Rings (3)	Kit 10, 28 90.3616.00
17.	Bushings (3)	90.9126.00	43.	Packing Retainers (3)	Kit 10, 28 47.0805.70
18.	Crankcase TS2021 47.0105.22 T9211 + TS1511 + TS1011 47.0104.22		44.	Packings (6)	Kit 8, 28 90.2705.00
19.	Oil Dip Stick	98.2106.00	45.	Head Rings (6)	Kit 7, 28 47.1000.51
20.	Cover Gasket	47.2119.84	46.	Intermediate Rings (3)	Kit 9, 28 47.2166.70
21.	Crankshaft (USA Version) TS1511 + TS1011 47.0218.35 TS2021 47.0217.35 T9211 47.0219.35		47.	"Long Life Rings" (3)	Kit 9, 28 90.5182.00
22.	Snap Rings (6)	90.0557.00	48.	Pump Feet (2)	47.2000.74
23.	Key	91.4878.00	49.	Screws (4)	99.3644.00
24.	Wrist Pins (3)	97.7380.00	50.	Washers (4)	96.7106.00
25.	Piston Guides (3)	47.0503.56	51.	Cap	98.2176.00
26.	Connecting Rods (3)	47.0300.01	52.	Washer	96.7514.00
			53.	Cap	98.2100.00
			54.	Washer	96.7380.00

REPAIR KITS

TS-1511, TS-2021, TS-1011, T-9211

KIT NO.	1	2	3	4	6	7	8	9	10	28
	VALVE ASSEMBLY	PISTON OIL SEAL	CRANKSHAFT OIL SEAL	VALVE CAP ASSEMBLY	PISTON RETAINER	HEAD RING	PACKING	INTERMEDIATE RING	PACKING RETAINER	PACKING ASSEMBLY
ASSEMBLY (Pos. No.)	4, 5, 6, 7, 8	16	41	9, 10	31, 36, 37, 38	45	44	46, 47	42, 43	42, 43, 44, 45, 46, 47
NO. OF ASSEMBLIES	6	3	2	6	3	6	6	3	3	1

REGULATOR UNLOADER

K5.1	MODEL	PWD 3000.3.5	
	PART NO.	192-001	
K5.2	MODEL	PWD 2500-5	PWD3000-6
	PART NO.	168-001	169-001

1	Spring	Kit 58-60	94.7374.00
2	Valve	Kit 58-60	36.3008.66
3	Control Rod	Kit 60	36.3030.66
4	Seat Insert	Kit 58-60	36.3034.66
5	Piston	Kit 58-60	36.3032.70
6	Spring	Kit 58-60	94.7430.00
7	Spring Plate	Kit 60	36.3031.70
8	O-Ring	Kit 58	90.3572.00
9	Pressure Gauge	Not Included	
10	Caps (2)		98.2041.00
11	Unloader Body		36.3028.41
12	Pressure Adjusting Screw		36.3001.64
13	Nut		92.2560.00
14	O-Ring		90.3823.00
15	Nozzle		
	K5.1		10.0077.66
	K5.2		10.0162.66
	K5.3		10.0163.66
16	O-ring		90.3833.00
17	Nipple	Kit 58	
	K5.1		10.0078.70
	K5.2		10.0160.70
	K5.3		10.0161.70
18	O-Ring	Kit 58	90.3845.00
19	Rod Guide		36.3029.70
20	Compression Rings (4)	Kit 58-60	92.7722.00
21	Retaining Ring	Kit 58-60	90.0509.00
22	O-Ring	Kit 58-60	90.3859.00
23	Nut	Kit 58-60	92.1925.00
24	Valve Seat	Kit 60	36.3050.70
25	Ring Nut	Kit 58-60	36.3035.70

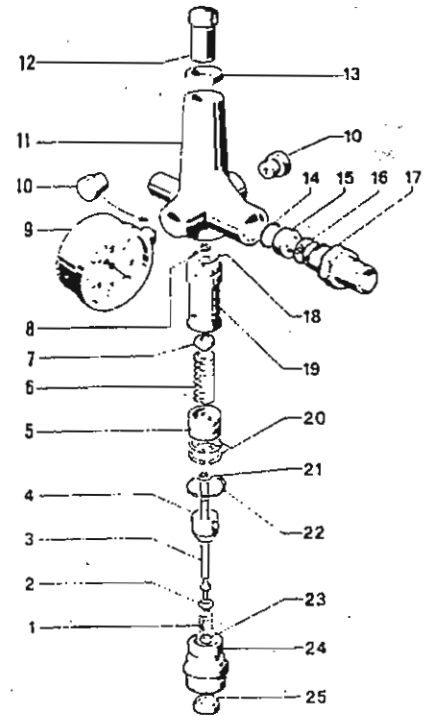

GEAR REDUCER GR 1000

NO.	DESCRIPTION	PART NO.
1.	Oil Seal.....	90.1680.00
2.	Screws (9).....	99.3084.00
3.	Washers (13).....	96.7014.00
3.	Washers (4).....	96.7104.00
4.	Cap.....	98.2100.00
5.	O Ring.....	90.3833.00
6.	Reducer Box.....	10.0229.22
7.	Retaining Ring.....	90.0725.00
8.	Ball Bearing.....	91.8518.00
9.	Retaining Ring.....	90.0976.00
11.	Pinion Gear 1 1/2 Bore ..	10.0271.55
12.	Ring Gear.....	10.0234.55
13.	Screw.....	99.3017.00
14.	Gasket.....	10.0232.84
15.	Flange Adapter.....	10.0230.22
16.	O Ring.....	90.3898.00
17.	Gaskets (4).....	93.1754.00
18.	Screws (4).....	99.3085.00
19.	Oil Dip Stick.....	98.2106.00
20.	Screws (4).....	99.2755.00
20.	Screws (4).....	99.3345.00
21.	Washers (4).....	96.7020.00
22.	Oil Level Indicator.....	97.5968.00

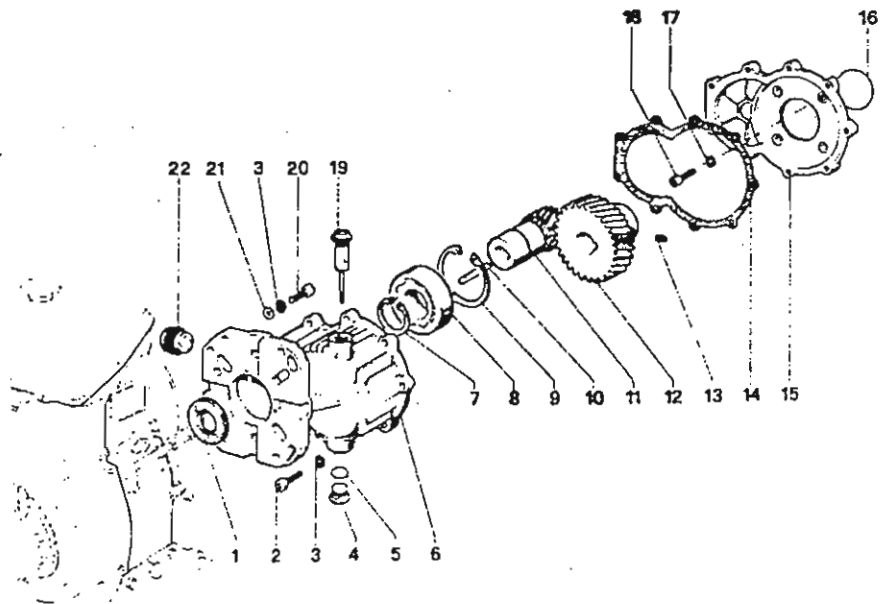

PARTS LIST - FRAME

ITEM	PART NO.	QTY	DESCRIPTION	ITEM	PART NO.	QTY	DESCRIPTION
1	171-018	1	Frame	16	171-031	1	Hook
2	143-008	2	Rivnut	17	171-025	1	Bracket
3	*	1	Axle	18	172-032	1	Bracket Unloader
4	169-028	2	Wheel	19	171-020	4	Grommet
5	171-024	2	Rivnut	20	260-030	2	Nut - Self Lock
6	171-026	2	Tube Cap	21	163-011	2	Washer, Flat
7	*	*	Spacer	22	140-029	2	Washer, Flat
8	*	*	Spacer	23	113-023	2	Washer Lock
9	136-095	2	Hose Bracket	24	136-126A	2	Pan H Screw
10	143-029	2	Set Collar	25	136-123	2	Screw
11	143-030	2	Set Screw	26	188-185	2	Spacer
12	140-047	4	Washer Flat	27	113-023	2	Washer Lock
13	140-048	4	Washer Lock	28	140-029	2	Washer Flat
14	163-008	2	Rubber Foot	29	*	1	Tube Axle
15	163-019	2	Pan H Screw	30	169-049	2	Wheel Bearing

ITEM	ENGINE	QTY	PART NO.	DESCRIPTION
3	Briggs /Wisconsin	1	136-088	Axle
	Honda/Briggs 18	1	171-030	Axle
7	Honda	1	171-039	Spacer
	Briggs/Wisconsin	2	171-040	Spacer
	Briggs 18 HP	1	171-040	Spacer
8	Honda	1	171-040	Spacer
	Briggs Wisconsin	2	171-040	Spacer
	Briggs 18 HP	1	171-039	Spacer
29	Honda/Briggs 18	1	171-035	Tube Axle
	Briggs Wisconsin	1	171-036	Tube Axle

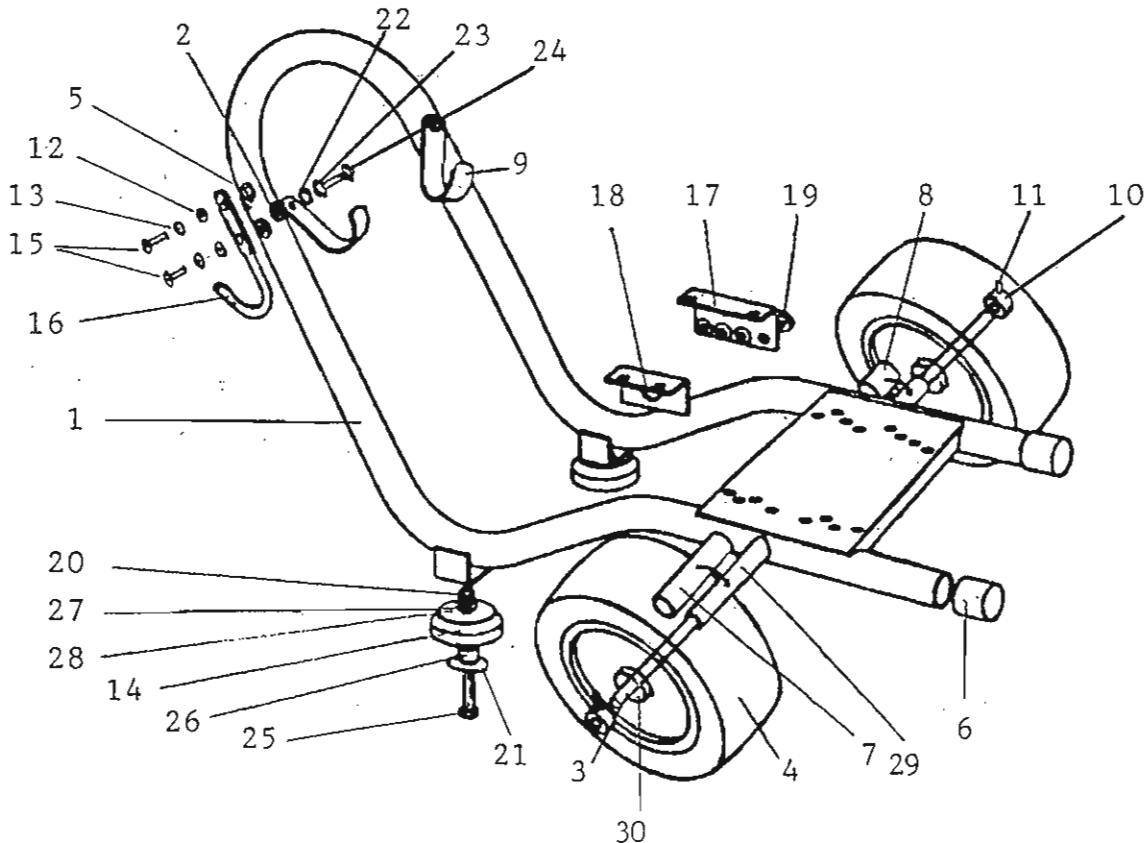

DOWNSTREAM CHEMICAL INJECTORS

FEATURES

- 1) Streamline your combination injector/quick disconnect assembly with this latest one piece style design.
- 2) Brass Construction with stainless steel ball.
- 3) Inconel Spring
- 4) Built in 3/8 socket and 3/8 plug available with inlet or discharge on plug side of assembly.

Item No.	Part No.	Description & no.reqd.
1	7219	Snap Ring (1)
2	7087D2	Ball (9)
3	7201	Sleeve (1)
4	7199	Spring (1)
5 **	7109D40	O Ring (1)
6	7268	Orifice #3 (1)
7	7488	Jam Nut (1)
8	7487	Retainer, Barb (1)
9	7486	Adjusting Barb (1)
10 **	7109D22	O Ring (1)
11 **	7087D6	Ball (1)
12 **	5037D5	Spring (1)
13	7524	Body (1)
14 **	7109D28	O-Ring (1)

** INDICATES ITEMS IN REPAIR KIT 7525K

AIRLESSCO PART NO. USE ON MODEL NO.

176-030B	Adj. Chem Inj.	PWD 3000 3.5 PWD 2000-4 PWD 2500-5
176-030C	Adj. Chem Inj.	PWD 3000-6

REPAIR KIT

176-030-050 Chem. Inj. Repair Kit 7525K
Use chemical injectors in conjunction with nozzle 78-40300.

OPERATING INSTRUCTIONS

Fit chemical injector on downstream side of pump and regulator. Connect chemical injector to lance, open valve on injector and operate. Wash from the bottom up and rinse from the top down. Clean injector after use by sucking clean water through the injector. DO NOT USE WITH PAINTS OR ACIDS.

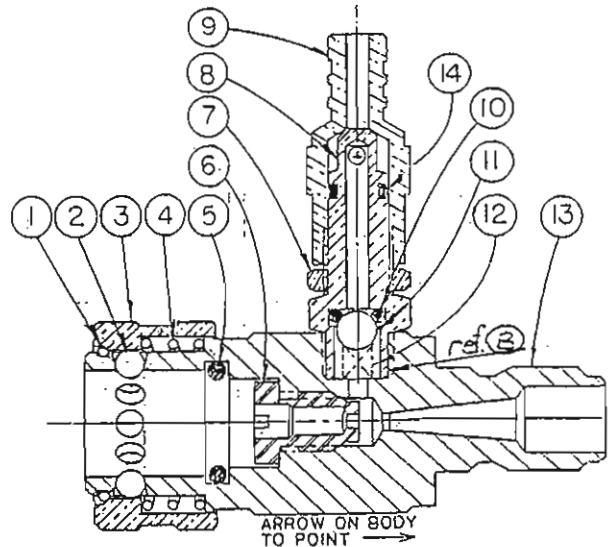
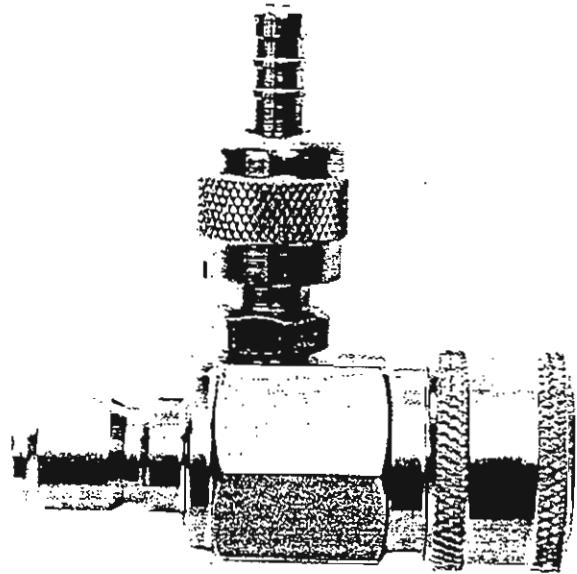

ref. B APPLY LOCTITE #242
TORQUE TO 100 IN. LB.

SANDBLAST KIT Part No. 176-040

For suction fed injection of sand into the water stream for abrasive cleaning.
(High pressure spray tip not included.)

SPECIFICATIONS

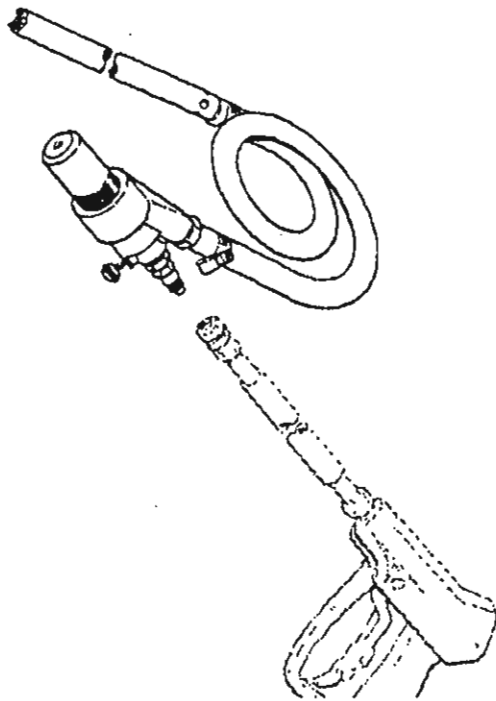

Part Number

Maximum Pressure 3500 PSI (241 bar)

Maximum Temperature 200° F (93° C)

Weight 13 lb. (5.9 kg)

Material Plated Carbon Steel, Aluminum, Carbide, Rubber.

PARTS DRAWING

PARTS LIST

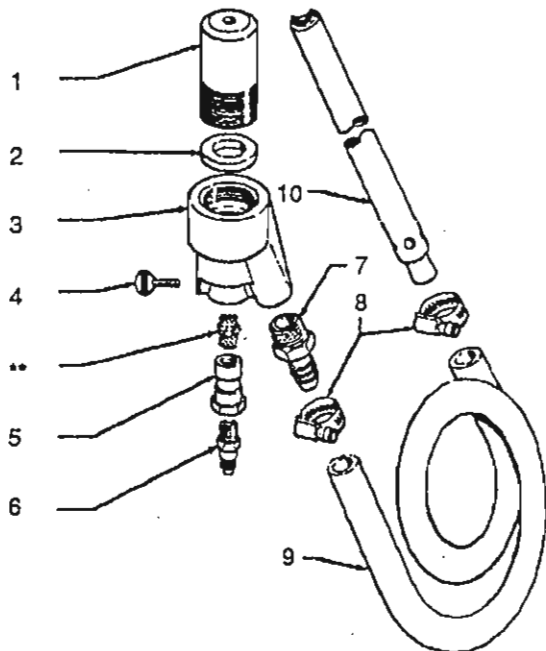

10200001 SANDBLASTING KIT COMPLETE **

NO.	PART NO.	DESCRIPTION	QTY.
1.	103202	Nozzle, Sand	1
2.	700005	Gasket	1
3.	103201	Housing, Mixing Head	1
4.	202003	Thumbscrew	1
5.	530010	Adapter, Tip	1
6.	176-006	Coupler, Male, Quick Disconnect	1
7.	680001	Hosebarb	1
8.	176-018	Hose Clamp	2
9.	176-016	Hose, Sand	1
10.	176-017	Probe, Sand	1

Gun, Wand not included
(A 15° spray angle spray tip of the appropriate orifice size for your equipment must be used for proper operation.)

Sept.20/91 001-243

WARNING - High Pressure Spray can cause extremely serious injury. Treat as you would a loaded firearm! Read & understand all warnings and instructions before operating equipment. Never Point Gun at anyone or at any part of the body. Never put hand or fingers over nozzle. Always be sure work area is away from other people. Post warning signs- SANDBLASTING IN PROGRESS and rope off the area.

**ALWAYS WEAR GOGGLES, FACE SHIELD OR HOOD AT ALL TIMES FOR YOUR SAFETY.
ALWAYS WEAR HEAVY GLOVES THAT WILL PROTECT HANDS AND ARMS.**

OPERATION

1. Place the sand induction probe in the sand supply container.
2. Connect and open the water supply line before starting the unit.
3. Trigger the gun to relieve air in the equipment.
4. Start the unit.
5. Trigger the gun to activate the spray.

CAUTION: Always test spray on a scrap of similar material first! The high pressure spray could damage the surface if the sandblaster is held too close. See Step 5 below.

6. Check the distance you will need to hold the spray nozzle from the surface by starting to spray at the scrap of material from a distance of several feet. *Gradually* move closer, checking frequently to see if the high pressure spray is damaging the surface.
7. See Application section for the type of sand recommended for your work surface.

NOTES: Always point the sand nozzle downward when not spraying. This will prevent water from entering the sand supply. If water does get into the sand supply hose remove the probe from the sand, hold gun trigger open, and let the hose air dry. Always be sure sand hose is dry before using.

- * Keep the sand covered to prevent the overspray from wetting the sand.
- * Do not allow small fragments of sand bags to fall into the sand supply. A small paper fragment could prevent flow of sand.

SHUTDOWN

After sandblasting operation is complete, remove the probe from the sand, trigger the gun to clear the hose and probe of sand. Then, remove the hose from the mixing head and rinse with water to remove all the sand before storage.

Before using the gun for other applications be sure to reinstall the tip guard, tip, nozzle and male quick coupler.

APPLICATION

SAND USAGE: with 2500 PSI- 5 GPM, 9 lb. per min.

Removal of:	Sand Mesh	Sand Type	Blasting Angle
Paint from Metal	20/40	Round Silica	0 - 30 degrees
Paint from Masonry	20/40	Round Silica	0 - 20 degrees
Rubber Base Paint from Masonry	10/35	Angular	0 - 15 degrees
Paint from Wood (Coarse, rough cut effect)	40/60	Round	1 - 10 degrees
Paint from Wood (Smoother Drift wood effect)	20/40	Round	1 - 10 degrees
Metal Scale	20/40	Round	0 - 15 degrees
Rust	16/50	Angular	0 - 25 degrees

TROUBLESHOOTING

NO SAND

- Plugged sand probe-Clear obstruction
- Plugged Gun Inspect mixing chamber
- Wet Sand Dry or replace sand
- Low vacuum Air leaks in system.

NOT ENOUGH SAND

- Incorrect water nozzle Change to 15 deg. nozzle.
- Collapsed Hose. Replace hose /remove restriction.
- Partial Obstruction to probe. Clear rocks or paper from probe inlet.
- Low Sand Level Change probe to new bag of sand.

PROCEDURE FOR SERVICING PUMPS

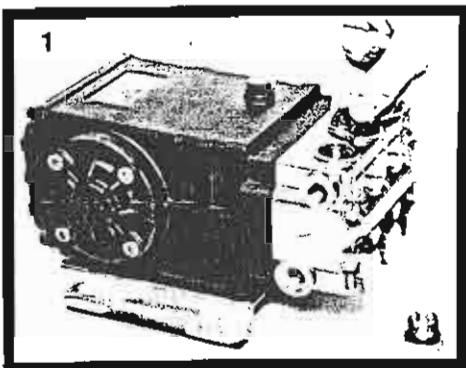

The Valve Assemblies

Photo 1

- 1) All inlet and discharge valves can be serviced without disrupting the inlet or discharge plumbing. The inlet and discharge valves are the identical in all models.
- 2) To service any valve, remove valve cap and extract valve assembly.
- 3) Examine o-rings and replace if there is any evidence of cuts, abrasions, or distortion.
- 4) Remove valve assembly (retainer, spring, valve, valve seat) from valve cavity.
- 5) Remove o-ring from valve cavity.
- 6) Only one valve kit is necessary to repair all the valves in the pump. The kit includes new o-rings, valve seat, poppet, spring and retainer, all pre-assembled.
- 7) Install new o-ring in valve cavity.
- 8) Insert assembly into valve cavity.
- 9) Replace valve cap and torque to specifications.

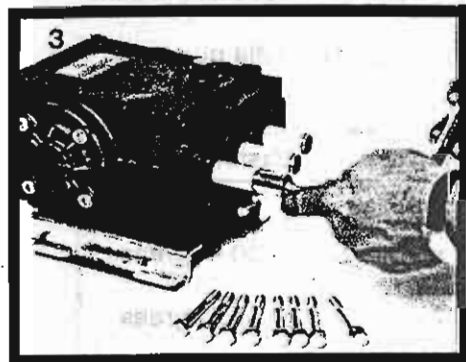
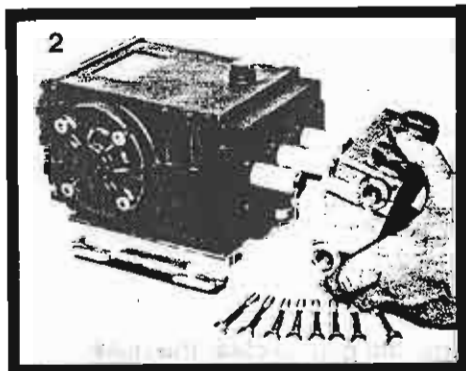

Removing Manifold Head

Photo 2

- 1) Remove the fasteners retaining head.
- 2) Separate head from crankcase. NOTE: It may be necessary to tap head lightly with rawhide mallet to loosen. CAUTION: When sliding head from crankcase use caution not to damage plungers.
- 3) The V-packing assemblies may come off with the head. At this point, examine plungers. Plunger surfaces should be smooth and free from scoring or pitting; if not, replace.
- 4) Reinstall manifold head and torque to specifications per sequence described below.

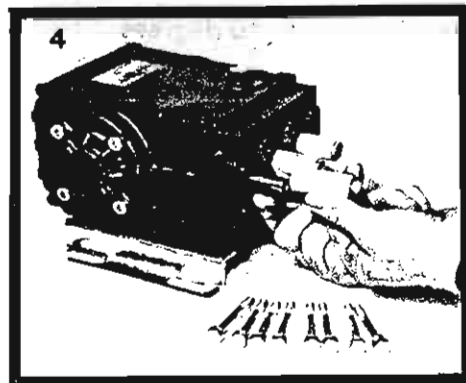

TORQUE SEQUENCE FOR TIGHTENING HEAD

Install all head bolts fingertight. Torque to 10 foot pounds in sequence as shown, then retorque to specifications, again, in sequence shown.

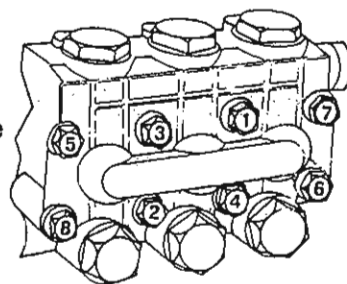

Replacing Plungers

Photo 3, 4 and 5

- 1) Remove stainless steel piston screw and plunger from piston rod.
 - 2) If slinger washer comes off with plunger, be certain this is replaced before new plunger is installed.
 - 3) Separate piston screw from plunger.
 - 4) Install new o-ring and teflon backup-ring on piston screw.
- NOTE: A film of grease on the outside of the o-rings insures a better installation.
- 5) Carefully press piston screw into plunger.
 - 6) Slide new plunger over the piston guide and torque to specifications.

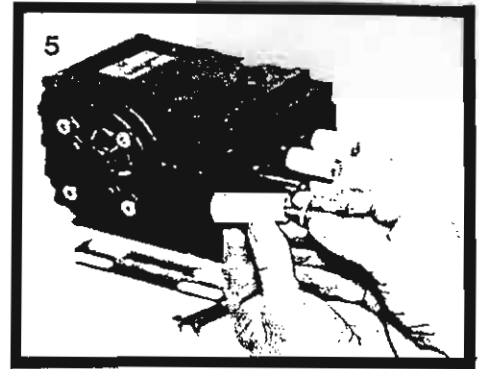

Replacing V-Packings

Photo 6, 7, 8 and 9

- 1) Remove manifold from crankcase.
- 2) Insert proper extractor collet through main seal retainer. Tighten collet and extract retainers, v-packings and head rings.
- 3) Place proper insertion tool in cylinder and install front head ring, v-packing and long life ring and press firmly into cylinder until they will go no further using proper insertion tool.
- 4) Insert intermediate seal retainer, pressing it firmly into cylinder until it will go no further using proper insertion tool. Install rear head ring, v-packing and main seal retainer into cylinder in order shown and press firmly into cylinder.
- 5) Repeat this sequence for each cylinder.
- 6) Coat each plunger with grease and carefully remount manifold. Torque head to specifications.

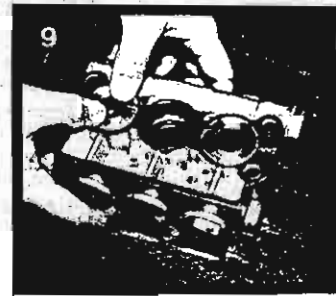
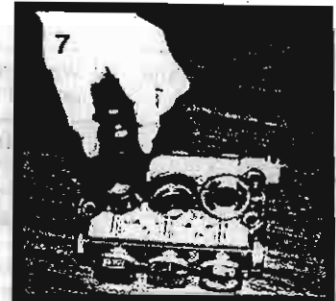
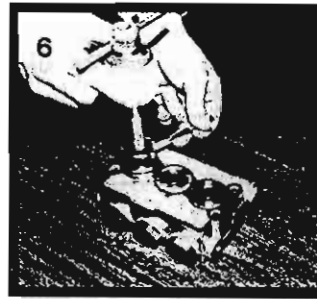

TYPICAL GENERAL PUMP
PACKING CROSS SECTION

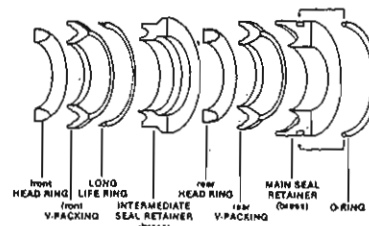

TROUBLE SHOOTING

PROBLEM	CAUSE	REMEDY
Pulsation	Faulty pulsation damper.	Check precharge; if low, recharge it or install a new one.
Low Pressure	Worn nozzle.	Replace nozzle, of proper size.
	Belt slippage.	Tighten or replace; use correct belt.
	Air leak in inlet plumbing.	Disassemble, reseal and reassemble.
	Relief valve stuck, partially plugged or improperly adjusted valve seat worn.	Clean, adjust relief valve; check for worn and dirty valve seats. Kit available.
	Inlet suction strainer clogged or improperly sized.	Clean. Use adequate size. Check more frequently.
	Worn packing. Abrasives in pumped fluid or severe cavitation. Inadequate water.	Install proper filter. Suction at inlet manifold must be limited to lifting less than 20 feet of water or -8.5 PSI vacume.
	Fouled or dirty inlet or discharge valves.	Clean inlet and discharge valve assemblies.
	Worn inlet, discharge valve blocked or dirty. Leaky discharge hose.	Replace worn valves, valve seats and/or discharge hose.
Pump runs extremely rough, pressure very low	Restricted inlet or air entering the inlet plumbing.	Proper size inlet plumbing; check for air tight seal.
	Inlet restrictions and/or air leaks. Stuck inlet or discharge valve.	Replace worn cup or cups, clean out foreign material, replace worn valves.
Water leakage from under manifold. *Slight Leakage	Worn packing.	Install new packing.
Oil leak between crankcase and pumping section.	Worn crankcase piston rod seals O-rings on plunger retainer worn.	Replace crankcase piston rod seals. Replace O-rings.
Oil leaking in the area of crankshaft.	Worn crankshaft seal or improperly installed oil seal-O-ring.	Remove oil seal retainer and replace damaged O-ring and/or seals.
	Bad bearing.	Replace bearing.
Excessive play in the end of the crankshaft pulley.	Worn main bearing from excessive tension on drive belt.	Replace crankcase bearing and/or tension drive belt.
Water in crankcase.	May be caused by humid air condensing into water inside the crankcase.	Change oil intervals. Use any high grade automotive 30 weight nondetergent oil.
	Worn packing and/or piston rod sleeve, O-rings on plunger retainer worn.	Replace packing. Replace O-rings.
Oil leaking from underside of crankcase.	Worn crankcase piston rod seals.	Replace seals.
Oil leaking at the rear portion of the crankcase.	Damaged crankcase, rear cover O-ring, drain plug O-ring; or sight glass O-ring.	Replace cover O-ring, drain plug O-ring, or sight glass O-ring.
Loud knocking noise in pump.	Pulley loose on crankshaft.	Check key and tighten set screw.
	Broken or worn bearing.	Replace bearing.
Frequent or premature failure of the packing.	Scored, damaged or worn plunger.	Replace plungers.
	Overpressure to inlet manifold.	Reduce inlet pressure.
	Abrasive material in the fluid being pumped.	Install proper filtration on pump inlet plumbing.
	Excessive pressure and/or temperature of fluid being pumped.	Check pressures and fluid inlet temperature; be sure they are with in specified range.
	Over pressure of pumps.	Reduce pressure.
	Running pump dry.	Do not run pump without water.