

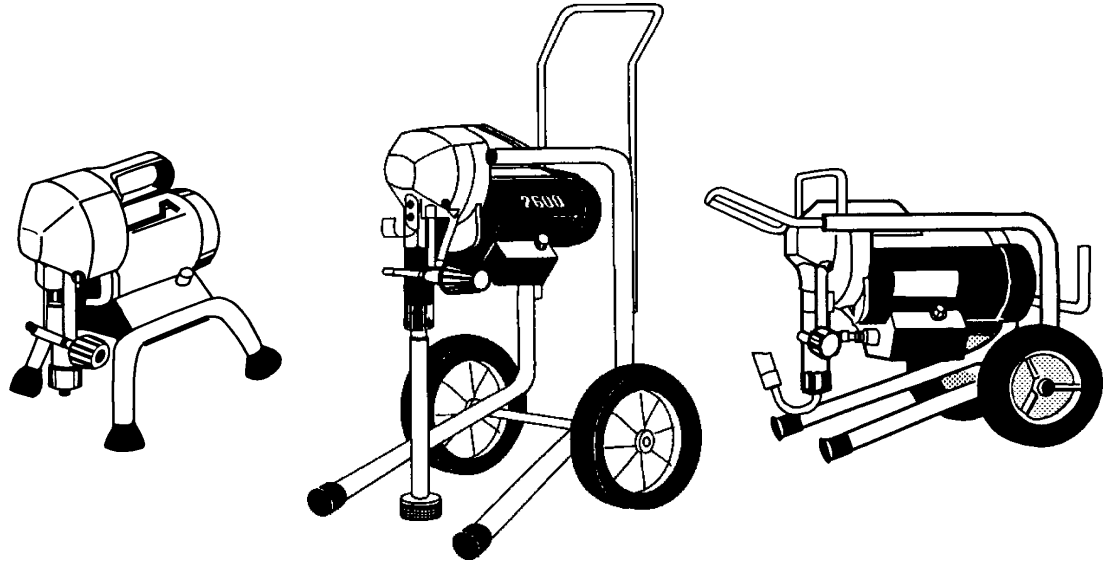

LP SERIES

AIRLESS PAINT SPRAYER



OPERATION MANUAL AND PARTS LIST

**Models LP 2400, LP 2500
LP 2600 Hi-Boy and LP 2600 Lo-Boy**

WARNING !!

HANDLE THIS UNIT AS YOU WOULD A LOADED FIREARM!
The high pressure spray can cause extremely serious injury.
OBSERVE ALL WARNINGS!

Before operating this unit, read and follow all safety warnings and instructions related to the usage of this equipment. **READ, LEARN** and **FOLLOW** the Pressure Relief Procedure on Page 6 of this manual.

All Service Procedures to be performed by Authorized Airlessco Service Center **ONLY**.

NO MODIFICATIONS or alterations of any AIRLESSCO Equipment or any AIRLESSCO part is allowed.

AIRLESSCO BY DUROTECH CO.

P.O. Box 8006, Moorpark, CA. 93020-8006, Ship to: 5397 Commerce Ave., Moorpark, CA 93021

Tel: 805-523-0211 Fax: 805-523-1063

SUBJECT TO CHANGE WITHOUT NOTICE.

FORM NO. 001-428, May 99

U.S. PATENT NO. 4775303. OTHER US & FOREIGN PATENTS APPLIED FOR.

TABLE OF CONTENTS

Introduction	1
Flushing	1
How to Flush	2
Setting Up	3
Starting Up	3, 4
Warnings- Read prior to using sprayer	4, 5, 6, 7
PRESSURE RELIEF PROCEDURE	6
Airlessco 007 Spray Gun Components	8
Spray Tip Selection	9
Spray Technique	10, 11
Airlessco 007X and 007XL Parts Lists	12, 13
Airless Spray Gun Troubleshooting	14
Regular Maintenance	15
Electric Motor Maintenance	15
Troubleshooting	16
Troubleshooting- Machine Does not Start	17
Pressure Control Assembly	18
Electrical System	19
Replacement of Electrical Components	20
Servicing the Fluid Pump	21
Gear and Pump Assembly	22
Servicing Piston Rod, Upper Check Valve	22
Servicing Lower Suction Valve	23
V-Packing Replacement	24
Fluid Pump	25
2400 / 2500 Complete Machine Parts List	26
2600 Lo-Boy Complete Machine Parts List	27
2600 Hi-Boy Frame	28
Suction Assemblies	29

INTRODUCTION

AIRLESSCO'S DC POWERED LP SERIES

The LP Series are compact, lightweight, airless paint sprayers built to meet the needs of the beginning and the experienced painting contractor.

Specifications

	LP2400	LP2500	LP2600 (Hi-Boy & Lo-Boy)
Pressure	3000 psi	3000 psi	3000 psi
Output	0.4 gpm	0.5 gpm	0.6 gpm
Tip Size	1 gun up to 0.019	1 gun up to 0.021	1 gun up to 0.023
Motor	DC TEFC .5 hp	DC. TEFC. .75 hp	DC. TEFC. .75 hp
Weight	38 lbs.	41 lbs.	65 lbs.

WARNING

Prior to starting, read, understand and observe all safety precautions and warnings on cover & pages 4, 5, 6, 7 and all labels and tags on the machine

Learn how to relieve pressure by following Pressure Relief Procedure on page 6 before operating this machine.

FLUSHING Read prior to using your sprayer

1. New Sprayer

Your Airlessco unit was factory tested in an anti-freeze solution which was left in the pump. **Before using oil-base paint**, flush with mineral spirits only. **Before using water-base paint** flush with mineral spirits, followed by soapy water, then a clean water flush.

2. Changing Colors

Flush with a compatible solvent such as mineral spirits or water.

3. Changing from water-base to oil-base paint.

Flush with soapy water, then mineral spirits.

4. Changing from oil-base to water-base paint.

Flush with mineral spirits, followed by soapy water, then a clean water flush.

5. Storage

Always relieve pressure (See pressure relief procedure on page 6) prior to storage or when machine is unattended.

Oil-base Paint: Flush with mineral spirits. Ensure that there is no pressure in the unit, then close the prime/pressure relief valve.

Water-base Paint: Flush with water, then mineral spirits. For longer term storage use a 50/50 mixture of mineral spirits and motor oil. Always ensure that there is no pressure in the unit, and close the prime/pressure relief valve for storage.

WARNING - NEVER LEAVE PUMP UNATTENDED WHILE UNDER PRESSURE!

6. Start up after Storage

Before using water-base paint, flush with soapy water and then a clean water flush.

When using oil-base paint, flush out the mineral spirits with the material to be sprayed.

HOW TO FLUSH

FIGURE 1

Prime/Pressure Relief Valve (Prime/PR Valve)
Used to relieve pressure from gun, hose & tip and to prime the unit when in OPEN position. (It is in open position when there is a wider gap between valve handle and cam body).

When in CLOSED position, there is only a very slight gap between handle & body. When closed the system is pressurized. Handle as a loaded firearm!

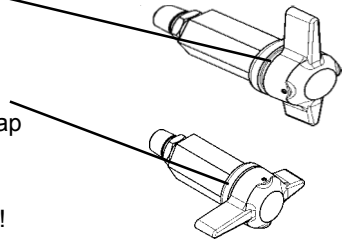

PRIME/PRESSURE (PR) RELIEF VALVE (FIG. 1) is used to prime pump and to relieve pressure from gun, hose and tip.

FIGURE 2

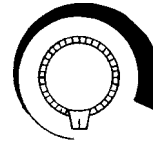

PRESSURE CONTROL KNOB. (FIG. 2) is used to adjust pressure. Turn clockwise (CW) to increase pressure and counterclockwise (CCW) to decrease pressure.

FIGURE 3

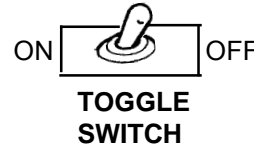

1. Be sure the gun safety latch is engaged and there is no spray tip in the gun. Refer to separate gun instruction manual on how to lock the safety latch and the gun's safety features. Refer to Figure 4 and Page 8 for Airlessco 007 Gun.

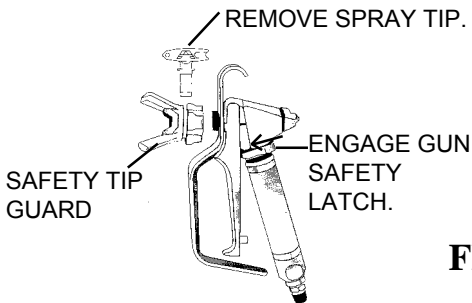

FIGURE 4

2. Pour enough clean, compatible solvent into a large, empty metal pail to fill the pump and hoses.
3. Place the suction tube into the pail.
4. Turn the Prime/Pressure Relief (PR) Valve to the "OPEN", priming position. Refer to Fig. 1.

5. Point the gun into the metal pail and hold a metal part of the gun firmly against the pail. Refer to Fig. 5.
6. Disengage the gun safety latch and squeeze the gun trigger. Turn the ON-OFF Toggle Switch to the "ON" position (Fig. 3) and turn Pressure Control Knob (Fig. 2) clockwise to increase pressure just enough to start the pump.
7. Turn the Prime/PR Valve to the PRESSURE - "CLOSED" position. This will allow solvent to be flushed through the pump, hoses and gun. Allow the unit to operate until clean solvent comes from the gun.
8. Release the trigger and engage the gun safety latch.
9. If you are going to start spraying, place the suction tube into the supply container. Release the gun safety latch and trigger the gun into another empty, metal container, holding a metal part of the gun firmly against the metal pail and force the solvent from the pump and hose. Engage the gun safety latch until you are ready to spray.
10. If you are going to store the sprayer, remove the suction tube from the solvent pail, holding a metal part of the gun firmly against the metal pail and force the solvent from the pump and hose. Engage the gun safety latch. Refer to "Storage" Procedure on Page 1.
11. Whenever you shut off the sprayer, follow the "PRESSURE RELIEF PROCEDURE" on Page 6.

WARNING - To reduce the risk of static sparking which can cause fire or explosion, always hold a metal part of the gun firmly against the metal pail when flushing. This also reduces splashing. Refer to Fig. 5.

FIGURE 5
MAINTAIN FIRM METAL TO METAL CONTACT BETWEEN GUN AND CONTAINER



SETTING UP

1. Connect the hose and gun.

- Remove the plastic cap plug from the outlet tee and screw a conductive or grounded 3000 psi airless spray hose onto fluid outlet.
- Connect an airless spray gun to the other end of the hose.
- Do not use steel braided airless hose. Use nylon braided airless hose only.

NOTE: Do not use thread sealer on swivel unions as they are made to self-seal. Use thread seal on tapered male threads only.

2. Fill the Packing Nut/Wet Cup 1/3 full with Throat Seal Oil (TSO) supplied.

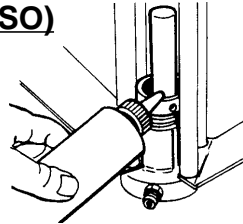

FIGURE 6

3. Check the Electrical Service.

Be sure the electrical service is 120 VAC, 15 amp minimum, and that the outlet you use is properly grounded.

4. Grounding

WARNING - To reduce the risk of static sparking, fire or explosion which can result in serious bodily injury and property damage, always ground the sprayer and system components and the object being sprayed as instructed on Page 6.

5. Flush the sprayer as per "Flushing - New Sprayer" on page 1 and "How to Flush on page 2.

STARTING UP

1. Learn the functions of the controls.

PRIME/PRESSURE (PR) RELIEF VALVE is used to prime pump and to relieve pressure from gun, hose and tip.

FIGURE 7

Prime/Pressure Relief Valve (Prime/PR Valve)
Used to relieve pressure from gun, hose & tip and to prime the unit when in "OPEN" position. (It is in open position when there is a wider gap between valve handle and cam body).

When in CLOSED position, there is only a very slight gap between handle & body. When closed the system is pressurized. Handle as a loaded firearm!

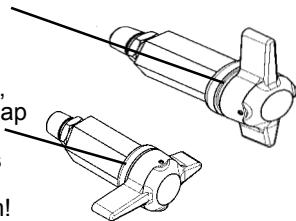

FIGURE 8

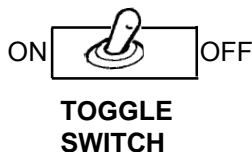
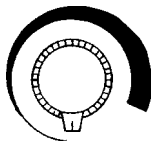

FIGURE 9

PRESSURE CONTROL KNOB

is used to adjust pressure. Turn clockwise (CW) to increase pressure and counterclockwise (CCW) to decrease pressure.



2. Prepare the Material

- Prepare the material according to the material manufacturer's recommendations.
- Place the suction tube into the material container.

3. Starting the Sprayer (See Fig. 7,8 & 9)

- Prime/PR Valve must be "OPEN" in the priming position.
- When you have ensured that the gun safety latch is engaged, attach tip and Safety Guard.
- Turn the ON-OFF Toggle Switch to the "ON" position.

WARNING - To stop the unit in an emergency, turn motor off. Then relieve the fluid pressure in the pump and hose as instructed in the "Pressure Relief" Procedure on Page 6.

- Turn Pressure Control Knob CW to prime pump.
- After the pump is primed, turn Prime/PR Valve to the PRESSURE, "Closed" position.
- Turn Pressure Control Knob to the desired spray pressure.
- Disengage the gun safety latch and you are ready to spray.

WARNING - If you spray into the paint bucket, always use the lowest spray pressure and maintain firm metal to metal contact between gun and container. See Page 2 , Fig. 5.

STARTING UP continued

4. Adjusting the Pressure

- a. Turn the Pressure Control Knob CW to increase pressure and CCW to decrease pressure.
- b. Always use the lowest pressure necessary to completely atomize the material being sprayed.

CAUTION - Operating the sprayer at higher pressure than needed, wastes material, causes early tip wear and shortens sprayer life.

- c. If more coverage is needed use a larger tip rather than increasing the pressure.
- d. Check the spray pattern. The tip size and angle determines the pattern width and flow rate.

5. Cleaning a Clogged Tip.

WARNING - Follow the "Pressure Relief Procedure" on page 6 .

To reduce the risk of injection, never hold your hand, body, fingers or hand in a rag in front of the spray tip when cleaning or checking for a cleared tip. Always point the gun toward the ground or into a waste container when checking to see if the tip is cleared or when using a self-cleaning tip.

There is an easy way to keep the outside of the tip clean from material build up:

Every time you stop spraying, for even a minute, lock the gun and submerge it into a small bucket of thinner suitable for the material sprayed. Thinner will dissolve the buildup of paint on the outside of tip, tip guard and gun much more effectively if the paint doesn't have time to dry out completely.

WARNING - Clogged standard (flat) tip - clean only after the tip is removed from the gun and pressure has been relieved.

FOLLOW THE PRESSURE RELIEF PROCEDURE WARNING ON PAGE 6.

6. When Shutting off the Sprayer

- a. Whenever you stop spraying, even for a short break, follow the "Pressure Relief Procedure Warning" on page 6.
- b. Clean the tip & gun as recommended on page 13.
- c. Flush the sprayer at the end of each work day, if the material you are spraying is water-based, or if it could harden in the sprayer overnight. See "Flushing" pages 1 and 2. Use a compatible solvent to flush, then fill the pump and hoses with an oil based solvent such as mineral spirits.
- d. For long term shutdown or storage, refer to page 1.

WARNING - Be sure to relieve pressure in the pump after filling with mineral spirits.

WARNINGS

DO NOT USE halogenated solvents in this system. The prime valve and most airless guns have aluminum parts and may explode. Cleaning agents, coatings, paints or adhesives may contain halogenated hydrocarbon solvents. DON'T TAKE CHANCES! Consult your material suppliers to be sure. Some of the most common of these solvents are: Carbontetrachloride, Chlorobenzene, Dichloroethane, Dichloroethyl Ether, Ethylbromide, Ethylchloride, Tetrachloroethane. Alternate valves and guns are available if you need to use these solvents.

Note: United States Government safety standards have been adopted under the Occupational Safety & Health Act. These standards, particularly the General Standards, Part 1910 & Construction Standards, Part 1926 should be consulted.

WARNINGS CONTINUED ON NEXT PAGE.....

WARNINGS continued

HIGH PRESSURE SPRAY CAN CAUSE EXTREMELY SERIOUS INJURY. Handle as you would a loaded firearm. Follow PRESSURE RELIEF PROCEDURE on page 6. Observe all warnings.

MEDICAL ALERT - Airless Spray Wounds

If any fluid appears to penetrate your skin, get **EMERGENCY MEDICAL CARE AT ONCE. DO NOT TREAT AS A SIMPLE CUT.**
Tell the doctor exactly what fluid was injected.

NOTE TO PHYSICIAN: Injection in the skin is a traumatic injury. **It is important to treat the injury surgically as soon as possible. DO NOT DELAY treatment to research toxicity.** Toxicity is a concern with some exotic coatings injected directly into the blood stream. Consultation with a plastic surgeon or reconstructive hand surgeon may be advisable.

INJECTION HAZARD

Fluids under high pressure from spray or leaks can penetrate the skin and cause extremely serious injury, including the need for amputation. **NEVER** point the spray gun at anyone or any part of the body. **NEVER** put hand or fingers over the spray tip. Do not use rag or other materials over your fingers. Paint will penetrate through these materials and into the hand. **NEVER** try to stop or deflect leaks with your hand or body. **ALWAYS** have gun tip guard in place when spraying. **ALWAYS** lock gun trigger when you stop spraying. **ALWAYS** remove tip from the gun to clean it. **NEVER** try to "blow back" paint, this is not an air spray sprayer. **ALWAYS** follow the **PRESSURE RELIEF PROCEDURE**, as shown on page 6, before cleaning or removing the spray tip or servicing any system equipment. Be sure equipment safety devices are operating properly before each use. Tighten all fluid connections before each use.

ALWAYS INSPECT SPRAYING AREA

Keep spraying area free from obstructions. Make sure area has good ventilation to safely remove vapors and mists. **NEVER** keep flammable material in spraying area. **NEVER** spray in vicinity of open flame or other sources of ignition. Spraying area must be at least 20 ft. away from spray unit.

SPRAY GUN SAFETY

ALWAYS set safety lock on the gun in "LOCKED" position when not in use and before servicing or cleaning. **DO NOT** remove or modify any part of gun. **ALWAYS REMOVE SPRAY TIP** when cleaning. Flush unit with **LOWEST POSSIBLE PRESSURE**. **CHECK** operation of all gun safety devices before each use. Be very careful when removing the spray tip or hose from gun. A plugged line contains fluid under pressure. If the tip or line is plugged, follow the **PRESSURE RELIEF PROCEDURE** as outlined on page 6.

MEDICAL TREATMENT

If any fluid appears to penetrate your skin, get **EMERGENCY CARE AT ONCE. DO NOT TREAT AS A SIMPLE CUT.**

- * Go to an emergency room immediately.
- * Tell the doctor you suspect an injection injury.
- * Tell him what kind of material you were spraying with and have him **read NOTE TO PHYSICIAN above.**

TIP GUARD

ALWAYS have the tip guard in place on the spray gun while spraying. The tip guard alerts you to the injection hazard and helps prevent accidentally placing your fingers or any part of your body close to the spray tip.

SPRAY TIP SAFETY

Use extreme caution when cleaning or changing spray tips. If the spray tip clogs while spraying, engage the gun safety latch immediately. **ALWAYS** follow the **PRESSURE RELIEF PROCEDURE** and then remove the spray tip to clean it. **NEVER** wipe off build up around the spray tip. **ALWAYS** remove tip & tip guard to clean **AFTER** pump is turned off and the pressure is relieved by following the **PRESSURE RELIEF PROCEDURE.**

GENERAL PRECAUTIONS

NEVER alter equipment in any manner. **NEVER** smoke while in spraying area. **NEVER** spray highly flammable materials. **NEVER** use around children. **NEVER** allow another person to use sprayer unless he is thoroughly instructed on its' safe use and given this operators manual to read. **ALWAYS** wear a spray mask, gloves and protective eye wear while spraying. **ALWAYS** ensure fire extinguishing equipment is readily available and properly maintained. **NEVER LEAVE SPRAYER UNATTENDED WITH PRESSURE IN THE SYSTEM. FOLLOW PRESSURE RELIEF PROCEDURES ON PAGE 6.**

TOXIC FLUID HAZARD

Hazardous fluid or toxic fumes can cause serious injury or death if splashed in eyes or on skin, inhaled or swallowed. Know the hazards of the fluid you are using. Store & dispose of hazardous fluids according to manufacturer, local, state & national guidelines. **ALWAYS** wear protective eyewear, gloves, clothing and respirator as recommended by fluid manufacturer.

WARNINGS continued

PRESSURE RELIEF PROCEDURE

To avoid possible serious body injury, always follow this procedure whenever the sprayer is shut off, when checking it, when installing, changing or cleaning tips and whenever you stop spraying or when you are instructed to relieve the pressure.

1. Engage gun Safety Latch.

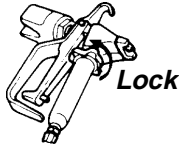

2. Turn motor off and unplug from electrical outlet.

3. Disengage gun safety latch and trigger gun to relieve residual fluid pressure. Hold metal part of the gun in contact with grounded metal pail.



4. Turn Prime/Pressure Relief Valve to the open (Priming) position to relieve residual fluid pressure. There will be a wider gap between valve handle and cam body when in open position.

Note: When in closed position there is only a very slight gap.

Note: The valve handle can move both CCW and CW and can face different directions.

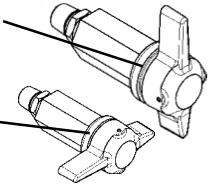

5. Re-engage gun safety latch and close Prime/Pressure Relief Valve.

If the **SPRAY TIP OR HOSE IS CLOGGED**, follow Step 1 through 5 above. Expect paint splashing into the bucket while relieving pressure during Step 4. If you suspect that pressure hasn't been relieved due to damaged prime/pressure relief valve or other reason, engage gun safety latch and take your unit to an authorized Airlessco Service Center.

HOSES

Tighten all fluid connections securely before each use. High pressure fluid can dislodge a loose coupling or allow high pressure spray to be emitted from the coupling and result in an injection injury or serious bodily injury.

Use only hose having a spring guard. The spring guard helps protect the hose from kinks or other damage which could result in hose rupture and cause an injection injury.

NEVER use a damaged hose, which can result in hose failure or rupture and cause an injection injury or other serious bodily injury or property damage. Before each use, check entire hose for cuts, leaks, abrasion or bulging of cover, or damage or movement of couplings. If any of these conditions exist, replace the hose immediately. Never use tape or any device to try to mend the hose as it cannot contain the high pressure fluid. NEVER ATTEMPT TO RECOUPLE THE HOSE. High pressure hose is not recoupleable.

GROUNDING

Ground the sprayer & other components in the system to reduce the risk of static sparking, fire or explosion which can result in serious bodily injury and property damage. For detailed instructions on how to ground, check your local electrical code. ALWAYS ensure switch is in OFF position before plugging unit in.

Always ground all of these components.

1. Sprayer: plug the power supply cord, or extension cord, each equipped with an undamaged three-prong plug, into a properly grounded outlet. DO NOT USE AN ADAPTER.

Use only a 3 wire extension cord that has a 3 blade grounding plug, and a 3 slot receptacle that will accept the plug on the product. Make sure your extension cord is in good condition. When using an extension cord, be sure to use one heavy enough to carry the current your product will draw. (Note: The table on the top of the next page shows the correct size to use depending on cord length and name plate ampere rating. If in doubt, use the next heavier gauge. The smaller the gauge number, the heavier the cord.)

2. Air Hoses; use only grounded hoses.
3. Fluid hose: use only grounded hoses.
4. Spray gun or dispensing valve; grounding is obtained through connection to a properly grounded fluid hose and pump.
5. Object being sprayed; according to your local code.
6. All solvent pails used when flushing.

Once each week, check electrical resistance of hose (when using multiple hose assemblies, check overall resistance.) Overall (end to end) resistance of unpressurized hose must not exceed 29 megohms (max.) for any coupled length or combination of hose lengths. If hose exceeds these limits, replace it immediately.

Never exceed 500 ft. (150 m) overall combined hose length to assure electrical continuity.

WARNINGS continued

UL RECOMMENDATION FOR MINIMUM GAUGE EXTENSION CORD

AMPERAGE RATING RANGE	VOLTAGE	LENGTH OF CORD IN FEET								
		25	50	100	150	200	250	300	400	500
5 - 6	120	18	16	12	12	10	10	8	8	6
6 - 8	120	18	16	12	10	10	8	6	6	6
8 - 10	120	18	14	12	10	8	8	6	6	4
10 - 12	120	16	14	10	8	8	6	6	4	4

Always follow recommended pressure and operating instructions.

KEEP CLEAR OF MOVING PARTS

Keep clear of moving parts when starting or operating the sprayer. Do not put your fingers into any openings to avoid amputation by moving parts or burns on hot parts. Precaution is the best insurance against an accident. When starting the motor, maintain a safe distance from moving parts of the equipment. Before adjusting or servicing any mechanical part of the sprayer, follow the PRESSURE RELIEF PROCEDURE on page 6.

AVOID COMPONENT RUPTURE

This sprayer operates at 3000 psi (205 bar). Always be sure that all components and accessories have a maximum working pressure of at least 3000 psi to avoid rupture which can result in serious bodily injury including injection and property damage.

NEVER leave a pressurized sprayer unattended to avoid accidental operation of it, which could result in serious bodily injury.

ALWAYS follow the PRESSURE RELIEF PROCEDURE whenever you stop spraying and before adjusting, removing or repairing any part of the sprayer.

NEVER alter or modify any part of the equipment to avoid possible component rupture which could result in serious bodily injury and property damage.

NEVER use weak or damaged or non-conductive paint hose. Do not allow kinking or crushing of hoses or allow it to vibrate against rough or sharp or hot surfaces. Before each use, check hoses for damage and wear and ensure all fluid connections are secure.

REPLACE any damaged hose. NEVER use tape or any device to mend the hose.

NEVER attempt to stop any leakage in the line or fittings with your hand or any part of the body. Turn off the unit and release pressure by following PRESSURE RELIEF PROCEDURE.

WHEN SPRAYING & CLEANING WITH FLAMMABLE PAINTS AND THINNERS

1. When spraying with flammable liquids, the unit must be located a minimum of 25 feet away from the spraying area in a well ventilated area. Ventilation must be sufficient enough to prevent the accumulation of vapors.
2. To eliminate electrostatic discharge, ground the spray unit, paint bucket & spraying object. See GROUNDING on pg. 6. Use only high pressure airless hoses approved for 3000 psi which is conductive.
3. Remove spray tip before cleaning gun and hose. Make contact of gun with bucket and spray without the tip in a well ventilated area, into the grounded steel bucket.
4. Never use high pressure in the cleaning process. **USE MINIMUM PRESSURE.**
5. Do not smoke in spraying/cleaning area.

ALWAYS use approved high pressure fittings and replacement parts.

ALWAYS ensure fire extinguishing equipment is readily available and properly maintained.

PREVENT STATIC SPARKING FIRE/EXPLOSIONS

ALWAYS be sure all equipment & objects being sprayed are properly grounded. Always ground sprayer, paint bucket and object being sprayed. See grounding on page 6 for grounding information.

Vapors created when spraying can be ignited by sparks. To reduce the risk of fire, always locate the sprayer at least 20 feet (6 m.) away from spray area. Do not plug in or unplug any electrical cords in the spray area, which can create sparks, when there is any chance of igniting vapors still in the air. Follow the coating & solvent manufacturers safety warnings and precautions.

Use only conductive fluid hoses for airless applications. Be sure gun is grounded through hose connections. check ground continuity in hose & equipment. Overall (end to end) resistance of unpressurized hose must not exceed 29 megohms for any coupled length or combination of hose length. Use only high pressure airless hoses with static wire approved for 3000 psi.

FLUSHING

Reduce the risk of injection injury, static sparking or splashing by following the specific cleaning process. ALWAYS follow the PRESSURE RELIEF PROCEDURE on page 6.

ALWAYS remove the spray tip before flushing. Hold a metal part of the gun firmly to the side of a metal pail and use the lowest possible fluid pressure during flushing.

NEVER use cleaning solvents with flash points below 140 degrees F. Some of these are: acetone, benzene, ether, gasoline, naphtha. Consult your supplier to be sure. NEVER SMOKE in the spraying/cleaning area.

AIRLESSCO 007 SPRAY GUN

SPRAY GUN

Attach spray gun to whip hose and tighten fittings securely. Set the gun safety latch. (Also may be called gun safety lock) * Refer to Fig. A.

* The gun safety latch should always be set when the gun is not being triggered.

Read all warnings and safety precautions supplied with the spray gun and in product manual.

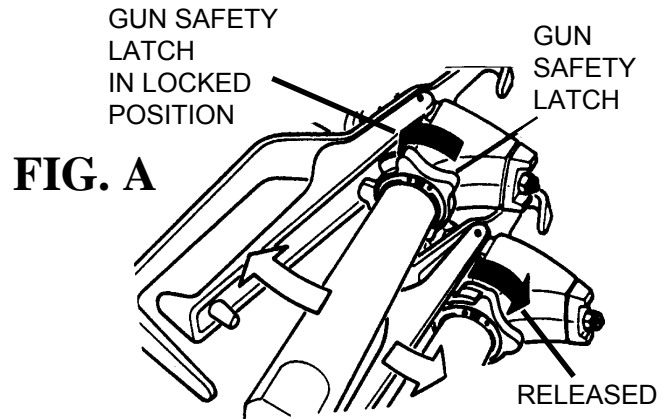

MAJOR COMPONENTS OF SPRAY GUN AND REVERSIBLE SPRAY TIP

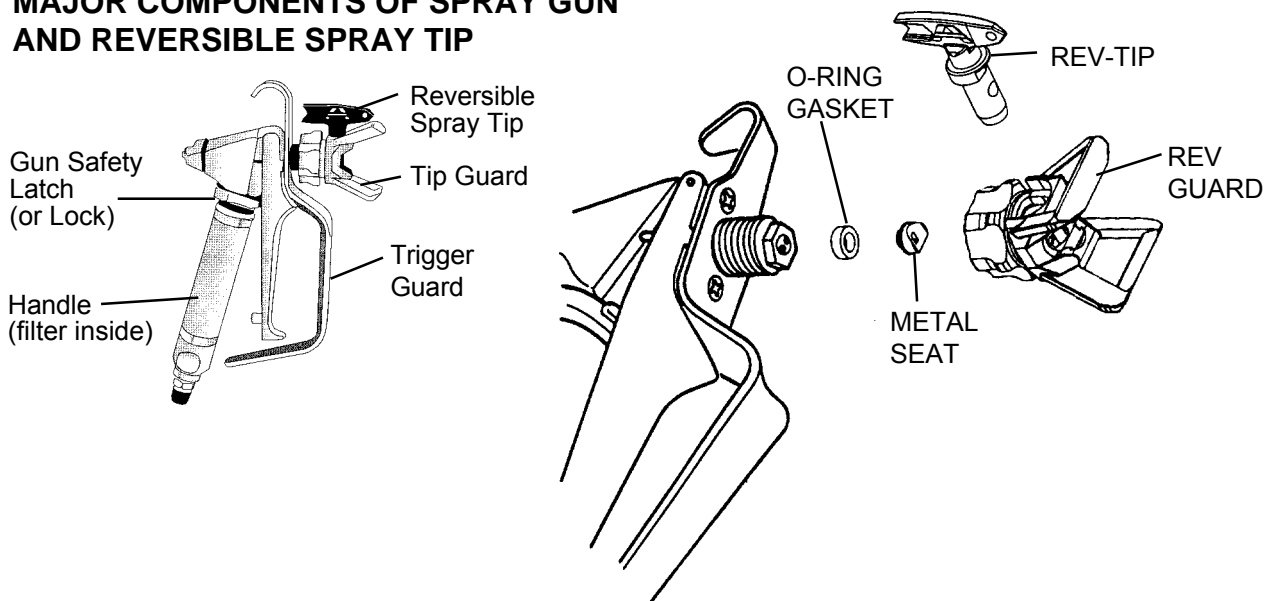

SPRAY TIP ASSEMBLY

1. Be sure the pressure relief procedure is followed before assembling tip and housing to the gun.
2. Insert Rev-Tip cylinder into REV-GUARD (guard housing assembly).
3. Guide the metal seat into REV-GUARD (guard housing assembly) through the retaining nut and turn until it seats against the cylinder.
4. Insert the O ring gasket onto the metal seat so that it fits into the grooves.
5. Finger tighten the REV-GUARD retaining nut onto the gun.
6. Turn guard in the desired position.
7. Completely tighten the retaining nut.

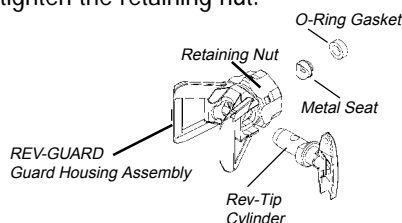

TO REMOVE CLOGS FROM SPRAY TIP

1. Turn Rev-Tip handle 180 degrees.
2. Disengage gun safety latch and trigger gun into pail.
3. Engage gun safety latch and return handle to spraying position.

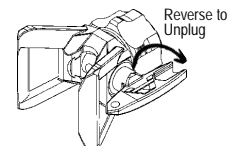

Spray Position Shown

SPRAY TIP SELECTION

Spray tip selection is based on paint viscosity, paint type, and job needs. For light viscosities (thin paints), use a smaller tip; for heavier viscosities (thicker paints), use a larger tip size.

Spray tip size is based on how many gallons of paint per minute can be sprayed through the tip. Do not use a tip larger than the maximum pump flow rate or capacity the sprayer can accommodate. Pump flow rate is measured in gallons per minute (GPM).

TIP SELECTION CHART

FULL RANGE OF TIP SIZES

REV -TIPS (P.N. 560-XXX)
FLAT TIPS (P.N. 570-XXX)

Tip Identification: All tips have a 6 digit part number. The first 3 digits identifies it as a Rev-Tip (560) or a Flat Tip (570). The 4th digit is the fan width - the number is half the fan width, ie. 5 means a 10" fan when it is held 12" from the surface. The 5th and 6th digit is for the orifice size and is measured in thousands of an inch, ie: 17 = 0.017 inch- the higher the number, the larger the tip.

For sizes not shown, call factory for availability.

Fan Width		Orifice Size (Inch)										
in.	(mm)	.011	.013	.015	.017	.019	.021	.023	.025	.027	.031	.035
4-6	(102-152)	211	213	215	217	219						
6-8	(152-203)	311	313	315	317	319	321	323	325	327		
8-10	(203-254)	411	413	415	417	419	421	423	425	427	431	
10-12	(254-305)	511	513	515	517	519	521	523	525	527	531	535
12-14	(305-356)		613	615	617	619	621	623	625	627	631	635
14-16	(356-406)			715	717		721					
16-18	(406-457)			815		819	821				831	
Water Flow Rate (gpm)		.12	.18	.24	.31	.38	.47	.57	.67	.77	1.03	1.31
Tip Flow Rate -water (lpm) (Water @ 2000 psi, 138 bar)		.49	.69	.91	1.17	1.47	1.79	2.15	2.54	2.96	3.90	4.98
Paint Flow Rate (gpm)		.10	.15	.21	.27	.33	.40	.49	.58	.66	.88	1.12
Tip Flow Rate -water (lpm) (latex paint @ 2000 psi, 138 bar/1.36 spec.)		.38	.57	.79	1.02	1.25	1.51	1.85	2.20	2.50	3.33	4.24
Pump Minimum -pa (gpm)		.25	.25	.33	.40	.50	.60	.75	.88	1.0	1.25	
Output* Rate -water (lpm)		1.0	1.0	1.25	1.5	1.9	2.3	2.8	3.3	3.8	4.7	
*Pump will support tip worn to next larger size												
Gun Filter	C= Coarse - 60 mesh F= Fine - 100 mesh	F	F	F,C	C	C	C	C	REMOVE FILTER			
Wood Interior	Lacquer, Varnish Stain, Sealer Enamel	•	•	•								
Wood Exterior	Exterior Stain Vinyl, Acrylic, Latex			•	•	•	•					
Masonry	Vinyl, Oil Base Alkyd Latex, Acrylic Block Filler Elastomer			•	•	•	•	•	•	•	•	•
Ceiling	Hi Build, Mil White						•	•				
Structural Steel	Heavy Coatings						•	•	•	•	•	•

Consult your paint manufacturer for application recommendation.

PATTERN WIDTH

Thickness of the paint coat per stroke is determined by spray tip "fan width", rate of the spray gun movement, and distance to surface.

SPRAY TIP SELECTION

Two tips having the same tip size, but different pattern widths will deliver the same amount of paint over a different area (wider or narrower strip).

A spray tip with a narrow pattern width makes it easy to spray in tight places.

SPRAY TIP REPLACEMENT

During use, especially with latex paint, high pressure will cause the orifice to grow larger. This destroys the pattern. Replace tips before they become excessively worn. Worn tips waste paint, cause overspray, make cutting-in difficult, and decreases sprayer performance.

SPRAY TECHNIQUE

Good Spray Gun Technique is at the core of any spray paint operation. Operator skill and efficiency is as important as good equipment and good paint. Good spray technique is a skill that can be quickly learned by following these simple instructions.

If you are not familiar with spraying techniques, we recommend that you study this section of your manual and practice the proper technique on pieces of cardboard or a suitable surface.

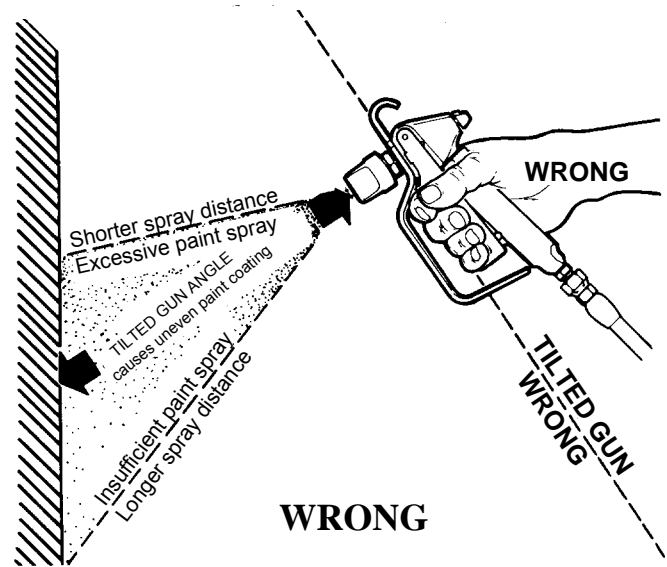
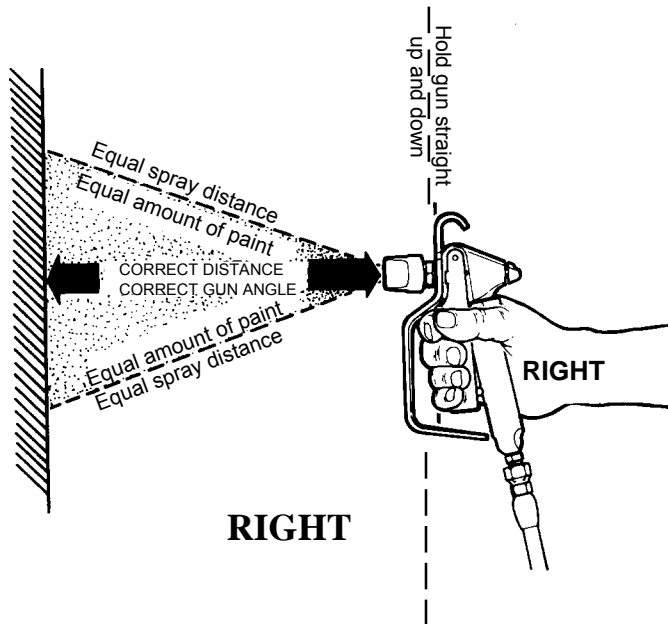

Hold the spray gun 12 - 15 inches away from the work surface and keep it perpendicular (straight) to the surface. Move the spray gun parallel to the work and at a right angle to the surface.

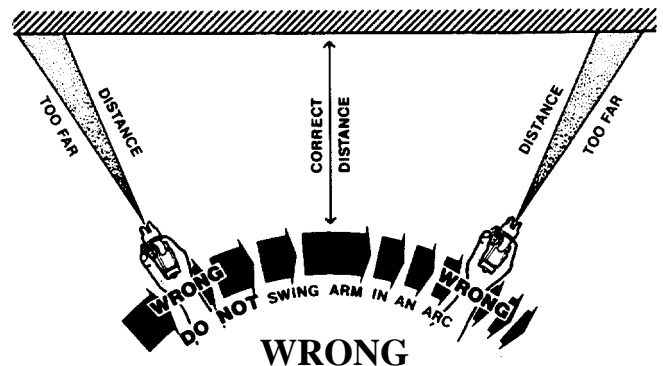
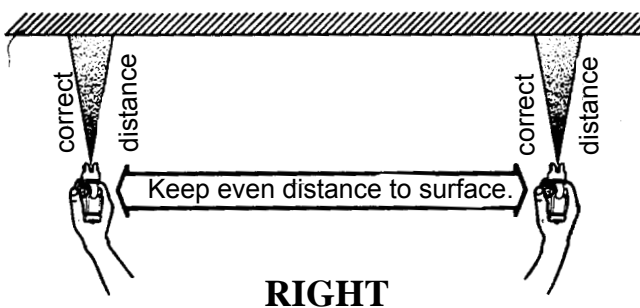

Move the gun at a steady rate in order to apply a good coverage. The wet coat should be just under the thickness at which a run or sag will occur. Slow gun movement or gun held too close will result in an overly wet or thick wet or thick coat coverage that is likely to run or sag.

The closer the spray gun is held to the work, the thicker the paint is deposited and the faster the gun must be moved to prevent sags and runs. Holding the gun too far from the work will cause excessive fog, overspray, and a thin and grainy coat.

Do not wave the spray gun. This waving is called arching. Instead, hold the spray gun at a 12 to 15 inch distance perpendicular from the work.

SPRAY TECHNIQUE

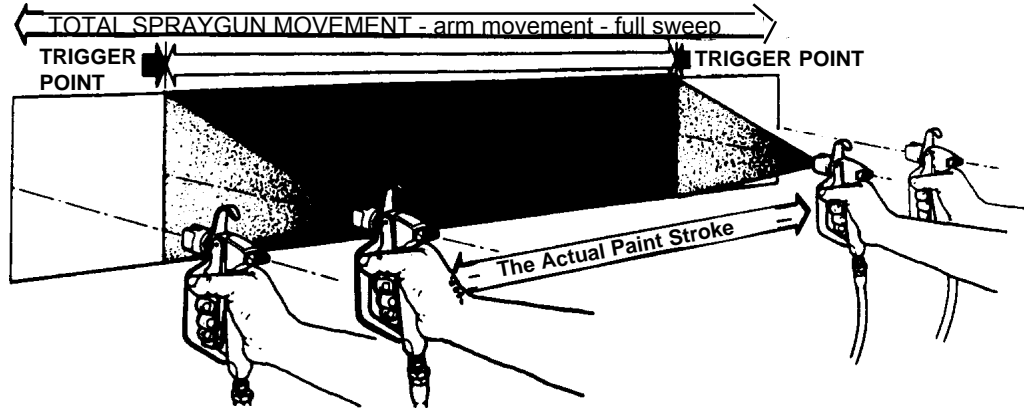

It is important to "trigger" the gun after gun movement (arm movement) has started and release trigger (shut gun off) before gun movement ends. Gun movement is always longer than actual paint (spray) stroke. In that manner, even blending and uniform paint coat thickness is achieved over the entire surface. When the gun is in motion as the trigger is pulled, it deposits an even amount of paint.

Spray with uniform strokes from left to right and from right to left, holding stroke speed, distance, lapping, and triggering as uniform as possible.

Overlap the previous pass by half the width of the spray pattern. Aim at the bottom of the previous pass.

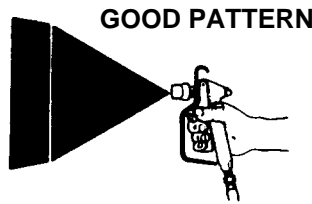
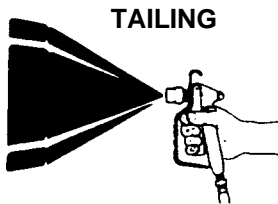
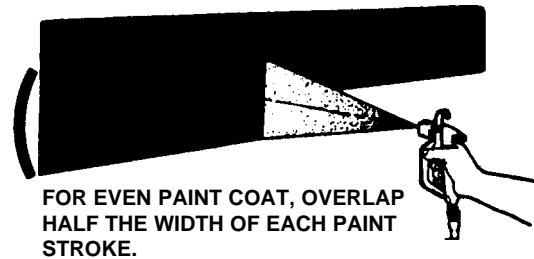

Adjust pressure control knob so that paint is completely atomized from the spray gun. Insufficient pressure will result in "tailing".

Too much pressure will result in excess fog and overspray, excessive tip wear, and increased sprayer wear and tear.

POOR PATTERN GOOD PATTERN

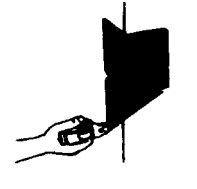
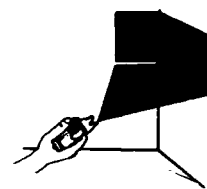
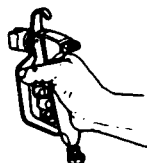

Always use the lowest pressure possible to obtain desirable results.

"Inside" and "outside" corners can be sprayed.

Test the spray pattern on a piece of cardboard or other surface.

Aim the spray gun toward the center of the corner. The spray pattern is divided in half, and the edges of the spray pattern on both walls are the same.

AIRLESSCO 007X & 007XL SPRAY GUNS

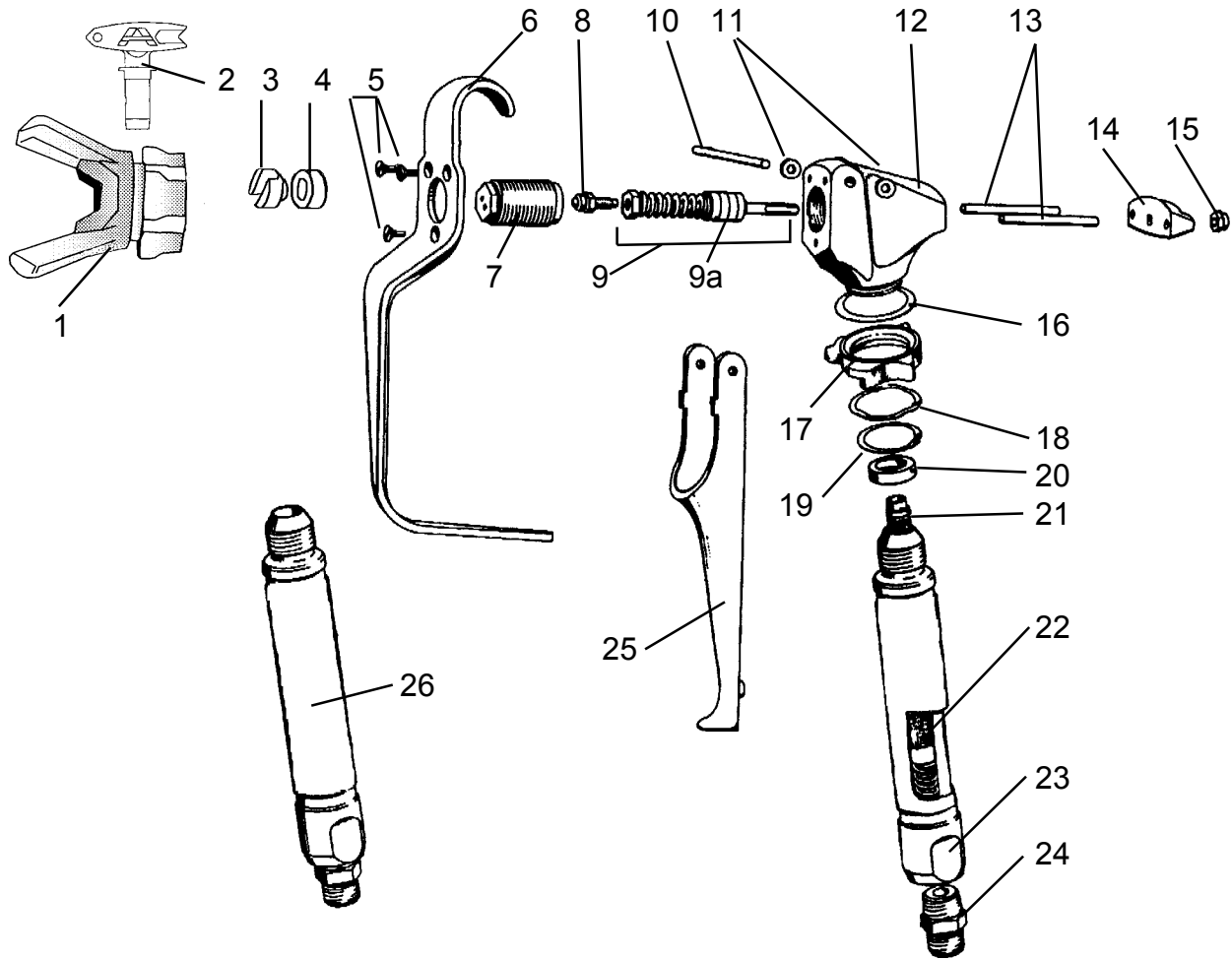

Item No.	Part No.	Description	Item No.	Part No.	Description
1	561-001	Rev-Guard	15	120-021	Nut
2	560-xxx	Rev-Tip	16	120-056	Washer
3	561-025	Rev-Tip Seal-metal	17	120-048	Safety Latch or Lock
4	561-026	Rev-Tip Seal-O-ring	18	120-055	Wave Washer
5	120-023	Screw (3)	19	120-049	Retaining Ring
6	120-005	Guard	20	120-082	Seal
7	120-035	Valve Seat Complete	21	120-090CX	Filter-Complete-Coarse
8	120-037	Valve Ball with Holder	21	120-090FX	Filter-Complete-Fine
9	120-011	Valve Spring Unit	22	120-088	Spring
9a	120-033	Seals PTFE (2)	23	120-087	Handle Complete 007X
10	120-022	Trigger Pin	24	115-019	Connector
11	120-046	Washer (2)	25	120-044	Trigger
12	120-002	Gun Head	26	120-085	Handle with Swivel 007XL
13	120-045	Retainer Pin (2)			
14	120-020	Retainer			

AIRLESSCO 007X & 007XL SPRAY GUN

Attach spray gun to hose and tighten fittings securely. Set the gun safety latch.(Also may be called gun safety lock) The gun safety latch should always be set when the gun is not being triggered.

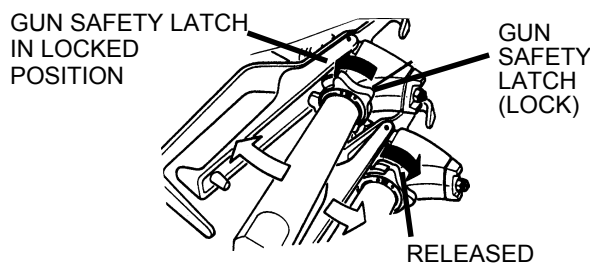

ADJUSTING SPRAY GUN

Hold gun with trigger locked (25) and push trigger against the lock (17). Then adjust nut (15) so that the retainer (14) will move freely back and forth approximately 1/32" to allow valve spring unit (9) to seat the valve ball (8).

IMPORTANT: Readjust nut (15) periodically for wear of valve seat (7) and valve ball (8); otherwise, leakage will occur.

TO REPLACE THE VALVE BALL HOLDER (8)

KIT #2-007

3 Tip Washers 1 Valve Seat (7)
1 Valve Ball Holder (8) 2 Seals- PTFE (9a)

Dismantling:

1. Unscrew Rev-Guard and remove spray tip and seal.
2. Unscrew valve seat (7) with 1/2" socket wrench.

Caution

When removing and replacing valve seat (7), hold the trigger (25) in the open position so that the valve ball (8) is lifted off the valve seat. Failure to lift the ball off the seat will result in a scratched leaky valve.

3. Unscrew valve ball (8) together with the brass part of the assembly (9). Do not pull on the parts or the packing may get damaged.
4. Unscrew the valve ball (8) from the brass part of the assembly (9).

Reassembling is done in reverse sequence. Screw the new valve ball with holder (8) into the brass part (9).

Caution

Tighten valve ball and brass part on threaded end of the shaft by hand until you feel a positive stop. Do not tighten with a wrench since this could result in breaking the shaft.

Note it is recommended that you change the valve seat (7) and valve ball (8) at the same time.

REPLACING THE VALVE SPRING UNIT (9)

KIT#3-007

3 Tip Washers 1 Valve Seat (7)
1 Valve Ball Holder (8) 1 Valve Spring Unit (9)

1. Repeat dismantling procedure as outlined above under Steps 1 through 3.
2. Unscrew nut (15), remove retainer (14) with retainer pins (13) and push shaft of the valve spring unit (9) out of the gun head (12).
3. Clean gun head (12) bore with solvent and small brush. Do not use any sharp objects to scrape away dried paint, as they would cause leakage around the seal.

Reassembling is done in reverse sequence. **IMPORTANT: When reassembling, install valve spring unit (9) with spring loose.**

Push firmly into gun head by hand. Install retainer pins (13), retainer (14) and nut (15) loosely onto valve spring unit (9). By hand turn front of valve spring unit clockwise, tightening the valve spring unit until you feel a positive stop. At that point, continue tightening the valve spring another 1/8 turn expanding the PTFE seals against body of gun.

Caution

Do not tighten beyond 1/8 turn as this can result in breaking the valve spring unit shaft. Continue reassembly and adjustment as described above.

CLEANING 007 SPRAY GUN

Immediately after the work is finished, flush the gun out with a solvent. Brush pins (13) with solvent and oil them lightly so they will not collect dried paint.

TO REMOVE CLOGS- REVERSIBLE TIP

1. Turn Rev-Tip handle 180 degrees.
2. Disengage gun safety latch & trigger gun into pail.
3. Engage gun safety latch and return handle to spraying position.

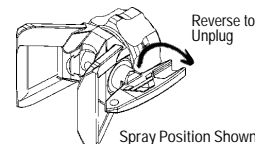

CLOGGED FLAT TIP -Should the spray tip become clogged, relieve pressure from hoses by following the "Pressure Relief Procedure" in Machine Manual, secure the gun with safety lock (17), take off Guard, take out the tip, soak in appropriate solvent & clean with a brush. (Do not use a needle or sharp pointed instrument to clean the tip. The tungsten carbide is brittle and can chip.)

CLEANING FILTER

To clean the filter, use a brush dipped in as appropriate solvent. Change or clean filters at least once a day. Some types of latex may require a filter change after four hours of operation.

AIRLESS SPRAY GUN TROUBLESHOOTING

<u>DEFECTS</u>	<u>CAUSE</u>	<u>CORRECTION</u>
Coarse spray	Low pressure	Increase the pressure.
Excessive fogging (overspray)	High pressure Material too thin	Reduce the pressure to satisfactory pattern distribution. Use less thinner.
Pattern too wide	Spray angle too large	Use smaller spray angle tip.
Pattern too narrow	Spray angle too small	Use larger spray angle tip. (If coverage is OK, try tip in same nozzle group)
Too much material	Nozzle too small Material too thin Pressure too high	Use next smaller nozzle. Reduce pressure.
Too little material	Nozzle too small Material too thick	Use next larger nozzle.
Thin distribution in center of pattern "horns".	Worn tip Wrong tip	Change for new tip. Use nozzle with a narrow spray angle.
Thick skin on work	Material too viscous Application too heavy	Thin cautiously. Reduce pressure and/or use tip in next larger nozzle group.
Coating fails to close & smooth over	Material too viscous	Thin cautiously.
Spray pattern irregular, deflected	Orifice clogged. Tip damaged	Clean carefully. Replace with new tip.
Craters or pock marks, bubbles on work	Solvent balance	Use 1 to 3% "short" solvents remainder "long" solvents. (This is most likely to happen with material of low viscosity, lacquers etc.)
Clogged screens	Extraneous material in paint. Coarse pigments Poorly milled pigments (paint pigments glocculate cover screen. Incompatible paint mixture & thinners.	Clean screen Use coarse screen if orifice size allows. Use coarser screen, larger orifice tips. Obtain ball milled paint. If thinner has been added, test to see if a drop placed on top of paint mixes or flattens out on the surface. If not, try different thinner in fresh batch of paint.

TEST THE PATTERN

Good, full



Spotty Pattern
Increase Pressure.



REGULAR MAINTENANCE

1. Keep the displacement pump packing nut/wet cup 1/3 full of TSO (Throat Seal Oil) at all times. The TSO helps protect the packings and rod.
2. Inspect the packing nut daily. Your pump has a patented Triple Life Packing System. Packing life will be extended a minimum of three times if the following "**Packing Tightening**" procedure is followed:

Inspect the packing nut daily. If seepage of paint into the packing nut and/or movement of the piston upward is found (while not spraying), the packing nut should be tightened enough to stop leakage only, but not any tighter. Overtightening will damage the packings and reduce the packing life.

ELECTRIC MOTOR MAINTENANCE

1. **LUBRICATION** - This motor is supplied with prelubricated ball bearings, lubricated for the life of the bearing.
2. **MOTOR BRUSHES** need periodic inspection and replacement as wear indicates. Brush wear is greatly influenced by individual application. It is recommended that brush wear be checked at early intervals of operation in order to determine future required inspections. Standard Leeson brushes for this motor have an initial length of 3/4". When the brushes are worn to a length of 3/8", they should be replaced.
3. **TO CHANGE BRUSHES**, follow the procedures below:
 - a) Unplug the machine.
 - b) Open the two covers at the rear of the motor.
 - c) Loosen the screw holding the brush terminal and remove the brush lead.
 - d) Push the brush retainer clip (PN 331-398) in and remove.
 - e) Remove the worn brushes (one on each side of motor).
 - f) Install new brushes in reverse order and replace covers.

NOTE: For longer life, new brushes (Part No. 331-131) need to have a run in period. After changing brushes, set up the machine for spraying. Use a bucket of water and Coro-Chek mixture, a 50' x 1/4" airless hose, airless gun with a .017 tip on unit, turn the Prime/PR Control Valve to the Prime position and turn the unit on. Turn the ON/OFF Pressure Control Knob to maximum pressure (fully CW position) and let the pump cycle at high speed and zero pressure for 20 minutes. This will allow the brushes to "run in" properly, giving a longer life.

TROUBLESHOOTING

PROBLEM	CAUSE	SOLUTION
There is spitting from the gun.	The fluid supply is low or empty.	Refill the supply container.
	Air entrapped in the fluid pump or hose.	Check for loose connections on the siphon assembly, tighten, then reprime pump.
Paint leaks into the wet cup.	The wet cup is loose.	Tighten just enough to stop leakage.
	The throat packings are worn or damaged.	Replace the packings. See page 24 & 25
	Piston Rod is Worn.	Replace Piston. See page 23
The motor operates, but the paint pump doesn't.	The pressure setting is too low.	Increase the pressure.
	The pump is seized by dried paint.	Service the pump. See page 23, 24, 25
The motor and displacement pump operates, but paint pressure is too low or none.	The pressure setting is too low.	Increase the pressure.
	The tip or gun filter is clogged.	Remove the tip and/or filter and clean them.
	Tip is worn.	Replace Tip.
	The fluid displacement pump filter is clogged.	Clean the filter.
	There is a large pressure drop in the fluid hose.	Use a larger diameter hose.
	The displacement pump operates but the output is too low.	The lower or upper check valve is not seating.
	The packings are worn or damaged.	Replace the packings. See page 24, 25.
	The Prime/PR Valve is bypassing.	Replace the Prime/PR Valve.

TROUBLESHOOTING- Machine does not start.

<u>CAUSE</u>	<u>SOLUTION</u>
Control Settings	<p>STEP 1: Ensure that the ON-Off toggle switch is in the "ON" position and that the Pressure Control Knob is fully CW (maximum pressure). Also check that the unit is plugged in.</p> <p>STEP 2: Lower the pressure control assembly and check if the green power light on the board is lit. If the light is "OFF", proceed to Step 3. If the light is "ON", go to Step 7.</p>
Power Source	<p>STEP 3: Use a multimeter to check for 110 volts VAC across the L1 and L2 terminals on the board. If there is no voltage at these leads, there is no power to the unit. Check power source (outlet, breakers, extension cord and power cord).</p>
Fuse	<p>STEP 4: If the machine has power and the green light is "OFF", test the fuse for continuity or replace with a new fuse.</p>
Thermal Overload	<p>STEP 5: If the fuse is okay, disconnect the two red motor leads (S1 & S2) and test for continuity between the two leads. Continuity shows that the motor's thermal coupler has not tripped. No continuity means that the thermal coupler has opened due to excessive motor heat. If the motor is still hot to touch, allow to cool and retest. If the motor is cool and there is no continuity on the red leads, contact your local Leeson repair facility to repair/ replace the thermal coupler.</p>
Pressure Control Assembly (Board)	<p>STEP 6: If all checks out fine in Steps 1 through 5 and the green light is still out, the pressure control assembly is defective and must be replaced.</p>
Sensor	<p>STEP 7: If the green light is "ON", the power source, fuse and thermal coupler are okay. Plug another sensor into the board. If the unit starts, the sensor was faulty and must be replaced. When a replacement sensor is not available, use a multimeter to test the resistance between the BLACK and RED wires on the sensor lead. The resistance should be approximately 1.5-3.5 kohms. A faulty sensor usually reads zero resistance (open).</p>
Pressure Control Knob (Potentiometer)	<p>STEP 8: With the machine still "OFF", remove the potentiometer lead from the board and read the resistance between the red and black wires. This must be 8 - 12 kohms. If outside this range, replace the potentiometer. NOTE: A bad POT will usually show no resistance (open).</p>
Motor	<p>STEP 10: Remove the two black motor leads (A1 & A2) and test for continuity between them. Continuity is an indication that the motor is sound. The lack of continuity, points to a problem in the motor. If there is no continuity on these two leads, check the motor brushes. Ensure that the brushes are evenly worn and make solid contact with motor commutator. Replace the brushes if they are less than 3/8" long. If the brushes are okay, replace the motor.</p>
Pressure Calibration	<p>STEP 11: Calibrate the pressure control assembly in accordance with the instructions on page 18.</p>
Pressure Control Assembly (Board)	<p>STEP 12: If the unit fails to calibrate and all components in Steps 1-10 test okay, the pressure control assembly needs to be replaced.</p>

PRESSURE CONTROL ASSEMBLY (PCA)

Note: Anytime a sensor, pressure control assembly (board) or both are replaced, the following three calibrations must be performed.

1. ZERO CALIBRATION

1. Place prime/pressure relief valve in the prime (open) position.
2. Set the pressure control knob to the minimum setting (CCW).
3. Remove the screws (Fig. 17, Item 24) and lower the pressure control assembly. Ensure PCA is grounded.
4. Ensure the jumper (Fig. 10, Item 9) is on the "P-ZR" terminal. Note: This jumper comes with a new pressure control assembly (board) and is installed on the "P-ZR" terminals. If you are "Zero Calibrating" a pressure control assembly presently in the unit, remove Jumper from Single Terminal P-ZR and place on both terminals P-ZR. When Zero Calibration is complete replace jumper on a single terminal of P-ZR.
5. Turn machine "ON" and ensure it is not cycling.
6. If the yellow light on the electrical board is ON, use an insulated screwdriver to turn the "ZERO" trimpot counter-clockwise until the light goes out. Then turn it clockwise until the light just comes back on.
7. If the yellow light is OFF, turn the "Zero" trimpot clockwise, just until the light comes on and stop.
NOTE: If the yellow light remains constantly "ON", or "OFF" during this calibration, the sensor is defective and should be replaced.
8. When calibration is complete, move jumper from both "PZ-R" terminals to single terminal on P-ZR.

2. PRESSURE CALIBRATION

1. Attach a 50', 1/4" airless hose, airless gun with 0.017 tip and a 5000 psi glycerine filled pressure gauge to the pump.
2. Place the suction tube into a bucket of Coro-chek and water.
3. Turn Prime/pressure relief valve to the prime (open) position.
4. Complete the ZERO calibration, as per "ZERO CALIBRATION".
5. Turn pressure control knob clockwise until machine starts to prime.
6. Place the prime/pressure relief valve in the pressure (closed) position.
7. While watching pressure gauge, slowly adjust the Pressure Trimpot (clockwise to increase and counter clockwise to decrease) until the maximum static pressure is 3000 psi, with the pressure control knob fully clockwise. Trigger the gun several times to ensure pressure returns to 3000 psi .

3. LOW PRESSURE VOLTAGE TRIMPOT CALIBRATION

1. Attach a 50', 1/4" airless hose, airless gun with .017 tip and a 5000 psi glycerine filled pressure gauge to the pump.
2. Place the suction tube into a bucket of antifreeze (or Coro-chek) and water.
3. Turn pump ON and turn up pressure control until the machine starts to prime.
4. Place the prime/pressure relief valve in the pressure (closed) position.
5. Pressurize pump to 600 psi.
6. Trigger the gun several times noting the deadband (the amount of pressure drop before the pump rebuilds to set pressure).
7. If deadband is greater than 100 psi, adjust the low pressure voltage trimpot so that the deadband is less than 100 psi and the pressure increase after the gun trigger is released is less than 200 psi. These pressures are guidelines and may vary slightly from pump to pump.

ELECTRICAL SYSTEM

FIGURE 10

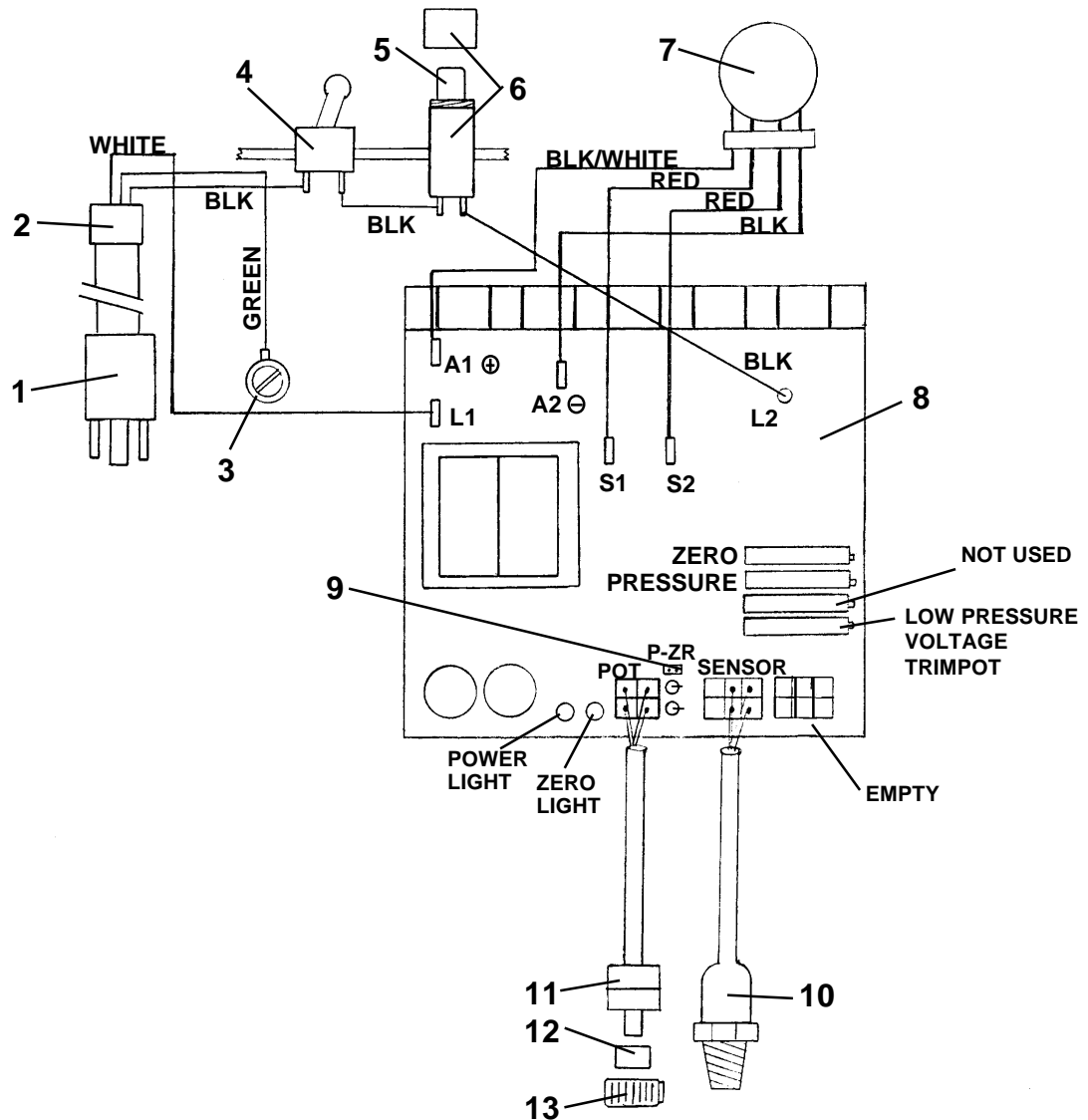

FIGURE 10 PARTS LIST

ITEM NO.	PART NO.	DESCRIPTION
1	331-168C	Electrical Power Cord
2	331-185	Strain Relief
3	331-138	Screw
4	331-311	Toggle Switch
5	331-165	Fuse 12A Slow Blow (2400)
6	331-328	Fuse 20A Slow Blow (2500/2600)
7	331-312	Fuse Holder
7	331-070	1/2 HP DC Motor (2400)
8	331-068	3/4 HP DC Motor (2500/2600)
8	331-315	Pressure Control Ass'y
9	117-207	Jumper
10	331-294	Sensor
11	331-297	Potentiometer
12	331-184	Spacer
13	117-044	Knob

REPLACEMENT OF ELECTRICAL COMPONENTS

NOTE: Anytime the pressure control assembly, sensor or both are replaced, perform the three calibrations on page 18.

WARNING: Always unplug the electrical cord before servicing machine.

PRESSURE CONTROL ASSEMBLY (Electrical Control Board)

1. Unplug machine's power cord.
2. Remove four screws (Item 24, Fig. 17) from pressure control assembly.
3. Disconnect all leads from pressure control assembly. (Fig. 10).
4. Reassemble in reverse order.

SENSOR

1. Remove the screws (Fig. 17, Item 24) and lower the pressure control assembly.
2. Disconnect swivel (Item 17, Fig. 17) from sensor (Item 16, Fig. 17) by holding sensor with 7/8" wrench and loosening swivel with 11/16" wrench.
3. Disconnect sensor lead from the board. Carefully pull sensor lead out of the terminal box and remove sensor.
4. Reassemble in reverse order.

POTENTIOMETER (Pressure Control Knob)

1. Lower pressure control assembly as described above.
2. Disconnect potentiometer lead from pressure control assembly.
3. Use a 1/16" allen wrench, loosen set screw in the potentiometer knob (Item 13, Fig. 10) and remove knob and spacer. (Item 12, Fig. 10).
4. Using a 1/2" wrench or deep socket, remove the nut from the potentiometer shaft assembly.
5. Pull entire potentiometer assembly out of terminal box.
6. Replace in reverse order.

ON-OFF TOGGLE SWITCH

1. Lower the pressure control assembly as described above.
2. Disconnect the two wires on the switch.
3. Use a 9/16" wrench to loosen the nut on the toggle switch shaft.
4. Reassemble in reverse order.

FUSE HOLDER

1. Lower pressure control assembly as described above.
2. Disconnect the two wires on the switch.
3. Use a 9/16" wrench to loosen the nut on the toggle switch shaft.
4. Reassemble in reverse order.

SERVICING THE FLUID PUMP

NOTE: Check everything in the Troubleshooting Chart before disassembling the Fluid Pump.

SEE FIG 12, Page 22.

FLUID PUMP DISCONNECT

- a. Flush out the material you are spraying, if possible.
- b. Follow the "Pressure Relief Procedure" on page 6.
- c. Remove the suction tube assembly from the paint pump by unscrewing the suction nut. Disconnect sensor assembly by holding sensor with 7/8" wrench and unscrewing swivel connector with an 11/16" wrench.
- d. Move the piston rod to its lowest stroke position by rotating the motor fan or by cycling rod to lowest position.
- e. Unscrew the two screws (14) from cover assembly.
- f. Remove retaining ring (12) down off crosshead assembly (3). Push pin (10) out of crosshead allowing removal of fluid pump from unit.

FLUID PUMP REINSTALL:

- a. Loosen packing nut and extend piston rod to its upper position in paint pump. Slip sleeve and retaining ring over piston rod.
- b. Push piston rod up into crosshead assembly and align holes. Insert pin through crosshead assembly and piston. Insert retaining spring into groove on crosshead assembly.
- c. Secure paint pump to cover assembly by two screws, up through tube spacers and screw into cover assembly.
- d. Tighten screws evenly and alternating to 20 ft. lbs.

e. Reassemble the Lower Check Valve assembly by placing the Suction Seat Assembly, O-ring, ball and retainer in the suction nut and screw nut onto pump body.

f. Reconnect sensor assembly to fluid pump. Hold sensor with 7/8" wrench while tightening swivel connector.

g. Start the pump and operate slowly to check the Piston Rod for binding. Adjust screws holding pump assembly to cover assembly if necessary to eliminate binding.

h. Tighten the packing nut until resistance is felt against the belleville springs, then 1/2 turn more CW (approximately three threads showing). Fill the wet cup of Packing Nut 1/3 full of Throat Seal Oil (TSO).

i. Run unit at full pressure, release pressure and repeat step h.

GEARBOX SLEEVE BEARING REPLACEMENT

FIGURE 11

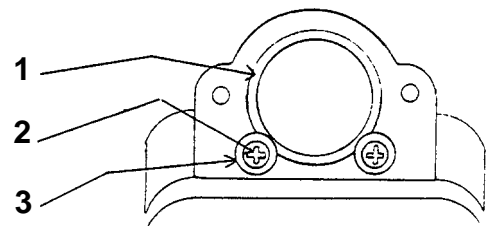

Note: When replacing item (1), cover the outside of sleeve with clear silicone prior to inserting into cover assembly.

FIGURE 11 PARTS LIST

ITEM NO.	PART NO.	DESCRIPTION
1	331-061	Sleeve Bearing
2	331-103	Washers (2)
3	331-197	Screws (2)

GEAR AND PUMP ASSEMBLY

FIGURE 12

Part No. 331-340 (2600 Hi)

Part No. 331-008 (2600 Lo)

Part No. 331-007 (2500)

Part No. 331-009 (2400)

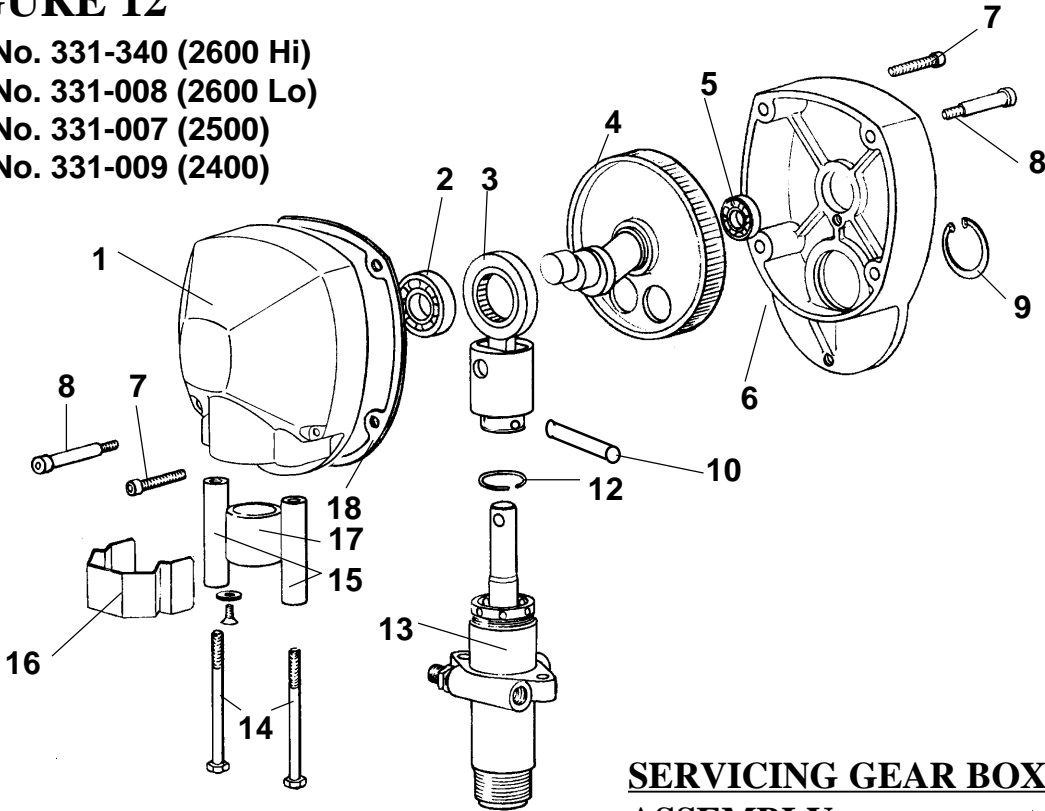

SERVICING GEAR BOX ASSEMBLY

1. Remove fluid pump as per "Fluid Pump Disconnect" procedures page 21.
2. On 2400 & 2500 remove handle (Fig. 17, Item 2) by removing two screws (Fig. 17, Item 3). On the 2600, detach frame by removing the four screws (Fig. 18, Item 7)
3. Refer to Fig. 12. Separate the cover assembly (1) from box (6) by removing bolts (7) from front of cover and back of box and shoulder bolts (8) from front of cover and back of box.
4. Lay unit on its back and disassemble gearbox.
5. Inspect bearings (2) and (5), Crosshead Assembly (3), Gearcrank (4) and sleeve bearing (17) inside cover assembly for wear or damage. Replace worn or damaged parts.
6. If gear grease needs replacing, replace with gear grease (Part No. 331-132)
7. Clean mating surfaces of cover and box thoroughly and attach self stick gasket (18).
8. Reassemble in reverse order.

* Note Box (Item 6) can be ordered separately, but is included with Motor Ass'y (PN 331-070, 331-068)

WARNING - Do not operate machine without cover guard in place.

FIGURE 12 PARTS LIST

ITEM NO.	PART NO.	DESCRIPTION
1	331-041	Cover Ass'y (2400,2500,2600 Lo)
	331-341	Cover Ass'y (2600 Hi)
2	331-046	Bearing
3	331-038	Crosshead Assembly
4	331-039	Gear Crank (2500)
	331-039A	Gear Crank (2400)
	331-039B	Gear Crank (2600)
5	331-047	Bearing
6	331-040	Box*
7	100-381	Bolt Soc Hd (2)
8	100-380	Shoulder Bolt (2)
9	331-088	Retaining Ring
10	331-065	Pin
12	331-062	Retaining Spring
13	331-209	Paint Pump Assembly-Lo-Boy
	331-236	Paint Pump Assembly-Hi-Boy
14	100-318	Screw (2)
15	331-074	Tube Spacer (2)
16	331-111	Cover - guard
17	331-061	Sleeve Bearing
18	331-219	Gasket

SERVICING PISTON ROD, UPPER CHECK VALVE

SEE FIG. 13

1. Disconnect Fluid Pump as per page 21.
2. Place piston in block (PN 331-195) with the 3/8" dowel pin (PN 331-196) and hold in vise.

NOTE: DO NOT use smaller diameter pin to hold piston.

3. Place a 7/16" allen wrench into lower piston and unscrew lower piston from upper piston. Clean all parts and inspect them carefully for wear and damage. Inspect the surface of piston for wear or damage. Replace these parts if needed.

4. To reassemble the piston assembly, place in block using dowel pin and hold in vise. Install O-ring (4), Seat (3) and Ball (2) and thread upper and lower pistons together. Slowly hand tighten piston then loosen piston and inspect that the O-ring (4) and seat (3), are flush, then torque to 50 ft. Do not use locktite on threads, but apply light coat of grease or anti-seize compound to threads.

NOTE: The upper and lower piston must be purchased as an assembly (Item 1, Fig 13). This assembly will not have the ball, seat and O-ring inside.

FIGURE 13

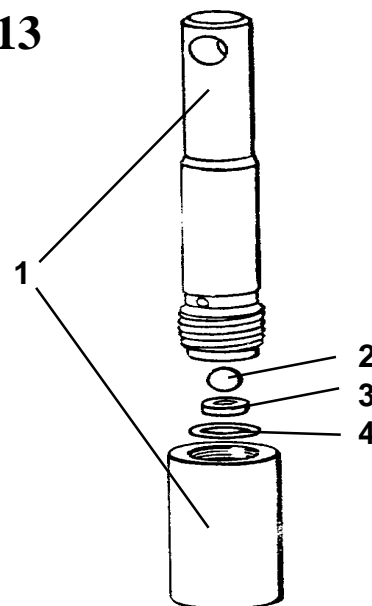
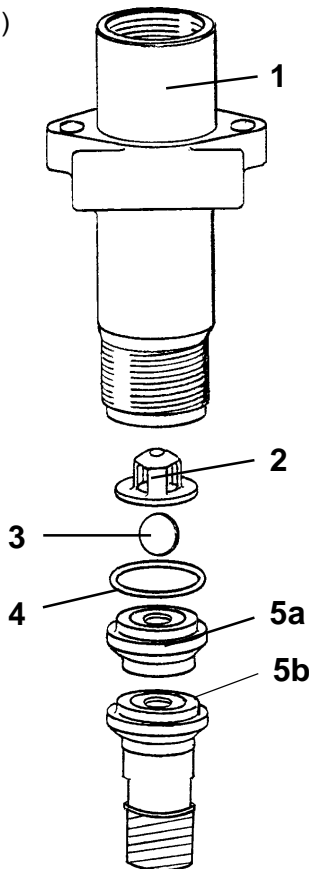

FIGURE 13 PARTS LIST		
ITEM NO.	PART NO.	DESCRIPTION
1	331-093	Piston Ass'y
2	331-027	Ball
3	331-026	Seat
4	331-100	O-Ring-PTFE

SERVICING LOWER SUCTION VALVE

1. Unthread suction nut (Fig. 21, Item 2) and remove suction assembly from pump body.
2. Remove suction seat assembly, O-ring, ball and retainer.
3. Clean all parts and inspect them for wear or damage, replacing parts as needed.



4. If lower seat need replacing, you must replace the suction seat assembly. (PN 331-033A Lo-Boy, PN 331-292 Hi-Boy)
5. Clean inside of pump body.
6. If no further pump service is needed, reassemble the lower check valve assembly, by placing the suction seat assembly, O-ring, ball and retainer in the suction nut and screw nut onto pump body. Tighten suction nut with rod tool (189-211).

FIGURE 14

FIGURE 14 PARTS LIST		
ITEM NO.	PART NO.	DESCRIPTION
1	331-011	Pump Body
2	331-029	Retainer
3	331-030	Ball 1/2" Dia.
4	331-032T	O-Ring - PTFE
5a	331-033A	Suction Seat Ass'y (Lo-Boy)
5b	331-292	Suction Seat Ass'y (Hi-Boy)

V-PACKING REPLACEMENT

DISASSEMBLY

1. Remove the Fluid Pump as per "Fluid Pump Disconnect" instructions on page 18.
2. Unscrew the packing nut and suction assembly. Push piston rod out through bottom of pump body. Remove the upper packings, belleville springs, tube spacer and lower packing set using packing removal tool (PN 331-153).
3. Disassemble and clean all parts for reassembly. Discard old packings, adaptors and O-Rings.

REASSEMBLY

1. Lubricate piston rod with oil or grease.
2. Soak leather packings in throat seal oil or other light-weight oil for 10-15 minutes.
3. Reassemble all parts onto piston rod in following order as per Fig.15 & 16:
 - a. Start with lower male adaptor (15)
 - b. Five V-Packings (16 & 17), "V" inverted.
 - c. Female adaptor (18).
 - d. Five V-Packings (16& 17), "V" up.
 - e. Male Adaptor (15)
 - f. Slide on tube spacer (10).
 - g. Three Belleville Springs (9) starting with the first spring facing down (\wedge), second one facing up (\vee), and the third one facing down (\wedge).
 - h. Upper male adaptor (8).
 - i. Five V-Packings, "V" inverted (6 & 7).
 - k. Place O-rings (3 & 4) onto seal holder (2)
 - l. Lubricate outside diameter of V-packings with white lithium or multipurpose grease.
 - m. Slide seal holder (2) over Upper Packing Set.
 - n. Lubricate threads on inside of pump body with white lithium or Multipurpose grease.
4. Hold pump body in one hand upside down and slide entire piston assembly with packings up into pump body. While inserting piston and packing assembly,
5. Install packing nut, handtight only. Push piston rod up to its upper position.
6. Connect the fluid pump onto Unit as per "Fluid Pump Reinstall" Procedures on page 21.

FIGURE 15

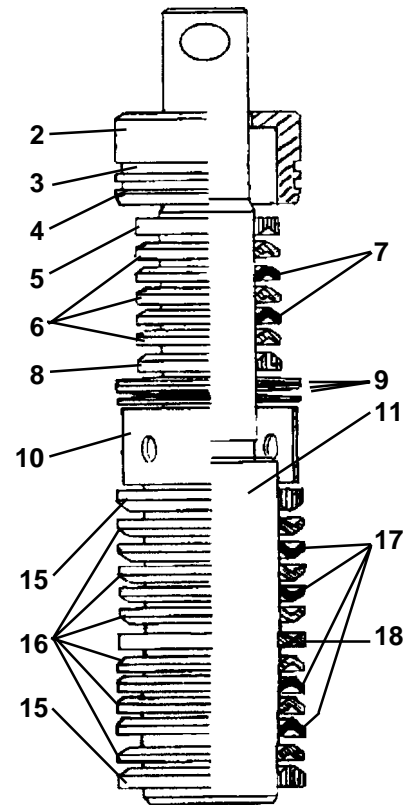

FLUID PUMP - PN. 331-209 (2400, 2500, 2600 Lo-Boy)

FIGURE 16

PN. 331-236 (2600 Hi-Boy)

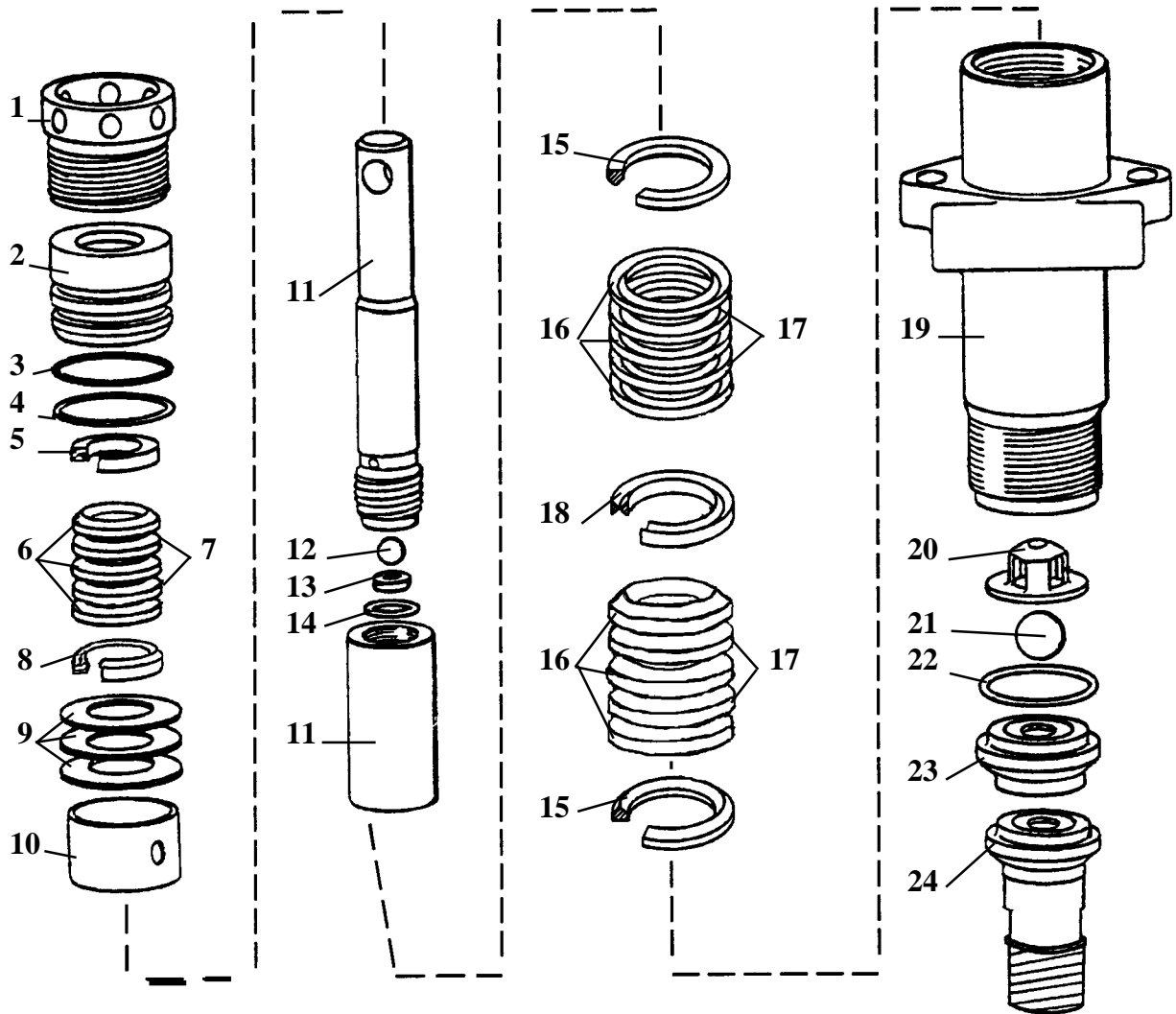

FIGURE 15 & 16 PARTS LIST					
ITEM NO.	PART NO.	DESCRIPTION	ITEM NO.	PART NO.	DESCRIPTION
1	331-037	Packing Nut	13	331-026	Seat
2	331-019	Seal Holder	14*	331-100	O-Ring PTFE
3*	331-020V	O-Ring Viton	15*	331-014	Adapter Male(2)
4*	331-020T	O-Ring PTFE	16*	331-016	V-Packing-Plastic (6)
5*	331-021	Adapter Female	17*	331-016L	V-Packing-Leather(4)
6*	331-023	V-Packing-Plastic (3)	18*	331-015D	Adapter Female
7*	331-023L	V-Packing-Leather (2)	19	331-011	Fluid Body
8*	331-022	Adapter Male	20	331-029	Retainer
9	331-025	Belleville Springs (3)	21*	331-030	Ball
10	331-018	Tube Spacer	22*	331-032T	O-Ring PTFE
11	331-093	Piston Assembly	23	331-033A	Seat Lo-Boy
12*	331-027	Ball	24	331-292	Seat Hi-Boy
			*	331-210	Packing Kit

MACHINE ASSEMBLY 2400/2500

FIGURE 17

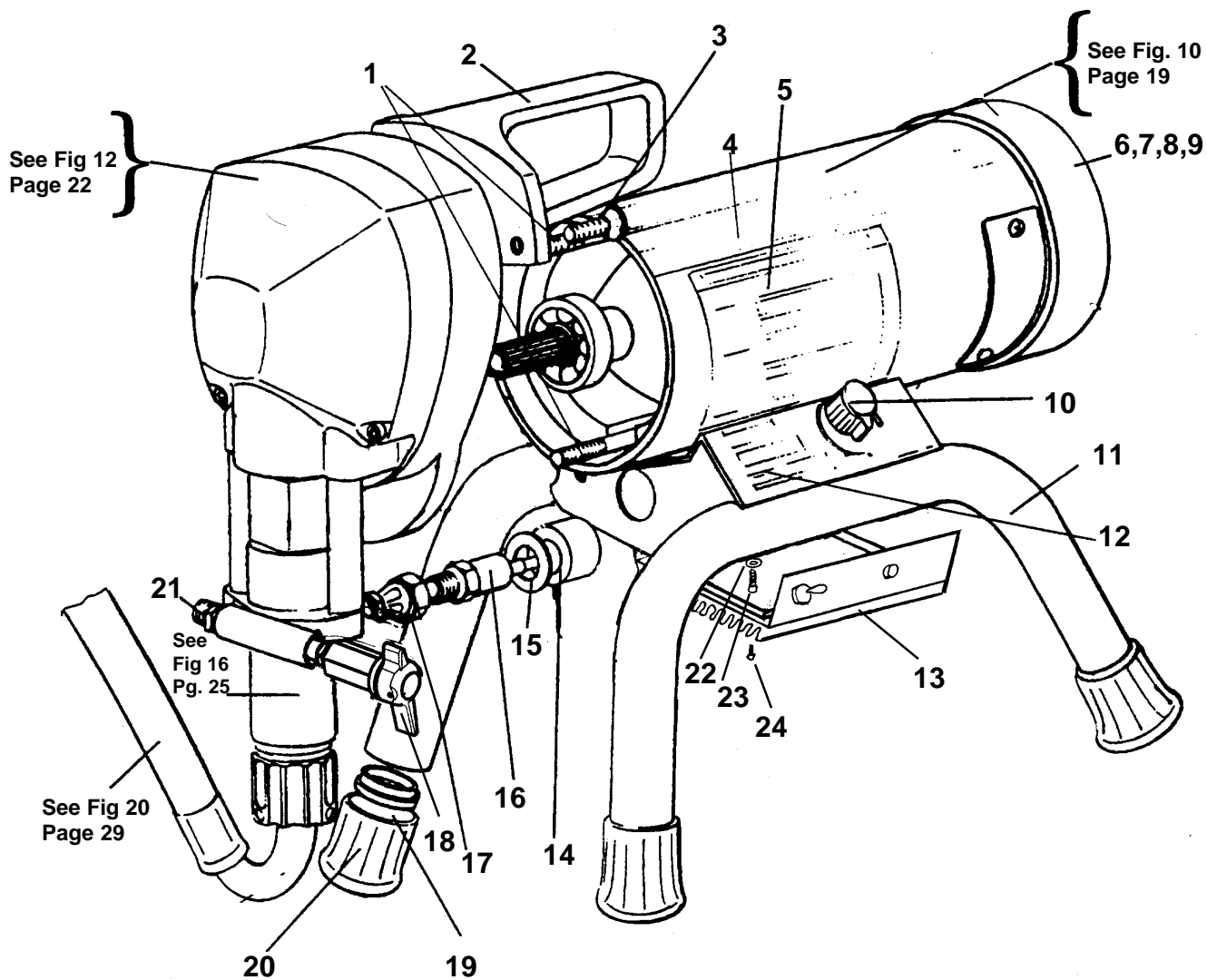

FIGURE 17 PARTS LIST

ITEM NO.	PART NO.	DESCRIPTION	ITEM NO.	PART NO.	DESCRIPTION
1	331-216	Motor Screw (2400)	13	331-315	Pressure Control Ass'y
	331-215	Motor Screw (2500)	14	331-151	Seal
2	331-079	Handle	15	114-009R	Washer, Nylon
3	100-377	Screw - Torque (T-27)	16	331-294	Sensor
4	101-107	Label (2400)	17	100-003	Swivel Connector
	101-108	Label (2500)	18	100-180	Prime/Pressure Relief Valve
5	101-005	Label - Warning	19	331-094	Plug (4)
6	331-212	Fan	20	331-048	Rubber Boot (4)
7	331-213	Fan Cover	21	115-019	Hose Connector
8	117-090	Screw (3)	22	331-103	Washer (4)
9	331-070	Motor (2400)	23	100-312	Screw (4)
	331-068	Motor (2500)	24	111-037	Screw (4)
10	117-044	Knob			
11	331-344	Frame Ass'y			
12	101-069	Label (2400, 2500)			

MACHINE ASSEMBLY - 2600 LO-BOY

FIGURE 18

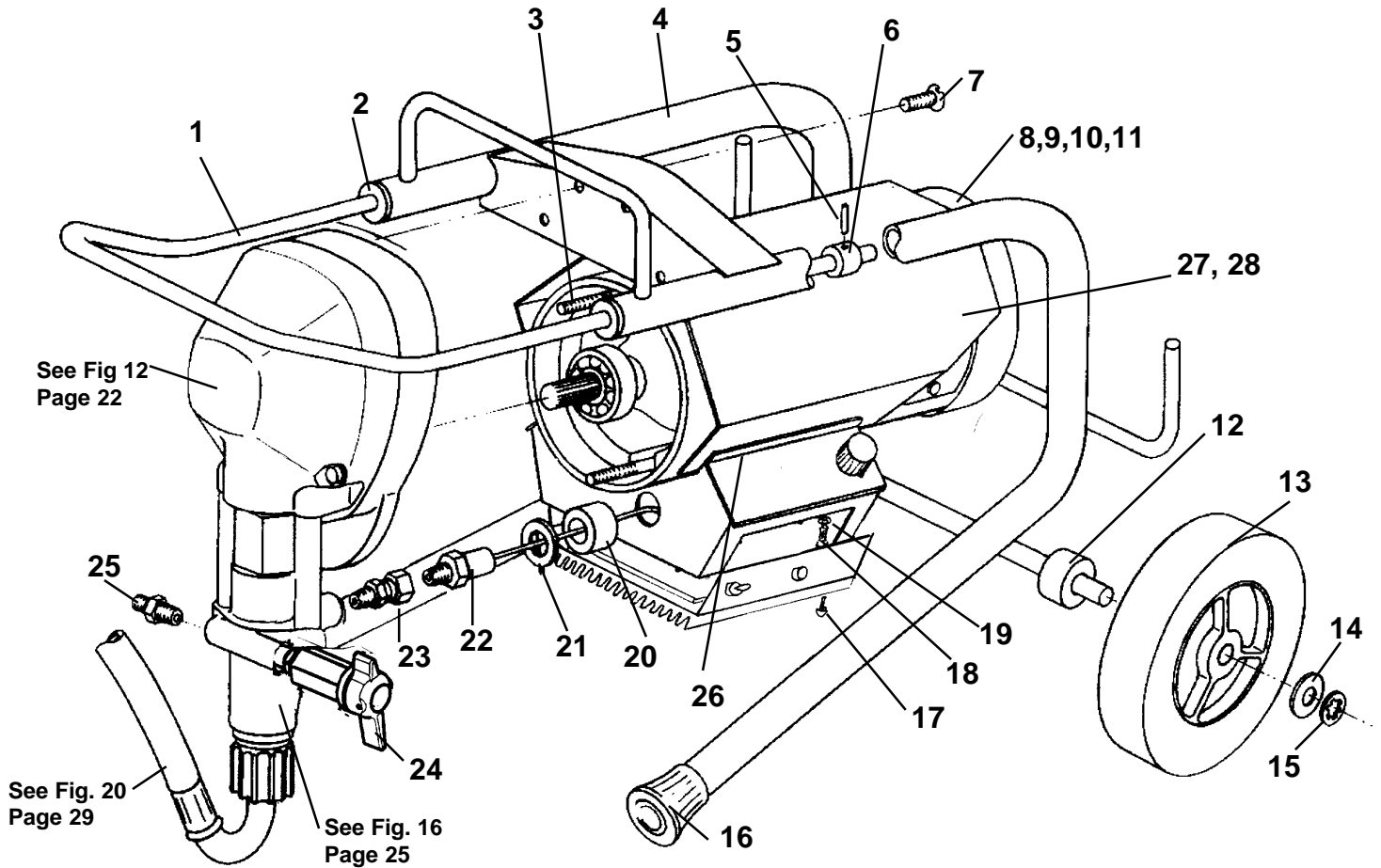

FIGURE 18 PARTS LIST

ITEM NO.	PART NO.	DESCRIPTION	ITEM NO.	PART NO.	DESCRIPTION
1	331-174	Handle	15	143-032	Retaining Ring (2)
2	331-176	Bushing (2)	16	331-048	Rubber Boot (2)
3	331-215	Motor Screw (2)	17	111-037	Screw (4)
4	331-171	Frame	18	100-312	Screw (4)
5	331-222	Roll Pin (2)	19	331-103	Washer (4)
6	331-175	Spacer (2)	20	331-151	Seal
7	100-377	Screw-Torq. (T-27)	21	114-009R	Washer
8	331-212	Fan	22	331-294	Sensor
9	331-213	Fan Cover	23	100-003	Swivel Connector
10	117-090	Screw (3)	24	100-180	Prime/Pressure Relief Valve
11	331-068	Motor	25	115-019	Hose Connector
12	113-030	Spacer (2)	26	331-178	Rubber Extrusion
13	331-189	Wheel (2)	27	331-199US	Motor Cover
14	143-028	Washer (2)	28	101-134	Label (2600)

LP2600 HI-BOY FRAME

FIGURE 19

FIGURE 19 PARTS LIST		
ITEM	PART NO.	DESCRIPTION
1	331-273	Frame
2	331-289	Spacer (2)
3	113-017	Wheel (2)
4	143-028	Washer (2)
5	143-032	Retaining Ring (2)
6	331-048	Rubber Boot (2)

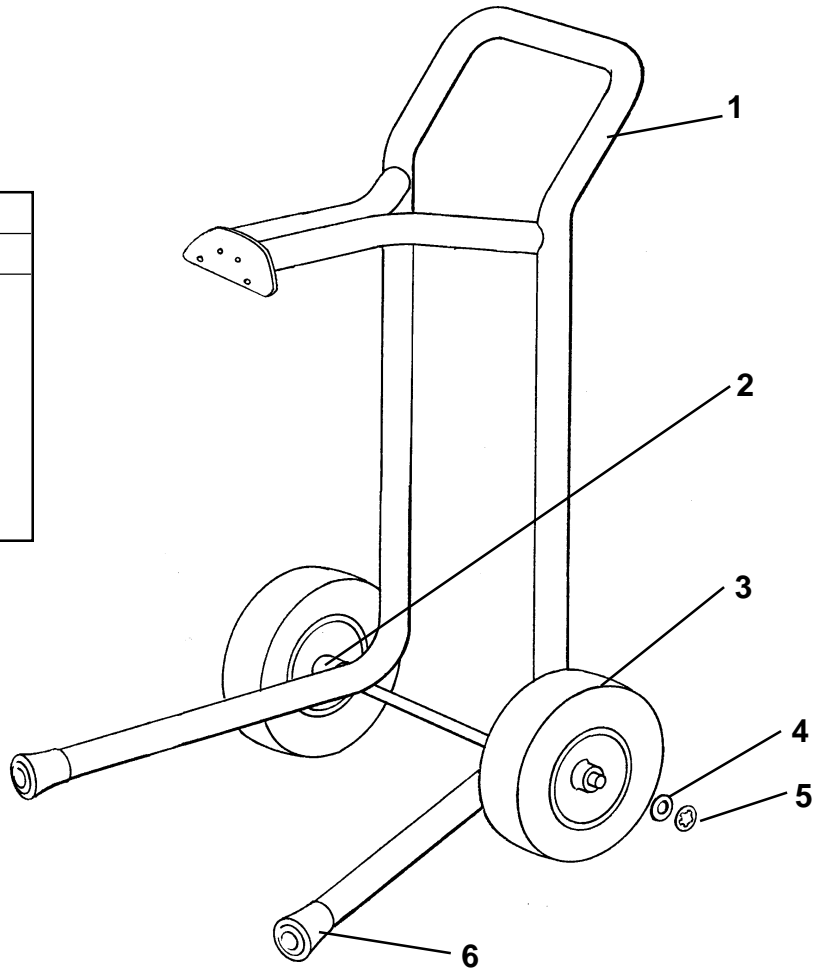

SUCTION ASSEMBLIES

SUCTION ASSEMBLY PARTS, MODELS 2400, 2500 & 2600 (Lo-Boy)

PART NO. 331-238

FIGURE 20

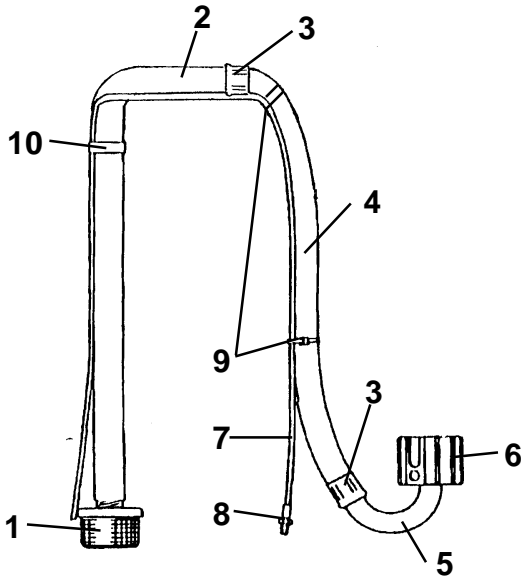

FIGURE 20 PARTS LIST		
ITEM NO.	PART NO.	DESCRIPTION
1	331-217	Inlet Strainer
*	331-290	Suction Hose Ass'y Incl. Items 1,2,3,4,5,6
2	331-384	Suction Tube
3	331-281	Ferrule
4	331-383	Suction Hose
5	331-035	Suction Elbow
6	331-034	Suction Nut
*	331-231	Bypass Hose Ass'y Incl. Items 7 & 8
7	111-013	Bypass Hose
8	331-090	Fitting
9	111-016	Nylon Tie
10	331-135	Spring Clip

SUCTION ASSEMBLY PARTS

FIGURE 21

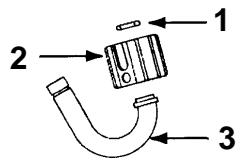

FIGURE 21 PARTS LIST		
ITEM NO.	PART NO.	DESCRIPTION
1	331-036T	O-Ring, PTFE
2	331-034	Nut - Suction
3	331-035	Elbow- Modified

MODEL 2600 HI-BOY SUCTION ASSEMBLY, PART NO. 331-272

FIGURE 22

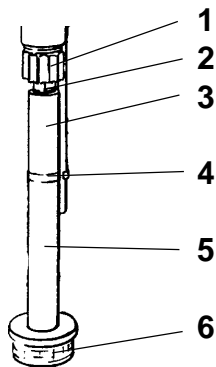

FIGURE 22 PARTS LIST		
ITEM NO.	PART NO.	DESCRIPTION
1	331-034	Suction Nut
2	331-292	Suction Seat Ass'y
3	331-237	Bypass Hose
4	331-135	Spring Clamp
5	331-285	Inlet Tube
6	141-008	Filter