

SWIVEL WHEEL ASSEMBLY - P.N. 305-260

FIGURE 18

- 100-318 Screw 5/16-18 x 3.75L
- 100-393 Screw 6-32 x 2.0L
- 100-394 Cap Screw 3/8 - 16x2.75L
- 100-395 Cap Screw 3/8- 16 x 5.0L
- 112-008 Flanged Bearing
- 113-021 Cotter Pin
- 119-035 Nut 3/8- 16
- 136-223 Spring
- 136-230 Axle 5/8 x 5.50L
- 139-337A Wheel
- 140-035 Washer .670 x .370
- 140-053 Washer M18 x 3.0
- 140-055 Washer .375 x 2.0
- 143-029 Set Collar
- 260-029 Castle Nut
- 305-092 Cable Assembly
- 305-105 Lever
- 305-193 Spacer
- 305-253 Swivel Clamp
- 305-254 Swivel Frame
- 305-255 Adjustment Sleeve
- 305-256 Pivot Washer
- 305-257 Swivel Lock Pin
- 305-258 Swivel Lock
- 305-259 End Lug
- 305-261 Cable Holder

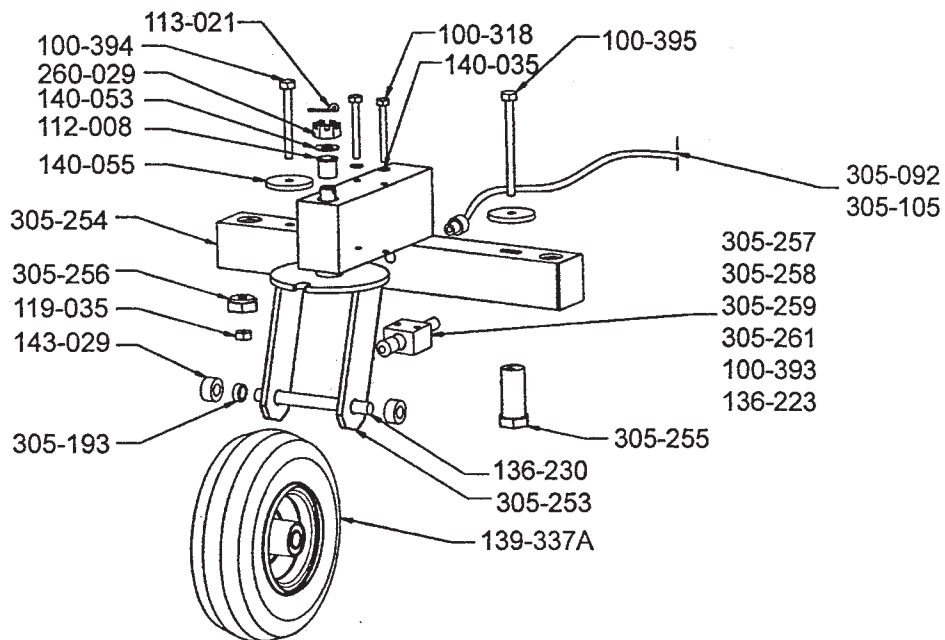

SUCTION ASSEMBLY - P.N. 331-227

FIGURE 19

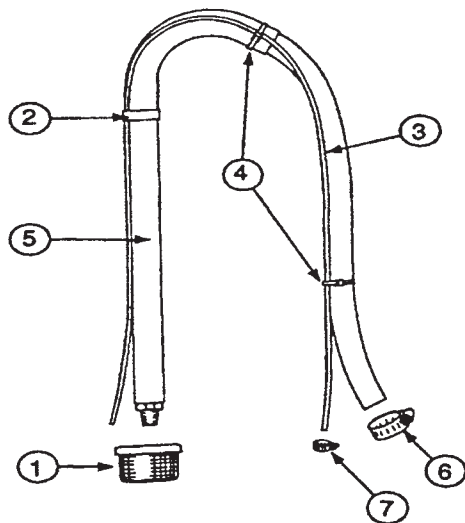

FIGURE 19 PARTS LIST		
ITEM NO.	PART NO.	DESCRIPTION
1	331-217	Filter 16 mesh
2	331-135	Spring Clamp
3	331-137	Prime Hose (38")
4	111-016	Nylon Strap (2)
5	331-226	Suction Hose Ass'y
6	111-015M	Hose Clamp
7	141-015	Hose Clamp