



Wastewater and Water Industry

Material and Equipment for the maintenance and support of the water industry



► Surface Preparation Equipment for Water & Wastewater Treatment

Clean Surfaces and Create an SSD

Surface preparation is vital in highly corrosive environments and impacts the performance of a coating. Increase production while reducing dust by up to 92 percent over dry blasters with an EcoQuip Vapor Abrasive blaster.

Small Portable Projects

EcoQuip® 2 EQp

This powerful machine can blast up to 150 psi and is optimized to work well with a 185 cfm compressor. In addition, it can blast for up to 90 minutes between refills.

- Low water usage, less mess – uses less than 1 qt/min of water
- Blast pressures up to 150 psi (10.3 bar)
- Pot size of 2.0 cubic ft (57 L) - holds approximately (4) 55 lb bags of media



Medium to Large

EcoQuip® 2 EQs

This high-production, standalone unit was designed to tackle most typical blasting projects and can easily be transported from one jobsite to another. In addition, EcoQuip 2 blasters use less water than slurry or other water-based technologies so pools of water aren't left behind and there is less need to worry about toxic runoff.

- Fits inside a 6 ft truck bed for easy transport
- Coated crash frame and enclosure
- 6.5 cubic ft (184 L) pot - holds approximately (16) 55 lb bags of media



Large Projects

EcoQuip 2 EQs Dual Line

Graco's EcoQuip EQs Dual Line features two outlets and a large pressure pot capable of blasting up to four hours with two blasters at once. Add the 120 gallon water tank to the skid for job sites without a pressurized water source and get up and running quickly with this high production machine.

- Fits inside a truck bed for easy transport
- Unrestricted fill opening allowing for 2x faster loading than regular skid model
- Fully coated frame that has a durable, welded design for robust environments
- One 12 cubic ft (340 L) blast pot – holds approximately (30) 55 lb bags of media



► Mortar Equipment for Water & Wastewater Treatment

Repair Structures Quickly

Concrete is porous and susceptible to cracking, so it's important you have the right equipment to properly repair and protect it.

Select one of Graco's portable, easy-to-use ToughTek mortar sprayers and get the job done quickly.

SW CONCRETE



Dura-Plate 2300

Three component, epoxy modified cementitious resurfacer. It is used for resurfacing, patching and filling voids (bugholes) in concrete and masonry structures. Provides a hard durable surface with excellent adhesion that minimizes outgassing problems typically associated with coating concrete.

ToughTek® M680a

The air powered ToughTek M680a piston pump handles abrasive materials such as epoxy mortars or cementitious materials, tackles difficult polymers with fillers such as glass flake, silica or sand.

AW COOK CONCRETE



AW Cook Repair Mortar

A.W. Cook has a full line of vertical and horizontal repair mortars. Sherwin-Williams will help you select the right product for repair of existing brick and concrete manholes prior to receiving chemical coatings and to stop water infiltration and exfiltration.

ToughTek® M680a

The air powered ToughTek M680a piston pump handles abrasive materials such as epoxy mortars or cementitious materials, tackles difficult polymers with fillers such as glass flake, silica or sand.

ToughTek® S340e

Engineered with Graco's proprietary piston pump technology, the ToughTek S340e plugs into a standard 120V outlet. Handles repair mortars with small to medium sized aggregate.

ToughTek® P20

The ToughTek P20 rotor stator pump is ideal for medium sized plaster applications as well as small jobs like pointing, or filling the spaces between stone or grout.

► Protective Coatings Equipment for Water & Wastewater Treatment

Spray 100% Solids with Ease

Having the right coatings and sprayer to protect metal and concrete from corrosive chemicals and other acidic compounds is critical. No matter which Sherwin-Williams material is needed for your next project, Graco has a wide selection of single-leg and plural component sprayers to meet your needs.



SINGLE LEG



Dura-Plate 6000

- Glass flake reinforced
- Hangs up to 125+ mils (3,125 microns)
- Extended 21 day re-coat window
- Return to service in 10 hours
- Extremely low permeability
- May be applied to an SSD (Saturated Surface Dry) substrate



King®

This dependable, durable and rugged airless protective coatings sprayer is easy to maintain and will get the job done quickly and efficiently.

PLURAL COMPONENT



Dura-Plate 6000

- Glass flake reinforced
- Hangs up to 125+ mils (3,125 microns)
- Extended 21 day re-coat window
- Return to service in 10 hours
- Extremely low permeability
- May be applied to an SSD (Saturated Surface Dry) substrate



Dura-Plate 6100

- 100% solids
- Low VOC
- Resistant to water and wastewater treatment immersion
- Resistant to Sulfuric Acid formation caused by MIC in wastewater environments
- May be applied to an SSD (Saturated Surface Dry) substrate
- May be applied as a mortar system using type DP aggregate



Poly-Cote 115

- For small fittings, valves and elbows
- Developed specifically for tight work spaces
- Provides a 24 hour recoat window



XP

Get your crew up and running quickly with this easy-to-operate pump. Engineered to proportion with two pumps instead of three, the Graco XP reduces your cost of ownership with fewer components.



XM

The XM Sprayer provides precise ratio control, allows users to download historical spraying data, and handles a wide range of two-component materials.

► Protective Coatings Equipment for Sewer Collection

Dependable, Easy-to-use Sprayers

Whether it's a lift station, manhole or wet-well, Graco's equipment helps your business get the job done quickly so the sewer collection system can get back into operation. Select one of these epoxy coatings with a reliable Graco sprayer for maximum protection of concrete and steel surfaces.

SINGLE LEG



Dura-Plate 6000

- Glass flake reinforced
- Hangs up to 125+ mils (3,125 microns)
- Extended 21 day re-coat window
- Return to service in 10 hours
- Extremely low permeability
- May be applied to an SSD (Saturated Surface Dry) substrate



King®

This dependable, durable and rugged airless protective coatings sprayer is easy to maintain and will get the job done quickly and efficiently.

PLURAL COMPONENT



Dura-Plate 6000

- Glass flake reinforced
- Hangs up to 125+ mils (3,125 microns)
- Extended 21 day re-coat window
- Return to service in 10 hours
- Extremely low permeability
- May be applied to an SSD (Saturated Surface Dry) substrate



Dura-Plate 6100

- 100% solids
- Low VOC
- Resistant to water and wastewater treatment immersion
- Resistant to Sulfuric Acid formation caused by MIC in wastewater environments
- May be applied to an SSD (Saturated Surface Dry) substrate
- May be applied as a mortar system using type DP aggregate



XP

Get your crew up and running quickly with this easy-to-operate pump. Engineered to proportion with two pumps instead of three, the Graco XP reduces your cost of ownership with fewer components.



XM

The XM Sprayer provides precise ratio control, allows users to download historical spraying data, and handles a wide range of two-component materials.

► Protective Coatings Equipment for Water Storage Tanks

Consistently Spray Accurately and On-Ratio

When protecting the linings inside water storage tanks, select a 100% solid coating for higher film build so you can get the job done in one coat while extending the life cycle and meeting strict VOC rules. Pair one of these coatings with Graco's reliable, easy-to-use equipment and get water tanks put back into operation quickly, minimizing nuisances to nearby neighborhoods.

SINGLE LEG



Dura-Plate 6000

- Glass flake reinforced
- Hangs up to 125+ mils (3,125 microns)
- Extended 21 day re-coat window
- Return to service in 10 hours
- Extremely low permeability
- May be applied to an SSD (Saturated Surface Dry) substrate



Macropoxy 5500LT

- Low odor, Low VOC
- Outstanding application properties
- Recommended for potable water
- Capable of low temperature cure



King®

This dependable, durable and rugged airless protective coatings sprayer is easy to maintain and will get the job done quickly and efficiently.



e-Xtreme® Z60

The Z60 is an electric alternative to air-operated sprayers and is capable of up to 6000 psi. Switch to electric for a quiet, dependable sprayer that only requires 240V, single phase power.

PLURAL COMPONENT



Dura-Plate 6000

- Glass flake reinforced
- Hangs up to 125+ mils (3,125 microns)
- Extended 21 day re-coat window
- Return to service in 10 hours
- Extremely low permeability
- May be applied to an SSD (Saturated Surface Dry) substrate



SherPlate PW

- One or two coat protection
- Fast return to service
- Low VOC
- Low odor
- Dry to walk-on within four hours
- Designed for plural-component application equipment
- Greater than 70% edge build retention
- NSF approved to standard 61 for potable water



Poly-Cote 115

- For small fittings, valves and elbows
- Developed specifically for tight work spaces
- Provides a 24 hour recoat window



XP

Get your crew up and running quickly with this easy-to-operate pump. Engineered to proportion with two pumps instead of three, the Graco XP reduces your cost of ownership with fewer components.



XM

The XM Sprayer provides precise ratio control, allows users to download historical spraying data, and handles a wide range of two-component materials.

► Custom Solutions for Your Next Job

Engineered Solutions That Meet Your Unique Demands

Whether you have a new coating to spray that requires a custom configuration or need a specific set up for your next job site, Graco has you covered. Our team of engineers are ready to help you find the right solution for your next project so you can get the job done on time and without complications.

Cart Design

Mobile

A mobile cart gives you the power and adaptability to handle most medium to large scale jobs with ease. If you have a special need for this type of mobile design, let our engineers help you with the right custom solution.

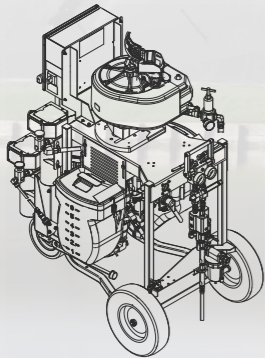

CUSTOM SOLUTION

Skid Design

Stationary

A skid solution gives you everything you need to handle large scale jobs with ease. No matter how specialized the solution, Graco has the capabilities to meet your needs.

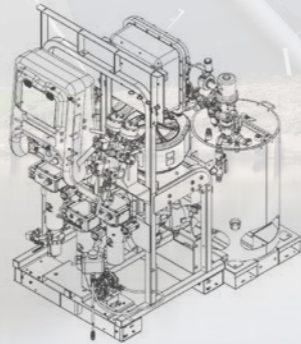

CUSTOM SOLUTION

For more information or to request a quote, visit graco.com/customquote



GRACO HEADQUARTERS

WORLDWIDE HEADQUARTERS

Graco Inc.
88 -11th Avenue N.E.
Minneapolis, MN 55413
Tel: 612-623-6000



Graco Has You Covered

Facilities Worldwide for Global Support



Commitment to Quality Since 1926

When you choose Graco, you're investing in high-quality products built to last for years of reliable service. Moreover, we partner with our customers to better understand how you're deploying our products in the field, then use your experiences to improve performance and durability. Our goal is to exceed your quality expectations for equipment longevity, reliability and performance every day.



Local Distribution and Support

Graco partners with authorized distributors across the globe to provide you with local sales and service support, application expertise and availability of inventory. Graco's has dedicated field experts in all areas of the world to support the products we sell so you can be assured of getting the answers you need when you need them.



Customer Service You Can Count On

No matter where your team is in the world, we strive to provide the best customer service in the industry. We call it Graco's A+ Service. Graco's A+ Service philosophy is our promise to only deliver top-shelf (A+) service to every customer, every time. We'll listen to the situation and work to resolve it as quickly as we can.

Contact us today!