



Viscount® I+ 225, 300, 450

Hydraulic Mid-Range Piston Pump

Viscount pumps, utilizing midrange High-Flo pump lowers, provide reliable, quiet, ice-free performance and are up to three times more energy efficient than comparable compressed air systems.

- Positive displacement, 4 ball piston design provides large output per cycle for reduced pump wear
- Small displacement rod design reduces sealing area to minimize throat leakage
- Gentle pumping action produces a low shear output for shear sensitive materials
- Stainless steel and Severe Duty carbon steel models available to handle a variety of fluids

Dimensions

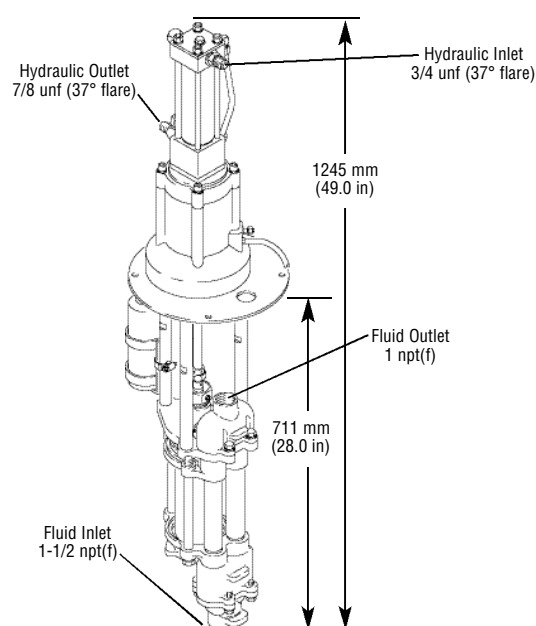

Technical Specifications

	Viscount I+ 225	Viscount I+ 300	Viscount I+ 450
Maximum fluid outlet pressure	16 bar, 1.6 MPa (225 psi)	21 bar, 2.1 MPa (300 psi)	31 bar, 3.1 MPa (450 psi)
Maximum hydraulic input pressure	103 bar, 10.3 MPa (1500 psi)	103 bar, 10.3 MPa (1500 psi)	103 bar, 10.3 MPa (1500 psi)
Oil flow @ 60 cpm	13.2 lpm (3.5 gpm)	13.2 lpm (3.5 gpm)	11.3 lpm (3 gpm)
Fluid flow @ 60 cpm	75.6 lpm (20 gpm)	53.9 lpm (14.2 gpm)	36.4 lpm (9.6 gpm)
Volume per cycle	1.23 l (0.33 gal)	0.90 l (0.24 gal)	0.61 l (0.16 gal)
Sound pressure level @1500 psi oil @ 20 cpm	78 dBA	78 dBA	78 dBA
Hydraulic fluid inlet	3/4 in (37° flare)	3/4 in (37° flare)	3/4 in (37° flare)
Hydraulic fluid outlet	7/8 in (37° flare)	7/8 in (37° flare)	7/8 in (37° flare)
Pump fluid inlet	1-1/2" npt(f)	1-1/2" npt(f)	1-1/2" npt(f)
Pump fluid outlet	1" npt(f)	1" npt(f)	1" npt(f)
Weight	35 kg (76 lb) CS 32 kg (69 lb) SST	35 kg (76 lb) CS 32 kg (69 lb) SST	35 kg (76 lb) CS 32 kg (69 lb) SST
Instruction manual	311211	311211	308793

Ordering Information

Viscount 1+ 225	Viscount 1+ 300	Viscount 1+ 450	Lower Material	Piston Rod	Seals	Fitting
253647	253646	236601	CS	Chromex	UHMWPE/ Leather	NPT
253643	253642	236602	SST	Chromex	UHMWPE/ Leather	NPT
253645	253644	–	SST	Maxlife	UHMWPE/ Leather	NPT
–	–	244142	SST	Chromex	PTFE	NPT
253649	253648	–	SST	Chromex	UHMWPE/ Leather	BSPP
253651	253650	–	SST	Maxlife	UHMWPE/ Leather	BSPP
253653	253652	–	SST	Chromex	UHMWPE/ Leather	Tri-Clamp
253655	253654	–	SST	Maxlife	UHMWPE/ Leather	Tri-Clamp

Standard Kits

Viscount 1+ 225	Viscount 1+ 300	Viscount 1+ 450	Description
277362	277360	220589	UHMWPE piston seal kit
277357	277357	239872	UHMWPE/Leather throat seal kit
–	–	181898	Chrome piston rod
15H280	15H280	–	Chromex piston rod
15H589	15H589	–	Maxlife piston rod
183048	183047	183049	Chrome cylinder
15H453	15H452	–	Maxlife cylinder
–	–	685971	Ceramic cylinder
181900	183032	181899	Nitride cylinder (cs)

Optional Kits

Viscount 1+ 225	Viscount 1+ 300	Viscount 1+ 450	Description
277363	277361	224934	PTFE piston seal kit
239866	239866	239866	PTFE throat seal kit
277356	277356	239868	Leather throat seal kit

Accessories

206221	Wall mount bracket
220581	Floor stand
110335	Packing wrench
189305	Assembly tool yoke/trip rod
261721	Wet cup booster cup