

Force Feed Box Lubricators



Manzel Pumping Packages

FORCE FEED BOX LUBRICATOR = true modularity

Wide choice of standard modular components helps you meet application requirements more exactly without the added costs of a custom system.

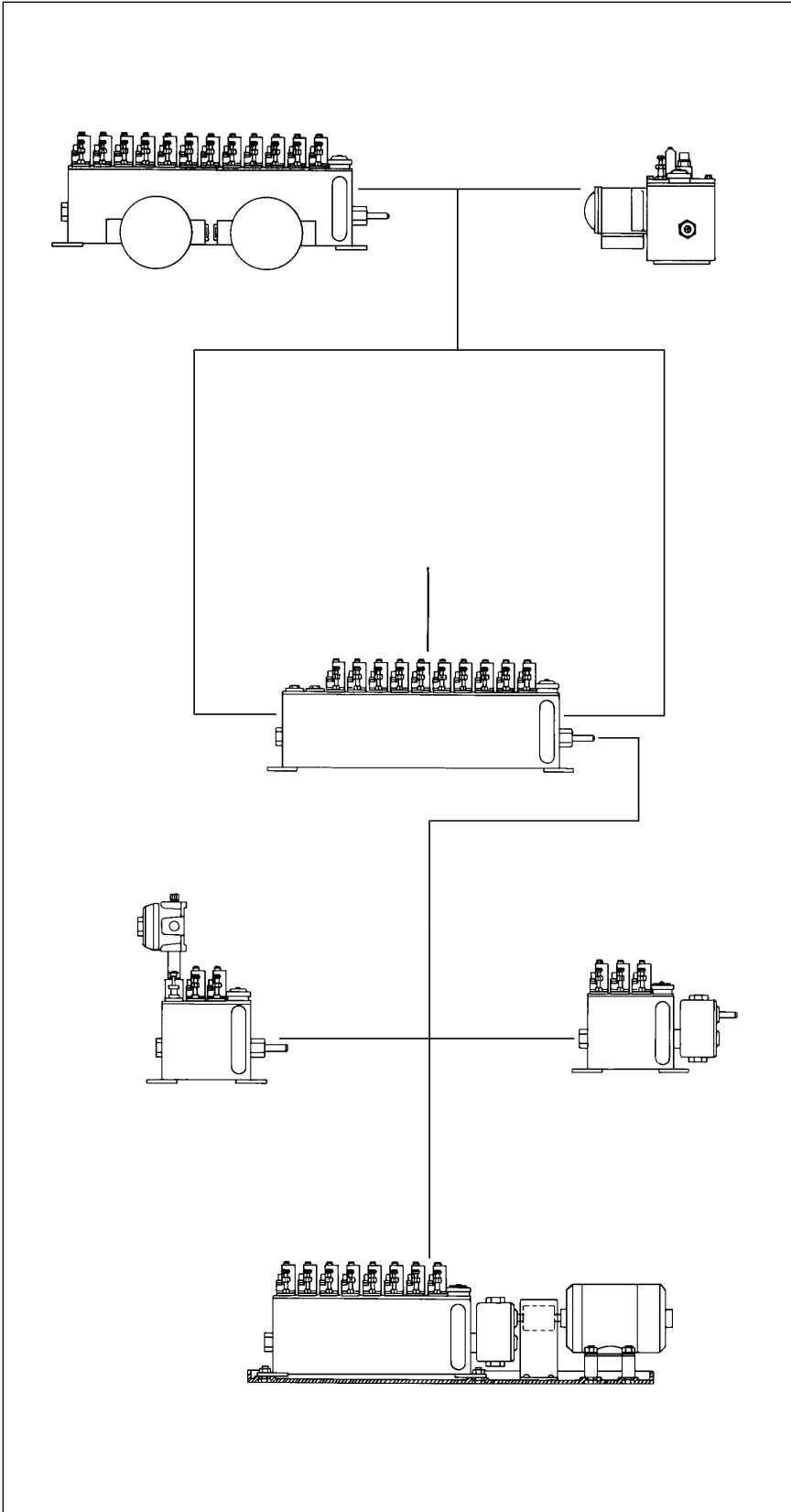

RESERVOIR ACCESSORIES -

Automatic fill, low level, and electric and steam heater options. For details see page 12 thru 15.

PUMPS -

Two pump styles are available for use in the Manzel Model MBL Box Lubricator. The first is the Model 88 Pump (reference literature 51025), which is ideal for light - medium duty applications. The model 88 pump is interchangeable with pumps from competitive lubricators. The second offering is the Model 76 Pump (reference literature 51021), which is ideal for heavy-duty applications. Both styles of pump provide pressures up to 7,500 PSI for mineral or synthetic oils. See complete details in reference literature.

RESERVOIRS -

Eight reservoir capacities are available to hold from 4 to 40 pints and accommodate from 1 to 24 pumps. Blank cover assemblies are available for unused pump stations. For details see pages 4 and 5.

SHAFT ROTATION ALARMS -

Three shaft rotation alarm options are available. These options use one pump station on the reservoir and are available with SPDT or DPDT switches or without a switch. For details see page 14

DRIVE OPTIONS -

Eighteen drive options are available from direct drive to a reduction ratio of 400:1. Options provide left- or right-hand end of reservoir mounting, end or rear rotary drives, end ratchet drives and gear reducers. For details see pages 8, 9, and 10.

MOTOR AND MOTOR MOUNTING BASE OPTIONS -

Single- and three-phase motors are available at ratings of 1/3, 1/4 and 1/2 hp, for 115/230 volt or 230/460 volt, an explosion-proof, TEFC or TENV configuration. Some motor configurations are available foot-mounted and/or face-mounted.

Eight sizes of motor mounting bases are available to accommodate the various reservoir sizes. For details see page 11.

INTRODUCTION

MODULARITY

Force Feed Box Lubricators provide true modularity that permits customizing a pump-to-point lubrication system from off-shelf components. The modular variables are shown on page 2 and consist of the following categories of components:

- Pumps
- Reservoir
- Reservoir Heaters
- Reservoir Oil Level Controls
- Drives
- Shaft Rotation Alarm
- Motor and Motor Mounting Bases

In addition to these Force Feed Box Lubricator components, Graco offers a complete line of auxiliary equipment. Also, Manzel pumping packages can be used with divider valves in a series progressive installation. Graco's performance-proven products that may be used with Modular Box Lubricators are listed below along with the respective literature number.

Literature	
L54000	Lube Line Alert
L14701	Lube Sentinel II Monitor
L15831	Lube Sentry
L44630	Lube Meter Panel
L15825	Check Valves
L15200	In-Line Filters
L10103	MH Modular Divider Valves

DESCRIPTION

A basic pump-to-point system is shown in the illustration which depicts six pumps mounted on a common reservoir from which each pump is dispensing oil to a single lubrication point. These pumps are operated by individual cams on the drive shaft.

FEATURES/BENEFITS

- Force Feed Box Lubricators provide a proven, cost-effective way to assemble customized oil systems that meet specific requirements by using standard modular components.
- Force Feed Box Lubricators increase opportunities to standardize lube system components and reduce lube maintenance and service costs.
- Force Feed Box Lubricators save you system design dollars and lead time.
- Force Feed Box Lubricators are dependable and backed by the industry's most comprehensive international distributor network — with application expertise, parts stocks and factory-trained service nearby, wherever you are located.

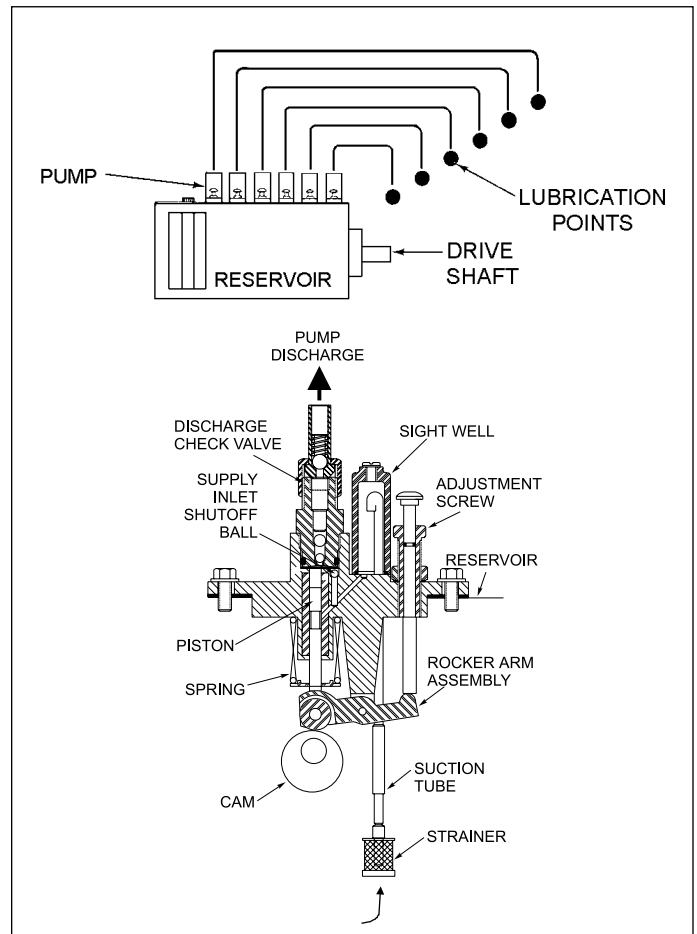

PUMP-TO-POINT SYSTEM

INTERCHANGEABILITY, CONVERSION AND RETROFITS

Graco Model 88 Pumps have been designed to be easily interchangeable with other manufacturers' pumps. For details contact your local Graco representative or call on us for system design and application assistance. At the factory and in the field through our network of distributors, we have unmatched experience in the design and effective application of lubrication systems. We also have in-depth know-how in the application of these systems in your specific industry.

APPLICATIONS AND INDUSTRIES

All working parts of the Force Feed Systems are totally enclosed away from dirt, water and impurities. And, each moving part is self-lubricated at all times by the fluid in the reservoir. This and the wide range of options, high discharge pressure and rugged construction plus the many other features and benefits make Force Feed Systems ideally suited for these applications and industries:

Application	Industry	Use
Com rs	Petrochemical, Refineries, Gas Transmission, Injection & Storage, Cold Storage, General Manufacturing, Air Systems	Lubricate cylinder walls and piston shaft packing
Edgers, Planers, Band Saws	Lumber	Lubricate sides and ways. Blade coolant (see note)
Note: Using lubricant as a coolant permits burning saw dust without drying.		
Mixers	Rubber	Used in the bleding process and to lubricate dust stop seals
Can Lid Presses	Food Processing	Lubricate high-speed bearings
Band Saws	Lumber	Saw guides

RESERVOIRS

DESCRIPTION

Eight reservoir styles are available for the Model 76/88 Pump. Each is ruggedly built to reduce deflection and provide longer life. The end plates supporting the shaft main bearings are heavy gage steel welded to the main body.

Camshaft intermediate support bearings are bottom mounted to an inside channel to provide maximum rigidity without adding length.

Each reservoir is equipped to handle the maximum number of pumps. Unused pump stations are covered with a gasket, blank cover assembly that can easily be removed to convert to an active pump station.

Additional pump stations are required for the following options:

- Automatic Fill Options F1 and F2
- Low Level Option L1
- Shaft Rotation and Low Level Alarm Options (S1, S2 and S3)

FEATURES/BENEFITS

- Rugged construction for durability
- Complete assembly - includes level sight gauge, fill cup and drain plug
- Versatile - permits mounting drive motor on right or left end
- Precise camshaft alignment insures proper lubrication by all pumps

Ordering Code	Tank Capacity (pts)	Max Pump Stations
T1	4	2
T2	6	3
T3	8	5
T4	12	8
T5	16	12
T6	24	16
T7	32	20
T8	40	24

DIMENSIONS

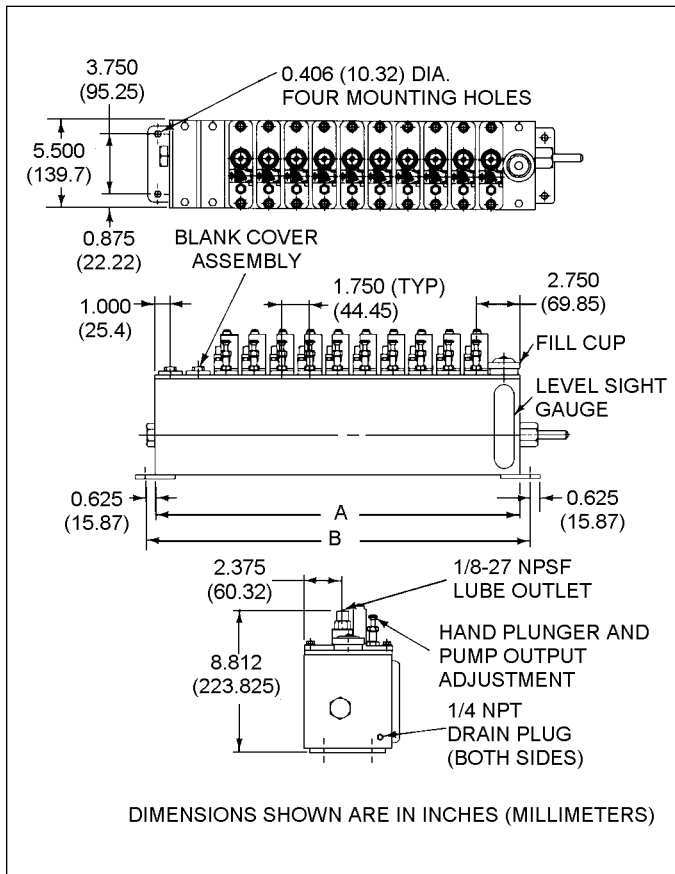

Option	Size		Dimensions - in (mm)			
	pt	liters	A		B	
T1	4	1.89	5.50	(139.70)	6.75	(171.45)
T2	6	2.84	7.25	(184.15)	8.50	(215.90)
T3	8	3.79	10.75	(273.05)	12.00	(304.80)
T4	12	5.68	16.00	(406.40)	17.25	(438.15)
T5	16	7.57	23.00	(584.20)	24.25	(615.95)
T6	24	11.36	30.00	(762.00)	31.25	(793.75)
T7	32	15.14	37.00	(939.80)	38.25	(971.55)
T8	40	18.93	44.00	(1117.60)	45.25	(1149.35)

Note: A black cover assembly will be provided for all unused pump stations.

ORDERING INFORMATION

Replacement reservoirs are available only with drives. Order reservoir and drive option from menu. Omit all other options when ordering.

PUMPS

DESCRIPTION

Force Feed Box Lubricators are heavy-duty precision metering pumps capable of accurately pumping small flows of either mineral or synthetic oil to machinery injection points. The single-piston pump is mechanically driven from a common camshaft in the reservoir and are adjustable from 1 to 27 drops per stroke. The drive options, shown on page 8 thru 10, provide many more variations to suit the application. Model 76/88 Pumps are interchangeable with competitive models. The pump's maximum pressure is variable up to 7,500 psi depending on the piston size. All working parts are totally enclosed away from dirt, water, and impurities and self-lubricated at all times by the fluid in the reservoir.

Model 76/88 Pumps are rugged, heavy duty units. The pump cylinder housing is a precision machined casting fitted with an alloy steel piston.

The pump is actuated by a hardened steel roller following a cam for low torque and longer life. The visual sight is one-piece injection molded material that is impervious to ultra-violet rays, and mineral and synthetic oils.

Three piston sizes are available to produce outputs up to 27 drops per stroke.

FEATURES/BENEFITS

- Rugged construction for high performance and durability
- Easy serviceability - pumps can be added or replaced quickly
- Pump output is easily adjustable

OPERATION

Pumps With Sight Glass

Rotation of the lubricator cam actuates the pump rocker arm assembly to operate the pump piston. On the piston down-stroke, spring pressure is exerted on the piston causing it to follow the cam. As it moves down, a pressure reduction is created between the piston and the check valve and the valve closes. The supply inlet shut-off ball is then unseated and lubricant is drawn into the piston cylinder from the sight well. This creates a pressure reduction (vacuum) in the air-tight sight well that causes lubricant from the reservoir to be drawn into the well until pressure is equalized. On the piston up-stroke, the oil in the cylinder is injected out through the discharge check valve to the machine injection point.

The number of drops seen falling in the sight well is the amount of oil discharged by the pump. Each pump can be adjusted by means of an external screw. This changes the length of the pump stroke which changes the pump discharge volume.

Pumps With Pressurized Supplies

Rotation of the lubricator cam actuates the pump rocker arm assembly to operate the pump piston. On the piston down-stroke, spring pressure is exerted on the piston causing it to follow the cam. As it moves down, a pressure reduction (vacuum) is created between the piston and the discharge check valve and the valve closes. This allows the pressurized supply to unseat the supply inlet shut-off ball and pressurize the piston bore with lubricant. On the piston up-stroke, the piston forces the supply inlet shut-off ball to seat and shut off the pressurized supply. Lubricant in the piston cylinder is forced out through the discharge check valve to the machine injection point. Each pump can be adjusted by means of an external screw. This changes the length of the pump stroke which changes the pump discharge volume.

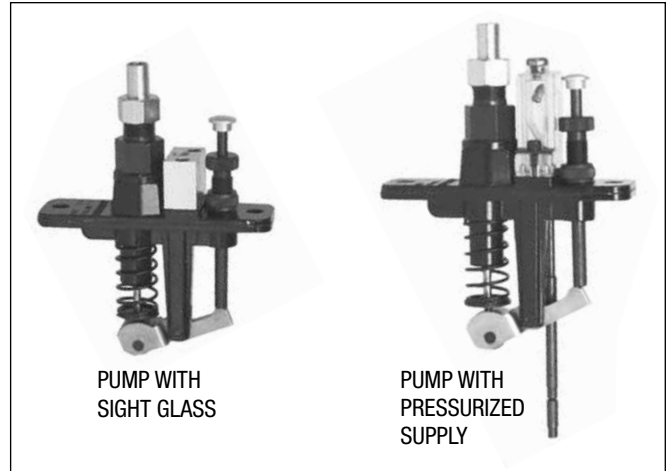

Model 88 Pumps

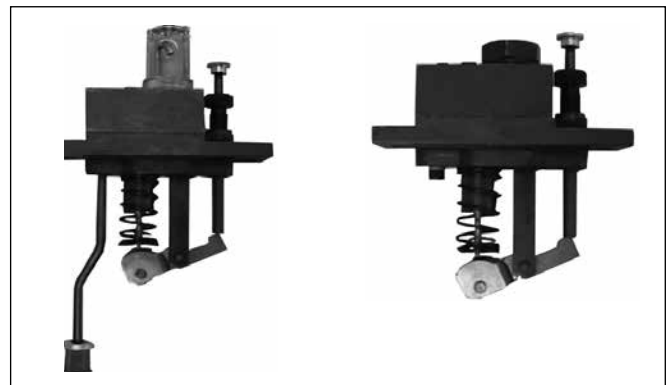

Model 76 Pumps

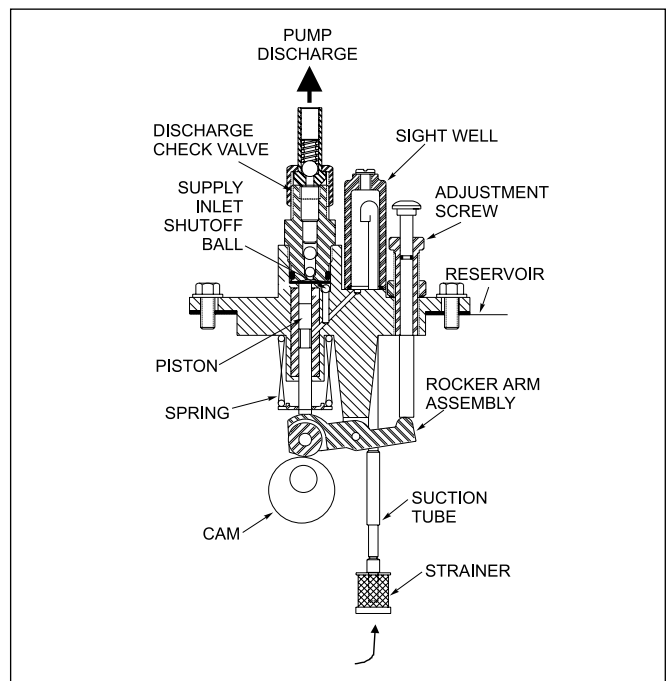

Pumps With Sight Glass

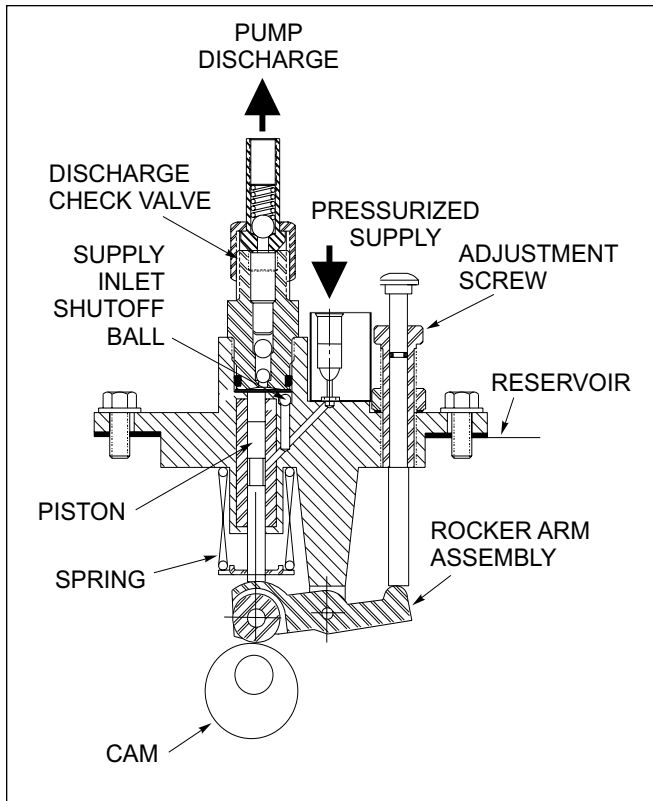

Pumps With Pressurized Supplies

ADJUSTMENT

Pump discharge (output flow) can be adjusted within the min./ max. ranges as shown in the illustration. The adjustment is linear. Therefore, positioning the screw midway will produce one-half of the pump capacity. To adjust the flow, proceed as follows:

1. Loosen adjusting screw locknut.
2. Turn the adjusting screw to the desired position and, with the pump operating, count the drops falling in the sight well for a one-minute interval.
3. Tighten adjusting screw locknut.

Calculate Pints Per Day As Follows:

$$\frac{\text{Number of Drops/Min.} \times 1440 \text{ (Minutes in a Day)}}{14115 \text{ (Number of drops in a Pint)}} = \text{Pints/Day}$$

Calculate Minimum or Maximum Pump Output Capacity

$\frac{\text{Input Speed} \times \text{Gear Ratio}}$	\times	$\frac{\text{Pump Output (Min. or Max. drops/stroke)}}{1440 \text{ (Min./day)}}$	\times	14115	$=$	Min. or Max. Pump Output (Pints Per Day)
1725		12		1440		
300:1		per stroke		(Number of Drops in a Pint)		

* Minimum and Maximum Drops Per Stroke Listed in Specifications on the next page.

NOTE: For proper sizing select the appropriate Lubricator brand. Brand as well as piston size will effect minimum and maximum pump capacity.

The following example is a Manzel lubricator, electric motor driven, 300:1 internal ratio, 1/4" pump model 76/88. Solve for maximum flow:

$\frac{1725 \text{ Motor Speed} \times \text{Max. 12 drops}}{300:1 \text{ Gear Ratio}}$	\times	$\frac{1440 \text{ Min.}}{\text{per stroke}}$	$=$	Max. 7.04 Pints/day
14115		(Number of Drops in a Pint)		

To Calculate Minimum: Replace the maximum 12 drops per stroke with the minimum 2 drops per stroke: (1.17 minimum pints per day)

ORDERING INFORMATION

Use the following part numbers if you are ordering only a pump assembly and a Modular Box Lubricator. Blank cover assemblies may be ordered by specifying part number **No Graco Part Number (471-690-054)**.

Pump Specifications										
Ordering Code	Piston Size (in)	Max Pressure (psi)	*Drops per Stroke		cu.in. per Stroke		cu.cm. per Stroke		Strokes per Minute	
			Max	Min	Max	Min	Max	Min	Max	Min
76/88B	3/16	7500	6	1	0.013	0.002	0.213	0.033	50	3
76/88C	1/4	6000	12	2	0.024	0.004	0.393	0.066	50	3
76/88E	3/8	2500	27	4	0.055	0.008	0.901	0.131	50	3

*When approaching maximum outputs some oils will stream rather than form drops in sight glass.

1. Based on 500 SUS oil at 70°F ambient. Heavier oil will product fewer but larger drops
2. When approaching maximum outputs, some oils will stream rather than form drops in sight glass
3. For operating pressures over 50% of the rated maximum, consult the factory

Description	Part Numbers			
	Standard Pump	Old Standard Pump	Pressurized Pump	Old Pressurized Pump
76B - 3/16 in Pump	562953	376-000-000	562961	376-000-120
76C - 1/4 in Pump	562955	376-000-010	562963	376-000-130
76E - 3/8 in Pump	562957	376-000-030	562965	376-000-150
88B - 3/16 in Pump	562954	376-000-001	562962	376-000-121
88C - 1/4 in Pump	562956	376-000-011	562964	376-000-131
88E - 3/8 in Pump	562958	376-000-031	562966	376-000-151

PUMP SIGHT GLASS REPAIR KITS

Sight Glass Repair Kits are available for both the Manzel Model 76 & 88 Pumps. Sight Glass Kits are independent of pump sizes

Description	Part Numbers	
	Sight Glass Kit	Old Sight Glass Kit
Model 76	563967	562-000-200
Model 88	564437	560-001-860

DRIVES/MOTORS

DESCRIPTION

Six drive configurations, some with several variations, provide a total of 18 options. These configurations are listed below in conjunction with pertinent technical data and a detailed dimensional drawing. All options are available as left- or right-hand.

DIRECT END ROTARY – OPTION G01

This option is shown in the right-hand location. It is not available with the motor option.

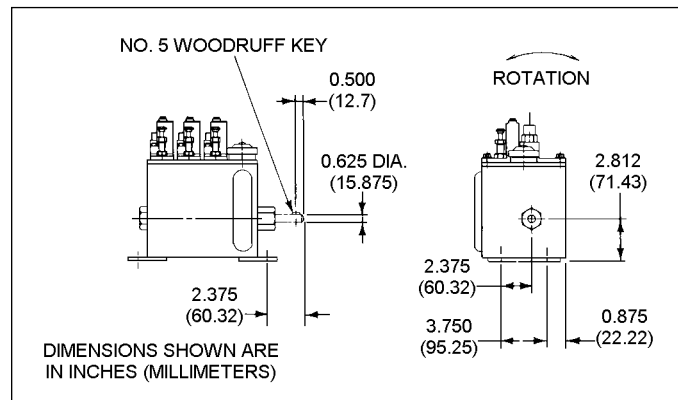

OPTION G01

END RATCHET – OPTION G02

Option G02 is shown in the right-hand location. It is not available with the motor option. The drive arm is not included with this option. If desired, specify part number **563005 (453-004-603)**.

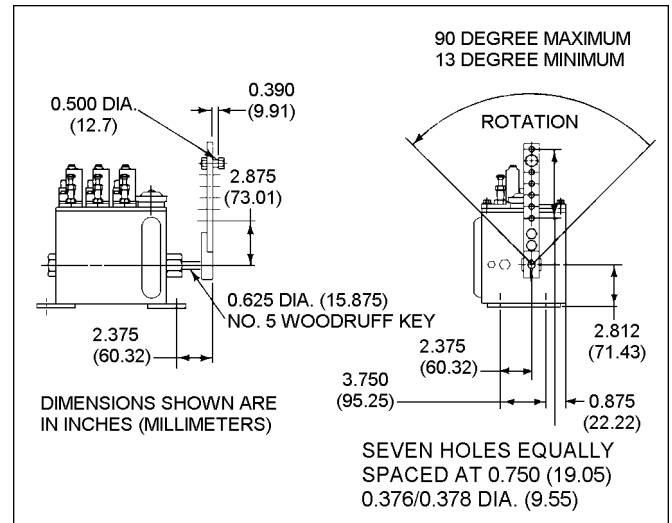

END ROTARY RATCHET – OPTIONS G03 AND G04

Option G03 as a right-hand drive is shown. It is not available with the motor option. Specifications are as follows:

Option	Ratio	Max Input Speed
G03	37.5:1	800 rpm
G04	75:1	800 rpm

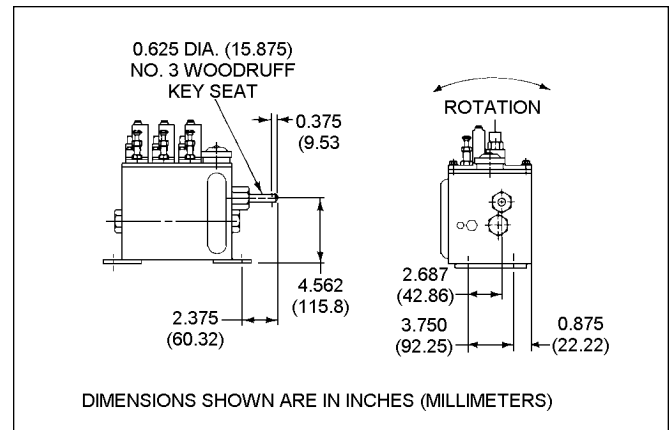

DOUBLE REDUCTION END ROTARY – OPTIONS G05 THROUGH G09

These drive options are available in either left- or right-hand configurations: the right-hand is shown. When the motor option is selected, it is available only for a right-hand drive. It is available in five ratios as follows:

Descriptor	Part No.	Old Part No.
G05 - 25:1	564055	481-760-012
G06 - 50:1	564054	481-760-009
G07 - 100:1	563121	481-760-010
G08 - 200:1	563122	481-760-011
G09 - 400:1	563120	481-760-004

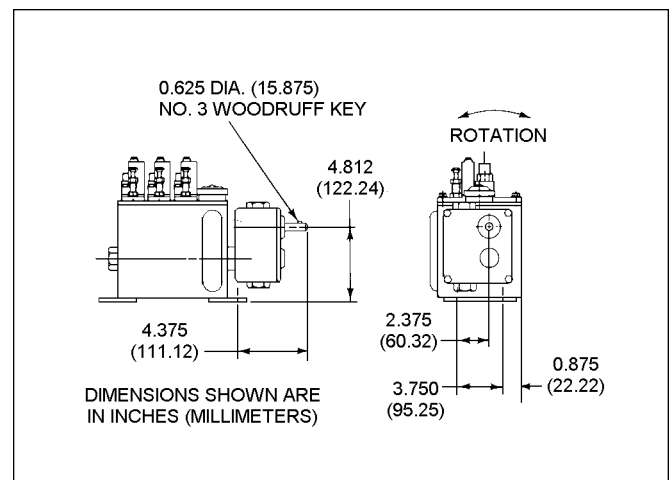

RIGHT ANGLE ROTARY DRIVE – OPTIONS G10 THROUGH G13

These drive options are available for right-hand and left hand drives only. This option is not available with the motor option. Ratios for each drive option are listed below:

NOTE: Top, bottom and front drive locations are available on request as special orders.

Option	Ratio
G10	25:1
G11	50:1
G12	188:1
G13	375:1

GEAR REDUCER – OPTIONS G14 THROUGH G18

These options are shown below and the ratios and part numbers for each option are as follows:

Option	Ratio
G14	100:1
G15	150:1
G16	200:1
G17	300:1
G18	400:1

DRIVE LOCATIONS

All drives may be ordered for either right- or left-hand locations, except for Options G05 through G09, when ordered with one of the motor options. When other drive locations are needed, contact Graco or one of its Manzel distributor locations.

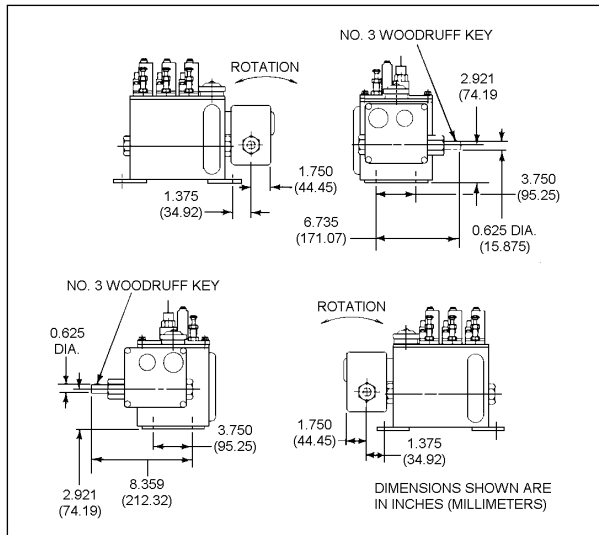

OPTION G10 - G13

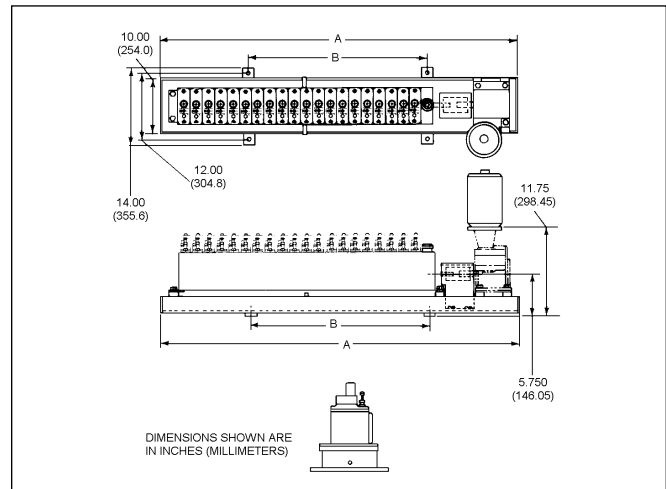

OPTION G14 - G18

MOTORS

Ten motor options are available to meet the following requirements: Other motors may be supplied as specials to meet duty conditions not listed (contact factory).

Power	Voltage	Horse Phase	Type	Duty No.	Part No.	Old Part No.
M2	1/4	115/230	1	See A	558289	492-440-190
M3	1/4	115/230	1	See B	558293	492-600-090
M5	1/4	230/460	3	See A	558290	492-440-360
M6	1/2	230/460	3	See B	558292	492-600-020
M7	1/2	115/230	1	See C	558294	492-620-060
M8	1/2	230/460	3	See C	558295	492-620-070
M9	1/4	115/230	1	See B	558293	492-600-090
M10	1/2	230/460	3	See B	558291	492-540-310
M11	1/2	115/230	1	See D	557271	492-380-040
M12	1/2	230/460	3	See D	557270	492-380-030

Note: All motors operate at 1725 rpm. M2, M3, M5, M6 are foot-mounted (56F). M7, M8 are foot-mounted (56F) for T1-T5, face-mounted (56C) for T6-T8. M9-M12 are face-mounted (56C)

Duty-Type: A) Totally-enclosed, non-ventilated (TENV); B) Hazardous Area, Class 1, Group D; C) Hazardous Area, severe duty, Class 1, Group C, tropical insulation; D) Totally-enclosed, fan-cooled (TEFC)

MOTOR MOUNTING BASES – OPTIONS P1 THROUGH P5

A motor mounting base option is available for all standard size reservoirs (Options T1 through T5). These options may be used only with drive options G06 through G09. Dimensional data for the bases is provided below:

Option	Reservoir Capacity	Dimensions in (mm)			No. of Mounting Holes
		A	B	C	
P1	T1 - 4 pt (1.89 liter)	24.50 (622.30)	20.50 (520.70)	–	4
P2	T2 - 6 pt (2.84 liter)	26.25 (666.75)	22.25 (565.15)	–	4
P3	T3 - 8 pt (3.79 liter)	29.75 (755.65)	25.76 (654.05)	–	4
P4	T4 - 2 pt (5.68 liter)	35.00 (889.00)	15.50 (393.70)	15.50 (393.70)	6
P5	T5 - 6 pt (7.51 liter)	42.00 (1066.80)	19.00 (482.60)	19.00 (482.60)	6

MOTOR MOUNTING BASES – OPTIONS P6, P7, AND P8

A motor mounting base option is available for all standard size reservoirs (Options T6, T7, and T8). These options may be used only with drive options G14 through G18. Dimensional data for the bases is shown below:

Option	Reservoir Capacity	Dimensions in (mm)		No. of Mounting Holes
		A	B	
P6	T6 - 24 pt (11.36 liter)	46.00 (1168.40)	16.00 (406.40)	4
P7	T7 - 32 pt (15.14 liter)	53.00 (1346.20)	23.00 (584.20)	4
P8	T8 - 40 pt (18.93 liter)	60.00 (1524.00)	30.00 (762.00)	4

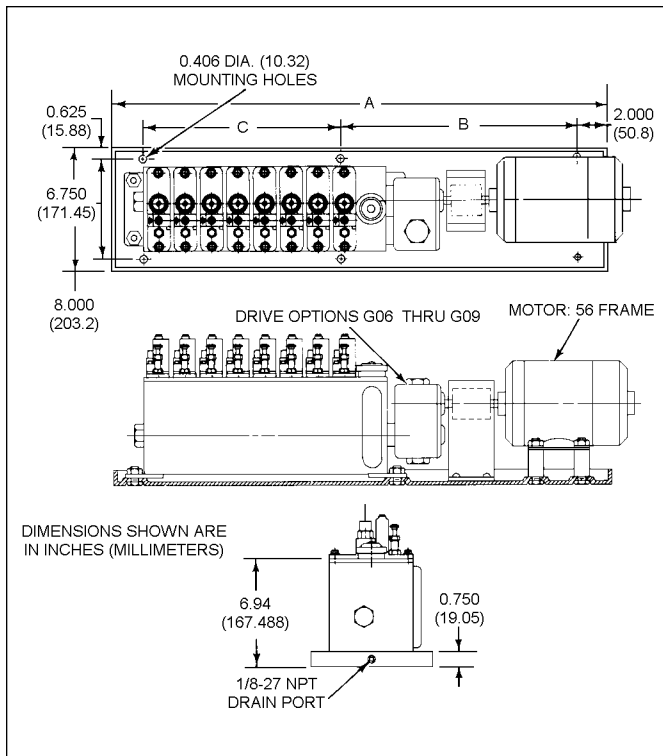

OPTION P1 - P5

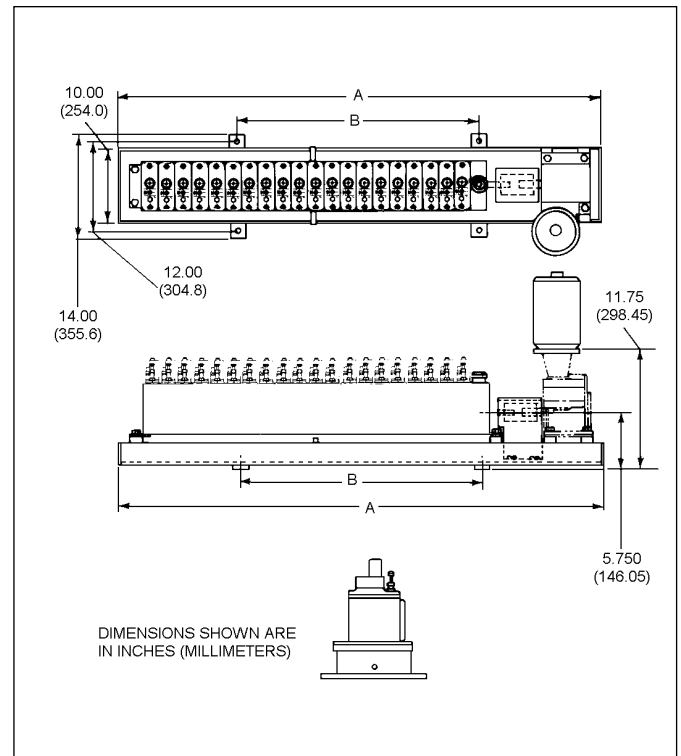

OPTION P6 - P8

ACCESSORIES

AUTOMATIC FILL – OPTIONS F1, F2, F3, AND F4

OPTION F1 – Gravity Supply

This option is mounted in the last pump station at the end opposite the drive. The only exception is when either a shaft rotation alarm or one of the low level options is specified. Then this option is mounted in the second to the last pump station. Pertinent dimensional data is provided in the following illustration. Specify part number **559037 (456-030-031)** when ordering this option separately.

NOTE: An inlet oil pressure head of 2 to 5 feet is required for the gravity supply.

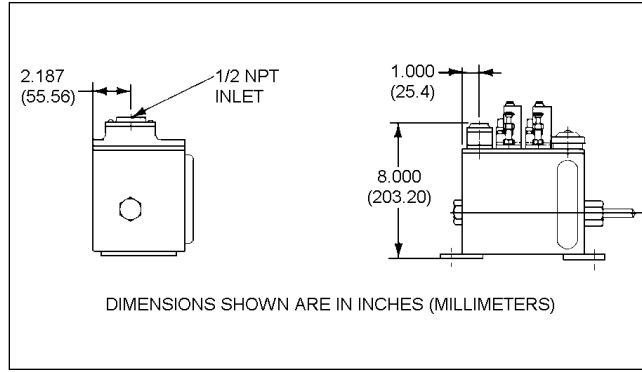

OPTION F1

OPTION F2 – Pressurized Supply

This option is mounted in the last pump station at the end opposite the drive. The only exception is when either a shaft rotation alarm or one of the low level options is specified. Then this option is mounted in the second to the last pump station. Pertinent dimensional data is provided in the following illustration. The inlet pressure should be between 15 and 70 psig. Specify part number **563026 (456-030-035)** when ordering this option separately.

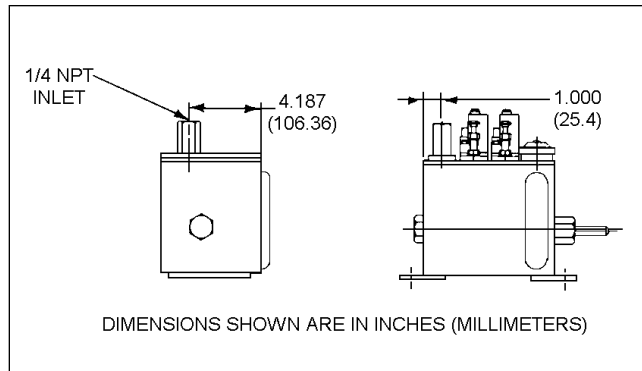

OPTION F2

OPTION F3 – Oil Level Controller

This automatic fill option does not require a pump station for mounting. It is mounted only on the front of the reservoir and requires a maximum inlet pressure of 5 psi. Specify part number **No Graco Part No. (456-030-032)** when ordering this option separately.

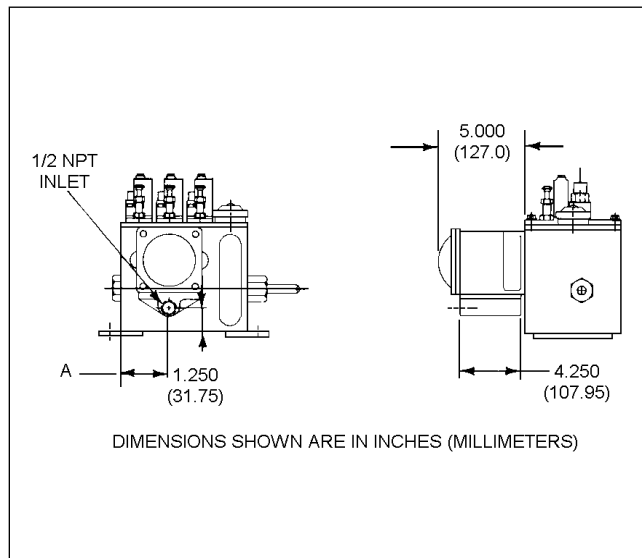

OPTION F3

Option	Reservoir		Dimension A	
	pt	liters	in	mm
T1	4	1.89	1.00	25.40
T2	6	2.84	2.75	69.85
T3	8	3.79	3.63	92.08
T4	12	5.68	3.63	92.08
T5	16	7.57	11.50	292.10
T6	24	11.36	15.00	381.00
T7	32	15.14	12.38	314.33
T8	40	18.93	14.13	358.78

OPTION F4 – Pressurized Supply With Level Control

This automatic fill option mounts on the front of the reservoir and requires a 0 to 70 psi inlet supply. The switch actuates when a 1/2 to 3/4 loss of oil level occurs in the controller.

ELECTRICAL DATA:

Contacts: Single-Pole, Double-Throw

Contact Rating: 15 amps at 115/230 or 480 VAC

0.5 amps at 125 VDC

0.25 amps at 250 VDC

Switch Rating: Class 1, Groups C and D, Division I

Option	Reservoir		Dimension A	
	pt	liters	in	mm
T1	4	1.89	1.00	25.40
T2	6	2.84	2.75	69.85
T3	8	3.79	3.63	92.08
T4	12	5.68	3.63	92.08
T5	16	7.57	11.50	292.10
T6	24	11.36	15.00	381.00
T7	32	15.14	12.38	314.33
T8	40	18.93	14.13	358.78

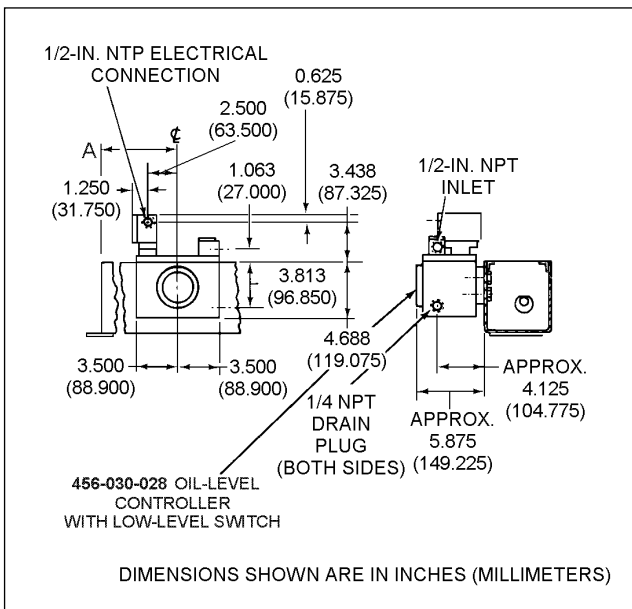

OPTION F4

LOW LEVEL SWITCH — OPTION 5 (L1 & L2)
Option L1 - Class 1, Group C&D

The low level switch is single-pole, double-throw and meets the explosion-proof requirements of Class 1, Groups C and D, as well as Class 2, Groups E, F, and G. This option is mounted in the last pump station opposite the drive end. The only exception is when a shaft rotation alarm option is specified, then it is mounted in the third to the last pump station. Dimensional data and electrical ratings are shown on the following illustration.

Specify part number **563013 (456-010-164)** when ordering this option separately.

Electrical Data: 15 amps at 115/230 or 480 VAC

0.5 amps at 125 VDC

0.25 amps at 250 VDC

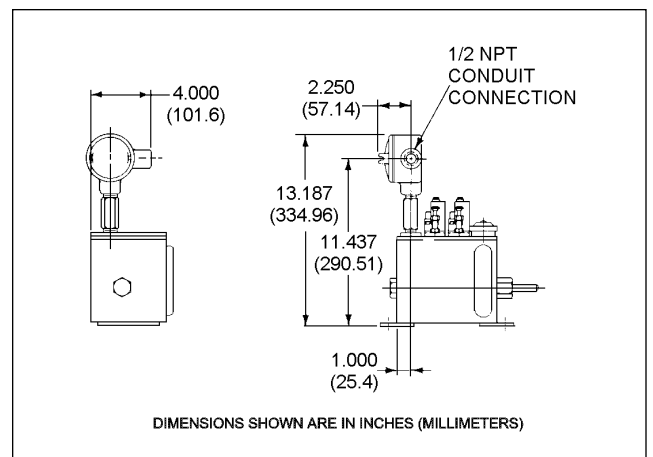

OPTION L1

OPTION L2

The low level switch is single pole-single throw, N.C. Electrical rating is 10 watts @120 VAC (Minimum). This option is mounted in the last pump station opposite the drive end. The only exception is when a shaft rotation alarm option is specified, then it is mounted in the third to the last pump station. Dimensional data and electrical ratings are shown on the following illustration.

Specify part number **564015 (456-010-190)** when ordering this option separately.

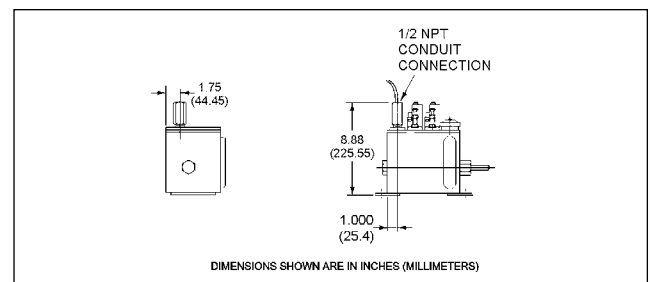

OPTION L2

SHAFT ROTATION ALARM – OPTIONS S1, S2, S3

The shaft rotation alarm meets the explosion-proof requirements of Class 1, Groups B, C, and D, as well as Class 2, Groups E, F and G. It is always mounted in the last pump station at the end of the reservoir opposite the drive. Option S1 is an alarm without a switch. Options S2 and S3, are single-pole, double-throw and double-pole, double-throw, switches respectively. These switches are factory set to signal when the pressure falls below 50 psig (3.515 kg/cm²). Pressure switch operation is dependent on shaft rotation and adequate oil level to maintain switch setting. Dimensional data and electrical ratings are provided in the illustration shown below.

ELECTRICAL RATINGS: 15 amps at 125/250 VAC
 1/2 amp at 125 VDC
 1/4 amp at 250 VDC

Option	Part No.	Old Part No.
S1	562947	301-300-039
S2	563021	456-020-459
S3	564016	456-020-460

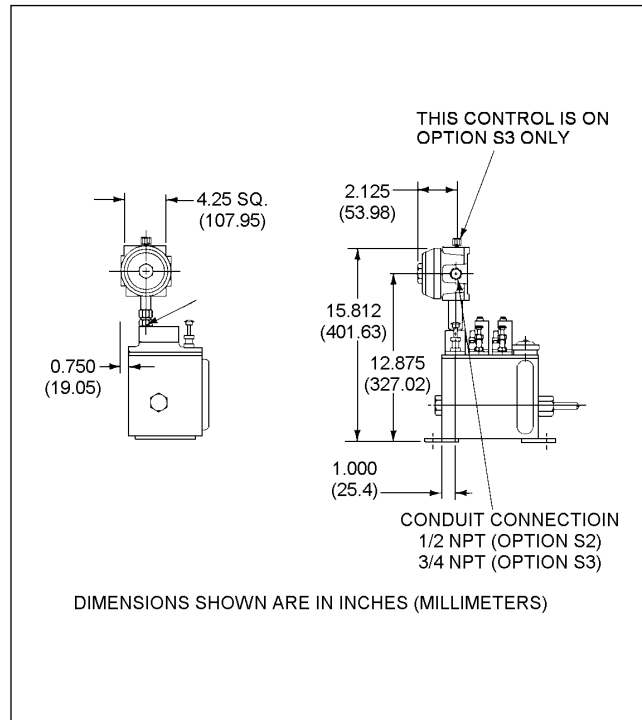

ELECTRIC HEATER – OPTIONS H1 THROUGH H6

Electric heater options are not available for the four-pint reservoir (Option T1). Heater options H2 and H4 require two heaters. Heater options H5 and H6 require three heaters. Specifications for these heaters are provided in the following tables and the dimensional data is shown in the illustrations.

CAUTION: Heater elements must be completely submerged in oil at all times.

Specifications	
Heater Options H1, H2 and H5	
Voltage	115 volts
Wattage	150 watts
Thermostat Voltage	115/230 volts
Temperature Range	-100°F to 500°F (38°C to 260°C)
Watt Density	20 w/sq.in.
Hazardous Area Rating Compatibility	Class 1, Group D
Part No. (Old)	564058 (492-041-721)
Heater Options H3, H4 and H6	
Voltage	12 volts
Wattage	200 watts
Thermostat Voltage	120 volts
Temperature Range	60°F to 240°F (15.6°C to 116°C)
Watt Density	22 w/sq.in.
Hazardous Area Rating Compatibility	Class 1, Group B
Part No. (Old)	557207 (492-041-734)

Reservoir Capacity	Dimensions – in (mm)								Option
	Options H1, H2 and H5				Options H3, H4 and H6				
	A	B	C	D	E	F	G	H	
T2 - 6 pt (2.84 liter)	4.75 (120.65)	3.625 (92.08)	-	-	4.50 (114.30)	1.875 (47.625)	-	-	H1 or H3
T3 - 8 pt (3.79 liter)	4.125 (104.78)	4.50* (114.30)	-	-	4.50 (114.30)	5.375 (136.53)	-	-	H1 or H3
T4 - 12 pt (5.68 liter)	4.125 (104.78)	9.75 (247.65)	-	-	4.50 (114.30)	5.375 (136.53)	-	-	H1 or H3
T5 - 16 pt (7.57 liter)	4.125 (104.78)	6.25 (158.75)	10.50 (266.70)	-	4.50 (114.30)	7.125 (180.98)	8.75 (222.25)	-	H2 or H4
T6 - 24 pt (11.36 liter)	4.125 (104.78)	8.00 (203.20)	14.00 (355.60)	-	4.50 (114.30)	8.875 (225.43)	12.25 (311.15)	-	H2 or H4
T7 - 32 pt (15.14 liter)	4.125 (104.78)	6.25 (158.75)	12.25 (311.15)	12.25 (311.15)	4.50 (114.30)	7.125 (180.98)	10.50 (266.70)	12.25 (311.15)	H5 or H6
T8 - 40 pt (18.93 liter)	4.125 (104.78)	6.25 (158.75)	10.50 (266.70)	10.50 (266.70)	4.50 (114.30)	7.125 (180.98)	15.75 (400.05)	14.00 (355.60)	H5 or H6

*For right-hand drive. For left-hand drive, dimension B = 6.25 (158.75)

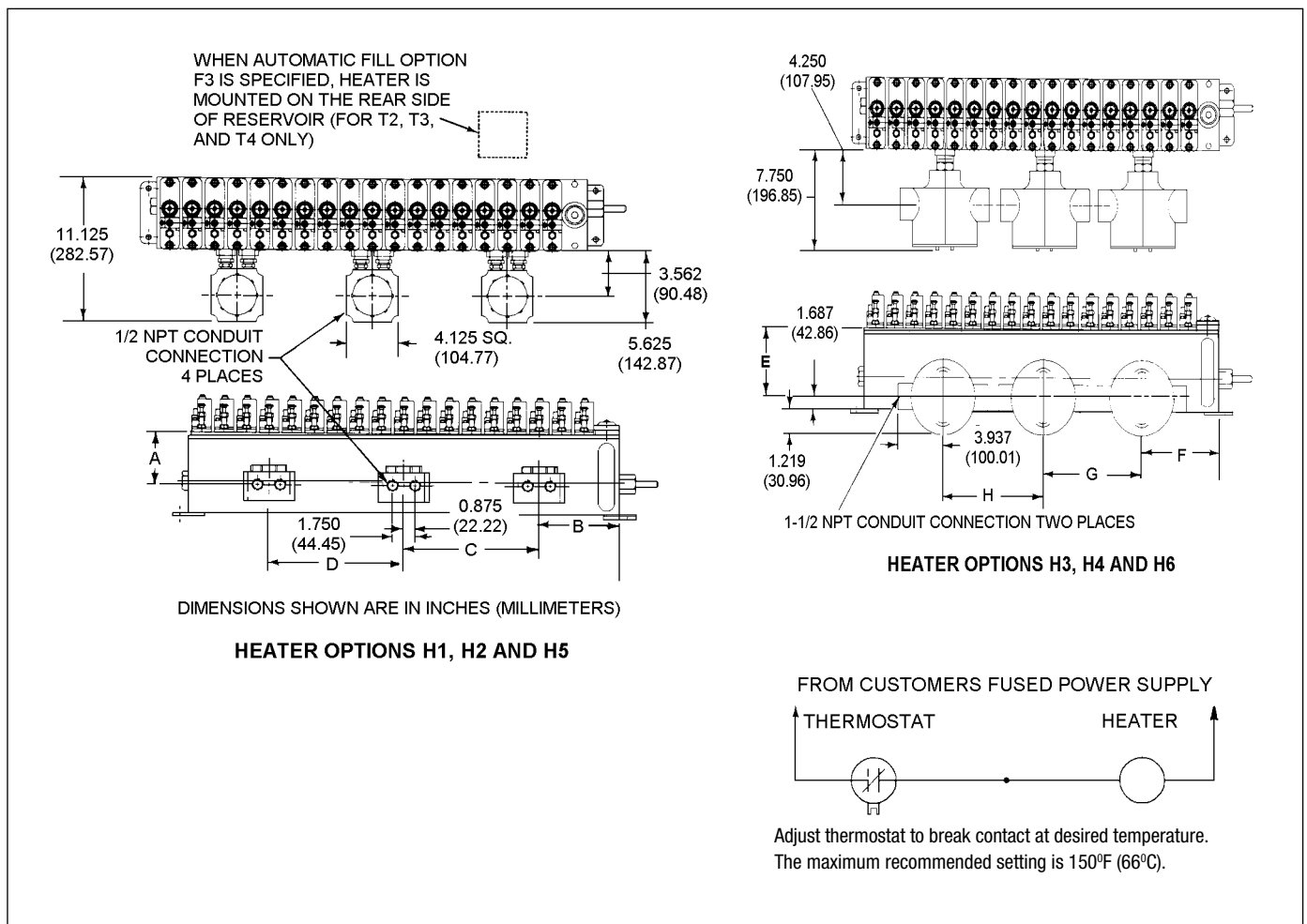

WIRING SCHEMATIC FOR HEATER OPTIONS

MBL XX - XXX - XX - XXX - X - XX - XX - XX - XX - XX - XX - XX

Reservoir Size

T1 - 4 pt, 2 pump stations max	T5 - 16 pt, 12 pump stations max
T2 - 6 pt, 3 pump stations max	T6 - 24 pt, 16 pump stations max
T3 - 8 pt, 5 pump stations max	T7 - 32 pt, 20 pump stations max
T4 - 12 pt, 8 pump stations max	T8 - 40 pt, 24 pump stations max

***Pump Size**

76/88b - 3/16 in Model 76 & 88 Pump	76/88e - 3/8 in Model 76 & 88 Pump
76/88c - 1/4 in Model 76 & 88 Pump	

***Pump Quantity**

01 - 1 Pump	06 - 6 Pumps	11 - 11 Pumps	16 - 16 Pumps	21 - 21 Pumps
02 - 2 Pumps	07 - 7 Pumps	12 - 12 Pumps	17 - 17 Pumps	22 - 22 Pumps
03 - 3 Pumps	08 - 8 Pumps	13 - 13 Pumps	18 - 18 Pumps	23 - 23 Pumps
04 - 4 Pumps	09 - 9 Pumps	14 - 14 Pumps	19 - 19 Pumps	24 - 24 Pumps
05 - 5 Pumps	10 - 10 Pumps	15 - 15 Pumps	20 - 20 Pumps	

Drive Options

G01 - Direct End Rotary	G07 - Double Reduction End Rotary 100:1	G13 - Right Angle Rotary 375:1
G02 - End Ratchet	G08 - Double Reduction End Rotary 200:1	G14 - 100:1 Gear Reducer
G03 - End Rotary Ratchet 37.5:1	G09 - Double Reduction End Rotary 400:1	G15 - 150:1 Gear Reducer
G04 - End Rotary Ratchet 75:1	G10 - Right Angle Rotary 25:1	G16 - 200:1 Gear Reducer
G05 - Double Reduction End Rotary 25:1	G11 - Right Angle Rotary 50:1	G17 - 300:1 Gear Reducer
G06 - Double Reductin End Rotary 50:1	G12 - Right Angle Rotary 188:1	G18 - 400:1 Gear Reducer

Drive Location

R - Right-Hand End of Reservoir L - Left-Hand End of Reservoir

***Motor Mounting Base**

P1 - For 4 pt Reservoir	P3 - For 8 pt Reservoir	P5 - For 16 pt Reservoir	P7 - For 32 pt Reservoir
P2 - For 6 pt Reservoir	P4 - For 12 pt Reservoir	P6 - For 24 pt Reservoir	P8 - For 40 pt Reservoir

***Motor Options**

- M2 - 1/4 Hp 1725 Rpm, 115/230 V,1 Ph., Tenv Motor, Foot-Mounted (56f)
- M3 - 1/4 Hp 1725 Rpm, 115/230 V,1 Ph., Hazardous Area , Class 1, Group D, Foot-Mounted (56f)
- M5 - 1/4 Hp 1725 Rpm, 230/460 V,3 Ph., Tenv Motor, Foot-Mounted (56f)
- M6 - 1/4 Hp 1725 Rpm, 230/460 V,3 Ph., Hazardous Area , Class 1, Group D, Foot-Mounted (56f)
- M7 - 1/2 Hp 1725 Rpm, 115/230 V,1 Ph., Hazardous Area , Class 1, Group C, Severe Duty, Tropical Insulation
- M8 - 1/2 Hp 1725 Rpm, 230/460 V,3 Ph., Hazardous Area , Class 1, Group C, Severe Duty, Tropical Insulation
- M9 - 1/4 Hp 1725 Rpm, 115/230 V,1 Ph., 60hz, Class 1, Group D, Face-Mounted (56c)
- M10 - 1/2 Hp 1725 Rpm, 230/460 V,3 Ph., 60hz, Class 1, Group D, Face-Mounted (56c)
- M11 - 1/2 Hp 1725 Rpm, 115/230 V,1 Ph., 60hz, Tefc, Face-Mounted (56c)
- M12 - 1/2 Hp 1725 Rpm, 230/460 V,3 Ph., 60hz, Tefc, Face-Mounted (56c)

***Automatic Fill Option**

F1 - Gravity Supply	F2 - Pressurized Supply	F3 - Oil Level Control	F4 - Pressurized Supply w/Level Control
---------------------	-------------------------	------------------------	---

***Low Level Options**

L1 - Low Level Switch Hazardous Area . C11, Group C&D, C12 Group E,F,G	L2 - Low Level, 10 Watts At 120 Vac, Spst Reed Switch, Nc
--	---

***Shaft Rotation and Low Level Alarm Options**

S1 - Alarm W/out Electrical Switch	S2 - Alarm W/Spdt Switch, Hazardous Area . C11, Group B,C,D, C12 Group E, F, G	S3 - Alarm W/Dpdt Switch, Hazardous Area . C11, Group B,C,D, C12 Group E, F, G
------------------------------------	--	--

***Heater Option**

H1 - Electric Heater, Hazardous Area , Class 1, Group D (4,6,8 And 12 Pint Reservoirs, 1 Heater)	H4 - Electric Heater, Hazardous Area , Class 1, Group B (16 And 24 Pint Reservoirs, 2 Heaters)
H2 - Electric Heater, Hazardous Area . Class 1, Group D (16 And 24 Pint Reservoir, 2 Heaters)	H5 - Electric Heater, Hazardous Area , Class 1, Group D (32 And 40 Pint Reservoirs, 3 Heaters)
H3 - Electric Heater, Hazardous Area , Class 1, Group B (4,6, 8 And 12 Pint Reservoirs, 1 Heater)	H6 - Electric Heater, Hazardous Area , Class 1, Group B (32 And 40 Pint Reservoirs, 3 Heaters)

*Omit if not required

Notes:

1. When pump quantity is less than max pump stations of specified reservoir, blank cover assembly; part no. No Graco Part No. (471-609-054) is placed in the unused pump stations.
2. When shaft rotation alarm, low level or automatic fill (F1 or F2) options are specified, deduct one pump station for each option.
3. Require mounting base options P6, P7 and P8
4. May be used only with options G06 through G09 when drive option is specified
5. M7 and M8 are foot-mounted (56F) for T1 through T5 and face-mounted (56C) for T6 through T8
6. Used only for drive options G14 through G18

Contact us today!

To receive product information or talk with a Graco representative, call 800-533-9655 or visit us online at www.graco.com.

