



First choice when  
quality counts.™

# Oil King™

## 25 Gallon (94.6 Liter) Oil Receiver

**A convenient,  
practical  
used-oil  
receiver –  
tough enough  
to handle the  
rigors of a  
busy shop**

### Typical Fluids Handled

- Motor oil
- Automatic transmission fluid
- Gear oil
- Hydraulic oil
- Power steering fluids
- Engine coolants

### Typical Industry Applications

- Automotive dealerships
- Automotive specialty repair shops
- Light and medium duty vehicle fleet service shops
- Municipal service garages
- General service and repair garages



The Oil King receiver is designed with the busy shop in mind. Many features make this 25 gallon (94.6 liter) capacity receiver easy to maneuver around the worksite – from the oversized tires that move smoothly across uneven flooring and over hoses, to the push-pull handles around the top perimeter. The large funnel can collect fluids from both a drain plug and a filter port at the same time. This funnel can be raised to a maximum height of 72 in. (183 cm) and is equipped with a filter screen to prevent debris from entering the tank.

A full-length liquid level sight gauge lets you know when the tank is full. To empty the tank, choose the method that works best in your shop: gravity drain from a bottom valve or suction-evacuate from the top. To help keep your tools at your fingertips, the Oil King features convenient, built-in holding bins for new or used filters, wrenches and rags. The bins allow used filters to drain completely right into the tank, without cluttering the funnel. Made from a heavy-duty, durable UV-stabilized polymer, this used-oil receiver is dent-, rust- and corrosion-resistant and never needs painting to maintain its original appearance.

## Technical Specifications

<b>Length</b> .....	24 in. (610 mm)
<b>Width</b> .....	24 in. (610 mm)
<b>Height</b>	
<b>with bowl at lowest adjustment</b>	3-3/4 ft. (1143 mm)
<b>with bowl at highest adjustment</b>	6 ft. (1829 mm)
<b>Dry weight</b> .....	54 lbs. (24.5 kg)
<b>Collection bowl size</b> .....	22 x 24 in. (508 x 559 mm)
<b>Inspection port size</b> .....	3 in. (76 mm) thread
<b>Fluid outlet fitting size</b> .....	3/4 in. port
<b>Operating temperature range</b> ...	30-120°F (1.11-49°C)
<b>Maximum oil temperature</b> .....	220°F (104°C)
<b>Semi-pneumatic wheel</b> .....	10 in. (254 mm)
<b>Urethane casters</b> .....	3 in. (76 mm)
<b>Filter drain compartment capacity</b> .....	6 filters
<b>Color</b> .....	black, white logo, red casters
<b>Wetted parts</b> .....	linear low-density polyethylene (LLDPE), zinc-plated steel, brass, nylon, polypropylene, PVC
<b>Instruction manual</b> .....	308-667

## Ordering Information

**238866 Oil King Oil Receiver**

### Oil-Pumping Systems

#### **224873 Wall-mount 716 diaphragm pump system**

**Includes:** **241906** 716 Diaphragm pump  
**240684** Air installation kit  
**240685** Fluid installation kit  
**224835** Wall bracket kit  
**240832** Drum-style adapter kit

#### **222090 Wall-mount 1040 diaphragm pump system**

**Includes:** **236265** 1040 Diaphragm pump  
**240684** Air installation kit  
**240685** Fluid installation kit  
**189233** Wall bracket accessory kit  
**240832** Drum-style adapter kit

## Dimensions

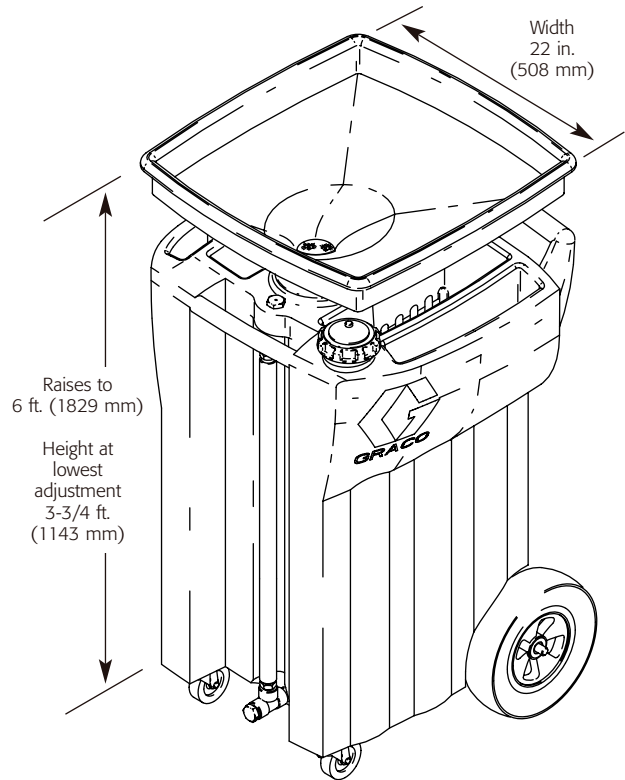

All written and visual data contained in this document are based on the latest product information available at the time of publication. Graco reserves the right to make changes at any time without notice.

## Sales/Distribution

North America Toll Free 800-533-9655

Telephone 612-623-6928

Fax 800-533-9656

[www.graco.com](http://www.graco.com)

Locate authorized distributors

Product information literature



GRACO INC.  
P.O. Box 1441  
Minneapolis, MN 55440-1441

Graco Inc. is registered to I.S. EN ISO 9001

