

Instructions – Parts List



3/4 HP (550 W) MOTOR, 55-GALLON DRUM SIZE

Air-Driven Agitators

306459N

100 psi (7 bar, 0.7 MPa) Maximum Working Pressure



Important Safety Instructions

Read all warnings and instructions in this manual.
Save these instructions.

See page 2 for Table of Contents.

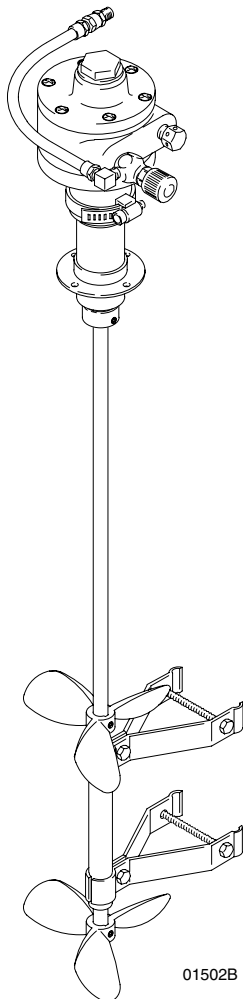

Model 203711
Drum agitator without
mounting tube

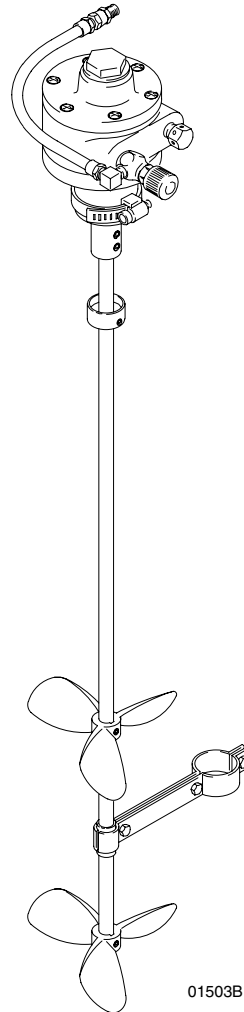

Model 204995
Drum agitator without
mounting tube

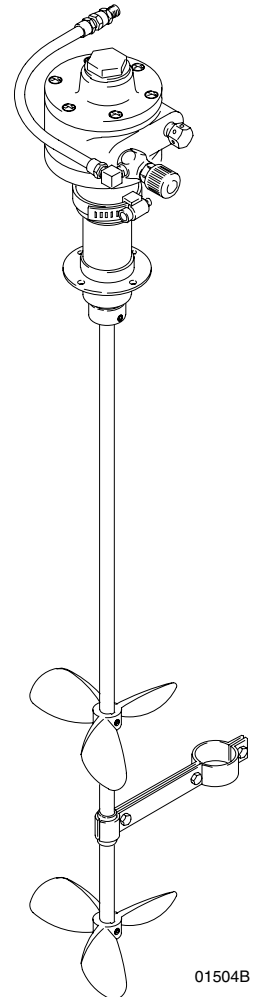

Model 206219
Drum agitator with
mounting tube

Table of Contents

Warnings	2
Installation	
Air Requirements	5
Air Line Accessories	5
Installing the Agitator on the Drum	5
Grounding	5
Operation	
Finding the Proper Agitator Speed	6
Operating the Agitator	6
Service	
Flushing the Air Motor	7
Servicing	7
Parts	
Model 203711	8
Model 204995	9
Model 206219	10
Technical Data	11
Warranty	12
Graco Information	12

Symbols

Warning Symbol



This symbol alerts you to the possibility of serious injury or death if you do not follow the instructions.

Caution Symbol



This symbol alerts you to the possibility of damage to or destruction of equipment if you do not follow the instructions.

! WARNING



INSTRUCTIONS

EQUIPMENT MISUSE HAZARD

Equipment misuse can cause the equipment to rupture or malfunction and result in serious injury.

- This equipment is for professional use only.
- Read all instruction manuals, tags, and labels before operating the equipment.
- Use the equipment only for its intended purpose. If you are not sure, call your Graco Distributor.
- Do not alter or modify this equipment. Use only genuine Graco parts and accessories.
- Check equipment daily. Repair or replace worn or damaged parts immediately.
- Do not exceed the maximum working pressure of the lowest rated component in your system. This equipment has a **100 psi (7 bar, 0.7 MPa) maximum working pressure**.
- Use fluids and solvents which are compatible with the equipment wetted parts. Refer to the **Technical Data** section of all equipment manuals. Read the fluid and solvent manufacturer's warnings.
- Always wear protective eyewear, gloves, clothing, and respirator as recommended by the fluid and solvent manufacturer.
- Comply with all applicable local, state, and national fire, electrical, and safety regulations.

WARNING



FIRE AND EXPLOSION HAZARD

Improper grounding, poor ventilation, open flames, or sparks can cause a hazardous condition and result in a fire or explosion and serious injury.

- Ground the equipment and the object being sprayed. Refer to **Grounding** on page 5.
- If there is any static sparking or you feel an electric shock while using this equipment, **stop spraying immediately**. Do not use the equipment until you identify and correct the problem.
- Do not use 1,1,1-trichloroethane, methylene chloride, other halogenated hydrocarbon solvents, or fluids containing such solvents in aluminum pumps. Such use could result in a serious chemical reaction, with the possibility of explosion.
- Do not use kerosene or other flammable solvents or combustible gases to flush the unit.
- Provide fresh air ventilation to avoid the buildup of flammable fumes from solvents or the fluid being sprayed.
- Keep the spray area free of debris, including solvent, rags, and gasoline.
- Before operating this equipment, electrically disconnect all equipment in the spray area.
- Before operating this equipment, extinguish all open flames or pilot lights in the spray area.
- Do not smoke in the spray area.
- Do not turn on or off any light switch in the spray area while spraying or while there are any fumes in the air.
- Do not operate a gasoline engine in the spray area.
- Keep a fire extinguisher in the work area.



MOVING PARTS HAZARD

Moving parts, such as the rotating blades of the agitator, can pinch or amputate your fingers or other body parts and can cause splashing in the eyes or on the skin.

- Keep clear of all moving parts when starting or operating the agitator.
- Always shut off the agitator and disconnect the air line before adjusting the angle of the agitator, removing the agitator from the drum, or checking or repairing any part of the agitator.



HAZARDOUS VAPORS

Hazardous fluids or toxic fumes can cause serious injury or death if splashed in the eyes or on the skin, swallowed, or inhaled. When flushing the air motor, keep your face away from the exhaust port.

Installation

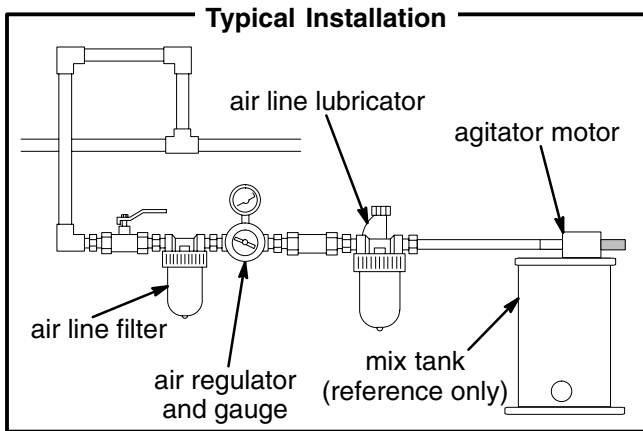

NOTES:

- Reference numbers and letters in parentheses refer to callouts in the figures and in the **Parts** drawings on pages 8 to 10.
- Accessories are available from your Graco Representatives you supply your own accessories, be sure they are adequately sized and pressure rated to meet the system's requirements.

Air Requirements

For continuous use, the 3/4 HP (550 W) agitator air motor typically requires 3 to 4 cfm (0.09 to 0.12 m³/min) air supply.

Air Line Accessories

Attach a quick-disconnect air line fitting and coupler, or attach a ball valve for main air shut-off to the air line. To order the 1/8" npt(m) air line fitting, order Part No. 169969. To order the coupler, order Part No. 208536.

Install an air line filter to remove harmful dirt and moisture from the air supply. To order an air line filter, order Part No. 106148 (3/8" npt, 20-micron element, 5 oz. bowl, without gauge).

⚠ CAUTION

Not lubricating the air motor will cause air motor failure.

Install an air line lubricator downstream from the filter for automatic air motor lubrication. Set the lubricator feed rate at 1 drop per minute for high speed or continuous duty usage. Do not overfeed oil or exhaust air may become contaminated. To manually lubricate the air motor, see **Lubricating the Air Motor** on page 7. To order a 3/8" npt air line lubricator, order Part No. 214847.

Installing the Agitator on the Drum

1. Loosen the protector cup set screw (9). See Fig. 2.
 2. Loosen the bottom clamp of the two clamps (12) on the rubber coupling (17). Both clamps are shown in the **Parts** drawings on pages 8 to 10.
 3. Uncouple the air motor (10) from the shaft (30) by loosening the bottom two screws of the four steel coupling set screws (4). All four screws are shown in the **Parts** drawings on pages 8 to 10.
 4. Remove the mounting hole cover plate from the drum cover.
 5. Install the mounting tube (35) with the gasket (29). (Mounting tube and gasket are included with Model 206219 only.)
 6. Fasten the mounting tube to the cover with the cover plate screws (A).
 7. Install the agitator shaft (30) up through the mounting tube, and recouple the air motor (10).
 8. Push the rubber coupling (17) over the mounting tube.
 9. Tighten the clamp (12).
 10. Slide the protector cup (22) up close to the bottom of the mounting tube, then tighten the set screw (9).
 11. *Model 203711*
Clamp the braces (26) to the agitator shaft guide (24) and the fluid pump tie rods.
 12. *Model 204995 and 206219*
Clamp the braces (31) to the agitator shaft guide (32) and the fluid pump housing or suction tube.
12. Place thread sealer on the threads of the air hose (27 or 33), and connect the hose between the needle valve (34) and the pump air inlet manifold. Refer to the parts drawing for your agitator model on pages 8 to 10.

Installation

Grounding

Proper grounding is an essential part of maintaining a safe system.

To reduce the risk of static sparking, the mounting cover and all electrically conductive objects or devices in the spray area **must** be properly grounded. Check your local electrical code for detailed grounding instructions for your area and type of equipment.

To ground the agitator, connect one end of the ground wire (A) to the ground connector (B) on the rim of the drum Cover. See Fig. 1. Connect the other end of the ground wire to a true earth ground.

For a ground wire and clamp, order Part No. 237569.

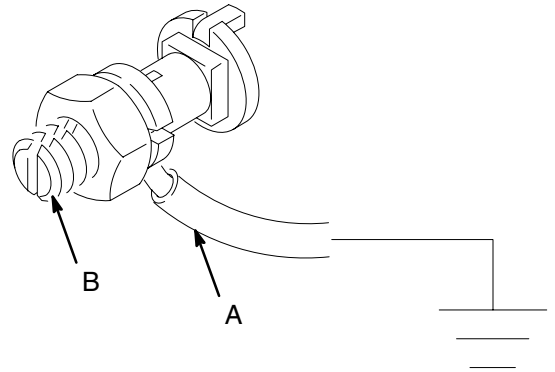

Fig. 1

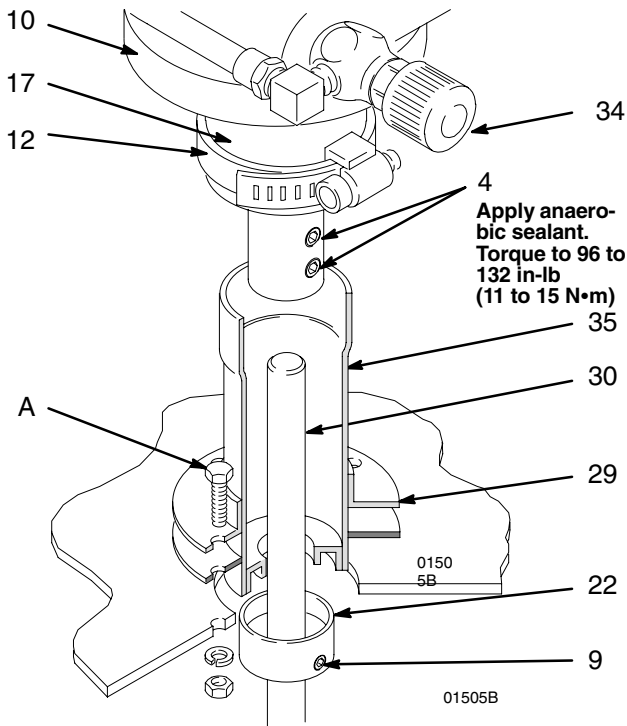
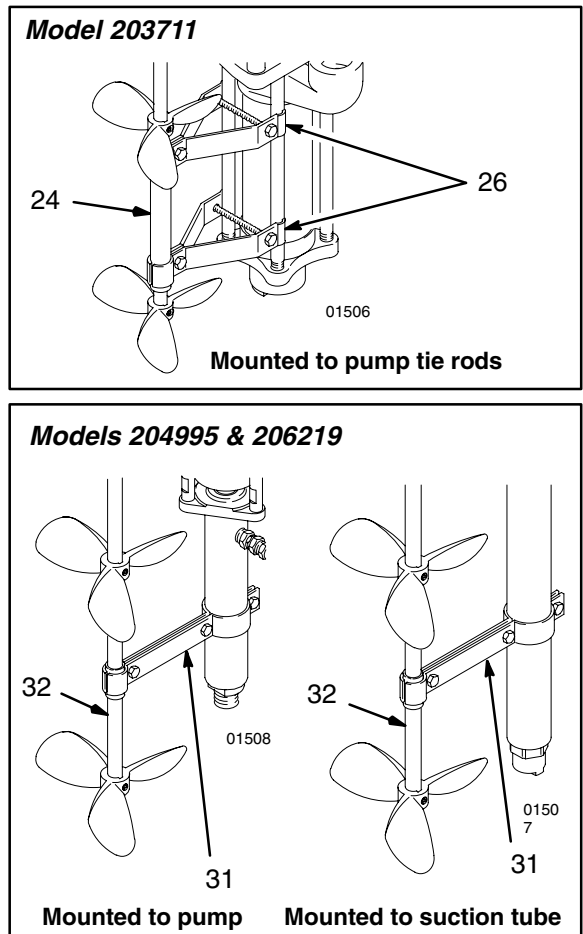

Fig. 2



Operation

Finding the Proper Agitator Speed

WARNING



MOVING PARTS HAZARD

To reduce the risk of serious injury, including cuts, amputation of fingers, and splashing in the eyes or on the skin, always shut off the agitator and disconnect the air line before checking or repairing the agitator.

NOTE: Attach ground wire before using agitator.

1. Fill the fluid supply container to about 3 or 4 inches (75 to 100 mm) above the agitator blade.
2. Start the agitator, and gradually increase the speed by turning the needle valve (34) until a vortex begins to form in the paint.
3. Reduce the speed slightly, then fill the fluid container.

NOTE: If an air shut-off valve is installed in the supply line and used to stop and start the agitator, the same agitator speed will be set each time the agitator is used without repeating the above procedure. Order **air shut-off valves** by the part numbers listed below:

208390 1/4" npt(m) x 1/4" npt(m)

208391 3/8" npt(m) x 3/8" npt(f)

208392 3/8" npt(f) x 1/4" npt(m)

208393 3/8" npt(m) x 3/8" npt(m)

Operating the Agitator

CAUTION

Do not operate the agitator at a high speed for a long period of time. Excessive agitator speed can cause the paint to foam and increase the wear on the agitator parts.



Operate the agitator continuously while supplying paints or other fluids to the System. Use the needle valve (34) to regulate the agitator Speed. Set the agitator speed to thoroughly mix the paint, using the lowest speed possible.



To stop the agitator, close the air valve in the air supply line if you have one, or close the needle valve (34).

Turn the agitator off before removing it from the pail.

Service

Flushing the Air Motor

 WARNING	
	FIRE AND EXPLOSION HAZARD Do not use kerosene or other flammable solvents to flush the air motor. Flushing with flammable solvents could cause fire or explosion and result in serious injury or property damage.

 WARNING	
	HAZARDOUS VAPORS Hazardous fluids or toxic fumes can cause serious injury or death if splashed in the eyes or on the skin, swallowed, or inhaled. When flushing the air motor: <ul style="list-style-type: none">● Keep your face away from the exhaust port.● Wear the appropriate protective clothing, gloves, eyewear, and respirator.

If the motor is sluggish or inefficient, flush it with non-flammable solvent in a well ventilated area.

The recommended solvent for air motors and lubricated pumps is Gast® Flushing Solvent (Part No. AH255 or AH255A) or Inhibisol® Safety Solvent.

1. Disconnect the air line and muffler.
2. Add several teaspoons of solvent or spray the solvent directly into the motor.

3. Rotate the shaft by hand in both directions for a few minutes.
4. Reconnect the air line, and slowly increase the air pressure until there is no trace of solvent in the exhaust air.
5. Re-lubricate the motor with a squirt of light-weight oil in the chamber.

Gast® is a registered trademark of Gast Manufacturing.

Inhibisol® is a registered trademark of Penetone Corp.

Servicing

- If the unit requires more than installation of a service kit, it is usually quickest and easiest to send the unit to the Graco distributor for repair or replacement.
- If the vanes need replacing, or if foreign material is present in the motor chamber, an experienced mechanic may remove the end plate opposite the drive shaft end. *Do not pry with a screwdriver. It will dent the surface of the plate and body, causing leaks.* Use a puller tool, which will remove the end plate while maintaining the position of the shaft.
- New vanes should have the edges with cut corners (or the notched edges, if the vanes are reversible) pointing toward the bottom of the vane slot.

Lubricating the Air Motor

 CAUTION
Not lubricating the air motor will cause air motor failure.

If an air line lubricator is not installed, the air motor must be manually lubricated every 8 hours. Lubricate the agitator air motor by placing 10–20 drops of SAE #10 light oil in the motor's air inlet. Run the agitator for about 30 seconds.

Parts for Model 203711

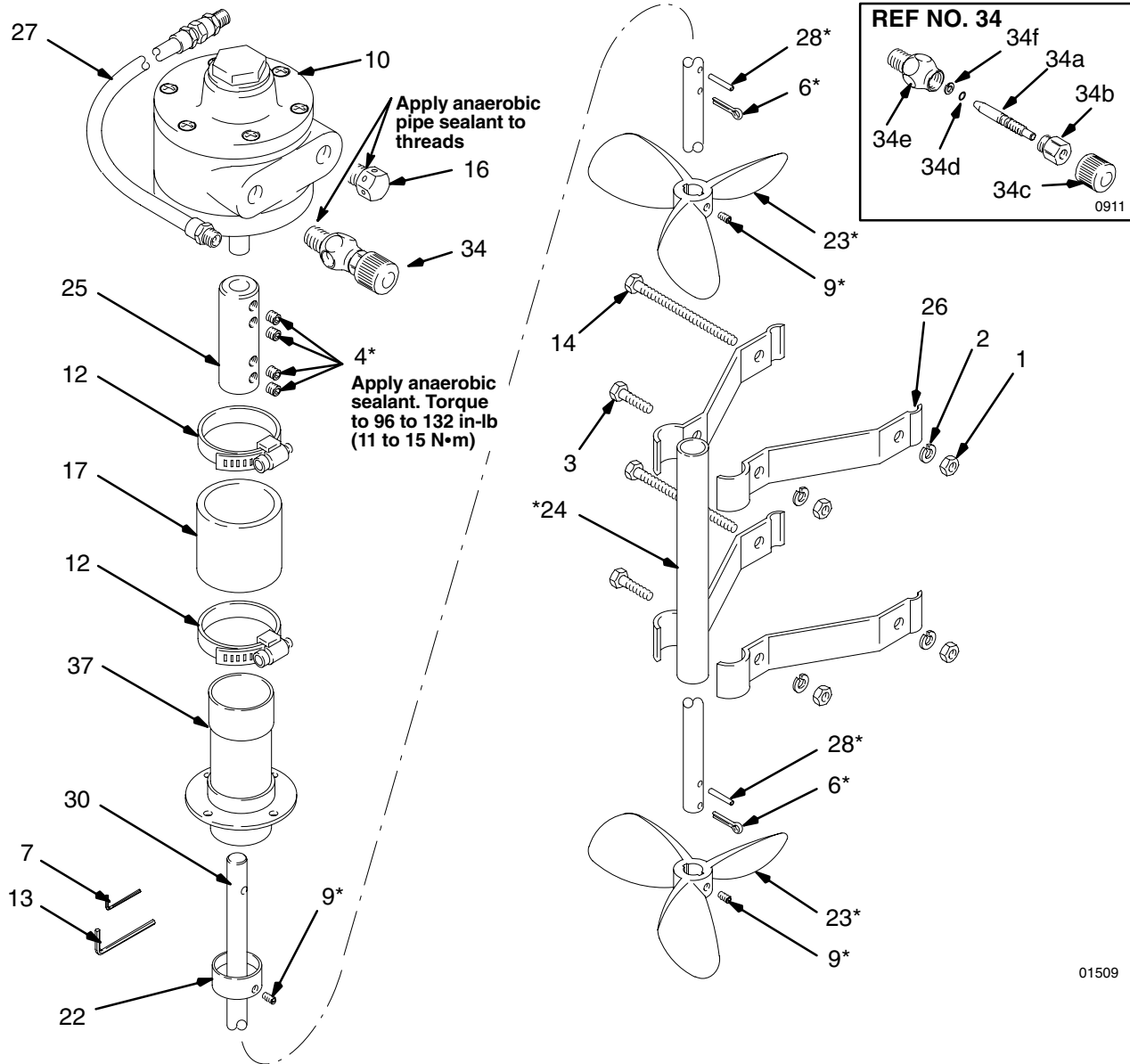

01509

Ref. No.	Part No.	Description	Qty.	Ref. No.	Part No.	Description	Qty.
1	100015	NUT, hex; 1/4-20	4	27	206749	HOSE, air; cpld 1/8" npt; 1/4" npt (mbe); 1/4" (6.4 mm) ID; 36" (914 mm) long	1
2	100016	LOCKWASHER, spring; 1/4"	4	28*	160077	PIN, shear; 0.12" (3.2 mm) dia; 3/4" (19 mm) long	2
3	100021	SCREW, hex hd cap; 1/4-20 x 3/4" (19 mm)	2	30	172311	SHAFT	1
4*	100053	SCREW, soc hd cup pt set; 5/16-18 x 1/4" (6.4 mm)	4	34	206264	NEEDLE VALVE ASSY., Includes items 34a-f	1
6*	100579	PIN, cotter; 0.11" (2.8 mm) dia; 1" (25 mm) long	2	34a	166529	.VALVE, needle	1
7	100633	WRENCH, hex key; 5/16	1	34b	166532	.NUT, packing	1
9*	101118	SCREW, soc hd cup pt set; #10-24 x 1/4" (6.4 mm)	3	34c	164698	.KNOB, adjusting	1
10	101140	MOTOR, air; 3/4 HP (550 W)	1	34d	157628	.O-RING, packing	1
12	101368	CLAMP, hose	2	34e	165722	.BODY, valve	1
13	101369	WRENCH, hex key; #10	1	34f	166531	.WASHER	1
14	103195	SCREW, hex hd cap; 1/4-20 x 4" (101.6 mm)	2	35	208536	COUPLING, air line (not shown)	1
16	156969	MUFFLER, air motor	1	36	169969	FITTING, air line (not shown)	1
17	158865	COUPLING, air motor; rubber	1	37	204635	GUIDE, agitator (2.5" (63.5 mm) bolt hole mounting pattern)	1
22	159704	CUP, bearing protector	1	38	100268	SCREW, pan-head (not shown)	4
23*	159854	PROPELLOR, agitator, aluminum	2	39	C38163	WASHER, lock, ext. tooth (not shown)	4
24*	159856	GUIDE, shaft	1	40	100179	NUT, hex (not shown)	4
25	159858	COUPLING, steel	1				
26	160021	STRAP, brace	4				

* Keep spares of these parts on hand to reduce down time.

Parts for Model 204995

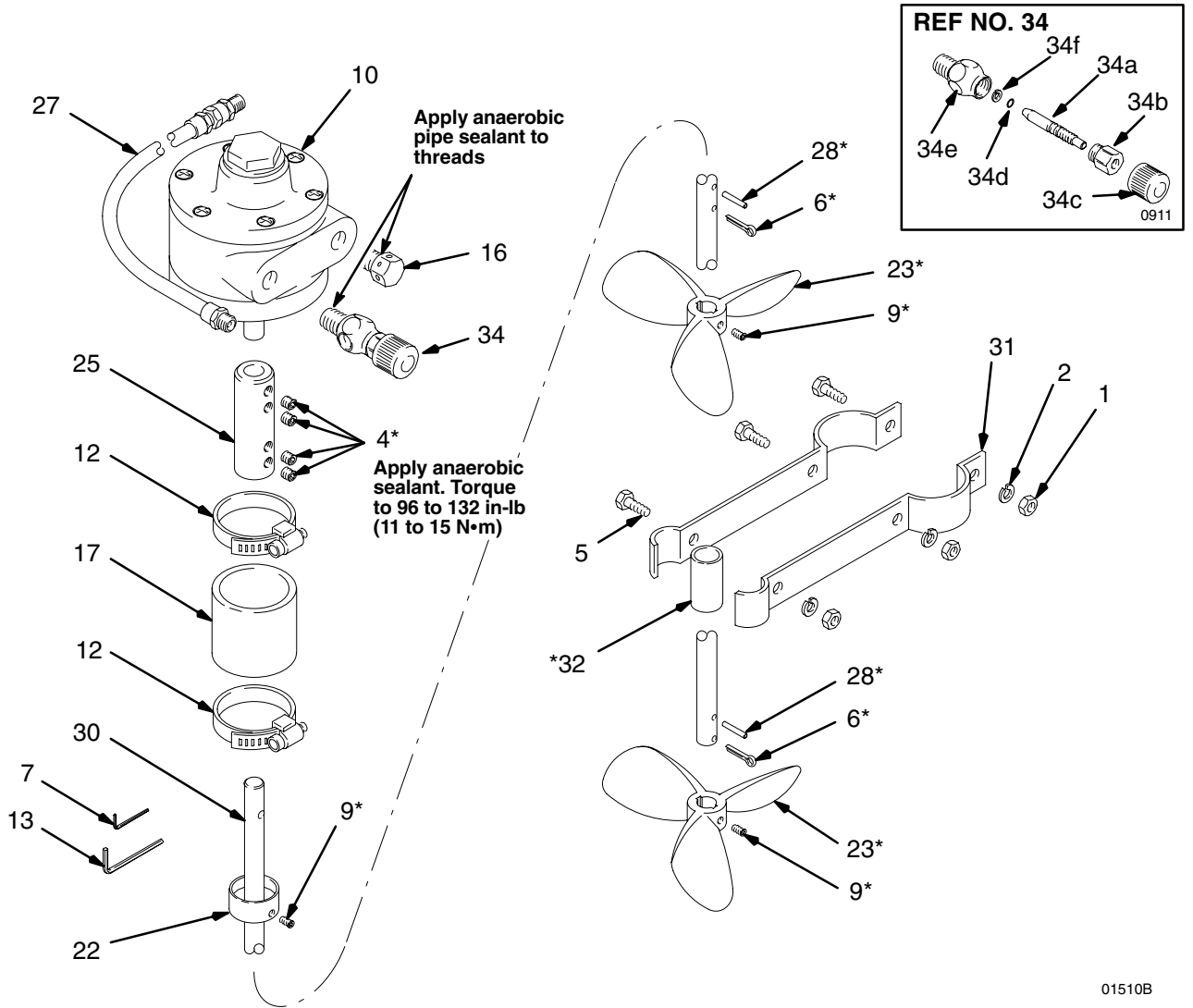

01510B

Ref. No.	Part No.	Description	Qty.	Ref. No.	Part No.	Description	Qty.
1	100015	NUT, hex; 1/4-20	3	28*	160077	PIN, shear; 0.12" (3.2 mm) dia; 3/4" (19 mm) long	2
2	100016	LOCKWASHER, spring; 1/4"	3	30	172311	SHAFT	1
4*	100053	SCREW, soc hd cup pt set; 5/16-18 x 1/4" (6.4 mm)	4	31	162498	STRAP, brace	2
5	100270	SCREW, hex hd cap; 1/4-20 x 5/8" (15.9 mm)	3	32*	162499	GUIDE	1
6*	100579	PIN, cotter; 0.11" (2.8 mm) dia; 1" (25 mm) long	2	34	206264	NEEDLE VALVE ASSY., Includes items 34a-f	1
7	100633	WRENCH, hex key; 5/16	1	34a	166529	.VALVE, needle	1
9*	101118	SCREW, soc hd cup pt set; #10-24 x 1/4" (6.4 mm)	3	34b	166532	.NUT, packing	1
10	101140	MOTOR, air; 3/4 HP (550 W)	1	34c	164698	.KNOB, adjusting	1
12	101368	CLAMP, hose	2	34d	157628	.O-RING, packing	1
13	101369	WRENCH, hex key; #10	1	34e	165722	.BODY, valve	1
16	156969	MUFFLER, air motor	1	34f	166531	.WASHER	1
17	158865	COUPLING, air motor; rubber	1	35	208536	COUPLING, air line (not shown)	1
22	159704	CUP, bearing protector	1	36	169969	FITTING, air line (not shown)	1
23*	159854	PROPELLOR, agitator, aluminum	2				
25	159858	COUPLING, steel	1				
27	206749	HOSE, air; cpld 1/8" npt; 1/4" npt (mbe); 1/4" (6.4 mm) ID; 36" (914 mm) long	1				

* Keep spares of these parts on hand to reduce down time.

Parts for Model 206219

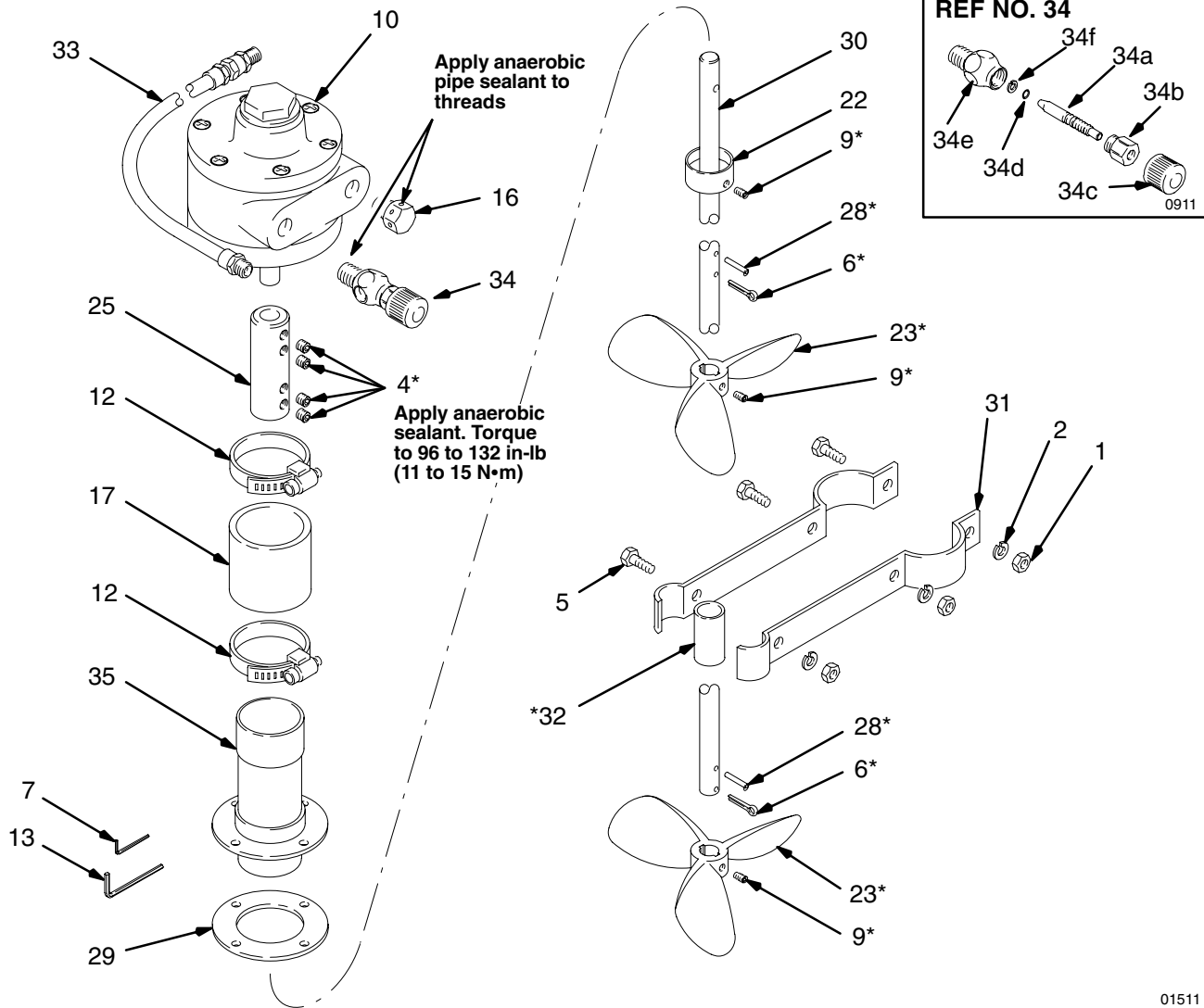

01511

Ref. No.	Part No.	Description	Qty.	Ref. No.	Part No.	Description	Qty.
1	100015	NUT, hex; 1/4-20	3	29	161457	GASKET, mounting tube	1
2	100016	LOCKWASHER, spring; 1/4"	3	30	172311	SHAFT	1
4*	100053	SCREW, soc hd cup pt set; 5/16-18 x 1/4" (6.4 mm)	4	31	162498	STRAP, brace	2
5	100270	SCREW, hex hd cap; 1/4-20 x 5/8" (15.9 mm)	3	32*	162499	GUIDE	1
6*	100579	PIN, cotter; 0.11" (2.8 mm) dia; 1" (25 mm) long	2	33	206749	HOSE, air; cpld 1/8" npt; 1/4" npt (mbe); 1/4" (6.4 mm) ID; 36" (914 mm) long	1
7	100633	WRENCH, hex key; 5/16	1	34	206264	NEEDLE VALVE ASSY., Includes items 34a-f	1
9*	101118	SCREW, soc hd cup pt set; #10-24 x 1/4" (6.4 mm)	3	34a	166529	.VALVE, needle	1
10	101140	MOTOR, air; 3/4 HP (550 W)	1	34b	166532	.NUT, packing	1
12	101368	CLAMP, hose	2	34c	164698	.KNOB, adjusting	1
13	101369	WRENCH, hex key; #10	1	34d	157628	.O-RING, packing	1
16	156969	MUFFLER, air motor	1	34e	165722	.BODY, valve	1
17	158865	COUPLING, air motor; rubber	1	34f	166531	.WASHER	1
22	159704	CUP, bearing protector	1	35	204635	TUBE, agitator mounting (2.5" (63.5 mm) bolt hole mounting pattern)	1
23*	159854	PROPELLOR, agitator, aluminum	2	36	208536	COUPLING, air line (not shown)	1
25	159858	COUPLING, steel	1	37	169969	FITTING, air line (not shown)	1
28*	160077	PIN, shear; 0.12" (3.2 mm) dia; 3/4" (19 mm) long	2				

* Keep spares of these parts on hand to reduce down time.

Technical Data

Maximum working pressure 100 psi (7 bar, 0.7 MPa)
Motor power rating 3/4 HP (550 W)
Overall height 41 in. (1041 mm)
Wetted parts carbon steel, aluminum

*Sound data:

Sound level at 800 RPM, 100 psi (7 bar, 0.7 MPa), normal load
Pressure level 65.0 dB(A)
Power level 73.9 dB(A)

Sound level at maximum RPM, 100 psi
(7 bar, 0.7 MPa), no load
Pressure level 82.1 dB(A)
Power level 91.0 dB(A)

Weight:

Model 203711 12 lb (5.4 kg)
Models 204995 and 206219 11 lb (5 kg)

* *Tested to CAGI-PNEUROP-1969*

Graco Warranty

Graco warrants all equipment listed in this manual which is manufactured by Graco and bearing its name to be free from defects in material and workmanship on the date of sale to the original purchaser for use. With the exception of any special extended or limited warranty published by Graco, Graco will, for a period of twelve months from the date of sale, repair or replace any part of the equipment determined by Graco to be defective. This warranty applies only when the equipment is installed, operated and maintained in accordance with Graco's written recommendations.

This warranty does not cover, and Graco shall not be liable for general wear and tear, or any malfunction, damage or wear caused by faulty installation, misapplication, abrasion, corrosion, inadequate or improper maintenance, negligence, accident, tampering, or substitution of non-Graco component parts. Nor shall Graco be liable for malfunction, damage or wear caused by the incompatibility of Graco equipment with structures, accessories, equipment or materials not supplied by Graco, or the improper design, manufacture, installation, operation or maintenance of structures, accessories, equipment or materials not supplied by Graco.

This warranty is conditioned upon the prepaid return of the equipment claimed to be defective to an authorized Graco distributor for verification of the claimed defect. If the claimed defect is verified, Graco will repair or replace free of charge any defective parts. The equipment will be returned to the original purchaser transportation prepaid. If inspection of the equipment does not disclose any defect in material or workmanship, repairs will be made at a reasonable charge, which charges may include the costs of parts, labor, and transportation.

Graco's sole obligation and buyer's sole remedy for any breach of warranty shall be as set forth above. The buyer agrees that no other remedy (including, but not limited to, incidental or consequential damages for lost profits, lost sales, injury to person or property, or any other incidental or consequential loss) shall be available. Any action for breach of warranty must be brought within two (2) years of the date of sale.

GRACO MAKES NO WARRANTY, AND DISCLAIMS ALL IMPLIED WARRANTIES OF MERCHANTABILITY AND FITNESS FOR A PARTICULAR PURPOSE IN CONNECTION WITH ACCESSORIES, EQUIPMENT, MATERIALS OR COMPONENTS SOLD BUT NOT MANUFACTURED BY GRACO. These items sold, but not manufactured by Graco (such as electric motors, gas engines, switches, hose, etc.), are subject to the warranty, if any, of their manufacturer. Graco will provide purchaser with reasonable assistance in making any claim for breach of these warranties.

In no event will Graco be liable for indirect, incidental, special or consequential damages resulting from Graco supplying equipment hereunder, or the furnishing, performance, or use of any products or other goods sold hereto, whether due to a breach of contract, breach of warranty, the negligence of Graco, or otherwise.

FOR GRACO CANADA CUSTOMERS

The parties acknowledge that they have required that the present document, as well as all documents, notices and legal proceedings entered into, given or instituted pursuant hereto or relating directly or indirectly hereto, be drawn up in English. Les parties reconnaissent avoir convenu que la rédaction du présente document sera en Anglais, ainsi que tous documents, avis et procédures judiciaires exécutés, donnés ou intentés à la suite de ou en rapport, directement ou indirectement, avec les procédures concernées.

Graco Information

TO PLACE AN ORDER, contact your Graco distributor, or call one of the following numbers to identify the distributor closest to you:

1-800-328-0211 Toll Free

612-623-6921

612-378-3505 Fax

*All written and visual data contained in this document reflects the latest product information available at the time of publication.
Graco reserves the right to make changes at any time without notice.*

This manual contains English. MM 306459

Graco Headquarters: Minneapolis

International Offices: Belgium, China, Japan, Korea

GRACO INC. P.O. BOX 1441 MINNEAPOLIS, MN 55440-1441

www.graco.com

04/1954, Revised 08/2007