

Heavy Fluid Air Spray Gun 306494K

2000 psi (14.0 MPa, 140 bar) Maximum Fluid Working Pressure
100 psi (0.7 MPa, 7 bar) Maximum Air Working Pressure

Part No. 204000, Series J

With 1/4 size cap and tip (round type)



Read warnings and instructions.

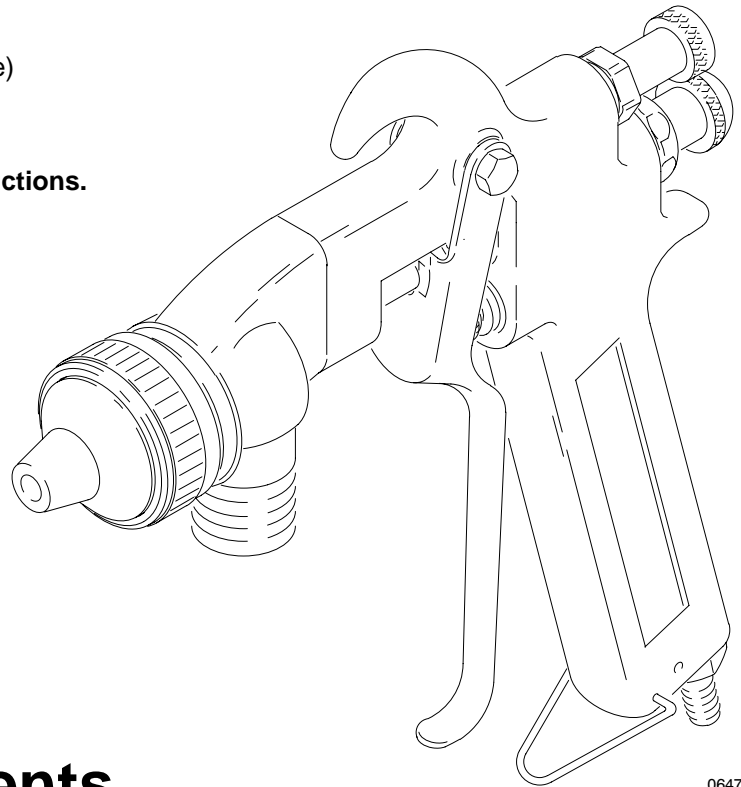

06474

Table of Contents

Warnings	2
Installation	4
Operation	5
Maintenance	5
Service	6
Parts	7
Technical Data	9
Graco Standard Warranty	10
Graco Information	10

PROVEN QUALITY. LEADING TECHNOLOGY.

Symbols

Warning Symbol



This symbol alerts you to the possibility of serious injury or death if you do not follow the instructions.

Caution Symbol



This symbol alerts you to the possibility of damage to or destruction of equipment if you do not follow the instructions.

WARNING



INSTRUCTIONS

EQUIPMENT MISUSE HAZARD

Equipment misuse can cause the equipment to rupture, malfunction, or start unexpectedly and result in serious injury.

- This equipment is for professional use only.
- Read all instruction manuals, tags, and labels before operating the equipment.
- Use the equipment only for its intended purpose. If you are uncertain about usage, call your Graco distributor.
- Do not alter or modify this equipment. Use only genuine Graco parts and accessories.
- Check the equipment daily. Repair or replace worn or damaged parts immediately.
- Do not exceed the maximum working pressure of the lowest rated system component. This equipment has a **2000 psi (14.0 MPa, 140 bar) maximum fluid working pressure and a 100 psi (0.7 MPa, 7 bar) maximum air working pressure.**
- Do not lift pressurized equipment.
- Route the hoses away from the traffic areas, sharp edges, moving parts, and hot surfaces. Do not expose Graco hoses to temperatures above 180°F (82°C) or below -40°F (-40°C).
- Do not use the hoses to pull the equipment.
- Use only Graco approved hoses. Do not remove hose spring guards, which help protect the hose from rupture caused by kinks or bends near the couplings.
- Use fluids or solvents that are compatible with the equipment wetted parts. See the **Technical Data** section of all the equipment manuals. Read the fluid and solvent manufacturer's warnings.
- Never use 1,1,1-trichloroethane, methylene chloride, other halogenated hydrocarbon solvents, or fluids containing such solvents in pressurized aluminum equipment. Such use could result in a chemical reaction, with the possibility of explosion.
- Wear hearing protection when operating this equipment.
- Comply with all applicable local, state, and national fire, electrical, and other safety regulations.



TOXIC FLUID HAZARD

Hazardous fluid or toxic fumes can cause serious injury or death if splashed in the eyes or on the skin, inhaled, or swallowed.

- Know the specific hazards of the fluid you are using.
- Store hazardous fluid in an approved container. Dispose of hazardous fluid according to all local, state, and national guidelines.
- Always wear protective eyewear, gloves, clothing, and respirator as recommended by the fluid and solvent manufacturer.

WARNING



FIRE AND EXPLOSION HAZARD

Improper grounding, poor air ventilation, open flames, or sparks can cause a hazardous condition and result in fire or explosion and serious injury.

- Ground the equipment and the object being sprayed. See **Ground the System** on page 4.
- Provide fresh air ventilation to avoid the buildup of flammable fumes from solvent or the fluid being sprayed.
- Extinguish all the open flames or pilot lights in the spray area.
- Electrically disconnect all the equipment in the spray area.
- Keep the spray area free of debris, including solvent, rags, and gasoline.
- Do not turn on or off any light switch in the spray area while operating or if fumes are present.
- Do not smoke in the spray area.
- Do not operate a gasoline engine in the spray area.
- If there is any static sparking while using the equipment, **stop spraying immediately**. Identify and correct the problem.



INJECTION HAZARD

Spray from the gun, hose leaks, or ruptured components can inject fluid into your body and cause an extremely serious injury, including the need for amputation. Splashing fluid in the eyes or on the skin can also cause a serious injury.

- Fluid injected into the skin might look like just a cut, but it is a serious injury. **Get immediate surgical treatment.**
- Do not point the spray gun at anyone or at any part of the body.
- Do not put hand or fingers over the spray tip.
- Do not stop or deflect fluid leaks with your hand, body, glove, or rag.
- Do not “blow back” fluid; this is not an air spray system.
- Always have the tip guard and the trigger guard on the spray gun when spraying.
- Be sure the gun trigger safety operates before spraying.
- Lock the gun trigger safety when you stop spraying.
- Follow the **Pressure Relief Procedure** on page 5 whenever you: are instructed to relieve pressure; stop spraying; clean, check, or service the equipment; and install or clean the spray tip.
- Tighten all the fluid connections before operating the equipment.
- Check the hoses, tubes, and couplings daily. Replace worn, damaged, or loose parts immediately. Permanently coupled hoses cannot be repaired; replace the entire hose.

Installation

General

NOTE: Reference numbers and letters in parentheses in the text refer to the callouts in the Parts Drawing.

WARNING

For your safety, read and understand all warnings and instructions in this manual and in all manuals supplied with every component of your spray system before operating the system.

Install the Gun Accessories

- Install an air line filter to ensure a clean, dry air supply to the gun. Dirt and moisture in the line can ruin the appearance of your finished piece.
- Install an air pressure regulator on the gun air supply line to control the air pressure to the gun.
- Install an air pressure regulator on the pump air supply line to control air pressure to the pump.
- Install a bleed-type air shutoff valve on the main air line and on the pump air line, downstream of the pump air regulator, to shut off air to the pump.
- Install an air shutoff valve on the gun air supply line, downstream of the gun air regulator, to shut off air to the gun.
- Connect the air hose from the air supply to the 3/8 npsm gun air inlet fitting. Always use a wrench on the air inlet fitting when connecting the supply hose. Failure to properly support this fitting may result in overtightening and damage to the gun.

WARNING



INJECTION HAZARD

To reduce the risk of property damage or serious injury, including fluid injection:

- a fluid drain valve is required in your system to assist in relieving fluid pressure in the displacement pump, hose, and gun; triggering the gun may not be sufficient.

- Install a fluid filter and drain valve close to the pump's fluid outlet. The fluid filter helps prevent the spray tip from clogging with particles from the fluid.
- Install a fluid pressure regulator to control pressure to the gun.
- Install a fluid shutoff valve to shut off the fluid supply to the gun.
- Connect the grounded fluid hose to the 3/4 npt gun fluid inlet in the gun head (7).

Ground the System

To reduce the risk of static sparking, ground the sprayer and all other spray equipment used or located in the spray area. Check your local electrical code for detailed grounding instructions for your area and type of equipment. Be sure to ground all of the following equipment.

- *Pump:* use a ground wire and clamp as explained in your separate pump instruction manual.
- *Air and fluid hoses:* use only grounded fluid hoses.
- *Spray gun:* obtain grounding through connection to a properly grounded fluid hose and pump.
- *Object being sprayed:* follow your local code.
- *Fluid supply container:* follow your local code.
- *All solvent pails used when flushing,* according to local code. Use only metal pails, which are conductive. Do not place the pail on a non-conductive surface, such as paper or cardboard, which interrupts the grounding continuity.
- *To maintain grounding continuity when flushing or relieving pressure,* always hold a metal part of the gun firmly to the side of a grounded metal waste container and use the lowest possible fluid pressure during flushing.

Operation

Pressure Relief Procedure

⚠ WARNING



INJECTION HAZARD
Fluid under high pressure can be injected through the skin and cause serious injury. To reduce the risk of an injury from injection, splashing fluid, or moving parts, follow the **Pressure Relief Procedure** whenever you:

- are instructed to relieve the pressure,
- stop spraying,
- check or service any of the system equipment,
- or install or clean the fluid tips.

1. Shut off the power to the pump.
2. Close the pump's bleed-type master air valve (required in your system).
3. Hold a metal part of the gun firmly to the side of a grounded metal waste container, and trigger the gun to relieve pressure.
4. Open the pump drain valve (required in your system), having a container ready to catch the drainage. Leave the valve open until you are ready to spray again.

If you suspect that the fluid tip or hose is completely clogged, or that pressure has not been fully relieved after following the steps above, very slowly loosen the hose end coupling to relieve pressure gradually. Then, loosen completely and clear the tip or hose.

Gun Operation

⚠ WARNING



INJECTION HAZARD
To reduce the risk of property damage or serious injury, including fluid injection:

- keep your fingers, hands, and body away from the fluid tip and air cap.
- do not wipe build-up off the fluid tip or air cap until pressure is fully relieved.
- follow the **pressure relief procedure** at left.

1. Remove the lockring (12) and air cap (11) when priming the system. This prevents fluid from being forced into the gun air passages.
2. Aim the gun into an empty container and trigger it while slowly opening the system's master air valve. Run the pump slowly until the system is fully primed. Release the trigger.
3. Set the gun air regulator to about 40 psi (0.28 MPa, 2.8 bar) as a trial setting. Test the spray pattern and adjust the pump and gun air regulators until you get a good spray pattern.
4. Use the air adjusting screw (22) for fine adjustment of the fluid atomization. Turn the screw outward to increase the air volume, or inward to decrease it.
5. To extend the pump and tip life, do not use higher air or fluid pressure than necessary.
6. Adjust the trigger tension by turning the fluid valve screw (17) in or out.
7. **Relieve the pressure** when you stop spraying.

Maintenance

Flushing

⚠ WARNING

To reduce the risk of serious injury, whenever you are instructed to relieve pressure, always follow the **Pressure Relief Procedure** above.

⚠ CAUTION

For maximum gun life, clean the gun frequently. Do not immerse the entire gun in solvent. Prolonged exposure to solvent will damage the fluid packing. If you want to soak the nozzle, remove the air cap and place only the front of the gun in solvent.

1. **Relieve the pressure.**
2. Remove the fluid tip and air cap and clean them separately.
3. Flush the gun thoroughly, using the lowest possible pressure and a compatible solvent.

Lubrication

Every day, apply a few drops of light machine oil to the exposed portion of the fluid valve stem (32) and the air valve stem (34).

Service

Air is Leaking Around the Air Valve

WARNING

To reduce the risk of serious injury whenever you are instructed to relieve pressure, always follow the **Pressure Relief Procedure** on page 5.

Note: Repair Kit 215936 is available for replacing the air valve spring, poppet, and stem. Parts included in the kit are marked with an asterisk, for example (30*).

1. Remove the trigger screw (1), pivot pin (9), and trigger (24). See the Parts Drawing on page 7.
2. Unscrew the nut (14). Grasp the seat (15) and pull it out. Remove the remaining parts.
3. Check for worn or damaged parts and replace as necessary. Lubricate all packings, o-rings, and moving parts.

Fluid is Leaking Around the Packing Nut

Notes:

- Try tightening the packing nut (23) first. If that does not resolve the problem, repack the gun as instructed below.
 - Repair Kit 215937 is available for repacking the gun. Parts included in the kit are marked with a dagger, for example (27†).
1. Remove the lockring (12), air cap (11), and fluid tip (31).
 2. Remove the trigger screw (1), pivot pin (9), and trigger (24).
 3. Unscrew the air control housing (21). Use a 3/8 in. hex key wrench to unscrew the head bolt (19).
 4. Unscrew the spring and valve guide (18). Remove the gasket (3) and o-ring (6†).
 5. Unscrew the packing nut (23).
 6. Grasp the valve stem (32) and pull it out the front of the gun.
 7. Use a pick to remove the packings (26†) from the rear of the head (7).
 8. Clean all parts and inspect for wear or damage. Replace parts as necessary.
 9. Lubricate all packings, o-rings, and moving parts and then reassemble the gun. Tighten the packing nut (23) enough to prevent leaking, but do not over-compress the packings.

Parts

Model 204000, Series J

Includes items 1 to 34

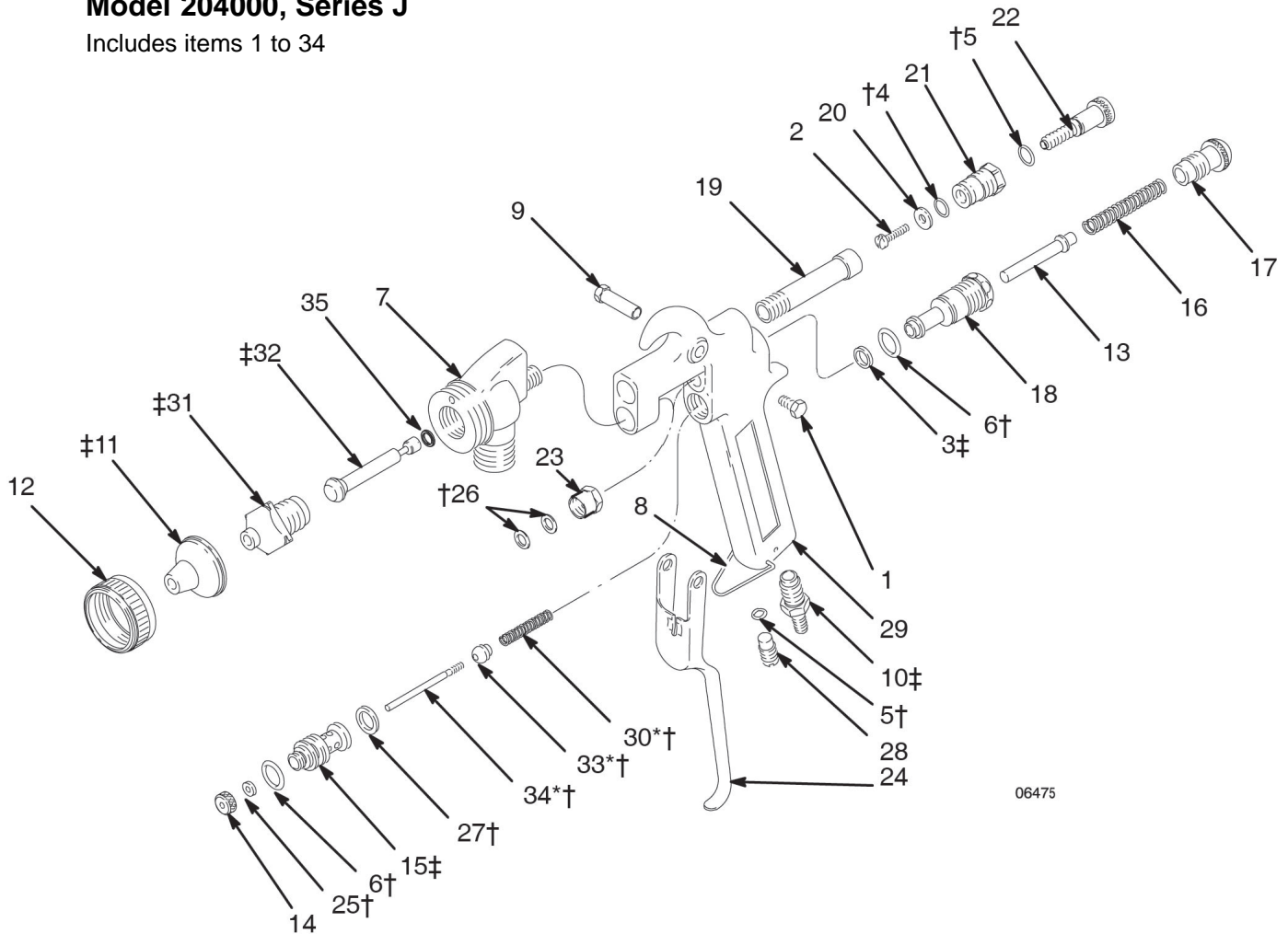

06475

Ref No.	Part No.	Description	Qty.	Ref No.	Part No.	Description	Qty.
1	203953	LOCK SCREW; trigger	1	21	160235	AIR CONTROL HOUSING	1
2	101543	SCREW, rd hd mach; no 8-32 thd size; 3/8" lg	1	22	160236	SCREW, air adjusting	1
3‡	150925	GASKET, copper	1	23	160238	PACKING NUT; fluid stem	1
4†	154594	O-RING; nitrile rubber	1	24	160239	TRIGGER	1
5†	154741	O-RING; nitrile rubber	2	25†	160240	PACKING; leather; air valve stem	1
6†	156082	O-RING; nitrile rubber	2	26†	160241	PACKING; leather; fluid valve	1
7	188445	HEAD, spray gun	1	27†	160910	stem WASHER, non-metallic	1
8	160215	TRIGGER LATCH	1	28	161274	PLUG, aluminum	1
9	160217	PIVOT PIN	1	29	161280	BODY, gun	1
10‡	160222	AIR INLET ADAPTER; 3/8 npsm	1	30*†	161319	SPRING, compression; air valve	1
11‡	160224	AIR CAP	1	31‡	167330	TIP; fluid	1
12	160225	LOCK RING, nozzle	1	32‡	167332	VALVE STEM, fluid valve	1
13	160227	PUSH ROD, fluid valve	1	33*†	177139	POPPET, valve, Delrin	1
14	160228	PACKING NUT, air valve stem	1	34*†	169643	STEM, air valve	1
15‡	160229	SEAT, air valve	1	35	111967	PACKING, quad-ring	1
16	160230	SPRING, compression; fluid valve	1	* Supplied in Repair Kit 215936.			
17	160231	SCREW; fluid valve regulating	1	† Supplied in Repair Kit 215937			
18	160232	GUIDE, spring and valve	1	‡ Recommended 'Tool Box' spare parts. Keep these parts on hand to reduce down time.			
19	160233	BOLT, head	1				
20	160234	WASHER, brass	1				

Technical Data

Category	Data
Length	8 in. (203 mm)
Height	8.25 in (210 mm)
Weight	3.5 lbs (1.6 Kg)
Maximum Air Working Pressure	100 psi (0.7 MPa) (7 bar)
Maximum Fluid Working Pressure	2000 psi (14.0 MPa) (140 bar)
Maximum Fluid Working Temperature	120° F (49° C)
Wetted Parts	Aluminum, Stainless Steel, Steel, Leather, Delrin®
Fluid Inlet	3/4 npt(m)
Air Inlet	3/8 npsm(m)
Sound Pressure at 1500 psi (10.5 MPa, 105 bar)	89 dB(A)
Sound Pressure at 2000 psi (1.4 MPa, 140 bar)	94 dB(A)
Sound Power at 1500 psi (10.5 MPa, 105 bar)	101 dB(A)
Sound Power at 2000 psi (1.4 MPa, 140 bar)	106 dB(A)

Delrin® is a trademark of the DuPont Company.

Accessories

Round Type			Slotted Type			Horn Type			Rubber Insert Type		
Size	Air Cap	Fluid Tip	Size	Air Cap	Fluid Tip	Size	Air Cap	Fluid Tip	Size	Rubber Insert	Fluid Tip
1/8	160656	167328	1/8	160661	167328						
3/16	160657	167329	3/16	160662	167329	3/16	160659	167329			
1/4	160224*	167330*				1/4	160321	167330	1/4	160664	167330
			3/8	160663	167331	3/8	160660	167331	3/8	160665	167331

* Included in Model 204000

Graco Standard Warranty

Graco warrants all equipment manufactured by Graco and bearing its name to be free from defects in material and workmanship on the date of sale by an authorized Graco distributor to the original purchaser for use. With the exception of any special, extended, or limited warranty published by Graco, Graco will, for a period of twelve months from the date of sale, repair or replace any part of the equipment determined by Graco to be defective. This warranty applies only when the equipment is installed, operated and maintained in accordance with Graco's written recommendations.

This warranty does not cover, and Graco shall not be liable for general wear and tear, or any malfunction, damage or wear caused by faulty installation, misapplication, abrasion, corrosion, inadequate or improper maintenance, negligence, accident, tampering, or substitution of non-Graco component parts. Nor shall Graco be liable for malfunction, damage or wear caused by the incompatibility of Graco equipment with structures, accessories, equipment or materials not supplied by Graco, or the improper design, manufacture, installation, operation or maintenance of structures, accessories, equipment or materials not supplied by Graco.

This warranty is conditioned upon the prepaid return of the equipment claimed to be defective to an authorized Graco distributor for verification of the claimed defect. If the claimed defect is verified, Graco will repair or replace free of charge any defective parts. The equipment will be returned to the original purchaser transportation prepaid. If inspection of the equipment does not disclose any defect in material or workmanship, repairs will be made at a reasonable charge, which charges may include the costs of parts, labor, and transportation.

THIS WARRANTY IS EXCLUSIVE, AND IS IN LIEU OF ANY OTHER WARRANTIES, EXPRESS OR IMPLIED, INCLUDING BUT NOT LIMITED TO WARRANTY OF MERCHANTABILITY OR WARRANTY OF FITNESS FOR A PARTICULAR PURPOSE.

Graco's sole obligation and buyer's sole remedy for any breach of warranty shall be as set forth above. The buyer agrees that no other remedy (including, but not limited to, incidental or consequential damages for lost profits, lost sales, injury to person or property, or any other incidental or consequential loss) shall be available. Any action for breach of warranty must be brought within two (2) years of the date of sale.

Graco makes no warranty, and disclaims all implied warranties of merchantability and fitness for a particular purpose in connection with accessories, equipment, materials or components sold but not manufactured by Graco. These items sold, but not manufactured by Graco (such as electric motors, switches, hose, etc.), are subject to the warranty, if any, of their manufacturer. Graco will provide purchaser with reasonable assistance in making any claim for breach of these warranties.

In no event will Graco be liable for indirect, incidental, special or consequential damages resulting from Graco supplying equipment hereunder, or the furnishing, performance, or use of any products or other goods sold hereto, whether due to a breach of contract, breach of warranty, the negligence of Graco, or otherwise.

FOR GRACO CANADA CUSTOMERS

The parties acknowledge that they have required that the present document, as well as all documents, notices and legal proceedings entered into, given or instituted pursuant hereto or relating directly or indirectly hereto, be drawn up in English. Les parties reconnaissent avoir convenu que la rédaction du présente document sera en Anglais, ainsi que tous documents, avis et procédures judiciaires exécutés, donnés ou intentés à la suite de ou en rapport, directement ou indirectement, avec les procédures concernées.

Graco Information

TO PLACE AN ORDER, contact your Graco distributor, or call one of the following numbers to identify the distributor closest to you:

1-800-328-0211 Toll Free

612-623-6921

612-378-3505 Fax

All written and visual data contained in this document reflects the latest product information available at the time of publication. Graco reserves the right to make changes at any time without notice.

MM 306494

Graco Headquarters: Minneapolis

International Offices: Belgium, China, Japan, Korea

GRACO INC. P.O. BOX 1441 MINNEAPOLIS, MN 55440-1441

www.graco.com

PRINTED IN USA 306494 March 1955 Revised August 2022