

Instructions – Parts List



President® Pump

WITH PRIMING PISTON

306746K

24:1 Ratio Models

4320 psi (29.8 MPa, 298 bar) Maximum Fluid Working Pressure

Part No. 205791, Series E

5 & 10 gallon (19 & 38 liter) Pail Size

Part No. 205792, Series E

55 gallon (200 liter) Drum Size

Part No. 206738, Series E

5 gallon (19 liter) Ram Size

48:1 Ratio Models

4800 psi (33.1 MPa, 331 bar) Maximum Fluid Working Pressure

Part No. 206597, Series F

5 & 10 gallon (19 & 38 liter) Pail Size

Part No. 206739, Series E

5 gallon (19 liter) Ram Size



Read warnings and instructions.
See page 2 Table of Contents.

! WARNING

Never exceed 100 psi (0.7 MPa, 7 bar) maximum air pressure to the 48:1 President pump. Do not exceed the maximum working pressure of any component or accessory used in the system.

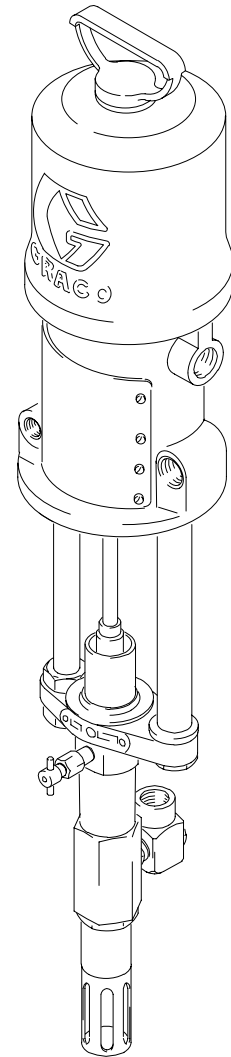

T11807A

Table of Contents

Warnings	2
Installation	5
Operation	8
Maintenance	10
Troubleshooting	11
Displacement Pump Service	12
Parts	14
Dimensions	16
Mounting Hole Layout	16
Technical Data	17
Graco Warranty	18
Graco Phone Numbers	18

Symbols

Warning Symbol



This symbol alerts you to the possibility of serious injury or death if you do not follow the instructions.

Caution Symbol



This symbol alerts you to the possibility of damage to or destruction of equipment if you do not follow the instructions.

! WARNING



INSTRUCTIONS

EQUIPMENT MISUSE HAZARD

Equipment misuse can cause the equipment to rupture or malfunction and result in serious injury.

- This equipment is for professional use only.
- Read all instruction manuals, tags, and labels before operating the equipment.
- Use the equipment only for its intended purpose. If you are not sure, call your Graco distributor.
- Do not alter or modify this equipment. Use only genuine Graco parts and accessories.
- Check equipment daily. Repair or replace worn or damaged parts immediately.
- Do not exceed the maximum working pressure of the lowest rated system component. Refer to the **Technical Data** on page 17 for the maximum working pressure of this equipment.
- Use fluids and solvents which are compatible with the equipment wetted parts. Refer to the **Technical Data** section of all equipment manuals. Read the fluid and solvent manufacturer's warnings.
- Do not use hoses to pull equipment.
- Route hoses away from traffic areas, sharp edges, moving parts, and hot surfaces. Do not expose Graco hoses to temperatures above 82°C (180°F) or below -40°C (-40°F).
- Wear hearing protection when operating this equipment.
- Do not lift pressurized equipment.
- Comply with all applicable local, state, and national fire, electrical, and safety regulations.

WARNING



FIRE AND EXPLOSION HAZARD

Improper grounding, poor ventilation, open flames or sparks can cause a hazardous condition and result in a fire or explosion and serious injury.

- Ground the equipment and the object being sprayed. Refer to **Grounding** on page 5.
- If there is any static sparking or you feel an electric shock while using this equipment, **stop spraying immediately**. Do not use the equipment until you identify and correct the problem.
- Provide fresh air ventilation to avoid the buildup of flammable fumes from solvents or the fluid being sprayed.
- Keep the spray area free of debris, including solvent, rags, and gasoline.
- Electrically disconnect all equipment in the spray area.
- Extinguish all open flames or pilot lights in the spray area.
- Do not smoke in the spray area.
- Do not turn on or off any light switch in the spray area while operating or if fumes are present.
- Do not operate a gasoline engine in the spray area.



INJECTION HAZARD

Fluid from the dispense gun, hose leaks, or ruptured components can inject fluid into your body and cause extremely serious injury, including the need for amputation. Splashing fluid in the eyes or on the skin can also cause serious injury.

- Fluid injected into the skin might look like just a cut, but it is a serious injury. **Get immediate medical attention**.
- Do not point the gun/valve at anyone or at any part of the body.
- Do not put your hand or fingers over the spray tip/nozzle.
- Do not stop or deflect fluid leaks with your hand, body, glove, or rag.
- If spraying, always have the trigger guard on the gun when dispensing.
- If the unit is equipped with a gun diffuser, check the gun diffuser operation weekly. Refer to the gun manual.
- Be sure the gun/valve trigger safety operates before dispensing.
- Lock the gun/valve trigger safety when you stop dispensing.
- Follow the **Pressure Relief Procedure** on page 8 if the nozzle clogs, and before cleaning, checking or servicing the equipment.
- Tighten all fluid connections before operating the equipment.
- Check the hoses, tubes, and couplings daily. Replace worn, damaged, or loose parts immediately. Do not repair high pressure couplings; you must replace the entire hose.

WARNING



TOXIC FLUID HAZARD

Hazardous fluid or toxic fumes can cause serious injury or death if splashed in the eyes or on the skin, inhaled, or swallowed.

- Know the specific hazards of the fluid you are using.
- Store hazardous fluid in an approved container. Dispose of hazardous fluid according to all local, state and national guidelines.
- Always wear protective eyewear, gloves, clothing and respirator as recommended by the fluid and solvent manufacturer.



MOVING PARTS HAZARD

Moving parts, such as the air motor piston, can pinch or amputate your fingers.

- Keep clear of all moving parts when starting or operating the pump.
- Keep your hands and fingers away from the priming piston and the fluid intake valve when the pump is charged with air.
- Before servicing the equipment, follow the **Pressure Relief Procedure** on page 8 to prevent the equipment from starting unexpectedly.

Installation



General Information

NOTE: Reference numbers and letters in parentheses in the text refer to the callouts in the figures and the parts drawing.

NOTE: Always use Genuine Graco Parts and Accessories, available from your Graco distributor. If you supply your own accessories, be sure they are adequately sized and pressure rated for your system.

Fig. 2 is only a guide for selecting and installing system components and accessories. Contact your Graco distributor for assistance in designing a system to suit your particular needs.

Grounding

 WARNING	
	FIRE AND EXPLOSION HAZARD Before operating the pump, ground the system as explained below. Also read the section FIRE AND EXPLOSION HAZARD on page 3.

1. *Pump:* To ground the pump, loosen the grounding lug locknut (A) and washer (B). Insert one end of a 12 gal (1.5 mm²) minimum ground wire (D) into the slot in lug (C) and tighten locknut securely. See Fig. 1. Connect the other end of the wire to a true earth ground. Check your local code.

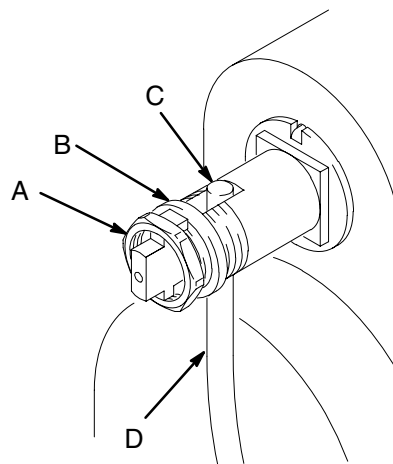

Fig. 1

T11809A

2. *Air and fluid hoses:* use only grounded hoses with a maximum of 500 ft (150 m) combined hose length to ensure grounding continuity.
3. *Air compressor:* follow manufacturer's recommendations.
4. *Spray gun or dispensing valve:* obtain grounding through connection to a properly grounded fluid hose and pump.
5. *Object being sprayed:* follow your local code.
6. *Solvent pails used when flushing:* follow your local code. Use only metal pails, which are conductive, placed on a grounded surface. Do not place the pail on a nonconductive surface, such as paper or cardboard, which interrupts the grounding continuity.
7. *To maintain grounding continuity when flushing or relieving pressure,* hold a metal part of the gun/valve firmly to the side of a grounded *metal* pail, then trigger the gun/valve.

Installation

Mounting the Pump

Mount the pump to suit the type of installation planned. The pump dimensions and mounting hole layout are shown on page 16.

System Accessories

Refer to the Installation drawing and the information on the following pages for assistance setting up your system.

NOTE: To ensure maximum pump performance, be sure that any accessory used is properly sized to meet your system's requirements.

Your system should include an air line filter (J) to remove harmful dirt and moisture from your compressed air supply. On the air line (E), each pump should have a bleed-type master air valve (G), an air regulator (F) and shutoff valve (O), and an air line oiler (K) which must be installed downstream from the air regulator. See Fig. 2.

WARNING

Two accessories, the bleed-type master air valve (G), and the fluid drain valve (R), are required for your system to reduce the risk of serious bodily injury from moving parts or injection when shutting off the pump.

The bleed-type air valve relieves trapped air between the valve and the pump, after the pump is shut off. Trapped air can cause the pump to cycle unexpectedly and result in serious bodily injury if you are adjusting or repairing the pump.

The fluid drain valve helps relieve fluid pressure in the displacement pump, hose, and gun/dispensing valve when shutting off the pump. Triggering the gun/dispensing valve to relieve pressure may not be sufficient, especially if there is a clog in the hose, gun/dispensing valve, and/or tip/nozzle.

Connecting the Hoses

Connect a grounded air supply hose (E) to the 1/2 npt(f) air inlet or the air regulator. Connect a grounded fluid dispensing hose (L) to the 1 in. npt fluid outlet, using a suitable adapter. For more flexible gun movement, use a shorter whip hose (grounded) (M) between the main fluid hose and the gun/valve.

Installation

KEY

E Air Supply Line
F Air Regulator
G Bleed-Type Master Air Valve
H Drain Valve

J Air Line Filter
K Air Line Oiler
L Fluid Hose

M Whip Hose
N Fluid Shutoff Valve
O Air Shutoff Valve

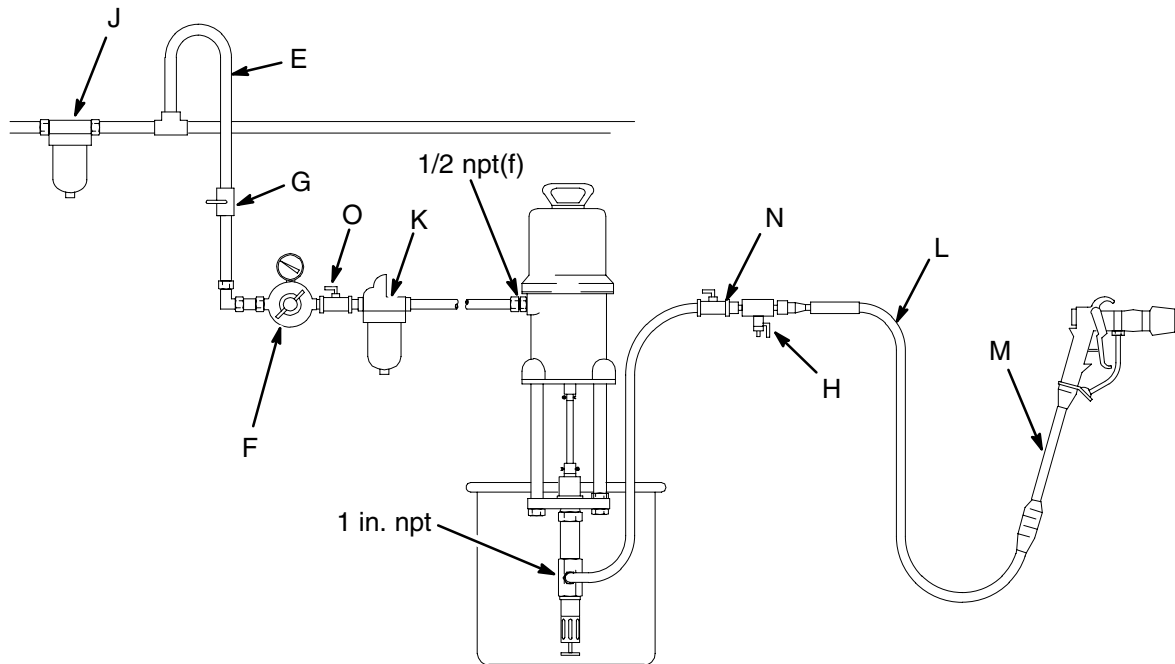

Fig. 2

T11808A

Operation

Pressure Relief Procedure

WARNING

FLUID INJECTION HAZARD

The system pressure must be manually relieved to prevent the system from starting or spraying accidentally. To reduce the risk of an injury from accidental spray from the gun, splashing fluid, or moving parts, follow the **Pressure Relief Procedure** whenever you:

- are instructed to relieve the pressure,
- stop spraying,
- check or service any of the system equipment,
- or install or clean the spray nozzle.

1. Shut off the air supply to the pump.
2. Close the bleed-type master air valve (required in your system).
3. Hold a metal part of the gun firmly to the side of a grounded metal pail, and trigger the gun to relieve pressure.
4. Open the drain valve (required in your system), having a container ready to catch the drainage.

5. Leave the drain valve open until you are ready to spray again.

*If you suspect that the spray nozzle or hose is completely clogged, or that pressure has not been fully relieved after following the steps above, **very slowly** loosen the nozzle retaining ring or hose end coupling and relieve pressure gradually, then loosen completely. Now clear the nozzle or hose.*

Flush Pump Before Using

Pumps are tested with lightweight oil which is left in to protect the pump parts. To prevent contamination of fluids, flush the pump with a compatible solvent before using. If the pump will supply a circulating system, circulate the solvent until the system is thoroughly flushed.

WARNING

Be sure your entire system is properly grounded before flushing. Refer to **Fire or Explosion Hazard** on page 3. Relieve pressure, remove the tip from the gun, then hold a metal part of the gun firmly to the side of a grounded metal pail, and use the lowest possible pressure to flush.

Operation

Starting and Adjusting the Pump

Fill the wet-cup (25) half full with Graco Throat Seal Liquid (TSL). With the drain valve and bleeder valve closed, and the gun/valve safety disengaged, trigger the gun/valve and slowly open the air supply valve until the pump starts. If fluid does not flow from triggered gun/valve, open the bleeder valve (12) slightly. See Fig. 3. When fluid appears, close bleeder valve.

WARNING

Keep your hand and fingers away from the priming piston and fluid intake valve (R) to reduce the risk of serious bodily injury, including amputation.

With the pump and lines primed, and with adequate air pressure and volume supplied, the pump will start and stop as the spray gun/valve is triggered and released. In a circulating system, it will run continuously and speed up or slow down as supply demands until air supply is shut off.

Use an adequately sized air regulator (F) to control pump speed and fluid pressure. See the **Installation** drawing on page 7. Always use the lowest pressure necessary to give you the results you want.

Never exceed the maximum air pressure to the pump (see **Technical Data** on page 17).

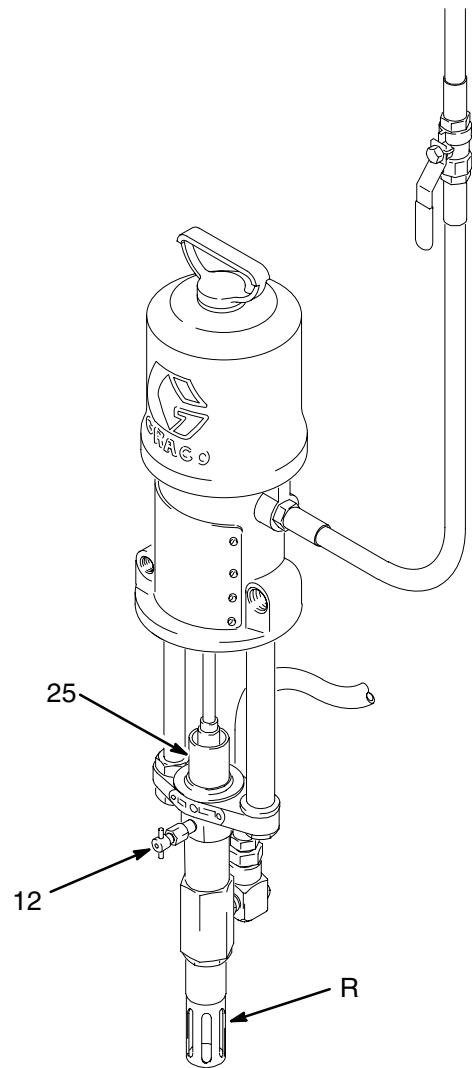

Fig. 3

TI1810A

Maintenance

WARNING

To reduce the risk of serious injury whenever you are instructed to relieve pressure, always follow the **Pressure Relief Procedure** on page 8.

Keep the wet-cup (25) filled with Graco Throat Seal Liquid (TSL). See Fig. 3. Check tightness of packing nut (36 or 60) weekly. The packing nut should be tight enough to prevent leakage, but no tighter. Follow the **Pressure Relief Procedure** on page 8 before adjusting the packing nut.

Never allow the pump to run dry of fluid being pumped. A dry pump will quickly accelerate to a high speed, possibly damaging itself. If your pump accelerates quickly, or is running too fast, stop it immediately and check the fluid supply. If the supply container is empty and air has been pumped into lines, prime pump and lines with fluid, or flush and leave filled with compatible solvent. Eliminate all air from fluid system.

For overnight shutdown, follow the **Pressure Relief Procedure** on page 8. Always stop the pump at the bottom of its stroke to keep fluid from drying on the exposed displacement rod. Always flush the pump before the fluid dries on the rod. If the pump is to be stored, and you are pumping water-based fluids, first flush with water, then with mineral spirits to protect the pump parts.

Troubleshooting

WARNING

To reduce the risk of serious injury whenever you are instructed to relieve pressure, always follow the **Pressure Relief Procedure** on page 8.

Before You Start

- To reduce downtime, be sure you have all necessary repair parts available. Recommended spare parts are listed in the **Parts List** on page 14 with an asterisk (*).
- Packing repair kits are available for both the 24:1 and 48:1 pumps (see **Parts List** on page 14). If you have a repair kit, use all the new parts for the best results. Parts included in the repair kits are marked with a double asterisk (e.g., 28**).
- Whenever you replace the packings, also replace the glands and bearing.
- When cleaning parts, use a compatible solvent. Inspect parts for wear or damage and replace as necessary. Scoring or irregular surfaces on the booster rod (35) or the displacement rod (33 or 59) causes premature packing wear and leaking. Check these parts by rubbing a finger on the surface or holding them up to the light at a slight angle.
- Use light, water-proof grease whenever grease is mentioned.
- Check all possible problems and solutions before disassembling pump.

Problem	Cause	Solution
Pump fails to operate.	Restricted line or inadequate air supply.	Clear; increase air supply.
	Obstructed fluid hose, gun, or dispensing valve.	Clear*.
	Exhausted fluid supply.	Refill and prime**.
	Fluid dried on displacement rod.	Clean***.
	Damaged air motor.	Service; see manual 306982.
Pump operates but output is low on both strokes.	Restricted line or inadequate air supply.	Clear; increase air supply.
	Obstructed fluid hose, gun, or dispensing valve.	Clear*.
	Exhausted fluid supply.	Refill and prime**.
	Open or worn bleeder valve.	Close; replace.
	Air in displacement pump and hose.	Reprime; use bleeder valve, inductor, or ram.
	Fluid too heavy for pump priming.	Use bleeder valve, inductor, or ram.
	Obstructed or worn intake or check valve.	Clear; service.
	Worn throat packings.	Replace.
Erratic or accelerated operation.	Exhausted fluid supply.	Refill and prime**.
	Obstructed or worn intake or check valve.	Clear; service.
	Connecting rods out of alignment.	Adjust.

*Follow the **Pressure Relief Procedure** on page 8. Disconnect the fluid hose. Turn on the air just enough to start the pump; if pump starts, the obstruction is in the fluid hose, gun, or valve.

** Stop pump immediately. Refill and prime to remove all air from system, or flush pump and store with mineral spirits in it.

***To help avoid this problem, always stop the pump at the bottom of its stroke, and keep TSL in wet-cup.

Displacement Pump Service

⚠ WARNING

To reduce the risk of serious injury whenever you are instructed to relieve pressure, always follow the **Pressure Relief Procedure** on page 8.

1. Solvent flush the fluid from the pump, if possible; then relieve the air and fluid pressures according to the **Pressure Relief Procedure** on page 8. Disconnect the hoses, remove the pump from its mounting, and clamp in a vise.

NOTE: Packing repair kits 207158 (for 24:1 pump) and 207159 (for 48:1 pump) are available. Use all the new parts, even if the old ones still look good, for the best results.

2. Unscrew the coupling nut (22) from the stud (24) and the stud from the displacement rod (33 or 59). Loosen the setscrews (40) in large locknuts (45) and remove the locknut from the large mounting tubes (P). See Fig. 4. If the mounting tubes are to be replaced, wrench the tubes close to the air motor base as shown in Fig. 4 to prevent thread damage.

3. Unscrew the booster cylinder (34 or 61) from the pump housing (11) and pull the booster rod (35), intake valve assembly, and displacement rod from the bottom of housing.
4. Unscrew the locknuts (44, 45), remove the priming piston (26 or 58) from the booster rod, and pull the intake valve from the booster rod. See Fig. 5. If the valve is seized in the housing, squirt penetrating oil around threads and gently tap around housing with a hammer to loosen.
5. Remove the wet-cup (25), unscrew the packing nut (36 or 60), and remove the o-ring (19), packings (31**, 32**, or 62**, 63**), and the backup (62**) from the throat cavity. See Fig. 5.
6. Clean and inspect all parts for wear or damage and replace as necessary.
7. Reassemble pump in reverse order of disassembly, making sure all parts are installed correctly, and that all threaded connections are tightened securely.

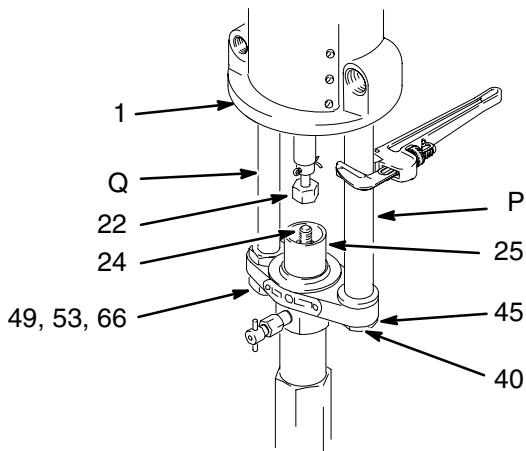

Fig. 4

TI1811A

Service

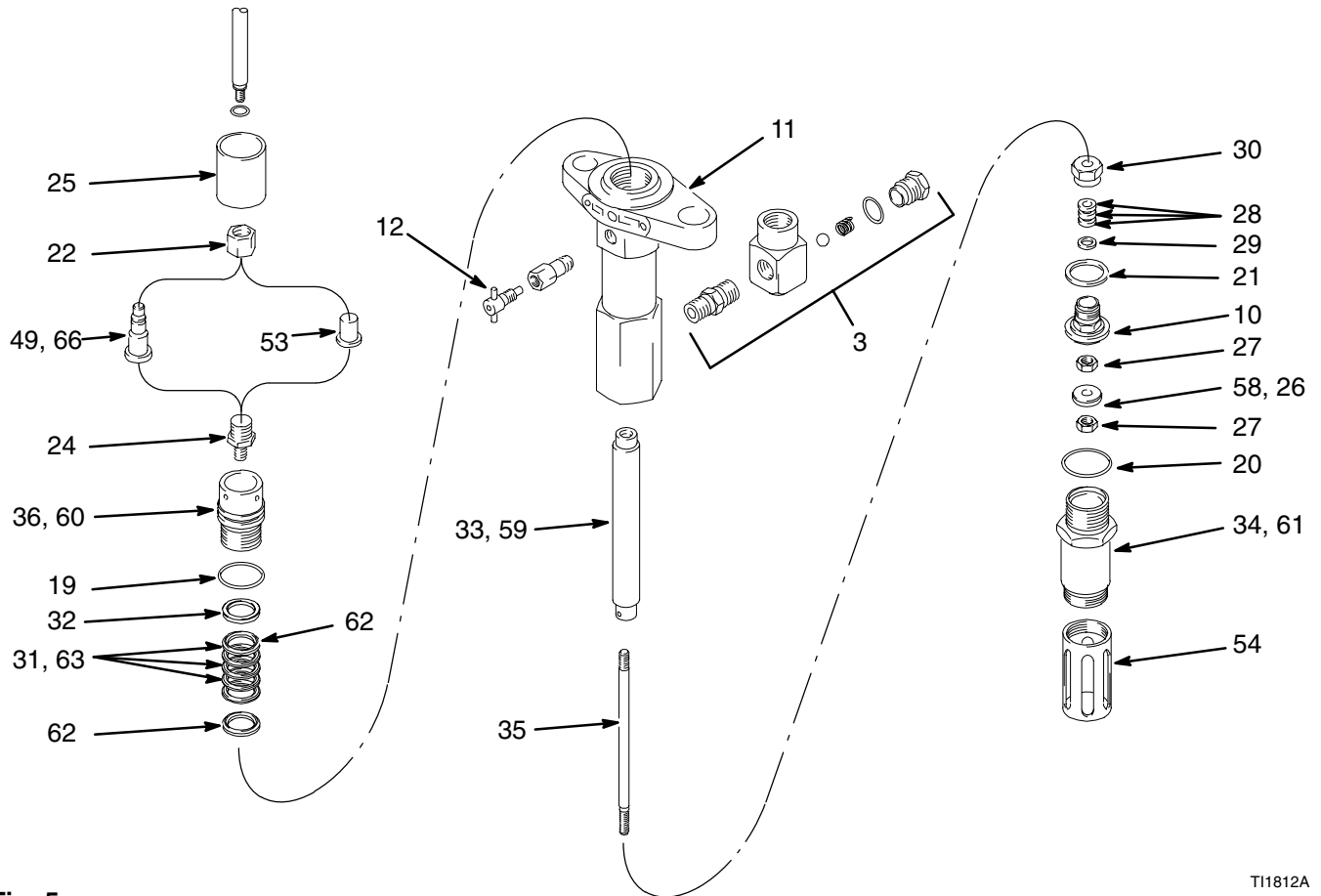

Fig. 5

T11812A

8. Turn the air motor upside down and place the fluid pump on the mounting tubes (P, Q). Leaving the coupling nut (22) loose, move the pump to align with the rods. Install and tighten the larger locknut (45) and lock in place with the setscrew (40). Being careful not to disturb the alignment, install and tighten the other locknut (44). Tighten the coupling nut securely. See Fig. 6.
9. If the grounding wire was disconnected before servicing, be sure to reconnect it before operating the pump.
10. Operate pump at a minimum air pressure (50 psi, 0.35 MPa, or 3.5 bar). Adjust small mounting tube (Q) locknuts (44) as necessary until pump runs smoothly at 15 psi (0.1 MPa, 1.05 bar).

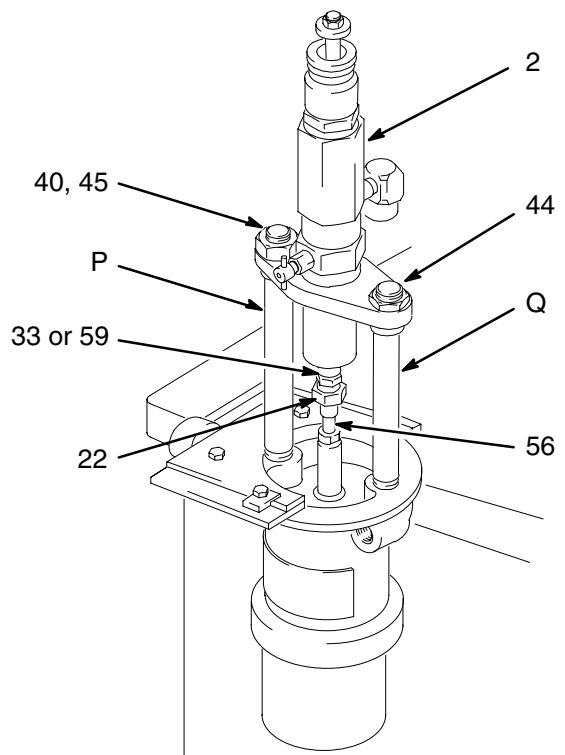

Fig. 6

T11813A

Parts

Model 205791, Series E

24:1 Ratio President Pump, 5 and 10 gal size

Includes items 1–49

Model 205792, Series E

24:1 Ratio President Pump, 55 gal size

Includes items 1–36, 40–46, and 51–56

Model 206738, Series E

24:1 Ratio President Pump, 5 gal size

Includes items 1–36, 40–46, and 64–66

Ref No.	Part No.	Description	Qty
1	205038	MOTOR, air, President See manual 306982 for parts	1
2	205831	PUMP, displacement; Series C; includes items 3–36	1
3	203916	.VALVE, check; includes items 4–9	1
4	203921	..SEAT	1
5*	101454	..BALL; steel; 5/8 in. diameter	1
6	151220	..SPRING, compression	1
7	160494	..HOUSING	1
8	160516	..O–RING; nitrile rubber	1
9	162289	..PLUG	1
10*	204926	..SEAL and SEAT, intake valve	1
11	215879	..HOUSING, fluid pump	1
12	206256	..VALVE, bleeder–type; includes items 13–15	1
13	102039	..ROLLPIN; 1/4 in. diameter; 1–1/2 in. long	1
14	165702	..BODY, valve	1
15	165703	..PLUG	1
17*	101579	..ROLLPIN; 1/8 in. diameter; 3/4 in. long	1
19	156593	..O–RING; nitrile rubber	1
20	156633	..O–RING; nitrile rubber	1
21	160158	..GASKET	1
22	160502	..NUT, coupling	1
24	162284	..STUD, coupling	1
25	162285	..WET–CUP	1
26	162287	..PISTON, priming	1
27	162288	..LOCKNUT, shovel–plate	2
28**	162301	..PACKING, flat; nitrile rubber	3
29**	162302	..BACKUP, packing; nylon	1
30	162303	..HOUSING, packing	1
31**	162308	..PACKING, flat; nitrile rubber	3
32**	162309	..BACKUP, packing; nylon	1
33	162311	..ROD, displacement	1
34	165133	..CYLINDER, booster	1
35	165134	..ROD, booster	1
36	165135	..NUT, packing	1
37	205833	TUBE, mounting; 1 in. diameter; 8–3/8 in. (213 mm) long	1

Model 206739, Series F

48:1 Ratio President Pump, 5 gal size

Includes items 1, 40–46, 57, and 64–66

Model 206597, Series F

48:1 Ratio President Pump, 5 and 10 gal size

Includes items 1, 37–49, and 57

Ref No.	Part No.	Description	Qty
38	206994	LUBRICANT, throat seal; 1 pint	1
41*	100579	PIN, cotter; 7/64 in. diameter; 1 in. long	1
42	162648	LOCKWASHER	2
44	160026	LOCKNUT, special; 3/4 garden hose thread	2
45	160505	LOCKNUT, special; 1–11 1/2 thread size	1
48	165137	TUBE, mounting; 3/4 in. diameter; 8–3/8 in. (213 mm) long	1
49	165138	ROD, connecting	1
51	205834	TUBE, mounting; 1 in. diameter; 19–3/4 in. (502 mm) long	1
52	156082	O–RING; nitrile rubber	2
53	160501	SOCKET, coupling	1
54	161310	TUBE, extension	1
55	165140	TUBE, mounting; 3/4 in. diameter; 19–3/4 in. (502 mm) long	1
56	165141	ROD, connecting; 13–7/8 in. (352 mm) long	1
57	206620	PUMP, displacement; Series C; includes items 3–25, 27–30, 35, 58–63	1
58	162294	..PISTON, priming	1
59	162316	..ROD, displacement	1
60	166393	..NUT, packing	1
61	166394	..CYLINDER, booster	1
62**	166395	..BACKUP, packing; nylon	2
63**	166396	..PACKING, flat; nitrile rubber	3
64	206737	TUBE, mounting; 1 in. diameter; 13–1/4 in. (337 mm) long	1
65	166546	TUBE, mounting; 3/4 in. diameter; 13–1/4 in. (337 mm) long	1
66	166547	ROD, connecting	1

* *Keep these spare parts on hand to reduce down time.*

** *These parts are included in Repair Kits 207158 and 207159.*

Parts

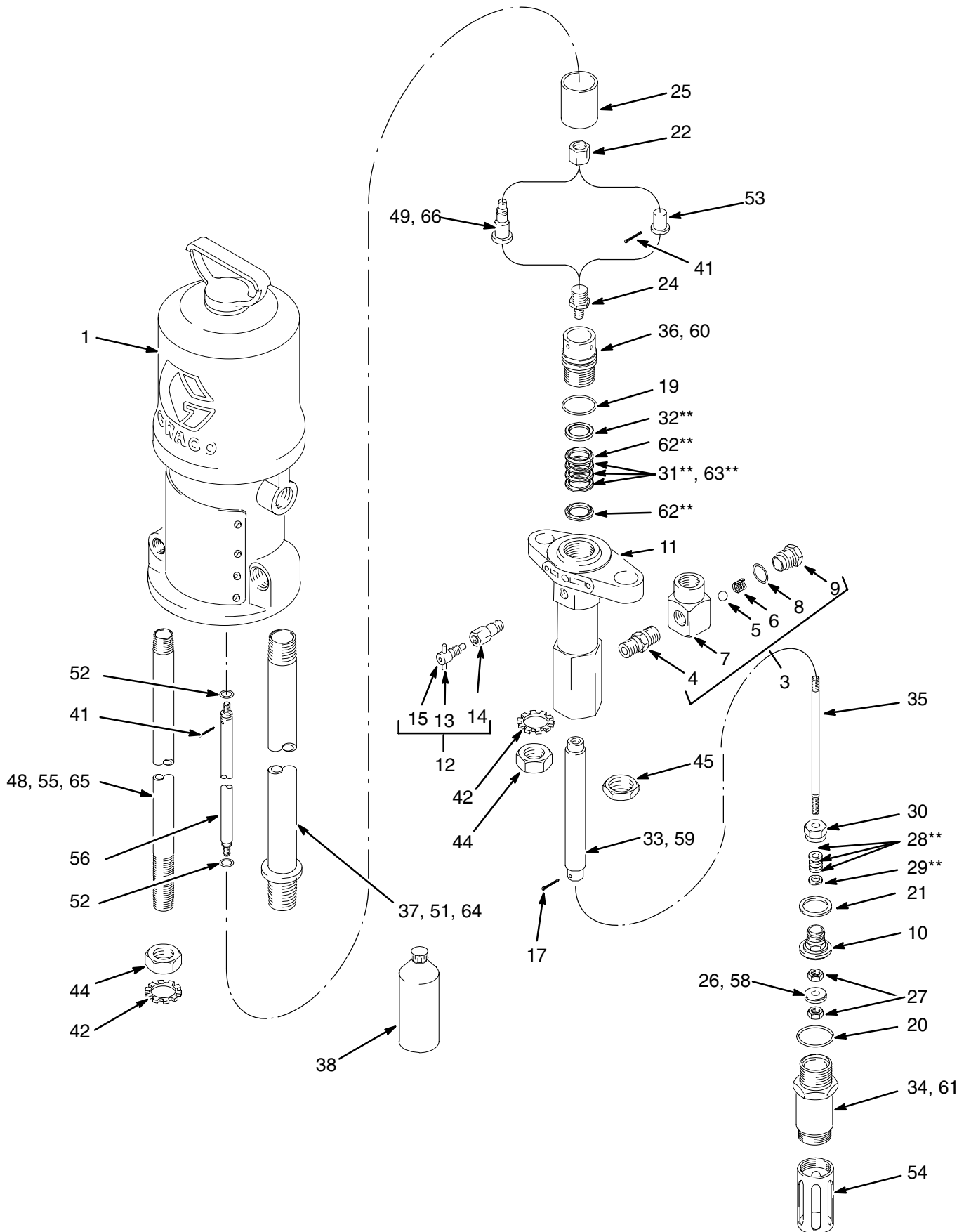

TI1814A

Dimensions

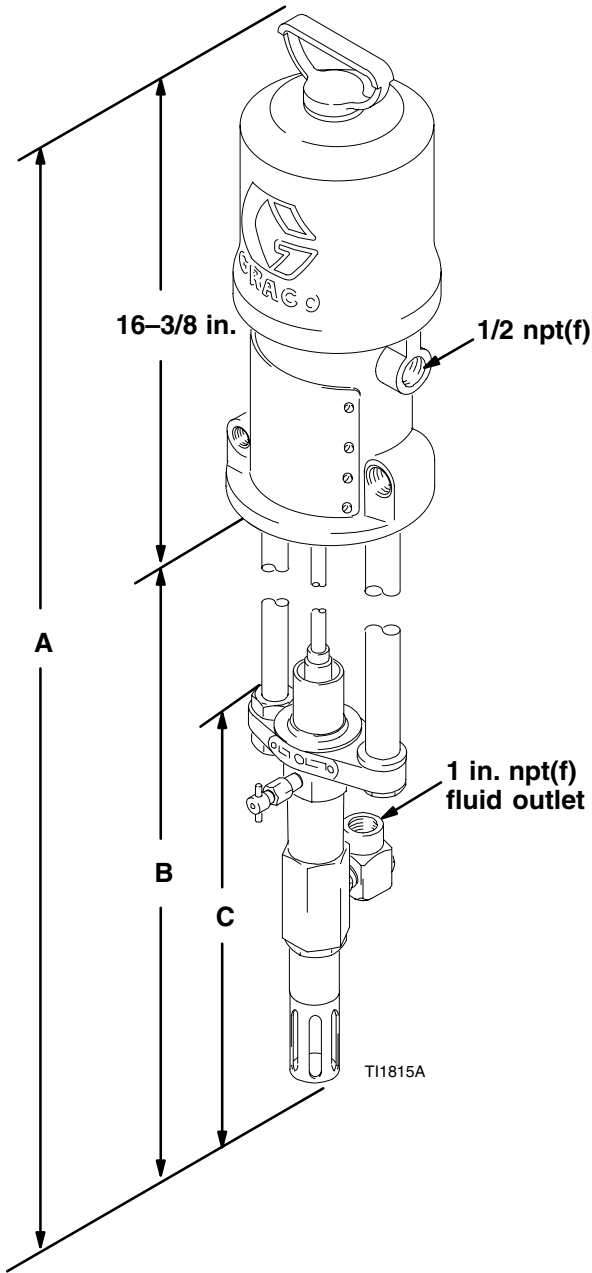

Model No.	A Overall Length	B Pump Length	C Fluid Pump
205791	36-5/8 in. (930 mm)	20-3/8 in. (518 mm)	14-3/8 in. (364 mm)
205792	48-3/4 in. (1238 mm)	32-1/2 in. (826 mm)	15-1/8 in. (384 mm)
206597	36-5/8 in. (930 mm)	20-3/8 in. (518 mm)	14-3/8 in. (364 mm)
206738	41-1/2 in. (1054 mm)	25-11/32 in. (644 mm)	14-3/8 in. (364 mm)
206739	41-1/2 in. (1054 mm)	25-11/32 in. (644 mm)	14-3/8 in. (364 mm)

Mounting Hole Layout

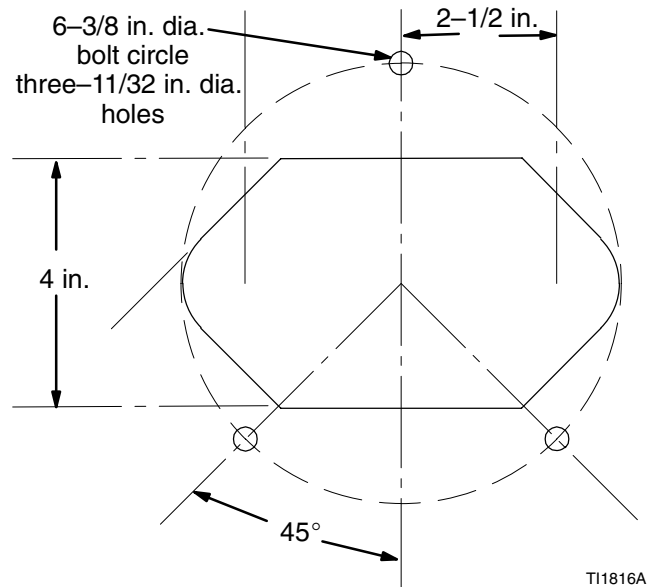

NOTE: Use 161822 Gasket.

Technical Data

Category	Data
Maximum working pressure	24:1 pump: 4320 psi (29.8 MPa, 298 bar) 48:1 pump: 4800 psi (33.1 MPa, 331 bar)
Recommended air operating range	24:1 pump: 40–180 psi (0.28–1.24 MPa, 2.8–12.4 bar) 48:1 pump: 40–100 psi (0.28–0.7 MPa, 2.8–7 bar)
Air consumption	24:1 pump: approx. 20 cfm (0.56 m ³ /min) at 1/2 gpm (1.95 liter/min) at 70 psi (0.48 MPa, 4.8 bar) 48:1 pump: approx. 29 cfm (0.82 m ³ /min) at 1/4 gpm (0.95 liter/min) at 70 psi (0.48 MPa, 4.8 bar)
Pump cycles per gallon (liter)	24:1 pump: 110 (418) 48:1 pump: 220 (836)
Recommended maximum pump delivery	24:1 pump: 1/2 gpm (19 liter/min) 48:1 pump: 1/4 gpm (0.95 liter/min)
Wetted parts	Nitralloy, Steel, Copper, Nitrile Rubber
Air inlet	1/2 npt(f)
Fluid outlet	1 in. npt(f)
Fluid inlet	Priming piston
Weight	45 lb (20 kg) approximate

Graco Standard Warranty

Graco warrants all equipment manufactured by Graco and bearing its name to be free from defects in material and workmanship on the date of sale by an authorized Graco distributor to the original purchaser for use. With the exception of any special, extended, or limited warranty published by Graco, Graco will, for a period of twelve months from the date of sale, repair or replace any part of the equipment determined by Graco to be defective. This warranty applies only when the equipment is installed, operated and maintained in accordance with Graco's written recommendations.

This warranty does not cover, and Graco shall not be liable for general wear and tear, or any malfunction, damage or wear caused by faulty installation, misapplication, abrasion, corrosion, inadequate or improper maintenance, negligence, accident, tampering, or substitution of non-Graco component parts. Nor shall Graco be liable for malfunction, damage or wear caused by the incompatibility of Graco equipment with structures, accessories, equipment or materials not supplied by Graco, or the improper design, manufacture, installation, operation or maintenance of structures, accessories, equipment or materials not supplied by Graco.

This warranty is conditioned upon the prepaid return of the equipment claimed to be defective to an authorized Graco distributor for verification of the claimed defect. If the claimed defect is verified, Graco will repair or replace free of charge any defective parts. The equipment will be returned to the original purchaser transportation prepaid. If inspection of the equipment does not disclose any defect in material or workmanship, repairs will be made at a reasonable charge, which charges may include the costs of parts, labor, and transportation.

THIS WARRANTY IS EXCLUSIVE, AND IS IN LIEU OF ANY OTHER WARRANTIES, EXPRESS OR IMPLIED, INCLUDING BUT NOT LIMITED TO WARRANTY OF MERCHANTABILITY OR WARRANTY OF FITNESS FOR A PARTICULAR PURPOSE.

Graco's sole obligation and buyer's sole remedy for any breach of warranty shall be as set forth above. The buyer agrees that no other remedy (including, but not limited to, incidental or consequential damages for lost profits, lost sales, injury to person or property, or any other incidental or consequential loss) shall be available. Any action for breach of warranty must be brought within two (2) years of the date of sale.

Graco makes no warranty, and disclaims all implied warranties of merchantability and fitness for a particular purpose in connection with accessories, equipment, materials or components sold but not manufactured by Graco. These items sold, but not manufactured by Graco (such as electric motors, switches, hose, etc.), are subject to the warranty, if any, of their manufacturer. Graco will provide purchaser with reasonable assistance in making any claim for breach of these warranties.

In no event will Graco be liable for indirect, incidental, special or consequential damages resulting from Graco supplying equipment hereunder, or the furnishing, performance, or use of any products or other goods sold hereto, whether due to a breach of contract, breach of warranty, the negligence of Graco, or otherwise.

FOR GRACO CANADA CUSTOMERS

The parties acknowledge that they have required that the present document, as well as all documents, notices and legal proceedings entered into, given or instituted pursuant hereto or relating directly or indirectly hereto, be drawn up in English. Les parties reconnaissent avoir convenu que la rédaction du présente document sera en Anglais, ainsi que tous documents, avis et procédures judiciaires exécutés, donnés ou intentés à la suite de ou en rapport, directement ou indirectement, avec les procédures concernées.

Graco Phone Numbers

TO PLACE AN ORDER, contact your Graco distributor, or call one of the following numbers to identify the distributor closest to you:

1-800-367-4023 Toll Free

612-623-6921

612-378-3505 Fax

Sales Offices: Minneapolis, Detroit

International Offices: Belgium, Korea, Hong Kong, Japan

GRACO INC. P.O. BOX 1441 MINNEAPOLIS, MN 55440-1441

www.graco.com

PRINTED IN U.S.A. 306746 10/1989 Revised 12/2001