

# Instructions – Parts List



STAINLESS STEEL

## 5:1 Ratio Bulldog® Pumps 306818J

500 psi (3.5 MPa, 35 bar) Maximum Working Pressure

**55 Gallon (200 liter) Size**  
**Part No. 207321, Series G**  
Rubber Packed

**Stubby Size**  
**Part No. 206418, Series D**  
Rubber Packed  
**Part No. 206796, Series D**  
PTFE Packed

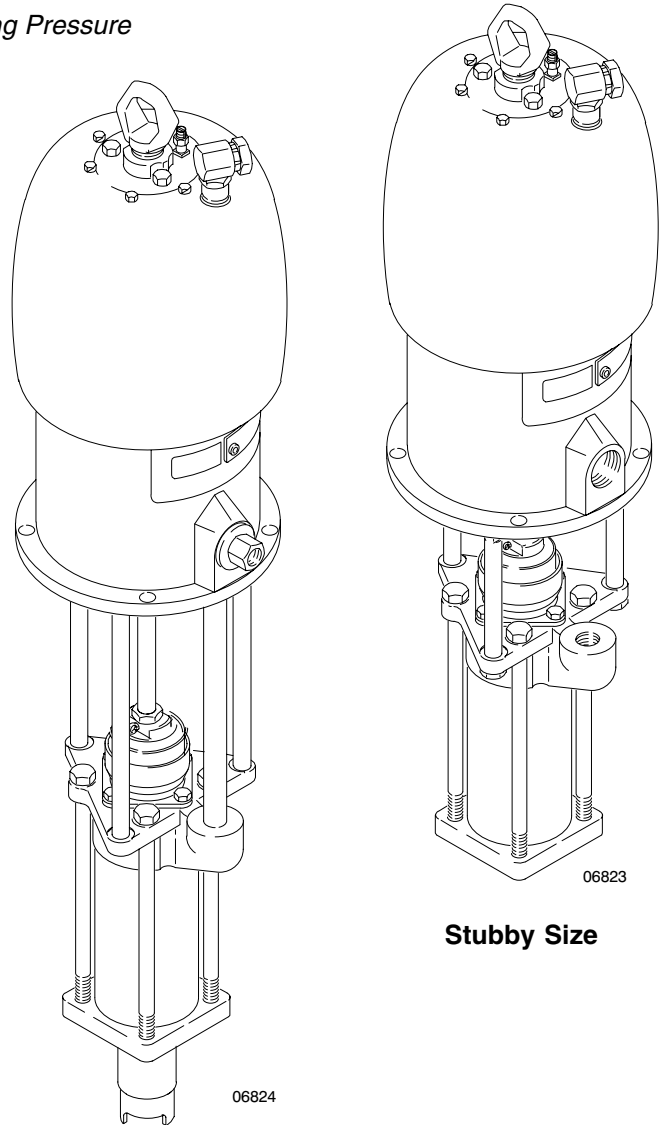

55 Gallon (200 liter) Size

Stubby Size



**Read warnings and instructions.**  
See page 2 for Table of Contents.

PROVEN QUALITY. LEADING TECHNOLOGY.

GRACO INC. P.O. BOX 1441 MINNEAPOLIS, MN 55440-1441  
Copyright 2002, Graco Inc. is registered to I.S. EN ISO 9001



# Table of Contents

Warnings .....	2
Installation .....	4
Operation .....	6
Maintenance .....	7
Troubleshooting .....	9
Service .....	10
Parts .....	14
Technical Data .....	18
Mounting Hole Layout .....	18
Dimensions .....	19
Graco Standard Warranty .....	20
Graco Information .....	20

# Symbols

## Warning Symbol



This symbol alerts you to the possibility of serious injury or death if you do not follow the instructions.

## Caution Symbol



This symbol alerts you to the possibility of damage to or destruction of equipment if you do not follow the corresponding instructions.

# ! WARNING



## EQUIPMENT MISUSE HAZARD

Equipment misuse can cause the equipment to rupture, malfunction, or start unexpectedly and result in a serious injury.

- This equipment is for professional use only.
- Read all the instruction manuals, tags, and labels before operating the equipment.
- Use the equipment only for its intended purpose. If you are uncertain about usage, call your Graco distributor.
- Do not alter or modify this equipment. Use only genuine Graco parts and accessories.
- Check the equipment daily. Repair or replace worn or damaged parts immediately.
- Do not exceed the maximum working pressure of the lowest rated system component.
- Use fluids that are compatible with the equipment wetted parts. See the **Technical Data** section of all the equipment manuals. Read the fluid manufacturer's warnings.
- Route the hoses away from traffic areas, sharp edges, moving parts, and hot surfaces. Do not expose Graco hoses to temperatures above 180°F (82°C) or below -40°F (-40°C).
- Do not use hoses to pull equipment.
- Do not lift pressurized equipment.
- Wear hearing protection when operating this equipment.
- Comply with all applicable local, state, and national fire, electrical, and other safety regulations.



## TOXIC FLUID HAZARD

Hazardous fluids or toxic fumes can cause a serious injury or death if splashed in the eyes or on the skin, swallowed, or inhaled.

- Know the specific hazards of the fluid you are using. Read the fluid manufacturer's warnings.
- Store hazardous fluid in an approved container. Dispose of the hazardous fluid according to all local, state, and national guidelines.
- Wear appropriate protective clothing, gloves, eyewear, and respirator.

# ⚠ WARNING



## FIRE AND EXPLOSION HAZARD

Improper grounding, poor air ventilation, open flames, or sparks can cause a hazardous condition and result in fire or explosion and serious injury.

- Ground the equipment and the object being sprayed. See **Ground the System** on page 4.
- Provide fresh air ventilation to avoid the buildup of flammable fumes from solvent or the fluid being sprayed.
- Extinguish all the open flames or pilot lights in the spray area.
- Electrically disconnect all the equipment in the spray area.
- Keep the spray area free of debris, including solvent, rags, and gasoline.
- Do not turn on or off any light switch in the spray area while operating or if fumes are present.
- Do not smoke in the spray area.
- Do not operate a gasoline engine in the spray area.
- If there is any static sparking while using the equipment, **stop spraying immediately**. Identify and correct the problem.



## PRESSURIZED EQUIPMENT HAZARD

Spray from the gun, hose leaks, or ruptured components can splash fluid in the eyes or on the skin and cause serious injury.

- Do not stop or deflect fluid leaks with your hand, body, glove, or rag.
- Follow the **Pressure Relief Procedure** on page 6 whenever you: are instructed to relieve the pressure; stop spraying; clean, check, or service the equipment; and install or clean the fluid nozzle.
- Tighten all the fluid connections before operating the equipment.
- Check the hoses, tubes, and couplings daily. Replace worn, damaged, or loose parts immediately. Permanently coupled hoses cannot be repaired; replace the entire hose.



## MOVING PARTS HAZARD

Moving parts, such as the air motor piston, can pinch or amputate fingers.

- Do not operate the equipment with the air motor shield removed.
- Keep clear of any moving parts when starting or operating the equipment.

# Installation

## Ground the System

In low pressure air spray systems, static sparking is generally not a problem; however, some simple precautions should be taken to reduce the risk. Check your local code for detailed grounding instructions for your area and type of equipment, and ground all of this equipment.

- *Pump:* loosen the grounding lug locknut (W) and washer (X). Insert one end of a 12 ga. (1.5 mm<sup>2</sup>) minimum ground wire (Y) into the slot in the lug (Z) and tighten the locknut securely. See Fig. 1 . Connect the other end of the wire to a true earth ground. Order Part No. 237569 Grounding Wire and Clamp.
- *Air compressor:* according to manufacturer's recommendations.
- *Object being sprayed:* according to local code.
- *Fluid supply container:* according to local code.
- *All solvent pails used when flushing,* according to local codes. Use only metal pails, which are conductive. Do not place the pail on a non-conductive surface, such as paper or cardboard, which interrupts the grounding continuity.

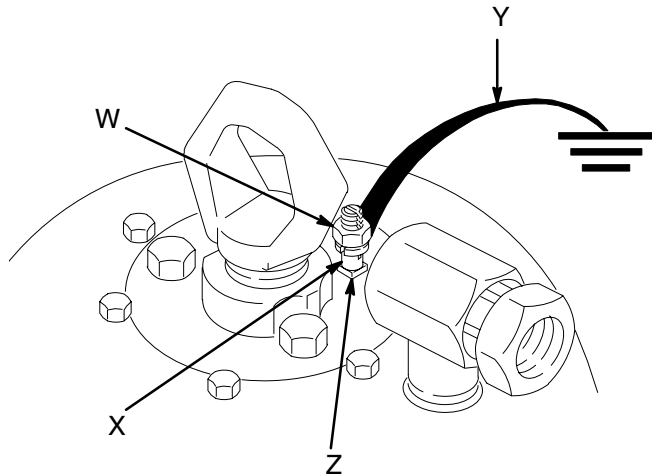
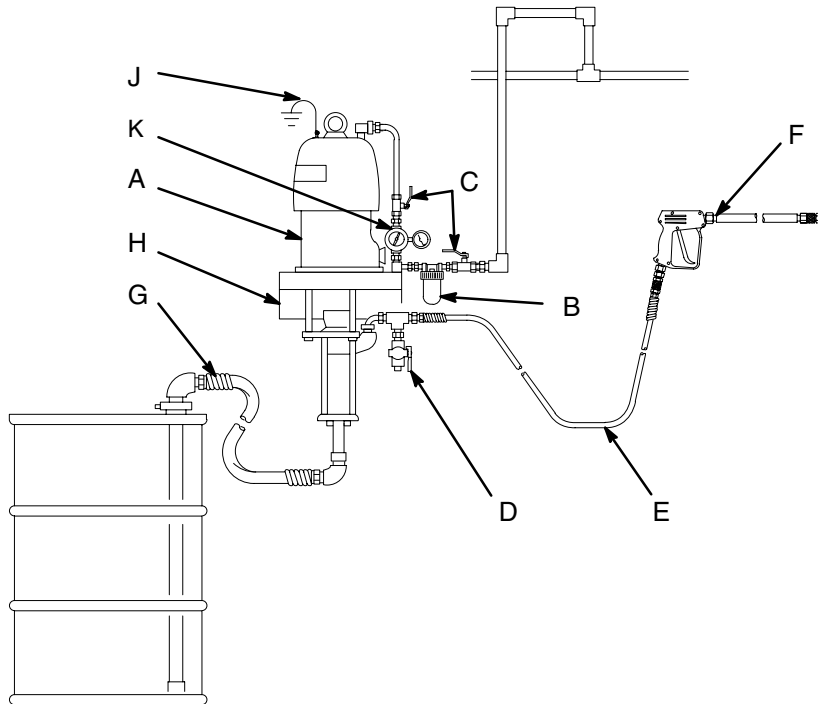

Fig. 1

06825

# Installation

## Typical Installation



### KEY

- A Pump
- B Air Line Filter
- C Bleed-Type Master Air Valve
- D Fluid Drain Valve
- E Fluid Supply Hose
- F Hydra-Clean Spray Gun
- G Fluid Suction Hose
- H Wall Bracket
- J Ground Wire
- K Air Regulator

7442A

**NOTE:** Reference numbers and letters in parentheses in the text refer to the callouts in the Figures and Parts Drawing.

The typical installation shown above is only a guide to selecting and installing required and optional accessories. For assistance in designing a system to suit your needs, contact your Graco distributor.

Mount the pump to suit the type of installation planned. The pump mounting hole layout and dimensions are shown on pages 18 and 19.

Connect a fluid suction hose (G) to the 2 in. npt(f) intake of the pump if it is not immersed.

Next, install a bleed-type master air valve (C) to relieve air trapped between the valve and the pump, an air regulator (K) to control pump speed, an air filter (B) to remove harmful dirt and moisture from the compressed air supply, and another bleed-type air valve to isolate the accessories for servicing.

On the fluid supply line, install a fluid drain valve (D) to assist in relieving pressure.

Be sure all air and fluid accessories are properly sized for your system, and are compatible with the fluid you are pumping.

## WARNING

A bleed-type master air valve (C) and a fluid drain valve (D) are required in your system. These accessories help reduce the risk of serious injury, including fluid injection and splashing of fluid in the eyes or on the skin, and injury from moving parts if you are adjusting or repairing the pump.

The bleed-type master air valve relieves air trapped between this valve and the pump after the air is shut off. Trapped air can cause the pump to cycle unexpectedly. Locate the valve close to the pump.

The fluid drain valve assists in relieving fluid pressure in the displacement pump, hose, and gun. Triggering the gun to relieve pressure may not be sufficient.

# Operation

## Pressure Relief Procedure

### WARNING

#### PRESSURIZED EQUIPMENT HAZARD

The system pressure must be manually relieved to prevent the system from starting or spraying accidentally. To reduce the risk of an injury from accidental spray from the gun, splashing fluid, or moving parts, follow the **Pressure Relief Procedure** whenever you:

- are instructed to relieve the pressure,
- stop spraying,
- check or service any of the system equipment,
- or install or clean the spray nozzle.

1. Close the pump air regulator.
2. Close the bleed-type master air valve (required in your system).
3. Hold a metal part of the gun firmly to a grounded metal waste container and trigger the gun to relieve fluid pressure.
4. Open the pump drain valve (required in your system), having a container ready to catch the drainage.

*If you suspect that the spray tip or hose is completely clogged, or that pressure has not been fully relieved after following the steps above, very slowly loosen the tip guard retaining nut or hose end coupling and relieve pressure gradually, then loosen completely. Now clear the tip or hose.*

## Using the Pump

### WARNING

To reduce the risk of serious injury whenever you are instructed to relieve pressure, always follow the **Pressure Relief Procedure** at left.

### WARNING

To reduce the risk of serious injury, including fluid injection and splashing in the eyes or on the skin, and property damage, never exceed the maximum air and fluid working pressure of the lowest rated component in your system.

The pump was tested in oil, and some oil was left in the pump. If the oil will contaminate the fluid you are pumping, flush it out.

Fill the packing nut/wet cup 1/2 full with Graco Throat Seal Liquid or a compatible solvent. Keep the cup filled at all times to help prevent the fluid you are pumping from drying on the displacement rod and damaging the throat packings.

To start the pump, turn on the main air supply. Open the bleed-type master air valve (A). Trigger the spray gun into a grounded metal pail, holding the gun firmly to the pail. Slowly open the air regulator until the pump is running smoothly (about 40 psi [280 kPa, 2.8 bar]). Operate the pump until all air is purged from the system. Release the gun trigger and lock the trigger safety.

Use the air regulator (F) to control fluid pressure and pump speed. Always use the lowest possible pressure and cycle rate to achieve the desired results. Higher pressures cause premature pump wear and gun wear, and usually do not improve the spray pattern.

In a direct supply system, with adequate air pressure supplied to the motor, the pump starts when the gun or dispensing valve is opened, and stalls against pressure when it is closed. In a circulating system, the pump will run continuously and speed up or slow down as the system demands.

If the pump accelerates quickly or is running too fast, stop it immediately. Check the fluid supply and refill it if necessary. Prime the pump to remove all air from the system, or flush the pump, **relieve the pressure**, but leave the system filled with a compatible solvent.

**NOTE:** A pump runaway valve (D) installed on the air line automatically shuts off the pump if it starts to run too fast.

# Maintenance

## Shutdown and Care of the Pump

Always stop the pump at the bottom of its stroke to prevent fluid from drying on the rod and damaging the throat packings.

### WARNING

To reduce the risk of serious injury whenever you are instructed to relieve pressure, always follow the **Pressure Relief Procedure** on page 6.

Check the tightness of the packing retainer screws (7) weekly. The screws should be tight enough to stop leakage, but no tighter. Always **relieve the pressure** before adjusting the packing retainer screws. See Fig. 2.

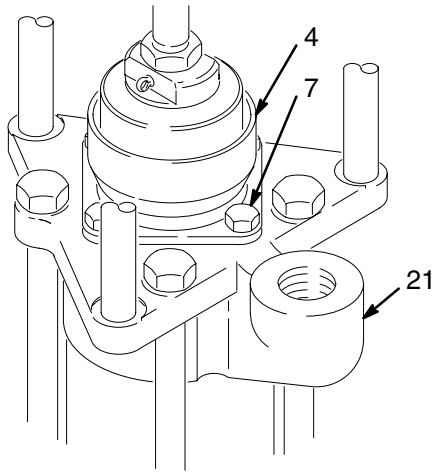

Fig. 2

06827

## Flushing

If you are pumping fluid which dries, hardens, or sets up, flush the system with a compatible solvent as often as necessary to prevent build up of dried fluid in the pump or hoses.

### WARNING

To reduce the risk of serious injury whenever you are instructed to relieve pressure, always follow the **Pressure Relief Procedure** on page 6.

To reduce the risk of static sparking or splashing in the eyes or on the skin, **relieve the pressure** and remove the spray tip before flushing. Start the pump. Hold a metal part of the gun/valve firmly to the side of a grounded metal pail and use the lowest possible fluid pressure during flushing. When flushing is complete, **relieve the pressure** again.

## Lubrication

### WARNING

To reduce the risk of serious injury whenever you are instructed to relieve pressure, always follow the **Pressure Relief Procedure** on page 6.

The accessory air line lubricator (G) provides automatic air motor lubrication. For daily, manual lubrication, **relieve the pressure**, disconnect the regulator, place about 15 drops of light machine oil in the pump air inlet, reconnect the regulator and turn on the air supply to blow oil into the motor.





# Troubleshooting

## WARNING

To reduce the risk of serious injury whenever you are instructed to relieve pressure, always follow the **Pressure Relief Procedure** on page 6.

Before servicing this equipment always make sure to **relieve the pressure**.

**Note:** Check all possible causes and solutions before disassembling the pump.

## WARNING

Never operate the pump with the air motor shield removed. Moving parts can pinch or amputate your fingers or other body parts. When the pump is operating, the air motor piston (located behind the air motor shield) moves.

Problem	Cause	Solution
Pump does not operate, or no fluid flow.	Loose or broken pump parts.	Disassemble, check, repair.
	Restricted line or inadequate air supply.	Clear, increase.
	Exhausted fluid supply.	Refill and prime.
	Clogged fluid hoses.	Clean, or replace.
	Damaged air motor.	Repair; See manual 307049 for Air Motor Model 208356.
Pump operates, but output is low.	Insufficient air supply.	Increase.
	Exhausted fluid supply.	Refill and prime.
	Obstructed gun or dispensing valve.	Clear.
	Packing retainer needs adjustment.	Loosen or tighten screws as necessary.
	Damaged fluid pump packings.	Replace.
	Held open or worn piston or intake valve.	Repair. See page 10.
Erratic or accelerated operation.	Exhausted fluid supply.	Refill and prime.
	Fluid intake or piston valve worn.	Repair. See page 10.

# Service

## Before you start:

- Have all the necessary repair parts on hand. Recommended spare parts are shown in the parts list, for example (32†).
- A packing repair kit is available for each pump. Use Kit No. 206931 for rubber packed pumps, and 207349 for PTFE packed pumps. Use all the new parts in the kit for the best results. Kit parts are indicated with an asterisk, for example, (17\*).
- Always replace the glands when replacing the packings, whether or not you use a repair kit.
- Use a compatible solvent to clean parts. Inspect parts for wear or damage and replace parts as needed. Scoring or irregular surfaces of the displacement rod or polished inner wall of the cylinder causes premature packing wear and leaking. Check these parts by rubbing a finger on the surface and by holding the parts up to the light at a slight angle.
- Use light, water-proof grease wherever lubrication is indicated.

## Disassembly

### **WARNING**

To reduce the risk of serious injury whenever you are instructed to relieve pressure, always follow the **Pressure Relief Procedure** on page 6.

1. Flush the pump, if possible. Then **relieve the pressure**. Disconnect all air and fluid hoses. Remove the pump from its mounting and place it upright in a vise by clamping the intake valve housing (20).
2. Remove the tie rod locknuts (29), the cotter pin (28) and the coupling nut (38). If the riser tube (50) is installed, remove the outlet adapter (48). Remove the intake tube (51, if used). Pull the pump away from the motor.
3. Remove the screws (7) from the packing retainer (4). Remove the packing retainer.
4. Screw the tie bolts (6) out of the intake housing (20).
5. Pull the outlet housing (21) off the cylinder (19).
6. Remove the bearing (10), female gland (14), v-packings (24 & 25, or 44), and male gland (13) from the outlet housing (21).
7. Remove the displacement rod (3) from the cylinder (19). Remove the cylinder. Inspect the outer surface of the displacement rod and the inner surface of the cylinder for scoring or damage.
8. Remove the intake valve housing (20) from the vise. Remove the pin (8), plate (18), and o-ring (23 or 43). Inspect the seat (16) in place.
9. Place the displacement rod assembly in a vise, holding it by the flats. Use a 2-1/2 in. hex wrench to remove the valve seat (15). Remove the bearing (11), packing (12), plate (17) and o-ring (22 or 42). If the rod needs replacing, remove one cotter pin (5) and pull the stop pin (9) out.
10. Clean all parts thoroughly, replace worn or damaged parts. Lubricate all parts before reassembling.

# Service

## Reassembly

1. One at a time, install the following parts in the outlet housing (21): the male gland (13\*), four rubber v-packings (24\*) and one plastic v-packing (25\*), **or** five PTFE v-packings (44\*) installed so the lips of the v-packings face down in the throat, the female gland (14\*), and the bearing (10\*). Maintain a 0.02–0.05 in. (0.508–1.27 mm) gap in the bearing seam. Install the packing retainer (4) and loosely install the screws (7).
2. Place the displacement rod (3) in a vise, holding it by the flats.
  - a. Install the stop pin (9) into the displacement rod (3) and secure with the cotter pins (5).
  - b. Place the packing (12\* or 41\*) and bearing (11) on the displacement rod.
  - c. Install the valve plate (17\*) into the displacement rod (3).
  - d. Place the o-ring (22\*) or (42\*) onto the valve seat (15).
  - e. Use a 2–1/2 in. hex wrench to install the valve seat (15) into the displacement rod (3).
  - f. Remove the displacement rod assembly from the vise and set it aside.
3. Place the intake valve housing (20) in a vise.
  - a. Place the o-ring (23\* or 43\*) around the intake valve housing (20).
  - b. Install the valve plate (18\*) rounded side up.
  - c. Install the pin (8) in the housing (20).
  - d. Leave the intake valve housing (20) in the vise.
4. Place the cylinder (19) on the intake valve housing (20).
5. Lubricate the displacement rod assembly and slid it into the cylinder (19).
6. Place the o-ring (23\* or 43\*) on the outlet housing (21). Set the outlet housing onto the cylinder (19), aligning the 4 holes in the housing with the holes in the intake housing (20).
7. Place the packing retainer (4) onto the cylinder.
8. Install the tie bolts (6) through the outlet housing (21). Torque the bolts to 57–64 ft-lb (77–85 N•m).
9. Screw the jam nut (30) all the way up the threads of the connecting rod (36 or 47). Screw the connecting rod into the displacement rod until it stops. Back off the connecting rod until the pin holes align, and install the pin (28). Screw the jam nut down tightly.
10. Align the outlet housing with the tie rods (35 or 46) and riser tube (50, if used). Tighten the coupling nut (38) firmly onto the air motor piston rod. Install and tighten the tie rod locknuts (29).
11. Apply low pressure air to the motor and check to see that the tie bolts (6) are not binding and the pump runs smoothly on 15 psi (100 kPa, 1 bar) or less air pressure. Adjust the bolts as necessary.
12. Tighten the packing retainer screws (7) just enough to stop leakage, but no tighter. Reinstall the outlet adapter (48, if used) and intake tube (51, if used).
13. Remount the pump and connect the ground wire.

# Service

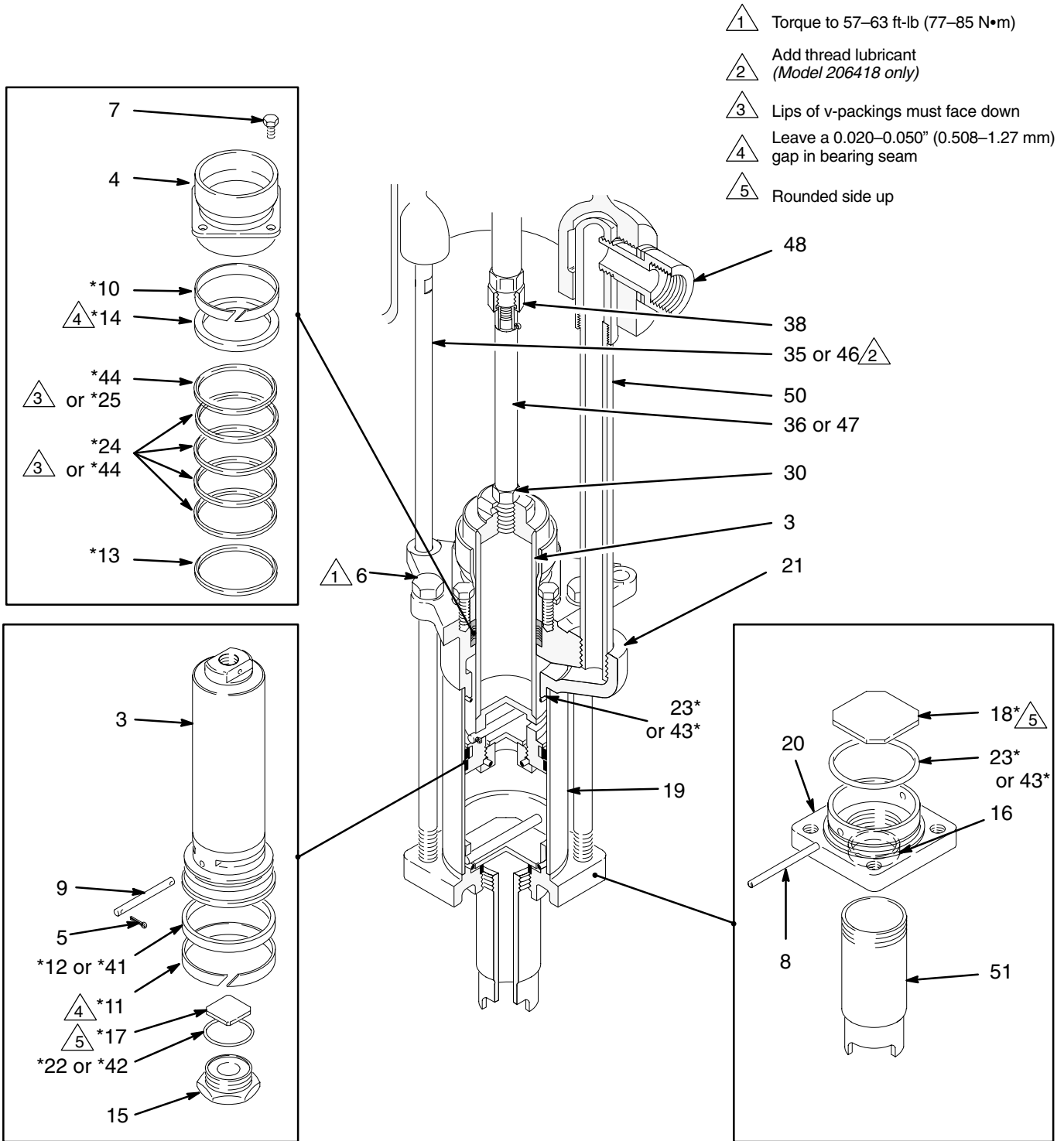

Fig. 3

06828



# Parts

Rubber-Packed Pumps  
 Models 207321 and 206418

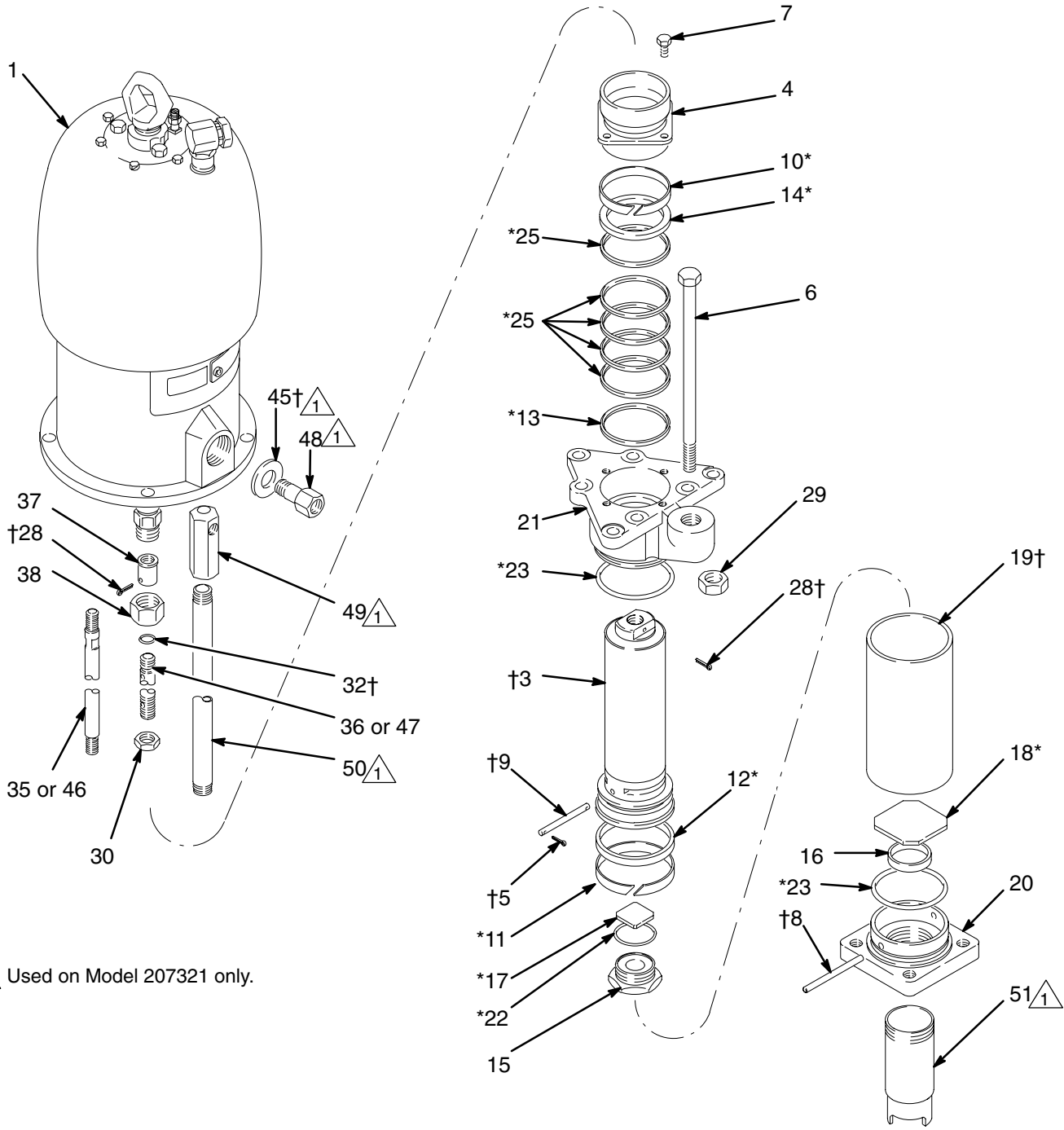

 Used on Model 207321 only.

06829

# Parts

## Rubber-Packed Pumps

### 206418 5:1 Bulldog Pump

Includes 1–38

### 207321 5:1 Bulldog Pump

Includes 1–32, 37, 38, 45–51

Ref No.	Part No.	Description	Qty.	Ref No.	Part No.	Description	Qty.
				18*	166066	. VALVE PLATE, 2–1/2" (64 mm) sq	1
				19†	166067	. CYLINDER	1
				20	166068	. HOUSING, intake valve	1
				21	166069	. HOUSING, outlet	1
				22*	115079	. O-RING, nitrile rubber	1
				23*	166071	. O-RING, nitrile rubber	2
				24*	166072	. V-PACKING, nitrile rubber	4
				25*	170627	. V-PACKING, UHMWPE	1
				28†	101946	. PIN, cotter; sst' 1/8" dia; 1–1/2 (38 mm) lg	2
				29	102216	LOCKNUT; sst; 5/8–11 thd sz	3
				30	102217	NUT, jam; sst; 3/4–10 thd sz	1
1	208356	AIR MOTOR See manual 307049 for parts	1	32†	158674	O-RING, nitrile rubber	1
2	206452	DISPLACEMENT PUMP ASSY. Includes items 3–25	1	35	166040	TIE ROD, 6.69" (170 mm) lg	3
3†	206451	. DISPLACEMENT ROD	1	36	166041	CONNECTING ROD, 1.63" (41.3 mm) lg	1
4	207171	. PACKING RETAINER, with solv. cup	1	37	166048	COUPLING SOCKET	1
5†	100063	. PIN, cotter; sst; 1/16" dia; 1/2" (13 mm) lg	2	38	166049	COUPLING NUT	1
6	102215	. SCREW, hex cap; sst; 5/8–11 thd size; 12" (305 mm) lg	4	45†	164661	WASHER, Hycar®	1
7	102471	. SCREW, hex cap; sst; 3/8–16 thd size; 1" (25 mm) lg	4	46	166042	TIE ROD, 14" (356 mm)	3
8†	166053	. STOP PIN, 4–1/16" (103 mm) lg	1	47	166043	CONNECTING ROD, 8.94" (227.1 mm)	1
9†	166054	. STOP PIN, 3–3/8" (86 mm) lg	1	48	166044	ADAPTER, 3/4 npt(m) x 24 npt (f)	1
10*	166055	. BEARING, PTFE	1	49	166045	90° ELBOW, 1" npt(f) x 3/4 npt(f)	1
11*	166056	. BEARING, PTFE	1	50	166046	SUPPLY TUBE, 13–9/16" (344 mm) lg	1
12*	166058	. PACKING, Hycar®	1	51	166047	INTAKE TUBE, 7" (178 mm) lg; 2" npt(m)	1
13*	166061	. GLAND, male	1				
14*	166062	. GLAND, female; PTFE	1				
15	166063	. VALVE SEAT, piston	1				
16	166064	. VALVE SEAT, piston	1				
17*	166065	. VALVE PLATE, 1–1/2" (38 mm) sq	1				

\* Supplied in Repair Kit 206931

† Recommended tool box spare parts. Keep on hand to reduce down time.

# Parts

PTFE-Packed Pump  
Model 206796

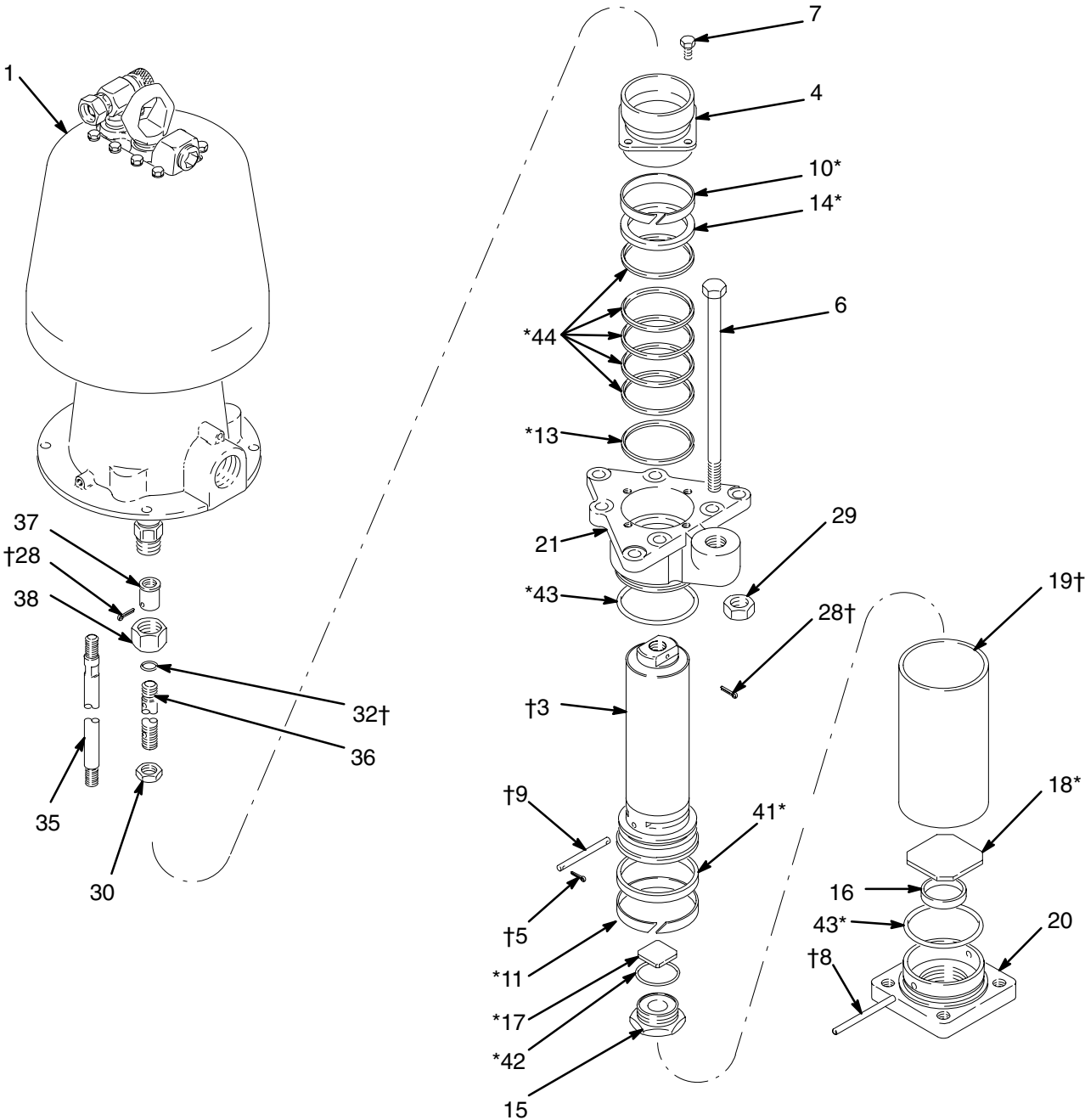

06829



# Parts

## PTFE-Packed Pumps

### 206796 5:1 Bulldog Pump Includes 1,28-44

Ref No.	Part No.	Description	Qty.	Ref No.	Part No.	Description	Qty.
				21	166069	. HOUSING, outlet	1
				28†	101946	. PIN, cotter; sst; 1/8" dia; 1-1/2 (38 mm) lg	2
				29	102216	LOCKNUT; sst; 5/8-11 thd sz	3
				30	102217	NUT, jam; sst; 3/4-10 thd sz	1
				32†	158674	O-RING, nitrile rubber	1
				35	166040	TIE ROD, 6.69" (170 mm) lg	3
				36	166041	CONNECTING ROD, 1.63" (41.3 mm) lg	1
1	208356	AIR MOTOR See manual 307049 for parts	1	37	166048	COUPLING SOCKET	1
3†	206451	. DISPLACEMENT ROD	1	38	166049	COUPLING NUT	1
4	207171	. PACKING RETAINER, with solv. cup	1	40	206453	DISPLACEMENT PUMP Includes items 3-11, 13-21, 41-44	1
5†	100063	. PIN, cotter; sst; 1/16" dia; 1/2" (13 mm) lg	2	41*	166057	. PACKING, PTFE	1
6	102215	. SCREW, hex cap; sst; 5/8-11 thd size; 12" (305 mm) lg	4	42*	166073	. O-RING, PTFE	1
7	102471	. SCREW, hex cap; sst; 3/8-16 thd size; 1" (25 mm) lg	4	43*	166074	. O-RING, PTFE	2
8†	166053	. STOP PIN, 4-1/16" (103 mm) lg	1	44*	166075	. V-PACKING, PTFE	5
9†	166054	. STOP PIN, 3-3/8" (86 mm) lg	1				
10*	166055	. BEARING, PTFE	1				
11*	166056	. BEARING, PTFE	1				
13*	166061	. GLAND, male	1				
14*	166062	. GLAND, female; PTFE	1				
15	166063	. VALVE SEAT, piston	1				
16	166064	. VALVE SEAT, piston	1				
17*	166065	. VALVE PLATE, 1-1/2" (38 mm) sq	1				
18*	166066	. VALVE PLATE, 2-1/2" (64 mm) sq	1				
19†	166067	. CYLINDER	1				
20	166068	. HOUSING, intake valve	1				

\* Supplied in Repair Kit 207349

† Recommended tool box spare parts. Keep on hand to reduce down time.

# Technical Data

Category	Data
Air operating range	40–100 psi (0.24–0.7 MPa, 2.4–7 bar)
Air volume required	1 cfm of air per gallon of fluid for each 15 psi of air
Maximum fluid pressure	500 psi (3.5 MPa, 35 bar)
Cycles per gallon (liter)	4 (1.1)
Recommended maximum pump speed	60 cycles per minute
Air inlet size	3/4 npt(f)
Wetted parts	<i>Models 206418 &amp; 207321:</i> 302, 303, 304 Stainless Steel, Nitrile Rubber, Hycar <sup>®</sup> , UHMWPE <i>Model 206796:</i> 302, 303, 304 Stainless Steel, PTFE, Hycar <sup>®</sup> UHMWPE
Weight	<i>Models 206418 &amp; 206796:</i> 92 lb (41 kg) <i>Model 207321:</i> 98 lb (44 kg)

Hycar<sup>®</sup> is a registered trademark of B.F. Goodrich.

## Mounting Hole Layout

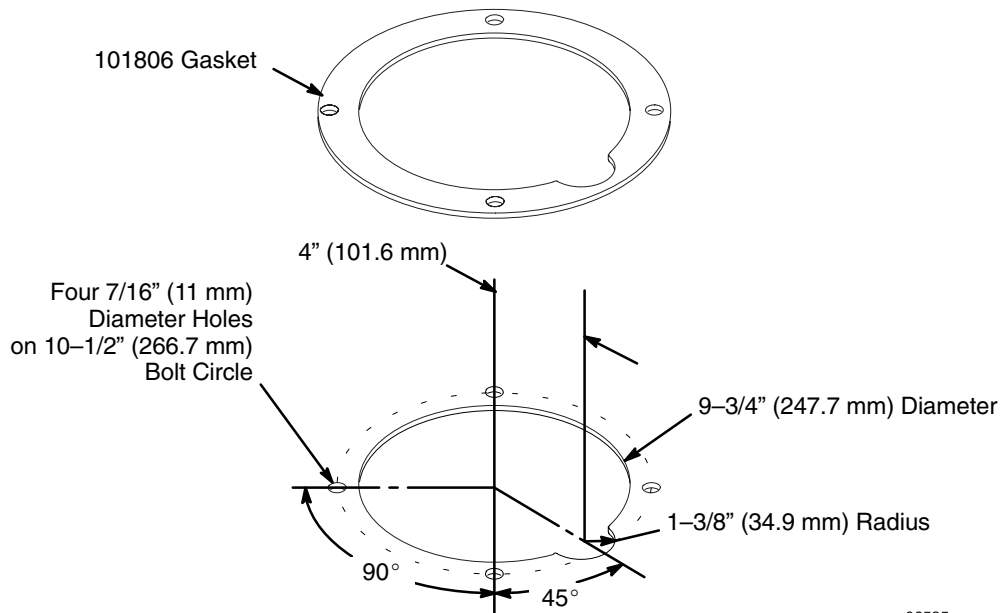

# Dimensions

**Models 207321,  
206418, and 206796**

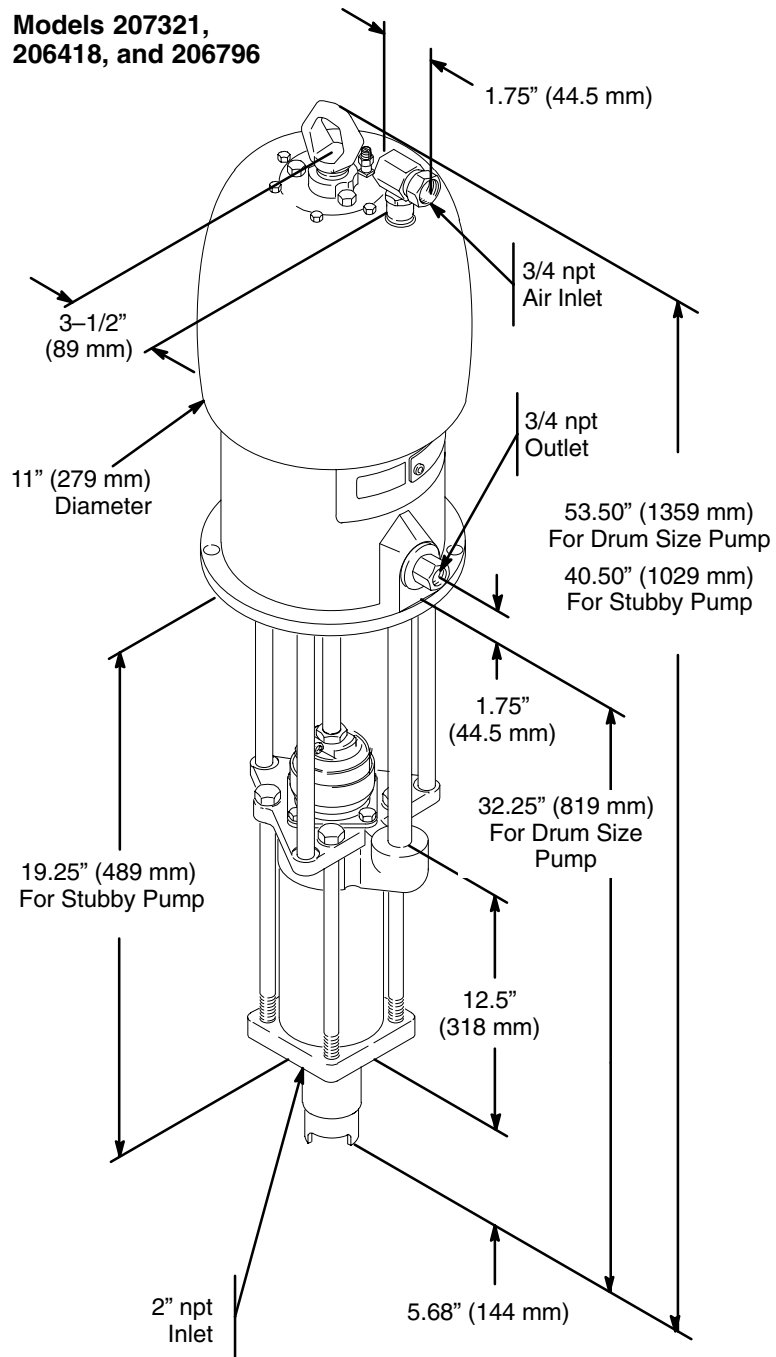

06830

# Graco Standard Warranty

Graco warrants all equipment listed in this manual which is manufactured by Graco and bearing its name to be free from defects in material and workmanship on the date of sale by an authorized Graco distributor to the original purchaser for use. With the exception of any special extended or limited warranty published by Graco, Graco will, for a period of twelve months from the date of sale, repair or replace any part of the equipment determined by Graco to be defective. This warranty applies only when the equipment is installed, operated and maintained in accordance with Graco's written recommendations.

This warranty does not cover, and Graco shall not be liable for general wear and tear, or any malfunction, damage or wear caused by faulty installation, misapplication, abrasion, corrosion, inadequate or improper maintenance, negligence, accident, tampering, or substitution of non-Graco component parts. Nor shall Graco be liable for malfunction, damage or wear caused by the incompatibility of Graco equipment with structures, accessories, equipment or materials not supplied by Graco, or the improper design, manufacture, installation, operation or maintenance of structures, accessories, equipment or materials not supplied by Graco.

This warranty is conditioned upon the prepaid return of the equipment claimed to be defective to an authorized Graco distributor for verification of the claimed defect. If the claimed defect is verified, Graco will repair or replace free of charge any defective parts. The equipment will be returned to the original purchaser transportation prepaid. If inspection of the equipment does not disclose any defect in material or workmanship, repairs will be made at a reasonable charge, which charges may include the costs of parts, labor, and transportation.

Graco's sole obligation and buyer's sole remedy for any breach of warranty shall be as set forth above. The buyer agrees that no other remedy (including, but not limited to, incidental or consequential damages for lost profits, lost sales, injury to person or property, or any other incidental or consequential loss) shall be available. Any action for breach of warranty must be brought within two (2) years of the date of sale.

**GRACO MAKES NO WARRANTY, AND DISCLAIMS ALL IMPLIED WARRANTIES OF MERCHANTABILITY AND FITNESS FOR A PARTICULAR PURPOSE IN CONNECTION WITH ACCESSORIES, EQUIPMENT, MATERIALS OR COMPONENTS SOLD BUT NOT MANUFACTURED BY GRACO.** These items sold, but not manufactured by Graco (such as electric motors, gas engines, switches, hose, etc.), are subject to the warranty, if any, of their manufacturer. Graco will provide purchaser with reasonable assistance in making any claim for breach of these warranties.

In no event will Graco be liable for indirect, incidental, special or consequential damages resulting from Graco supplying equipment hereunder, or the furnishing, performance, or use of any products or other goods sold hereto, whether due to a breach of contract, breach of warranty, the negligence of Graco, or otherwise.

## **FOR GRACO CANADA CUSTOMERS**

The parties acknowledge that they have required that the present document, as well as all documents, notices and legal proceedings entered into, given or instituted pursuant hereto or relating directly or indirectly hereto, be drawn up in English. Les parties reconnaissent avoir convenu que la rédaction du présente document sera en Anglais, ainsi que tous documents, avis et procédures judiciaires exécutés, donnés ou intentés à la suite de ou en rapport, directement ou indirectement, avec les procédures concernées.

# Graco Information

**TO PLACE AN ORDER**, contact your Graco distributor, or call one of the following numbers to identify the distributor closest to you:

**1-800-367-4023 Toll Free**

**612-623-6921**

**612-378-3505 Fax**

*All written and visual data contained in this document reflects the latest product information available at the time of publication.  
Graco reserves the right to make changes at any time without notice.*

**Sales Offices:** Minneapolis, Detroit  
**International Offices:** Belgium, Korea, Hong Kong, Japan

**GRACO INC. P.O. BOX 1441 MINNEAPOLIS, MN 55440-1441**

PRINTED IN U.S.A. 306818 09/1963, Revised 04/2003