



This manual contains important warnings and information.
READ AND KEEP FOR REFERENCE.

INSTRUCTIONS

First choice when quality counts.™

45:1 Ratio King® Pump

4050 psi (28 MPa, 279 bar) Maximum Working Pressure

90 psi (0.6 MPa, 6.2 bar) Maximum Air Input Pressure

Model 224434, Series A

Stubby Size, with Standard Air Motor and Severe-Duty Displacement Pump*, with leather packings

*Severe-Duty Displacement Pumps have an abrasion and corrosion-resistant displacement rod and sleeve. Refer to the Technical Data in the separate displacement pump manual 307728 for Wetted Parts information.

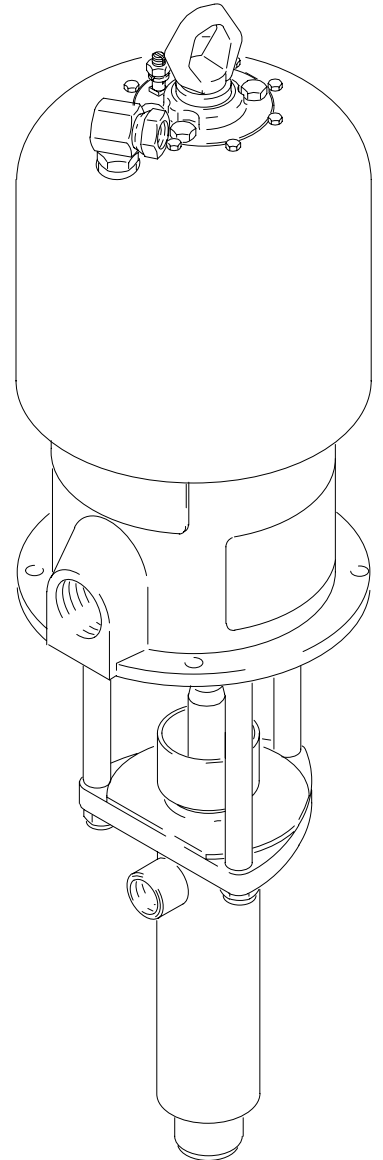

03290

Table of Contents

Warnings	2
Installation	4
Operation	7
Troubleshooting	9
Dimensions	14
Mounting Hole Layout	14
Technical Data	15
Graco Warranty	16
Graco Phone Number	16

Symbols

Warning Symbol



This symbol alerts you to the possibility of serious injury or death if you do not follow the instructions.

Caution Symbol



This symbol alerts you to the possibility of damage to or destruction of equipment if you do not follow the corresponding instructions.

! WARNING



INJECTION HAZARD

Spray from the gun, hose leaks, or ruptured components can inject fluid into your body and cause an extremely serious injury, including the need for amputation. Splashing fluid in the eyes or on the skin can also cause a serious injury.

- Fluid injected into the skin might look like just a cut, but it is a serious injury. **Get immediate medical attention.**
- Do not point the spray gun/dispensing valve at anyone or at any part of the body.
- Do not put hand or fingers over the spray tip/nozzle.
- Do not stop or deflect fluid leaks with your hand, body, glove, or rag.
- Do not “blow back” fluid; this is not an air spray system.
- Always have the tip guard and the trigger guard on the spray gun/dispensing valve when spraying/dispensing.
- Be sure the gun trigger safety operates before spraying.
- Lock the gun/valve trigger safety when you stop spraying.
- Follow the **Pressure Relief Procedure** on page 7 whenever you: are instructed to relieve pressure; stop spraying; clean, check, or service the equipment; and install or clean the spray tip.
- Tighten all the fluid connections before operating the equipment.
- Check the hoses, tubes, and couplings daily. Replace worn, damaged, or loose parts immediately. Permanently coupled hoses cannot be repaired; replace the entire hose.



TOXIC FLUID HAZARD

Hazardous fluids or toxic fumes can cause a serious injury or death if splashed in the eyes or on the skin, swallowed, or inhaled.

- Know the specific hazards of the fluid you are using. Read the fluid manufacturer’s warnings.
- Store hazardous fluid in an approved container. Dispose of the hazardous fluid according to all local, state, and national guidelines.
- Wear appropriate protective clothing, gloves, eyewear, and respirator.

Warnings are continued on the next page.

WARNING



FIRE AND EXPLOSION HAZARD

Improper grounding, poor air ventilation, open flames, or sparks can cause a hazardous condition and result in fire or explosion and serious injury.

- Ground the equipment and the object being sprayed/dispensed. See **Grounding** on page 4.
- Provide fresh air ventilation to avoid the buildup of flammable fumes from solvent or the fluid being sprayed.
- Extinguish all the open flames or pilot lights in the spray/dispensing area.
- Electrically disconnect all the equipment in the spray/dispensing area.
- Keep the spray/dispensing area free of debris, including solvent, rags, and gasoline.
- Do not turn on or off any light switch in the spray/dispensing area while operating or if fumes are present.
- Do not smoke in the spray/dispensing area.
- Do not operate a gasoline engine in the spray/dispensing area.
- If there is any static sparking while using the equipment, **stop spraying/dispensing immediately**. Identify and correct the problem.



INSTRUCTIONS



EQUIPMENT MISUSE HAZARD

Equipment misuse can cause the equipment to rupture, malfunction, or start unexpectedly and result in a serious injury.

- This equipment is for professional use only.
- Read all the instruction manuals, tags, and labels before operating the equipment.
- Use the equipment only for its intended purpose. If you are uncertain about usage, call your Graco distributor.
- Do not alter or modify this equipment. Use only genuine Graco parts and accessories.
- Check the equipment daily. Repair or replace worn or damaged parts immediately.
- Do not exceed the maximum working pressure of the lowest rated system component. This equipment has a **4050 psi (28.3 MPa, 283 bar) maximum working pressure**.
- Use fluids that are compatible with the equipment wetted parts. See the **Technical Data** section of all the equipment manuals. Read the fluid manufacturer's warnings.
- Route the hoses away from traffic areas, sharp edges, moving parts, and hot surfaces. Do not expose Graco hoses to temperatures above 180°F (82°C) or below -40°F (-40°C).
- Do not use the hoses to pull equipment.
- Wear hearing protection when operating this equipment.
- Comply with all applicable local, state, and national fire, electrical, and other safety regulations.



MOVING PARTS HAZARD

Moving parts, such as the air motor piston, can pinch or amputate fingers.

- Do not operate the equipment with the air motor plates removed.
- Keep clear of any moving parts when starting or operating the equipment.

Installation

Grounding

⚠ WARNING



FIRE AND EXPLOSION HAZARD

Before operating, ground the system as explained below. Also read the section **FIRE AND EXPLOSION HAZARD** on page 3.



To reduce the risk of static sparking, ground the pump and all other components used or located in the spray/dispensing area. Check your local electrical code for detailed instructions for your area and type of equipment and be sure to ground all of these components.

- **Pump:** loosen the grounding lug locknut (W) and washer (X). Insert one end of a 12 ga (1.5 mm²) minimum ground wire (Y) into the slot in lug (Z) and tighten the locknut securely. See Fig. 1. Connect the other end of the wire to a true earth ground.
- **Air and Fluid Hoses:** Use only electrically conductive hoses with a maximum of 500 feet (150 m) combined hose length to ensure grounding continuity.
- **Air Compressor:** follow the air compressor manufacturer's recommendations
- **Spray gun/dispensing valve:** obtain grounding through connection to a properly grounded fluid hose and pump.
- **Fluid supply container:** according to local code.
- **Object being sprayed:** according to local code.

- *All solvent pails used when flushing, according to local code. Use only metal pails, which are conductive. Do not place the pail on a non-conductive surface, such as paper or cardboard, which interrupts grounding continuity.*
- *To maintain grounding continuity when flushing or relieving pressure, always hold a metal part of the gun firmly to the side of a grounded metal pail, then trigger the gun.*

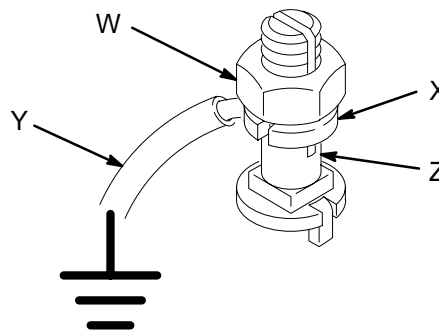

0864

Fig. 1

Flushing Safety

⚠ WARNING

To reduce the risk of serious injury whenever you are instructed to relieve pressure, always follow the **Pressure Relief Procedure** on page 7.

Before flushing, be sure the entire system and flushing pails are properly grounded. Refer to **Grounding** at left. Follow the **Pressure Relief Procedure** on page 7, and remove the spray tip/nozzle from the gun/dispensing valve. Always use the lowest possible fluid pressure, and maintain firm metal-to-metal contact between the gun/dispensing valve and the pail during flushing to reduce the risk of fluid injection injury, static sparking, and splashing.

Installation

Typical Installation

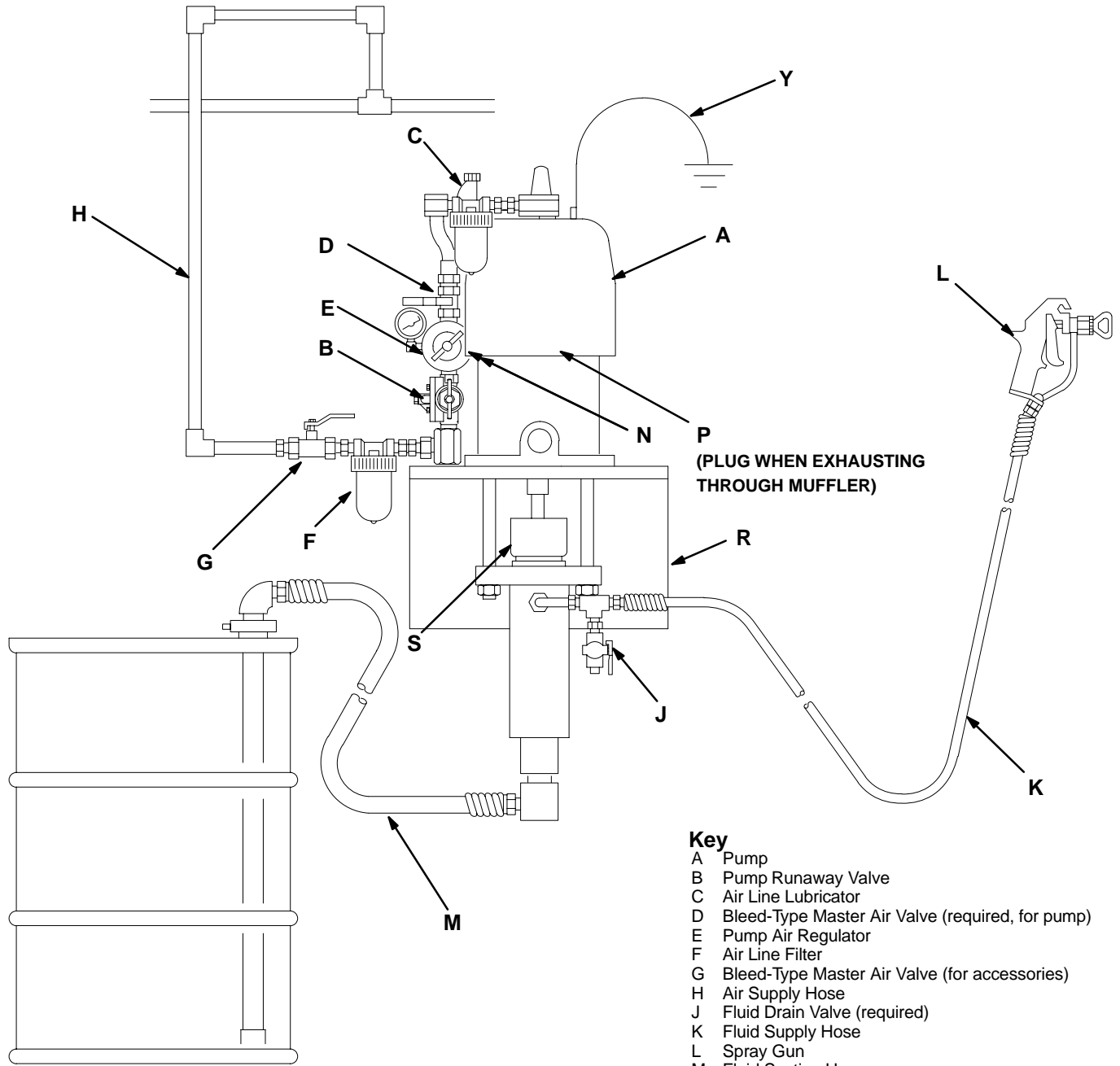

- Key**
- A Pump
 - B Pump Runaway Valve
 - C Air Line Lubricator
 - D Bleed-Type Master Air Valve (required, for pump)
 - E Pump Air Regulator
 - F Air Line Filter
 - G Bleed-Type Master Air Valve (for accessories)
 - H Air Supply Hose
 - J Fluid Drain Valve (required)
 - K Fluid Supply Hose
 - L Spray Gun
 - M Fluid Suction Hose
 - N Exhaust Port for Muffler (1-1/4" npt)
 - P 16 Exhaust Holes
 - R Wall Bracket
 - S Packing Nut/Wet-Cup
 - Y Ground Wire (required)

03291

Installation

NOTE: Reference numbers and letters in parentheses in the text refer to the callouts in the figures and the parts drawing.

NOTE: Accessories are available from your Graco distributor. If you supply your own accessories, be sure they are adequately sized and pressure-rated to meet the system's requirements.

The Typical Installation shown on page 5 is only a guide for selecting and installing system components and accessories. Contact your Graco distributor for assistance in designing a system to suit your particular needs.

System Accessories

Refer to the Typical Installation on page 5.

WARNING

Two accessories are required in your system: a bleed-type master air valve (D) and a fluid drain valve (J). These accessories help reduce the risk of serious injury including splashing in the eyes or on the skin, and injury from moving parts if you are adjusting or repairing the pump.

The bleed-type master air valve relieves air trapped between this valve and the pump after the air is shut off. Trapped air can cause the pump to cycle unexpectedly. Locate the valve close to the pump.

The fluid drain valve assists in relieving fluid pressure in the displacement pump, hose, and gun. Triggering the gun to relieve pressure may not be sufficient.

Mounting Accessories

Mount the pump (A) to suit the type of installation planned. The pump dimensions and mounting hole layout are shown on page 14. Use 3/8 in. bolts, lock-washers, and nuts to attach the pump firmly to the mounting.

Air and Fluid Hoses

Be sure all air and fluid hoses are properly sized and pressure-rated for your system. Use only electrically conductive air and fluid hoses. Fluid hoses must have spring guards on both ends.

Connect a electrically conductive fluid hose (H) to the pump's 1" npt(f) fluid outlet, using a suitable adapter.

Connect a fluid suction hose and tube (M) to the pump's 1-1/2" npt(f) fluid intake.

Use an electrically conductive 3/4 in. ID (minimum) air hose (H) to supply air to the pump.

Air Line Accessories

Install the following accessories in the order shown in the Typical Installation, using adapters as necessary:

- **An air line lubricator (C)** provides automatic air motor lubrication.
- **A bleed-type master air valve (D)** is required in your system to relieve air trapped between it and the motor when the valve is closed (see the **WARNING** at left). Be sure the bleed valve is easily accessible from the pump, and is located downstream from the air regulator.
- **A pump runaway valve (B)** senses when the pump is running too fast and automatically shuts off the air to the motor. A pump which runs too fast can be seriously damaged. Install closest to the pump air inlet.
- **An air regulator (E)** controls pump speed and outlet pressure by adjusting the air pressure to the pump. Locate the regulator close to the pump, but upstream from the bleed-type master air valve.
- **An air line filter (F)** removes harmful dirt and moisture from the compressed air supply.
- **A second bleed-type air valve (G)** isolates the air line accessories for servicing. Locate upstream from all other air line accessories.

Fluid Line Accessories

Install the following accessories in the order shown in the Typical Installation, using adapters as necessary:

- **A fluid drain valve (J)** is required in your system to relieve fluid pressure in the hose and gun (see the **WARNING** at left).
- **A spray gun (L)** dispenses the fluid. The gun shown in the Typical Installation is an airless spray gun.

Air Motor Exhaust

To route the air motor exhaust outside, remove the exhaust port plug and connect the hose to the 1-1/4 npt(f) exhaust port (N). Plug the 16 exhaust holes in the base of the motor with 1/4 in. size x 1/2 in. long self-tapping screws.

Operation

Pressure Relief Procedure

 **WARNING**

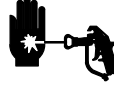

INJECTION HAZARD
Fluid under high pressure can be injected through the skin and cause serious injury. To reduce the risk of an injury from injection, splashing fluid, or moving parts, follow the **Pressure Relief Procedure** whenever you:

- are instructed to relieve the pressure,
- stop spraying,
- check or service any of the system equipment,
- or install or clean any part of the system.

1. Lock the spray gun/dispensing valve trigger safety.
2. Shut off the air to the pump.
3. Close the bleed-type master air valve (required in your system).
4. Unlock the trigger safety.
5. Hold a metal part of the gun/valve firmly to the side of a grounded metal pail, and trigger the gun/valve to relieve pressure.
6. Lock the trigger safety.
7. Open the drain valve (required in your system), having a container ready to catch the drainage.
8. Leave the drain valve open until you are ready to spray again.

If you suspect that the spray tip/nozzle is completely clogged, or that pressure has not been fully relieved after following the steps above, very slowly loosen the retaining nut or hose end coupling and relieve pressure gradually, then loosen completely. Now clear the tip/nozzle or hose.

Operation

WARNING

Moving parts can pinch or amputate your fingers or other body parts. When air is supplied to the motor, the air motor piston (located behind the air motor shield) moves. Therefore, never operate the pump with the air motor shield removed.

Flush the Pump Before Using

The pump is tested with lightweight motor oil, which is left in to protect the pump parts. If the fluid you are pumping may be contaminated by the oil, flush out the oil with a compatible solvent before using the pump. If the pump is being used to supply a circulating system, allow the solvent to circulate until the pump is thoroughly flushed.

WARNING

For your safety, read the warning section, **FIRE AND EXPLOSION HAZARD** on page 3 before flushing, and follow all instructions given there.

Starting and Adjusting the Pump

WARNING

To reduce the risk of serious injury whenever you are instructed to relieve pressure, always follow the **Pressure Relief Procedure** on page 7.

See the Typical Installation on page 5. Be sure the air regulator (E) and bleed-type master air valve (D) are closed. Do not install the spray tip yet.

Connect a suction hose (M) to the pump's fluid inlet. Hold a metal part of the spray gun (L) firmly to the side of a grounded metal pail and hold the trigger open. Then open the pump's bleed-type master air valve (D). Now slowly open the air regulator until the pump starts, about 20 psi (140 kPa, 1.4 bar).

Cycle the pump slowly until all the air is pushed out, and fluid is flowing from the gun in a steady stream. Release the spray gun trigger and lock the trigger safety. The pump should stall against pressure when the trigger is released.

Relieve the pressure, then install the spray tip in the gun.

In a direct supply system, with the pump and lines primed and with adequate air pressure and volume supplied, the pump will start and stop as the spray gun is opened and closed. In a circulating system, the pump will run continuously and will speed up or slow down as supply demands until the air supply is shut off.

Use an adequately sized air regulator (E) to control the pump speed and the fluid pressure. Always use the lowest air pressure necessary to get the desired results. Higher pressures waste fluid and cause premature wear of the pump packings and spray tip.

Keep the packing nut/wet-cup (S) half filled with Graco Throat Seal Liquid (TSL) or compatible solvent, to help prolong the packing life. Adjust the packing nut weekly with the wrench (supplied) so it is just tight enough to prevent leakage; do not overtighten. Always **relieve the pressure** before adjusting the packing nut.

Never allow the pump to run dry of the fluid being pumped. A dry pump will quickly accelerate to a high speed, possibly damaging itself. A pump runaway valve (B), which shuts off the air supply to the pump if the pump accelerates beyond the pre-set speed, is available. See the Typical Installation on page 5. If your pump accelerates quickly, or is running too fast, stop it immediately and check the fluid supply. If the supply container is empty and air has been pumped into the lines, refill the container and prime the pump and the lines with fluid, or flush and leave it filled with a compatible solvent. Be sure to eliminate all air from the fluid system.

Shutdown and Care of the Pump

For overnight shutdown, **relieve the pressure**. Always stop the pump at the bottom of the stroke to prevent the fluid from drying on the exposed displacement rod and damaging the throat packings.

Always flush the pump before the fluid dries on the displacement rod. Never leave water or water-based fluid in the pump overnight. First, flush with water or a compatible solvent, then with mineral spirits. **Relieve the pressure**, but leave the mineral spirits in the pump to protect the parts from corrosion.

Check Valve Adjustment

Refer to the separate displacement pump manual 307728 for check valve adjustment information.

Troubleshooting

WARNING

To reduce the risk of serious injury whenever you are instructed to relieve pressure, always follow the **Pressure Relief Procedure** on page 7.

Before servicing this equipment always make sure to **Relieve the Pressure**.

Note: Check all possible causes and solutions before disassembling the pump.

Problem	Cause	Solution
Pump fails to operate	Restricted line or inadequate air supply	Clear; increase air supply.
	Obstructed fluid hose, gun, or dispensing valve	Open, clear.*
	Exhausted fluid supply	Refill; Purge all air from pump and fluid lines.
	Fluid dried on displacement rod	Clean; always stop pump at bottom of stroke; keep wet-cup 1/2 filled with compatible solvent.
	Damaged air motor	Service air motor (see manual 306968).
Pump operates but output low on both strokes	Restricted line or inadequate air supply	Clear; increase air supply.
	Obstructed fluid hose, gun, or dispensing valve	Open, clear.*
	Exhausted fluid supply	Refill; purge all air from pump and fluid lines.
	Air in displacement pump and hose	Reprime.
	Check valves need adjustment	Adjust (see manual 307728).
	Packing nut too tight or too loose	Adjust (see manual 307728).
	Worn throat packings	Replace (see manual 307728).
Pump operates but output low on down stroke	Held open or worn intake valve	Clear; service (see manual 307728).
Pump operates but output low on up stroke	Held open or worn fluid piston valve or packings	Clear, service (see manual 307728).
Erratic or accelerated operation	Exhausted fluid supply	Refill; purge all air from pump and fluid lines.
	Packing nut too tight	Adjust (see manual 307728).
	Check valves need adjustment	Adjust (see manual 307728).
	Held open or worn intake valve	Clear; service (see manual 307728).
	Held open or worn fluid piston valve or packings	Clear; service (see manual 307728).

* To determine if the fluid hose or gun/valve is obstructed, **relieve the pressure**. Disconnect the fluid hose and place a container at the pump fluid outlet to catch any fluid. Turn on the air just enough to start the pump (about 20–40 psi [140–280 kPa, 1.4–2.8 bar]). If the pump starts when the air is turned on, the obstruction is in the fluid hose gun/valve.

Service

WARNING

To reduce the risk of serious injury whenever you are instructed to relieve pressure, always follow the **Pressure Relief Procedure** on page 7.

Disconnecting the Displacement Pump

1. Flush the pump, if possible. Stop the pump at the bottom of its stroke. **Relieve the pressure.**
2. Disconnect the air and fluid hoses. Remove the pump from its mounting. Note the relative position of the pump's fluid outlet (A) to the air motor's air inlet (B). See Fig. 2.
3. Screw the coupling nut (32) off of the air motor piston rod. Be careful not to lose the two couplers (33) as you lower the nut. Unscrew the tie rod locknuts (26) from the tie rods (31). Carefully pull the displacement pump (2) away from the air motor (1).
4. Refer to the instruction manual 307728 (supplied) for displacement pump service instructions.
5. Refer to instruction manual 306968 (supplied) for air motor service instructions.

Reconnecting the Displacement Pump

1. Orient the pump's fluid outlet (A) to the air motor's air inlet (B) as was noted in step 2 under **Disconnecting the Displacement Pump**. Position the displacement pump (2) on the tie rods (31).
2. Place the coupling nut (32) on the connecting rod (T). Insert the couplers (33) into the coupling nut from the top. Screw the coupling nut (32) onto the air motor piston rod. Screw the locknuts (26) onto the tie rods (31) loosely.
3. Mount the pump and reconnect all hoses. Reconnect the ground wire if it was disconnected during repair.
4. Tighten the tie rod locknuts (109) evenly, and torque to 40–50 ft-lb (54–68 N•m).
5. Tighten the packing nut/wet-cup (S) with the wrench (28) supplied, so it is just snug - no tighter. Fill the wet-cup 1/2 full with Graco Throat Seal Liquid (TSL) or compatible solvent. Start the pump and run it slowly at about 20 psi (140 kPa, 1.4 bar) air pressure, to check that it is operating properly.

Service

1 Torque to 40–50 ft-lb
(54–68 N•m)

2 Torque to 145–155 ft-lb
(195–210 N•m)

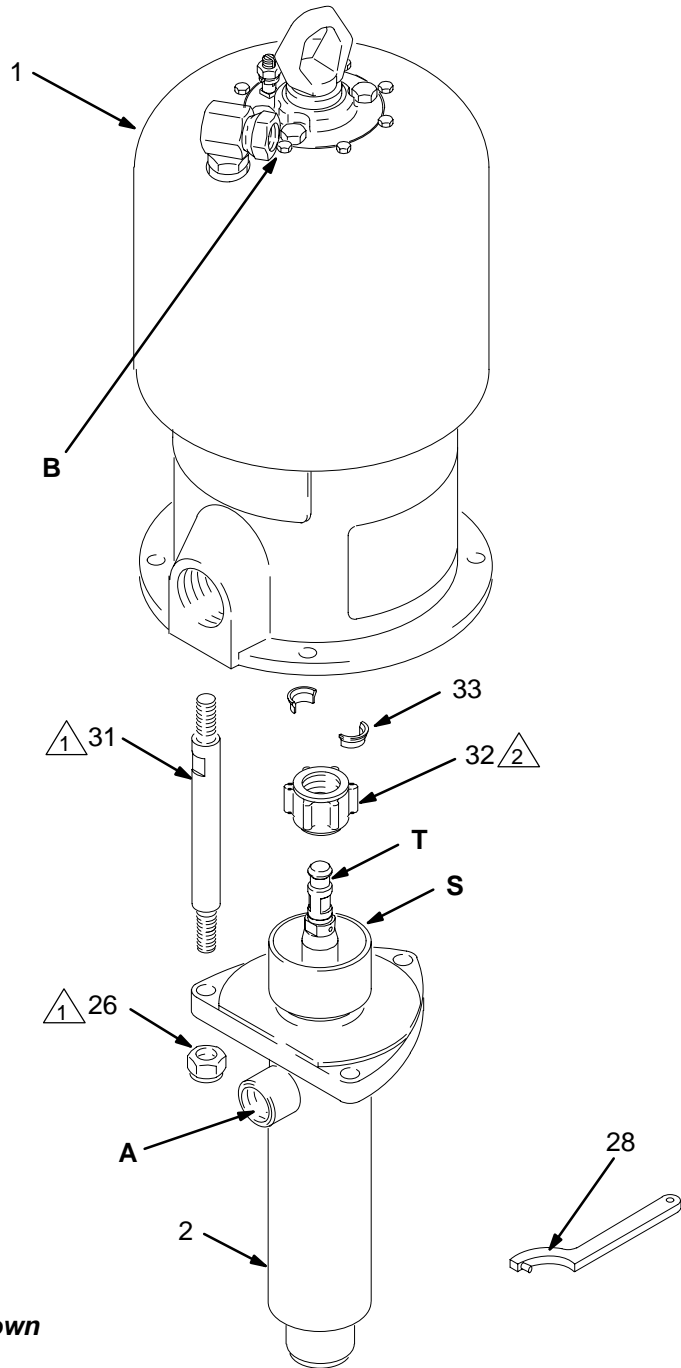

Model 224434 shown

03293

Fig. 2

Parts

Model 224434, Series A
Stubby Size, with Standard Air Motor and
Severe-Duty Displacement Pump with leather
packings

Includes items 1–33

Ref. No.	Part No.	Description	Qty.
1	207647	AIR MOTOR See Manual 306968 for parts	1
2	224435	DISPLACEMENT PUMP ASSY See Manual 307728 for parts	1
26	101712	NUT, lock; 5/8–11	3
28	102176	WRENCH	1
31	167911	ROD. tie; 7" (178 mm), shoulder-to-shoulder	3
32	186925	NUT, coupling	1
33	184129	COUPLING	1

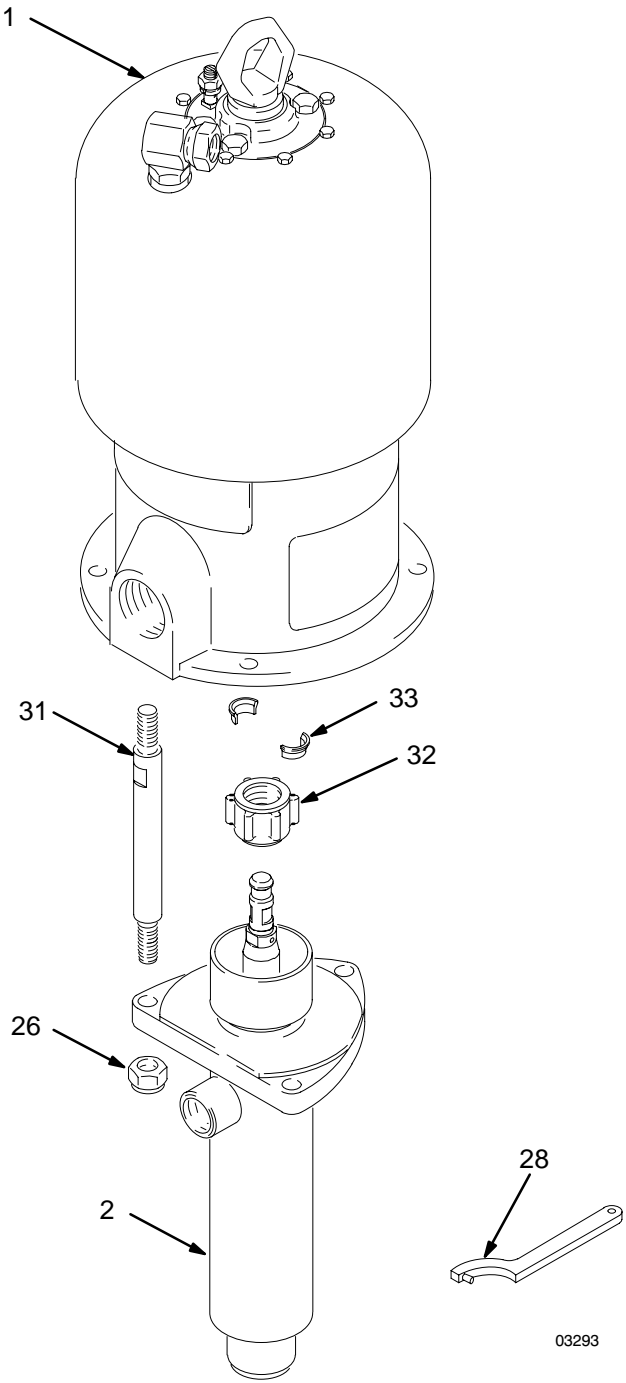

03293

Dimensions

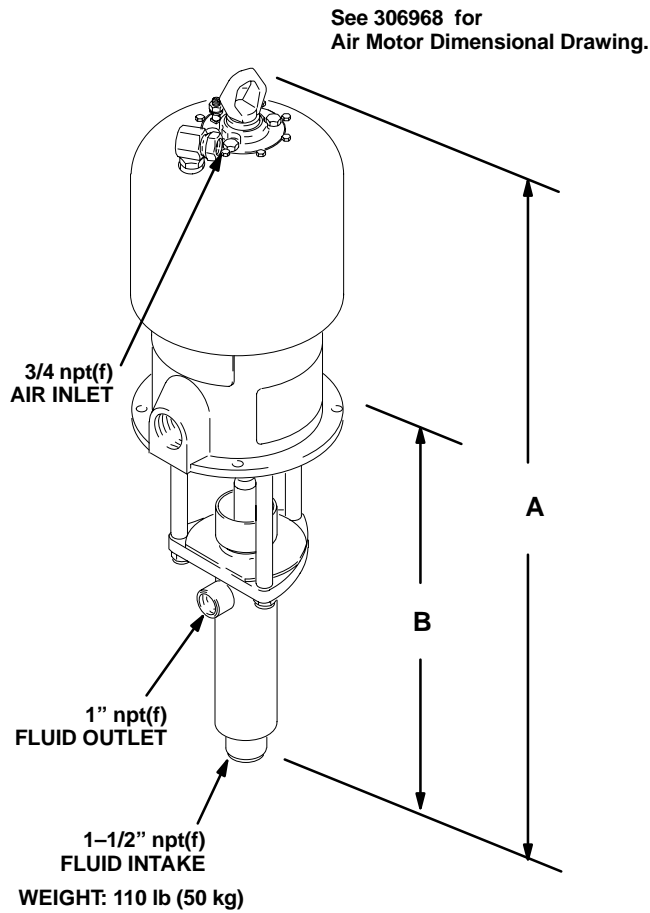

03290

Pump Model	A	B
224434,	42.5 in. (1079.5 mm)	21 in. (533.4 mm)

Mounting Hole Layout

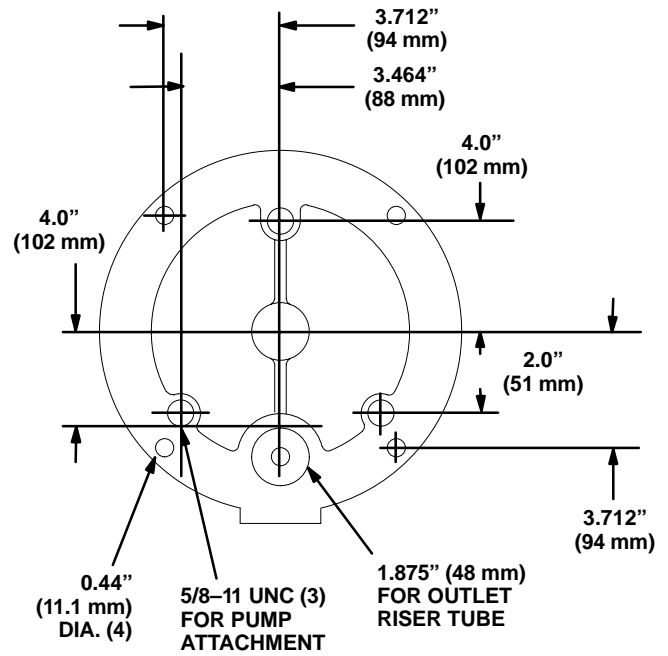

01838

Technical Data

Category	Data
Maximum fluid working pressure	4050 psi (28 MPa, 279 bar)
Maximum air pressure (see cover)	90 psi (0.6 MPa, 6.2 bar)
Pump cycles per 1 gallon (3.8 liters)	16
Fluid flow at 50 cpm	3.3 gpm (12 liter/min)
Wetted parts	See displacement pump manual 307728

Sound Pressure Levels (dBa) (measured at 1 meter from unit)

Air Motor	Input Air Pressures at 15 cycles per minute		
	0.28 MPa, 2.8 bar (40 psi)	0.48 MPa, 4.8 bar (70 psi)	0.6 MPa, 6.2 bar (90 psi)
King	78.8	82.7	90.5

Sound Power Levels (dBa) (tested in accordance with ISO 9614-2)

Air Motor	Input Air Pressures at 15 cycles per minute		
	0.28 MPa, 2.8 bar (40 psi)	0.48 MPa, 4.8 bar (70 psi)	0.6 MPa, 6.2 bar (90 psi)
King	86.5	88.8	97.7

Performance Chart

To find Fluid Outlet Pressure (psi/MPa/bar) at a specific fluid flow (lpm/gpm) and operating air pressure (psi/MPa/bar):

1. Locate desired flow along bottom of chart.
2. Follow vertical line up to intersection with selected fluid outlet pressure curve (black). Follow left to scale to read fluid outlet pressure.

To find Pump Air Consumption (m³/min or scfm) at a specific fluid flow (lpm/gpm) and air pressure (psi/MPa/bar):

1. Locate desired flow along bottom of chart.
2. Read vertical line up to intersection with selected air consumption curve (dashes). Follow left to scale to read air consumption.

- A 0.6 MPa, 6.2 bar (90 psi) air pressure
- B 0.5 MPa, 4.9 bar (70 psi) air pressure
- C 0.3 MPa, 2.8 bar (40 psi) air pressure

Test Fluid: No. 10 Weight Oil

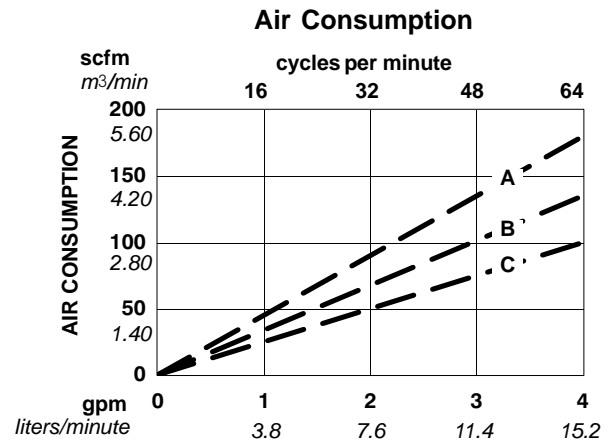
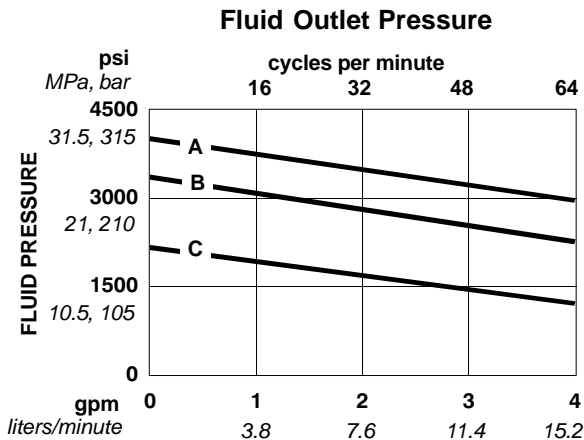

The Graco Standard Warranty

Graco warrants all equipment manufactured by Graco and bearing its name to be free from defects in material and workmanship on the date of sale by an authorized Graco distributor to the original purchaser for use. With the exception of any special, extended, or limited warranty published by Graco, Graco will, for a period of twelve months from the date of sale, repair or replace any part of the equipment determined by Graco to be defective. This warranty applies only when the equipment is installed, operated and maintained in accordance with Graco's written recommendations.

This warranty does not cover, and Graco shall not be liable for general wear and tear, or any malfunction, damage or wear caused by faulty installation, misapplication, abrasion, corrosion, inadequate or improper maintenance, negligence, accident, tampering, or substitution of non-Graco component parts. Nor shall Graco be liable for malfunction, damage or wear caused by the incompatibility of Graco equipment with structures, accessories, equipment or materials not supplied by Graco, or the improper design, manufacture, installation, operation or maintenance of structures, accessories, equipment or materials not supplied by Graco.

This warranty is conditioned upon the prepaid return of the equipment claimed to be defective to an authorized Graco distributor for verification of the claimed defect. If the claimed defect is verified, Graco will repair or replace free of charge any defective parts. The equipment will be returned to the original purchaser transportation prepaid. If inspection of the equipment does not disclose any defect in material or workmanship, repairs will be made at a reasonable charge, which charges may include the costs of parts, labor, and transportation.

THIS WARRANTY IS EXCLUSIVE, AND IS IN LIEU OF ANY OTHER WARRANTIES, EXPRESS OR IMPLIED, INCLUDING BUT NOT LIMITED TO WARRANTY OF MERCHANTABILITY OR WARRANTY OF FITNESS FOR A PARTICULAR PURPOSE.

Graco's sole obligation and buyer's sole remedy for any breach of warranty shall be as set forth above. The buyer agrees that no other remedy (including, but not limited to, incidental or consequential damages for lost profits, lost sales, injury to person or property, or any other incidental or consequential loss) shall be available. Any action for breach of warranty must be brought within two (2) years of the date of sale.

Graco makes no warranty, and disclaims all implied warranties of merchantability and fitness for a particular purpose in connection with accessories, equipment, materials or components sold but not manufactured by Graco. These items sold, but not manufactured by Graco (such as electric motors, switches, hose, etc.), are subject to the warranty, if any, of their manufacturer. Graco will provide purchaser with reasonable assistance in making any claim for breach of these warranties.

In no event will Graco be liable for indirect, incidental, special or consequential damages resulting from Graco supplying equipment hereunder, or the furnishing, performance, or use of any products or other goods sold hereto, whether due to a breach of contract, breach of warranty, the negligence of Graco, or otherwise.

FOR GRACO CANADA CUSTOMERS

The parties acknowledge that they have required that the present document, as well as all documents, notices and legal proceedings entered into, given or instituted pursuant hereto or relating directly or indirectly hereto, be drawn up in English. Les parties reconnaissent avoir convenu que la rédaction du présente document sera en Anglais, ainsi que tous documents, avis et procédures judiciaires exécutés, donnés ou intentés à la suite de ou en rapport, directement ou indirectement, avec les procédures concernées.

Graco Phone Number

TO PLACE AN ORDER, contact your Graco distributor, or call this number to identify the distributor closest to you:
1-800-367-4023 Toll Free.

*All written and visual data contained in this document reflects the latest product information available at the time of publication.
Graco reserves the right to make changes at any time without notice.*

Sales Offices: Minneapolis, Detroit
Foreign Offices: Belgium, Korea, Hong Kong, Japan

www.graco.com
GRACO INC. P.O. BOX 1441 MINNEAPOLIS, MN 55440-1441

PRINTED IN U.S.A. 307013 August 1969, Revised May 2000