

INSTRUCTIONS-PARTS LIST



307-140

Rev. "C" 5-78
SUPERSEDES 10-74

This manual contains **IMPORTANT WARNINGS** and **INSTRUCTIONS**
READ AND RETAIN FOR REFERENCE

3:1 RATIO

PRESIDENT PUMP

540 PSI (37 bar) MAXIMUM WORKING PRESSURE

**MODEL 210-006 SERIES "E"
FOR WATER REDUCIBLE MATERIALS**

Air powered pump is easy to control; simply adjust air pressure.

Divorced design prevents air motor fouling.

Displacement pump valves are adjustable for varying viscosity requirements.

Accessories on page 5.

TECHNICAL DATA on back page.

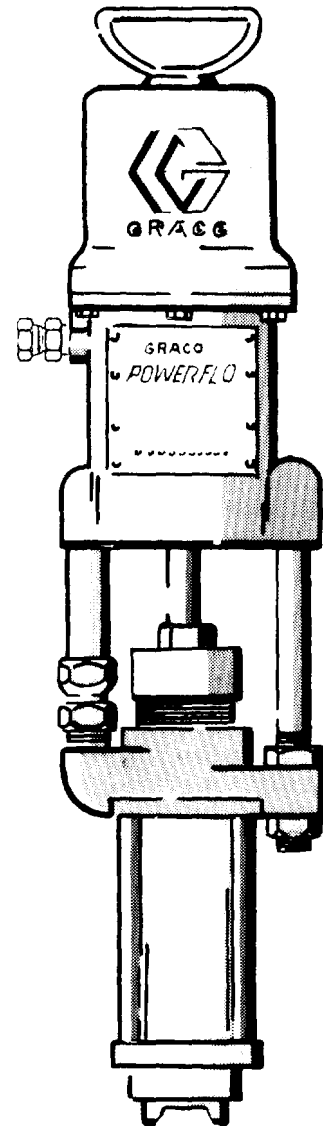

GRACO INC. P.O. BOX 1441 MINNEAPOLIS, MN 55440

© COPYRIGHT 1974 GRACO, INC.

INSTALLATION

Mount Pump

Mount pump to suit the type of installation planned. Mounting accessories are shown on page 5. Pump dimensional drawings and mounting hole layout are given on page 5.

Connect Hoses

Connect a 0.5 in. (13 mm) minimum ID air supply hose to the 3/8 npt (f) inlet (A) of pump or 1/2 npt(f) swivel union supplied with the pump. Main air supply line should include a bleed type master air valve (B) for shutting off and relieving pressure to pump. See Fig 1.

Connect a 0.75 in. (19 mm) minimum ID fluid hose to the 3/4 npt (m) outlet (C) of pump. If pump is supplying a circulating system, connect a 0.5 in. (13 mm) minimum ID hose to return (D) of pump.

If pump is to be supplied by suction hose, connect a 1.5 in. (38 mm) ID hose to the 1-1/2 npt pump inlet (D). If pump is to be supplied direct from the circulating or dead end supply line mount pump in line with suitable plumbing.

Whenever flammable materials are being pumped, connect a ground wire to pump air motor. Loosen grounding lug locknut (F) and washer (G), insert one end of a 12 ga (1.5 mm²) minimum ground wire into slot in lug (H) and tighten locknut securely. See Fig 1.

Connect the other end of wire to a good ground, such as a steel building column or water pipe. See ACCESSORIES for available ground wire and clamp.

We recommend installing an air line filter to remove dirt and moisture from the air supply. Downstream from the filter, install an air line oiler for automatic air motor lubrication. See ACCESSORIES. If you supply your own filter or oiler, be sure that it is adequately sized to meet your system air requirements.

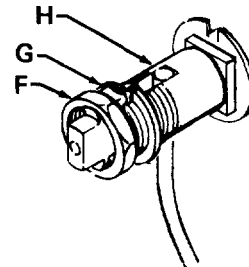
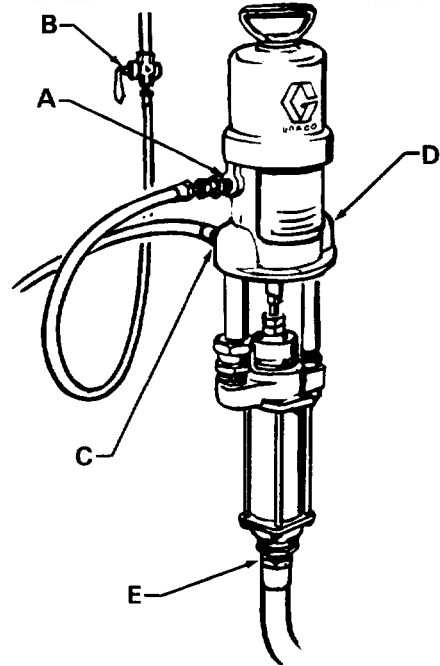

Fig 1

OPERATION

Adjusting Pump Speed and Pressure

In a direct supply system, with air supply turn on, the pump starts as the fluid valve is opened, and stalls against pressure when the fluid valve is closed. In a circulating system, the pump operates until the air supply is turned off.

Use an air regulator to control fluid pressure and pump speed. See page 5 for an accessory Graco air regulator. Always use the lowest air pressure needed to give the results you want.

Lubrication and Care

For automatic lubrication of the air motor, install the Graco air line oiler shown on page 5. For daily, manual lubrication, disconnect air supply, place about 15 drops of light oil in air inlet and reconnect air supply.

When operating the pump non-immersed, keep the wet cup (47) filled with Graco Throat Seal Liquid (TSL). See Fig 2.

If pump accelerates suddenly, or is running too fast, stop pump immediately and check fluid supply. If fluid supply has been exhausted and air has gotten into the system, immediately reprime pump and lines with material or flush and leave filled with the proper diluting agent for the material being pumped. Always stop the

pump at the bottom of its stroke to prevent material from drying on displacement rod (46) and damaging packings.

When pumping materials which dry, harden, or set up, flush system with the proper diluting agent as often as necessary to prevent a build-up.

For overnight and holiday shutdown, turn off air to pump and bleed off fluid pressure through gun. Remove and clean paint hoses and spray guns, and turn off all air to system.

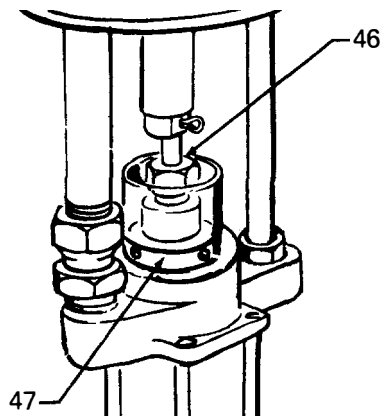

Fig 2

Fluid Piston & Intake Valve Adjustment

The fluid piston and intake valves are factory set for pumping medium viscosity fluids such as spray paint. Pin (34) in intake valve is in lower set of holes and piston ball travel is set at 0.19 in. (4.8 mm) or 4 complete turns of ball stop screw (45) from the top of piston ball.

1. If heavy viscosity paint is used and erratic pump operation develops, increase ball travel in intake valve by moving pin (34) to center or upper set of holes, and in piston valve by backing out ball stop screw 2 complete turns or 0.28 in. (7.1 mm) total travel. See Fig 3.

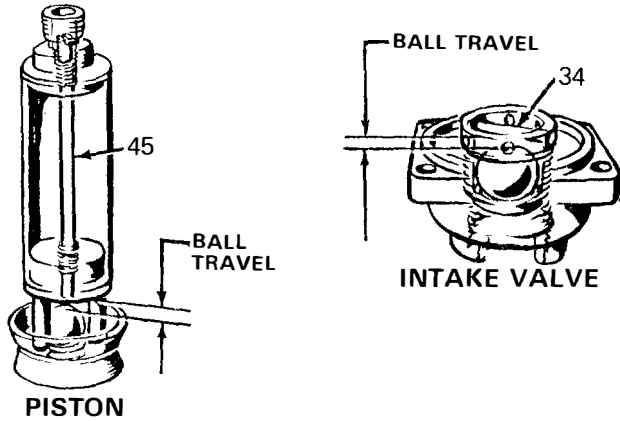

Fig 3

2. If extremely light paint is used and surging develops, reduce surging effect by screwing in ball stop screw 2 complete turns or 0.09 in. (2.3 mm) total travel at piston valve. See Fig 3.

Disassemble pump as explained on page 4 and adjust valves as follows: Place piston in vise as shown in Fig 4, loosen upper displacement rod cap (44) to relieve tension on ball stop screw (45), adjust ball stop screw for desired ball travel and retighten upper displacement rod cap securely. Refer to Fig 4. Set intake valve pin as desired and reassemble pump.

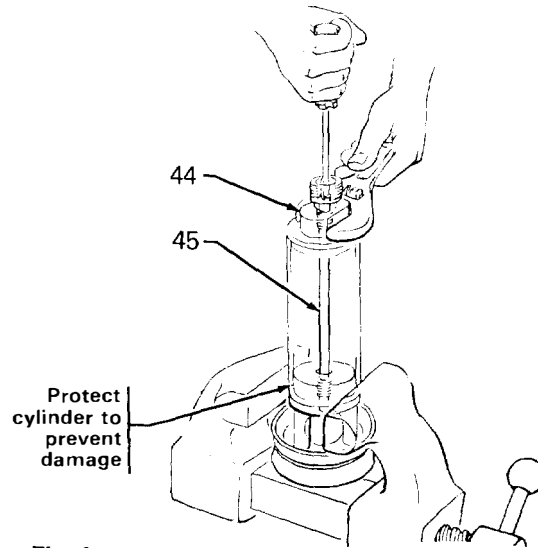

Fig 4

SERVICE

TROUBLESHOOTING CHART

What's Wrong

- Pump fails to operate
- Pump operates but—
 - output low on both strokes
 - output low on down stroke
 - output low on up stroke
- Erratic or accelerated operation

Why

- Restricted line or inadequate air supply
- Insufficient air pressure— closed or clogged air valves, etc.
- Exhausted material supply
- Obstructed material line, valves, gun, etc.
- Fluid check valves need adjustment
- Loose throat packing nut or worn packings
- Held open or worn fluid intake valve
- Held open or worn fluid piston or packing
- Damaged air motor

What To Do

- Clear; increase
- Open, clean
- Refill
- Clear*
- Adjust
- Tighten nut or replace packings
- Clear, service
- Clear, service
- Service

WARNING
Always disconnect air supply and relieve all pressures before attempting any service. Never operate pump with air motor plates removed.

*Release pressures and disconnect material line. Turn on air — if pump starts the line, etc. is clogged.

Check all other possible remedies before disassembling pump.

Fluid Pump Service

Flush pump with the proper diluting agent; relieve pressures, remove pump from system and disassemble as explained below.

Unscrew coupling nut (32) from displacement rod cap (44). Unscrew lower locknut (10) from return mounting tube (12) and swivel union (21) from supply mounting tube (11). See Fig 5. If mounting tubes are to be removed, wrench tubes close to air motor base to prevent thread damage in base.

Unscrew the four tie bolts (17) from pump head (27), loosen packing nut (47) and disassemble fluid pump as necessary to correct trouble. See Fig 6.

NOTE: If ball stop pin (34) or screw (45) are to be removed, note their position before removal and reinstall in proper location.

Clean and inspect all parts carefully for wear or damage and replace as necessary. Give special attention to displacement rod cylinder (46) and cylinder (37), packings (25 & 26) valve balls (15 & 16), and seats (29 & 51).

Lubricate, assemble and install all parts of fluid pump reverse from disassembly. Refer to Fig 6. Install new

wiper ring (22) and throat V-packings (26) one at a time. Leave packing nut (47) loose until displacement rod cylinder (46) is installed. Then tighten packing nut (47) to within one turn of point where threads bottom out.

CAUTION

Do not attempt to reseat balls (15 & 16) in intake or fluid piston valves. The hard seats (29 & 51) are easily chipped.

Place fluid pump on mounting tubes (11 & 12). Thread upper locknut (10) onto return mounting tube a couple of turns and tighten swivel union (21) securely onto supply mounting tube (11). Refer to Fig 5. Butt connecting rod (53) and displacement rod cap (44) together and adjust locknuts (10) on return mounting tube to align rods. Then tighten locknuts securely, being careful not to disturb alignment. Tighten coupling nut (32) securely onto cap (44).

Operate pump at minimum air pressure; 50 PSI (3.5 bar) maximum. Adjust locknuts (10) on return mounting tube (12) as necessary until pump operates smoothly on 15 PSI (1 bar) or less. Then tighten nuts (10) securely. See Fig 5.

Remount pump in system and attach air and fluid lines.

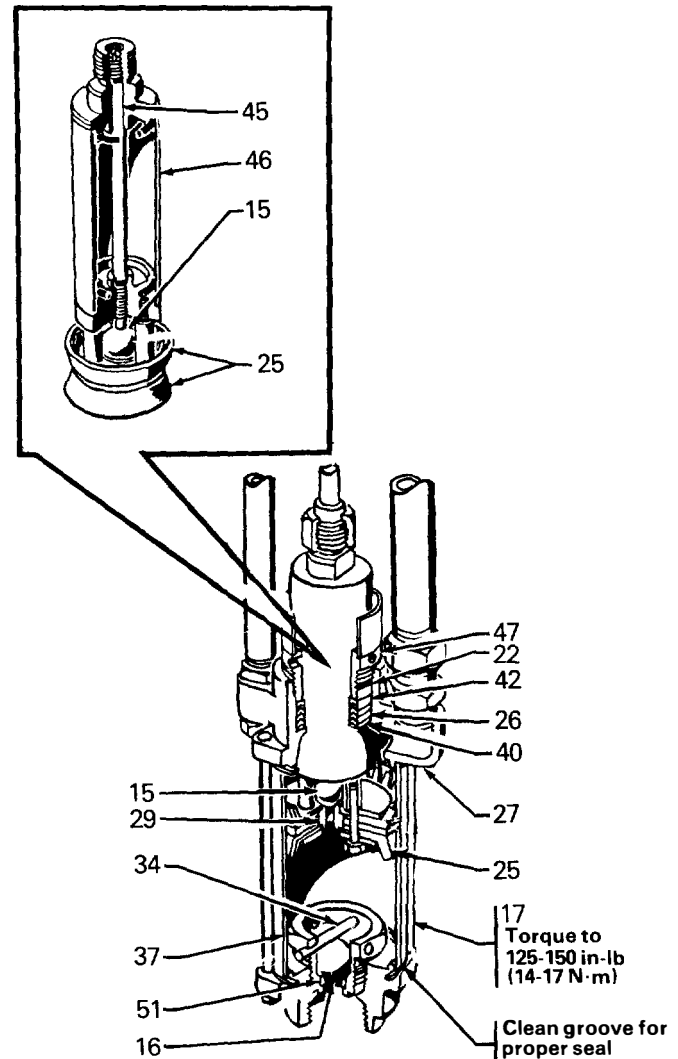
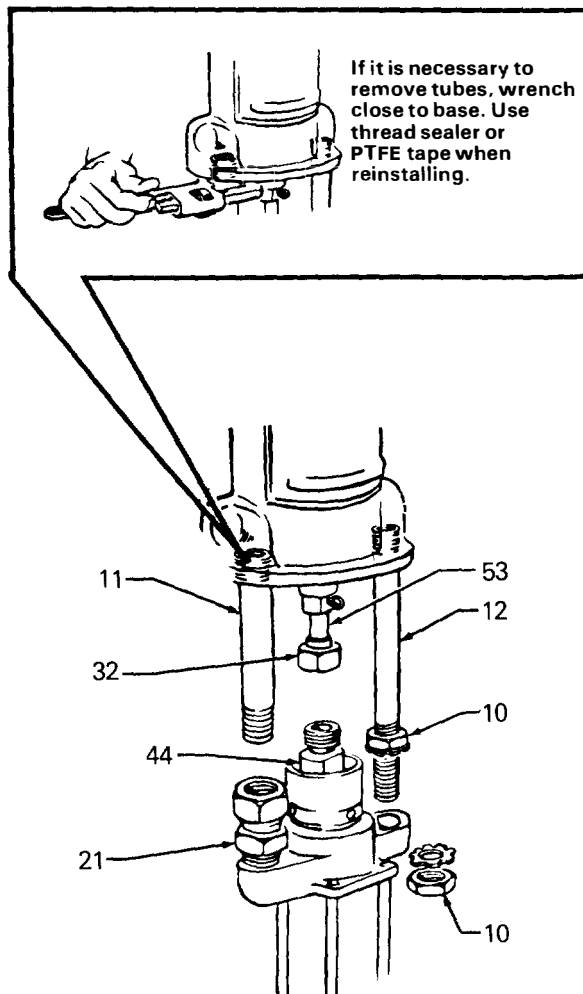
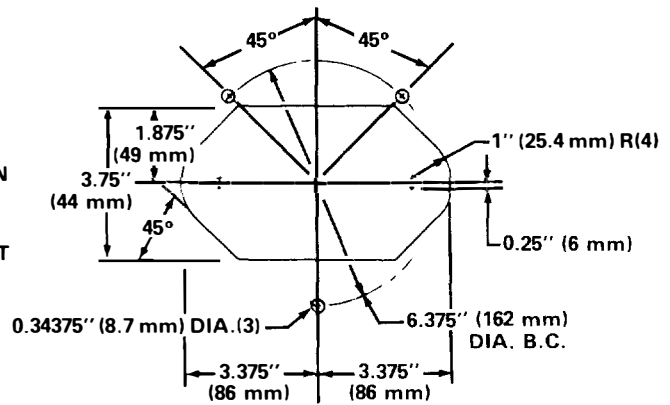
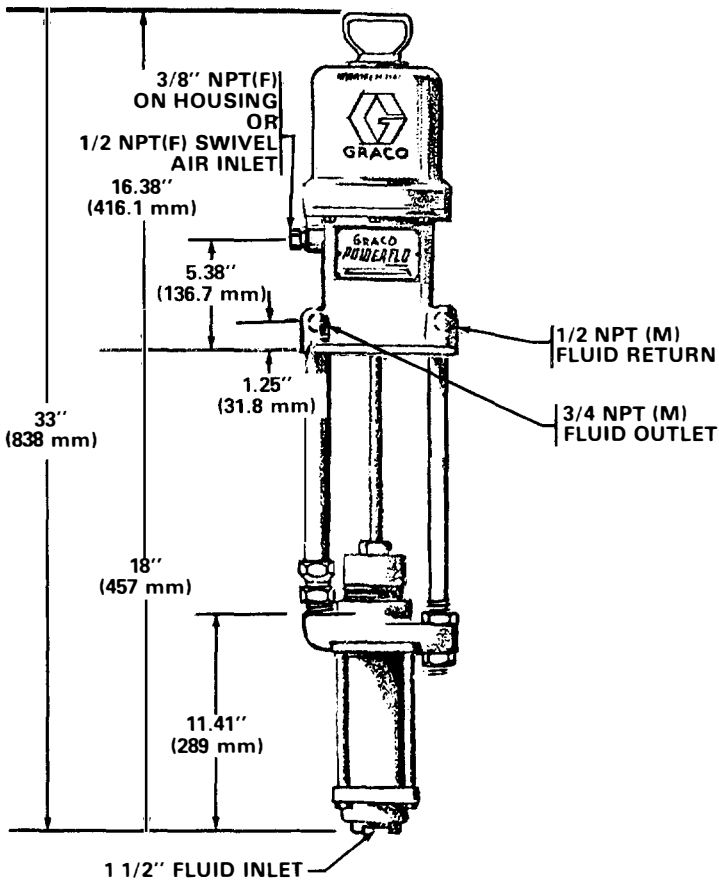

Fig 5

Fig 6

DIMENSIONAL DRAWING

MOUNTING HOLE LAYOUT



Use 161-322 pump mounting gasket.

ACCESSORIES (Must be purchased separately)

SAFETY MIXING TANKS

- 210-035, 30 Gallon
- 210-036, 15 Gallon

See instruction manual 307-153.

- Includes Fluid Couplers and Nipple
- 104-134 and 104-133 1/2 NPT)
- 104-136 and 104-135 (3/4 NPT)



206-220 WALL MOUNTING BRACKET

See instruction manual 306-783.

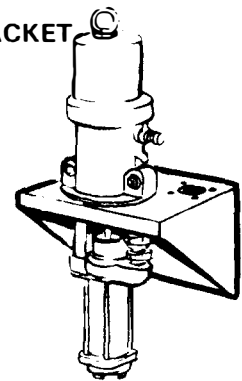

214-848 AIR LINE OILER

250 PSI (17.5 bar) MAXIMUM WORKING PRESSURE
1/2 NPT (F) inlet and outlet. See instruction manual 307-316.

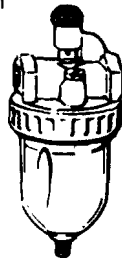

207-468 AIR REGULATOR KIT

400 PSI (28 bar) MAXIMUM SUPPLY PRESSURE
10-125 PSI (7-11 bar) REGULATED PRESSURE
See instruction manuals 306-972 and 307-153.

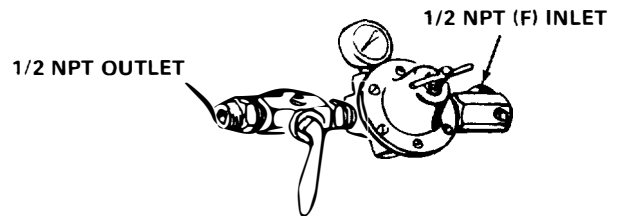

203-421 AIR LINE MOISTURE SEPARATOR

200 PSI (14 bar) MAXIMUM WORKING PRESSURE
See instruction manual 306-393. 1/2" NPT inlet and outlet.

GROUNDING WIRE AND CLAMP

- See instruction manual 307-255.
- 103-538 Grounding Clamp
- 208-950 Ground Wire
25 ft (7.6 m) long

PARTS DRAWING
MODEL 210-006 SERIES "E"

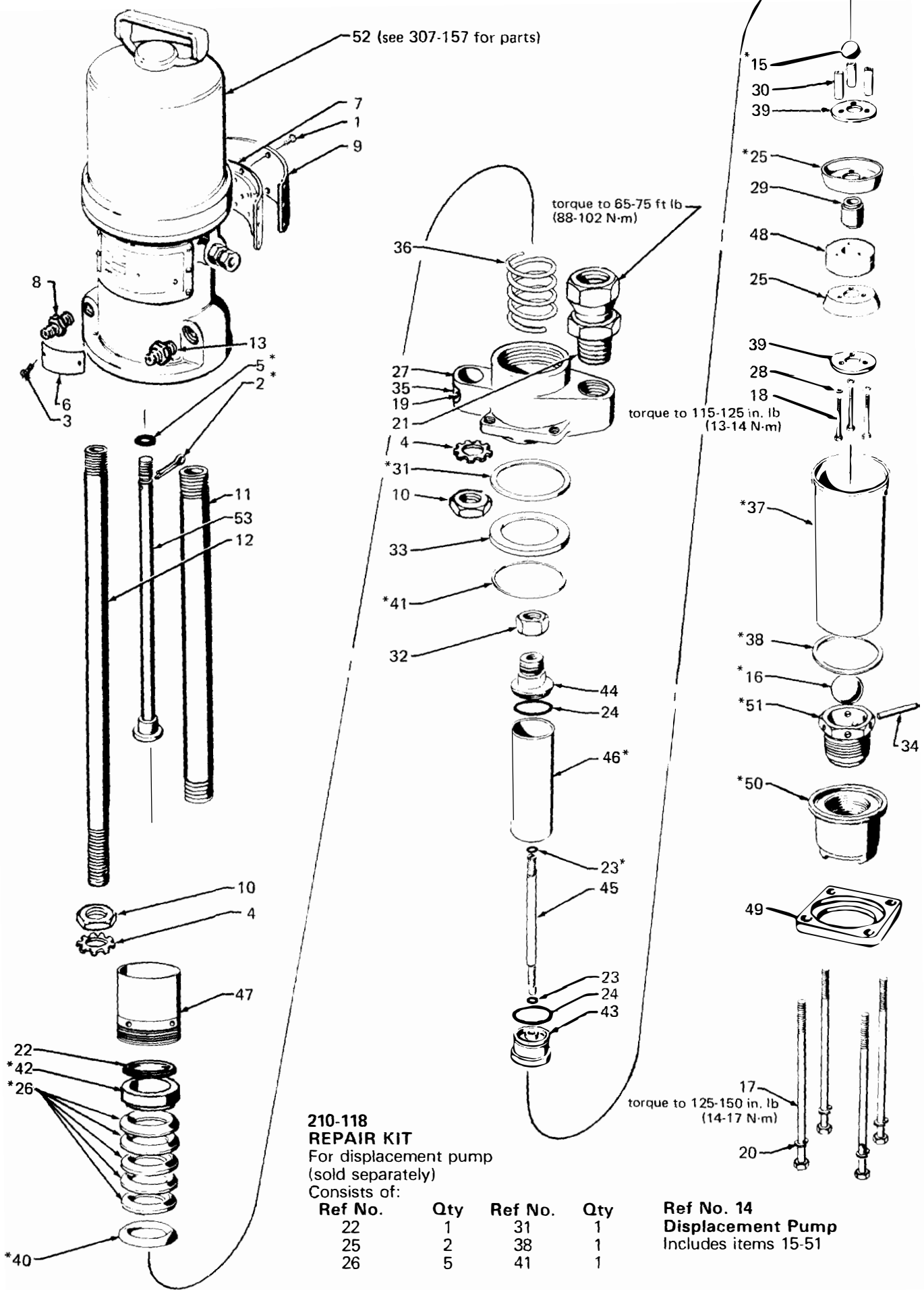

210-118
REPAIR KIT
For displacement pump
(sold separately)
Consists of:

Ref No.	Qty	Ref No.	Qty
22	1	31	1
25	2	38	1
26	5	41	1

Ref No. 14
Displacement Pump
Includes items 15-51

PARTS LIST

REF NO.	PART NO.	DESCRIPTION	QTY	REF NO.	PART NO.	DESCRIPTION	QTY
1	100-078	SCREW, rd hd mach; 8-32 x 3/8	8	24	160-325	. O-RING, nitrile rubber	2
2	*100-579	PIN, cotter; 11" (2.8 mm) x 1" (25 mm) long	1	25	*164-920	. PACKING, cup; PTFE	2
3	104-088	RIVET, blind	2	26	166-769	. V-PACKING; PTFE	5
4	103-960	LOCKWASHER, external tooth; 1" (25 mm) ID	2	27	175-004	. HOUSING, outlet	1
5	*156-082	O-RING, nitrile rubber	1	28	171-163	. WASHER	3
6	172-446	PLATE, designation	1	29	171-164	. SEAT, valve	1
7	162-654	PLATE, muffler	1	30	171-167	. SPACER	3
8	166-443	NIPPLE, hex reducing; 3/4 npt x 1/2 npt	1	31	*171-169	. GASKET, nylon	1
9	172-456	PLATE, identification	1	32	171-171	. NUT, coupling	1
10	170-217	LOCKNUT, 3/4-11	2	33	171-174	. RETAINER, spring	1
11	171-228	TUBE, supply mounting	1	34	171-176	. PIN, straight headless	1
12	171-229	TUBE, return mounting	1	35	171-178	. PLATE, designation	1
13	171-439	NIPPLE, hex reducing; 1" npt x 3/4 npt	1	36	171-181	. SPRING, tapered compression	1
14	214-619	DISPLACEMENT PUMP ASSY Series "A" includes items 15-51	1	37	*175-008	. CYLINDER, fluid	1
15	*101-917	. BALL, .88" (22.4 mm) dia	1	38	*171-206	. GASKET, nylon	1
16	*101-968	. BALL, 1.25" (31.8 mm) dia	1	39	171-208	. WASHER, piston	2
17	103-961	. CAPSCREW, hex hd; 3/8-16 x 9"	4	40	*171-209	. GLAND, packing; male	1
18	103-971	. CAPSCREW, hex hd; 3/8-16 x 2-1/4	3	41	*171-210	. GASKET, nylon	1
19	103-972	. SCREW, type "u" drive; 1/8 x 3/16	3	42	*171-211	. GLAND, packing; female, Celcon	1
20	103-975	. LOCKWASHER, spring; 3/8	4	43	171-212	. CAP, displacement rod; lower	1
21	103-977	. UNION, straight adapter 1" npt(m) x 1" npsm(f)	1	44	171-213	. CAP, displacement rod; upper	1
22	103-988	. RING, wiper; nitrile rubber	1	45	171-214	. SCREW, adjusting	1
23	*156-082	. O-RING, nitrile rubber	2	46	*175-006	. ROD, cylinder	1
				47	171-223	. NUT, packing	1
				48	171-224	. BEARING, piston; Celcon	1
				49	171-250	. PLATE, tie	1
				50	171-251	. HOUSING, valve	1
				51	*214-618	. SEAT, valve	1
				52	210-007	AIR MOTOR (see 307-157 for parts)	1
				53	210-008	ROD, connecting	1

306 & 307 Numbers in description refer to separate instruction manuals.

*Recommended "tool box" spare parts. Keep on hand to reduce down time.

Order parts by name and number. Always give the model number and series letter of the assembly for which you are ordering.

SERVICE INFORMATION

Listed below by the assembly changed are OLD and NEW parts.

ASSEMBLY CHANGED	PART DESIGNATION	REF NO.	PART NO.	NAME
210-006 to Series "E"	OLD	3	102-556	Rivet
	NEW		104-088	Rivet
	OLD	6	160-637	Plate
	NEW		172-446	Plate
	OLD	9	167-692	Plate
	NEW		172-456	Plate
	OLD	14	210-001	Pump, Displ.
	NEW		214-619	Pump, Displ.
	OLD	27	171-156	Housing
	NEW		175-004	Housing
	OLD	37	171-203	Cylinder
	NEW		175-008	Cylinder
	OLD	46	171-215	Rod
	NEW		175-006	Rod
	OLD	51	209-016	Seat
	NEW		214-618	Seat

INTERCHANGEABILITY NOTE: NEW parts replace OLD parts listed directly above them.

TECHNICAL DATA

Normal air operating range : 40 to 120 PSI (3 to 8 bar)
Maximum air operating range : 180 PSI (12 bar)
Air consumption : 4 cfm per gallon pumped (.03 m³/min/liter) at
100 PSI (7 bar): Up to 44 cfm (1.23 m³/min) with
pump operated within recommended range.
Pump cycles per gallon (liter) : 6 (1.6)
Maximum recommended pump speed : 66 cycles per minute: 11 gpm (41 liter/min)
Recommended speed for optimum pump life : 15-25 cycles per minute: 2.5-4.0 gpm (9-15 liter/min)
Wetted parts : Stainless Steel, Nitralloy Steel; Nickel and Hard
Chrome Plated Stainless Steel; Electroless Nickel;
Nitrile Rubber; PTFE, Nylon; Celcon
Weight : 41 lb (18.6 kg)

THE GRACO WARRANTY

Graco Inc. warrants all equipment manufactured by it and bearing its name to be free from defects in material and workmanship under normal use and service. This warranty extends to the original purchaser for a period of 12 months from the date of purchase and applies only when the equipment is installed and operated in accordance with written factory recommendations. This warranty does not cover damage or wear which, in the reasonable judgment of Graco, arises from misuse, abrasion, corrosion, negligence, accident, substitution of non-Graco parts, faulty installation or tampering.

This warranty is conditioned upon the prepaid return of the equipment claimed to be defective for examination by Graco to verify the claimed defect. If the claimed defect is verified, Graco will repair or replace free of charge, any defective parts. The equipment will be returned to the original purchaser transportation prepaid. If inspection of the equipment does not disclose any defect in workmanship or material, repairs will be made at a reasonable charge and return transportation will be charged.

THIS LIMITED WARRANTY IS EXCLUSIVE, AND IS IN LIEU OF ANY OTHER WARRANTIES (EXPRESS OR IMPLIED) INCLUDING WARRANTY OF MERCHANTABILITY OR WARRANTY OF FITNESS FOR A PARTICULAR PURPOSE AND OF ANY NON-CONTRACTUAL LIABILITIES INCLUDING PRODUCT LIABILITIES BASED ON NEGLIGENCE OR STRICT LIABILITY. EVERY FORM OF LIABILITY FOR DIRECT, SPECIAL OR CONSEQUENTIAL DAMAGES OR LOSS IS EXPRESSLY EXCLUDED AND DENIED.

EQUIPMENT NOT COVERED BY GRACO WARRANTY. Accessories or components of equipment sold by Graco that are not manufactured by Graco (such as electric motors, switches, hose, etc.) are subject to the warranty, if any, of their manufacturer. Graco will provide purchaser with reasonable assistance in making such claims.

Factory Branches: Atlanta, Cleveland, Dallas, Detroit (Southfield), Los Angeles, West Caldwell (N.J.)
Subsidiary and Affiliate Companies: Canada; England; Switzerland; France; Germany; Hong Kong; Japan
GRACO INC. P.O. BOX 1441 MINNEAPOLIS, MN 55440