

Fluid Pressure Regulators

307212ZAK

STAINLESS STEEL, WATERBASE COMPATIBLE

EN

Used to regulate fluid pressure in low pressure systems only.

Fluid Flow up to 3GPM (11 liters/min)



Important Safety Instructions

Read all warnings and instructions in this manual before using the equipment. Be familiar with the proper control and usage of the equipment. Save these instructions.

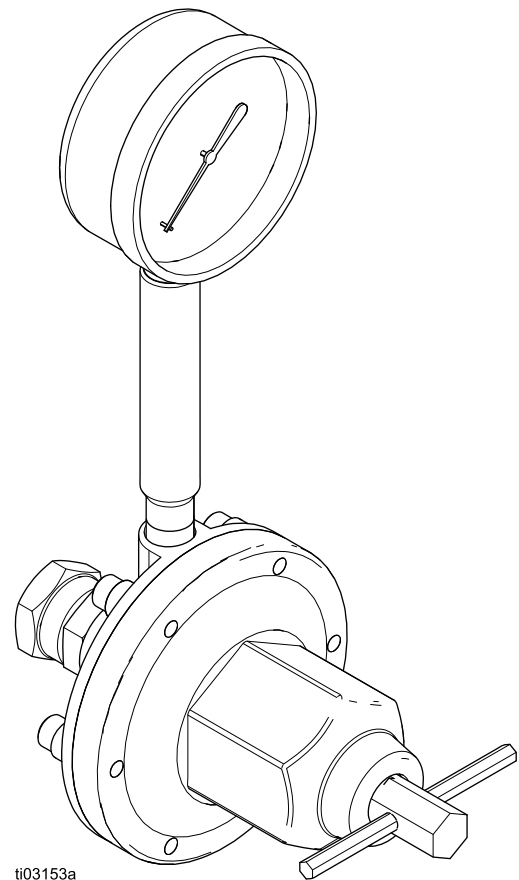

Contents

Contents	2	Notes	11
Models	3	Troubleshooting	12
Notes	4	Service	13
Safety Symbols	5	Service of the Air Operated Regulators	13
General Warnings	6	Service of the Spring Operated Regulators	15
Installation	7	Parts	17
Spring Operated Installation	7	Model 214895, Series H	17
Pilot Regulator Air Supply Line Air Operated Installation	7	Model 214706, Series H	17
Before Installing the Fluid Regulator	8	Model 214980 Series F,	19
Installing the Fluid Regulator	8	Model 244375 Series B	20
Operation	9	Dimensions	21
Pressure Relief Procedure	9	Technical Data	22
Flushing Procedure	9	Performance Chart	23
Regulating Fluid Pressure	10	Graco Standard Warranty	24

Models

Spring Operated Fluid Regulators

Part No.	Series	Maximum Fluid Inlet Pressure, psi (kPa, bar)	Regulated Pressure Range, psi (kPa, bar)	Gauge	Gauge Pressure Range, psi (kPa, bar)
214895	H	250 (1800, 18)	5 -100 (34 -700, 0.3 -7)	No	n/a
214706★	H	250 (1800, 18)	5 -100 (34 -700, 0.3 -7)	Yes (see below)	0 -100 (0 -700, 0 -7)
24A082 ▼❖	A	250 (1800, 18)	5 -100 (34 -700, 0.3 -7)	Yes (see below)	0 -100 (0 -700, 0 -7)
26C160 ▼	A	250 (1800, 18)	5 -100 (34 -700, 0.3 -7)	Yes (see below)	0 -200 (0 -1400, 0 -14)
217314★	F	250 (1800, 18)	20 -160 (140 -1100, 1.4 -11)	Yes	0 -300 (0 -2100, 0 -21)
221118★	E	250 (1800, 18)	20 -160 (140 -1100, 1.4 -11)	No	n/a

▼ ISO pitch thread inlet and outlet. Not compatible with US standard pitch.

★ These models are  and  certified.

❖ Fluid housing coated with PTFE polymer.



The fluid supply system's main line pressures often exceed the pressure range of the gauge supplied with regulators 214706, 26C160, and 24A082. Exposing this gauge to excessive pressure can damage the gauge, causing inaccurate readings and the needle will not return to zero.

This damage is not covered by the Graco warranty.

Air Operated Fluid Regulator

Part No.	Series	Maximum Regulated Air Pressure, psi (kPa, bar)	Maximum Fluid Inlet Pressure, psi (kPa, bar)	Regulated Pressure Range, psi (kPa, bar)	Gauge	Gauge Pressure Range, psi (kPa, bar)
214980 †	F	30 (210, 2.1)	250 (1800, 18)	0 -30 (0 -210, 0 -2.1)	Yes	0 -30 (0 -210, 0 -2.1)
244375	B	100 (700, 7)	250 (1800, 18)	5 -100 (34 -700, 0.3 -7)	No	n/a

† Regulated air pressures from 30 -100 psi (210 - 690 kPa, 2.1 -6.9 bar) may be used if a 100 psi rated gauge is installed.

Safety Symbols

The following safety symbols appear throughout this manual and on warning labels. Read the table below to understand what each symbol means.

Symbol	Meaning
	Equipment Misuse Hazard
	Pressurized Equipment Hazard
	Skin Injection Hazard
	Splash Hazard
	Follow Pressure Relief Procedure









Safety Alert Symbol

This symbol indicates: Attention! Become Alert! Look for this symbol throughout the manual to indicate important safety messages.

General Warnings

The following warnings apply throughout this manual. Read, understand, and follow the warnings before using this equipment. Failure to follow these warnings can result in serious injury.

 <h2 style="margin: 0;">WARNING</h2>	
  	<p>PRESSURIZED EQUIPMENT HAZARD</p> <p>Spray from the gun, hose leaks, or ruptured components can splash fluid in the eyes or on the skin and cause serious injury.</p> <ul style="list-style-type: none"> • Do not stop or deflect fluid leaks with your hand, body, glove, or rag. • Follow the Pressure Relief Procedure on page 8 whenever you: are instructed to relieve the pressure; stop spraying; clean, check, or service the equipment; and install or clean the fluid nozzle. • Tighten all the fluid connections before operating the equipment. • Check the hoses, tubes, and couplings daily. Replace worn, damaged, or loose parts immediately. Permanently coupled hoses cannot be repaired; replace the entire hose.
 	<p>EQUIPMENT MISUSE HAZARD</p> <p>Equipment misuse can cause the equipment to rupture, malfunction, or start unexpectedly and result in a serious injury.</p> <ul style="list-style-type: none"> • This equipment is for professional use only. • Read all the instruction manuals, tags, and labels before operating the equipment. • Use the equipment only for its intended purpose. If you are uncertain about usage, call your Graco distributor. • Do not alter or modify this equipment. Use only genuine Graco parts and accessories. • Check the equipment daily. Repair or replace worn or damaged parts immediately. • Do not exceed the maximum working pressure of the lowest rated system component. • Use fluids that are compatible with the equipment wetted parts. See the Technical Data section of all the equipment manuals. Read the fluid manufacturer's warnings. • Never use 1,1,1-trichloroethane, methylene chloride, other halogenated hydrocarbon solvents, or fluids containing such solvents in these regulators. In the event that there is a diaphragm failure, a serious chemical reaction could occur, with the possibility of explosion. • Route the hoses away from traffic areas, sharp edges, moving parts, and hot surfaces. Do not expose Graco hoses to temperatures above 180°F (82°C) or below -40°F (-40°C). • Never kink or over bend the hoses or use the hoses to pull equipment. • Comply with all applicable local, state, and national fire, electrical, and other safety regulations.

Installation

Spring Operated Installation

Models 214895, 214706, 217314,
221118, and 24A082

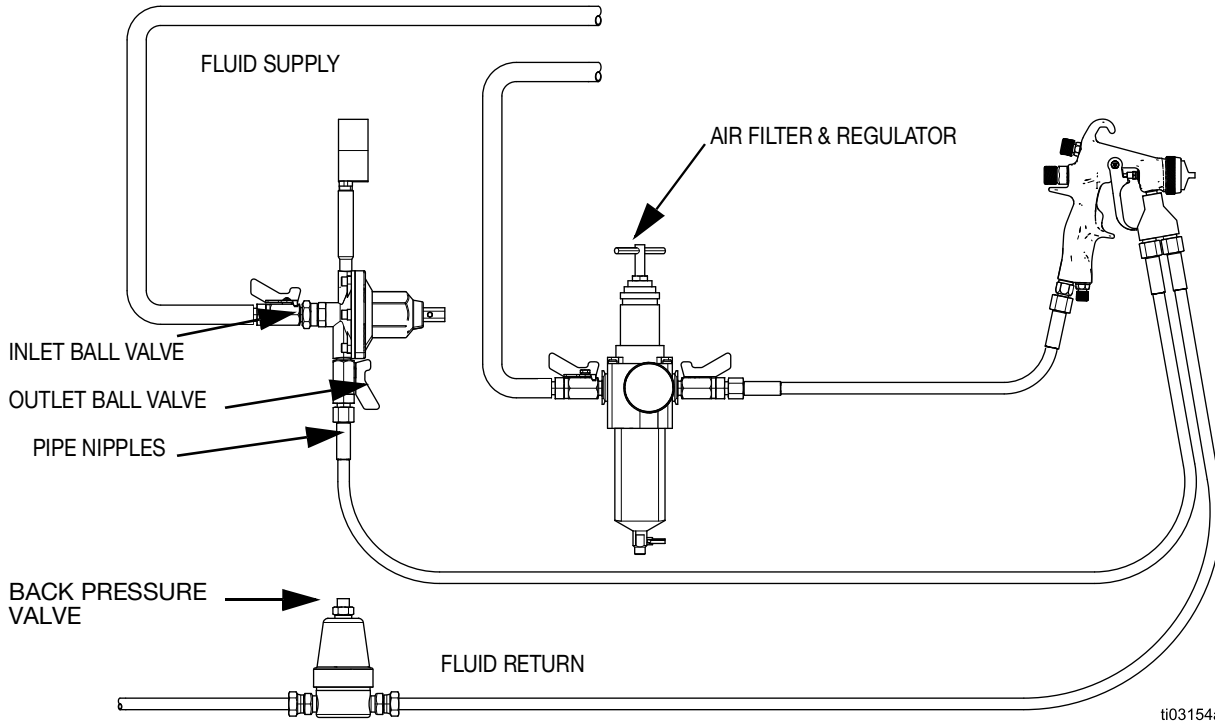

FIG. 1

ti03154a

Pilot Regulator Air Supply Line Air Operated Installation

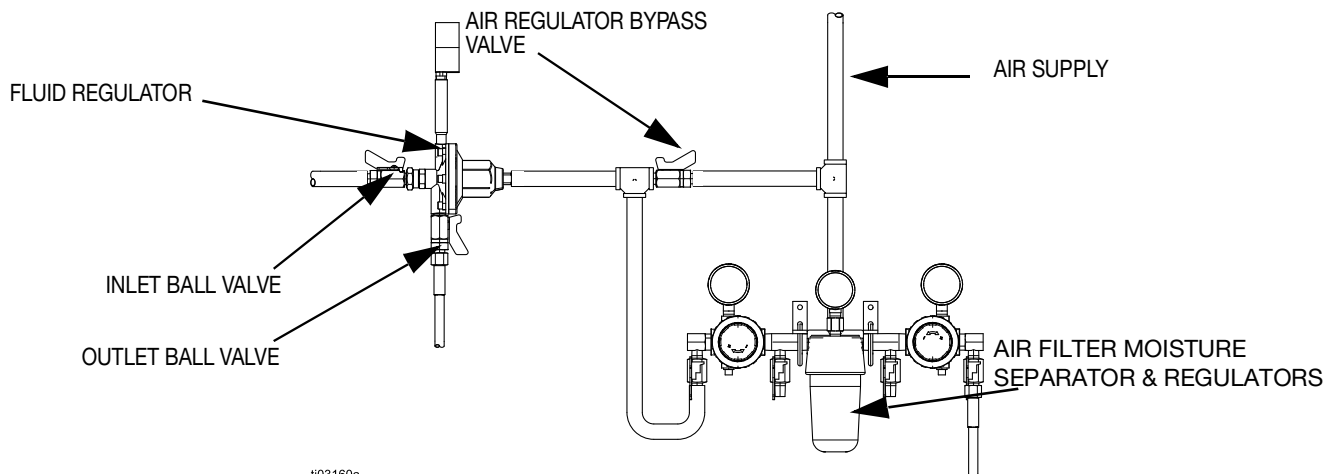

FIG. 2: Model 214980

Fluid pressure regulators are used for accurate, positive control of the fluid pressure to spray guns, dispensing valves or atomizing heads.

Regulators installed at circulating line take-offs or pumps are used to reduce main line pressure and maintain the desired fluid pressure to the spray gun or atomizing head.

Before Installing the Fluid Regulator

1. Determine where to locate the regulator.
2. Install a ball valve for the regulator inlet and outlet.
3. Install temporary plumbing between the ball valves.
4. Thoroughly flush the system to remove metal chips and other contaminants and to check for leaks.

Installing the Fluid Regulator

1. Remove the temporary plumbing and install one regulator for each spray gun. See the **Dimensions**, page 21, for regulator dimensions. Mount the regulator in a vertical position, as shown in FIG. 1 and FIG. 2, for the best flow and minimum pigment settling. The gauge, if used, must be mounted vertically. If the regulator is mounted horizontally, an elbow must be used so the gauge will be vertical.
2. Put sealer on threaded connections, except on the swiveling end of swivel unions as it interferes with the swivel action.
3. Flush and test the entire system. Be sure to follow the **Flushing Procedure**, page 8.



Operation

NOTICE
<p>The new system must be cleaned and tested thoroughly before admitting fluid to the regulator to avoid contaminants clogging or damaging the regulator.</p> <p>Always use the lowest possible air and fluid pressures for your application. High pressures cause premature spray nozzle and pump wear.</p>

NOTE: Reference numbers and letters in parentheses in the text refer to the Figs. and Parts Drawing.

Pressure Relief Procedure

 Follow the Pressure Relief Procedure whenever you see this symbol.

				
				
<p>This equipment stays pressurized until pressure is manually relieved. To help prevent serious injury from pressurized fluid, such as skin injection, splashing fluid and moving parts, follow the Pressure Relief Procedure when you stop spraying and before cleaning, checking, or servicing the equipment.</p>				

1. Shut off the pump.
2. Close the fluid regulator's inlet ball valve. Refer to FIG. 1 and FIG. 2.
3. Relieve fluid pressure in the fluid regulator by triggering the spray gun.

Flushing Procedure

				
<p>To avoid fire and explosion, always ground equipment and waste container. To avoid static sparking and injury from splashing, always flush at the lowest possible pressure.</p>				

- Flush before changing colors, before fluid can dry in the equipment, at the end of the day, before storing, and before repairing equipment.
 - Flush at the lowest pressure possible. Check connectors for leaks and tighten as necessary.
 - Flush with a fluid that is compatible with the fluid being dispensed and the equipment wetted parts.
1. Record the pressure adjustment setting of the fluid regulator before flushing.
 2. Shut off the pump and relieve fluid pressure in the system by triggering the gun and opening the back pressure regulator or other bypass valve.
 3. Never exceed the maximum working pressure of the lowest rated system component. Remove the gauge if the flushing pressure will exceed the gauge range.
 4. Open the fluid regulator fully.
 - a. *Spring Operated Regulators Only (see FIG. 3)* The regulator can be fully opened in two ways:
 - Using the male end (B) of the regulator key (24), turn the socket-head adjustment screw (19) fully *counterclockwise*. The pressure setting will be retained.
 - Using the female end (A) of the regulator key (24), turn the adjustment screw (12) fully *clockwise*. You will have to reset pressure after flushing.
 - b. *Air Operated Regulator Only.* The regulator can be fully opened in two ways:

- Close the outlet valve at the air regulator and open the air regulator bypass valve, to supply air directly to the fluid regulator; do not exceed the maximum rated air pressure of the fluid regulator. Pressure setting of the fluid regulator will be retained using this method.
 - Increase the air regulator setting to fully open the fluid regulator. You will have to reset the fluid regulator's pressure setting after flushing.
5. Supply solvent to the system. Set pump to the lowest possible pressure, and start pump.
 6. Flush until thoroughly clean.
 7. Adjust the fluid regulator to the desired setting.
 - a. *Spring Operated Regulators Only (see FIG. 3)* The regulator can be adjusted in two ways:
 - Using the male end (B) of the regulator key (24), turn the socket-head adjustment screw (19) fully *clockwise*. Verify that the pressure setting has not changed.
 - Using the female end (A) of the regulator key (24), turn the adjustment screw (12) *counterclockwise* to return to the desired pressure setting.
 - b. *Air Operated Regulator Only.* The regulator can be adjusted in two ways:
 - Close the air regulator bypass valve and open the outlet valve at the air regulator. Verify that the pressure setting has not changed.
 - Adjust the air regulator to return to the desired fluid pressure setting.

Regulating Fluid Pressure

Spring Operated Regulator

1. Close the regulator: engage the female end (A) of the key (24) with the adjusting screw (12) and turn it counterclockwise to relieve the spring tension. See FIG. 3.
2. Start the pump and open the fluid regulator's inlet ball valve to admit fluid to the regulator. See FIG. 1.
3. Turn the key (24) *clockwise* to increase fluid pressure. See FIG. 3. Adjust for the desired spray pattern.

NOTE: If using a fluid pressure gauge, reduce the regulator pressure before partially relieving pressure in the gun hose, to ensure a correct gauge reading. Then increase regulator pressure to the desired setting.

Air Operated Regulator

1. Start the pump and open the fluid regulator's inlet ball valve to admit fluid to the regulator. See FIG. 2.
2. Increase the air pressure to obtain the desired fluid pressure. Adjust for the desired spray pattern.

NOTE: If using a fluid pressure gauge, reduce the regulator pressure before partially relieving pressure in the gun hose, to ensure a correct gauge reading. Then increase regulator pressure to the desired setting.

NOTE: Make sure the air bleed hole in the air line fitting (29) is not plugged. Refer to page 11.

For the best results, use an air regulator with at least a 2 in. (51 mm) diameter diaphragm to control this fluid regulator.

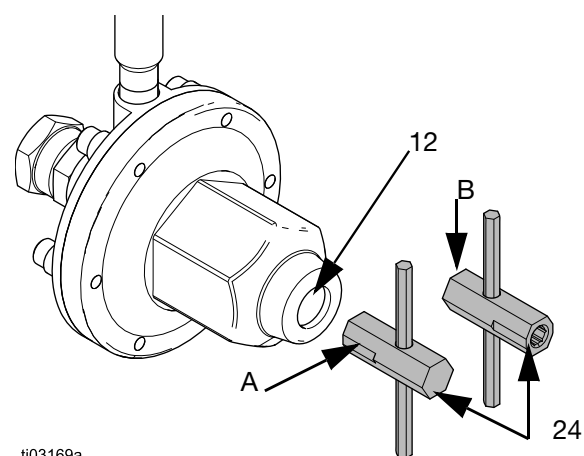

ti03169a
FIG. 3

Troubleshooting

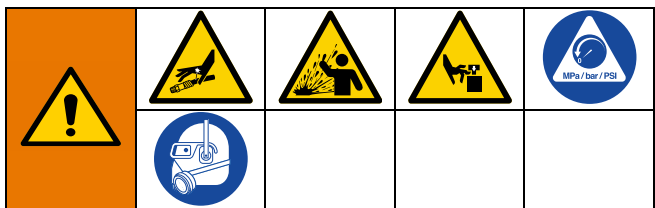

Before servicing this equipment always make sure to Relieve the Pressure. Follow **Pressure Relief Procedure**, page 8.

Check all possible remedies in the Troubleshooting Chart before disassembling the fluid regulator.

Problem	Cause	Solution
No pressure regulation	Damaged or clogged air regulator or line (214980 only)	Clear obstruction in line, service regulator if necessary.
	Damaged diaphragm (22)	Replace diaphragm.
Fluid leaks from under cap	Loose cap (7)	Tighten screws (1) in sequence shown in Service section.
	Worn gasket (26)	Replace gasket.
Pressure creeps above setting	Damaged or clogged air regulator or line (214980 only)	Clear obstruction in line, service regulator if necessary.
	Damaged diaphragm (22)	Replace diaphragm.
	Seat leaking (16)	Replace ball (20), seat, and gasket (15).
Pressure drops below setting	Damaged or clogged air regulator or line (214980 only)	Clear obstruction in line, service regulator if necessary.
	Empty/clogged supply line	Fill/flush supply line.
	Clogged air spray gun or fluid dispensing valve.	Replace, see gun or valve manual for service instructions.
	Using regulator beyond its rated flow capacity, see the Technical Data , page 22.	Install additional regulators.

Service

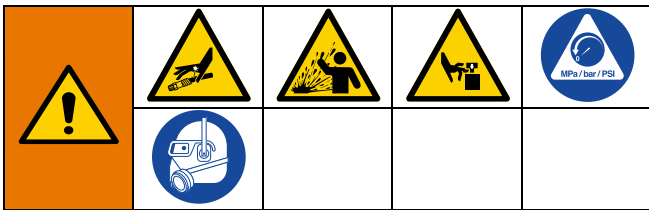

Service of the Air Operated Regulators

1. Follow **Pressure Relief Procedure**, page 8.
2. Shut off the pump.
3. Close the ball valve at the regulator's air inlet. Refer to FIG. 2.
4. Release all the air and fluid pressure in the regulator and disconnect the air and fluid lines.
5. Remove the regulator from the system.
6. Remove the swivel union (23) and spring (40) from the regulator body.
7. Remove the ball (20), seat (16), and gasket (15). See FIG. 4.

NOTICE

Use special care when handling the hard carbide ball (20) and seat (16) to avoid damaging them.

NOTE: Gasket (15) is thin and translucent. Be sure to remove the gasket.

8. Remove the six cap screws (1) and housing (6).
9. Place diaphragm assembly in a vise, with jaws on stem housing (18). Remove the retaining screw (10),

jam nut (13) and washer (17) from the stem housing (18).

10. Remove the diaphragm (22) and gasket (26).
11. Remove the spring (3), valve stem (9), and gasket (21) from the stem housing (18).
12. Thoroughly clean and inspect all parts. Replace any parts that appear to be worn or damaged.
13. Place stem housing (18) in a vise. One at a time, place the gasket (26), diaphragm (22) - *white PTFE side down toward the bottom housing*, and washer (17) on the stem housing (18). Secure them with the jam nut (13). Torque the jam nut onto the stem housing to 21-35 ft-lb (28-47 N•m).
14. Install the valve stem (9), spring (3), gasket (21), and retaining screw (10) in the stem housing (18). Make sure the tab on the valve stem (9) fits into the slot on screw (10).
15. Torque the retaining screw into the housing to 21-25 ft-lb (28-34 N•m).
16. Install the assembled parts in the housing (6).
17. On Model 214980, tighten the air line fitting (29) into the cap (7). Torque to 20-25 ft-lb (27-34 N•m).
18. Install the cap (7). Tighten the six cap screws (1) in the sequence shown in FIG. 4, Bottom View, and to the torque noted.
19. Install the gasket (15), valve seat (16), and ball (20) into the housing (6).

NOTE: Seat may be turned upside down and reused

20. Screw the swivel union (23), with the o-ring (4) attached and the spring (40) in place, into the inlet. Torque to 23-27 ft-lb (31-36 N•m).

Models 214980 (shown) & 244375

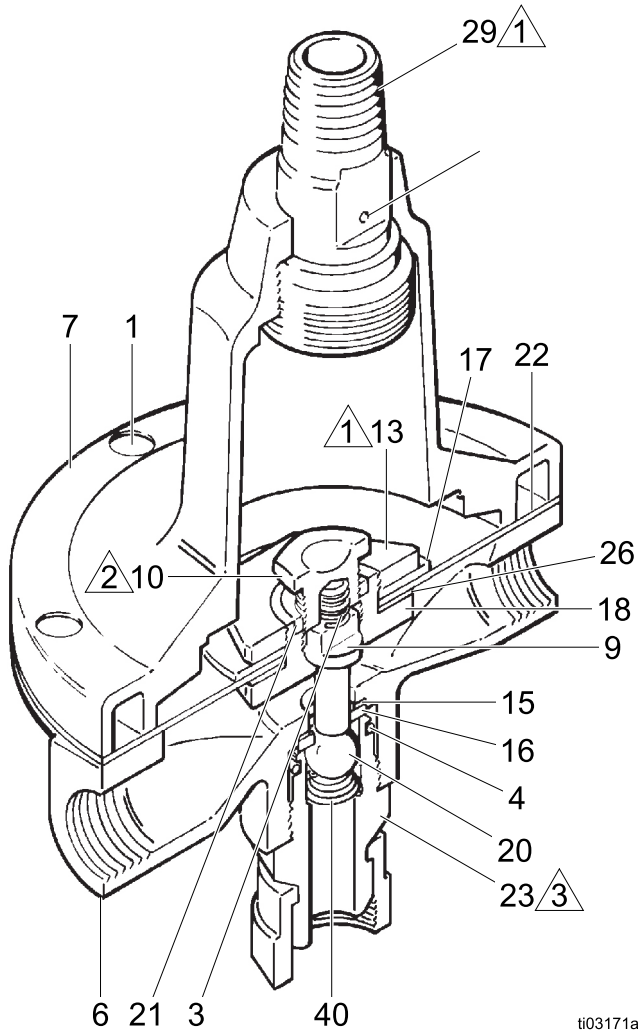

1 Torque to 20-25 ft-lb (27-34 N•m)

2 Torque to 21-25 ft-lb (28-34 N•m)

3 Torque to 23-27 ft-lb (31-36 N•m)

NOTE: Numbers indicate tightening sequence. Tighten evenly to 7-10 in-lb (0.8-1.1 N•m), then retorque to 125 in-lb (14 N•m) three times, consecutively, to compensate for diaphragm relaxation.

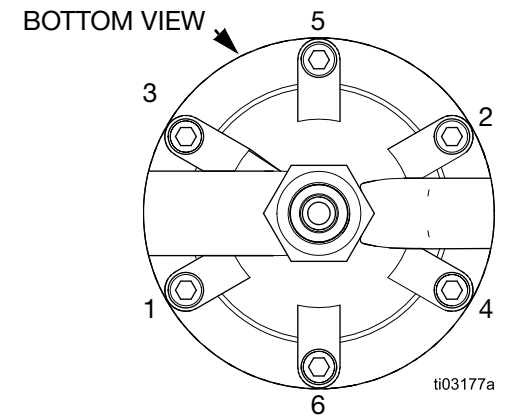
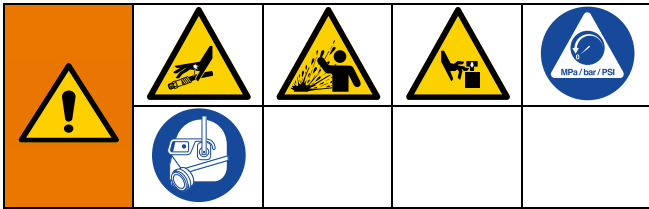

FIG. 4:

Service of the Spring Operated Regulators



1. Follow **Pressure Relief Procedure**, page 8.
2. Shut off the pump.
3. Close the ball valve at the regulator's fluid inlet. See FIG. 1.
4. Release all fluid pressure in the regulator and disconnect the fluid line.
5. Remove the regulator from the system.
6. Remove the swivel union (23) and spring (40) from the regulator body.
7. Remove the ball (20), valve seat (16), and gasket (15). See FIG. 5.

NOTICE

Use special care when handling the hard carbide ball (20) and seat (16) to avoid damaging them.

- NOTE:** Gasket (15) is thin and translucent. Be sure to remove the gasket.
8. Remove the six cap screws (1) and housing (6).
 9. Remove the cap (7), adjusting screw (12) and spring (5).
 10. Place diaphragm assembly in a vise, with jaws on stem housing (18). Remove the stem retaining screw (10), jam nut (13), and washer (17) from the stem housing (18).

11. Remove the diaphragm (25) - *on Models 217314 and 221118 only*, diaphragm (22), and gasket (26).
12. Remove the spring (3), valve stem (9) and gasket (21) from the stem housing.
13. Thoroughly clean and inspect all parts. Replace any parts that appear to be worn or damaged.
14. Place stem housing (18) in a vise. One at a time, place the gasket (26), diaphragm (22) - *white PTFE side down toward bottom housing*, diaphragm (25) - *on Models 217314 and 221118 only*, and washer (17) on the stem housing (18). Secure them with the jam nut (13).

NOTE: *On Models 217314 and 221118*, align the holes on the diaphragms (25 & 22) before tightening the jam nut (13).

15. Torque the jam nut (13) onto the stem housing (18) to 21 -35 ft-lb (28 -47 N•m).
 16. Install the valve stem (9), spring (3), gasket (21) and retaining screw (10) in the stem housing (18). Make sure the tab on the valve stem (9) fits into the slot on screw (10).
 17. Torque the retaining screw (10) into the housing to 21 -25 ft-lb (28 -34 N•m).
 18. Install the spring, adjusting screw (12) and cap on the housing (6). Tighten six capscrews (1) in the sequence shown in FIG. 5, **Bottom View**, and to the torque noted.
 19. Install the gasket (15), valve seat (16), and ball (20) into the housing (6).
- NOTE:** Seat may be turned upside down and reused.
20. Screw the swivel union (23), with the o-ring (4) attached and the spring (40) in place, into the inlet. Torque to 23 -27 ft-lb (31 -36 N•m).

Models 217314 and 221118

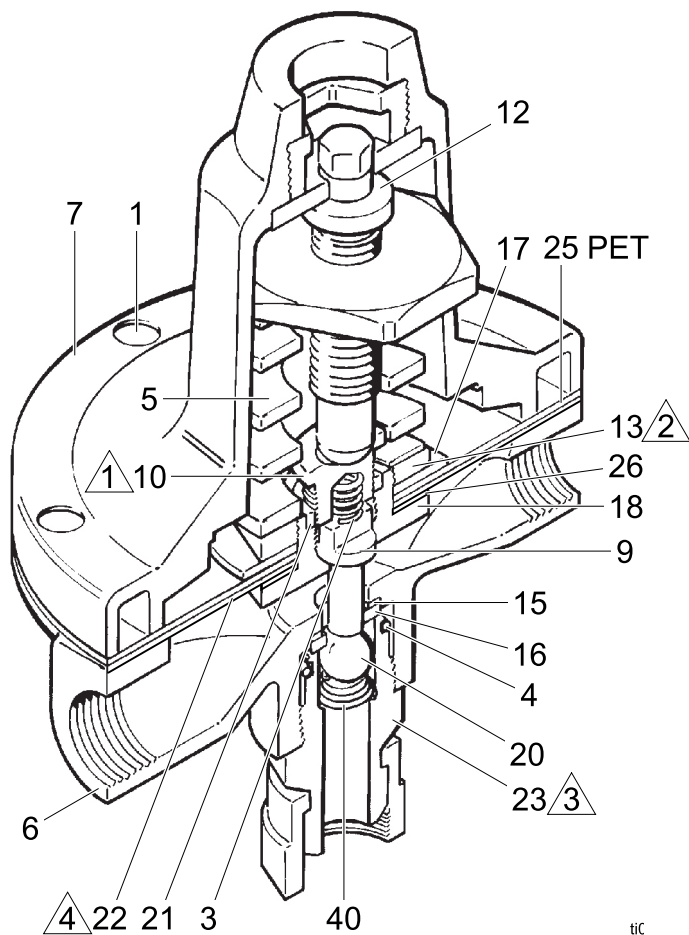

- △ 1 Torque to 21 -25 ft-lb (28-34 N•m)
- △ 2 Torque to 21 -35 ft-lb (28-47 N•m)
- △ 3 Torque to 23 -27 ft-lb (31 -36 N•m)
- △ 4 PTFE side down toward housing (6)

Models 214895, 214706, 26C160, and 24A082

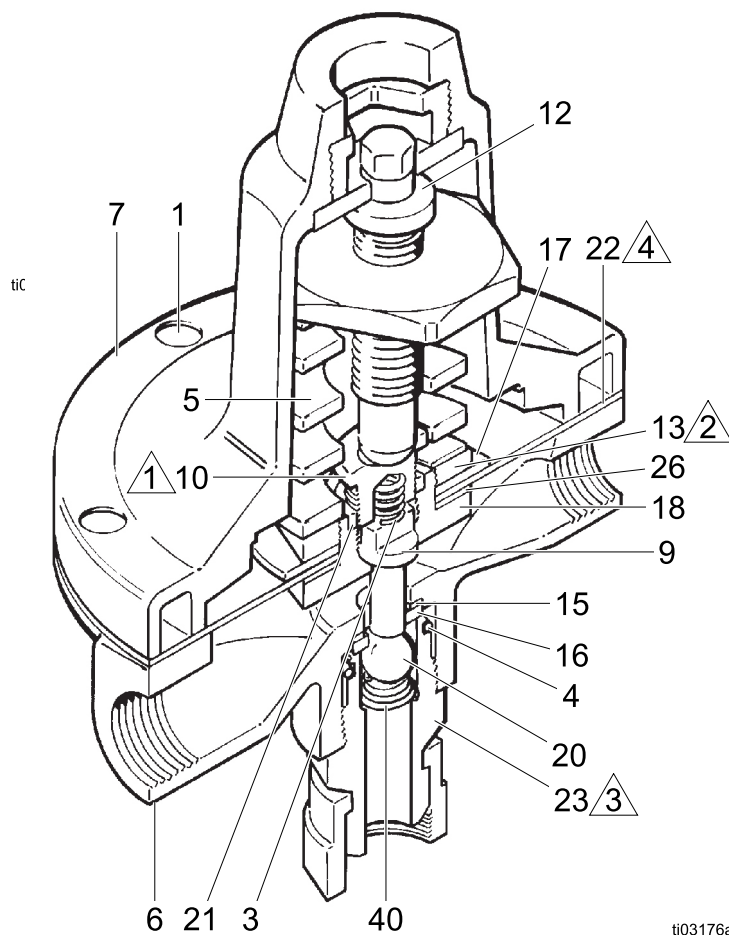

NOTE: Numbers indicate tightening sequence. Tighten evenly to 7 -10 in-lb (0.8 -1.1 N•m), then retorque to 125 in-lb (14 N•m) three times, consecutively, to compensate for diaphragm relaxation.

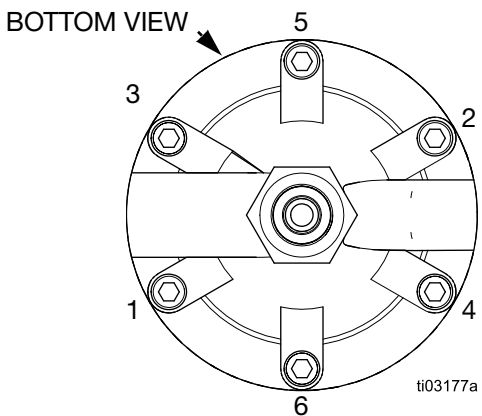

FIG. 5

Parts

Model 214895, Series H

Without gauge. Includes items 1 -26, 4

Model 214706, Series H

With gauge. Includes items 1 -40

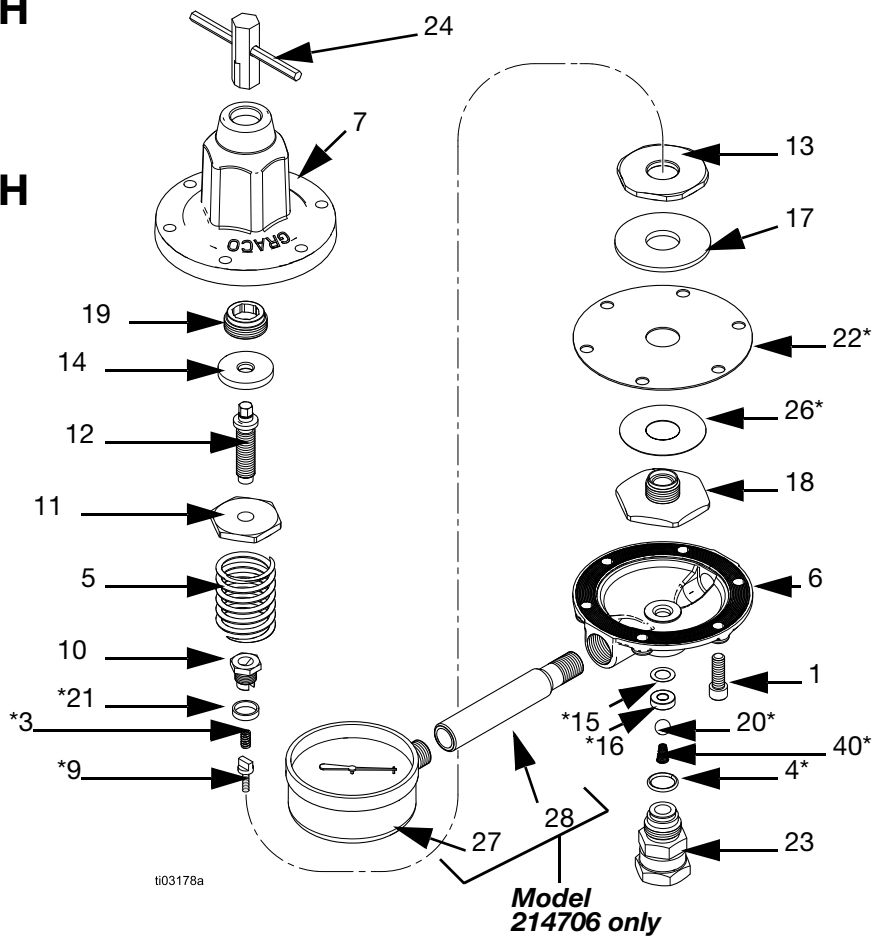

Fig. 6: Model 214706

Ref No.	Part No.	Description	Qty	Ref No.	Part No.	Description	Qty
1	100644	SCREW, soc hd cap; 0.25" -20 x 0.75"	6	18	187879	HOUSING, stem	1
3	111736*	SPRING, compression	1	19	176136	SCREW, adjustment	1
4	104319*	O-RING, PTFE	1	20	112365*	BALL; tungsten carbide	1
5	105291	SPRING, compression	1	21	171867*	GASKET	1
6	187880	HOUSING; stainless steel	1	22	171868*	DIAPHRAGM; PTFE with nylon fabric/Buna-N base	1
7	176135	CAP, regulator	1	23	235209	UNION, swivel; 3/8 npsm	1
9	187851*	STEM, valve	1	24	215393	KEY, regulator	1
10	188004	SCREW, retaining	1	26	172132*	GASKET; cellulose fibre	1
11	171855	NUT, adjustment	1	27	187874	GAUGE, pressure; stainless steel; 100 psi (0.7 MPa, 7 bar) (214706 only)	1
12	176691	SCREW, adjustment	1	28	187877	TUBE, riser (214706 only)	1
13	171858	NUT, jam; special	1	40	111858*	SPRING, compression	1
14	176692	WASHER, flat	1				
15	171860*	GASKET, seat	1				
16	15V292*	SEAT, valve; tungsten carbide	1				
17	171862	WASHER, diaphragm	1				

* Included in Repair Kit 222651.

Model 26C160, Series A Model 24A082, Series A

ISO pitch thread inlet and outlet
(Not compatible with US standard pitch. On model 24A082 only, fluid housing is coated with PTFE based polymer.)

Includes items 1 -40

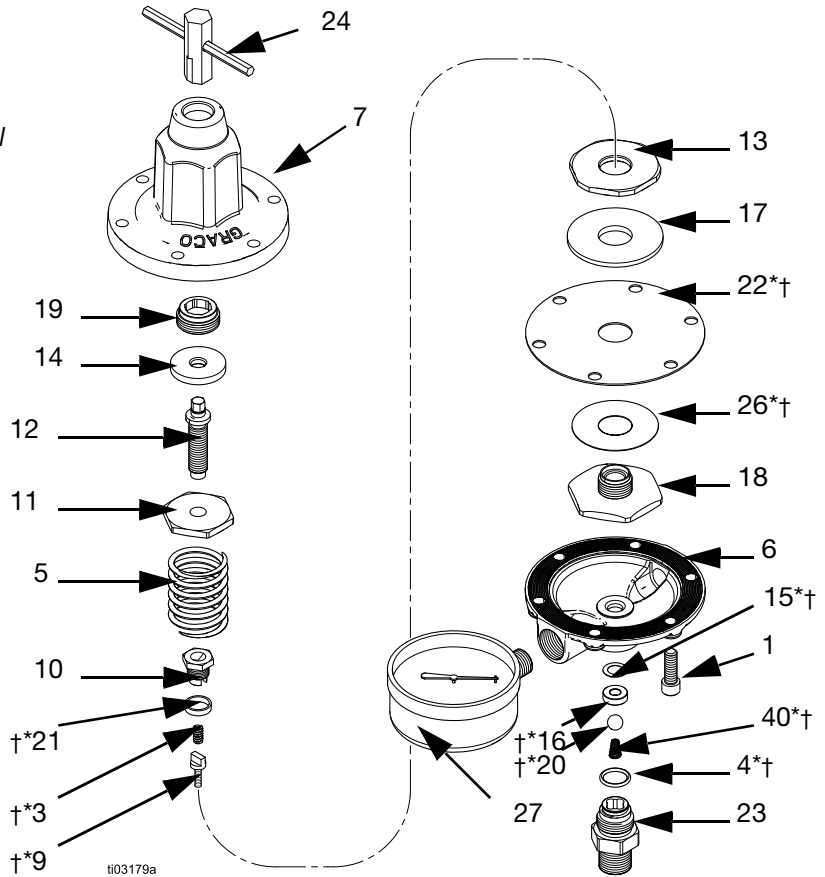

FIG. 7

Ref No.	Part No.	Description	Qty	Ref No.	Part No.	Description	Qty
1	100644	SCREW, soc hd cap; 0.25" -20 x 0.75"	1	16	15V292*	SEAT, valve; tungsten carbide	1
3	111736*†	SPRING, compression	1	17	171862	WASHER, diaphragm	1
4	104319*†	O-RING, PTFE	1	18	187879	HOUSING, stem	1
5	105291	SPRING, compression	1	19	176136	SCREW, adjustment	1
6	195935	HOUSING; stainless steel w/PTFE coating 3/8 - 19, ISO female outlet (24A082 only)	1	20	112365*†	BALL; tungsten carbide	1
	17V349	HOUSING; stainless steel 3/8 - 19, ISO female outlet (no PTFE coating, 26C160 only)	1	21	171867*†	GASKET	1
7	176135	CAP, regulator	1	22	171868	DIAPHRAGM; PTFE with nylon fabric/Buna-N base	1
9	187851*†	STEM, valve	1	23	195934	ADAPTER, inlet; 3/8 - 19, ISO male inlet	1
10	188004	SCREW, retaining	1	24	215393	KEY, regulator	1
11	171855	NUT, adjustment	1	26	172132*†	GASKET; cellulose fibre	1
12	176691	SCREW, adjustment	1	27	-187874/ ^187873	GAUGE, pressure; stainless steel; 100 psi (0.7 MPa, 7 bar)	1
13	171858	NUT, jam; special	1	40	111858*†	SPRING, compression	1
14	176692	WASHER, flat	1				
15	171860*†	GASKET, seat	1				

* Included in Repair Kit 222651.
† Included in Repair Kit 273024 (for solvent or thin material).
- Used with 24A082
^ Used with 26C160

Model 217314, Series F

With gauge. Includes items 1-32, 40

Model 221118, Series E

Without gauge. Includes items 1-26, 32-40

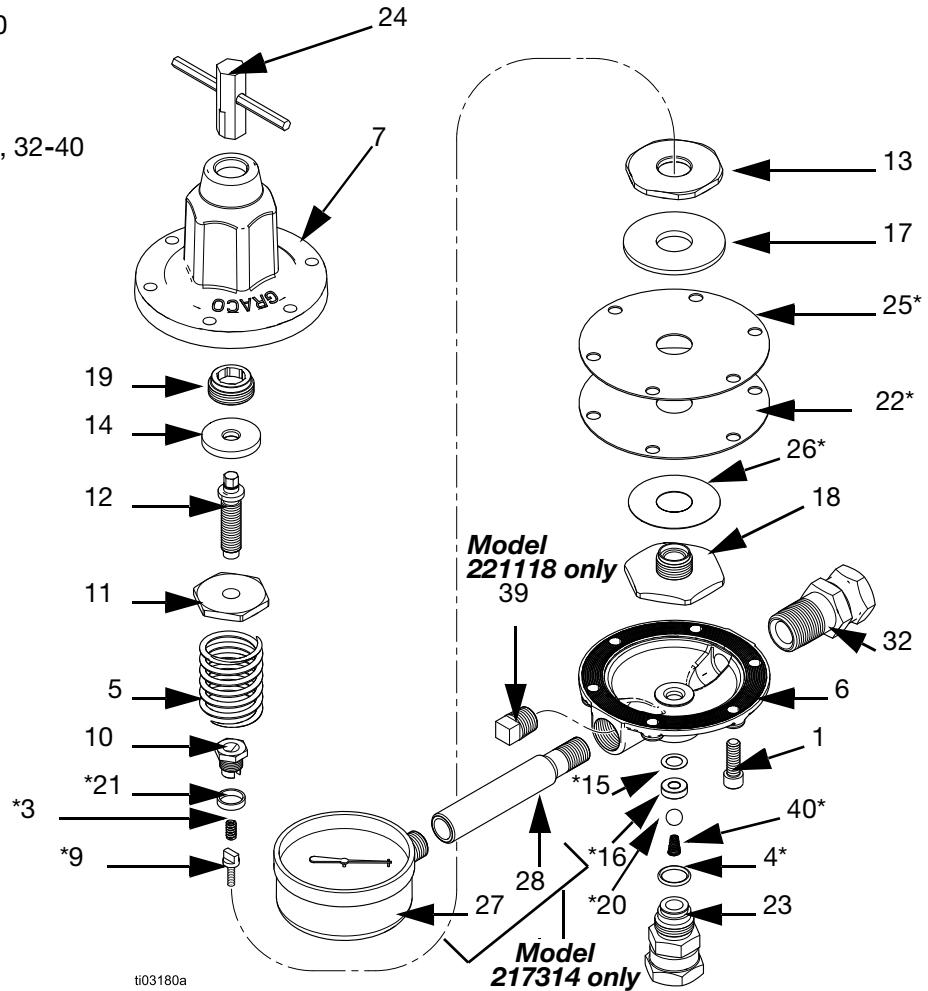

FIG. 1

Ref No.	Parts No.	Description	Qty	Ref No.	Parts No.	Description	Qty
1	100644	SCREW, soc hd cap; 0.25" -20 x 0.75"	6	19	176136	SCREW, adjustment	1
3	111736*	SPRING, compression	1	20	112365*	BALL; tungsten carbide	1
4	104319*	O-RING, PTFE	1	21	171867*	GASKET	1
5	106480	SPRING, compression	1	22	180052*	DIAPHRAGM; PTFE	1
6	187880	HOUSING; stainless steel	1	23	235209	UNION, swivel; 3/8 npsm	1
7	176135	CAP, regulator	1	24	215393	KEY, regulator	1
9	187851*	STEM, valve	1	25	180051*	DIAPHRAGM, PET	1
10	188004	SCREW, retaining	1	26	172132*	GASKET; cellulose fibre	1
11	171855	NUT, adjustment	1	27	187876	GAUGE, pressure; stainless steel; 300 psi (2.1 MPa, 21 bar) (217314 only)	1
12	176691	SCREW, adjustment	1	28	187877	TUBE, riser (217314 only)	1
13	171858	NUT, jam; special	1	32	235207	ADAPTER, straight union; 3/8 npsm	1
14	176692	WASHER, flat	1	39	111697	PLUG, pipe; 1/4 npt(m); (221118 only)	1
15	171860*	GASKET, seat	1	40	111858*	SPRING, compression	1
16	15V292*	SEAT, valve; tungsten carbide	1				
17	171862	WASHER, diaphragm	1				
18	187879	HOUSING, stem	1				

* Included in Repair Kit 222652.

Model 214980 Series F

Includes item 1-40

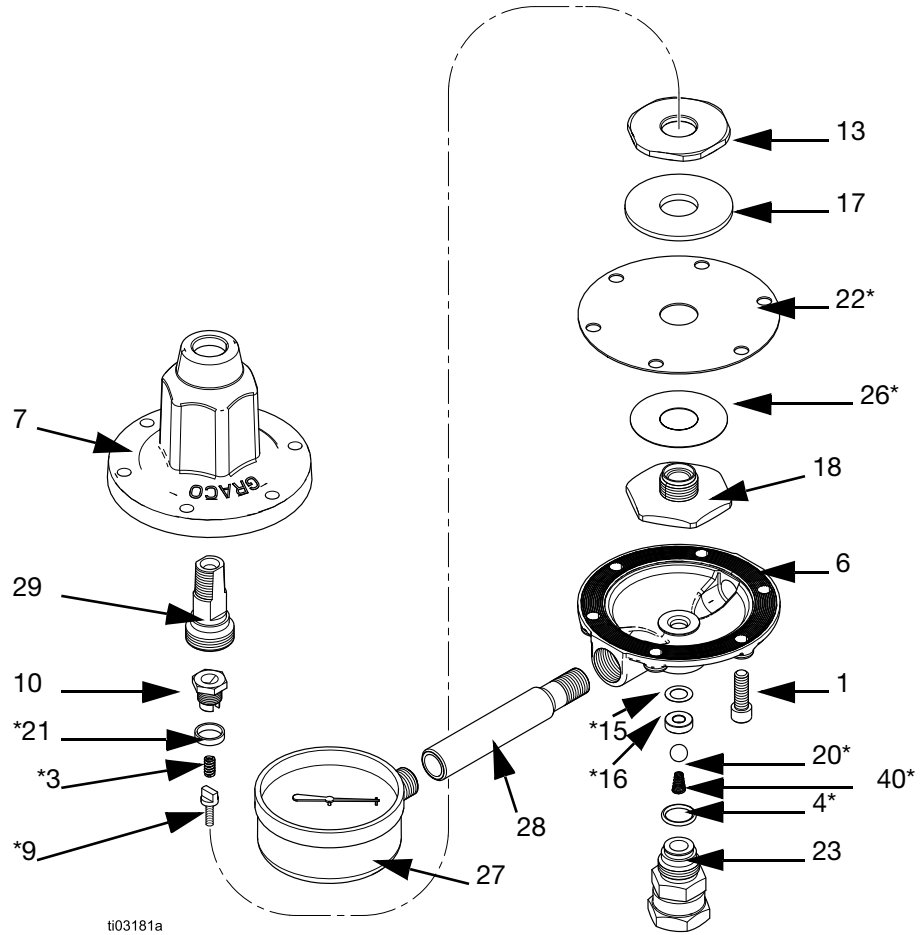

ti03181a

FIG. 8

Ref No.	Parts No.	Description	Qty	Ref No.	Parts No.	Description	Qty
1	100644	SCREW, soc hd cap; 0.25" -20 x 0.75"	6	22	171868*	DIAPHRAGM; PTFE with nylon fabric/Buna-N base	1
3	111736*	SPRING, compression	1	23	235209	UNION, swivel; 3/8 npsm	1
4	104319*	O-RING, PTFE	1	26	172132*	GASKET; cellulose fibre	1
6	187880	HOUSING; stainless steel	1	27	187875	GAUGE, pressure; stainless steel; 30 psi (21 kPa, 2.1 bar)	1
7	176135	CAP, regulator	1	28	187877	TUBE, riser	1
9	187851*	STEM, valve	1	29	176463	FITTING, air line	1
10	188004	SCREW, retaining	1	40	111858*	SPRING, compression	1
13	171858	NUT, jam; special	1				
15	171860*	GASKET, seat	1				
16	15V292*	SEAT, valve; tungsten carbide	1				
17	171862	WASHER, diaphragm	1				
18	187879	HOUSING, stem	1				
20	112365*	BALL; tungsten carbide	1				
21	171867*	GASKET	1				

* Included in Repair Kit 222651

Model 244375 Series B

Includes item 1-41

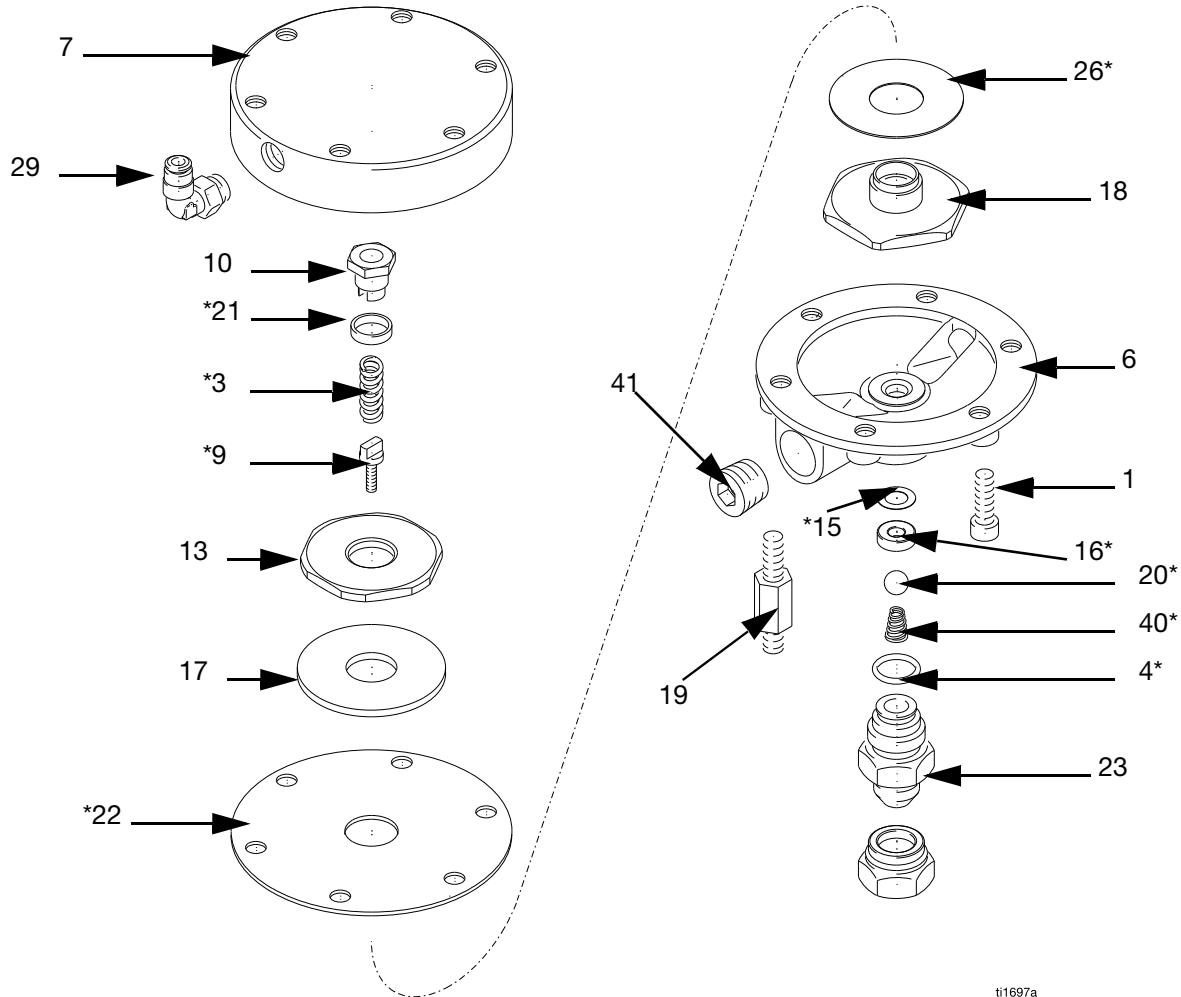

ti1697a

Fig. 9

Ref No.	Part No.	Description	Qty	Ref No.	Part No.	Description	Qty
1	100644	SCREW, soc hd cap; 0.25" -20 x 0.75"	4	19	197213	STUD, mounting	1
3	111736*	SPRING, compression	1	20	112365*	BALL; tungsten carbide	2
4	104319*	O-RING, PTFE	1	21	171867*	GASKET	1
6	187880	HOUSING; stainless steel	1	22	171868*	DIAPHRAGM; PTFE with nylon fabric/Buna-N base	1
7	833166	CAP, regulator	1	23	235209	UNION, swivel; 3/8 npsm	1
9	187851*	STEM, valve	1	26	172132*	GASKET; cellulose fibre	1
10	188004	SCREW, retaining	1	29	114151	FITTING, air line	1
13	171858	NUT, jam; special	1	40	111858*	SPRING, compression	1
15	171860*	GASKET, seat	1	41	101748	PLUG, pipe	1
16	15V292*	SEAT, valve; tungsten carbide	1				
17	171862	WASHER, diaphragm	1				
18	187879	HOUSING, stem	1				

* Included in Repair Kit 222651.

Dimensions

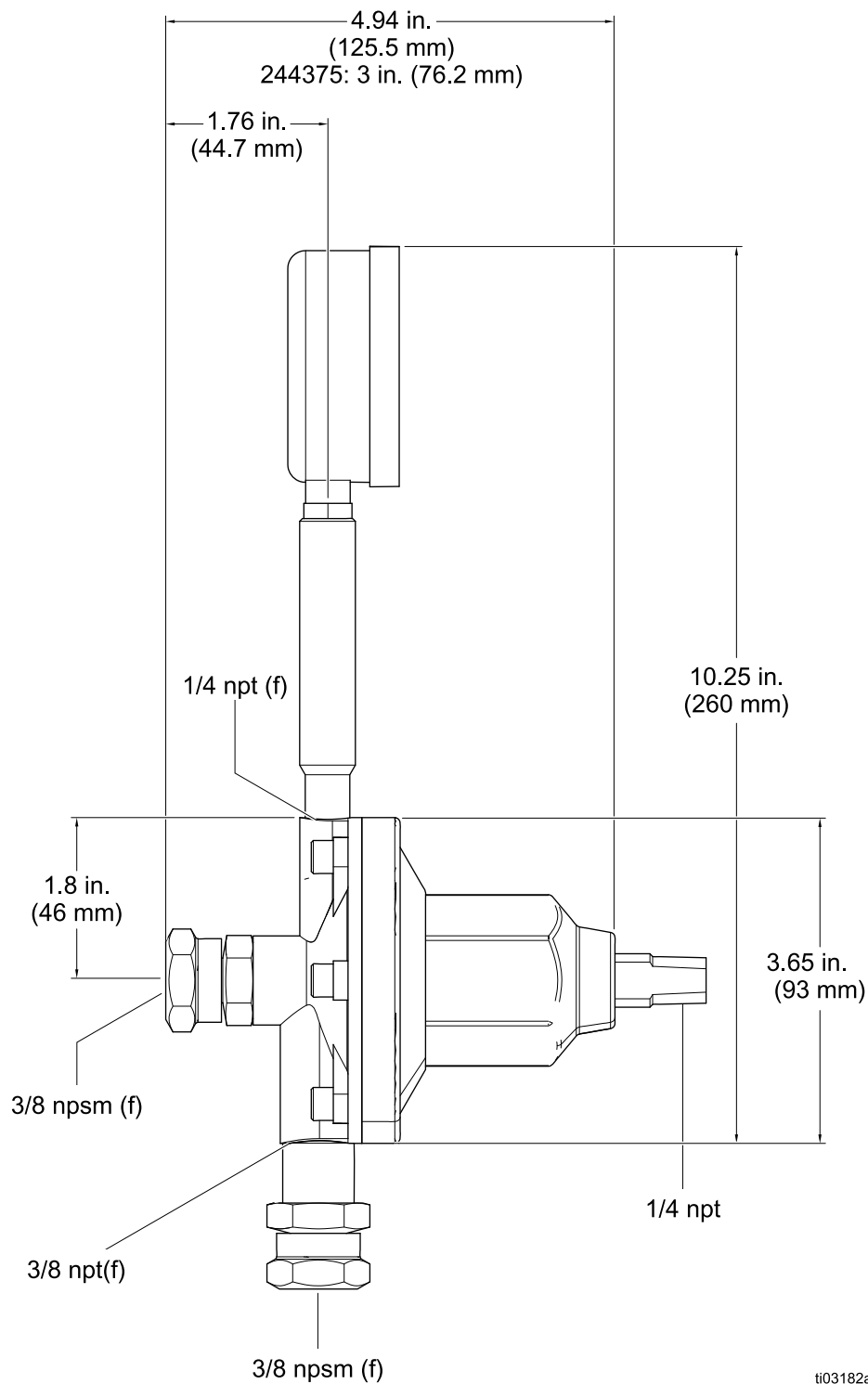

FIG. 10

Technical Data

Category	Data
Maximum Fluid Inlet Pressure	250 psi (1.8 MPa, 18 bar)
Regulated Fluid Pressure Range	<p><i>Models 217314 & 221118:</i> 20 -160 psi (0.15 -1.1 MPa, 1.5 -11 bar)</p> <p><i>Models 214706, 214895, 244375, 26C160, & 24A082:</i> 5 -100 psi (30 -700 kPa, 0.3 -7.0 bar)</p> <p><i>Model 214980:</i> 0 -30 psi (0 -210 kPa, 0 -2 bar)</p>
Maximum Flow Capacity	3 gpm (11 liters/min) with 70 cps fluid at 200 psi (1.4 MPa, 14 bar) inbound pressure
Wetted Parts	Tungsten Carbide, Acetal Resins, PTFE, 304 & 316 Series Stainless Steel, Nylon, PET.
Canadian Registration Number (CRN): Alberta - 0C04874.52 Ontario - 0C4874.5R1	Models: 214895, 214706, 217314, 221118, and 214980

Performance Chart

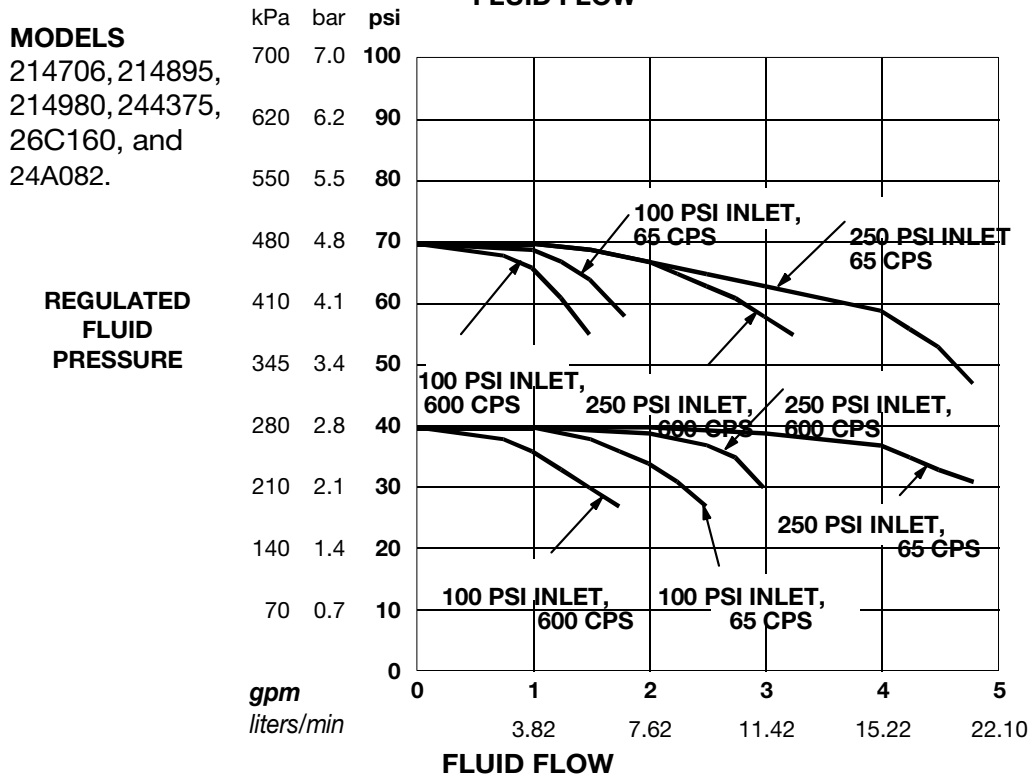
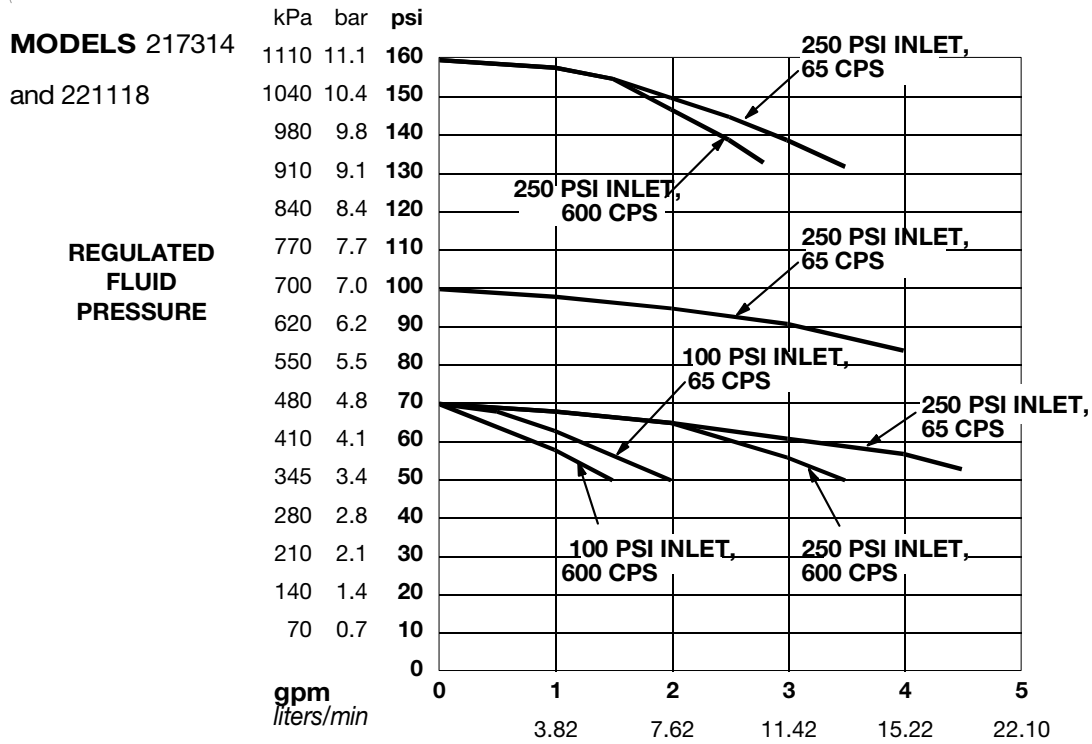

FIG. 11

Graco Standard Warranty

Graco warrants all equipment referenced in this document which is manufactured by Graco and bearing its name to be free from defects in material and workmanship on the date of sale to the original purchaser for use. With the exception of any special, extended, or limited warranty published by Graco, Graco will, for a period of twelve months from the date of sale, repair or replace any part of the equipment determined by Graco to be defective. This warranty applies only when the equipment is installed, operated and maintained in accordance with Graco's written recommendations.

This warranty does not cover, and Graco shall not be liable for general wear and tear, or any malfunction, damage or wear caused by faulty installation, misapplication, abrasion, corrosion, inadequate or improper maintenance, negligence, accident, tampering, or substitution of non-Graco component parts. Nor shall Graco be liable for malfunction, damage or wear caused by the incompatibility of Graco equipment with structures, accessories, equipment or materials not supplied by Graco, or the improper design, manufacture, installation, operation or maintenance of structures, accessories, equipment or materials not supplied by Graco.

This warranty is conditioned upon the prepaid return of the equipment claimed to be defective to an authorized Graco distributor for verification of the claimed defect. If the claimed defect is verified, Graco will repair or replace free of charge any defective parts. The equipment will be returned to the original purchaser transportation prepaid. If inspection of the equipment does not disclose any defect in material or workmanship, repairs will be made at a reasonable charge, which charges may include the costs of parts, labor, and transportation.

THIS WARRANTY IS EXCLUSIVE, AND IS IN LIEU OF ANY OTHER WARRANTIES, EXPRESS OR IMPLIED, INCLUDING BUT NOT LIMITED TO WARRANTY OF MERCHANTABILITY OR WARRANTY OF FITNESS FOR A PARTICULAR PURPOSE.

Graco's sole obligation and buyer's sole remedy for any breach of warranty shall be as set forth above. The buyer agrees that no other remedy (including, but not limited to, incidental or consequential damages for lost profits, lost sales, injury to person or property, or any other incidental or consequential loss) shall be available. Any action for breach of warranty must be brought within two (2) years of the date of sale.

GRACO MAKES NO WARRANTY, AND DISCLAIMS ALL IMPLIED WARRANTIES OF MERCHANTABILITY AND FITNESS FOR A PARTICULAR PURPOSE, IN CONNECTION WITH ACCESSORIES, EQUIPMENT, MATERIALS OR COMPONENTS SOLD BUT NOT MANUFACTURED BY GRACO. These items sold, but not manufactured by Graco (such as electric motors, switches, hose, etc.), are subject to the warranty, if any, of their manufacturer. Graco will provide purchaser with reasonable assistance in making any claim for breach of these warranties.

In no event will Graco be liable for indirect, incidental, special or consequential damages resulting from Graco supplying equipment hereunder, or the furnishing, performance, or use of any products or other goods sold hereto, whether due to a breach of contract, breach of warranty, the negligence of Graco, or otherwise.

FOR GRACO CANADA CUSTOMERS

The Parties acknowledge that they have required that the present document, as well as all documents, notices and legal proceedings entered into, given or instituted pursuant hereto or relating directly or indirectly hereto, be drawn up in English. Les parties reconnaissent avoir convenu que la rédaction du présente document sera en Anglais, ainsi que tous documents, avis et procédures judiciaires exécutés, donnés ou intentés, à la suite de ou en rapport, directement ou indirectement, avec les procédures concernées.

Graco Information

For the latest information about Graco products, visit www.graco.com.

For patent information, see www.graco.com/patents.

TO PLACE AN ORDER, contact your Graco distributor or call to identify the nearest distributor.

Toll Free Phone Number: 1-800-328-0211

All written and visual data contained in this document reflects the latest product information available at the time of publication. Graco reserves the right to make changes at any time without notice.

Original instructions. This manual contains English. MM

Graco Headquarters: Minneapolis

International Offices: Belgium, China, Japan, Korea

GRACO INC. AND SUBSIDIARIES • P.O. BOX 1441 • MINNEAPOLIS MN 55440-1441 • USA
Copyright 2023, Graco Inc. All Graco manufacturing locations are registered to ISO 9001.

www.graco.com
Revision ZAK, March 2025