

INSTRUCTIONS—PARTS LIST



307-605

Rev P
Supersedes N

This manual contains IMPORTANT
WARNINGS AND INSTRUCTIONS
READ AND RETAIN FOR REFERENCE

King®, Bulldog®, and Senator® Pump, with Priming Piston and
Ultra-High Molecular Weight Polyethylene and PTFE Packings

POWER-FLO PUMPS

15:1 RATIO SENATOR PUMP

105 bar (1500 psi) MAXIMUM WORKING PRESSURE

Model 222-489, Series A

200 liter (55 gallon) drum size, Standard Air Motor

25:1 RATIO BULLDOG PUMPS

175 bar (2500 psi) MAXIMUM WORKING PRESSURE

Model 217-565, Series A

200 liter (55 gallon) drum size, Standard Air Motor

Model 222-228, Series A

200 liter (55 gallon) drum size, Quiet Air Motor

Model 217-564, Series D

19 liter (5 gallon) ram size, Standard Air Motor

25:1 RATIO SENATOR PUMP

175 bar (2500 psi) MAXIMUM WORKING PRESSURE

Model 222-519, Series A

200 liter (55 gallon) drum size, Standard Air Motor

40:1 RATIO BULLDOG PUMPS

280 bar (4000 psi) MAXIMUM WORKING PRESSURE

Model 220-448, Series A

200 liter (55 gallon) drum size, Standard Air Motor

Model 220-447, Series A

19 liter (5 gallon) ram size, Standard Air Motor

55:1 RATIO KING PUMPS

345 bar (5000 psi) MAXIMUM WORKING PRESSURE

Model 217-566, Series A

200 liter (55 gallon) drum size, Standard Air Motor

Model 222-229, Series A

200 liter (55 gallon) drum size, Quiet Air Motor

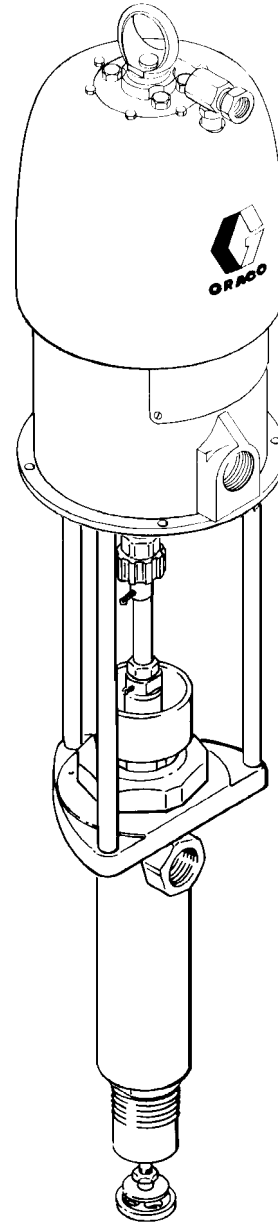

Table of Contents on page 3

Model 220-448 shown



THIS PAGE IS BLANK

TABLE OF CONTENTS

Terms	3
Warnings	4, 5
Installation	6
Operation	7
Maintenance	8
Troubleshooting Guide	8, 9
Displacement Pump Service	10–13
Parts Lists And Drawings	
15:1 Senator, 25:1 Ratio Bulldog, and 55:1 Ratio King Pumps	14, 15
25:1 Senator and 40:1 Ratio Bulldog Pumps	16, 17
Accessories	18–20
Technical Data And Performance Charts	
15:1 Ratio Senator Pump	21
25:1 Ratio Senator Pump	22
25:1 Ratio Bulldog Pumps	23
40:1 Ratio Bulldog Pumps	24
55:1 Ratio King Pumps	25
Dimensional Drawing	26
Air Motor Mounting Layout	26
Warranty	Back Cover

TERMS

Be sure you read and understand each of these terms before reading the rest of the manual.

WARNING Alerts user to avoid or correct conditions which could cause bodily injury.

CAUTION Alerts user to avoid or correct conditions which could cause damage to or destruction of equipment.

NOTE Gives additional explanation of a procedure or helpful hints.

PRESSURE RELIEF PROCEDURE A safety procedure for relieving air and fluid pressure in the system.

FLUID INJECTION INJURY A serious injury, which may appear to be a simple cut, caused by the high pressure injection of fluid directly into the body.

FLUID Any chemical, such as paint, water, sealant, stain, lacquer, solvents, etc., which is used in the spray or dispensing equipment.

SPRAY GUN/DISPENSING VALVE A device used for controlling the flow of fluid at the end of the outlet hose, which can be triggered on and off and generally has a spray tip (spray guns) or nozzle (dispensing valve). *In this manual, the term spray gun will be used to represent both devices.*

SPRAY GUN SAFETY LATCH A device on the spray gun or dispensing valve which can be secured to prevent dispensing fluid through the gun or valve.

SAFETY WARNINGS

HIGH PRESSURE FLUID CAN CAUSE SERIOUS INJURY. FOR PROFESSIONAL USE ONLY.

OBSERVE ALL WARNINGS. Read And Understand All Instruction Manuals Before Operating Equipment.

MOVING PARTS HAZARD

KEEP HANDS AND FINGERS AWAY FROM THE PRIMING PISTON DURING OPERATION AND WHENEVER THE PUMP IS CHARGED WITH AIR to reduce the risk of injury! On the pump downstroke the priming piston extends beyond the intake cylinder to pull the material into the pump. The priming piston works under extreme force. During operation and whenever the pump is charged with air, the priming piston can severely injure or amputate a hand or finger, or break a tool, caught between it and the intake cylinder. Always follow the **Pressure Relief Procedure**, below, before checking, clearing, cleaning, flushing or servicing any part of the pump.

The air motor piston (located behind the air motor shield) also moves when air is supplied to the motor. NEVER operate the pump with the air motor shield removed. Before servicing the pump, follow the **Pressure Relief Procedure** below to prevent the pump from starting accidentally.

FLUID INJECTION HAZARD

General Safety

This equipment conducts very high fluid pressure. Spray from the spray gun, leaks or ruptured components can inject fluid through your skin and into your body and cause extremely serious bodily injury, including the need for amputation. Also, fluid injected or splashed into the eyes or on the skin can cause serious damage.

NEVER point the spray gun at anyone or at any part of the body. NEVER put hand or fingers over the spray tip.

ALWAYS follow the **Pressure Relief Procedure**, right, before cleaning or removing the spray tip or servicing any system equipment.

NEVER try to stop or deflect leaks with your hand or body.

Be sure equipment safety devices are operating properly before each use.

Medical Alert—Airless Spray Wounds

If any fluid appears to penetrate your skin, get **EMERGENCY MEDICAL CARE AT ONCE. DO NOT TREAT AS A SIMPLE CUT.** Tell the doctor exactly what fluid was injected.

Note to Physician: *Injection in the skin is a traumatic injury. It is important to treat the injury surgically as soon as possible. Do not delay treatment to research toxicity. Toxicity is a concern with some exotic coatings injected directly into the blood stream. Consultation with a plastic surgeon or reconstructive hand surgeon may be advisable.*

Spray Gun Safety Devices

Be sure all spray gun safety devices are operating properly before each use. Do not remove or modify any part of the spray gun; this can cause a malfunction and result in serious bodily injury.

Safety Latch

Whenever you stop spraying, even for a moment, always set the spray gun safety latch in the closed or “safe” position, making the spray gun inoperative. Failure to set the safety latch can result in accidental triggering of the spray gun.

Trigger Guard

Never operate the spray gun with the trigger guard removed. This guard helps prevent the spray gun from triggering accidentally if it is dropped or bumped.

Diffuser (only on spray guns)

The spray gun diffuser breaks up spray and reduces the risk of fluid injection when the tip is not installed. Check the diffuser operation regularly. Follow the **Pressure Relief Procedure**, to the right, then remove the spray tip. Aim the spray gun into a grounded metal pail, holding the spray gun firmly to the pail. Using the lowest possible pressure, trigger the spray gun. If the fluid emitted is not diffused into an irregular stream, replace the diffuser immediately.

Tip Guard (only on spray guns)

ALWAYS have the tip guard in place on the spray gun while spraying. The tip guard alerts you to the fluid injection hazard and helps reduce, **but does not prevent**, the risk of accidentally placing your fingers or any part of your body close to the spray tip.

Spray Tip/Nozzle Safety

Use extreme caution when cleaning or changing spray tips/nozzles. If the spray tip/nozzle clogs while spraying/dispersing, engage the spray gun safety latch immediately. ALWAYS follow the **Pressure Relief Procedure** and then remove the spray tip/nozzle to clean it.

NEVER wipe off build-up around the spray tip/nozzle until pressure is fully relieved and the spray gun safety latch is engaged.

Pressure Relief Procedure

To reduce the risk of serious bodily injury, including fluid injection, splashing in the eyes or on the skin, or injury from moving parts, always follow this procedure whenever you shut off of the pump, when checking or servicing any part of the spray/dispersing system, when installing, cleaning or changing spray tips/nozzles, and whenever you stop spraying/dispersing.

1. Engage the spray gun safety latch.
2. Shut off the air to the pump.
3. Close the bleed-type master air valve (required in your system).
4. Disengage the safety latch.
5. Hold a metal part of the spray gun firmly to the side of a grounded metal pail, and trigger the spray gun to relieve pressure.
6. Engage the spray gun safety latch.
7. Open the drain valve and/or the pump bleeder valve (required in your system), having a container ready to catch the drainage.
8. Leave the drain valve open until you are ready to spray/disperse again.

If you suspect that the spray tip/nozzle or hose is completely clogged, or that pressure has not been fully relieved after following the steps above, VERY SLOWLY loosen the retaining nut or hose end coupling and relieve pressure gradually, then loosen completely. Now clear the tip/nozzle or hose.

EQUIPMENT MISUSE HAZARD

General Safety

Any misuse of the spray equipment or accessories, such as overpressurizing, modifying parts, using incompatible chemicals and fluids, or using worn or damaged parts, can cause them to rupture and result in fluid injection, splashing in the eyes or on the skin, or other serious bodily injury, or fire, explosion or property damage.

NEVER alter or modify any part of this equipment; doing so could cause it to malfunction.

CHECK all spray equipment regularly and repair or replace worn or damaged parts immediately.

Always wear protective eyewear, gloves, clothing and respirator as recommended by the fluid and solvent manufacturer.

HOSE SAFETY

High pressure fluid in the hoses can be very dangerous. If the hose develops a leak, split or rupture due to any kind of wear, damage or misuse, the high pressure spray emitted from it can cause a fluid injection injury or other serious bodily injury or property damage.

ALL FLUID HOSES USED WITH A FLEXING MOTION MUST HAVE SPRING GUARDS ON BOTH ENDS! The spring guards help protect the hose from kinks or bends at or close to the coupling which can result in hose rupture.

TIGHTEN all fluid connections securely before each use. High pressure fluid can dislodge a loose coupling or allow high pressure spray to be emitted from the coupling.

NEVER use a damaged hose. Before each use, check the entire hose for cuts, leaks, abrasion, bulging cover, or damage or movement of the hose couplings. If any of these conditions exist, replace the hose immediately. DO NOT try to recouple high pressure hose or mend it with tape or any other device. A repaired hose cannot safely contain the high pressure fluid.

FIRE OR EXPLOSION HAZARD

Static electricity is created by the high velocity flow of fluid through the pump and hose. If every part of the spray equipment is not properly grounded, sparking may occur, and the system may become hazardous. Sparking may also occur when plugging in or unplugging a power supply cord. Sparks can ignite fumes from solvents and the fluid being sprayed, dust particles and other flammable substances, whether you are spraying indoors or outdoors, and can cause a fire or explosion and serious bodily injury and property damage. Do not plug in or unplug any power supply cords in the spray area when there is any chance of igniting fumes still in the air.

If you experience any static sparking or even a slight shock while using this equipment, **STOP SPRAYING IMMEDIATELY**. Check the entire system for proper grounding. Do not use the system again until the problem has been identified and corrected.

To ground the pump:

To ground the pump, loosen the grounding lug locknut (A) and washer (B). Insert one end of a 1.5 mm² (12 ga) minimum ground wire (D) into the slot in lug (C) and tighten the locknut securely. See Fig 1. Connect the other end of the wire to a true earth ground. See **ACCESSORIES** on page 18 to order a ground wire and clamp.

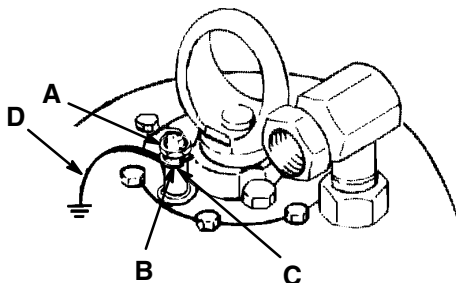

Fig 1

System Pressure

NEVER exceed the recommended working pressure or the maximum air inlet pressure stated on your pump or in the **TECHNICAL DATA** on pages 21–25.

Be sure that all spray/dispensing equipment and accessories are rated to withstand the maximum working pressure of the pump. DO NOT exceed the maximum working pressure of any component or accessory used in the system.

Fluid Compatibility

BE SURE that all fluids and solvents used are chemically compatible with the wetted parts shown in the **TECHNICAL DATA** on pages 21–25. Always read the manufacturer's literature before using fluid or solvent in this pump.

HANDLE AND ROUTE HOSES CAREFULLY. Do not pull on hoses to move equipment. Do not use fluids which are not compatible with the inner tube and cover of the hose. DO NOT expose Graco hoses to temperatures above 82° C (180° F) or below -40° C (-40° F).

Hose Grounding Continuity

Proper hose grounding continuity is essential to maintaining a grounded spray system. Check the electrical resistance of your air and fluid hoses at least once a week. If your hose does not have a tag on it which specifies the maximum electrical resistance, contact the hose supplier or manufacturer for the maximum resistance limits. Use a resistance meter in the appropriate range for your hose to check the resistance. If the resistance exceeds the recommended limits, replace it immediately. An ungrounded or poorly grounded hose can make your system hazardous. Also, read **FIRE OR EXPLOSION HAZARD**, below.

Grounding

To reduce the risk of static sparking, ground the pump, object being sprayed, and all other spray equipment used or located in the spray area. CHECK your local electrical code for detailed grounding instructions for your area and type of equipment. BE SURE to ground all of this spray equipment:

1. *Pump:* use a ground wire and clamp. See Fig 1.
2. *Air hoses:* use only grounded air hoses.
3. *Fluid hoses:* use only grounded fluid hoses.
4. *Air compressor:* follow manufacturer's recommendations.
5. *Spray gun:* grounding is obtained through connection to a properly grounded fluid hose and pump.
6. *Fluid supply container:* according to your local code.
7. *Object being sprayed:* according to your local code.
8. *All solvent pails used when flushing,* according to your local code. Use only metal pails, which are conductive, placed on a grounded surface. Do not place the pail on a nonconductive surface, such as paper or cardboard, which interrupts the grounding continuity.
9. *To maintain grounding continuity when flushing or relieving pressure,* always hold a metal part of the spray gun firmly to the side of a grounded *metal* pail, then trigger the spray gun.

Flushing Safety

Before flushing, be sure the entire system and flushing pails are properly grounded. Refer to **Grounding**, above. Follow the **Pressure Relief Procedure** on page 4, and remove the spray tip/nozzle from the spray gun. Always use the lowest possible fluid pressure, and maintain firm metal-to-metal contact between the spray gun and the pail during flushing to reduce the risk of fluid injection injury, static sparking and splashing.

IMPORTANT

United States Government safety standards have been adopted under the Occupational Safety and Health Act. These standards – particularly the General Standards, Part 1910, and the Construction Standards, Part 1926 – should be consulted.

INSTALLATION

TYPICAL INSTALLATION

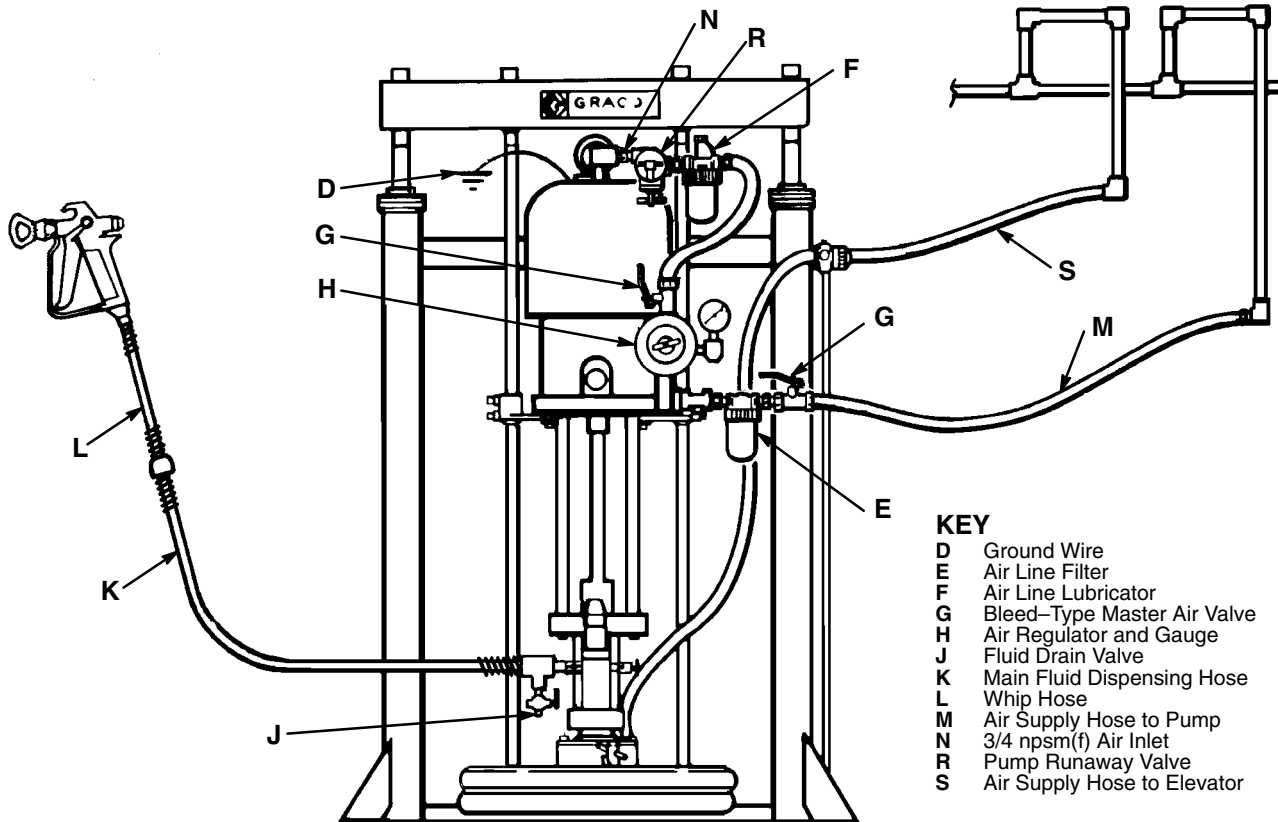

KEY

- D Ground Wire
- E Air Line Filter
- F Air Line Lubricator
- G Bleed-Type Master Air Valve
- H Air Regulator and Gauge
- J Fluid Drain Valve
- K Main Fluid Dispensing Hose
- L Whip Hose
- M Air Supply Hose to Pump
- N 3/4 npsm(f) Air Inlet
- R Pump Runaway Valve
- S Air Supply Hose to Elevator

NOTE: The reference numbers and letters in parentheses in the text refer to the callouts in Figures 1–6 and the Parts Drawing.

The Typical Installation shown above is only a guide to selecting and installing required and optional accessories. For assistance in designing a system to suit your particular needs, contact your Graco representative.

The dimensional drawing on page 26 gives measurements needed for installing the pump on a custom designed mounting.

Accessories

Refer to the **TYPICAL INSTALLATION** drawing, above, and **ACCESSORIES** on page 18–20 for assistance in setting up your system. If you supply your own accessories, be sure they are adequately sized to meet the system's requirements. If your pump is mounted in a ram or an elevator, refer to the manual supplied with it for installation and operation instructions.

Install the accessories in the order shown in the Typical Installation drawing. The pump runaway valve (R) senses when the pump is running too fast and shuts off the air supply to the motor. The air line lubricator (F) provides automatic air motor lubrication. The bleed-type master air valve (G) relieves air trapped between it and the pump when it is closed. Be sure the valve is easily accessible from the pump. The air regulator (H) controls pump speed and outlet pressure. The air line filter (E) removes harmful dirt and moisture from the compressed air supply.

WARNING

Two accessories are required in your system: a bleed-type master air valve (G) and a fluid drain valve (J). These accessories help reduce the risk of serious bodily injury including fluid injection, splashing in the eyes or on the skin, and injury from moving parts if you are adjusting or repairing the pump.

The bleed-type master air valve relieves air trapped between this valve and the pump after the air is shut off. Trapped air can cause the pump to cycle unexpectedly. Locate the valve close to the pump.

The fluid drain valve assists in relieving fluid pressure in the displacement pump, hose and spray gun; triggering the spray gun to relieve pressure may not be sufficient.

Using a suitable adapter, connect a fluid drain valve (J) near the 1 in. npt(f) fluid outlet of the pump. Then connect a grounded fluid supply hose (K). For more flexible spray gun movement, use a shorter 13 mm (1/2 in.) ID hose (L) between the spray gun and the main hose.

GROUNDING

WARNING

Before operating the pump, ground the system as explained under **FIRE OR EXPLOSION HAZARD** and **Grounding** on page 5.

WARNING

To reduce the risk of serious bodily injury, including fluid injection, splashing in the eyes or on the skin, or injury from moving parts, always follow the **Pressure Relief Procedure Warning** on page 8 whenever you shut off the pump, when checking or servicing any part of the spray/dispensing system, when installing, cleaning or changing spray tips or nozzles, and whenever you stop spraying.

Fill the wet-cup (101) one-half full with Graco Throat Seal Liquid (TSL).

Flush the Pump

The pump is tested with lightweight oil, which is left in to protect the pump parts. If the fluid you are using may be contaminated by the oil, flush it out with a compatible solvent before using the pump.

WARNING

For your safety, read the warning section, **FIRE OR EXPLOSION HAZARD** on page 5 before flushing, and follow all the recommendations given there.

Start and Adjust the Pump

Be sure the air regulator (H) is closed. Then open the bleed-type master air valve (G). Hold a metal part of the spray gun firmly to the side of a grounded metal pail and hold the trigger open. Now slowly open the air regulator until the pump starts. See the **TYPICAL INSTALLATION** on page 6.

Cycle the pump slowly until all the air is pushed out and the pump and hoses are fully primed. Release the spray gun trigger and engage the safety latch. The pump will stall against pressure when the trigger is released.

WARNING

Moving parts can pinch or amputate your fingers or other body parts. When the pump is operating, the priming piston (Q) (located at the pump intake) and the air motor piston (located behind the air motor shield) move. Therefore, **NEVER** operate the pump with the air motor shield removed, and keep your fingers and hands away from the priming piston.

Before attempting to clear an obstruction from the priming piston (Q) or service the pump, follow the **Pressure Relief Procedure Warning** on page 8 to prevent the pump from starting accidentally.

If the pump fails to prime properly, open the bleeder valve (139) slightly. Use the bleeder hole (P) as a priming valve until the fluid appears at the hole. See Fig 2. Close the bleeder valve.

WARNING

To reduce the risk of fluid injection, **DO NOT** use your hand or fingers to cover the bleeder hole when priming the pump.

With the pump and lines primed, and with adequate air pressure and volume supplied, the pump will start and stop as the spray gun is opened and closed.

Use the air regulator to control the pump speed and the fluid pressure. Always use the lowest air pressure necessary to get the desired results. Higher pressures cause premature tip/nozzle and pump wear.

WARNING

To reduce the risk of overpressurizing your system, which could result in component rupture and cause serious bodily injury, **NEVER exceed 7 bar (100 psi) MAXIMUM INCOMING AIR PRESSURE to the pump.**

Never allow the pump to run dry of the fluid being pumped. A dry pump will quickly accelerate to a high speed, possibly damaging itself. A pump runaway valve, which shuts off the air supply to the pump if the pump accelerates beyond the pre-set speed, is available. See **ACCESSORIES** on page 18. If your pump accelerates quickly, or is running too fast, stop it immediately and check the fluid supply. If the supply container is empty and air has been pumped into the lines, refill the container and prime the pump and the lines with fluid, or flush and leave it filled with a compatible solvent. Be sure to eliminate all air from the fluid system.

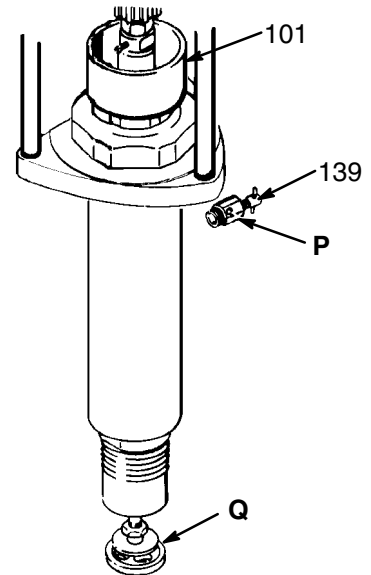

Fig 2

MAINTENANCE

Shutdown and Care of the Pump

For overnight shutdown, follow the **Pressure Relief Procedure Warning**, below. Always stop the pump at the bottom of the stroke to prevent the fluid from drying on the exposed displacement rod and damaging the throat packings.

Flush Regularly and Before Storing the Pump

Always flush the pump before the fluid dries on the displacement rod. Never leave water or water-based fluid in the pump overnight. First, flush with water or a compatible solvent, then with mineral spirits. Relieve the pressure, but leave the mineral spirits in the pump to protect the parts from corrosion.

TROUBLESHOOTING GUIDE

WARNING

Pressure Relief Procedure

To reduce the risk of serious bodily injury, including fluid injection, splashing in the eyes or on the skin, or injury from moving parts, always follow this procedure whenever you shut off the pump, when checking or servicing any part of the spray/dispensing system, when installing, cleaning or changing spray tips/nozzles, and whenever you stop spraying/dispensing.

1. Engage the spray gun safety latch.
2. Shut off the air to the pump.
3. Close the bleed-type master air valve (required in your system).
4. Disengage the safety latch.

5. Hold a metal part of the spray gun firmly to the side of a grounded metal pail, and trigger the spray gun to relieve pressure.
6. Engage the spray gun safety latch.
7. Open the drain valve and/or the pump bleeder valve (required in your system), having a container ready to catch the drainage.
8. Leave the drain valve open until you are ready to use the system again.

If you suspect that the spray tip/nozzle or hose is completely clogged, or that pressure has not been fully relieved after following the steps above, **VERY SLOWLY** loosen the retaining nut or hose end coupling and relieve pressure gradually, then loosen completely. Now clear the tip/nozzle or hose.

NOTE: Check everything in the guide on page 9 before disassembling the pump.

TROUBLESHOOTING GUIDE

PROBLEM	CAUSE	SOLUTION
Pump fails to operate	Restricted line or inadequate air supply	Clear; see TECHNICAL DATA on pages 21–25.
	Insufficient air pressure, closed or clogged air valves, etc.	Open, clear.
	Obstructed fluid hose or spray gun	Clear.*
	Fluid dried on the displacement rod	Clean. See SERVICE .
	Dirty or worn air motor parts	Clean. See air motor manual, supplied.
	Air motor icing	Reduce air line moisture content. **
Pump operates but: –output low on both strokes	Restricted line or inadequate air supply	Clear. See TECHNICAL DATA on pages 21–25.
	Insufficient air pressure, closed or clogged air valves, etc.	Open, clear.
	Obstructed fluid hose or spray gun	Clear.*
	Bleeder valve open	Close.
	Air leaking into supply drum	Check inductor or ram plate seal.
	Fluid too heavy for pump priming	Use bleeder valve (see page 7). Use inductor or ram unit.
	Worn throat packings in displacement pump	Replace gland/packing stack.
	Air motor icing	Reduce air line moisture content.**
–output low on downstroke	Fluid too heavy for pump priming	Use bleeder valve (see page 7). Use inductor or ram unit.
	Held open or worn piston valve or packings	Clear valve; replace gland/packing stack.
	Air motor icing	Reduce air line moisture content.**
–output low on upstroke	Held open or worn piston valve or packings	Clear valve; replace gland/packing stack.
	Air motor icing	Reduce air line moisture content.**
Erratic or accelerated pump speed	Exhausted fluid supply	Refill and prime.
	Fluid too heavy for pump priming	Use bleeder valve (see page 7). Use inductor or ram unit.
	Held open or worn piston valve or packings	Clear valve; replace gland/packing stack.
	Held open or worn priming piston	Clear; service.
	Worn throat packings in displacement pump	Replace gland/packing stack.
	Air motor icing	Reduce air line moisture content.**

* To clear the pump, follow the **Pressure Relief Procedure Warning**, on page 8. Disconnect the fluid line. If the pump starts when the air is turned on, then the fluid hose or spray gun is obstructed.

** Be sure there is a vertical loop in the air line drop hose from the main air supply line. Also use an air and moisture separator to minimize moisture in the air line.

DISPLACEMENT PUMP SERVICE

WARNING

To reduce the risk of serious bodily injury, including injection, splashing in the eyes, or injury from moving parts, always follow the **Pressure Relief Procedure Warning** on page 8 when checking or servicing any part of the spray/dispensing system, when installing, cleaning or changing spray tips/nozzles, and whenever you stop spraying/dispensing.

(See Fig 3 unless otherwise noted.)

1. Flush the pump with compatible solvent if possible. Follow the **Pressure Relief Procedure Warning** on page 8.
2. Disconnect the hoses, remove the pump from its mounting, and clamp it in a vise. Unscrew the coupling nut (9) and the tie rod locknuts (3). Remove the cotter pin (1), loosen the jam nut (5), and unscrew the connecting rod (11) from the displacement rod (108). Pull the motor away from the displacement pump.

NOTE: If you are using a repair kit to service the pump, use all the new parts. See pages 15 and 17 for available kits. Parts included in the kits are marked with a double asterisk, for example, (124**), in the text and drawings.

3. Place the pump housing (109) in a padded jaw vise with the outlet (107) against one jaw.
4. Remove the wet-cup (101), wet-cup packing nut (136), and packing nut (140). Remove the packings from the packing nut.
5. Push the displacement rod (108) down so the priming piston (119) clears the intake cylinder (117).
6. Use two wrenches to oppositely turn and loosen the hex nuts (120) on the piston rod (122).
7. Remove the valve plate (118), valve guide (121), and the priming piston (119).
8. Remove the intake cylinder (117) and o-ring (124).
9. Pull on the piston rod (122) to remove the displacement rod (108) from the pump housing (109).
10. Remove the cotter pin (126) and unthread the piston rod (122) from the piston valve (112).
11. Remove the packing nut (114) from the piston rod (122). Remove the packings and female gland from the intake cylinder's packing housing (REF 117).

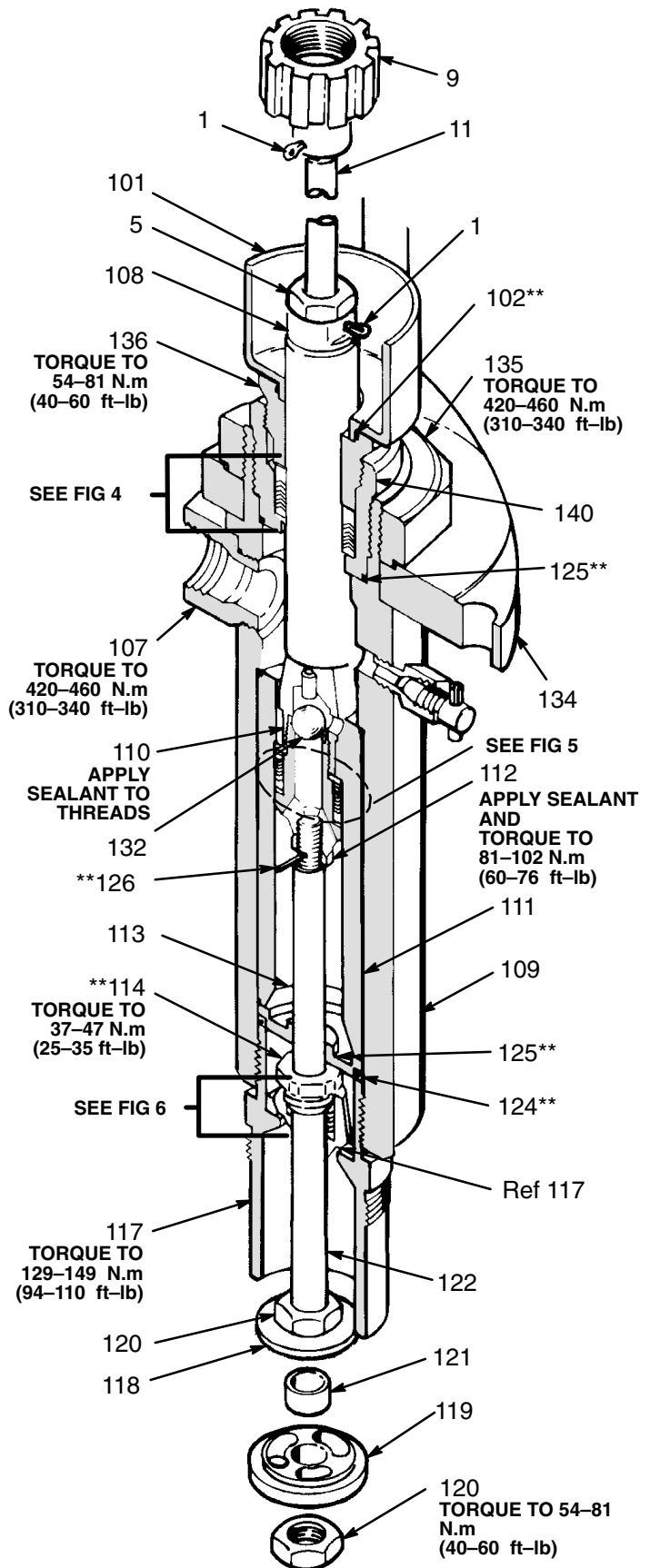

Fig 3

DISPLACEMENT PUMP SERVICE

12. Unscrew the piston valve (112) from the piston valve housing (110), taking care not to drop the piston ball (132).
13. Remove the packings and glands from the piston.
14. Remove the cylinder (111) and o-rings (125). If the cylinder cannot be removed easily, contact the nearest Graco Factory Branch or Service Agency for assistance.
15. Inspect the outer surface of the displacement rod (108) and the inner surface of the pump cylinder (111) for scoring and wear by holding them up to a light or running a finger over the surface. Replace these parts, if necessary. If the rod is worn, the packings will not seal properly and the pump will leak. If the cylinder is worn, the pump will not stall against pressure.
16. Clean all the parts in a compatible solvent, inspect them and replace them as necessary.
17. Place an o-ring (125**) on the packing nut (140). Screw the packing nut into the pump housing (109).

NOTE: Lubricate the parts with a compatible lubricant before assembling.

18. Refer to Fig 4. The gland/packing stack (159**) for the throat is preassembled. **Do not disassemble the stack.** Place the gland/packing stack into the packing nut (140). *Be sure the lips of the v-packings are facing down.*
19. Place an o-ring (102**) in the groove of the wet-cup packing nut (136). Loosely install the wet-cup packing nut (136) and the wet-cup (101) into the pump housing (109).

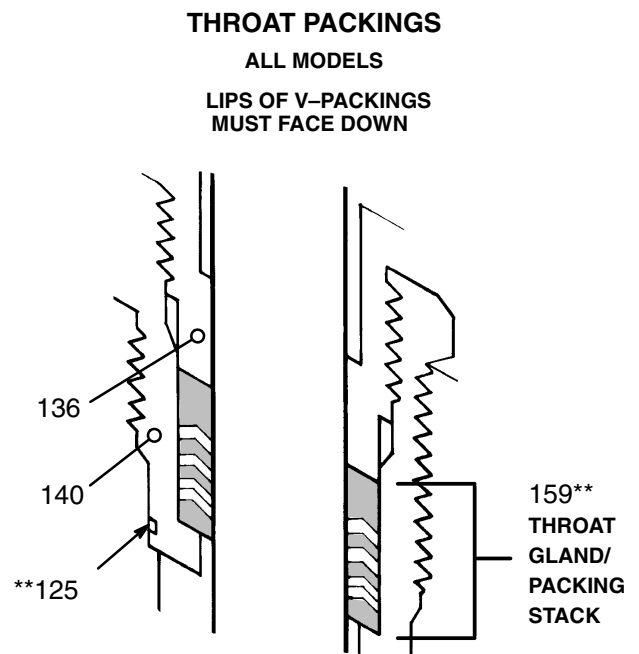

Fig 4

DISPLACEMENT PUMP SERVICE

20. Refer to the illustration in Fig 5 for your displacement pump (217–201 or 220–449). Install the gland/packing stack (160**) on the piston valve (112) as follows, with the lips of the v-packings facing up.

For Model 217–201 Displacement Pump: Slide the gland/packing stack supplied in Repair Kit 222–101 down onto the piston valve (112). **Do not disassemble the packing stack**, and be sure the lips of the packings are facing up. Install the backup washer (131) on top of the gland/packing stack.

For Model 220–449 Displacement Pump: Slide the gland/packing stack supplied in Repair Kit 221–156 down onto the piston valve (112). **Do not disassemble the packing stack**, and be sure the lips of the packings are facing up.

21. Install the piston ball (132) in the piston valve housing (110). Apply medium grade thread sealant to the

threads of the piston valve (112) and housing (110). Screw the piston valve into the piston valve housing, torquing to 81–102 N.m (60–76 ft-lb). Screw the piston rod (122) into the piston valve, aligning the holes. Insert the cotter pin (126**).

22. Place the pump housing (109) in the vise. Install the new o-rings (125**) on the pump cylinder (111). Lubricate the cylinder and slide it into the pump housing as far as possible.

NOTE: In Model 220–449 Displacement Pump, install the pump cylinder so the tapered end faces the bottom of the pump.

23. Slide the rod guide (113) onto the piston rod (122), with the flat side facing down.

24. Install the displacement rod assembly through the bottom of the pump, guiding it carefully through the throat packings.

PISTON PACKINGS

NOTE: LIPS OF V-PACKINGS MUST FACE UP

Model 217–201

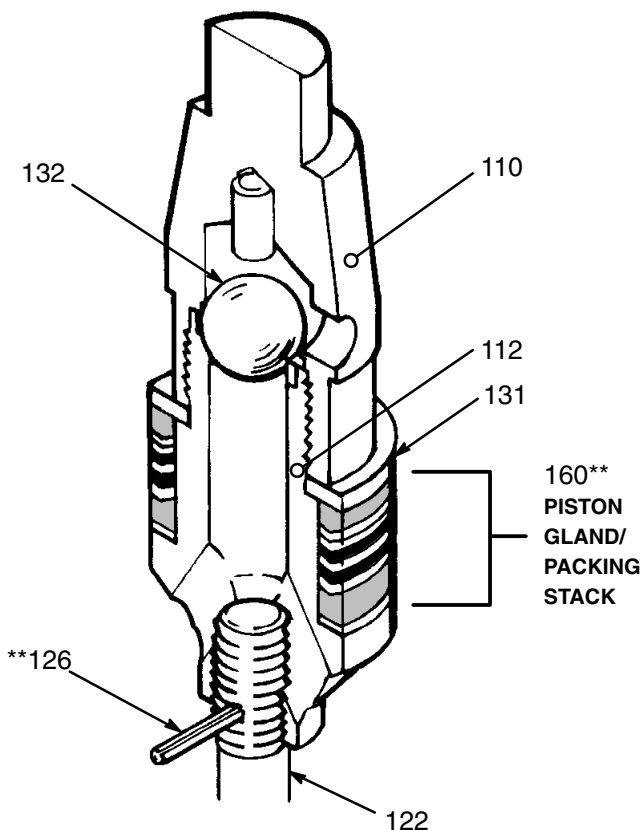

Model 220–449

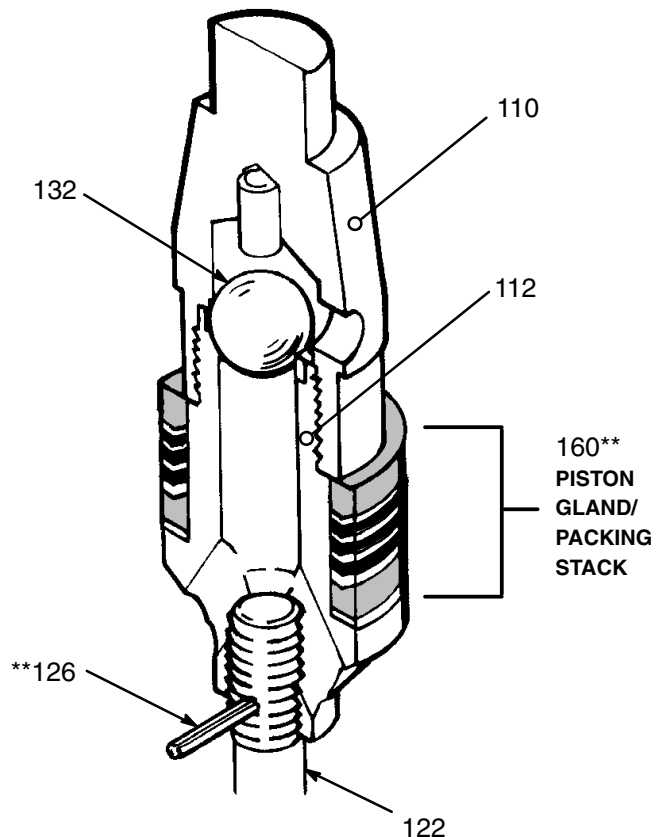

Fig 5

25. Refer to Fig. 6. The gland/packing stack (158**) for the intake valve is preassembled. **Do not disassemble the stack.** Install the gland/packing stack in the intake cylinder's packing housing (REF 117). *Be sure the lips of the v-packings are facing up.* Install the packing nut (114**) and torque to 34–47 N.m (25–35 ft-lb). Slide the assembly, packing nut first, onto the piston rod (122).
26. Place an o-ring (124**) around the intake cylinder (117). Screw the cylinder into the pump housing (109). Torque to 129–149 N.m (94–110 ft-lb).
27. Thread the nut (120) onto the bottom of the piston rod. Install the valve plate (118), valve guide (121), priming piston (119), and the other nut (120).
28. Holding both nuts (120) with a wrench, torque the bottom nut to 54–81 N.m (40–60 ft-lb).
29. Tighten the packing nut (140). Torque the wet-cup nut (136) to 54–81 N.m (40–60 ft-lb).
30. Reconnect the displacement pump (14) to the air motor (15). Refill the wet-cup (101) with TSL. Reconnect the ground wire to the air motor if it was disconnected during service.

INTAKE PACKINGS

All Models

NOTE: LIPS OF V-PACKINGS
MUST FACE UP

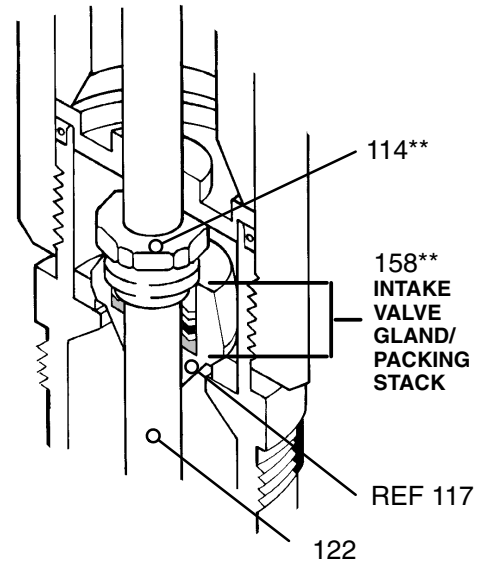
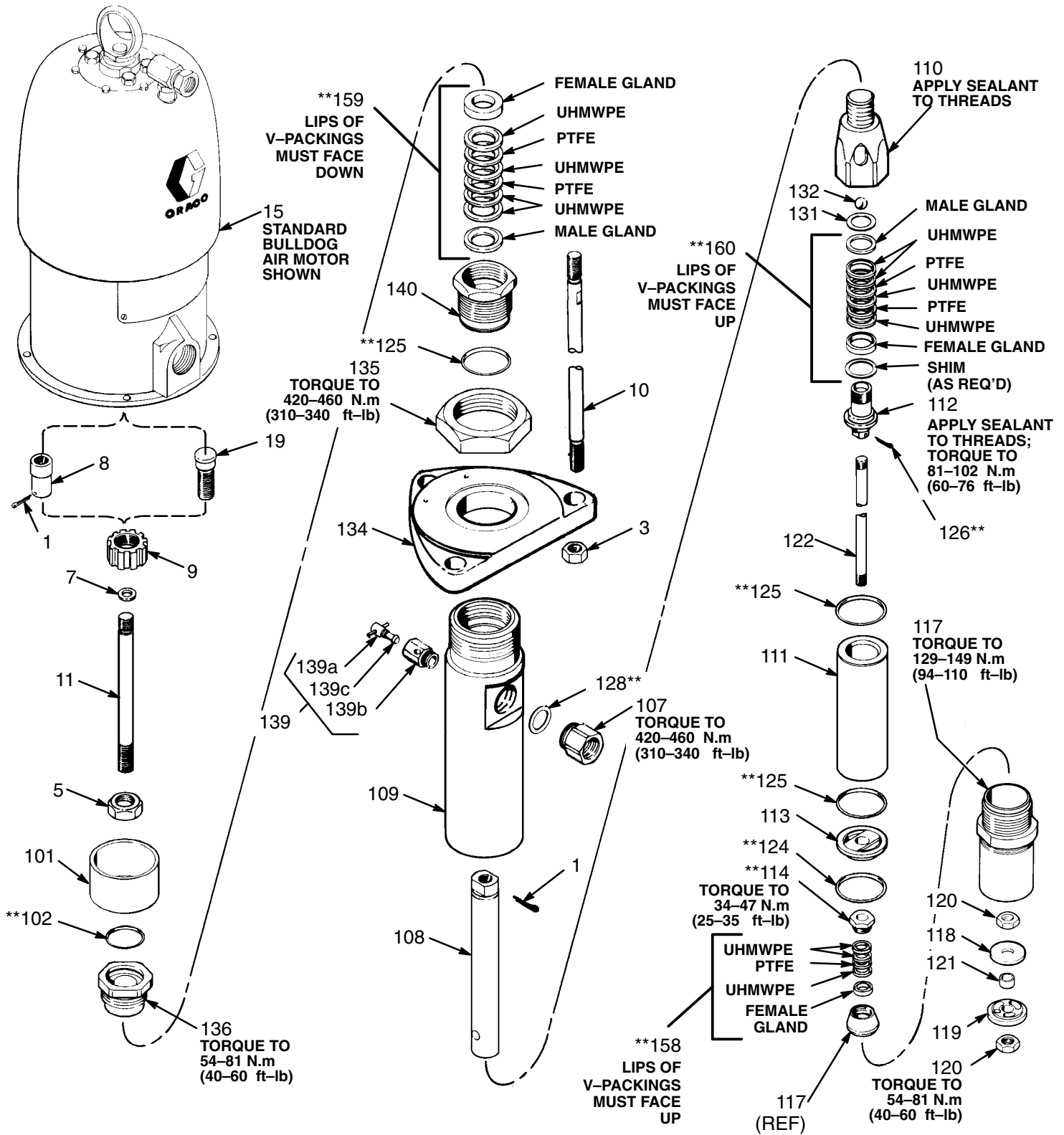

Fig 6

PARTS DRAWING – 15:1 SENATOR, 25:1 BULLDOG & 55:1 KING PUMPS



PARTS LIST – 15:1 SENATOR, 25:1 BULLDOG & 55:1 KING PUMPS

BULLDOG 19 liter (5 gal) drum size

25:1 Ratio Bulldog, Model 217–564, Series D
With Standard Air Motor
Includes items 1–20, below.

REF NO.	PART NO.	DESCRIPTION	QTY
1	100–103	PIN, cotter	1
3	101–712	NUT, lock; 5/8–11; with nylon insert	3
5	101–936	NUT, jam hex; 3/4–10 thread	1
9	161–544	NUT, shoulder; 1–1/4–12 thread	1
10	167–911	ROD, tie; 178 mm (7") between shoulders; 5/8–11 thread	3
14	217–201	DISPLACEMENT PUMP; <i>SEE PARTS LIST TO RIGHT</i>	1
15	208–356	BULLDOG STANDARD AIR MOTOR; <i>see 307–049 for parts</i>	1
19	166–548	ROD, connecting; 30 mm (1.16") between holes	1
20	176–529+	LABEL, WARNING (not shown)	1

BULLDOG 200 liter (55 gal) drum size

25:1 Ratio Bulldog, Model 217–565, Series A
With Standard Air Motor
Includes items 1–15, below.

25:1 Ratio Bulldog, Model 222–228, Series A
With Quiet Air Motor
Includes items 1–15, below.

SENATOR 200 liter (55 gal) drum size

15:1 Ratio Senator, Model 222–489, Series A
With Standard Air Motor
Includes items 1–15, below.

KING 200 liter (55 gal) drum size

55:1 Ratio King, Model 217–566, Series A
With Standard Air Motor
Includes items 1–15, below

55:1 Ratio King, Model 222–229, Series A
With Quiet Air Motor
Includes items 1–15, below

REF NO.	PART NO.	DESCRIPTION	QTY
1	100–103	PIN, cotter	2
3	101–712	NUT, lock; 5/8–11 with nylon insert	3
5	101–936	NUT, jam hex; 3/4–10 thread	1
7	158–674	O–RING; buna–N	1
8	168–211	NUT, connecting rod; 3/4–10 thread	1
9	168–210	NUT, shoulder; 1–1/4–12 thread	1
10	168–254	ROD, tie; 344 mm (13.56") between shoulders; 5/8–11 thread	3
11	168–253	ROD, connecting; 171 mm (6.75") between holes	1
14	217–201	DISPLACEMENT PUMP; <i>SEE PARTS LIST TO RIGHT</i>	1
15	208–356	BULLDOG STANDARD AIR MOTOR; Used on Model 217–565 <i>see 307–049 for parts</i>	1
	215–255	BULLDOG QUIET AIR MOTOR; Used on Model 222–228 <i>see 307–304 for parts</i>	1
	207–647	KING STANDARD AIR MOTOR; Used on Model 217–566 <i>see 306–968 for parts</i>	1
	220–016	KING QUIET AIR MOTOR; Used on Model 222–229 <i>see 307–741 for parts</i>	1
	217–540	SENATOR STANDARD AIR MOTOR Used on Model 222–489 <i>see 307–592 for parts</i>	1

DISPLACEMENT PUMP 217–201, Series E

With UHMWPE & PTFE packings
Includes items 101 to 160

REF NO.	PART NO.	DESCRIPTION	QTY
101	178–098	WET–CUP	1
102	106–258**	O–RING, Viton®	1
107	178–080	ADAPTER, outlet; M39(m)x1" npt(f)	1
108	178–151	ROD, displacement	1
109	178–126	HOUSING, pump	1
110	217–549	HOUSING, valve, piston	1
111	178–154	CYLINDER, pump	1
112	222–100	VALVE, piston	1
113	178–086	GUIDE, rod	1
114	183–755**	NUT, packing	1
117	222–637	CYLINDER, valve, intake	1
118	178–162	PLATE, valve, check	1
119	178–090	PISTON, priming	1
120	106–257	NUT, machine, hex; M16	2
121	178–109	GUIDE, valve	1
122	178–089	ROD, piston	1
124	106–260**	O–RING; PTFE	1
125	106–259**	O–RING; PTFE	3
126	100–103**	PIN, cotter	1
128	107–083**	O–RING; Viton®	1
131	178–163	WASHER, back–up	1
132	106–269*	BALL, piston	1
134	178–081	PLATE, tie	1
135	178–079	NUT, cylinder; M80	1
136	178–149	NUT, packing, wet–cup	1
139	206–256	BLEEDER VALVE ASSEMBLY; includes items 139a–139c	1
139a	102–039	.PIN, spring	1
139b	165–702	.BODY, bleeder valve	1
139c	165–703	.PLUG, bleeder valve	1
140	180–394	NUT, packing	1
141	172–477+	TAG, instruction (not shown)	1
158	223–361**	GLAND/PACKING STACK, intake valve	1
159	223–362**	GLAND/PACKING STACK, throat	1
160	223–363**	GLAND/PACKING STACK, piston	1

307 numbers in descriptions refer to separate instruction manuals.

* Recommended "tool box" spare parts. Keep on hand to reduce down time.

** Supplied in repair kit 222–101.

+ Extra warning labels and tags are available at no charge.

Refer to "How to Order Parts" on page 27.

Standard PACKING REPAIR KIT 222–101

PTFE and UHMWPE

Must be purchased separately.

See doubled–starred (**) parts in list above.

Optional PACKING REPAIR STACKS

Leather and UHMWPE

Must be purchased separately.

223–490 Throat Gland/Packing Stack

223–491 Piston Gland/Packing Stack

223–494 Intake Valve Gland/Packing Stack

PISTON CONVERSION KIT 222–400

Must be purchased separately.

To convert a Series A 217–201 Displacement Pump to a current style. Includes 222–101 packing repair kit and 222–100 piston.

PARTS DRAWING – 25:1 SENATOR AND 40:1 BULLDOG PUMPS

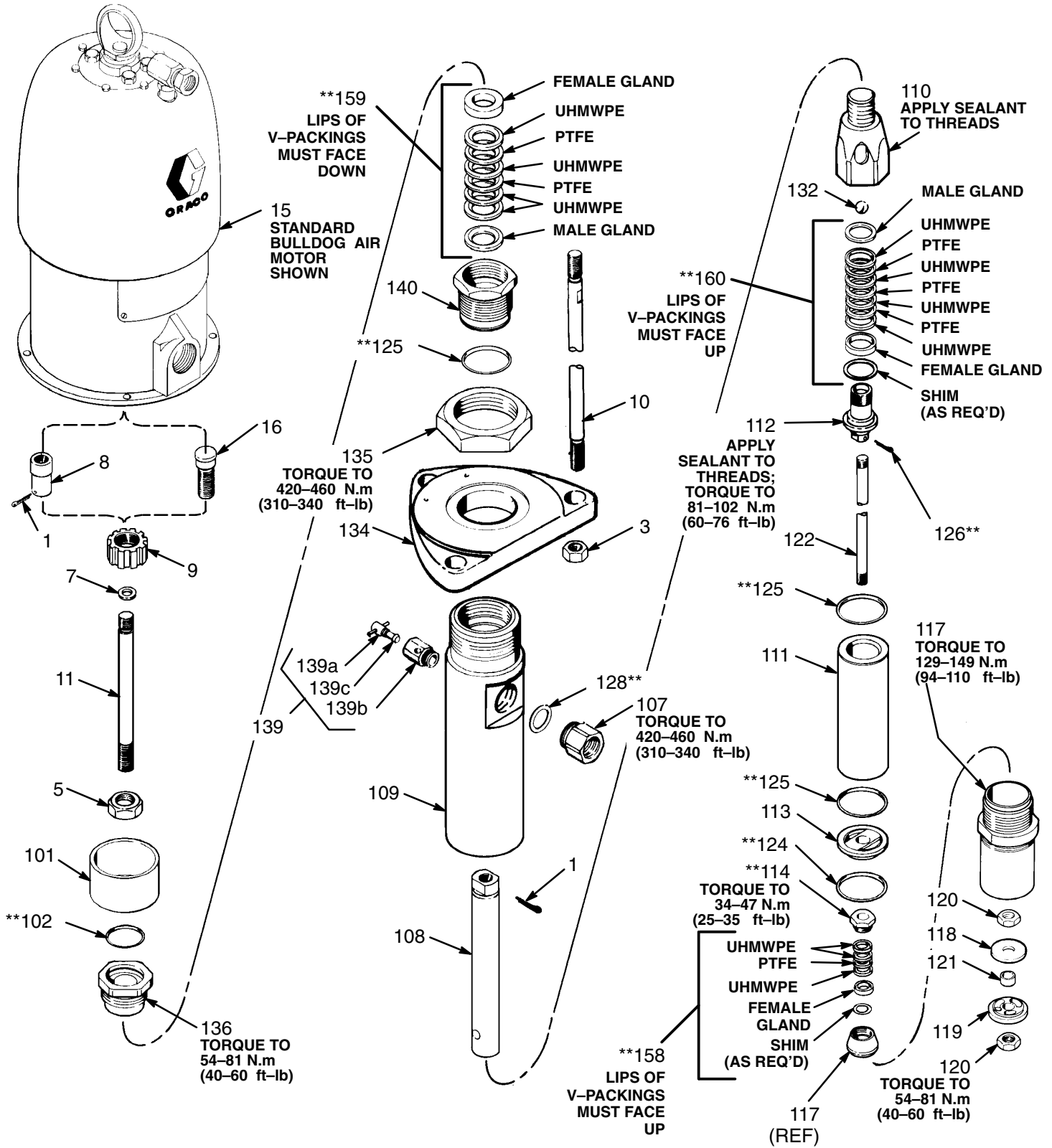

PARTS LIST – 25:1 SENATOR AND 40:1 BULLDOG PUMPS

USE GENUINE GRACO PARTS AND ACCESSORIES

25:1 Ratio Senator, Model 222–519, Series A
200 liter (55 gal) drum size
Includes items 1–15, below

REF NO.	PART NO.	DESCRIPTION	QTY
1	100–103	PIN, cotter	2
3	101–712	NUT, lock; 5/8–11 with nylon insert	3
5	101–936	NUT, jam hex; 3/4–10 thread	1
7	158–674	O–RING; buna–N	1
8	168–211	NUT, connecting rod; 3/4–10 thread	1
9	168–210	NUT, shoulder; 1–1/4”–12 thread	1
10	168–254	ROD, tie; 344 mm (13.56”) between shoulders; 5/8–11 thread	3
11	168–253	ROD, connecting; 171 mm (6.75”) between holes	1
14	220–449	DISPLACEMENT PUMP; <i>SEE PARTS LIST TO RIGHT</i>	1
15	217–540	AIR MOTOR; see 307–592 for parts	1

40:1 Ratio Bulldog, Model 220–448, Series A
200 liter (55 gal) drum size
Includes items 1–15, below

REF NO.	PART NO.	DESCRIPTION	QTY
1	100–103	PIN, cotter	2
3	101–712	NUT, lock; 5/8–11 with nylon insert	3
5	101–936	NUT, jam hex; 3/4–10 thread	1
7	158–674	O–RING; buna–N	1
8	168–211	NUT, connecting rod; 3/4–10 thread	1
9	168–210	NUT, shoulder; 1–1/4”–12 thread	1
10	168–254	ROD, tie; 344 mm (13.56”) between shoulders; 5/8–11 thread	3
11	168–253	ROD, connecting; 171 mm (6.75”) between holes	1
14	220–449	DISPLACEMENT PUMP; <i>SEE PARTS LIST TO RIGHT</i>	1
15	208–356	AIR MOTOR; see 307–049 for parts	1

40:1 Ratio Bulldog, Model 220–447, Series A
19 liter (5 gal) ram size
Includes items 1–16, below

REF NO.	PART NO.	DESCRIPTION	QTY
1	100–103	PIN, cotter	1
3	101–712	NUT, lock; 5/8–11; with nylon insert	3
5	101–936	NUT, jam hex; 3/4–10 thread	1
9	161–544	NUT, shoulder; 1–1/4”–12 thread	1
10	167–911	ROD, tie; 178 mm (7”) between shoulders; 5/8–11 thread	3
14	220–449	DISPLACEMENT PUMP; <i>SEE PARTS LIST TO RIGHT</i>	1
15	208–356	AIR MOTOR; see 307–049 for parts	1
16	166–548	ROD, connecting; 30 mm (1.16”) between holes	1

DISPLACEMENT PUMP 220–449, Series D
with UHMWPE and PTFE packings
Includes items 101 to 160

REF NO.	PART NO.	DESCRIPTION	QTY
101	178–098	WET–CUP	1
102	106–258**	O–RING, Viton®	1
107	178–080	ADAPTER, outlet; M39(m)x1” npt(f)	1
108	178–088	ROD, displacement	1
109	178–126	HOUSING, pump	1
110	217–550	HOUSING, valve, piston	1
111	178–083	CYLINDER, pump	1
112	222–032	VALVE, piston	1
113	178–086	GUIDE, rod	1
114	183–755**	NUT, packing	1
117	222–636	CYLINDER, valve, intake	1
118	178–111	PLATE, valve, check	1
119	178–091	PISTON, priming	1
120	106–257	NUT, machine, hex; M16	2
121	178–109	GUIDE, valve	1
122	178–089	ROD, piston	1
124	106–260**	O–RING; PTFE	1
125	106–259**	O–RING; PTFE	3
126	100–103**	PIN, cotter	1
128	107–083**	O–RING; Viton®	1
132	101–190*	BALL, piston	1
134	178–081	PLATE, tie	1
135	178–079	NUT, cylinder; M80	1
136	178–097	NUT, packing, wet–cup	1
139	206–256	BLEEDER VALVE ASSEMBLY; includes items 139a–139c	1
139a	102–039	.PIN, spring	1
139b	165–702	.BODY, bleeder valve	1
139c	165–703	.PLUG, bleeder valve	1
140	180–394	NUT, packing	1
141	172–477+	TAG, instruction (not shown)	1
158	223–361**	GLAND/PACKING STACK, intake valve	1
159	223–359**	GLAND/PACKING STACK, throat	1
160	223–360**	GLAND/PACKING STACK, piston	1

307 numbers in descriptions refer to separate instruction manuals.

* Recommended “tool box” spare parts. Keep on hand to reduce down time.

** Supplied in repair kit 221–156.

+ Extra warning labels and tags are available at no charge.

Refer to “How to Order Parts” on page 27.

Standard PACKING REPAIR KIT 221–156

PTFE and UHMWPE

Must be purchased separately.

See double–starred (**) parts in list above.

Optional PACKING REPAIR STACKS

Leather and UHMWPE

Must be purchased separately.

223–492 Throat Gland/Packing Stack

223–493 Piston Gland/Packing Stack

223–494 Intake Valve Gland/Packing Stack

PISTON CONVERSION KIT 222–399

Must be purchased separately.

To convert a Series A 220–449 Displacement Pump to a current style. Includes 221–156 packing repair kit and 222–032 piston.

ACCESSORIES

USE GENUINE GRACO PARTS AND ACCESSORIES

Must be purchased separately.

GROUNDING CLAMP 103-538
GROUND WIRE 208-950
 7.6 m (25 ft) long,
 1.5 mm² (12 gauge)

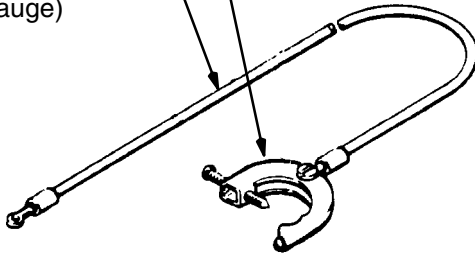

BLEED-TYPE MASTER AIR VALVE 107-141
 21 bar (300 psi) MAXIMUM WORKING PRESSURE
 3/4 npt(mx) inlet and outlet

Relieves air trapped in the air line between the pump air inlet and this valve when closed.

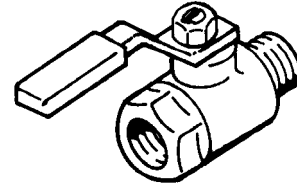

AIR PRESSURE REGULATOR KIT
 14 bar (200 psi) MAXIMUM WORKING PRESSURE
 Includes bleed-type master air valve

205-712 For Bulldog pumps
207-651 For King pumps

3/4 npt BLEED-TYPE
 MASTER AIR VALVE

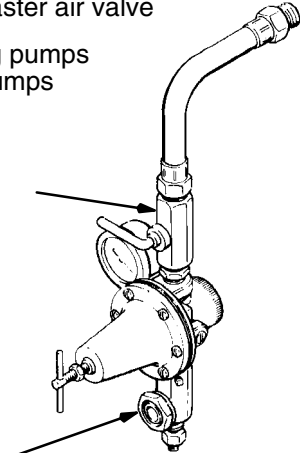

3/4 npsm(f) SWIVEL
 AIR INLET UNION

PUMP RUNAWAY VALVE 215-362
 12 bar (180 psi) MAXIMUM WORKING PRESSURE
 Shuts off air supply to the pump if the pump accelerates beyond the pre-adjusted setting due to an empty supply container, interrupted fluid supply to the pump, or excessive cavitation. 3/4 npt(f).

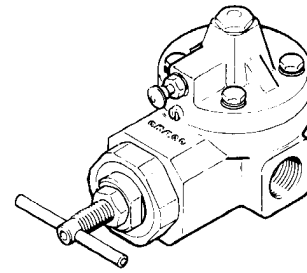

FLUID DRAIN VALVE 210-658
 350 bar (5000 psi) MAXIMUM WORKING PRESSURE
 3/8 npt (mbe); Viton seals

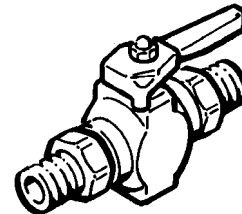

AIR LINE FILTER 106-150
 17.5 bar (250 psi) MAXIMUM WORKING PRESSURE
 3/4 npt inlet and outlet

AIR LINE LUBRICATOR 214-849
 17.5 bar (250 psi) MAXIMUM WORKING PRESSURE
 3/4 npt inlet and outlet

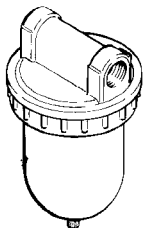

FILTER 106-150

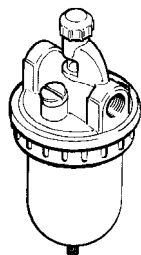

LUBRICATOR 214-849

GRACO THROAT SEAL LIQUID
 Non-evaporating liquid for wet cup

206-995 0.95 liter (1 quart)
206-996 3.8 liter (1 gallon)

AIR MOTOR SILENCER
208-804 Encloses motor to reduce the noise of the King™ pump. Install on a barrel ram.
214-766 Encloses motor to reduce the noise of the Bulldog® pump.

ACCESSORIES CONTINUED ON THE NEXT PAGE

USE GENUINE GRACO PARTS AND ACCESSORIES

Must be purchased separately.

EXTRUSION FLO GUN 207-945

420 bar (6000 psi) MAXIMUM WORKING PRESSURE
Pistol-type trigger. 1/2 npt(f) inlet.

HYDRA-MASTIC™ POLE GUN 207-127

210 bar (3000 psi) MAXIMUM WORKING PRESSURE
Has 30 in. extension, 30° tip angle. Order tip separately.

HYDRA-MASTIC™ GUN 206-718

210 bar (3000 psi) MAXIMUM WORKING PRESSURE
For extra viscous materials. 1/2 npsm(m) inlet.

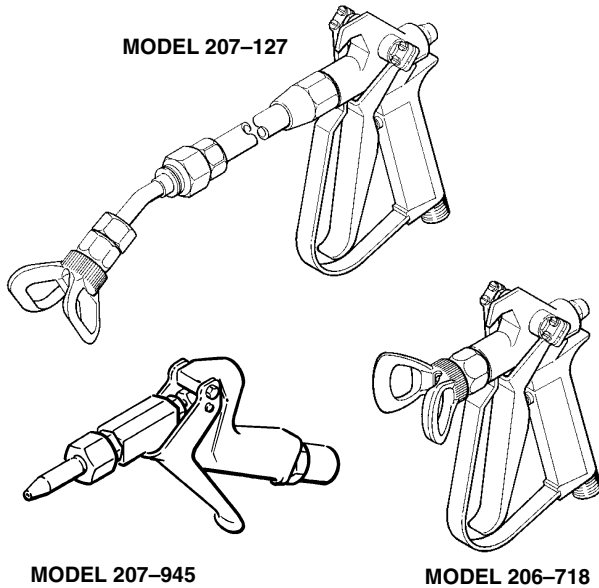

200 LITER (55 gallon) RAM 207-279

For extruding highly viscous fluids from open 200 liter (55 gallon) drums.

TWO-POST 19 LITER (5 gallon) RAM 520-075

For extruding highly viscous fluids from open 19 liter (5 gallon) drums.

SINGLE POST 19 LITER (5 gallon) RAM 206-450

For extruding highly viscous fluids from 19 liter (5 gallon) pails. If an inductor plate is needed, order inductor plate part number 206-747.

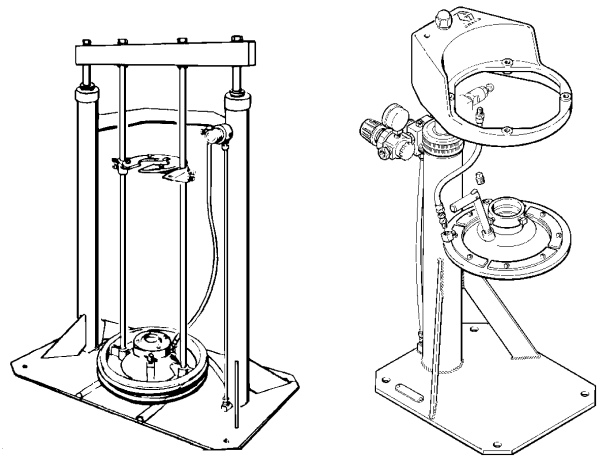

FLOOR STAND KIT 222-689

Provides secure floor mounting for pump when used with bulk fluid containers. 3" npt fluid inlet. Includes instructions.

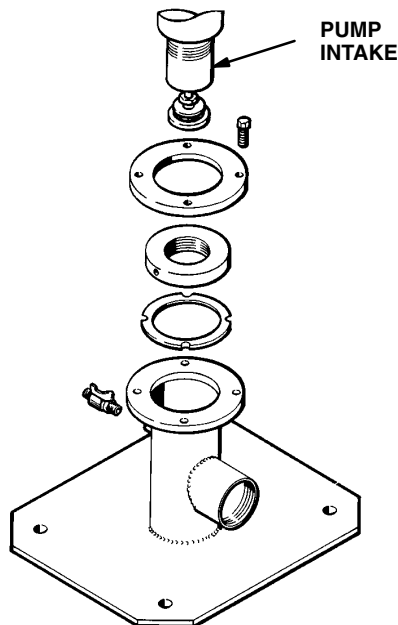

INDUCTOR PLATE 206-747

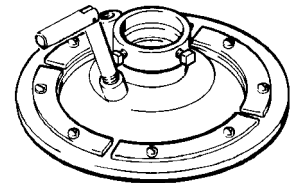

ACCESSORIES CONTINUED ON THE NEXT PAGE

ACCESSORIES

USE GENUINE GRACO PARTS AND ACCESSORIES

Must be purchased separately.

GROUNDING BUNA-N AIR SUPPLY HOSE

175 psi (12 bar) MAXIMUM WORKING PRESSURE

Part No.	ID	Length	Thd. Size
208-610	3/4" (19 mm)	6 ft (1.8 m)	3/4 npt(m)
205-548	3/4" (19 mm)	15 ft (4.6 m)	3/4 npt(m)
208-611	3/4" (19 mm)	25 ft (7.6 m)	3/4 npt(m)
208-612	3/4" (19 mm)	50 ft (15.2 m)	3/4 npt(m)

GROUNDING BUNA-N FLUID HOSE

3500 psi (240 bar) MAXIMUM WORKING PRESSURE

Part No.	ID	Length	Thd. Size
214-962	1/2" (12.7 mm)	15 ft (4.6 m)	1/2 npt(m)
214-963	1/2" (12.7 mm)	25 ft (7.6 m)	1/2 npt(m)
214-964	1/2" (12.7 mm)	50 ft (15.2 m)	1/2 npt(m)

GROUNDING NYLON FLUID HOSE

3000 psi (210 bar) MAXIMUM WORKING PRESSURE

Part No.	ID	Length	Thd. Size
214-700	3/16" (4.8 mm)	2 ft (610 mm) (fbc) swivel	1/4 npsm
214-701	3/16" (4.8 mm) x 1/4 npsm(f) swivel	3 ft (914 mm)	1/4 npt(m)
210-540	1/4" (6.4 mm)	25 ft (7.6 m)	1/4 npsm (fbc) swivel
210-541	1/4" (6.4 mm)	50 ft (15.2 m) (fbc) swivel	1/4 npsm
214-703	3/8" (9.5 mm)	25 ft (7.6 m)	3/8 npt (mbe)
214-705	3/8" (9.5 mm)	50 ft (15.2 m)	3/8 npt (mbe)
214-920	3/8" (9.5 mm)	100 ft (30.4 m)	3/8 npt (mbe)

GROUNDING BUNA-N FLUID HOSE

5000 psi (345 bar) MAXIMUM WORKING PRESSURE

Part No.	ID	Length	Thd. Size
215-445	1/2" (12.7 mm)	5 ft (1.5 m)	1/2 npt (mbe)
215-441	1/2" (12.7 mm)	10 ft (3.1 m)	1/2 npt (mbe)
215-443	1/2" (12.7 mm)	25 ft (7.6 m)	1/2 npt (mbe)
215-444	1/2" (12.7 mm)	50 ft (15.2 m)	1/2 npt (mbe)

GROUNDING NEOPRENE FLUID HOSE

5000 psi (345 bar) MAXIMUM WORKING PRESSURE

Part No.	ID	Length	Thd. Size
215-241	3/4" (19.1 mm)	6 ft (1.8 m)	3/4 npt (mbe)
215-238	3/4" (19.1 mm)	10 ft (3.1 m)	3/4 npt (mbe)
215-239	3/4" (19.1 mm)	15 ft (4.6 m)	3/4 npt (mbe)
215-240	3/4" (19.1 mm)	25 ft (7.6 m)	3/4 npt (mbe)

TECHNICAL DATA – 15:1 RATIO SENATOR PUMP

Maximum working pressure	107 bar (1560 psi)
Air operating range	0.7–7 bar (10–100 psi)
Pump cycles per 3.8 liters (per 1 gallon)	20
Maximum recommended pump speed for intermittent operation	60 cycles per minute
Air inlet size	3/4 npsm(f)
Fluid outlet size	1" npt(f)
Wetted parts	Zinc-plated Carbon Steel, Nitralloy Steel, Ultra-high Molecular Weight Polyethylene, PTFE, Viton®
Stroke length	120 mm (4.75")

Viton® is a registered trademark of the Company

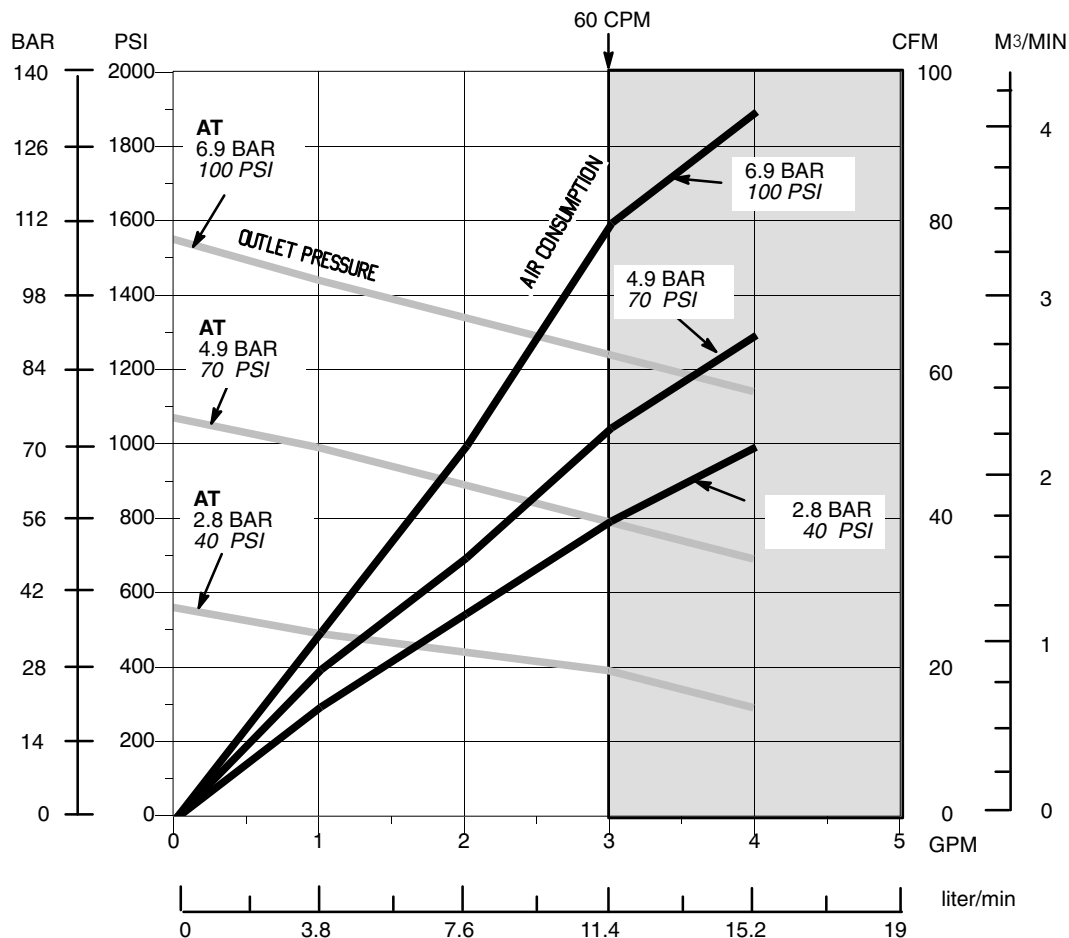

PUMP PERFORMANCE CHART

To find Outlet Pressure (bar/psi) at a specific delivery (liter/min–GPM) and operating air pressure (bar/psi):

1. Locate desired delivery along bottom of chart.
2. Read vertical line up to intersection with selected fluid outlet pressure curve. Curve slopes from left to right. Follow left to scale and read outlet pressure.

To find Pump Air Consumption (m3/min–CFM) specific delivery (liter/min–GPM) and operating air pressure (bar/psi):

1. Locate desired delivery along bottom of chart.
2. Read vertical line up to intersection with selected air consumption curve. Curve slopes from right to left. Follow right to scale and read air consumption. Follow left to scale and read outlet pressure.

■ TECHNICAL DATA – 25:1 RATIO SENATOR PUMP ■

- Maximum working pressure 175 bar (2500 psi)
- Air operating range 0.7–7 bar (10–100 psi)
- Pump cycles per 3.8 liters (per 1 gallon) 20
- Maximum recommended pump speed
for intermittent operation 60 cycles per minute
- Air inlet size 3/4 npsm(f)
- Fluid outlet size 1" npt(f)
- Wetted parts Zinc-plated Carbon Steel, Nitralloy Steel,
Ultra-high Molecular Weight Polyethylene, PTFE, Viton®
- Stroke length 120 mm (4.75")

Viton® is a registered trademark of the Company

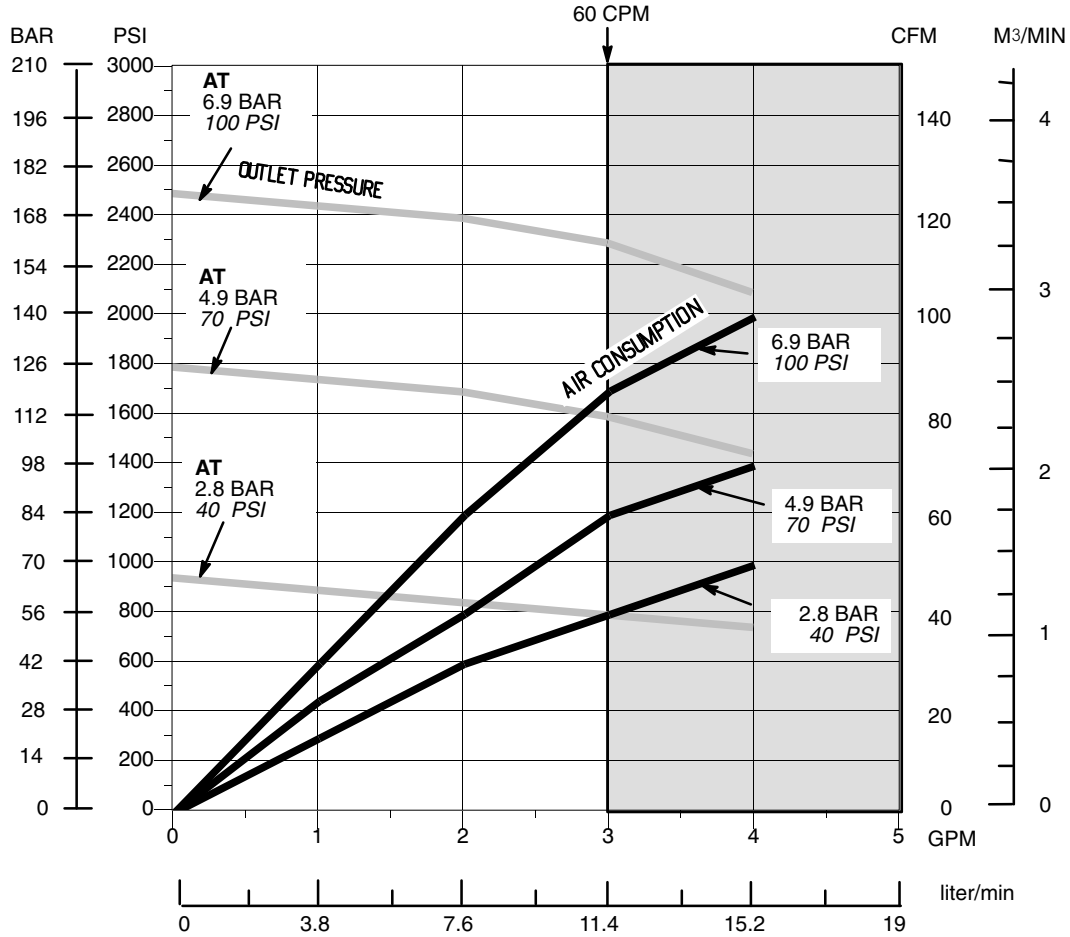

PUMP PERFORMANCE CHART

To find Outlet Pressure (bar/psi) at a specific delivery (liter/min–GPM) and operating air pressure (bar/psi):

1. Locate desired delivery along bottom of chart.
2. Read vertical line up to intersection with selected fluid outlet pressure curve. Curve slopes from left to right. Follow left to scale and read outlet pressure.

To find Pump Air Consumption (m³/min–CFM) specific delivery (liter/min–GPM) and operating air pressure (bar/psi):

1. Locate desired delivery along bottom of chart.
2. Read vertical line up to intersection with selected air consumption curve. Curve slopes from right to left. Follow right to scale and read air consumption. Follow left to scale and read outlet pressure.

TECHNICAL DATA – 25:1 RATIO BULLDOG PUMP

Maximum working pressure	175 bar (2500 psi)
Air operating range	0.7–7 bar (10–100 psi)
Pump cycles per 3.8 liters (per 1 gallon)	20
Maximum recommended pump speed for intermittent operation	60 cycles per minute
Air inlet size	3/4 npsm(f)
Fluid outlet size	1" npt(f)
Wetted parts	Zinc-plated Carbon Steel, Nitralloy Steel, Ultra-high Molecular Weight Polyethylene, PTFE, Viton®
Stroke length	120 mm (4.75")

Viton® is a registered trademark of the _____ Company

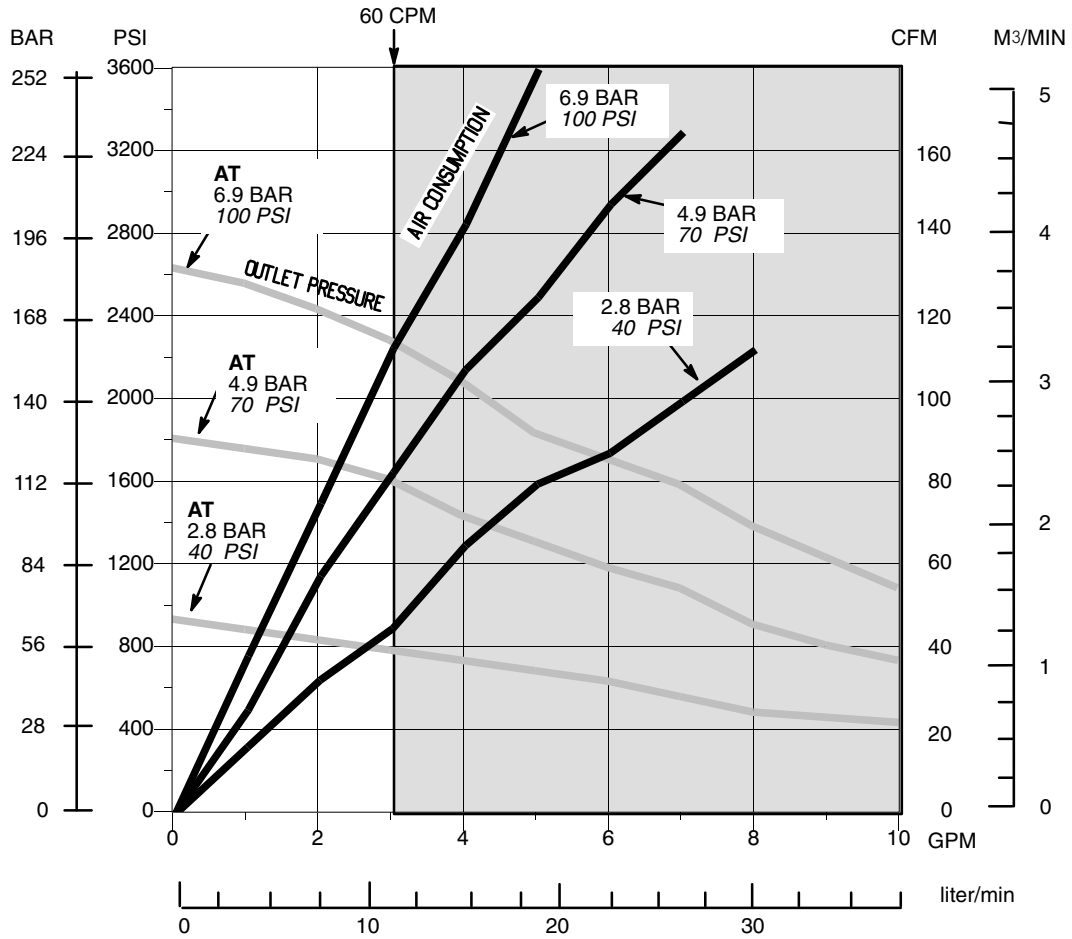

PUMP PERFORMANCE CHART

To find Outlet Pressure (bar/psi) at a specific delivery (liter/min–GPM) and operating air pressure (bar/psi):

1. Locate desired delivery along bottom of chart.
2. Read vertical line up to intersection with selected fluid outlet pressure curve. Curve slopes from left to right. Follow left to scale and read outlet pressure.

To find Pump Air Consumption (m3/min–CFM) specific delivery (liter/min–GPM) and operating air pressure (bar/psi):

1. Locate desired delivery along bottom of chart.
2. Read vertical line up to intersection with selected air consumption curve. Curve slopes from right to left. Follow right to scale and read air consumption. Follow left to scale and read outlet pressure.

TECHNICAL DATA – 40:1 RATIO BULLDOG PUMP

Maximum working pressure 280 bar (4000 psi)
 Air operating range 0.7–7 bar (10–100 psi)
 Pump cycles per 3.8 liters (per 1 gallon) 28
 Maximum recommended pump speed
 for intermittent operation 60 cycles per minute
 Air inlet size 3/4 npsm(f)
 Fluid outlet size 1" npt(f)
 Wetted parts Zinc-plated Carbon Steel, Nitralloy Steel,
 Ultra-high Molecular Weight Polyethylene, PTFE, Viton®
 Stroke length 120 mm (4.75")

Viton®

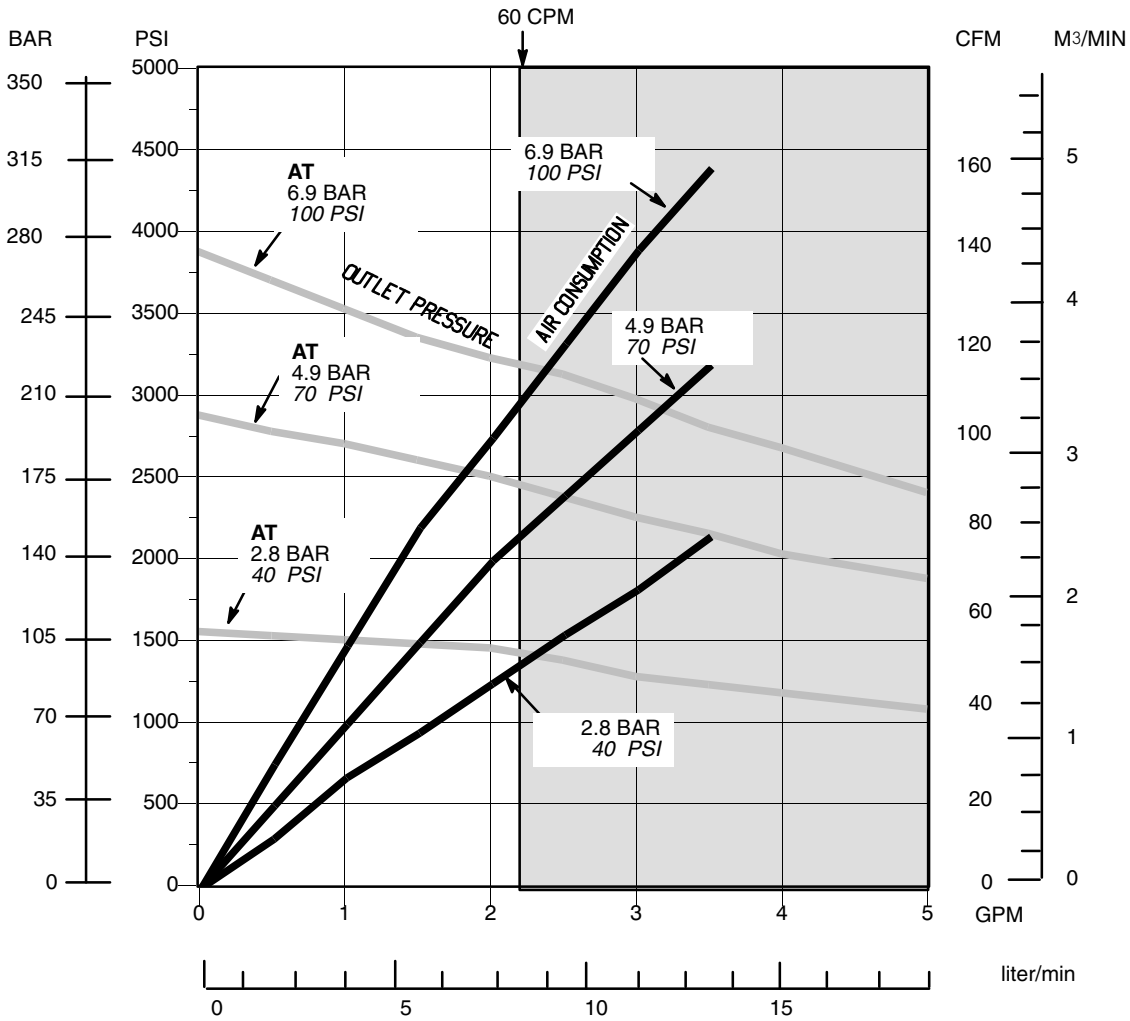

PUMP PERFORMANCE CHART

To find Outlet Pressure (bar/psi) at a specific delivery (liter/min–GPM) and operating air pressure (bar/psi):

1. Locate desired delivery along bottom of chart.
2. Read vertical line up to intersection with selected fluid outlet pressure curve. Curve slopes from left to right. Follow left to scale and read outlet pressure.

To find Pump Air Consumption (m3/min–CFM) specific delivery (liter/min–GPM) and operating air pressure (bar/psi):

1. Locate desired delivery along bottom of chart.
2. Read vertical line up to intersection with selected air consumption curve. Curve slopes from right to left. Follow right to scale and read air consumption. Follow left to scale and read outlet pressure.

DIMENSIONS

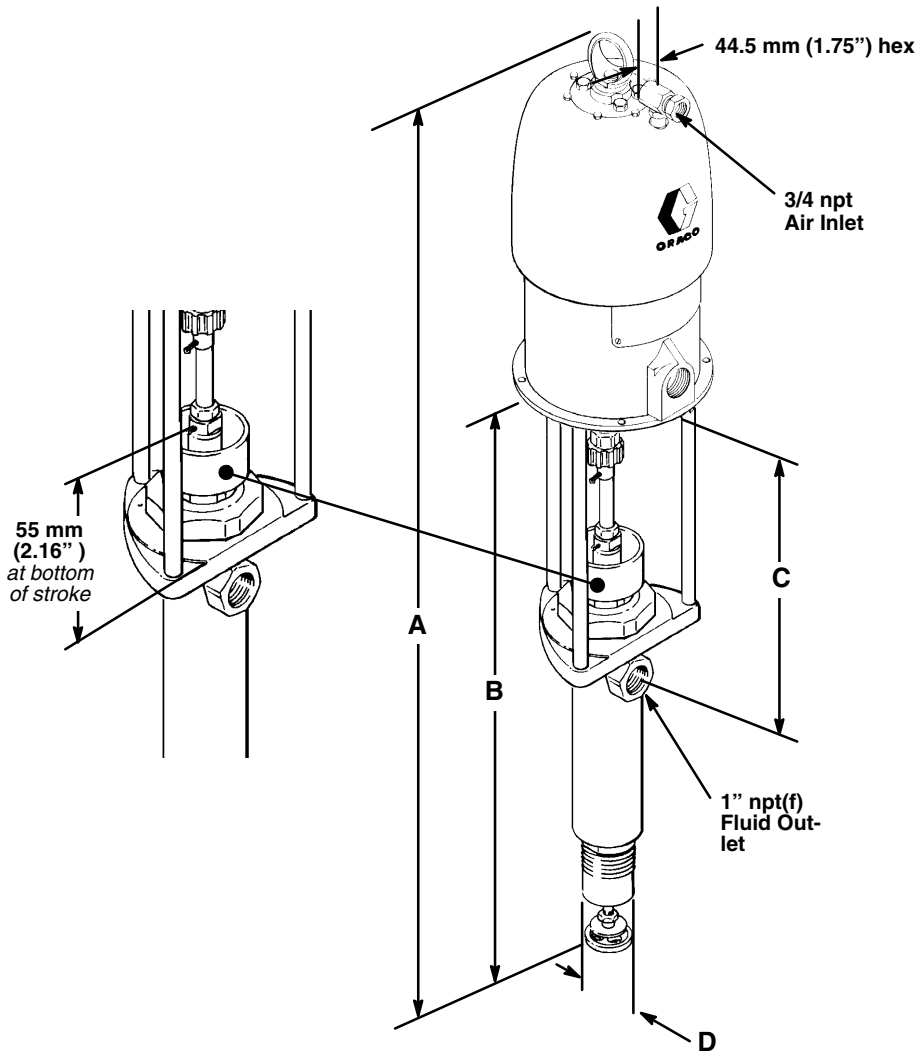

		Pump Model	
		217-566	
		222-229	
		217-565	
		220-448	
		222-228	
217-564		222-489	
220-447		222-519	
A	1194 mm (47")	1365 mm (53.75")	
B	654 mm (25.75")	826 mm (32.5")	
C	236 mm (9.3")	403 mm (15.85")	
D	68.2 mm (2.69")	68.2 mm (2.69")	

AIR MOTOR MOUNTING

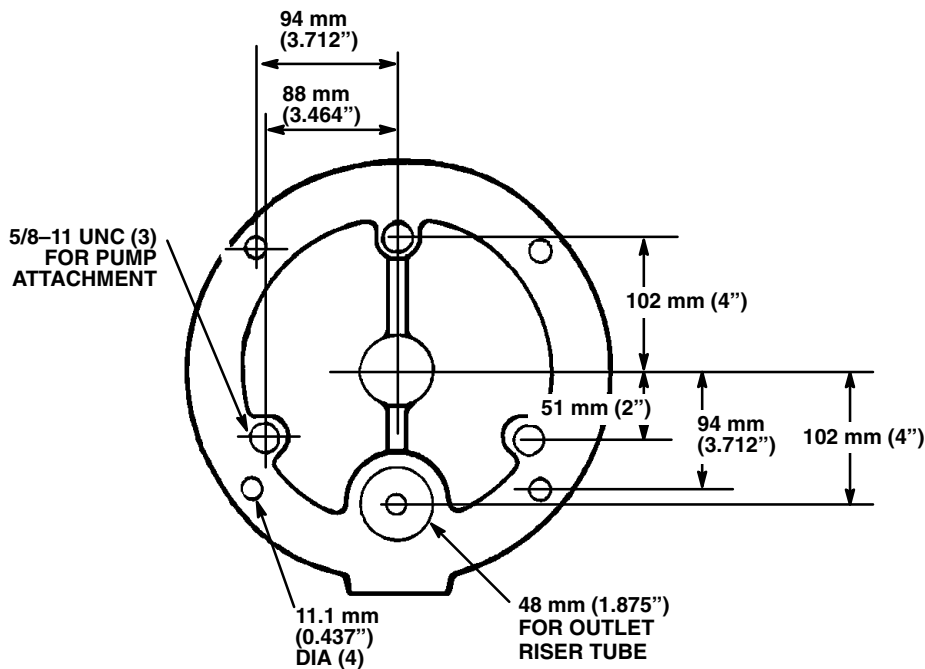

SERVICE INFORMATION

Listed below by the assembly changed are ADDED and DELETED parts.

Assembly Changed	Status	Ref No.	Part No.	Name	
Displ. Pump 217-201	DELETED	147	109-110	V-Packing	
	DELETED	148	183-858	M. Gland	
	DELETED	149	183-753	F. Gland	
	DELETED	150	109-111	V-Packing	
	DELETED	151	183-856	F. Gland	
	DELETED	154	183-859	F. Gland	
	DELETED	155	109-036	V-Packing	
	DELETED	156	109-037	V-Packing	
	DELETED	157	185-385	Shim	
	ADDED	158	223-361	Gland/ Packing Stack	
	ADDED	159	223-362	Gland/ Packing Stack	
	ADDED	160	223-363	Gland/ Packing Stack	
	Displ. Pump 220-449	DELETED	146	183-751	M. Gland
		DELETED	147	108-976	V-Packing
		DELETED	148	183-647	M. Gland
DELETED		149	183-753	F. Gland	
DELETED		150	108-977	V-Packing	
DELETED		151	183-648	F. Gland	
DELETED		152	109-034	V-Packing	
DELETED		153	109-035	V-Packing	
DELETED		154	183-752	F. Gland	
DELETED		155	109-036	V-Packing	
DELETED		156	109-037	V-Packing	
DELETED		157	185-372	Shim	
ADDED		158	223-361	Gland/ Packing Stack	
ADDED		159	223-359	Gland/ Packing Stack	
ADDED		160	223-360	Gland/ Packing Stack	

NOTE: The Gland/Packing Stacks listed above are also included in the Standard Repair Kits for these pumps, Part Nos. 222-101 and 221-156. The individual glands and packings are no longer available as separate replacement parts. The gland/packing stacks are shipped preassembled and should not be taken apart during installation in the pump.

Optional packing stacks with Leather and UHMWPE packings are also available. Refer to the parts list pages for information.

HOW TO ORDER PARTS

- 1 To be sure you receive the correct replacement parts, kits or accessories, always give all of the information requested in the chart below.
2. Check the parts list to identify the correct part number; do not use the ref. no. when ordering.
3. Order all parts from your nearest Graco distributor.

6 digit Part Number	Qty	Part Description

THE GRACO WARRANTY AND DISCLAIMERS

WARRANTY

Graco warrants all equipment manufactured by it and bearing its name to be free from defects in material and workmanship on the date of sale by an authorized Graco distributor to the original purchaser for use. As purchaser's sole remedy for breach of this warranty, Graco will, for a period of twelve months from the date of sale, repair or replace any part of the equipment proven defective. This warranty applies only when the equipment is installed, operated and maintained in accordance with Graco's written recommendations.

This warranty does not cover, and Graco shall not be liable for, any malfunction, damage or wear caused by faulty installation, misapplication, abrasion, corrosion, inadequate or improper maintenance, negligence, accident, tampering, or substitution of non-Graco component parts. Nor shall Graco be liable for malfunction, damage or wear caused by the incompatibility with Graco equipment of structures, accessories, equipment or materials not supplied by Graco, or the improper design, manufacture, installation, operation or maintenance of structures, accessories, equipment or materials not supplied by Graco.

This warranty is conditioned upon the prepaid return of the equipment claimed to be defective to an authorized Graco distributor for verification of the claim. If the claimed defect is verified, Graco will repair or replace free of charge any defective parts. The equipment will be returned to the original purchaser transportation prepaid. If inspection of the equipment does not disclose any defect in material or workmanship, repairs will be made at a reasonable charge, which charges may include the costs of parts, labor and transportation.

DISCLAIMERS AND LIMITATIONS

THE TERMS OF THIS WARRANTY CONSTITUTE PURCHASER'S SOLE AND EXCLUSIVE REMEDY AND ARE IN LIEU OF ANY OTHER WARRANTIES (EXPRESS OR IMPLIED), INCLUDING WARRANTY OF MERCHANTABILITY OR WARRANTY OF FITNESS FOR A PARTICULAR PURPOSE, AND OF ANY NON-CONTRACTUAL LIABILITIES, INCLUDING PRODUCT LIABILITIES, BASED ON NEGLIGENCE OR STRICT LIABILITY. EVERY FORM OF LIABILITY FOR DIRECT, SPECIAL OR CONSEQUENTIAL DAMAGES OR LOSS IS EXPRESSLY EXCLUDED AND DENIED. IN NO CASE SHALL GRACO'S LIABILITY EXCEED THE AMOUNT OF THE PURCHASE PRICE. ANY ACTION FOR BREACH OF WARRANTY MUST BE BROUGHT WITHIN TWO (2) YEARS OF THE DATE OF SALE.

EQUIPMENT NOT COVERED BY GRACO WARRANTY

GRACO MAKES NO WARRANTY, AND DISCLAIMS ALL IMPLIED WARRANTIES OF MERCHANTABILITY AND FITNESS FOR A PARTICULAR PURPOSE, WITH RESPECT TO ACCESSORIES, EQUIPMENT, MATERIALS, OR COMPONENTS SOLD BUT NOT MANUFACTURED BY GRACO. These items sold, but not manufactured by Graco (such as electric motor , switches, hose, etc.) are subject to the warranty, if any, of their manufacturer. Graco will provide purchaser with reasonable assistance in making any claim for breach of these warranties.

GRACO PRODUCT SERVICE: 1-800-543-0339

Factory Branches: Atlanta, Chicago, Dallas, Detroit, Los Angeles, West Caldwell (N.J.)

Subsidiary and Affiliate Companies: Canada; England; Switzerland; France; Germany; Hong Kong; Japan

GRACO INC. P.O. BOX 1441 MINNEAPOLIS, MN 55440-1441

PRINTED IN U.S.A. 307-605 2-85 Revised 1-90