



This manual contains important warnings and information.
READ AND KEEP FOR REFERENCE.

INSTRUCTIONS

First choice when quality counts.™

GH 733 HYDRA-SPRAY® SPRAYER

3500 psi (240 bar, 24 MPa) MAXIMUM WORKING PRESSURE

U.S. Patent Pending

Model 231733, Series D

Sprayer only. Has Severe-Duty* Displacement Pump

Model 230975

Includes Sprayer 231733, Hose, Swivel, Gun, RAC® IV, DripLess™ Tip Guard and SwitchTip™

*Severe-duty displacement pumps have an abrasion and corrosion-resistant displacement rod and sleeve. Refer to the Technical Data in manual 307862.

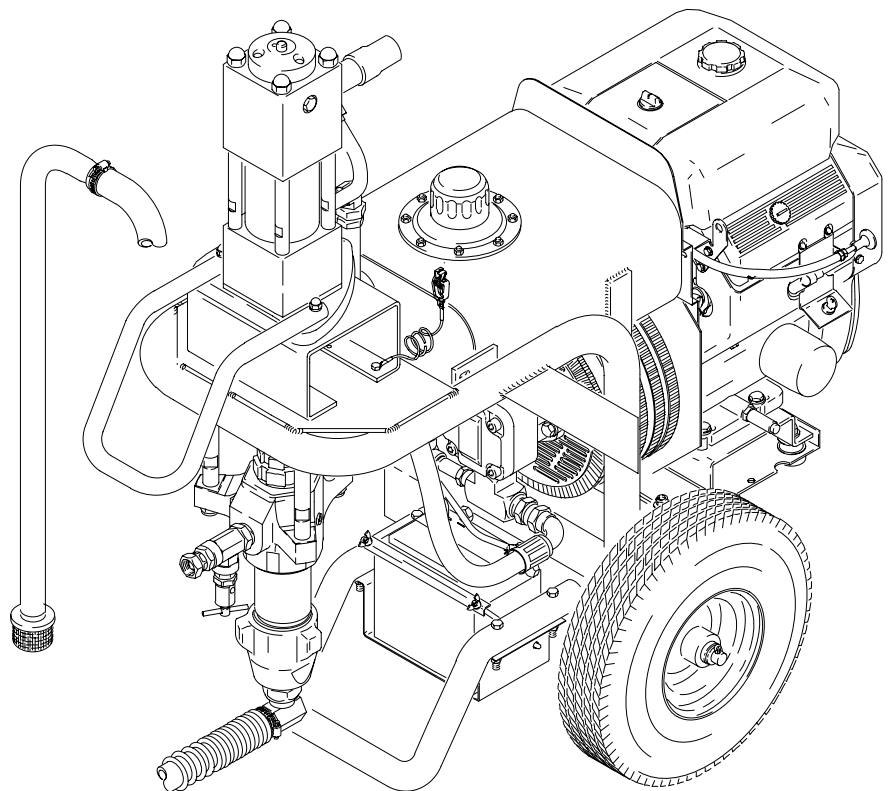

9089B

GRACO INC. P.O. BOX 1441 MINNEAPOLIS, MN 55440-1441

©COPYRIGHT 1983, GRACO INC.

Graco Inc. is registered to I.S. EN ISO 9001

Table of Contents

Warnings	2	Complete Sprayer Parts Drawing	17
Component Identification	5	GH733 Sprayer Parts Drawing	18
Setup	5	GH733 Sprayer Parts List	21
Flushing	8	Accessories	23
Operation	10	Technical Data	23
Maintenance	12	Graco Phone Number	23
Troubleshooting	13	Graco Warranty	24
Displacement Pump Service	16		

Symbols

Warning Symbol



This symbol alerts you to the possibility of serious injury or death if you do not follow the instructions.

Caution Symbol



This symbol alerts you to the possibility of damage to equipment if you do not follow the instructions.

WARNING



INSTRUCTIONS

EQUIPMENT MISUSE HAZARD

Equipment misuse can cause the equipment to rupture or malfunction and result in serious injury.

- This equipment is for professional use only.
- Read all instruction manuals, tags, and labels before operating the equipment.
- Use the equipment only for its intended purpose. If you are not sure, call your Graco distributor.
- Do not alter or modify this equipment. Use only genuine Graco parts.
- Check equipment daily. Repair or replace worn or damaged parts immediately.
- Do not exceed the maximum working pressure of the lowest rated system component. Refer to the **Technical Data** on page 23 for the maximum working pressure of this equipment.
- Use fluids and solvents which are compatible with the equipment wetted parts. Refer to the **Technical Data** section of all equipment manuals. Read the fluid and solvent manufacturer's warnings.
- Do not use hoses to pull equipment.
- Route hoses away from traffic areas, sharp edges, moving parts, and hot surfaces. Do not expose Graco hoses to temperatures above 82°C (180°F) or below -40°C (-40°F).
- Do not lift pressurized equipment.
- Comply with all applicable local, state, and national fire, electrical, and safety regulations.
- Wear hearing protection when operating this equipment.
- Do not use 1,1,1-trichloroethane, methylene chloride, other halogenated hydrocarbon solvents or fluids containing such solvents in pressurized aluminum equipment. Such use could result in a chemical reaction, with the possibility of explosion.

WARNING



INJECTION HAZARD

Spray from the gun, leaks or ruptured components can inject fluid into your body and cause extremely serious injury, including the need for amputation. Fluid splashed in the eyes or on the skin can also cause serious injury.

- Fluid injected into the skin may look like just a cut, but it is a serious injury. **Get immediate medical attention.**
- Do not point the gun at anyone or at any part of the body.
- Do not put your hand or fingers over the spray tip.
- Do not stop or deflect leaks with your hand, body, glove or rag.
- Do not “blow back” fluid; this is not an air spray system.
- Always have the tip guard and the trigger guard on the gun when spraying.
- Check the gun diffuser operation weekly. Refer to the gun manual.
- Be sure the gun trigger safety operates before spraying.
- Lock the gun trigger safety when you stop spraying.
- Follow the **Pressure Relief Procedure** on page 10 if the spray tip clogs and before cleaning, checking or servicing the equipment.
- Tighten all fluid connections before operating the equipment.
- Check the hoses, tubes, and couplings daily. Replace worn or damaged parts immediately. Do not repair high pressure couplings; you must replace the entire hose.
- Fluid hoses must have spring guards on both ends, to help protect them from rupture caused by kinks or bends near the couplings.



TOXIC FLUID HAZARD

Hazardous fluid or toxic fumes can cause serious injury or death if splashed in the eyes or on the skin, inhaled, or swallowed.

- Know the specific hazards of the fluid you are using.
- Store hazardous fluid in an approved container. Dispose of hazardous fluid according to all local, state and national guidelines.
- Always wear protective eyewear, gloves, clothing and respirator as recommended by the fluid and solvent manufacturer.



FUEL HAZARD

The fuel used in this unit is combustible and when spilled on a hot surface can ignite and cause a fire.

- Do not fill the fuel tank while the engine is running or hot.



EXHAUST HAZARD

The exhaust contains poisonous carbon dioxide which is colorless and odorless.

- Do not operate this equipment in a closed building.

⚠ WARNING



FIRE AND EXPLOSION HAZARD

Improper grounding, poor ventilation, open flames or sparks can cause a hazardous condition and result in a fire or explosion and serious injury.



- If there is any static sparking or you feel an electric shock while using this equipment, **stop spraying immediately**. Do not use the equipment until you identify and correct the problem.
- Provide fresh air ventilation to avoid the buildup of flammable fumes from solvents or the fluid being sprayed.
- Keep the spray area free of debris, including solvent, rags, and gasoline.
- Disconnect all electrical equipment in the spray area.
- Extinguish all open flames or pilot lights in the spray area.
- Do not smoke in the spray area.
- Do not turn on or off any light switch in the spray area while operating or if fumes are present.
- Do not operate a gasoline engine in the spray area.
- Ground the sprayer to a true earth ground with the ground wire and clamp (supplied).
- Use only electrically conductive hoses.



MOVING PARTS HAZARD

Moving parts can pinch or amputate your fingers.

- Keep clear of all moving parts when starting or operating the sprayer.
- Before servicing the equipment, follow the **Pressure Relief Procedure** on page 10 to prevent the equipment from starting unexpectedly.

NOTE: This is an example of the DANGER label on your sprayer. This label is available in other languages, free of charge. See page 23 to order.

⚠ DANGER ⚠			
	FIRE AND EXPLOSION HAZARD		SKIN INJECTION HAZARD
<p>Spray painting, flushing or cleaning equipment with flammable liquids in confined areas can result in fire or explosion. Use outdoors or in extremely well ventilated areas. Ground equipment, hoses, containers and objects being sprayed. Avoid all ignition sources such as static electricity from plastic drop cloths, open flames such as pilot lights, hot objects such as cigarettes, arcs from connecting or disconnecting power cords or turning light switches on and off. Failure to follow this warning can result in death or serious injury.</p>	<p>Liquids can be injected into the body by high pressure airless spray or leaks – especially hose leaks. Keep body clear of the nozzle. Never stop leaks with any part of the body. Drain all pressure before removing parts. Avoid accidental triggering of gun by always setting safety latch when not spraying. Never spray without a tip guard. In case of accidental skin injection, seek immediate “Surgical Treatment”. Failure to follow this warning can result in amputation or serious injury.</p>	READ AND UNDERSTAND ALL LABELS AND INSTRUCTION MANUALS BEFORE USE	

Component Identification

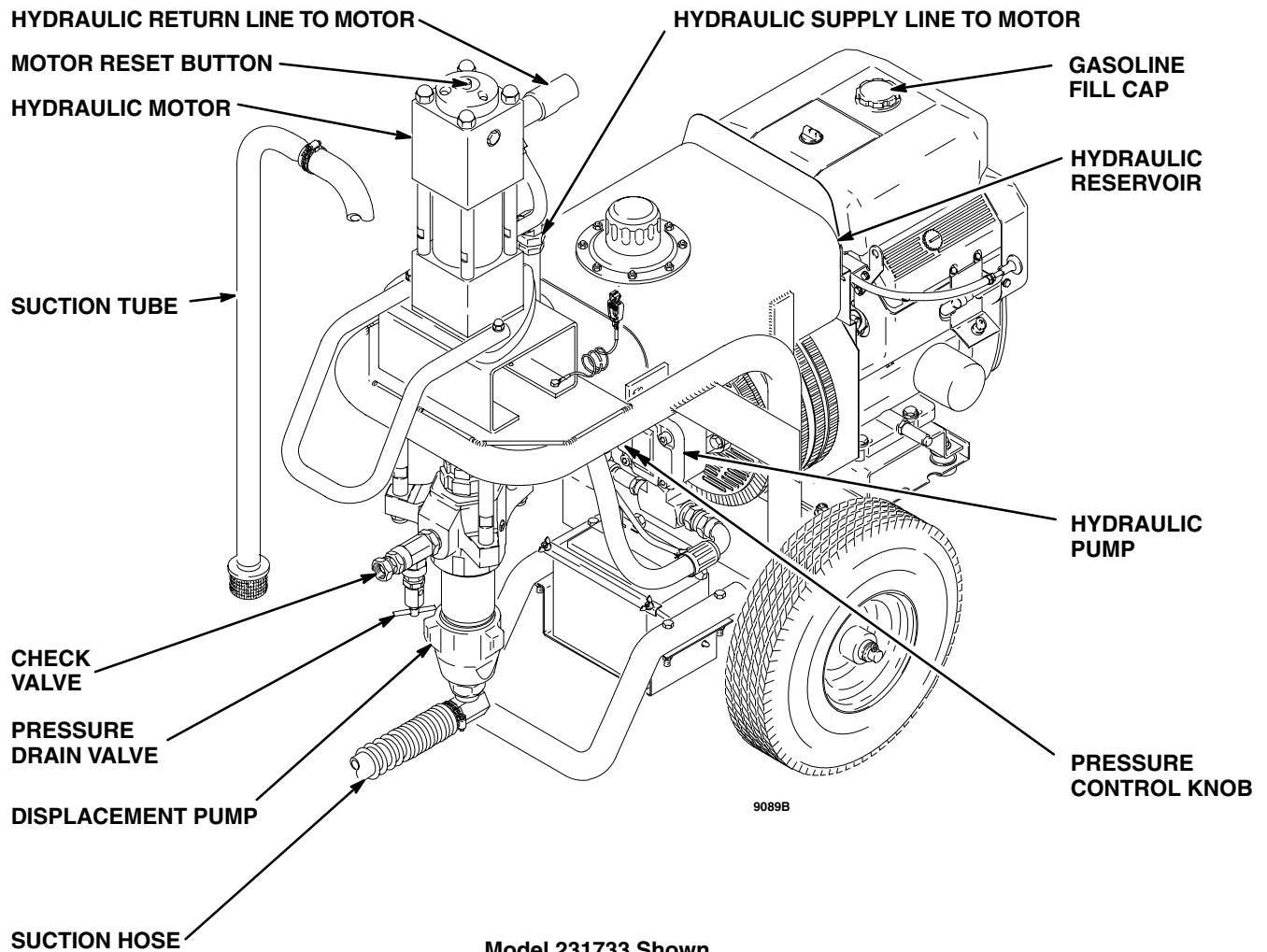

Fig 1

Setup

1. Connect the Hose and Gun

- Remove the plastic cap plug from the outlet tee and screw an accessory, conductive or grounded spray hose onto the 1/4 npsm(f) outlet nipple. See Fig 1.
- Connect a small diameter, 3 ft (0.9 m) whip hose between the main hose and a spray gun, if desired, for more flexible gun movement. See Fig 1.

- Don't use thread sealant on the swiveling nut of the hose couplings, and **don't install the spray tip yet.**

NOTE: Use thread sealant on all male threads except at swivel unions. Swivel unions are made to self-seal, and using thread sealant prevents the swivel from turning freely.

- Fill the Packing Nut/Wet Cup** 1/3 full with Graco Throat Seal Liquid (TSL), supplied. See Fig. 2.

Setup

3. Check the Hydraulic Oil Level

- a. Unscrew the hydraulic oil fill cap. See Fig 2. The dipstick is attached to the cap. The oil should be up to the full line on the dipstick.

⚠ CAUTION

To prevent damage to the cooling system and hydraulic pump, use *only* Graco Hydraulic Oil, 169236 (5 gal./20 liter) or 207428 (1 gal/3.8 liter). Other types of hydraulic oil may damage the hydraulic components.

- b. Add oil as needed to the proper level. A completely full hydraulic system contains about 5 gallons (20 liters) of oil.

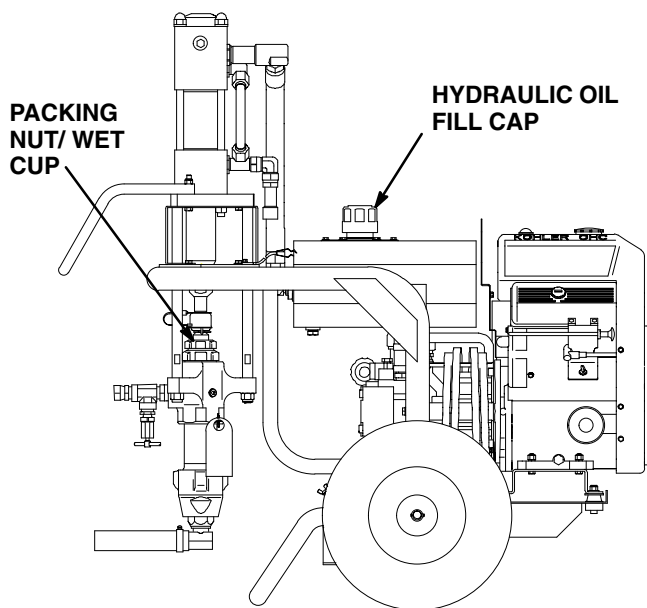

Fig 2 7871b

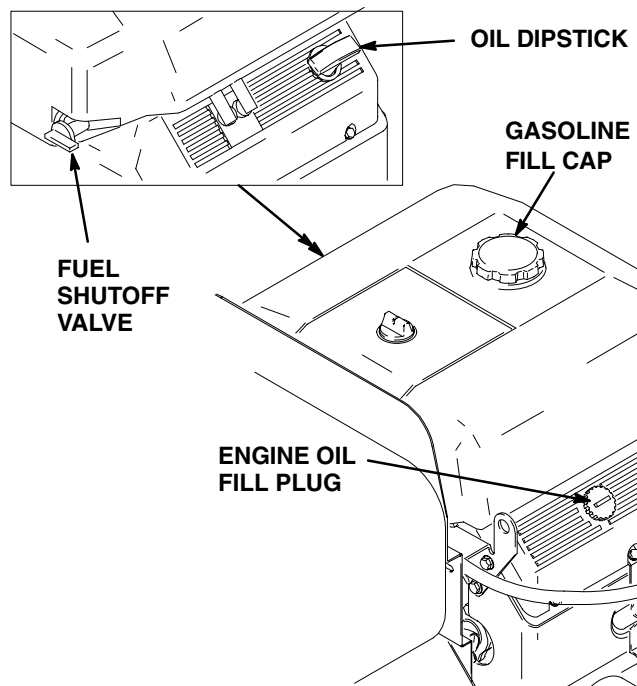

Fig 3 7872A

4. Check the Engine Oil Level

- a. Remove the dipstick. See Fig 3.
- b. Check to be sure the oil is up to the full mark on the dipstick.
- c. If oil is needed, see the chart below for the recommended oil type and weight.
- d. Crank case capacity: 1.5 quarts (1.4 liters)

RECOMMENDED LUBRICATION OIL: Use a high quality detergent oil of American Petroleum Institute (API) service class SG or SH for regular use and for breaking in a new engine.

GRADE OF OIL CHART	
SEASON OR TEMPERATURE	GRADE OF OIL
Spring, Summer, Autumn	SAE 10W-30
30°F to 0°, Winter	SAE 5W-20 or 10W-20

Setup

5. Fill the Fuel Tank

⚠ WARNING



FIRE AND EXPLOSION HAZARD
Fuel spilled on a hot surface can cause a fire or explosion and serious bodily injury and property damage. Shut off engine and let it cool before filling the tank. Carefully follow steps 5.a. to 5.c., below, being sure not to spill any fuel.

- a. Close the fuel shutoff valve. See Fig 3.
- b. Use only clean, fresh, well-known brands of *unleaded regular grade gasoline*. The minimum octane requirements are 87 octane in the U.S.A. and 96 octane elsewhere.
- c. Remove the gasoline fill cap and fill the tank. Be sure the air vent in the fill cap is not plugged so gasoline can flow to the carburetor, then replace the cap. See Fig 3.
- d. Fuel tank capacity: 1.7 gallons (6.5 liters)
- e. Gasoline consumption at the maximum operating speed of 2900 RPM is about 1.3 gallons/hour (4.9 liters/hour).

6. Grounding

⚠ WARNING



FIRE AND EXPLOSION HAZARD
To reduce the risk of static sparking, fire or explosion which can result in serious bodily injury and property damage, ground the sprayer, all system components, and the object being sprayed as instructed under **FIRE OR EXPLOSION HAZARD** on page 3.

Connect the ground wire and clamp (provided) to a true earth ground. See Fig 4.

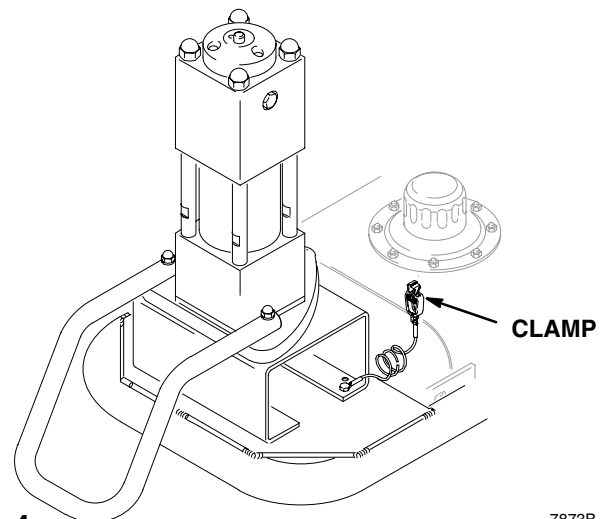

Fig 4

7873B

7. **Flush the sprayer** to remove the oil which was left in the pump after factory testing to protect the pump from corrosion. See **Flushing**.
8. **Battery Maintenance**

Always charge a new battery or a battery that has not been in use for a long period.

Flushing

When to Flush

1. **New sprayer.** Your new sprayer was factory tested with lightweight oil which was left in to protect pump parts from corrosion.
Before using oil-base paint, flush with mineral spirits only.
Before using water-base paint, flush with mineral spirits, followed by soapy water, then a clean water rinse.
2. **Changing colors.** Flush with a compatible solvent such as mineral spirits.
3. **Changing from water-base to oil-base paint.** Flush with soapy water, then mineral spirits.

4. **Changing from oil-base to water-base paint.** Flush with mineral spirits, followed by soapy water, then a clean water flush.
5. **Storage.**
Water-base paint: flush with water, then mineral spirits and leave the pump, hose and gun filled with mineral spirits. Follow the **Pressure Relief Procedure Warning**, page 10.
Oil-base paint: flush with mineral spirits. Follow the **Pressure Relief Procedure Warning**, page 10.
6. **Startup after storage.**
Before using water-base paint, flush out mineral spirits with soapy water and then clean water.
When using oil-base paint, flush out mineral spirits with fluid to be sprayed.

How to Flush

WARNING



INJECTION HAZARD

Follow the **Pressure Relief Procedure Warning** on page 10. Remove the spray tip before flushing.

1. Engage the gun safety latch. Remove the spray tip from the gun.
2. Pour enough clean, compatible solvent to fill the pump and hoses into a large, grounded metal pail.
3. Place the suction tube into the pail or tilt the sprayer back (it will support itself) and place the pail under the pump. Then tilt the sprayer forward to lower the pump into the pail.
4. Turn the pressure control knob *counterclockwise* until all spring tension is relieved. You will be able to feel it. The sprayer is now set at the lowest pressure setting. Turning the knob further will remove it. Tighten the knob locknut to set. See Fig 5.
5. Open the bypass valve. The valve lever will be parallel to the body of the valve. See Fig 5.
6. Open the fuel shutoff valve by turning it to horizontal. See Fig 5.
7. Close the choke by pulling out on the choke head. See Fig 5.

CAUTION

The bypass valve must be opened when starting the sprayer to prevent damaging the starter.

8. Turn and hold the ignition key to START until you hear the engine "catch", then release the key to RUN. See Fig 5. If the engine does not start, open the choke a little (push in on head). If the engine floods, open the choke all the way and try again.

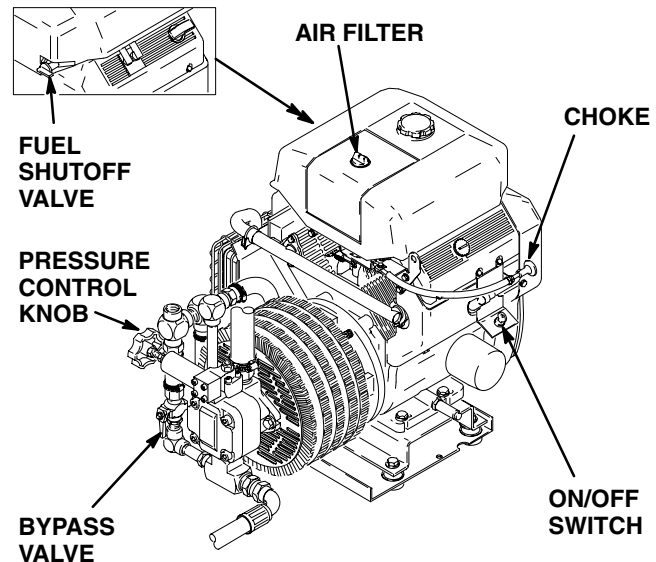

Fig 5

7874A

9. After the engine is warm, gradually open the choke lever (push choke head in completely) and close the bypass valve. See Fig 5.
10. Point the gun into the grounded metal pail and hold a metal part of the gun firmly against the pail.

NOTE: To save the fluid in the pump and hose, trigger the gun into the paint container or a separate clean container. At the same time, slowly turn the pressure control knob clockwise just enough to start the pump. When solvent appears, release the trigger and continue as below.

Flushing

WARNING



FIRE AND EXPLOSION HAZARD

To reduce the risk of static sparking and splashing when flushing, always remove the spray tip from the gun and hold a metal part of the gun firmly to the side of a grounded metal pail.

11. Making firm metal-to-metal contact, hold the gun firmly to the side of the grounded solvent pail. Trigger the gun. At the same time, slowly turn the pressure control knob clockwise just enough to start the pump.
12. Circulate the solvent until the system is thoroughly flushed.
13. Release the trigger and engage the gun safety latch.
14. **If you are going to start spraying**, place the pump or suction tube into the supply container. Follow the **Pressure Relief Procedure** on page 10. Engage the gun safety latch until you are ready to prime the pump. See Step 3, page 9.
15. **If you are going to store the sprayer**, be sure your final flush is with an oil-based solvent, such as mineral spirits. Remove the suction tube or pump from the solvent pail. Follow the **Pressure Relief Procedure** on page 10. Engage the gun safety latch, but leave the drain valve open.

Operation

Pressure Relief Procedure

WARNING



INJECTION HAZARD

The system pressure must be manually relieved to prevent the system from starting or spraying accidentally. Fluid under high pressure can be injected through the skin and cause serious injury. To reduce the risk of an injury from injection, splashing fluid, or moving parts, follow the **Pressure Relief Procedure** whenever you:

- are instructed to relieve the pressure,
- stop spraying,
- check or service any of the system equipment,
- install or clean the spray tip.

1. Engage the gun safety latch.
2. Open the bypass valve.
3. Turn the ignition key to OFF.
4. Close the fuel shutoff valve.
5. Disengage the gun safety latch. Hold a metal part of the gun firmly to the side of a grounded metal pail, and trigger the gun to relieve pressure.
6. Engage the gun safety latch.
7. Open the pressure drain valve, having a container ready to catch the drainage. Leave the valve open until you are ready to spray again.

If you suspect that the spray tip or hose is completely clogged, or that pressure has not been fully relieved after following the steps above, wrap a rag around the tip guard retaining nut or hose end coupling and VERY SLOWLY loosen the part to relieve pressure gradually, then loosen completely. Now clear the tip or hose.

1. Prepare the Fluid

- a. Prepare the fluid according to the fluid manufacturer's recommendations.
- b. Place the pump or suction tube into the fluid container.

2. Starting the Sprayer

- a. Open the bypass valve to make startup easier. In the open position, the valve lever is parallel to the body of the valve. See Fig 6. Close the filter drain valve.
 - b. Turn the pressure control knob *counterclockwise* until all spring tension is relieved. You will be able to feel it. The sprayer is now set at the lowest pressure setting. Turning the knob further will cause it to fall off.
 - c. Open the fuel shutoff valve. See Fig 6.
 - d. If the engine is cold, close the choke by turning the lever to the ON position (horizontal). See Fig 6.
3. Turn and hold the ignition key to START until you hear the engine "catch", then release the key to RUN. See Fig 6. If the engine does not start, open the choke a little (push the choke head in). If the engine floods, open the choke all the way and try again.
 - e. After the engine is warm, gradually open the choke lever (push choke head in completely) and close the bypass valve. See Fig 6.

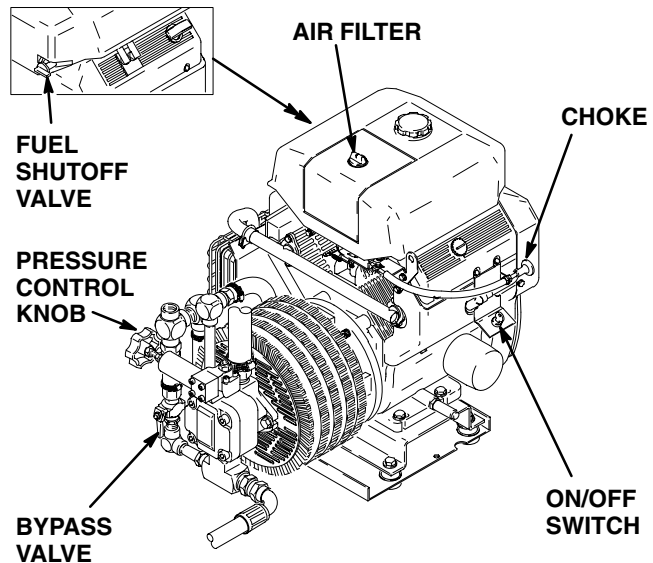

Fig 6

7874A

NOTE: In cold weather, run the engine for about 15 minutes with the bypass valve open before starting the displacement pump, to help avoid hydraulic motor stalling.

- f. Follow the **Pressure Relief Procedure Warning** on page 10, to shut off the sprayer.

WARNING

To stop the engine in an emergency, turn OFF the ignition key. Close the bypass valve if possible. See Fig 6. Then follow the **Pressure Relief Procedure Warning on page 10.**

Operation

If the motor stalls during operation, turn OFF the ignition key. With your hand, firmly press straight down on the motor reset button. Now try to restart the sprayer. If it will not start, refer to the separate motor manual, 307158.

⚠ CAUTION

Never use a hammer to depress the reset button, as it could cause serious internal motor damage.

4. Prime the Pump

- Be sure the gun safety latch is engaged.
- Don't install the spray tip yet!
- If the engine has not been started, follow the procedure in Step 2., page 10.
- Disengage the gun safety latch.
- Point the gun into a grounded metal pail and hold a metal part of the gun *firmly* against the pail. See the WARNING below.
- Squeeze the trigger and *slowly* turn the pressure control knob *clockwise* just enough to start the pump. See Fig 6.
- Operate the pump until all air is purged from the pump and hoses and the fluid is flowing freely from the gun.
- Release the trigger and engage the safety latch.
- Turn the pressure control knob *counterclockwise* until all spring tension is relieved. You will be able to feel it. The sprayer is now at the lowest pressure setting. Turning the knob further will remove it.
- Follow the **Pressure Relief Procedure** on page 10. Then install the spray tip in the gun as instructed in the separate gun or tip instruction manual. If you are using the RAC IV sprayer, see manual 308644.

5. Adjusting the Pressure

- Turn the pressure control knob *clockwise* to increase and *counterclockwise* to decrease the pressure. Tighten the knob locknut to set.
- Always use the lowest pressure that is necessary to completely atomize the fluid.

⚠ CAUTION

Operating the sprayer at a higher pressure than necessary wastes fluid, causes early tip wear, and shortens the sprayer life.

- If more coverage is needed, use a larger tip rather than increasing the pressure.
- Check the spray pattern. The tip size and angle determines the pattern width and flow rate. See the separate manual received with your gun.

⚠ CAUTION

The engine throttle has been set and locked at 3000 RPM. The sprayer warranty will be voided and the hydraulic pump life shortened if this adjustment is changed.

6. Cleaning a Clogged Tip

⚠ WARNING



INJECTION HAZARD

To reduce the risk of a fluid injection injury, NEVER hold your hand, body or a rag in front of the spray tip when cleaning or checking for a cleared tip. To reduce the risk of a fire or explosion, always hold the gun firmly against the side of a grounded metal waste container when checking to see if the tip was cleared or when using a self-clearing tip.

- Follow the **Pressure Relief Procedure Warning** on page 10.
- Clean the front of the tip frequently during the day to keep the fluid from building up and clogging the tip. To clean, and to clear a tip if it clogs, refer to your separate gun instruction manual. If you are using the RAC IV tip guard and SwitchTip, refer to manual 308644.

7. Shutting Off the Sprayer

- Whenever you stop spraying, even for a short break, follow the **Pressure Relief Procedure Warning** on page 10.
- Clean the tip and gun as recommended in your separate gun or tip manual.
- Flush the sprayer at the end of each work day if using water-based fluid or if it could harden in the sprayer over night. See **FLUSHING**, page 8. Use a compatible solvent to flush, then fill the pump and hoses with solvent such as mineral spirits to help prevent pump corrosion. **Relieve pressure!**
- For long term shutdown or storage, *always* fill the sprayer with mineral spirits to prevent pump corrosion. **Relieve pressure!**

8. Adjusting the Intake Valve Ball Travel.

- The pump is set to handle medium volume, low viscosity fluid. To adjust the pump for higher flow or heavier viscosity fluid, disassemble the intake valve as instructed in manual 309340 and move the ball stop pin to a higher set of holes. This increases the ball travel.

Maintenance

1. **Always stop the pump at the bottom of its stroke** when you take a break and at the end of the day. This helps keep fluid from drying on the rod and damaging the packings.
2. **Keep the displacement pump packing nut/wet cup 1/3 full of TSL** at all times. The TSL helps protect the packings and rod.
3. **Check the tightness of the packing nut daily.** It should be tight enough to stop leakage but no tighter.

⚠ CAUTION

Proper engine and hydraulic oil level is important to prevent costly damage to the sprayer. Check it as often as recommended in Steps 4 and 5., below.

4. **Check the hydraulic oil level weekly.** The oil must be up to the top mark on the dipstick. Use only Graco Hydraulic Oil.
5. **Check the engine oil level at least weekly.** The oil must be up to the FULL mark on the dipstick. The engine should not use more than one ounce of oil per hour of operation. Consult the engine manual, supplied, for additional recommended maintenance.
6. **Inspect the return line filter frequently** for clogging. Replace it after every 500 hours of operation or every 6 months, whichever comes first. A clogged or worn out filter reduces filter capability and will damage the hydraulic pump.
7. **Check the battery water level** periodically and refill as necessary.
8. **Change the hydraulic oil after every 2000 hours** of operation or every 12 months, whichever comes first. For continuous operation in temperatures above 85°F (30°C), change the oil after every 1000 hours or 6 months of use. See Step 9. for the procedure.

⚠ CAUTION

Cleanliness is essential when servicing the hydraulic system. Use special care to avoid getting dust or dirt into the hydraulic system to prevent damage to the hydraulic components.

9. **To change the hydraulic oil:**
 - a. Follow the **Pressure Relief Procedure Warning** on page 10.
 - b. Place a waste container under the drain plug of the hydraulic reservoir. See Fig 7. Unscrew the plug and drain the reservoir. Reinstall the plug before proceeding.
 - c. Remove the nuts and reservoir cover.
 - d. Remove the return line filter and install a new filter assembly.
 - e. Inspect the inlet filter and replace it if needed.
 - f. Install the reservoir cover and nuts. Then pour in five gallons (19 liters) of Graco Hydraulic Oil through the intake filter. See Fig 7. Install the fill cap.

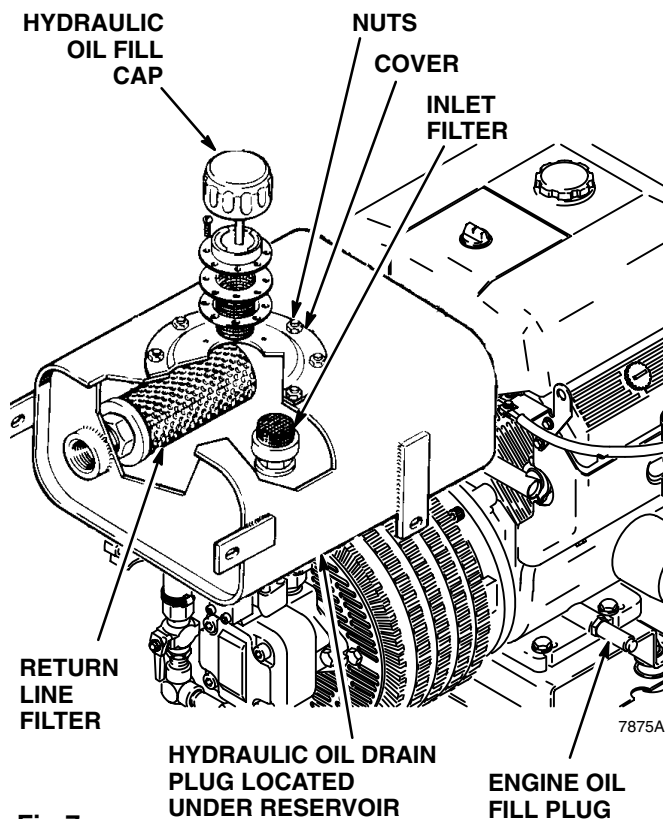

Fig 7

Troubleshooting

⚠ WARNING



INJECTION HAZARD

To reduce the risk of serious injury, whenever you are instructed to relieve pressure, follow the **Pressure Relief Procedure** on page 10.

Check everything in the troubleshooting chart before disassembling the sprayer.

PROBLEM	CAUSE	SOLUTION
Gas engine doesn't work properly.		Consult engine manual, supplied.
Gas engine will not start.		Check battery.
Gas engine operates, but displacement pump doesn't operate.	<p>Hydraulic motor stalled.</p> <p>Pressure setting too low.</p> <p>Displacement pump outlet filter (if used) is dirty or clogged.</p> <p>Tip or tip filter (if used) is clogged.</p> <p>Hydraulic fluid too low.</p> <p>Hydraulic pump worn or damaged.</p> <p>Hydraulic motor worn or damaged.</p> <p>Displacement pump rod seized by dried paint.</p>	<p>Turn the ignition key to OFF. Firmly press straight down on motor reset button. Restart sprayer, see page 10. If it doesn't start, see manual 307158.</p> <p>Increase pressure. See page 11.</p> <p>Clean the filter.</p> <p>Remove tip and/or filter and clean.</p> <p>Shut off sprayer and add fluid immediately*. See page 5.</p> <p>Return sprayer for repair.</p> <p>Return sprayer for repair.</p> <p>Service pump. See manual 309340.</p>
Displacement pump operates, but output is low on upstroke.	<p>Piston ball check not seating properly.</p> <p>Piston packings worn or damaged.</p>	<p>Service piston ball check. See manual 309340.</p> <p>Replace packings. See manual 309340.</p>
Displacement pump operates but output is low on downstroke and/or on both strokes.	<p>Piston packings worn or damaged.</p> <p>Intake valve ball check not seating properly.</p>	<p>Replace packings. See manual 309340.</p> <p>Service intake valve ball check. See manual 309340.</p>
Paint leaks into wetcup	<p>Loose wet-cup</p> <p>Throat packings worn or damaged.</p>	<p>Tighten just enough to stop leakage.</p> <p>Replace packings. See manual 309340.</p>
Excessive leakage around hydraulic motor piston rod wiper.	<p>Piston rod seal worn or damaged.</p>	<p>Replace these parts. See manual 307158.</p>
Fluid delivery is low.	<p>Pressure setting too low.</p> <p>Displacement pump outlet filter (if used) is dirty or clogged.</p> <p>Hydraulic pump is worn or damaged.</p> <p>Hydraulic motor is worn or damaged.</p> <p>Large pressure drop in fluid hose.</p>	<p>Increase pressure. See page 11.</p> <p>Clean filter</p> <p>Return sprayer for repair.</p> <p>Return sprayer for repair.</p> <p>Use larger diameter hose.</p>
The sprayer overheats.	<p>Cooler or blower is worn or damaged.</p>	<p>Replace. See page 15.</p>
Spitting from gun.	<p>Air in fluid pump or hose.</p> <p>Fluid supply is low or empty.</p>	<p>Check for loose connections on siphon assembly, tighten, then reprime pump.</p> <p>Refill supply container.</p>

*Check hydraulic fluid level often. Do not allow it to become too low. Use only Graco approved hydraulic fluid. See pages 5 and 20.

Replacing the Hydraulic Pump

1. Follow the **Pressure Relief Procedure Warning** on page 10. Let the hydraulic system cool before beginning the service procedure.
2. Unscrew the reservoir drain plug (51), having a container ready to catch the draining fluid.
3. Disconnect the hose (7) from the bypass valve (9) by loosening the hose clamp (8). See Fig 8.
4. Loosen the hose clamp (8) and pull the hose (85) off the hose insert (5) near the elbow (3). See Fig 8.
5. Loosen the hose clamp (54) on the hose (53) just above the hydraulic pump (107). See Fig 8.
6. Loosen the tube fitting nut (18) of hose (22). See Fig 8.
7. Remove the two capscrews (150), lockwashers (66) and washers (64) holding the pump (107) to the support (117). See Fig 8.

8. Pull the pump straight off the pump support.
9. Loosen the setscrews (108) on the pump half of the coupler (109). See Fig 9.
10. Remove all fittings from the old pump and install them on the new pump in the same order.
11. Check Dimension A as shown in Fig 9. When the dimension is correct, tighten the setscrews (108), slide the new pump assembly onto the pump support (117) and recheck the dimension.

CAUTION

The correct coupling dimension is critical to avoid improper coupler engagement to the coupler spider which will damage the coupler and make the sprayer inoperable.

12. Reconnect the hoses. Reinstall the reservoir plug (51), and refill the reservoir with clean, Graco approved hydraulic oil.

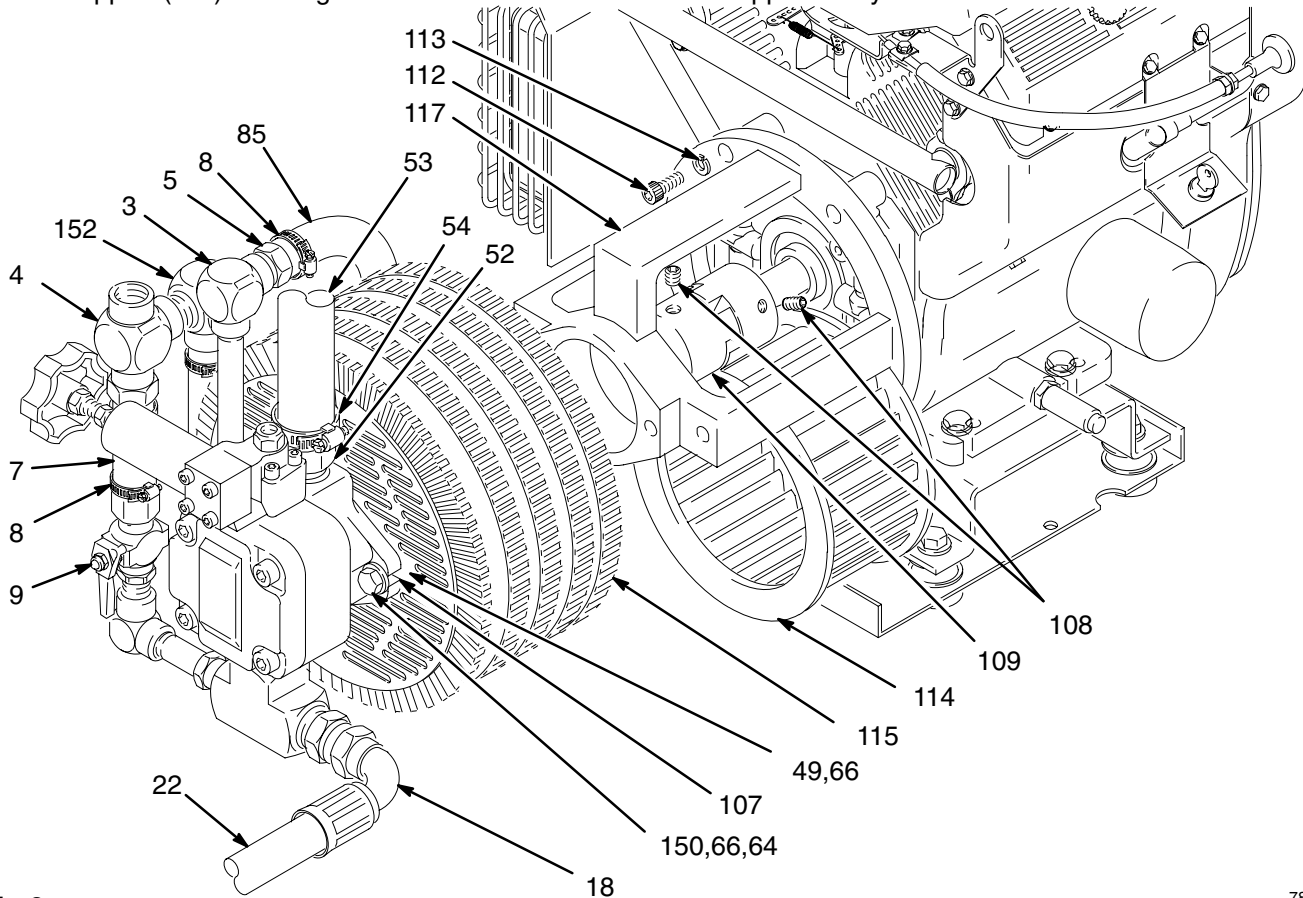

Fig 8

7876A

Replacing the Cooler and Blower

1. Follow the **Pressure Relief Procedure Warning** on page 10. Let the hydraulic system cool before beginning the service procedure.
2. Remove the hydraulic pump as instructed in the previous section.
3. Disconnect the cooler to reservoir return hose (7.) by loosening the hose clamp (8). See Fig 8.
4. Remove the cooler capscrews (49) and lockwashers (66). See Fig 8.
5. Remove the fan guard (23). See Fig 8.
6. Pull the cooler (115) straight out.
7. Inspect the rubber pad (116) for wear and replace if necessary. See Fig 9.
8. Inspect the blower wheel (114) for wear. See Fig 8. If it needs to be replaced, follow Steps 8a–8e.
 - a. Unscrew the setscrews (108) from the engine half of the coupler (109). Unscrew the blower setscrews (B). See Fig 9.
 - b. Remove the capscrews (112) and lockwashers (113) holding the pump support (117) to the engine and pull the support off. See Fig 8.
 - c. Pull the pump support and blower off far enough for the blower to fall out of the bottom of the housing.
 - d. Install a new blower. Secure the pump support (117) to the engine. See Fig 8.
 - e. Check Dimension A as shown in Fig 9 and tighten the coupler setscrews (108). Butt the blower hub up to the coupler half, keeping the blower in full contact with the coupler, and tighten the blower setscrews (B).
9. Install the cooler.
10. Fold the flaps of the pad (116) toward the cooler fins and install the fan guard (23), capscrews (49) and lockwashers (66). See Fig 8.
11. Reinstall the hydraulic pump and reconnect all hoses.

CAUTION

The correct coupling dimension is critical to avoid improper coupler engagement to the coupler spider which will damage the coupler and make the sprayer inoperable.

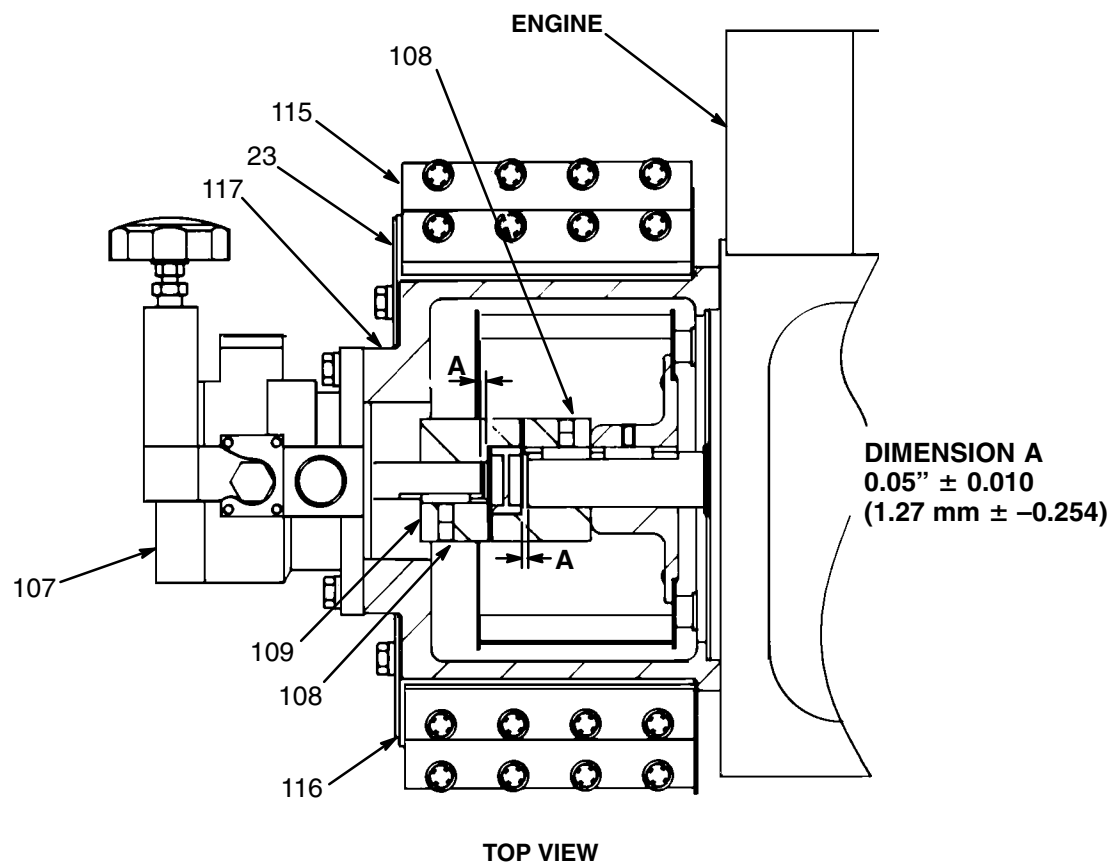

DIMENSION A
 $0.05'' \pm 0.010$
 $(1.27 \text{ mm} \pm -0.254)$

Fig 9

Displacement Pump Service

Disconnect the Displacement Pump

1. Flush the pump if possible. Stop the pump on the down stroke.
2. Follow the **Pressure Relief Procedure Warning** on page 10.
3. Remove the suction tube and fluid hose from the displacement pump.
4. Unscrew the three tie rod locknuts (48). See **GH733 Sprayer Parts Drawing**.
5. Unscrew the shouldered nut (35). Pull the displacement pump (46) off the tie rods (47).
6. Screw the jam nut (90) up onto the connecting rod (91).
7. Remove the lower cotter pin (89) and unscrew the connecting rod (91) from the displacement rod (A).
8. Refer to separate manual 309340 for displacement pump repair instructions.

Reconnecting the Displacement Pump

1. Screw the connecting rod (91) into the displacement rod (A) and replace the lower cotter pin (89). Screw the jam nut (90) all the way down. See **GH733 Sprayer Parts Drawing**.
2. Mount the displacement pump (46) onto the tie rods (47).
3. Screw the shouldered nut (35) onto the hydraulic motor (29). Screw the tie rod locknuts (48) onto the tie rods (47) and torque to 35–50 ft-lb (47–68 N.m).
4. Reattach the hoses to the displacement pump.
5. If the grounding wire was disconnected before service, be sure to reconnect it before operating the sprayer.
6. Start the pump and operate it slowly to check the tie rods for binding. Adjust the tie rod locknuts, if necessary to eliminate binding.

Complete Sprayer Parts Drawing

Model 230975, GH 733 Sprayer

Includes items 501 to 510

REF NO.	PART NO.	DESCRIPTION	QTY
501	231733	GH 733 SPRAYER (See parts list on page 19)	1
502	100380	BUSHING, pipe, 1" npt(m) to 1/2" npt(f)	1
503	158212	BUSHING, 1/2 npt(m) to 3/8 npt(f)	1
504	218659	HOSE & GUN KIT, includes items 304 to 309	1
505	215245	.HOSE, nylon, 3/8" dia. cpld 3/8 npt(mbe), 50 ft (15 m) long	1
506	156173	.ADAPTER, 3/8 npt(f) x 3/8 npsm swivel	3
507	155665	.ADAPTER, 3/8 npt(m) x 3/8 npsm swivel	2
508	150287	.ADAPTER, 1/4 npt(m) x 3/8 npt(f)	1
509	214912	.HOSE, nylon, 1/4" dia., cpld 1/4 npsm(fbe), 2'4" (0.7 m) long	1
510	235463	.AIRLESS SPRAY GUN see manual 307046 for parts	1

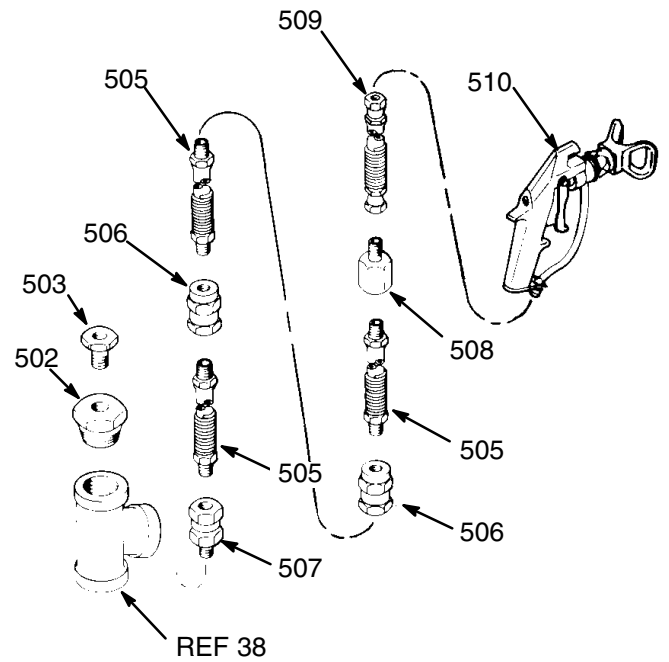

**Install this adapter in place of the fluid outlet nipple in the fluid filter.*

GH733 Sprayer Parts Drawing

Model 231733, Series D

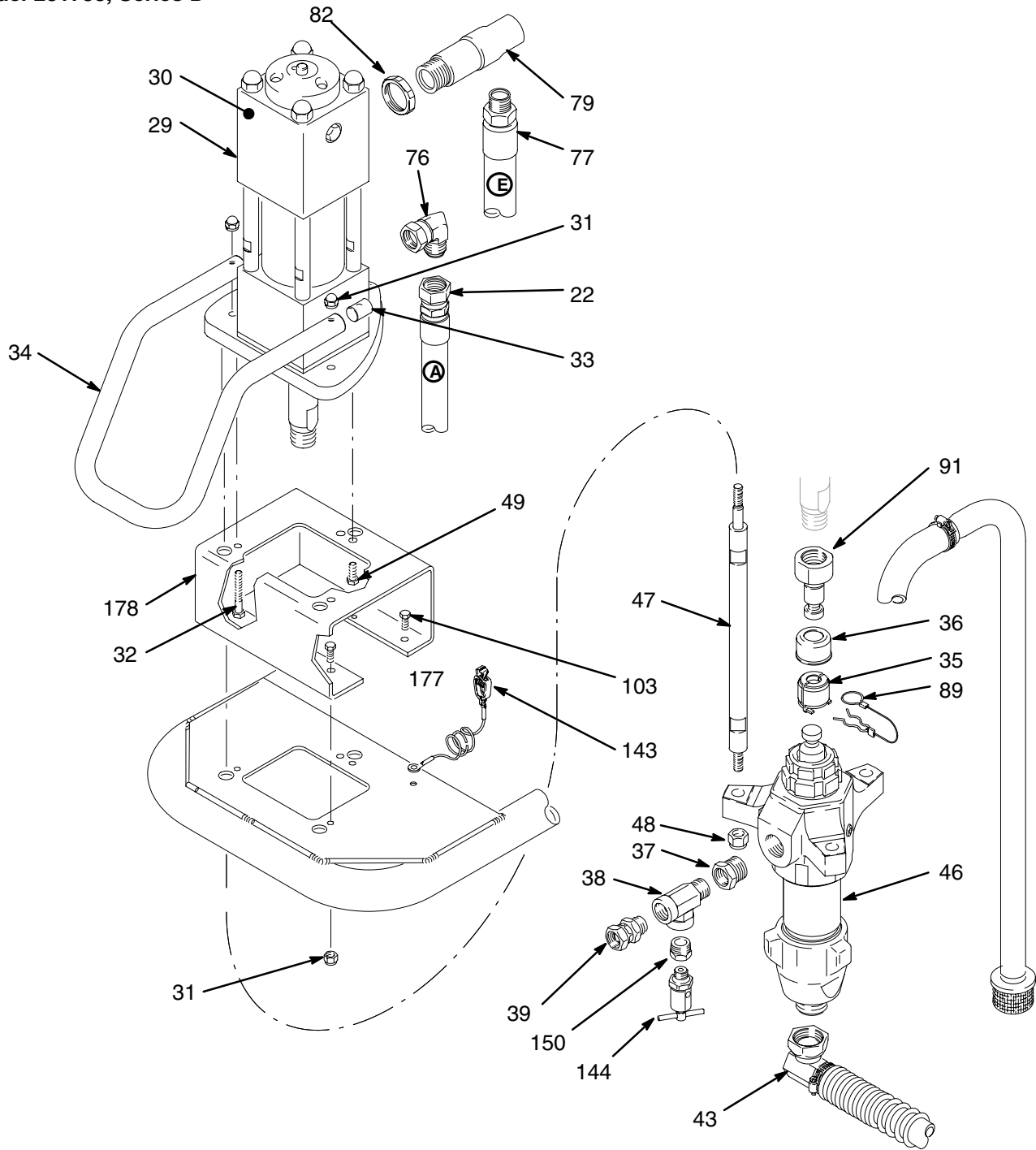

9086B

GH733 Sprayer Parts Drawing

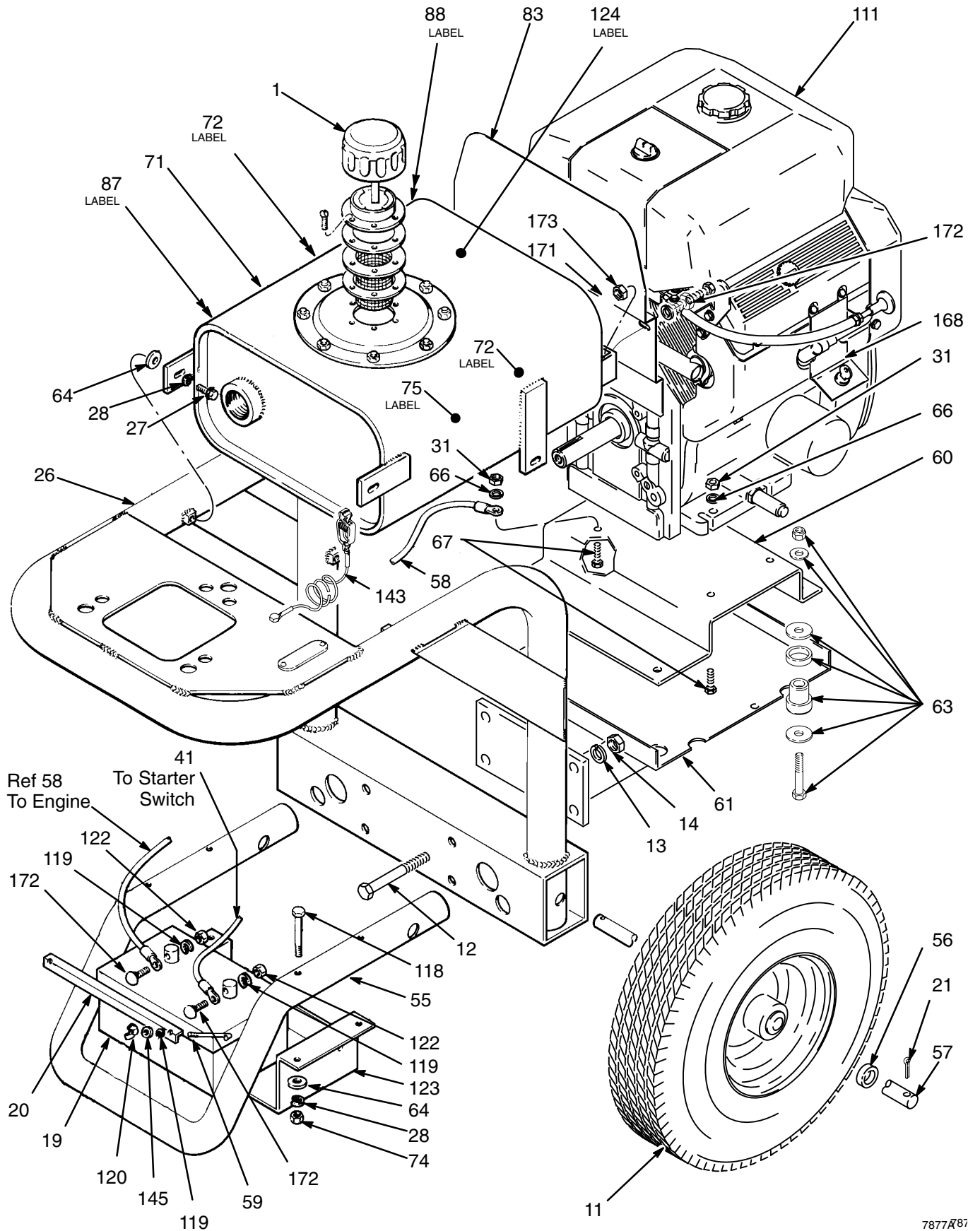

7877R87

GH733 Sprayer Parts Drawing

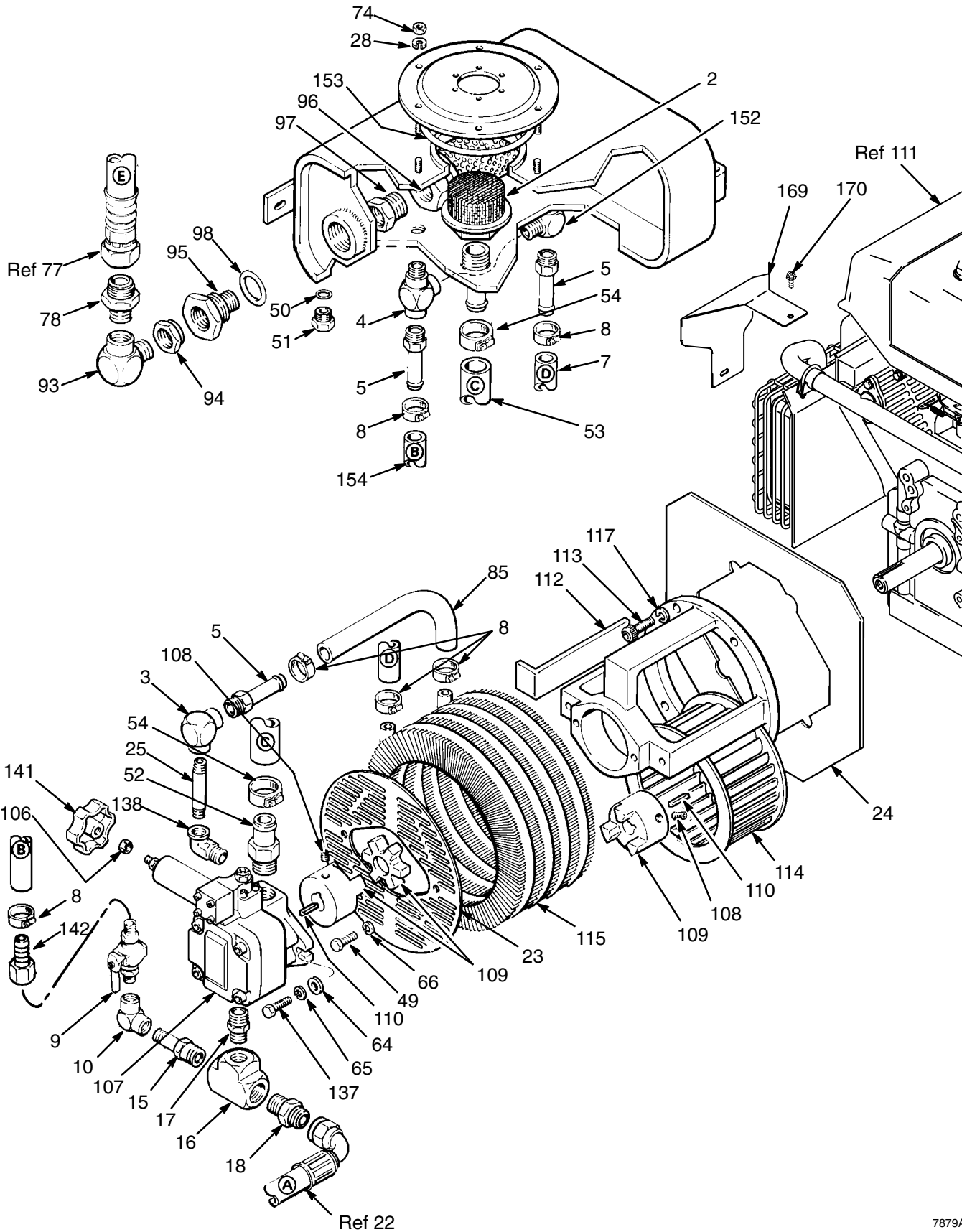

GH733 Parts List

Model 231733, Series D

Includes items 1–178

REF

NO.	PART NO.	DESCRIPTION	QTY
1	107074	BREATHER, fill cap	1
2	106114	STRAINER, inlet	1
3	107053	ELBOW, pipe, 90°, 1/2 x 3/8 npt	1
4	107128	TEE, service	1
5	107050	INSERT, hose, 1/2 npt(f)	3
7	178859	HOSE, rubber, 5" (125 mm)	1
8	102473	CLAMP, hose	6
9	210658	VALVE, ball 3/8 npt(m)	1
10	165472	ELBOW, pipe, 90°, 3/8 npt(f)	1
11	106039	WHEEL	2
12	106123	CAPSCREW, hex hd, 1/2 x 4"	4
13	100018	LOCKWASHER, spring, 1/2"	4
14	100321	NUT, hex, 1/2" thread	4
15	158979	NIPPLE, pipe, reducing, 3/8 x 1/2 npt	1
15	188344	NIPPLE, pipe, reducing, 3/8 x 1/2 npt	1
16	103475	TEE, pipe, 1/2 npt(f)	1
17	158491	NIPPLE, short, 1/2 npt	1
18	107052	FITTING, tube, flared	1
19	107126	BATTERY, 12 volt, "L" style terminals	1
20	107069	CLAMP, battery	1
21	101354	PIN, straight, spring	2
22	513575	HOSE, hydraulic supply, nylon, 3/4" ID, cpld 1–1/16" fbe, 30" (762 mm)	1
23	178751	GUARD, fan	1
24	179714	SPACER	1
25	100213	NIPPLE, pipe, 3/8 npt x 3"	1
26	217469	FRAME, pump	1
27	101578	CAPSCREW, hex head, no. 8–32 x 0.38"	4
28	100214	LOCKWASHER, spring, 5/16"	18
29	217022	MOTOR, hydraulic <i>see manual 307158 for parts</i>	1
30	177755	LABEL, identification	1
31	101566	NUT, lock, 3/8–16	6
32	106212	CAPSCREW, 3/8–16 x 2 1/2	2
33	177765	PLUG	2
34	177652	HANDLE	1
35	244819	COUPLING, assy	1
36	197340	COUPLING, cover	1
37	158586	BUSHING, 1 x 3/4"	2
38	111337	TEE, 3/4" npt(f)	1
39	157785	SWIVEL, 3/4" m x f	1
41	113952	CABLE, battery, positive, 26", 6 awg	1
43	243987	TUBE, suction, inlet	1
46	244416	PUMP, displacement <i>see manual 309340 for parts</i>	1
47	198592	ROD, tie, 14.59" (371 mm)	3
48	101712	NUT, lock, type "E" 5/8"– 11	3
49	100101	CAPSCREW, hex head, 3/8–16 x 1"	5
50	104444	O–RING, VITON®	1
51	104126	PLUG, box, 3/4"	1
52	107049	INSERT, hose, 3/4 npt(f)	1
53	178791	HOSE, suction, 1" ID, 3' (9.9 m)	1
54	101818	CLAMP, hose, for 13/16" to 1–1/2" OD	2
55	178773	LEG, frame	1
56	177641	WASHER, flat	2
57	177570	AXLE	1
58	113951	CABLE, battery, negative, 13", 6 awg	1
59	107068	HOOK, bolt, 1/4" thread	1
60	191955	PLATE, engine	1
61	216141	SUPPORT, engine	1
63	246015	MOUNT, motor	1
64	100023	WASHER, 3/8"	14
66	100133	LOCKWASHER, 3/8"	8
67	102547	CAPSCREW, hex hd, 3/8 x 2.5"	4
71	218125	RESERVOIR KIT	1
72	185951*	LABEL, DANGER	1
74	100188	NUT, heavy hex, 5/16–18 unc–2a	10
75	177807	LABEL, identification	1
76	106053	ELBOW, 90°, 1–1/16" thread	1
77	513574	HOSE, hyd rtn, 1" x 20.75"	1
78	107127	ADAPTER, male, 1–5/16" x 3/4"	1
79	620188	ADAPTER, 1" (m) x 3/4 x 1/2 x 3/8 (f)	1
82	105430	NUT, seal, 1" npt	1
83	191957	SHIELD, heat	1
85	178795	HOSE, cooler, 0.625", 10.5" lg	1
87	177808	LABEL, identification	1
88	178935	LABEL, caution	1
89	244820	CLIP, hairpin, with lanyard	1
91	197341	ROD, adapter	1
93	107125	ELBOW, 90° street, 3/4 npt(m)	1
94	105429	NUT, seal, 3/4 npt	1
95	178750	FITTING, return, 1" npt(m) x 3/4 npt(f)	1
96	178794	FILTER, fluid	1
97	500054	BUSHING, hex hd	1
98	107067	O–RING, buna–n	1
103	112798	SCREW, mach, hex washer hd, 8 x 3/8"	1
105	219099	KNOB, pump	1
106	100187	NUT, hex, 5/16"	1
107	178872	PUMP, vane, hydraulic	1
108	100421	SETSCREW, 5/16" X 3/8"	2
109	106063	COUPLER	2
110	605358	KEY, 1/4"	2
111	113822	ENGINE, 16 HP, OHC	1
112	107143	CAPSCREW, sch, 7/16 x 1.25"	4
113	100052	LOCKWASHER, spring, 7/16"	4
114	178792	BLOWER	1
115	178788	COOLER	1
116	178861	PAD	2
117	178786	SUPPORT, pump	1
118	102169	CAPSCREW, hex hd, 5/16 x 1.5	4
119	100016	LOCKWASHER, spring, 1/4"	4
120	100011	WING NUT, 1/2"	2
122	100015	NUT, hex, 1/4–10 unc	2
123	178787	SHELF, battery	1
130	106229	NIPPLE	1
131	206994	TSL, 8 oz. <i>not shown</i>	1
132	185016	LABEL, Caution	1
137	100004	CAPSCREW, hex hd, 3/8–16" x 1.25"	2
138	107032	ELBOW, 90° street, 3/8 npt (m x f)	1
139	158683	ELBOW, 90°, 3/8 npt(mxf)	1
140	108426	O–RING, buna–n	1
141	183574	HOSE, rubber tube, 4.5"	1
142	183575	NIPPLE, barbed hose, 3/8–18 npt(f)	1
143	237686	GROUND WIRE & CLAMP	1
144	244683	VALVE, pressure drain	1
145	158233	WASHER, flat	2
150	100896	BUSHING, 3/4 x 3/8"	1
167	110838	LOCKNUT, 5/16"	4
168	191958	BRACKET, switch	1
169	191959	GUARD, muffler	1
170	112179	SCREW, thread forming, (M5 x .8 mm)	1
171	113819	NUT, 1/4"	2
172	100022	SCREW, cap, 1/4"	4
173	100016	WASHER, lock	2
174	290320	LABEL, identification	1
175	290319	LABEL, caution	1
176	070401	TUBING, electrical, 13"	1
177	100101	SCREW, cap, hex hd, 1 x 3/8–16" unc–2a	4
178	625057	BRACKET, motor, hydraulic	1

*DANGER and WARNING labels are available at no charge.

Technical Data

Engine	KOHLER Model TH16 OHC 4 cycle twin cylinder, air cooled, 16 HP, (12 Kw)
Gasoline	1.7 gallon (6.4 liter capacity) consumes 1.3 gal/hr (4.9 liter/hr)
Hydraulic Fluid Sump	5 gallon (19 liters)
Hydraulic Pressure	1300 psi (89 bar) 10.2 gpm (39 l/min)
Displacement Pump	3500 psi (240 bar, 24 MPa) Maximum Working Pressure 3 gpm (11.4 lpm) output, 15 cycles/gallon
Pump Fluid Outlet Size	1 in. npt(f)
Fluid Filter Outlet Size	1/4 npt(f)
Wetted Parts:	
Displacement Pump	Steel, Nitralloy, Tungsten CarbidePTFE®, Leather
Filter	Aluminum, Carbon steel, Stainless Steel,
Weight (dry w/o packaging)	465 lb (103 kg)
Height	50.5 in. (1.3 m)
Length	48 in. (1.2 m)
Width	29 in. (736 mm)
Sound Levels*:	
Sound Pressure	91 dB(A)
Sound Power	106 dB(A)

* Measured at maximum normal load conditions.

NOTE: PTFE®

Graco Phone Number

TO PLACE AN ORDER, contact your Graco distributor, or call this number to identify the distributor closest to you: **1-800-690-2894 Toll Free.**

Accessories

Must be purchased separately.

GRACO-APPROVED HYDRAULIC OIL

169236	5 Gallons (20 liters)
207428	1 Gallon (3.8 liters)

DANGER LABELS

The English language DANGER label shown on page 4 is also on your sprayer. If you have painters who do not read English, order one of the following labels to apply to your sprayer. The drawing below shows the best placement of these labels for good visibility.

Order the labels directly from Graco, free of charge. Toll Free: 1-800-328-0211

French	186956
Spanish	185961
German	186041
Greek	186045
Korean	186049
English	185593

Apply other language here

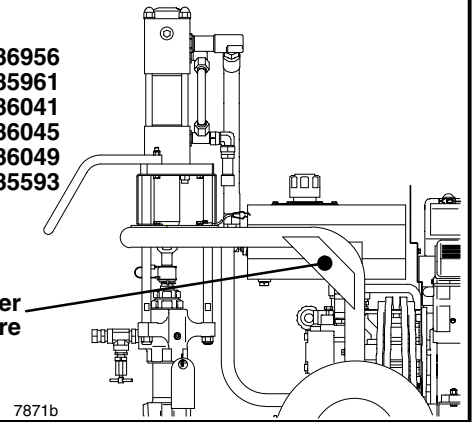

Graco Warranty

Graco warrants all equipment listed in this manual which is manufactured by Graco and bearing its name to be free from defects in material and workmanship on the date of sale by an authorized Graco distributor to the original purchaser for use. With the exception of any special extended or limited warranty published by Graco, Graco will, for a period of twelve months from the date of sale, repair or replace any part of the equipment determined by Graco to be defective. This warranty applies only when the equipment is installed, operated and maintained in accordance with Graco's written recommendations.

This warranty does not cover, and Graco shall not be liable for general wear and tear, or any malfunction, damage or wear caused by faulty installation, misapplication, abrasion, corrosion, inadequate or improper maintenance, negligence, accident, tampering, or substitution of non-Graco component parts. Nor shall Graco be liable for malfunction, damage or wear caused by the incompatibility of Graco equipment with structures, accessories, equipment or materials not supplied by Graco, or the improper design, manufacture, installation, operation or maintenance of structures, accessories, equipment or materials not supplied by Graco.

This warranty is conditioned upon the prepaid return of the equipment claimed to be defective to an authorized Graco distributor for verification of the claimed defect. If the claimed defect is verified, Graco will repair or replace free of charge any defective parts. The equipment will be returned to the original purchaser transportation prepaid. If inspection of the equipment does not disclose any defect in material or workmanship, repairs will be made at a reasonable charge, which charges may include the costs of parts, labor, and transportation.

Graco's sole obligation and buyer's sole remedy for any breach of warranty shall be as set forth above. The buyer agrees that no other remedy (including, but not limited to, incidental or consequential damages for lost profits, lost sales, injury to person or property, or any other incidental or consequential loss) shall be available. Any action for breach of warranty must be brought within two (2) years of the date of sale.

GRACO MAKES NO WARRANTY, AND DISCLAIMS ALL IMPLIED WARRANTIES OF MERCHANTABILITY AND FITNESS FOR A PARTICULAR PURPOSE IN CONNECTION WITH ACCESSORIES, EQUIPMENT, MATERIALS OR COMPONENTS SOLD BUT NOT MANUFACTURED BY GRACO. These items sold, but not manufactured by Graco (such as electric motors, gas engines, switches, hose, etc.), are subject to the warranty, if any, of their manufacturer. Graco will provide purchaser with reasonable assistance in making any claim for breach of these warranties.

In no event will Graco be liable for indirect, incidental, special or consequential damages resulting from Graco supplying equipment hereunder, or the furnishing, performance, or use of any products or other goods sold hereto, whether due to a breach of contract, breach of warranty, the negligence of Graco, or otherwise.

FOR GRACO CANADA CUSTOMERS

The parties acknowledge that they have required that the present document, as well as all documents, notices and legal proceedings entered into, given or instituted pursuant hereto or relating directly or indirectly hereto, be drawn up in English. Les parties reconnaissent avoir convenu que la rédaction du présente document sera en Anglais, ainsi que tous documents, avis et procédures judiciaires exécutés, donnés ou intentés à la suite de ou en rapport, directement ou indirectement, avec les procédures concernées.

ADDITIONAL WARRANTY COVERAGE

Graco does provide extended warranty and wear warranty for products described in the "Graco Contractor Equipment Warranty Program".

All written and visual data contained in this document reflect the latest product information available at the time of publication. Graco reserves the right to make changes at any time without notice.

Sales Offices: Minneapolis, Detroit
International Offices: Belgium, Korea, Hong Kong, Japan

GRACO INC. P.O. BOX 1441 MINNEAPOLIS, MN 55440-1441
<http://www.graco.com>

PRINTED IN U.S.A. 307616 September 1983, Revised 5/2002