



 INSTRUCTIONS	<p>This manual contains important warnings and information. READ AND RETAIN FOR REFERENCE</p>
-------------------------	--

Displacement Pump

FOR BULLDOG® , KING™ , SENATOR® AND VISCOUNT® PUMPS, AND GH 733 SPRAYER

4500 psi (315 bar) Maximum Working Pressure

Part No. 217-527, Series E

Severe-Duty Pump*, with UHMWPE and leather packings

Part No. 237-406, Series A

Severe-Duty Pump*, with PTFE packings

Part No. 224-435, Series B

Severe-Duty Pump*, with leather packings

Part No. 223-584, Series C

Severe-Duty Pump*, with leather packings and Stainless Steel Glands, Intake Housing, Piston Valve and Ball Stop

* Severe-Duty Displacement Pumps have an abrasion and corrosion-resistant displacement rod and cylinder. Refer to **Technical Data** on the back cover for Wetted Parts information.

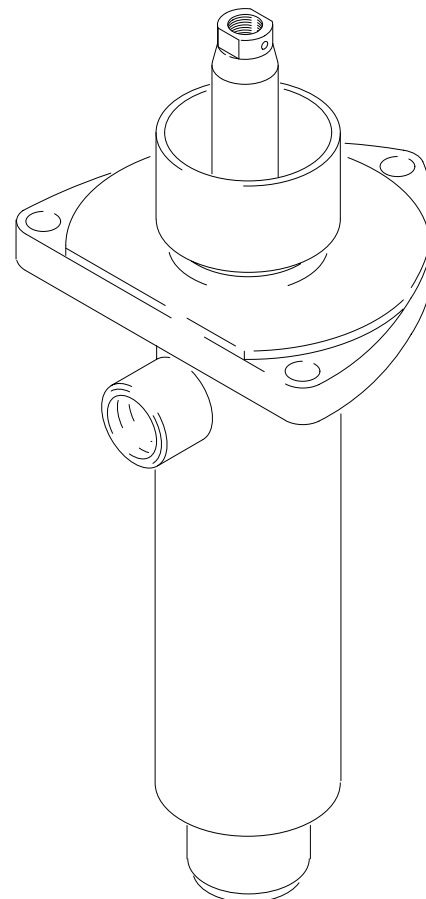

Model 217-527 Shown

Table of Contents

Warnings	2-4
Service/Parts List	
Models 217-527 and 237-406	5-7
Models 224-435 and 223-584	8-11
Accessories	11
Technical Data	Back Cover
Warranty	Back Cover
Graco Phone Numbers	Back Cover

02520

WARNINGS

High Pressure Spray Can Cause Serious Injury. For Professional Use Only.
Observe All Warnings. Read and understand all instruction manuals before operating equipment.

FLUID INJECTION HAZARD

General Safety

This equipment generates very high fluid pressure. Spray from the gun/dispensing valve, leaks or ruptured components can inject fluid through your skin and into your body and cause extremely serious bodily injury, including the need for amputation. Also, fluid injected or splashed into the eyes or on the skin can cause serious damage.

Never point the spray gun/dispensing valve at anyone or at any part of the body. Never put hand or fingers over the spray tip/nozzle. Never try to “blow back” paint; this is **not** an air spray system.

Always have the tip guard in place on the spray gun when spraying.

Always follow the **Pressure Relief Procedure**, right, before cleaning or removing the spray tip/nozzle or servicing any system equipment.

Never try to stop or deflect leaks with your hand or body.

Be sure equipment safety devices are operating properly before each use.

Medical Alert – Airless Spray Wounds

If any fluid appears to penetrate your skin, get **emergency medical care at once. Do not treat as a simple cut.** Tell the doctor exactly what fluid was injected.

NOTE TO PHYSICIAN: Injection into the skin is a traumatic injury. **It is important to treat the injury surgically as soon as possible.** Do not delay treatment to research toxicity. Toxicity is a concern with some exotic coatings injected directly into the blood stream. Consultation with a plastic surgeon or reconstructive hand surgeon may be advisable.

Spray Gun/Dispensing Valve Safety Devices

Be sure all spray gun/dispensing valve safety devices are operating properly before each use. Do not remove or modify any part of the spray gun/dispensing valve; this can cause a malfunction and result in serious bodily injury.

Safety Latch

Whenever you stop spraying/dispensing, even for a moment, always set the safety latch in the closed or “safe” position, making the spray gun/dispensing valve inoperative. Failure to set the safety latch can result in accidental triggering of the spray gun/dispensing valve.

Trigger Guard (if so equipped)

Never operate the spray gun/dispensing valve with the trigger guard removed. This guard helps prevent the gun/dispensing valve from triggering accidentally if it is dropped or bumped.

Diffuser (only on spray guns)

The spray gun diffuser breaks up spray and reduces the risk of fluid injection when the tip is not installed. Check the diffuser operation regularly. Follow the **Pressure Relief Procedure**, below, then remove the spray tip. Aim the spray gun into a grounded metal pail, holding the spray gun firmly to the pail. Using the lowest possible pressure, trigger the spray gun. If the fluid emitted is not diffused into an irregular stream, replace the diffuser immediately.

Tip Guard (only on spray guns)

Always have the tip guard in place on the spray gun while spraying. The tip guard alerts you to the fluid injection hazard and helps reduce, **but does not prevent**, the risk of accidentally placing your fingers or any part of your body close to the spray tip.

Spray Tip/Nozzle Safety

Use extreme caution when cleaning or changing spray tips/nozzles. If the spray tip/nozzle clogs while spraying/dispensing, engage the safety latch immediately. Always follow the **Pressure Relief Procedure** and then remove the spray tip/nozzle to clean it.

Never wipe off build-up around the spray tip/nozzle until pressure is fully relieved and the safety latch is engaged.

Pressure Relief Procedure

To reduce the risk of serious bodily injury, including fluid injection, splashing in the eyes or on the skin, or injury from moving parts, always follow this procedure whenever you shut off the pump, when checking or servicing any part of the spray/dispensing system, when installing, cleaning or changing spray tips/nozzles, and whenever you stop spraying/dispensing.

1. Engage the spray gun/dispensing valve safety latch.
2. Shut off the air or hydraulic fluid to the pump.
3. Close the bleed-type master air valve (required in air-powered systems).
4. Disengage the spray gun/dispensing valve safety latch.
5. Hold a metal part of the spray gun/dispensing valve firmly to the side of a grounded metal pail, and trigger the gun/dispensing valve to relieve pressure.
6. Engage the spray gun/dispensing valve safety latch.
7. Open the drain valve (required in your system), having a container ready to catch the drainage.
8. Leave the drain valve open until you are ready to spray again.

If you suspect that the spray tip/nozzle or hose is completely clogged, or that pressure has not been fully relieved after following the steps above, **very slowly** loosen the retaining nut or hose end coupling and relieve pressure gradually, then loosen completely. Now clear the tip/nozzle or hose.

EQUIPMENT MISUSE HAZARD

General Safety

Any misuse of the spray/dispensing equipment or accessories, such as overpressurizing, modifying parts, using incompatible chemicals and fluids, or using worn or damaged parts, can cause them to rupture and result in fluid injection, splashing in the eyes or on the skin, or other serious bodily injury, or fire, explosion or property damage.

Never alter or modify any part of this equipment; doing so could cause it to malfunction.

Check all spray/dispensing equipment regularly and repair or replace worn or damaged parts immediately.

Always wear protective eyewear, gloves, clothing and respirator as recommended by the fluid and solvent manufacturer.

System Pressure

The maximum safe working pressure is determined by the air or hydraulic motor. Do not exceed the maximum working pressure stated on your complete pump.

Be sure that all spray equipment and accessories are rated to withstand the maximum working pressure of the pump. Do not exceed the maximum working pressure of any component or accessory used in the system.

Fluid Compatibility

Be sure that all fluids and solvents used are chemically compatible with the wetted parts shown in the **Technical Data** on the back cover. Always read the manufacturer's literature before using fluid or solvent in this pump.

FIRE OR EXPLOSION HAZARD

Static electricity is created by the high velocity flow of fluid through the pump and hose. If every part of the spray/dispensing equipment is not properly grounded, sparking may occur, and the system may become hazardous. Sparking may also occur when plugging in or unplugging a power supply cord. Sparks can ignite fumes from solvents and the fluid being sprayed/dispensed, dust particles and other flammable substances, whether you are spraying/dispensing indoors or outdoors, and can cause a fire or explosion and serious bodily injury and property damage. Do not plug in or unplug any power supply cords in the spray/dispensing area when there is any chance of igniting fumes still in the air.

If you experience any static sparking or even a slight shock while using this equipment, **stop spraying/dispensing immediately**. Check the entire system for proper grounding. Do not use the system again until the problem has been identified and corrected.

Grounding

To reduce the risk of static sparking, ground the pump and all other spray/dispensing equipment used or located in the spray/dispensing area. Check your local electrical code for detailed grounding instructions for your area and type of equipment. Be sure to ground all of this spray/dispensing equipment:

1. *Pump*: Ground the complete pump as indicated in your separate pump instruction manual.
2. *Air or hydraulic hoses*: use only grounded hoses.
3. *Fluid hoses*: use only grounded fluid hoses.
4. *Air compressor or hydraulic supply*: follow manufacturer's recommendations.
5. *Spray gun/dispensing valve*: grounding is obtained through connection to a properly grounded fluid hose and pump.

6. *Fluid supply container*: according to your local code.

7. *Object being sprayed*: according to your local code.

8. *All solvent pails used when flushing*, according to your local code. Use only metal pails, which are conductive, placed on a grounded surface. Do not place the pail on a nonconductive surface, such as paper or cardboard, which interrupts the grounding continuity.

9. *To maintain grounding continuity when flushing or relieving pressure*, always hold a metal part of the spray gun/dispensing valve firmly to the side of a grounded *metal* pail, then trigger the spray gun/dispensing valve.

Flushing Safety

Before flushing, be sure the entire system and flushing pails are properly grounded. Refer to **Grounding**, at the left. Follow the **Pressure Relief Procedure** on page 2, and remove the spray tip/nozzle from the spray gun/dispensing valve. Always use the lowest possible fluid pressure, and maintain firm metal-to-metal contact between the spray gun/dispensing valve and the pail during flushing to reduce the risk of fluid injection injury, static sparking and splashing.

MOVING PARTS HAZARD

Moving parts can pinch or amputate your fingers or other body parts. In air-powered systems, the air motor piston (located behind the air motor shield) moves when air is supplied to the motor. Therefore, never operate the pump with the air motor shield removed. Keep clear of moving parts when starting or operating the pump. Before checking or servicing the pump, follow the **Pressure Relief Procedure** on page 2 to prevent the pump from starting accidentally.

HOSE SAFETY

High pressure fluid in the hoses can be very dangerous. If the hose develops a leak, split or rupture due to any kind of wear, damage or misuse, the high pressure spray emitted from it can cause a fluid injection injury or other serious bodily injury or property damage.

All fluid hoses must have spring guards on both ends!

The spring guards help protect the hose from kinks or bends at or close to the coupling which can result in hose rupture.

Tighten all fluid connections securely before each use. High pressure fluid can dislodge a loose coupling or allow high pressure spray to be emitted from the coupling.

Never use a damaged hose. Before each use, check the entire hose for cuts, leaks, abrasion, bulging cover, or damage or movement of the hose couplings. If any of these conditions exist, replace the hose immediately. Do not try to recouple high pressure hose or mend it with tape or any other device. A repaired hose cannot safely contain the high pressure fluid.

Handle and route hoses carefully. Do not pull on hoses to move equipment. Do not use fluids which are not compatible with the inner tube and cover of the hose. Do not expose Graco hoses to temperatures above 180° F (82° C) or below -40° F (-40° C).

Hose Grounding Continuity

Proper hose grounding continuity is essential to maintaining a grounded spray/dispensing system. Check the electrical resistance of your air and fluid hoses at least once a week. If your hose does not have a tag on it which specifies the maximum electrical resistance, contact the hose supplier or manufacturer for the maximum resistance limits. Use a resistance meter in the appropriate range for your hose to check the resistance. If the resistance exceeds the recommended limits, replace it immediately. An ungrounded or poorly grounded hose can make your system hazardous. Also, read **FIRE OR EXPLOSION HAZARD**, on page 3.

IMPORTANT

United States Government safety standards have been adopted under the Occupational Safety and Health Act. These standards – particularly the General Standards, Part 1910, and the Construction Standards, Part 1926 – should be consulted.

Service

MODELS 217-527 & 237-406

Disassembly

NOTE: Packing Repair Kit 220-395 is available for Model 217-527. See the parts list on page 7. For the best results, use all the new parts in the kit, even if the old ones look good. An asterisk behind a reference number, for example (9*), indicates that this part is included in the repair kit. For Model 237-406, keep the parts marked with a check (9✓) on hand to reduce downtime. Refer to the parts list on page 7.

1. Solvent flush the pump, if possible. Follow the **Pressure Relief Procedure** on page 2, then disconnect all hoses from the pump.
2. Loosen the packing nut (2). Disconnect the displacement pump from the motor (see your separate pump manual).
3. Screw the intake valve housing (4) out of the pump housing (1). See Fig. 1. Note which set of holes the ball stop pin (11) is in, then disassemble and clean the parts of the valve.
4. Push down on the displacement rod (22) until the piston (3) flats clear the pump housing (1). Pull the piston and displacement rod assembly straight out of the pump housing, being careful not to damage the rod or housing.
5. Unscrew the piston, and remove the ball, washer, v-packings and glands.
6. Remove the packing nut/wet-cup (2). Remove the v-packings and glands from the pump throat.
7. Clean all parts thoroughly, and check for wear, scratches or other damage. Be sure the ball seats of the piston (3) and intake valve housing (4) are not chipped or nicked. Replace any worn or damaged parts to ensure that the pump will not leak. Scoring or irregular surfaces on the displacement rod (22) or polished inner wall of the sleeve (14) can cause premature packing wear and leaking. Check these parts by rubbing a finger on the surfaces or by holding the parts up to the light at an angle. If either is worn or scratched, replace it.

NOTE: If replacing the sleeve, be sure to install it with the tapered end down toward the pump inlet, and also replace the gasket (15*). If the sleeve is hard to remove, contact Graco Technical Assistance (see back page).

- ① See detail in Fig. 2.
- ② See detail in Fig. 3.
- ③ Apply thread sealant and torque to 150-175 ft-lb (203-237 N.m).
- ④ Torque to 80-100 ft-lb (108-136 N.m).

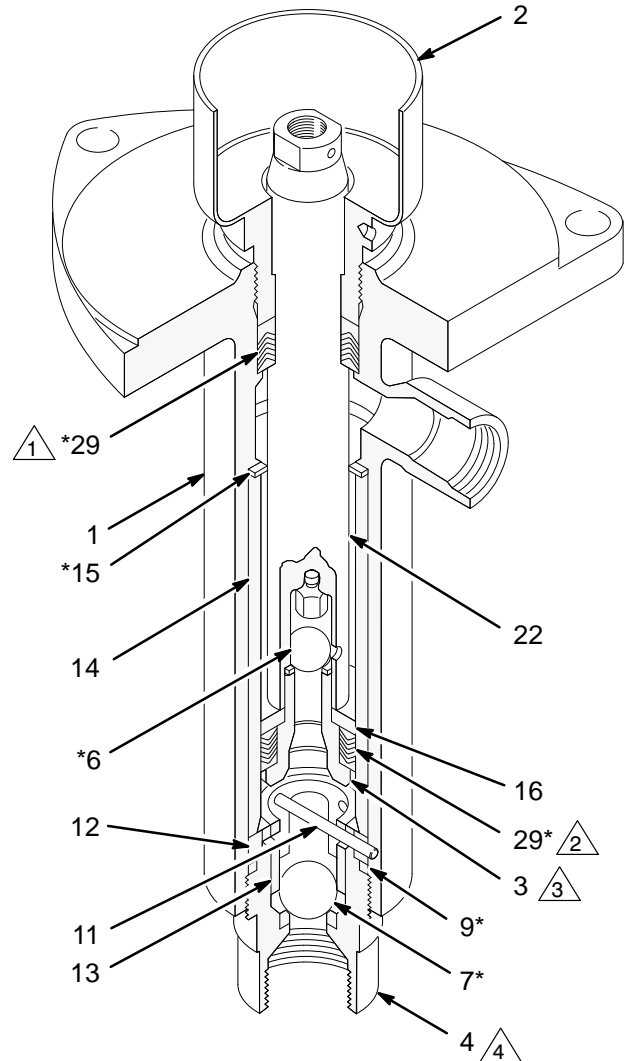

02525

Fig. 1

Service

MODELS 217–527 & 237–406

Reassembly

1. Lubricate the packings with a lightweight grease for easier assembly.
2. Remove the shims from one of the packing stacks (29*) and install the stack in the throat of the pump housing. *Be sure the lips of the v-packings face down in the throat.* See Fig. 2.
3. Loosely install the packing nut/wet-cup (2).
4. Install the other packing stack (29*) on the piston (3). **Do not** disassemble the stack. *Be sure the lips of the v-packings face up on the piston.* See Fig. 3.
5. Place the washer (16) and ball (6*) on the piston, apply thread sealant to the piston threads, and screw the piston assembly into the displacement rod (22). Torque to 150–175 ft-lb (203–237 N.m). See Fig. 1.
6. Lubricate the displacement rod (22). Carefully guide the rod into the bottom of the pump housing (1), and push it up through the throat packings.
7. Install the o-ring (9*) and retainer (12) on the intake valve housing (4). Install the ball (7*), ball guide (13), and ball stop pin (11) in the intake valve housing. *Be sure the pin (11) is in the desired set of holes. Refer to **Check Valve Adjustment**.* Screw the assembly into the pump housing (1). Torque to 80–100 ft-lb (108–136 N.m).
8. Reconnect the displacement pump to the motor (see your separate pump manual). Reconnect the ground wire if it was disconnected during repair.
9. Follow the **Pressure Relief Procedure** on page 2. Tighten the throat packing nut (2) just enough to prevent leakage, but no tighter. Use the wrench supplied with the complete pump. Fill the wet-cup half full with TSL or compatible solvent.

Check Valve Adjustment

The intake check valve is set for high flow rates or high viscosity fluids. To set the valve for lighter viscosity fluids or a lower flow rate, to minimize surging at pump stroke changeover, move the ball stop pin (11) to the lower set of holes, decreasing the check ball travel. To adjust the piston check valve for use with very light viscosity fluids, refer to **Accessories** on page 11.

Detail of Throat Gland/Packing Stack

- 1 Lips of v-packings must face down.
- 2 Remove shims from packing stack before installing in throat.

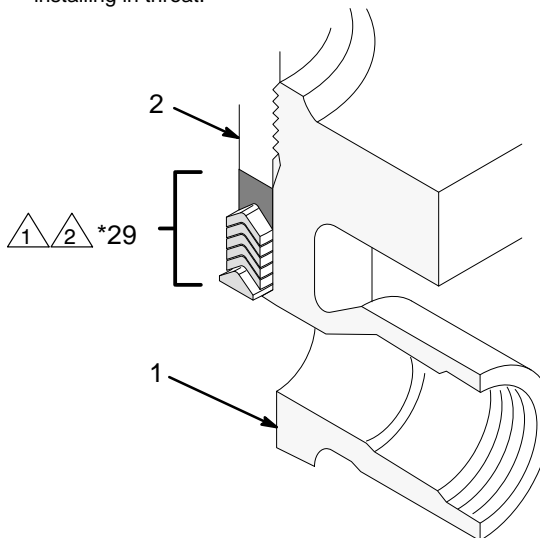

Fig. 2

02523

Detail of Piston Gland/Packing Stack

- 1 Lips of v-packings must face up.
- 2 Do not disassemble stack when installing on piston.

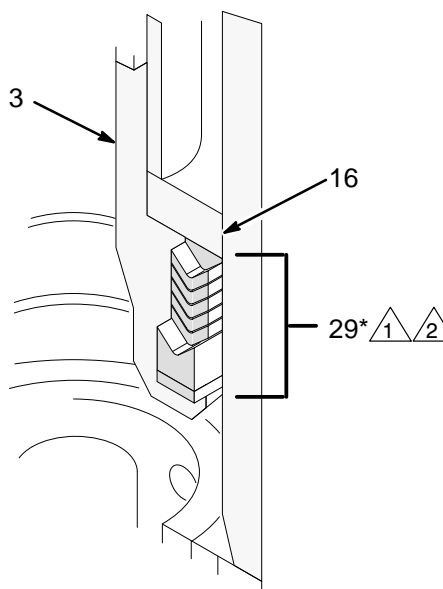

Fig. 3

02523

Parts

Model 217-527, Series E

Ref No.	Part No.	Description	Qty
1	207-470	HOUSING, pump; carbon steel	1
2	207-471	PACKING NUT/WET-CUP; carbon steel	1
3✓	207-472	PISTON; carbon steel with tungsten carbide seat	1
4	207-473	HOUSING, intake valve; carbon steel with tungsten carbide seat	1
6*	102-972	BALL, stainless steel; 7/8" dia.	1
7*	102-973	BALL, stainless steel; 1-1/4" dia	1
9*	106-260	O-RING; PTFE	1
11	167-890	PIN, ball stop, intake valve; carbon steel	1
12	167-891	RETAINER; carbon steel	1
13	167-892	GUIDE, ball; carbon steel	1
14	178-894	SLEEVE; stainless steel	1
15*	167-894	GASKET; PTFE	1
16✓	167-895	WASHER, flat; carbon steel	1
22	178-888	ROD, displacement; stainless steel	1
26▲	172-479	TAG, warning (not shown)	1
29*	223-365	GLAND/PACKING STACK; UHMWPE/leather	2

* These parts are included in Repair Kit 220-395, which may be purchased separately. The kit includes a tube of 102-969 thread sealant for use on the piston (3).

✓ Keep these spare parts on hand to reduce down time.

▲ Replacement Danger and Warning labels, tags and cards are available at no cost.

Model 237-406, Series A

Ref No.	Part No.	Description	Qty
1	207-470	HOUSING, pump; carbon steel	1
2	207-471	PACKING NUT/WET-CUP; carbon steel	1
3✓	207-472	PISTON; carbon steel with tungsten carbide seat	1
4	207-473	HOUSING, intake valve; carbon steel with tungsten carbide seat	1
6✓	102-972	BALL, stainless steel; 7/8" dia.	1
7✓	102-973	BALL, stainless steel; 1-1/4" dia	1
9✓	106-260	O-RING; PTFE	1
11	167-890	PIN, ball stop, intake valve; carbon steel	1
12	167-891	RETAINER; carbon steel	1
13	167-892	GUIDE, ball; carbon steel	1
14	178-894	SLEEVE; stainless steel	1
15✓	167-894	GASKET; PTFE	1
16✓	167-895	WASHER, flat; carbon steel	1
22	178-888	ROD, displacement; stainless steel	1
26▲	172-479	TAG, warning (not shown)	1
29✓	223-479	GLAND/PACKING STACK; PTFE	2

✓ Keep these spare parts on hand to reduce down time.

▲ Replacement Danger and Warning labels, tags and cards are available at no cost.

- 1 Lips of v-packings must face down.
- 2 Remove shims from packing stack before installing in throat.
- 3 Lips of v-packings must face up.
- 4 Do not disassemble stack when installing on piston.
- 5 Male Gland
- 6 Female Gland
- 7 UHMWPE V-Packing (Model 217-527)
- 8 Leather V-Packing (Model 217-527)
- 9 Shim
- 10 PTFE V-Packing (Model 237-406)

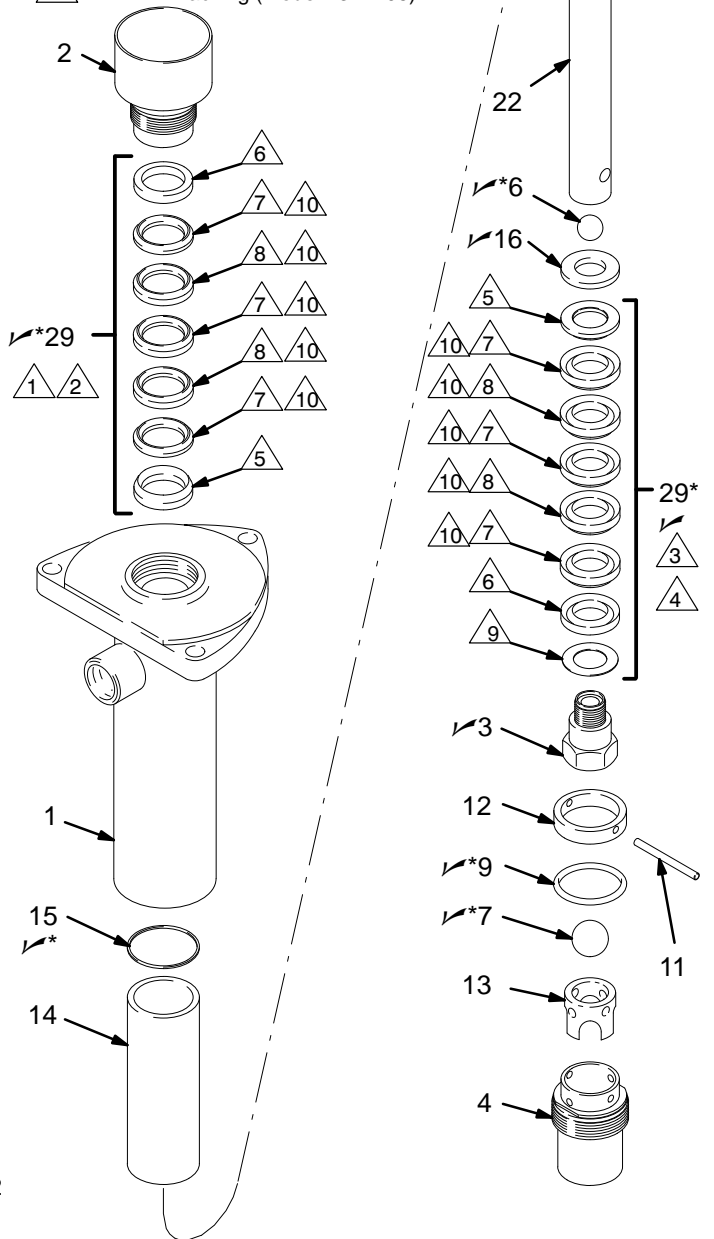

02521

Service

MODELS 224-435 & 223-584

Disassembly

NOTES: Packing Repair Kits are available. See the parts list for your pump on pages 10 and 11. For the best results, use all the new parts in the kit, even if the old ones look good. An asterisk behind a reference number, for example (9*), indicates that this part is included in the repair kit.

1. Solvent flush the pump, if possible. Follow the **Pressure Relief Procedure** on page 2, then disconnect all hoses from the pump.
2. Loosen the packing nut (2). Disconnect the displacement pump from the motor (see your separate pump manual).
3. Screw the intake valve housing (4) out of the pump housing (1). See Fig. 4. Note which set of holes the ball stop pin (11) is in, then disassemble and clean the parts of the valve.
4. Push down on the displacement rod (22) until the piston (3) flats clear the pump housing (1). Pull the piston and displacement rod assembly straight out of the pump housing, being careful not to damage the rod or housing.
5. Unscrew the piston, and remove the ball, washer, v-packings and glands.
6. Remove the packing nut/wet-cup (2). Remove the v-packings and glands from the pump throat.
7. Clean all parts thoroughly, and check for wear, scratches or other damage. Be sure the ball seats of the piston (3) and intake valve housing (4) are not chipped or nicked. Replace any worn or damaged parts to ensure that the pump will not leak. Scoring or irregular surfaces on the displacement rod (22) or polished inner wall of the sleeve (14) can cause premature packing wear and leaking. Check these parts by rubbing a finger on the surfaces or by holding the parts up to the light at an angle. If either is worn or scratched, replace it.

NOTE: If replacing the sleeve, be sure to install it with the tapered end down toward the pump inlet, and also replace the gasket (15*). If the sleeve is hard to remove, contact Graco Technical Assistance (see back page).

- △1 See detail in Fig. 5.
- △2 See detail in Fig. 6.
- △3 Apply thread sealant (Model 224-435 only).
- △4 Torque to 150-175 ft-lb (203-237 N.m).

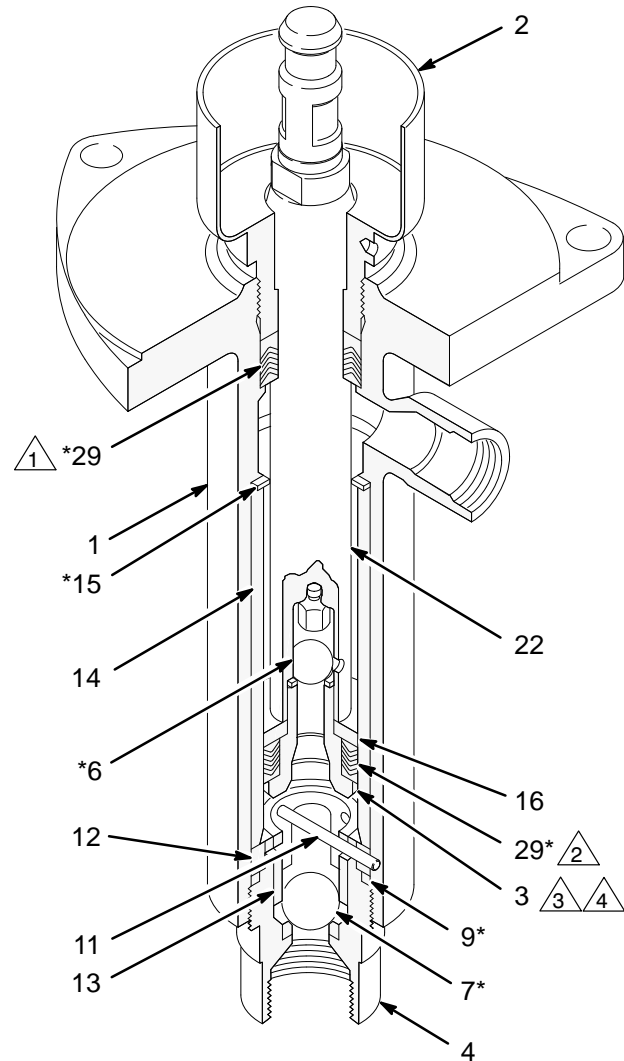

02524

Fig. 4

Service

MODELS 224–435 & 223–584

Reassembly

1. Lubricate the packings with a lightweight grease for easier assembly.
2. Remove the shims from one of the packing stacks (29*) and install the stack in the throat of the pump housing. *Be sure the lips of the v-packings face down in the throat.* See Fig. 5.
3. Loosely install the packing nut/wet-cup (2).
4. Install the other packing stack (29*) on the piston (3). **Do not** disassemble the stack. *Be sure the lips of the v-packings face up on the piston.* See Fig. 6.

NOTE: In step 5, use thread sealant on the piston for Model 224–435 only. **Do not use thread sealant on the stainless steel piston of Model 223–584.**

5. Place the washer (16) and ball (6*) on the piston, and screw the piston assembly into the displacement rod (22), torquing to 150–175 ft-lb (203–237 N.m). See Fig. 4.
6. Lubricate the displacement rod (22). Carefully guide the rod into the bottom of the pump housing (1), and push it up through the throat packings.
7. Install the o-ring (9*) and retainer (12) on the intake valve housing (4). Install the ball (7*), ball guide (13), and ball stop pin (11) in the intake valve housing. Be sure the pin (11) is in the desired set of holes. Refer to **Check Valve Adjustment**. Screw the assembly into the pump housing (1).
8. Reconnect the displacement pump to the motor (see your separate pump manual). Reconnect the ground wire if it was disconnected during repair.
9. Follow the **Pressure Relief Procedure** on page 2. Tighten the throat packing nut (2) just enough to prevent leakage, but no tighter. Use the wrench supplied with the complete pump. Fill the wet-cup half full with TSL or compatible solvent.

Check Valve Adjustment

The intake check valve is set for high flow rates or high viscosity fluids. To set the valve for lighter viscosity fluids or a lower flow rate, to minimize surging at pump stroke changeover, move the ball stop pin (11) to the lower set of holes, decreasing the check ball travel. To adjust the piston check valve for use with very light viscosity fluids, refer to **Accessories** on page 11.

Detail of Throat Gland/Packing Stack

- 1 Lips of v-packings must face down.
- 2 Remove shims from packing stack before installing in throat.

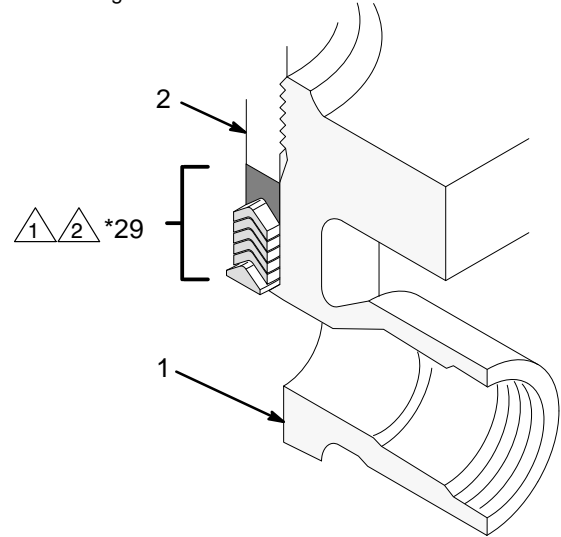

02523

Fig. 5

Detail of Piston Gland/Packing Stack

- 1 Lips of v-packings must face up.
- 2 Do not disassemble stack when installing in pump.

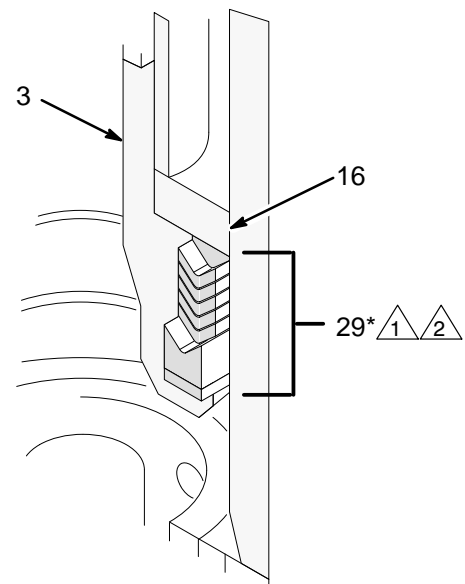

02523

Fig. 6

Parts

Model 224-435, Series B

Ref No.	Part No.	Description	Qty
1	207-470	HOUSING, pump; carbon steel	1
2	207-471	PACKING NUT/WET-CUP; carbon steel	1
3✓	207-472	PISTON; carbon steel with tungsten carbide seat	1
4	207-473	HOUSING, intake valve; carbon steel with tungsten carbide seat	1
6*	102-972	BALL, stainless steel; 7/8" dia.	1
7*	102-973	BALL, stainless steel; 1-1/4" dia.	1
9*	106-260	O-RING; PTFE	1
11	167-890	PIN, ball stop, intake valve; carbon steel	1
12	167-891	RETAINER; carbon steel	1
13	167-892	GUIDE, ball; carbon steel	1
14	178-894	SLEEVE; stainless steel	1
15*	167-894	GASKET; PTFE	1
16✓	167-895	WASHER, flat; carbon steel	1
22	236-278	ROD, displacement; stainless steel	1
26▲	172-479	TAG, warning (not shown)	1
29*	223-480	GLAND/PACKING STACK; Leather with PTFE backup	2

* These parts are included in Repair Kit 224-438, which may be purchased separately. The kit includes a tube of 102-969 thread sealant for use on the piston (3).

✓ Keep these spare parts on hand to reduce down time.

▲ Replacement Danger and Warning labels, tags and cards are available at no cost.

Manual Change Summary

Model 237-406 PTFE packed pump is added to the manual.

- 1 Lips of v-packings must face down.
- 2 Remove shims from packing stack before installing in throat.
- 3 Lips of v-packings must face up.
- 4 Do not disassemble stack when installing on piston.
- 5 Male Gland
- 6 Female Gland
- 7 PTFE V-Packing
- 8 Leather V-Packing
- 9 Shim

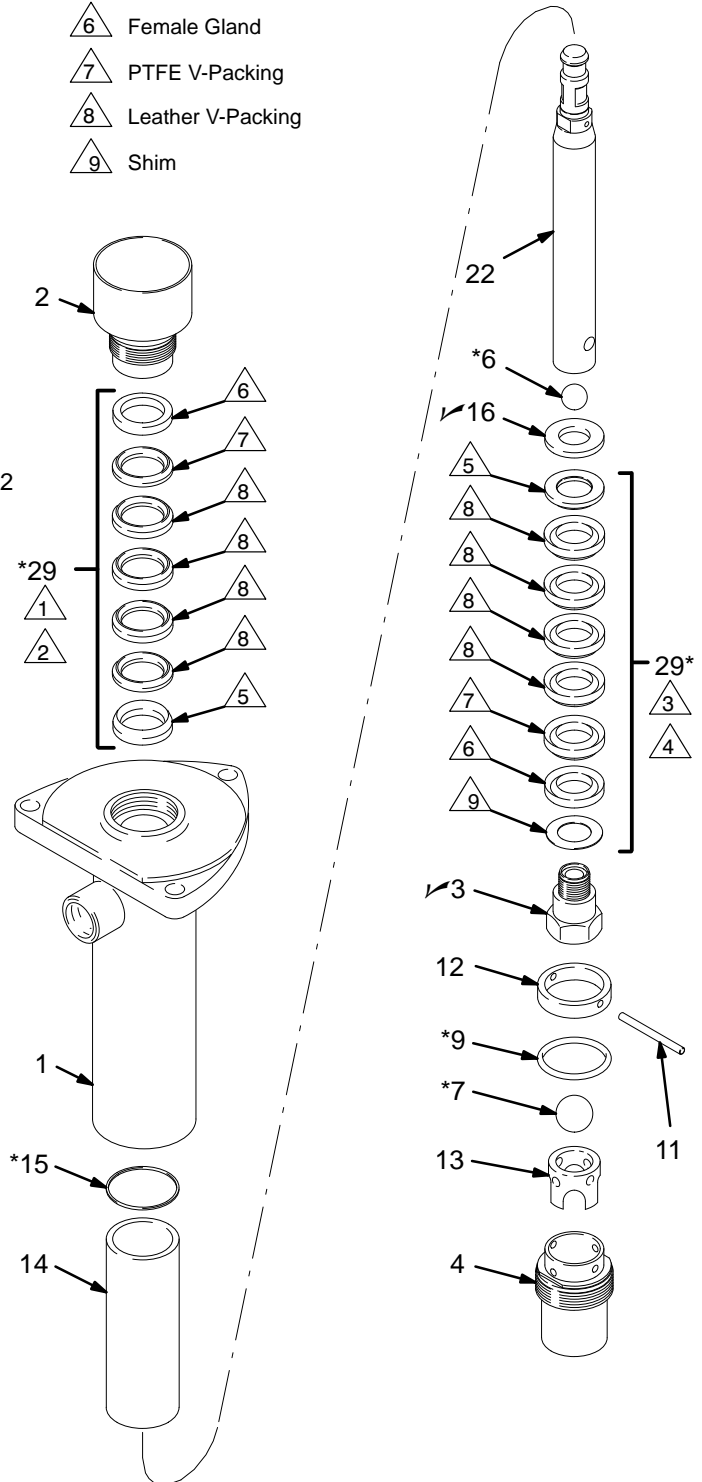

02522

Parts

Model 223-584, Series C

Ref No.	Part No.	Description	Qty
1	207-470	HOUSING, pump; carbon steel	1
2	207-471	PACKING NUT/WET-CUP; carbon steel	1
3✓	223-560	PISTON; stainless steel with tungsten carbide seat	1
4	223-561	HOUSING, intake valve; stainless steel with tungsten carbide seat	1
6*	109-217	BALL, stainless steel; 7/8" dia.	1
7*	109-219	BALL, stainless steel; 1-1/4" dia	1
9*	106-260	O-RING; PTFE	1
11	186-160	PIN, ball stop, intake valve; stainless steel	1
12	186-165	RETAINER; stainless steel	1
13	186-161	GUIDE, ball; stainless steel	1
14	178-894	SLEEVE; stainless steel	1
15*	167-894	GASKET; PTFE	1
16✓	186-159	WASHER, flat; stainless steel	1
22	236-278	ROD, displacement; stainless steel	1
26▲	172-479	TAG, warning (not shown)	1
29*	223-642	GLAND/PACKING STACK; Leather with PTFE backup	2

* These parts are included in Repair Kit 223-643, which may be purchased separately.

✓ Keep these spare parts on hand to reduce down time.

▲ Replacement Danger and Warning labels, tags and cards are available at no cost.

- 1 Lips of v-packings must face down.
- 2 Remove shims from packing stack before installing in throat.
- 3 Lips of v-packings must face up.
- 4 Do not disassemble stack when installing on piston.
- 5 Male Gland
- 6 Female Gland
- 7 PTFE V-Packing
- 8 Leather V-Packing
- 9 Shim

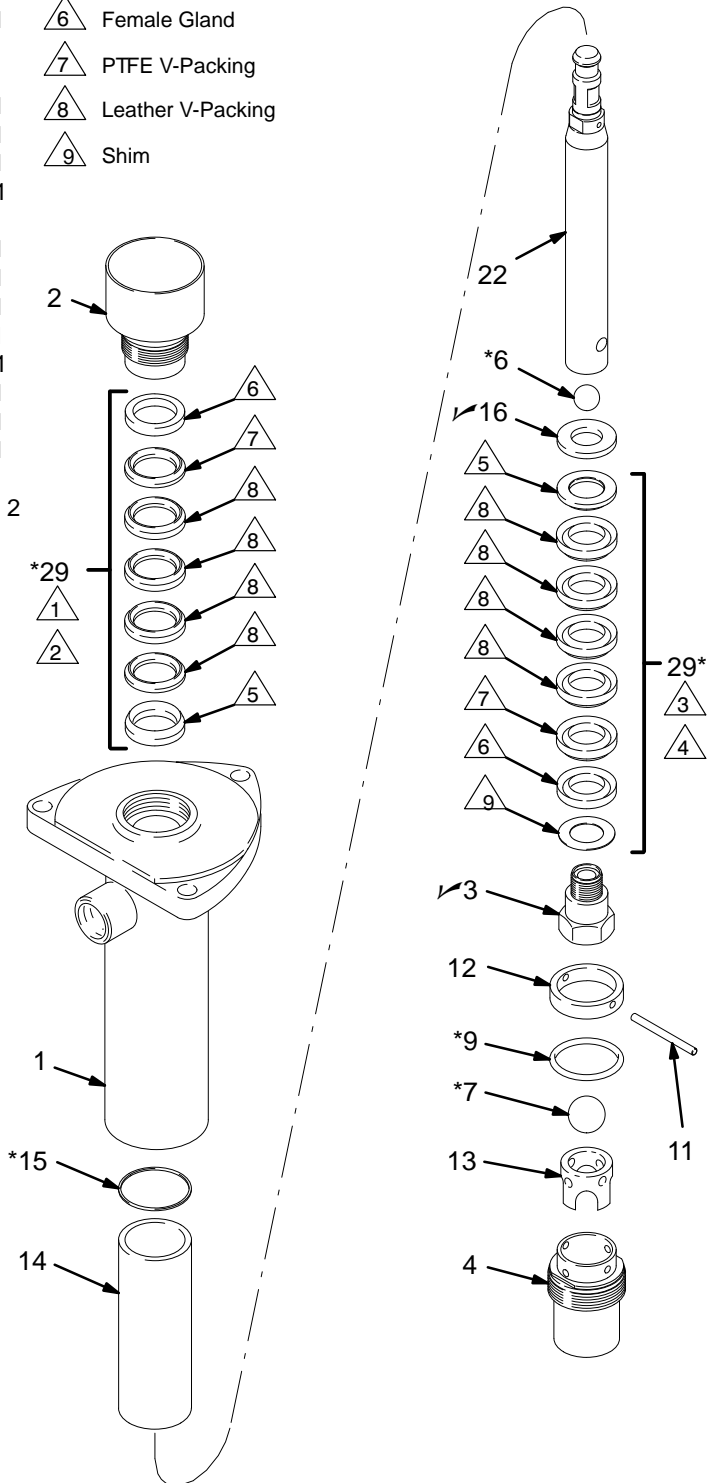

Accessories

Piston Ball Stop Bolt 220-420

Use in place of standard piston ball stop when pumping very light viscosity fluids. Decreases piston ball travel, improves action of piston ball check, and minimizes hammering and seat wear. Apply medium strength thread locking sealant, screw into bottom of displacement rod, and torque to 55-60 in-lb (6.2-6.8 N.m).

Technical Data

Maximum working pressure	4500 psi (315 bar)
Fluid inlet size	1-1/2" npt(f)
Fluid outlet size	1" npt(f)
Wetted parts	
Model 217-527	304, 440 and 17-4 PH Grade Stainless Steel, Carbon Steel, Tungsten Carbide, Chrome and Zinc Plating, PTFE, Leather, Ultra-High Molecular Weight Polyethylene
Model 237-406	304, 440 and 17-4 PH Grade Stainless Steel, Carbon Steel, Tungsten Carbide, Chrome and Zinc Plating, PTFE
Model 224-435	304, 440 and 17-4 PH Grade Stainless Steel, Carbon Steel, Tungsten Carbide, Chrome and Zinc Plating, PTFE, Leather
Model 223-584	304, 316, 329 and 17-4 PH Grade Stainless Steel, Carbon Steel, Tungsten Carbide, Chrome and Zinc Plating, PTFE, Leather

PTF[®] is a registered trademark

The Graco Warranty and Disclaimers

WARRANTY

Graco warrants all equipment manufactured by it and bearing its name to be free from defects in material and workmanship on the date of sale by an authorized Graco distributor to the original purchaser for use. As purchaser's sole remedy for breach of this warranty, Graco will, for a period of twelve months from the date of sale, repair or replace any part of the equipment proven defective. This warranty applies only when the equipment is installed, operated and maintained in accordance with Graco's written recommendations.

This warranty does not cover, and Graco shall not be liable for, any malfunction, damage or wear caused by faulty installation, misapplication, abrasion, corrosion, inadequate or improper maintenance, negligence, accident, tampering, or substitution of non-Graco component parts. Nor shall Graco be liable for malfunction, damage or wear caused by the incompatibility with Graco equipment of structures, accessories, equipment or materials not supplied by Graco, or the improper design, manufacture, installation, operation or maintenance of structures, accessories, equipment or materials not supplied by Graco.

This warranty is conditioned upon the prepaid return of the equipment claimed to be defective to an authorized Graco distributor for verification of the claim. If the claimed defect is verified, Graco will repair or replace free of charge any defective parts. The equipment will be returned to the original purchaser transportation prepaid. If inspection of the equipment does not disclose any defect in material or workmanship, repairs will be made at a reasonable charge, which charges may include the costs of parts, labor and transportation.

DISCLAIMERS AND LIMITATIONS

THE TERMS OF THIS WARRANTY CONSTITUTE PURCHASER'S SOLE AND EXCLUSIVE REMEDY AND ARE IN LIEU OF ANY OTHER WARRANTIES (EXPRESS OR IMPLIED), INCLUDING WARRANTY OF MERCHANTABILITY OR WARRANTY OF FITNESS FOR A PARTICULAR PURPOSE, AND OF ANY NON-CONTRACTUAL LIABILITIES, INCLUDING PRODUCT LIABILITIES, BASED ON NEGLIGENCE OR STRICT LIABILITY. EVERY FORM OF LIABILITY FOR DIRECT, SPECIAL OR CONSEQUENTIAL DAMAGES OR LOSS IS EXPRESSLY EXCLUDED AND DENIED. IN NO CASE SHALL GRACO'S LIABILITY EXCEED THE AMOUNT OF THE PURCHASE PRICE. ANY ACTION FOR BREACH OF WARRANTY MUST BE BROUGHT WITHIN TWO (2) YEARS OF THE DATE OF SALE.

EQUIPMENT NOT COVERED BY GRACO WARRANTY

GRACO MAKES NO WARRANTY, AND DISCLAIMS ALL IMPLIED WARRANTIES OF MERCHANTABILITY AND FITNESS FOR A PARTICULAR PURPOSE, WITH RESPECT TO ACCESSORIES, EQUIPMENT, MATERIALS, OR COMPONENTS SOLD BUT NOT MANUFACTURED BY GRACO. These items sold, but not manufactured by Graco (such as electric motor, switches, hose, etc.) are subject to the warranty, if any, of their manufacturer. Graco will provide purchaser with reasonable assistance in making any claim for breach of these warranties.

Graco Phone Numbers

TO PLACE AN ORDER, contact your Graco distributor, or call this number to identify the distributor closest to you: **1-800-367-4023 Toll Free**

FOR TECHNICAL ASSISTANCE, service repair information or assistance regarding the application of Graco equipment: **1-800-543-0339 Toll Free**

Sales Offices: Atlanta, Chicago, Dallas, Detroit, Los Angeles, Mt. Arlington (N.J.)
Foreign Offices: Canada; England; Korea; Switzerland; France; Germany; Hong Kong; Japan

GRACO INC. P.O. BOX 1441 MINNEAPOLIS, MN 55440-1441

PRINTED IN U.S.A. 307-728 2/85 Revised 8/94