

# INSTRUCTIONS-PARTS LIST



308-111

Rev A

This manual contains **IMPORTANT INSTRUCTIONS and WARNINGS.**  
READ AND RETAIN FOR REFERENCE.

King™ and Bulldog® Pumps,  
with Priming Piston and Leather Packings

## GREASE TRANSFER PUMPS

### 10:1 RATIO BULLDOG PUMP

1000 psi (70 bar) MAXIMUM WORKING PRESSURE

Model 224-102  
400 lb. drum size

### 25:1 RATIO BULLDOG PUMP

2500 psi (175 bar) MAXIMUM WORKING PRESSURE

Model 223-896  
400 lb. drum size

Model 223-897  
Stubby size

### 40:1 RATIO BULLDOG PUMP

4000 psi (280 bar) MAXIMUM WORKING PRESSURE

Model 223-899  
400 lb. drum size

Model 223-900  
Stubby size

### 20:1 RATIO KING PUMP

1800 psi (124 bar) MAXIMUM WORKING PRESSURE

Model 224-103  
400 lb. drum size

### 55:1 RATIO KING PUMP

5000 psi (345 bar) MAXIMUM WORKING PRESSURE

Model 223-898  
400 lb. drum size

Model 224-101  
Stubby size

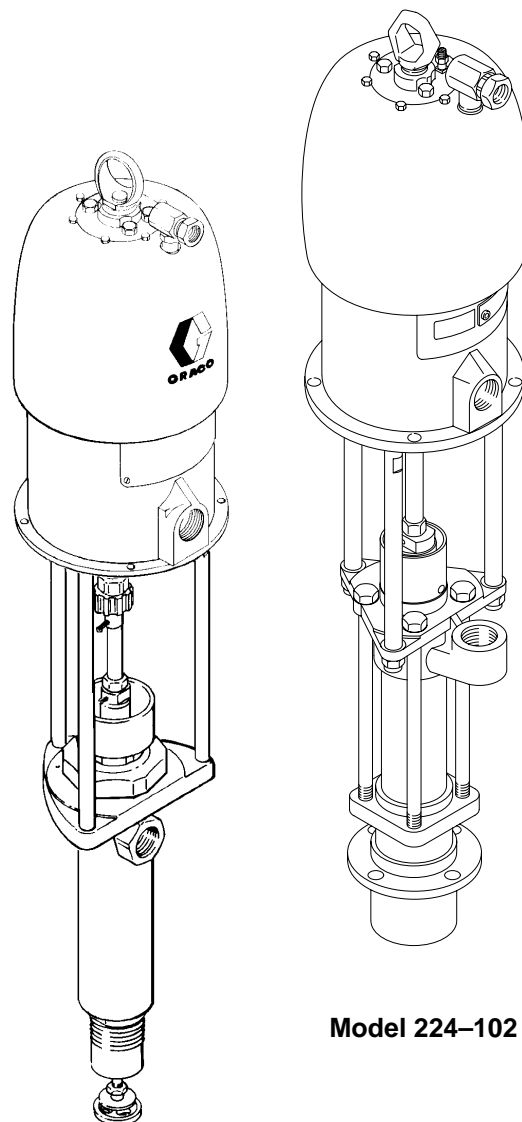

Table of Contents on page 3

Model 223-899

Model 224-102

THIS PAGE IS BLANK

## TABLE OF CONTENTS

|  |            |
|--|------------|
| Terms .....  | 3          |
| Warnings .....                                     | 4          |
| Installation .....                                 | 6          |
| Operation .....                                    | 7          |
| Maintenance .....                                  | 8          |
| Troubleshooting Guide .....                        | 8, 9       |
| Displacement Pump Service .....                    | 10         |
| Parts Lists And Drawings                           |            |
| 25:1 Ratio Bulldog and 55:1 Ratio King Pumps ..... | 16         |
| 20:1 King and 40:1 Ratio Bulldog Pumps .....       | 18         |
| Accessories .....                                  | 22         |
| Technical Data .....                               | 26         |
| Warranty .....                                     | Back Cover |

## TERMS

Be sure you read and understand each of these terms before reading the rest of the manual.

**WARNING** Alerts user to avoid or correct conditions which could cause bodily injury.

**CAUTION** Alerts user to avoid or correct conditions which may cause damage to or destruction of equipment.

**NOTE** Gives additional explanation of a procedure or helpful hints.

**PRESSURE RELIEF PROCEDURE** A safety procedure for relieving air and fluid pressure in the system.

**FLUID INJECTION INJURY** A serious injury, which may appear to be a simple cut, caused by the high pressure injection of fluid directly into the body.

# SAFETY WARNINGS

**HIGH PRESSURE FLUID CAN CAUSE SERIOUS INJURY. FOR PROFESSIONAL USE ONLY.**

**OBSERVE ALL WARNINGS. Read And Understand All Instruction Manuals Before Operating Equipment.**

## MOVING PARTS HAZARD

**KEEP HANDS AND FINGERS AWAY FROM THE PRIMING PISTON DURING OPERATION AND WHENEVER THE PUMP IS CHARGED WITH AIR to reduce the risk of injury!** On the pump downstroke the priming piston extends beyond the intake cylinder to pull the material into the pump. The priming piston works under extreme force. During operation and whenever the pump is charged with air, the priming piston can severely injure or amputate a hand or finger, or break a tool, caught between it and the intake cylinder. Always follow the **Pressure Relief Procedure**, below, before checking, clearing, cleaning, flushing or servicing any part of the pump.

## FLUID INJECTION HAZARD

### General Safety

This equipment conducts very high fluid pressure. Spray from the spray gun, leaks or ruptured components can inject fluid through your skin and into your body and cause extremely serious bodily injury, including the need for amputation. Also, fluid injected or splashed into the eyes or on the skin can cause serious damage.

NEVER point the spray gun at anyone or at any part of the body. NEVER put hand or fingers over the spray tip.

ALWAYS follow the **Pressure Relief Procedure**, right, before cleaning or removing the spray tip or servicing any system equipment.

NEVER try to stop or deflect leaks with your hand or body.

Be sure equipment safety devices are operating properly before each use.

### Medical Alert—Airless Spray Wounds

If any fluid appears to penetrate your skin, get **EMERGENCY MEDICAL CARE AT ONCE. DO NOT TREAT AS A SIMPLE CUT.** Tell the doctor exactly what fluid was injected.

**Note to Physician:** Injection in the skin is a traumatic injury. It is **important to treat the injury surgically as soon as possible.** Do not delay treatment to research toxicity. Toxicity is a concern with some exotic coatings injected directly into the blood stream. Consultation with a plastic surgeon or reconstructive hand surgeon may be advisable.

### Spray Gun Safety Devices

Be sure all spray gun safety devices are operating properly before each use. Do not remove or modify any part of the spray gun; this can cause a malfunction and result in serious bodily injury.

#### Safety Latch

Whenever you stop spraying, even for a moment, always set the spray gun safety latch in the closed or "safe" position, making the spray gun inoperative. Failure to set the safety latch can result in accidental triggering of the spray gun.

#### Trigger Guard

Never operate the spray gun with the trigger guard removed. This guard helps prevent the spray gun from triggering accidentally if it is dropped or bumped.

#### Diffuser (only on spray guns)

The spray gun diffuser breaks up spray and reduces the risk of fluid injection when the tip is not installed. Check the diffuser operation regularly. Follow the **Pressure Relief Procedure**, to the right, then remove the spray tip. Aim the spray gun into a grounded metal pail, holding the spray gun firmly to the pail. Using the lowest possible pressure, trigger the spray gun. If the fluid emitted is not diffused into an irregular stream, replace the diffuser immediately.

The air motor piston (located behind the air motor shield) also moves when air is supplied to the motor. NEVER operate the pump with the air motor shield removed. Before servicing the pump, follow the **Pressure Relief Procedure** below to prevent the pump from starting accidentally.

#### Tip Guard (only on spray guns)

ALWAYS have the tip guard in place on the spray gun while spraying. The tip guard alerts you to the fluid injection hazard and helps reduce, **but does not prevent**, the risk of accidental placing your fingers or any part of your body close to the spray tip.

#### Spray Tip/Nozzle Safety

Use extreme caution when cleaning or changing spray tips/nozzles. If the spray tip/nozzle clogs while spraying/dispensing, engage the spray gun safety latch immediately. ALWAYS follow the **Pressure Relief Procedure** and then remove the spray tip/nozzle to clean it.

NEVER wipe off build-up around the spray tip/nozzle until pressure is fully relieved and the spray gun safety latch is engaged.

### Pressure Relief Procedure

To reduce the risk of serious bodily injury, including fluid injection, splashing in the eyes or on the skin, or injury from moving parts, always follow this procedure whenever you shut off the pump, when checking or servicing any part of the spray/dispensing system, when installing, cleaning or changing spray tips/nozzles, and whenever you stop spraying/dispensing.

1. Engage the spray gun safety latch.
2. Shut off the air to the pump.
3. Close the bleed-type master air valve (required in your system).
4. Disengage the safety latch.
5. Hold a metal part of the spray gun firmly to the side of a grounded metal pail, and trigger the spray gun to relieve pressure.
6. Engage the spray gun safety latch.
7. Open the drain valve and/or the pump bleeder valve (required in your system), having a container ready to catch the drainage.
8. Leave the drain valve open until you are ready to spray/dispense again.

If you suspect that the spray tip/nozzle or hose is completely clogged, or that pressure has not been fully relieved after following the steps above, VERY SLOWLY loosen the retaining nut or hose end coupling and relieve pressure gradually, then loosen completely. Now clear the tip/nozzle or hose.

## EQUIPMENT MISUSE HAZARD

### General Safety

Any misuse of the spray equipment or accessories, such as overpressurizing, modifying parts, using incompatible chemicals and fluids, or using worn or damaged parts, can cause them to rupture and result in fluid injection, splashing in the eyes or on the skin, or other serious bodily injury, or fire, explosion or property damage.

NEVER alter or modify any part of this equipment; doing so could cause it to malfunction.

CHECK all spray equipment regularly and repair or replace worn or damaged parts immediately.

Always wear protective eyewear, gloves, clothing and respirator as recommended by the fluid and solvent manufacturer.

## HOSE SAFETY

High pressure fluid in the hoses can be very dangerous. If the hose develops a leak, split or rupture due to any kind of wear, damage or misuse, the high pressure spray emitted from it can cause a fluid injection injury or other serious bodily injury or property damage.

**ALL FLUID HOSES USED WITH A FLEXING MOTION MUST HAVE SPRING GUARDS ON BOTH ENDS!** The spring guards help protect the hose from kinks or bends at or close to the coupling which can result in hose rupture.

**TIGHTEN** all fluid connections securely before each use. High pressure fluid can dislodge a loose coupling or allow high pressure spray to be emitted from the coupling.

NEVER use a damaged hose. Before each use, check the entire hose for cuts, leaks, abrasion, bulging cover, or damage or movement of the hose couplings. If any of these conditions exist, replace the hose immediately. DO NOT try to recouple high pressure hose or mend it with tape or any other device. A repaired hose cannot safely contain the high pressure fluid.

## FIRE OR EXPLOSION HAZARD

Static electricity is created by the high velocity flow of fluid through the pump and hose. If every part of the spray equipment is not properly grounded, sparking may occur, and the system may become hazardous. Sparking may also occur when plugging in or unplugging a power supply cord. Sparks can ignite fumes from solvents and the fluid being sprayed, dust particles and other flammable substances, whether you are spraying indoors or outdoors, and can cause a fire or explosion and serious bodily injury and property damage. Do not plug in or unplug any power supply cords in the spray area when there is any chance of igniting fumes still in the air.

If you experience any static sparking or even a slight shock while using this equipment, **STOP SPRAYING IMMEDIATELY**. Check the entire system for proper grounding. Do not use the system again until the problem has been identified and corrected.

### To ground the pump:

To ground the pump, loosen the grounding lug locknut (A) and washer (B). Insert one end of a 1.5 mm<sup>2</sup> (12 ga) minimum ground wire (D) into the slot in lug (C) and tighten the locknut securely. See Fig 1. Connect the other end of the wire to a true earth ground. See **ACCESSORIES** on page 22 to order a ground wire and clamp.

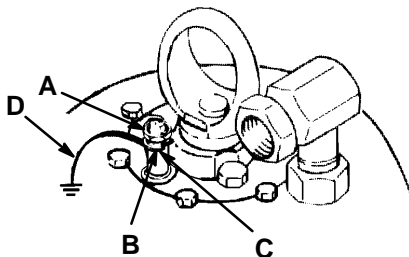

Fig 1

### System Pressure

NEVER exceed the recommended working pressure or the maximum air inlet pressure stated on your pump or in the **TECHNICAL DATA** on page 26.

Be sure that all spray/dispensing equipment and accessories are rated to withstand the maximum working pressure of the pump. DO NOT exceed the maximum working pressure of any component or accessory used in the system.

### Fluid Compatibility

BE SURE that all fluids and solvents used are chemically compatible with the wetted parts shown in the **TECHNICAL DATA** on page 26. Always read the manufacturer's literature before using fluid or solvent in this pump.

**HANDLE AND ROUTE HOSES CAREFULLY.** Do not pull on hoses to move equipment. Do not use fluids which are not compatible with the inner tube and cover of the hose. DO NOT expose Graco hoses to temperatures above 82° C (180° F) or below -40° C (-40° F).

### Hose Grounding Continuity

Proper hose grounding continuity is essential to maintaining a grounded spray system. Check the electrical resistance of your air and fluid hoses at least once a week. If your hose does not have a tag on it which specifies the maximum electrical resistance, contact the hose supplier or manufacturer for the maximum resistance limits. Use a resistance meter in the appropriate range for your hose to check the resistance. If the resistance exceeds the recommended limits, replace it immediately. An ungrounded or poorly grounded hose can make your system hazardous. Also, read **FIRE OR EXPLOSION HAZARD**, below.

## Grounding

To reduce the risk of static sparking, ground the pump, object being sprayed, and all other spray equipment used or located in the spray area. CHECK your local electrical code for detailed grounding instructions for your area and type of equipment. BE SURE to ground all of this spray equipment:

1. *Pump*: use a ground wire and clamp. See Fig 1.
2. *Air hoses*: use only grounded air hoses.
3. *Fluid hoses*: use only grounded fluid hoses.
4. *Air compressor*: follow manufacturer's recommendations.
5. *Spray gun*: grounding is obtained through connection to a properly grounded fluid hose and pump.
6. *Fluid supply container*: according to your local code.
7. *Object being sprayed*: according to your local code.
8. *All solvent pails used when flushing*, according to your local code. Use only metal pails, which are conductive, placed on a grounded surface. Do not place the pail on a nonconductive surface, such as paper or cardboard, which interrupts the grounding continuity.
9. *To maintain grounding continuity when flushing or relieving pressure*, always hold a metal part of the spray gun firmly to the side of a grounded *metal* pail, then trigger the spray gun.

### Flushing Safety

Before flushing, be sure the entire system and flushing pails are properly grounded. Refer to **Grounding**, above. Follow the **Pressure Relief Procedure** on page 4, and remove the spray tip/nozzle from the spray gun. Always use the lowest possible fluid pressure, and maintain firm metal-to-metal contact between the spray gun and the pail during flushing to reduce the risk of fluid injection injury, static sparking and splashing.

## IMPORTANT

United States Government safety standards have been adopted under the Occupational Safety and Health Act. These standards – particularly the General Standards, Part 1910, and the Construction Standards, Part 1926 – should be consulted.

# INSTALLATION

## TYPICAL INSTALLATION

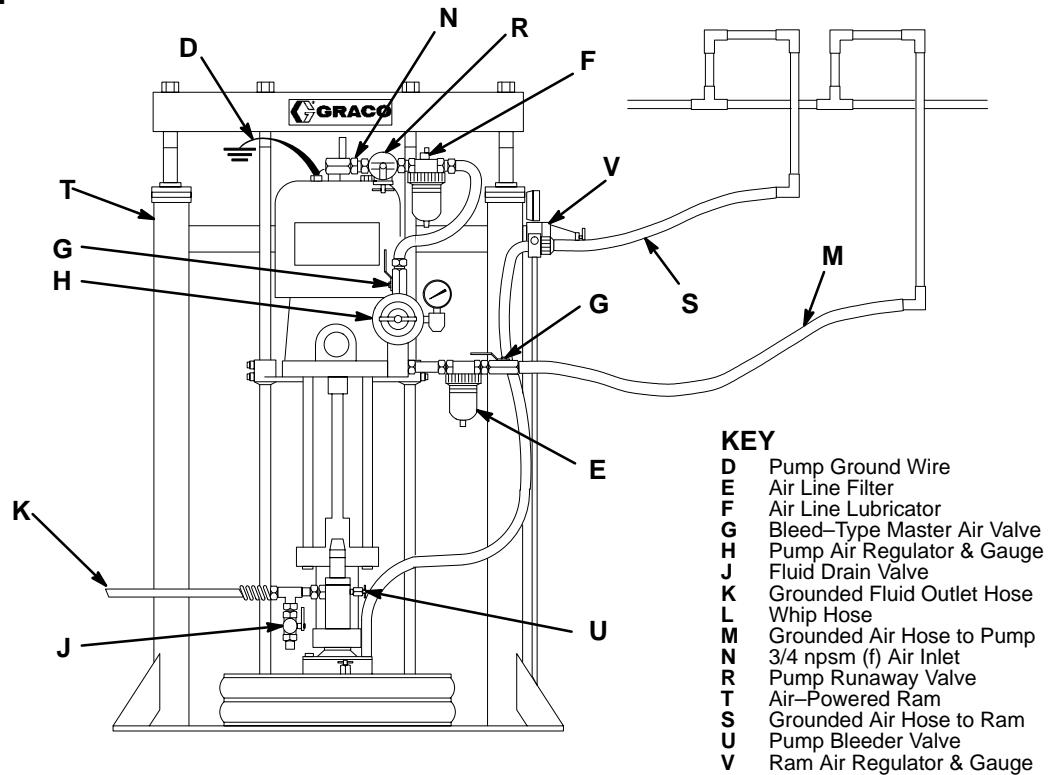

The reference numbers and letters in parentheses in the text correspond to the callouts in Figures 1–7 and the Parts Drawing.

See pages 22 – 24 for accessories available from Graco. Be sure all accessories are properly sized to withstand the pressures in the system.

The Typical Installation shown above is only a guide to selecting and installing required and optional accessories. For assistance in designing a system to suit your particular needs, contact your Graco representative or Graco Technical Assistance.

If you are using a ram or standpipe, refer also to its separate instruction manual.

### Accessories

Install the accessories in the order shown in the Typical Installation drawing. The air line filter (E) removes harmful dirt and moisture from the compressed air supply. The air regulator (H) controls pump speed and outlet pressure. The bleed-type master air valve (G) relieves air trapped between it and the pump when it is closed. The air line lubricator (F) provides automatic air motor lubrication. Be sure the valve is easily accessible from the pump. The pump runaway valve (R) senses when the pump is running too fast and shuts off the air supply to the motor.

Be sure the pump air line (M) is properly grounded, and is large enough to supply an adequate volume of air to the motor. An air-powered ram (T) requires a separate grounded air supply line (S).

### WARNING

Two accessories are required in your system: a bleed-type master air valve (G) and a fluid drain valve (J). These accessories help reduce the risk of serious bodily injury including fluid injection, splashing in the eyes or on the skin, and injury from moving parts if you are adjusting or repairing the pump.

The bleed-type master air valve relieves air trapped between this valve and the pump after the air is shut off. Trapped air can cause the pump to cycle unexpectedly. Locate the valve close to the pump.

The fluid drain valve assists in relieving fluid pressure in the displacement pump, hose and dispense valve; triggering the dispense valve; to relieve pressure may not be sufficient.

Use a suitable adapter to install a fluid drain valve (J) near the 1 in. npt(f) pump fluid outlet. Connect a grounded fluid outlet hose (K) to the outlet.

### GROUNDING

#### WARNING

Before operating the pump, ground the system as explained under **FIRE OR EXPLOSION HAZARD** and **Grounding** on page 5.

## OPERATION

### WARNING

To reduce the risk of serious bodily injury, including fluid injection, splashing in the eyes or on the skin, or injury from moving parts, always follow the **Pressure Relief Procedure Warning** on page 8 whenever you shut off the pump, when checking or servicing any part of the spray/dispensing system, when installing, cleaning or changing spray tips or nozzles, and whenever you stop spraying.

### WARNING

Moving parts can pinch or amputate your fingers or other body parts. When the pump is operating, the priming piston (Q) (located at the pump intake) and the air motor piston (located behind the air motor shield) move. Therefore, NEVER operate the pump with the air motor shield removed, and keep your fingers and hands away from the priming piston.

Before attempting to clear an obstruction from the priming piston (Q) or service the pump, follow the **Pressure Relief Procedure Warning** on page 8 to prevent the pump from starting accidentally.

### Flush the Pump

The pump is tested with lightweight oil, which is left in to protect the pump parts. If the fluid you are using may be contaminated by the oil, flush it out with a compatible solvent before using the pump.

### WARNING

**For your safety**, read the warning section, **FIRE OR EXPLOSION HAZARD** on page 5 before flushing, and follow all the recommendations given there.

**NOTE:** In a grease transfer operation, be sure the transfer hose is securely installed in the receiving container.

### Start and Adjust the Pump

1. Be sure the air regulator (H) is closed. Then open the bleed-type master air valve (G).
2. In a manual dispense system only, hold a metal part of the dispense valve firmly to the side of a grounded metal pail and hold the trigger open.
3. Now slowly open the air regulator until the pump runs slowly and smoothly.
4. If the pump fails to prime properly, open the bleeder valve (139) slightly. Do not open it all the way; the handle can come off. Cover the bleeder valve hole with something **other than your hand or fingers** and use the hole as a priming valve until the fluid appears at the hole. See Fig 2. Close the bleeder valve.

### WARNING

To reduce the risk of fluid injection, DO NOT use your hand or fingers to cover the bleeder hole when priming the pump.

5. Cycle the pump slowly until all the air is pushed out and the pump and hoses are fully primed.
6. In a manual dispense system only, release the dispense valve trigger and engage the safety latch (if applicable). The pump will stall against pressure when the trigger is released. With the pump and lines primed, and with adequate air pressure and volume supplied, the pump will start and stop as the dispense valve is opened and closed.
7. In a grease transfer operation, shut off the pump air to stop the pump.
8. Use the air regulator to control the pump speed and the fluid pressure. Always use the lowest air pressure necessary to get the desired results. Higher pressures cause premature tip/nozzle and pump wear.

### WARNING

To reduce the risk of overpressurizing your system, which could result in component rupture and cause serious bodily injury, NEVER exceed the maximum air and fluid working pressure of the lowest rated component in your system. See **EQUIPMENT MISUSE HAZARD, System Pressure**, on page 5.

### Never Allow The Pump To Run Dry

A dry pump will quickly accelerate to a high speed, possibly damaging itself. A pump runaway valve, which shuts off the air supply to the pump if the pump accelerates beyond the pre-set speed, is available. See **ACCESSORIES** on page 22. If your pump accelerates quickly, or is running too fast, stop it immediately and check the fluid supply. If the supply container is empty and air has been pumped into the lines, refill the container and prime the pump and the lines with fluid, or flush and leave it filled with a compatible solvent. Be sure to eliminate all air from the fluid system.

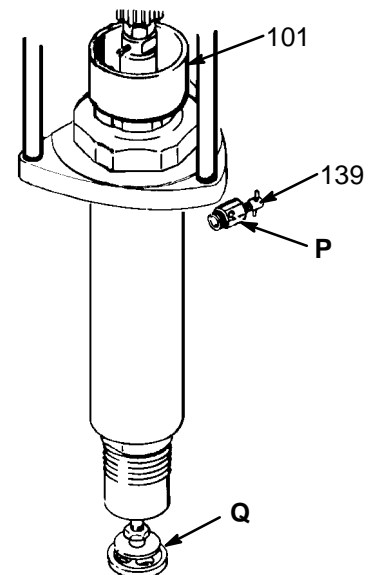

Fig 2

## MAINTENANCE

### Shutdown and Care of the Pump

For overnight shutdown, follow the **Pressure Relief Procedure Warning**, below. Always stop the pump at the bottom of the stroke to prevent the fluid from drying on the exposed displacement rod and damaging the throat packings.

### Flush Regularly and Before Storing the Pump

Always flush the pump before the fluid dries on the displacement rod. Never leave water or water-based fluid in the pump overnight. First, flush with water or a compatible solvent, then with mineral spirits. Relieve the pressure, but leave the mineral spirits in the pump to protect the parts from corrosion.

### WARNING

#### Moving Parts Hazard

Moving parts can pinch or amputate your fingers or other body parts. When the pump is operating, the priming piston (located at the pump intake) and the air motor piston (located behind the air motor shield) move. Therefore, NEVER operate the pump with the air motor shield removed, and keep your fingers and hands away from the priming piston.

Before attempting to clear an obstruction from the priming piston or service the pump, follow the **Pressure Relief Procedure Warning**, below, to prevent the pump from starting accidentally.

## TROUBLESHOOTING GUIDE

### WARNING

#### Pressure Relief Procedure

To reduce the risk of serious bodily injury, including fluid injection, splashing in the eyes or on the skin, or injury from moving parts, always follow this procedure whenever you shut off the pump, when checking or servicing any part of the spray/dispensing system, when installing, cleaning or changing spray tips/nozzles, and whenever you stop spraying/dispensing.

1. Engage the spray gun safety latch.
2. Shut off the air to the pump.
3. Close the bleed-type master air valve (required in your system).
4. Disengage the safety latch.

5. Hold a metal part of the spray gun firmly to the side of a grounded metal pail, and trigger the spray gun to relieve pressure.
6. Engage the spray gun safety latch.
7. Open the drain valve and/or the pump bleeder valve (required in your system), having a container ready to catch the drainage.
8. Leave the drain valve open until you are ready to use the system again.

If you suspect that the spray tip/nozzle or hose is completely clogged, or that pressure has not been fully relieved after following the steps above, VERY SLOWLY loosen the retaining nut or hose end coupling and relieve pressure gradually, then loosen completely. Now clear the tip/nozzle or hose.

**NOTE:** Check everything in the guide on page 9 before disassembling the pump.



## TROUBLESHOOTING GUIDE

| PROBLEM  | CAUSE   | SOLUTION  |
|--|---|---|
| Pump fails to operate                              | Restricted line or inadequate air supply                      | Clear; see <b>TECHNICAL DATA</b> on page 26.  |
|  | Insufficient air pressure; closed or clogged air valves, etc. | Increase air pressure, open or clear clogged valves.  |
|  | Obstructed fluid hose or dispense valve                       | Clear.*   |
|  | Dirty or worn air motor parts                                 | Disassemble and clean. See air motor manual, supplied. Be sure to use filtered air.           |
|  | Air motor ices up   | Reduce air line moisture content.**   |
| Pump operates, but:<br>–output low on both strokes | Restricted line or inadequate air supply                      | Clear; see <b>TECHNICAL DATA</b> on page 26.  |
|  | Insufficient air pressure; closed or clogged air valves, etc. | Increase air pressure, open or clear clogged valves.  |
|  | Obstructed fluid hose or dispense valve                       | Clear.*   |
|  | Bleeder valve open  | Close.  |
|  | Air leaking into supply container                             | Check seals on mounting device (ram, floor stand, etc.)                                       |
|  | Fluid too heavy for pump priming                              | Use bleeder valve. See page 7. Use inductor or ram, if applicable.                            |
|  | Worn throat packings in displacement pump.                    | Replace gland/packing stack.  |
|  | Air motor ices up   | Reduce air line moisture content.**   |
| –output low on downstroke                          | Fluid too heavy for pump priming.                             | Use bleeder valve. See page 7. Use inductor or ram, if applicable.                            |
|  | Held open or worn piston valve or packings                    | Clear valve; replace piston gland/packing stack.  |
|  | Air motor ices up   | Reduce air line moisture content.**   |
| –output low on upstroke                            | Held open or worn piston valve or packings.                   | Clear valve; replace piston gland/packing stack.  |
|  | Air motor ices up   | Reduce air line moisture content.**   |
| Erratic or accelerated pump speed                  | Exhausted fluid supply.                                       | Refill and prime. Use pump runaway valve to automatically stop pump when fluid supply is low. |
|  | Fluid too heavy for pump priming                              | Use bleeder valve. See page 7. Use inductor or ram, if applicable.                            |
|  | Held open or worn piston valve or packings                    | Clear valve; replace piston gland/packing stack.  |
|  | Held open or worn priming piston                              | Clear; service.   |
|  | Worn throat packings in displacement pump.                    | Replace gland/packing stack.  |
|  | Air motor ices up   | Reduce air line moisture content.**   |

\* To clear the pump, follow the **Pressure Relief Procedure Warning** on page 8. Disconnect the fluid line. If the pump starts when the air is turned on, then the fluid hose or dispensing valve is obstructed.

\*\* Be sure there is a vertical loop in the air line drop hose from the main air supply line. Also use an air and moisture separator (air filter) to minimize moisture in the air line.

## REPAIR – PUMP A & B

### WARNING

To reduce the risk of serious bodily injury, including injection, splashing in the eyes, or injury from moving parts, always follow the **Pressure Relief Procedure Warning** on page 8 before servicing any part of the system.

### WARNING

#### Priming Piston Hazard

Before attempting to clear an obstruction from the priming piston or service the pump, follow the **Pressure Relief Procedure Warning** on page 8 to prevent the pump from starting accidentally.

### Before you start

**NOTE:** PUMP A & B refer to the displacement pumps used in the 25:1 Bulldog/55:1 King pumps, and the 40:1 Bulldog pumps, respectively. The parts lists are shown on pages 17 and 19, respectively.

1. Repair Kits are available. See the Parts Lists pages, 17 and 19, for the kit contents. Use all the parts in the kits for the best results. Parts included in the kits are marked with a double asterisk, for example, (124\*\*), in the text and drawings. **Untie, but DO NOT disassemble the gland/packing stacks.**
2. Flush the pump with compatible solvent if possible. Relieve pressure. See the procedure on page 8.
3. Disconnect the hoses, remove the pump from its mounting, and clamp it in a vise.

### Disassembly

1. Refer to Fig 3 and the parts drawing unless otherwise noted.
2. Unscrew the coupling nut (9) and the tie rod locknuts (3). Remove the cotter pin (1), loosen the jam nut (5), and unscrew the connecting rod (11) from the displacement rod (108). Pull the displacement pump away from the motor.
3. Place the pump housing (109) in a padded jaw vise with the outlet (107) against one jaw.
4. Remove the packing nuts (136 and 140). Remove the throat packings (159) from the nut (140). See Fig 4.
5. Push the displacement rod (108) until the priming piston (119) clears the intake cylinder (117).
6. Use two wrenches to oppositely turn and loosen the hex nuts (120) on the piston rod (122).
7. Remove the valve plate (118), valve guide (121), and the priming piston (119).
8. Remove the intake cylinder (117) and o-ring (124).
9. Pull on the piston rod (122) to remove the displacement rod (108) from the pump housing (109).
10. Remove the cotter pin (126) and unthread the piston rod (122) from the piston valve (112).

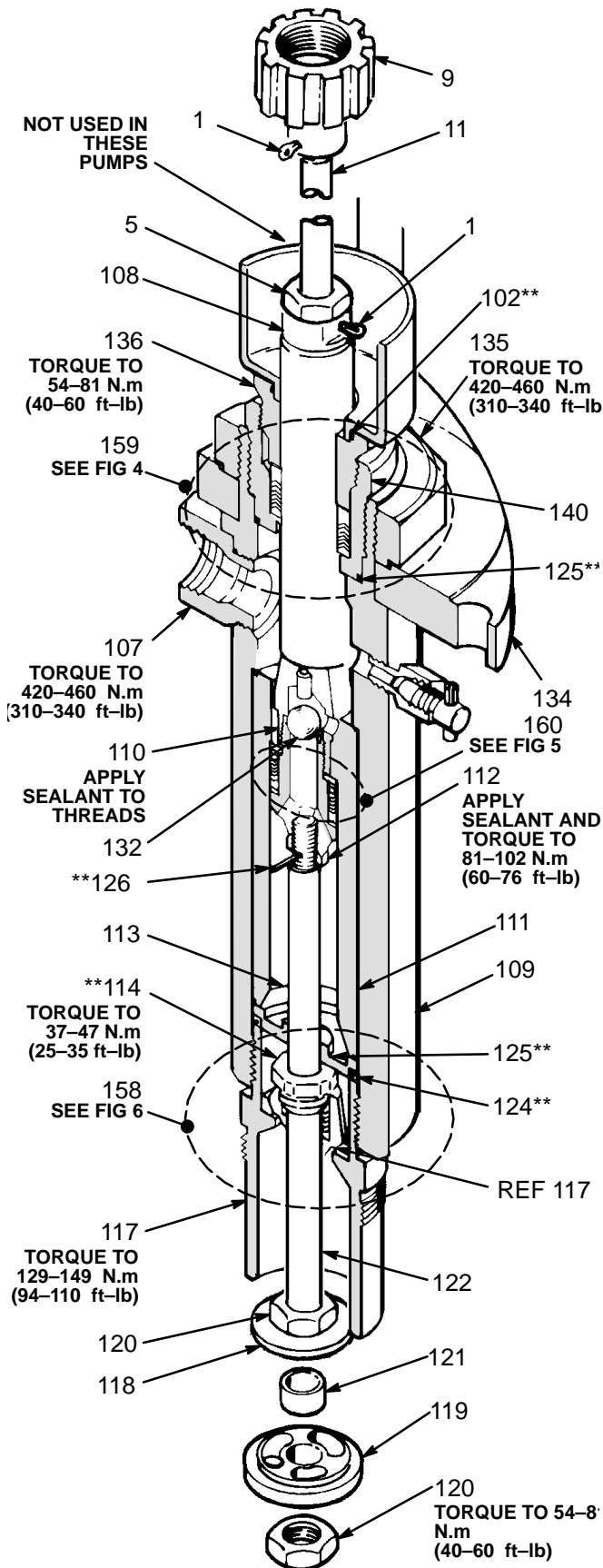

**Fig 3**

11. Remove the packing nut (114) from the piston rod (122). Remove the packings and female gland from the intake cylinder's packing housing (REF 117).

*Continued on page 11.*

## REPAIR – PUMP A & B

12. Unscrew the piston valve (112) from the piston valve housing (110), taking care not to drop the piston ball (132).
13. Remove the packings and glands from the piston.
14. Remove the cylinder (111) and o-rings (125). If the cylinder cannot be removed easily, contact the nearest Graco Technical Assistance or an authorized Service Agency for assistance.
15. Inspect the outer surface of the displacement rod (108) and the inner surface of the pump cylinder (111) for scoring and wear by holding them up to a light or running a finger over the surface. Replace these parts, if necessary. If the rod is worn, the packings will not seal properly and the pump will leak. If the cylinder is worn, the pump will not stall against pressure.
16. Clean all the parts in a compatible solvent, inspect them and replace them as necessary.

### Reassembly

**NOTE:** Lubricate the parts with a compatible lubricant before assembling.

1. Place an o-ring (125\*\*) on the packing nut (140). Screw the packing nut into the pump housing (109).
2. Refer to Fig 4. The gland/packing stack (159\*\*) for the throat is preassembled. **Untie, but DO NOT disassemble the stack.** Place the stack into the packing nut (140). *Be sure the lips of the v-packings are facing down.*

3. Place an o-ring (102\*\*) in the groove of the packing nut (136). Loosely install the packing nut (136) into the pump housing (109).

*Continued on page 12.*

### THROAT PACKINGS

LIPS OF V-PACKINGS  
MUST FACE DOWN

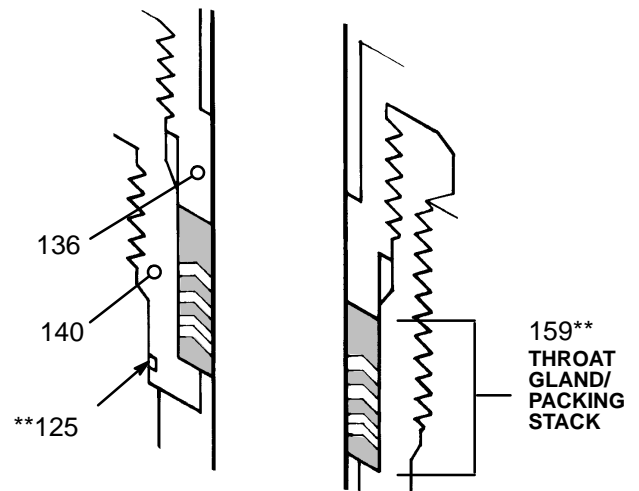

Fig 4

## PISTON PACKINGS

LIPS OF V-PACKINGS MUST FACE UP

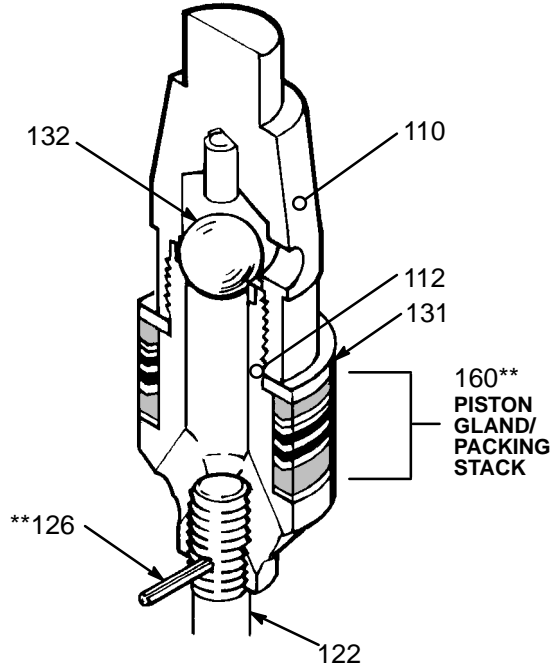

Fig 5

4. Slide the **assembled** gland/packing stack (160\*\*) onto the piston valve (112), *with the lips of the v-packings facing up*. Then place the backup washer (131) on top of the gland/packing stack. See Fig 5.
5. Install the piston ball (132) in the piston valve housing (110). Apply medium grade thread sealant to the threads of the piston valve (112) and housing (110). Screw the piston valve into the piston valve housing, torquing to 81–102 N.m (60–76 ft–lb). Screw the piston rod (122) into the piston valve, aligning the holes. Insert the cotter pin (126\*\*).
6. Place the pump housing (109) in the vise. Install the new o-rings (125\*\*) on the pump cylinder (111). Lubricate the cylinder and slide it into the pump housing as far as possible.
7. Slide the rod guide (113) onto the piston rod (122), with the flat side facing down.

8. Install the displacement rod assembly through the bottom of the pump, guiding it carefully through the throat packings.
9. Slide the **assembled** gland/packing stack (158\*\*) into the intake cylinder's packing housing (REF 117). *Be sure the lips of the v-packings are facing up*. Install the packing nut (114\*\*) and torque to 34–47 N.m (25–35 ft–lb). Slide this assembly, packing nut first, onto the piston rod (122). See Fig 6.
10. Place an o-ring (124\*\*) around the intake cylinder (117). Screw the cylinder into the pump housing (109). Torque to 129–149 N.m (94–110 ft–lb).
11. Thread the nut (120) onto the bottom of the piston rod. Install the valve plate (118), valve guide (121), priming piston (119), and the other nut (120).
12. Holding both nuts (120) with a wrench, torque the bottom nut to 54–81 N.m (40–60 ft–lb).
13. Tighten the packing nut (140). Torque the nut (136) to 54–81 N.m (40–60 ft–lb).
14. Reconnect the displacement pump (14) to the air motor (15). Reconnect the ground wire to the air motor if it was disconnected during service.

## INTAKE PACKINGS

LIPS OF V-PACKINGS MUST FACE UP

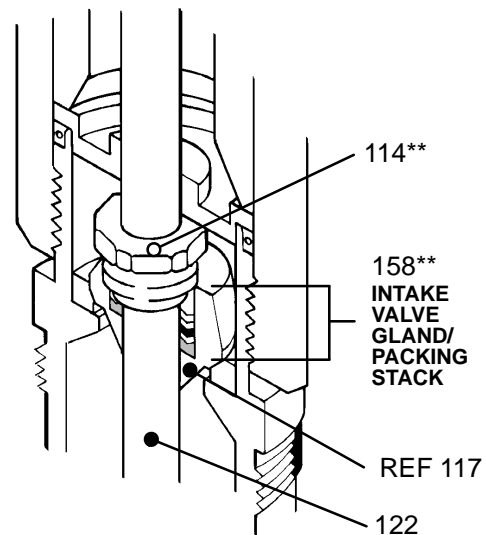

Fig 6



**WARNING**

To reduce the risk of serious bodily injury, including injection, splashing in the eyes, or injury from moving parts, always follow the **Pressure Relief Procedure Warning** on page 8 before servicing any part of the system.

**WARNING****Priming Piston Hazard**

Before attempting to clear an obstruction from the priming piston or service the pump, follow the **Pressure Relief Procedure Warning** on page 8 to prevent the pump from starting accidentally.

**Before you start**

**NOTE:** PUMP C refers to the displacement pump for the 10:1 Bulldog and 20:1 King pumps shown on page 21.

1. Repair Kit 224–147 is available. See page 21. For the best results, use all the new parts in the kit. Parts included in the kit are marked with an asterisk, for example (27\*\*), in the text and drawings. **Untie but DO NOT disassemble the gland/packing stacks.**
2. If possible, flush the pump before service with a compatible solvent. Relieve pressure. See the procedure on page 8.
3. Disconnect all the hoses. Remove the pump from its mounting and clamp it in a vise.

**Disassembly**

**NOTE:** Refer to Fig 7 and the parts drawing.

1. Remove the cotter pin (41). Unscrew the coupling nut (50) and the three tie rod locknuts (44). Pull the displacement pump (2) off the air motor (1).
2. Remove the cotter pin (42). Loosen the locknut (45). Unscrew the connecting rod (53) from the upper cap (33).
3. Insert a 1/4 in. (6 mm) diameter rod in the holes of the packing nut (21), and loosen it. Push the displacement rod (18) down until the priming piston (37) clears the intake valve housing (28). Remove the nut (6), priming piston (37), valve plate (36) and plate guide (31).
4. Unscrew the four tie bolts (8) and pull the intake valve housing (28) off the pump. Pull the priming rod (32) and displacement rod (18) out of the bottom of the cylinder (39). Remove the pin (7) and unscrew the priming rod (32) from the connecting rod (20).
5. Pull the cylinder (39) down out of the outlet housing (26). Inspect the inner surface of the cylinder and the outer surface of the displacement rod (18) for scratches or scoring, which can cause premature packing wear and leaking. To check, run a finger over the surface or hold the part up to the light at an angle.
6. Disassemble the intake valve (3). Clean and inspect all parts, replacing as necessary. Check the intake valve seat (30) for nicks or damage.

7. Unscrew the upper cap (33) from the connecting rod (20). Pull the displacement rod (18) off the lower cap (19), and remove the piston assembly from the connecting rod. Disassemble the piston.
8. Unscrew the packing nut (21). Remove the wiper seal (66). Remove the throat packings from the outlet housing (26).
9. Clean and inspect all parts, replacing as necessary.

**Reassembly**

**NOTE:** Refer to Fig 7 and the parts drawing during the following procedure.

1. See Detail A of Fig 7. **Untie, but DO NOT disassemble the gland/packing stack (64\*\*).** Lubricate the gland/packing stack and install it into the outlet housing (26). *Be sure the lips of the v-packings are facing down.* Install the wiper seal (66) in the groove of the packing nut (21) *with the lips facing down.* Loosely install the packing nut in the pump.
2. See Detail B of Fig 7. Install the two bearings (35\*\*) and the u-cup packing (56\*\*) on the piston (38). *Be sure the lips of the packing are facing up.* Install the small o-ring (15) in the lower cap (19) and the larger o-ring (17) on the outside of the lower cap.
3. Install the piston (38), valve plate (34), and lower cap (19) on the connecting rod (20).
4. Insert the connecting rod (20) into the displacement rod (18) so the lower cap (19) fits into the bottom of the displacement rod. Screw the top cap (33) onto the connecting rod (20) until it is tight against the top of the displacement rod (18).
5. Install one copper gasket (27\*\*) in the outlet housing (26). Screw the priming rod (32) into the connecting rod (20) and secure with the pin (7). Push the displacement rod (18) and priming rod (32) up into the outlet housing (26) so the top of the displacement rod just protrudes from the packing nut (21). Lubricate the priming rod (32).
6. Install the cylinder (39) in the outlet housing (26), being careful not to scratch the polished inner surface of the cylinder.
7. See Detail C of Fig 7. **Untie, but DO NOT disassemble the intake valve gland/packing stack (65\*\*).** Slide the stack into the intake valve seal housing (3). *Be sure the lips of the v-packings are facing up.* Tighten the packing nut (11). Install the valve seat (30) in the intake valve housing (28). Place the intake valve seal housing (3) on the seat (30).
8. Install two copper gaskets (27\*\*) on the intake valve stop (29). Install the stop in the intake valve housing (28).
9. Carefully guide the intake valve housing (28) up over the priming rod (32) and install it on the cylinder (39). Insert the four tie bolts (8) through the outlet housing (26) and engage the holes in the intake valve housing. Torque the tie bolts oppositely and evenly to 60 ft–lb (82 N.m).

## REPAIR – PUMP C

10. Install the plate guide (31), plate (36), priming piston (37) and nut (6) on the priming rod (32). If necessary, push down on the displacement rod (18) to provide sufficient clearance from the intake valve housing (28).
11. Tighten the packing nut (21) just enough to prevent leakage – no tighter.
12. Check the alignment of the displacement rod (18) by inserting a size E (0.254 in. diameter) drill shank between the packing nut (21) and the rod. If the drill shank cannot be passed freely around the rod, tighten the tie bolt (8) on the side which is binding.
13. Screw the connecting rod (53) into the upper cap (33). Insert the cotter pin (42) and tighten the locknut (45).
14. Align the pump outlet on the outlet housing (26) with the optional outlet at the base of the air motor (1). Loosely screw the tie rod locknuts (44) onto the tie rods (52). Lubricate the o-ring (47) and the top thread of the connecting rod (53). Tighten the coupling nut (50) to attach the displacement pump to the motor. Insert the cotter pin (41).
15. Start the pump and run it slowly to check for binding. Adjust the tie rods as necessary, then torque the locknuts (44) to 40–50 ft-lb (54–68 N.m).
16. Reconnect the fluid and air lines. Reconnect the ground wire if it was disconnected during service.

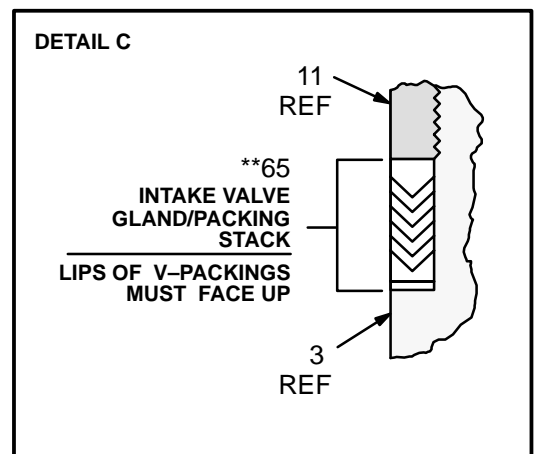
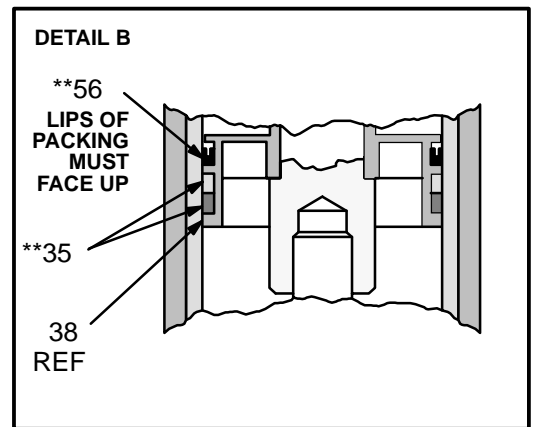
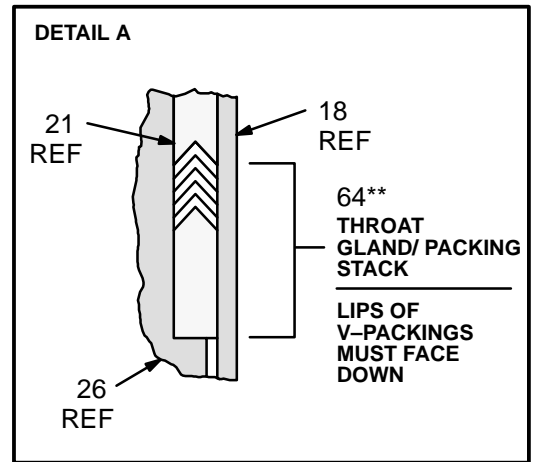
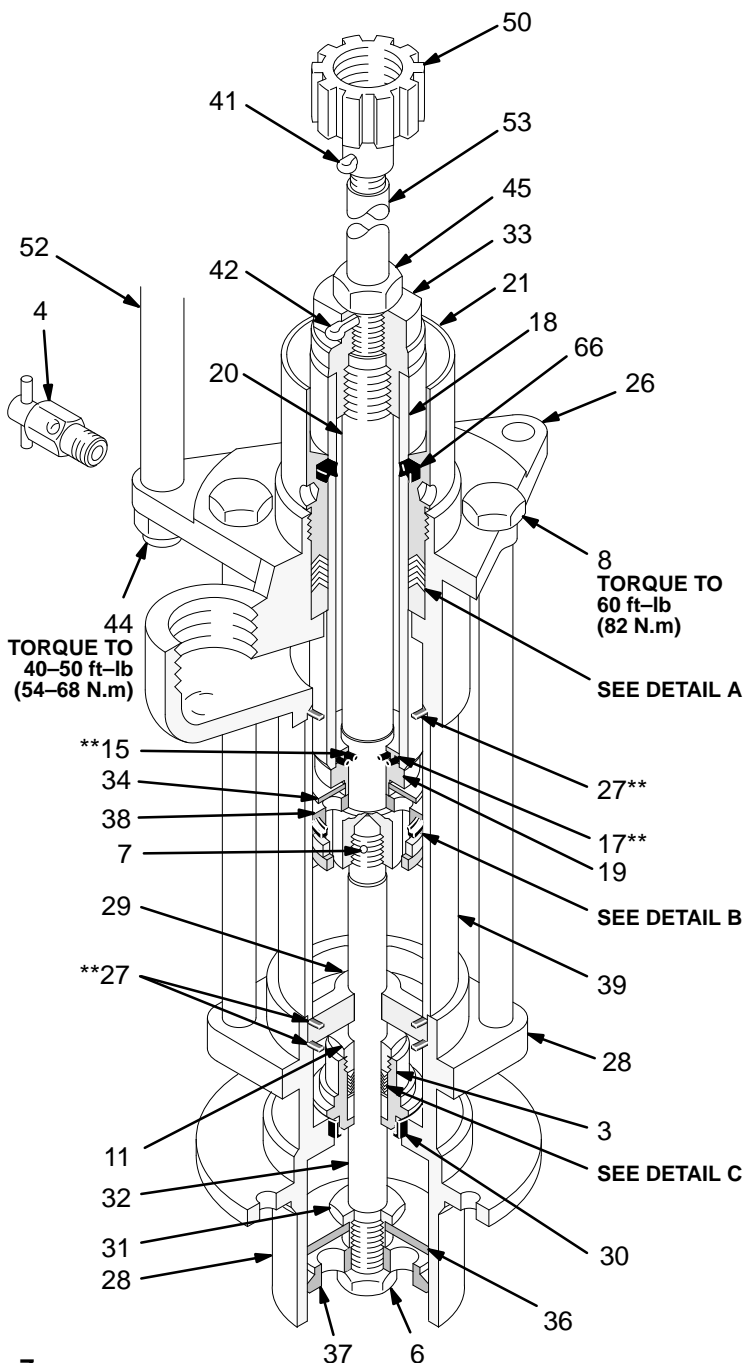
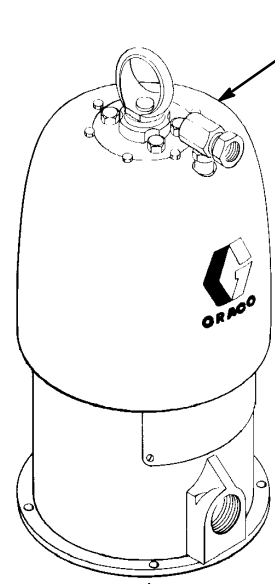

Fig 7

# PARTS DRAWING – 25:1 BULLDOG, 55:1 KING



15  
STANDARD BULLDOG  
AIR MOTOR SHOWN

## DISPLACEMENT PUMP A SHOWN

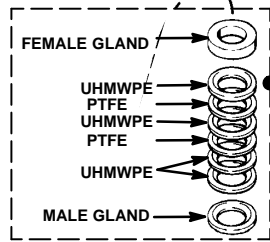

FEMALE GLAND  
UHMWPE  
PTFE  
UHMWPE  
PTFE  
UHMWPE  
MALE GLAND

159\*\*  
LIPS OF  
V-PACKINGS  
MUST FACE DOWN

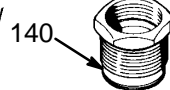

140

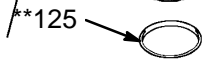

\*\*125

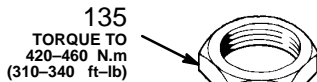

135  
TORQUE TO  
420-460 N.m  
(310-340 ft-lb)

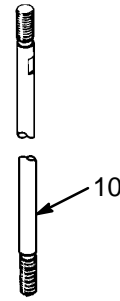

10

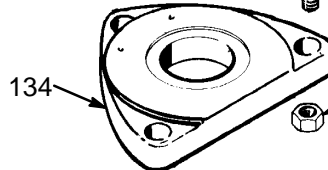

134



3

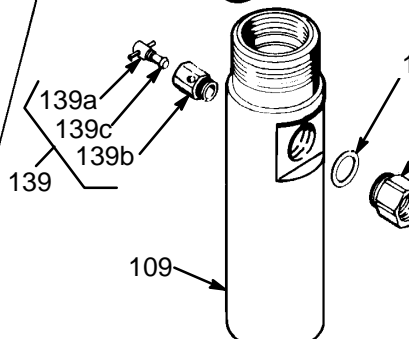

109

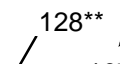

128\*\*

107  
TORQUE TO  
420-460 N.m  
(310-340 ft-lb)

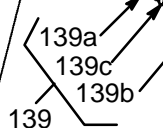

139a  
139c  
139b

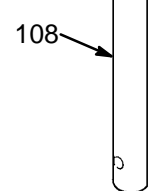

108

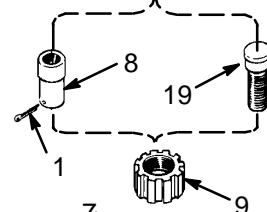

1  
7  
8  
9  
19

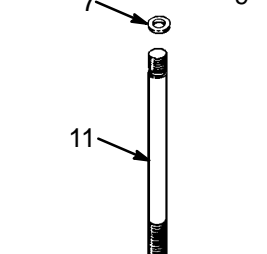

5  
11

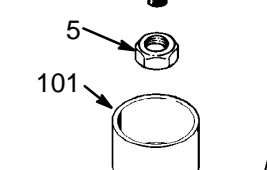

101  
\*\*102

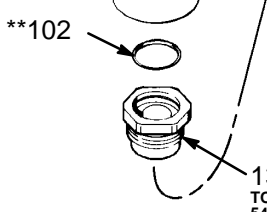

136  
TORQUE TO  
54-81 N.m  
(40-60 ft-lb)

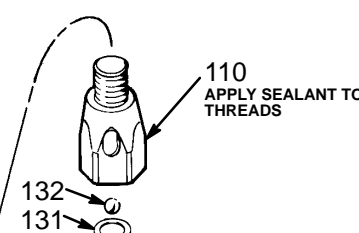

110  
APPLY SEALANT TO  
THREADS

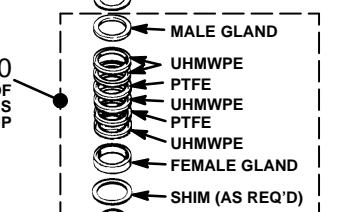

MALE GLAND  
UHMWPE  
PTFE  
UHMWPE  
PTFE  
UHMWPE  
FEMALE GLAND  
SHIM (AS REQ'D)

\*\*160  
LIPS OF  
V-PACKINGS  
MUST FACE UP

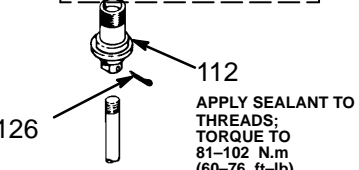

112  
APPLY SEALANT TO  
THREADS;  
TORQUE TO  
81-102 N.m  
(60-76 ft-lb)

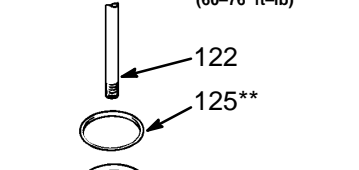

\*\*126

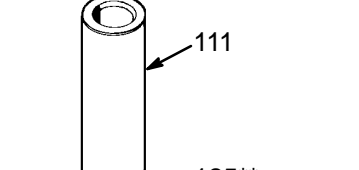

122

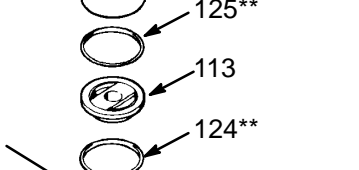

125\*\*

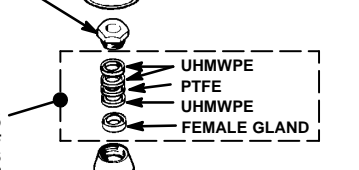

111

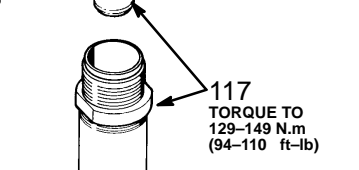

125\*\*

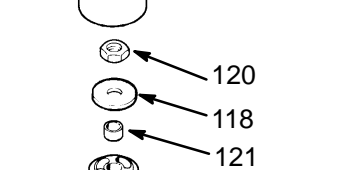

113

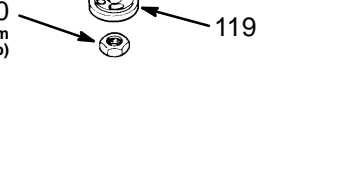

124\*\*

\*\*114  
TORQUE TO 34-47  
N.m  
(25-35 ft-lb)

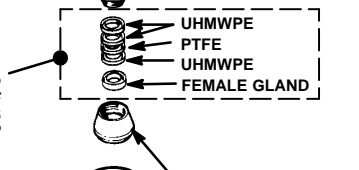

UHMWPE  
PTFE  
UHMWPE  
FEMALE GLAND

\*\*158  
LIPS OF  
V-PACKINGS  
MUST FACE UP

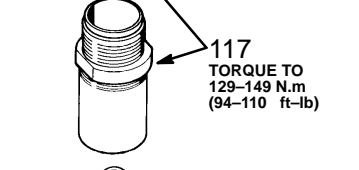

117  
TORQUE TO  
129-149 N.m  
(94-110 ft-lb)

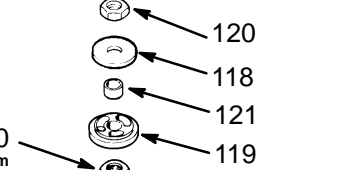

120  
118  
121

120  
TORQUE TO 54-81 N.m  
(40-60 ft-lb)



119



# PARTS LIST – 25:1 BULLDOG, 55:1 KING

## USE GENUINE GRACO PARTS AND ACCESSORIES

### BULLDOG, 35 lb. pail size

#### **25:1 Ratio Bulldog, Model 223–897**

Includes items 1–20, below.

| REF NO. | PART NO. | DESCRIPTION  | QTY |
|---------|----------|--|-----|
| 1       | 100–103  | PIN, cotter  | 1   |
| 3       | 101–712  | NUT, lock; 5/8–11; with nylon insert                               | 3   |
| 5       | 101–936  | NUT, jam hex; 3/4–10 thread  | 1   |
| 9       | 161–544  | NUT, shoulder; 1–1/4–12 thread                                     | 1   |
| 10      | 167–911  | ROD, tie; 178 mm (7") between shoulders; 5/8–11 thread             | 3   |
| 14      | PUMP A   | DISPLACEMENT PUMP;<br><i>See parts list to right</i>               | 1   |
| 15      | 208–356  | BULLDOG STANDARD AIR MOTOR;<br><i>See manual 307–049 for parts</i> | 1   |
| 19      | 166–548  | ROD, connecting; 30 mm (1.16") between holes                       | 1   |
| 20      | 176–529+ | LABEL, WARNING (not shown)   | 1   |

### BULLDOG, 400 lb. drum size

#### **25:1 Ratio Bulldog, Model 223–896**

With Standard Air Motor

Includes items 1–15, below.

### KING, 400 lb. drum size

#### **55:1 Ratio King, Model 223–898**

Includes items 1–15, below

### KING, 35 lb. pail size

#### **55:1 Ratio King, Model 224–101**

Includes items 1–15, below

| REF NO. | PART NO. | DESCRIPTION   | QTY |
|---------|----------|---|-----|
| 1       | 100–103  | PIN, cotter   | 2   |
| 3       | 101–712  | NUT, lock; 5/8–11 with nylon insert   | 3   |
| 5       | 101–936  | NUT, jam hex; 3/4–10 thread   | 1   |
| 7       | 158–674  | O–RING; buna–N  | 1   |
| 8       | 168–211  | NUT, connecting rod; 3/4–10 thread  | 1   |
| 9       | 168–210  | NUT, shoulder; 1–1/4"–12 thread   | 1   |
| 10      |          | TIE ROD   |     |
|         | 168–254  | <i>Models 223–896, 223–898</i><br>344 mm (13.56") between shoulders;<br>5/8–11 thread       | 3   |
|         | 167–911  | <i>Model 224–101 only</i><br>178 mm (7") between shoulders;<br>5/8–11 thread                |     |
| 11      | 168–253  | ROD, connecting; 171 mm (6.75") between holes   | 1   |
| 14      | PUMP A   | DISPLACEMENT PUMP;<br><i>See parts list to right</i>  | 1   |
| 15      | 208–356  | BULLDOG STANDARD AIR MOTOR;<br>Used on Model 223–896<br><i>See manual 307–049 for parts</i> | 1   |
|         | 207–647  | KING STANDARD AIR MOTOR;<br>Used on Model 223–898<br><i>See manual 306–968 for parts</i>    | 1   |

### DISPLACEMENT PUMP A

Includes items 102 to 158

| REF NO. | PART NO.  | DESCRIPTION   | QTY |
|---------|-----------|---|-----|
| 102     | 106–258** | O–RING, Viton®  | 1   |
| 107     | 178–080   | ADAPTER, outlet; M39(m)x1" npt(f)                                   | 1   |
| 108     | 178–151   | ROD, displacement   | 1   |
| 109     | 178–126   | HOUSING, pump   | 1   |
| 110     | 217–549   | HOUSING, valve, piston  | 1   |
| 111     | 178–154   | CYLINDER, pump  | 1   |
| 112     | 222–100   | VALVE, piston   | 1   |
| 113     | 178–086   | GUIDE, rod  | 1   |
| 114     | 183–755** | NUT, packing  | 1   |
| 117     | 222–637   | CYLINDER, valve, intake   | 1   |
| 118     | 178–162   | PLATE, valve, check   | 1   |
| 119     | 178–090   | PISTON, priming   | 1   |
| 120     | 106–257   | NUT, machine, hex; M16  | 2   |
| 121     | 178–109   | GUIDE, valve  | 1   |
| 122     | 178–089   | ROD, piston   | 1   |
| 124     | 106–260** | O–RING; PTFE  | 1   |
| 125     | 106–259** | O–RING; PTFE  | 3   |
| 126     | 100–103** | PIN, cotter   | 1   |
| 128     | 107–083** | O–RING; Viton®  | 1   |
| 131     | 178–163   | WASHER, back–up   | 1   |
| 132     | 106–269*  | BALL, piston  | 1   |
| 134     | 178–081   | PLATE, tie  | 1   |
| 135     | 178–079   | NUT, cylinder; M80  | 1   |
| 136     | 178–149   | NUT, packing, wet–cup   | 1   |
| 139     | 206–256   | BLEEDER VALVE ASSEMBLY;<br>includes items 139a–139c                 | 1   |
| 139a    | 102–039   | .PIN, spring  | 1   |
| 139b    | 165–702   | .BODY, bleeder valve  | 1   |
| 139c    | 165–703   | .PLUG, bleeder valve  | 1   |
| 140     | 180–394   | NUT, packing  | 1   |
| 141     | 172–477+  | TAG, instruction (not shown)  | 1   |
| 158     | **        | GLAND/PACKING STACKS<br><i>individual parts not sold separately</i> | 1   |

307 numbers refer to separate instruction manuals, supplied.

\* Recommended spare parts to keep on hand.

\*\* Supplied in repair kit 224–104.

+ Extra warning labels and tags are available at no charge.

### LEATHER PACKING REPAIR KIT 224–104

Must be purchased separately.

See doubled–starred (\*\*) parts in list above.

# PARTS DRAWING – 40:1 BULLDOG

## DISPLACEMENT PUMP B SHOWN

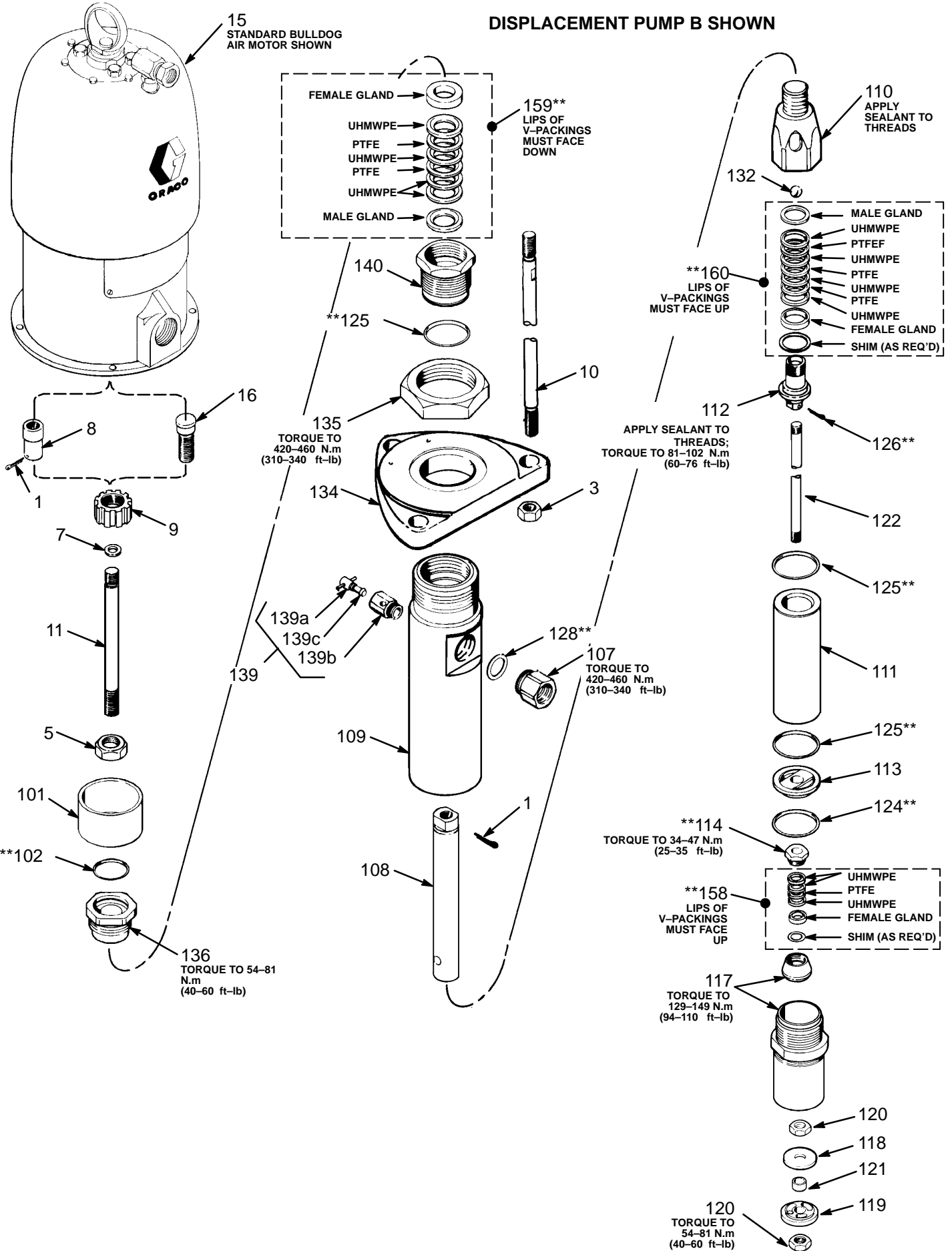

# PARTS LIST – 40:1 BULLDOG

## USE GENUINE GRACO PARTS AND ACCESSORIES

### BULLDOG, 200 liter (55 gallon) drum size

#### **40:1 Ratio Bulldog, Model 223–899**

Includes items 1–15, below

| REF NO. | PART NO. | DESCRIPTION  | QTY |
|---------|----------|--|-----|
| 1       | 100–103  | PIN, cotter  | 2   |
| 3       | 101–712  | NUT, lock; 5/8–11 with nylon insert                        | 3   |
| 5       | 101–936  | NUT, jam hex; 3/4–10 thread                                | 1   |
| 7       | 158–674  | O–RING; buna–N   | 1   |
| 8       | 168–211  | NUT, connecting rod; 3/4–10 thread                         | 1   |
| 9       | 168–210  | NUT, shoulder; 1–1/4”–12 thread                            | 1   |
| 10      | 168–254  | ROD, tie; 344 mm (13.56”) between shoulders; 5/8–11 thread | 3   |
| 11      | 168–253  | ROD, connecting; 171 mm (6.75”) between holes              | 1   |
| 14      | PUMP B   | DISPLACEMENT PUMP;<br><i>See parts list to right</i>       | 1   |
| 15      | 208–356  | AIR MOTOR<br><i>See manual 307–049 for parts</i>           | 1   |

### BULLDOG, 19 liter (5 gallon) drum size

#### **40:1 Ratio Bulldog, Model 223–900**

Includes items 1–16, below

| REF NO. | PART NO. | DESCRIPTION  | QTY |
|---------|----------|--|-----|
| 1       | 100–103  | PIN, cotter  | 1   |
| 3       | 101–712  | NUT, lock; 5/8–11; with nylon insert                   | 3   |
| 5       | 101–936  | NUT, jam hex; 3/4–10 thread                            | 1   |
| 9       | 161–544  | NUT, shoulder; 1–1/4”–12 thread                        | 1   |
| 10      | 167–911  | ROD, tie; 178 mm (7”) between shoulders; 5/8–11 thread | 3   |
| 14      | PUMP B   | DISPLACEMENT PUMP;<br><i>See parts list to right</i>   | 1   |
| 15      | 208–356  | AIR MOTOR<br><i>See manual 307–049 for parts</i>       | 1   |
| 16      | 166–548  | ROD, connecting; 30 mm (1.16”) between holes           | 1   |

### DISPLACEMENT PUMP A

Includes items 102 to 158

| REF NO. | PART NO.  | DESCRIPTION   | QTY |
|---------|-----------|---|-----|
| 102     | 106–258** | O–RING, Viton®  | 1   |
| 107     | 178–080   | ADAPTER, outlet; M39(m)x1” npt(f)                                   | 1   |
| 108     | 178–088   | ROD, displacement   | 1   |
| 109     | 178–126   | HOUSING, pump   | 1   |
| 110     | 217–550   | HOUSING, valve, piston  | 1   |
| 111     | 178–083   | CYLINDER, pump  | 1   |
| 112     | 222–032   | VALVE, piston   | 1   |
| 113     | 178–086   | GUIDE, rod  | 1   |
| 114     | 183–755** | NUT, packing  | 1   |
| 117     | 222–636   | CYLINDER, valve, intake   | 1   |
| 118     | 178–111   | PLATE, valve, check   | 1   |
| 119     | 178–091   | PISTON, priming   | 1   |
| 120     | 106–257   | NUT, machine, hex; M16  | 2   |
| 121     | 178–109   | GUIDE, valve  | 1   |
| 122     | 178–089   | ROD, piston   | 1   |
| 124     | 106–260** | O–RING; PTFE  | 1   |
| 125     | 106–259** | O–RING; PTFE  | 3   |
| 126     | 100–103** | PIN, cotter   | 1   |
| 128     | 107–083** | O–RING; Viton®  | 1   |
| 132     | 101–190*  | BALL, piston  | 1   |
| 134     | 178–081   | PLATE, tie  | 1   |
| 135     | 178–079   | NUT, cylinder; M80  | 1   |
| 136     | 178–097   | NUT, packing, wet–cup   | 1   |
| 139     | 206–256   | BLEEDER VALVE ASSEMBLY;<br>includes items 139a–139c                 | 1   |
| 139a    | 102–039   | .PIN, spring  | 1   |
| 139b    | 165–702   | .BODY, bleeder valve  | 1   |
| 139c    | 165–703   | .PLUG, bleeder valve  | 1   |
| 140     | 180–394   | NUT, packing  | 1   |
| 141     | 172–477+  | TAG, instruction (not shown)  | 1   |
| 158     | **        | GLAND/PACKING STACKS<br><i>individual parts not sold separately</i> | 1   |

307 numbers refer to separate instruction manual, supplied.

\* Recommended “tool box” spare parts. Keep on hand to reduce down time.

\*\* Supplied in repair kit 224–105.

+ Extra warning labels and tags are available at no charge.

### **LEATHER PACKING REPAIR KIT 224–105**

Must be purchased separately.

See double-starred (\*\*) items in parts lists above.

# PARTS DRAWING – 10:1 BULLDOG & 20:1 KING

## DISPLACEMENT PUMP C SHOWN

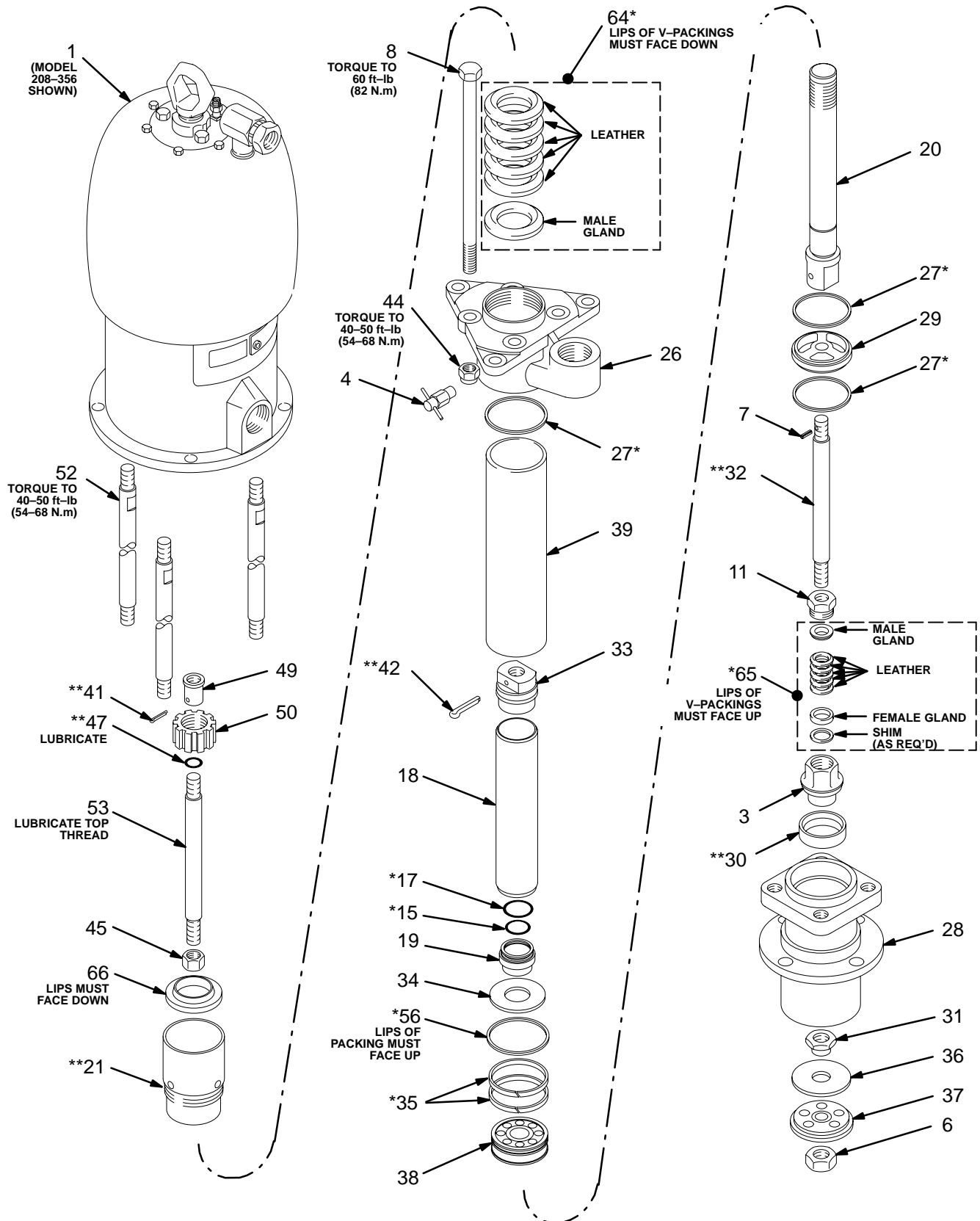

# PARTS LIST – 10:1 BULLDOG & 20:1 KING

## USE GENUINE GRACO PARTS AND ACCESSORIES

### 20:1 RATIO KING, 400 lb. drum size

#### **Model 224–103, Series A**

Includes items 1–66

### 10:1 RATIO BULLDOG, 400 lb. drum size

#### **Model 224–102, Series A**

Includes items 1–66

| REF NO. | PART NO.  | DESCRIPTION   | QTY | REF NO. | PART NO. | DESCRIPTION  | QTY |
|---------|-----------|---|-----|---------|----------|--|-----|
| 1       | 207–647   | AIR MOTOR<br>KING <i>Model 224–103 only</i><br><i>See manual 306–968 for parts</i>                | 1   | 41      | 100–103* | PIN, cotter; 0.125" (3.2 mm) dia. x 1.5" (38 mm) long      | 1   |
|         | 208–356   | BULLDOG <i>Model 224–102 only</i><br><i>See manual 307–049 for parts</i>                          | 1   | 42      | 100–104* | PIN, cotter; 0.125" (3.2 mm) dia. x 1.75" (45 mm) long     | 1   |
| 2       | PUMP C    | DISPLACEMENT PUMP ASSEMBLY<br>Includes items 3–39   | 1   | 44      | 101–712  | NUT, lock; 5/8–11; w/nylon insert                          | 3   |
| 3       | 205–161   | .HOUSING, intake valve seal<br>Includes item 30   | 1   | 45      | 101–936  | NUT, hex, jam; 3/4"  | 1   |
| 4       | 206–256   | .VALVE, bleeder   | 1   | 47      | 158–674* | O–RING, nitrile rubber                                     | 1   |
| 5       | 108–543** | .PACKING, u–cup; UHMWPE   | 1   | 49      |          | COUPLING, connecting rod                                   | 1   |
| 6       | 100–155   | .NUT, hex, jam; 5/8–18  | 1   |         | 168–211  | <i>Model 224–103 only</i>                                  | 1   |
| 7       | 101–354   | .PIN, roll; 0.188" (4.8 mm) dia;<br>1.125" (28.6 mm) long   | 1   |         | 161–543  | <i>Model 224–102 only</i>                                  | 1   |
| 8       | 102–420   | .BOLT, hex hd cap; 5/8–11 x 12"   | 4   | 50      |          | NUT, shouldered  | 1   |
| 9       | 172–477†  | .TAG, warning (not shown)   | 1   |         | 168–210  | <i>Model 224–103 only</i>                                  | 1   |
| 11      | 158–440   | .NUT, packing, intake valve   | 1   |         | 161–544  | <i>Model 224–102 only</i>                                  | 1   |
| 12      | **        | .GLAND/PACKING STACKS<br>(throat and intake valve)<br><i>individual parts not sold separately</i> | 1   | 52      | 168–824  | ROD, tie; 13–7/8" (352.4 mm) long,<br>shoulder to shoulder | 3   |
| 13      | 110–769   | .SEAL, wiper; polyurethane  | 1   | 53      |          | ROD, connecting  | 1   |
| 15      | 108–833** | .O–RING, Viton®   | 1   |         | 168–253  | 9–5/16" (236.5 mm)   | 1   |
| 17      | 108–832** | .O–RING, Viton  | 1   |         | 164–443  | <i>Model 224–103 only</i>                                  | 1   |
| 18      | 162–887   | .ROD, displacement  | 1   |         |          | <i>Model 224–102 only</i>                                  | 1   |
| 19      | 162–888   | .CAP, lower   | 1   |         |          |  |     |
| 20      | 162–891   | .ROD, connecting  | 1   |         |          |  |     |
| 21      | 186–058*  | .PACKING NUT/WET–CUP  | 1   |         |          |  |     |
| 26      | 181–896   | .HOUSING, outlet  | 1   |         |          |  |     |
| 27      | 162–898** | .GASKET, copper   | 3   |         |          |  |     |
| 28      | 162–900   | .HOUSING, intake valve  | 1   |         |          |  |     |
| 29      | 162–901   | .STOP, intake valve   | 1   |         |          |  |     |
| 30      | 162–902*  | .SEAT, intake valve (part of item 3)  | 1   |         |          |  |     |
| 31      | 162–903   | .GUIDE, valve plate   | 1   |         |          |  |     |
| 32      | 162–906*  | .ROD, priming   | 1   |         |          |  |     |
| 33      | 164–442   | .CAP, upper   | 1   |         |          |  |     |
| 34      | 165–888   | .PLATE, valve   | 1   |         |          |  |     |
| 35      | 181–897** | .BEARING, piston  | 2   |         |          |  |     |
| 36      | 165–890   | .PLATE, valve   | 1   |         |          |  |     |
| 37      | 172–199   | .PISTON, priming  | 1   |         |          |  |     |
| 38      | 181–893   | .PISTON, cylinder   | 1   |         |          |  |     |
| 39      | 180–936   | .CYLINDER, pump   | 1   |         |          |  |     |

\*Included in repair kit 220–861.

\*\*Recommended "tool box" spare parts. Keep on hand to reduce down time.

† Extra warning labels and tags are available free.

306 and 307 numbers in descriptions refer to separate instruction manuals, supplied.

#### **LEATHER PUMP REPAIR KIT 224–147**

*Must be purchased separately*

Includes all double-starred (\*\*) items in parts list above.

## ACCESSORIES

Must be purchased separately.

### USE GENUINE GRACO PARTS AND ACCESSORIES

**GROUNDING CLAMP** 103-538  
**GROUND WIRE** 208-950  
 7.6 m (25 ft) long,  
 1.5 mm<sup>2</sup> (12 gauge)

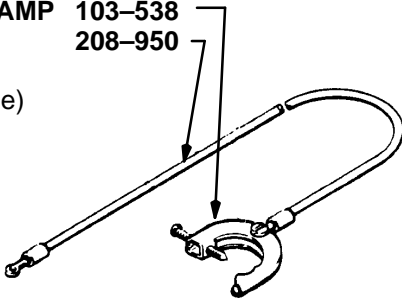

**BLEED-TYPE MASTER AIR VALVE 107-141**  
 21 bar (300 psi) **MAXIMUM WORKING PRESSURE**  
 3/4 npt(m x f) inlet and outlet

Relieves air trapped in the air line between the pump air inlet and this valve when closed.

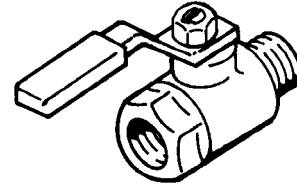

**AIR PRESSURE REGULATOR KIT**  
 14 bar (200 psi) **MAXIMUM WORKING PRESSURE**  
 Includes bleed-type master air valve

**205-712** For Bulldog pumps  
**207-651** For King pumps

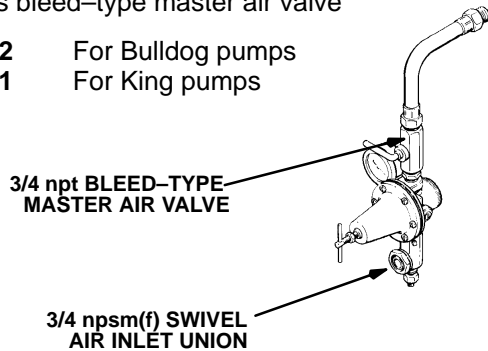

**PUMP RUNAWAY VALVE 215-362**  
 12 bar (180 psi) **MAXIMUM WORKING PRESSURE**  
 Shuts off air supply to the pump if the pump accelerates beyond the pre-adjusted setting due to an empty supply container, interrupted fluid supply to the pump, or excessive cavitation. 3/4 npt(f).

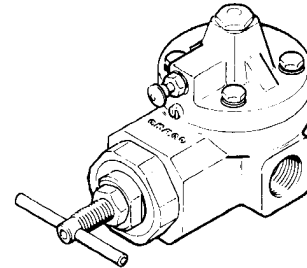

**AIR LINE FILTER 106-150**  
 17.5 bar (250 psi) **MAXIMUM WORKING PRESSURE**  
 3/4 npt inlet and outlet

**AIR LINE LUBRICATOR 214-849**  
 17.5 bar (250 psi) **MAXIMUM WORKING PRESSURE**  
 3/4 npt inlet and outlet

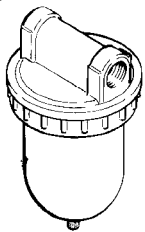

FILTER 106-150

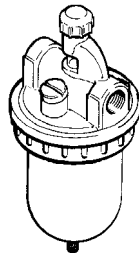

LUBRICATOR 214-849

**FLUID DRAIN VALVE 210-658**  
 350 bar (5000 psi) **MAXIMUM WORKING PRESSURE**  
 3/8 npt (mbe); Viton seals

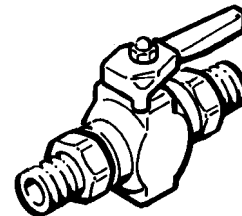

ACCESSORIES CONTINUED ON THE NEXT PAGE

## ACCESSORIES

*Must be purchased separately.*

### USE GENUINE GRACO PARTS AND ACCESSORIES

#### FLOOR STAND

Provides secure floor mounting for pump when used with bulk grease containers. 3" npt fluid inlet. Order the following parts.

- 223-952** Floor Stand
- 208-390** Ball Valve
- 110-301** Gasket
- 102-637** Capscrew (order 4)

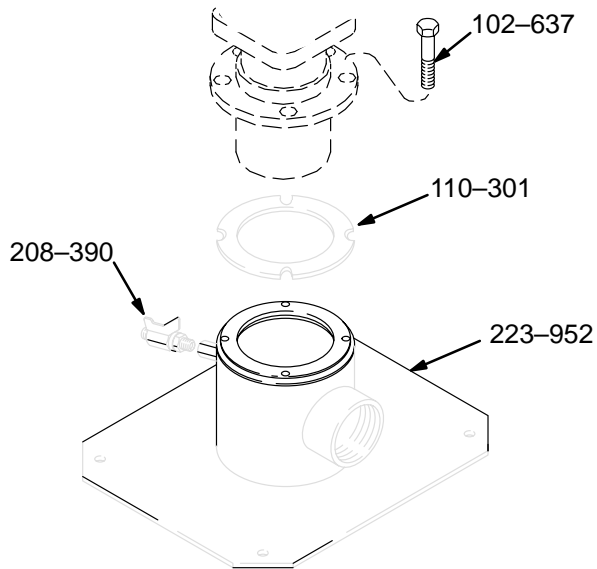

#### 400 lb. DRUM RAM 207-279

For extruding highly viscous fluids from open 400 lb. drums. See manual 308-066 for complete Ram units using the pumps covered in this manual.

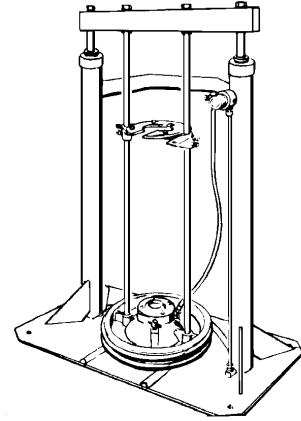

**MODEL 207-279**

#### INDUCTOR PLATE 206-747

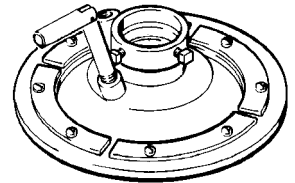

*ACCESSORIES CONTINUED ON THE NEXT PAGE*

## ACCESSORIES

*Must be purchased separately.*

### USE GENUINE GRACO PARTS AND ACCESSORIES

#### GROUNDING BUNA-N AIR SUPPLY HOSE

*175 psi (12 bar) MAXIMUM WORKING PRESSURE*

| Part No. | ID           | Length         | Thd. Size  |
|----------|--------------|----------------|------------|
| 208-610  | 3/4" (19 mm) | 6 ft (1.8 m)   | 3/4 npt(m) |
| 205-548  | 3/4" (19 mm) | 15 ft (4.6 m)  | 3/4 npt(m) |
| 208-611  | 3/4" (19 mm) | 25 ft (7.6 m)  | 3/4 npt(m) |
| 208-612  | 3/4" (19 mm) | 50 ft (15.2 m) | 3/4 npt(m) |

#### GROUNDING BUNA-N FLUID HOSE

*3500 psi (240 bar) MAXIMUM WORKING PRESSURE*

| Part No. | ID             | Length         | Thd. Size  |
|----------|----------------|----------------|------------|
| 214-962  | 1/2" (12.7 mm) | 15 ft (4.6 m)  | 1/2 npt(m) |
| 214-963  | 1/2" (12.7 mm) | 25 ft (7.6 m)  | 1/2 npt(m) |
| 214-964  | 1/2" (12.7 mm) | 50 ft (15.2 m) | 1/2 npt(m) |

#### GROUNDING NYLON FLUID HOSE

*3000 psi (210 bar) MAXIMUM WORKING PRESSURE*

| Part No. | ID             | Length                         | Thd. Size                                |
|----------|----------------|--------------------------------|--|
| 214-700  | 3/16" (4.8 mm) | 2 ft (610 mm)<br>(fbc) swivel  | 1/4 npsm                                 |
| 214-701  | 3/16" (4.8 mm) | 3 ft (914 mm)                  | 1/4 npt(m)<br>x 1/4<br>npsm(f)<br>swivel |
| 210-540  | 1/4" (6.4 mm)  | 25 ft (7.6 m)                  | 1/4 npsm<br>(fbc) swivel                 |
| 210-541  | 1/4" (6.4 mm)  | 50 ft (15.2 m)<br>(fbc) swivel | 1/4 npsm                                 |
| 214-703  | 3/8" (9.5 mm)  | 25 ft (7.6 m)                  | 3/8 npt<br>(mbe)                         |
| 214-705  | 3/8" (9.5 mm)  | 50 ft (15.2 m)                 | 3/8 npt<br>(mbe)                         |
| 214-920  | 3/8" (9.5 mm)  | 100 ft (30.4 m)                | 3/8 npt<br>(mbe)                         |

#### GROUNDING BUNA-N FLUID HOSE

*5000 psi (345 bar) MAXIMUM WORKING PRESSURE*

| Part No. | ID             | Length         | Thd. Size        |
|----------|----------------|----------------|------------------|
| 215-445  | 1/2" (12.7 mm) | 5 ft (1.5 m)   | 1/2 npt<br>(mbe) |
| 215-441  | 1/2" (12.7 mm) | 10 ft (3.1 m)  | 1/2 npt<br>(mbe) |
| 215-443  | 1/2" (12.7 mm) | 25 ft (7.6 m)  | 1/2 npt<br>(mbe) |
| 215-444  | 1/2" (12.7 mm) | 50 ft (15.2 m) | 1/2 npt<br>(mbe) |

#### GROUNDING NEOPRENE FLUID HOSE

*5000 psi (345 bar) MAXIMUM WORKING PRESSURE*

| Part No. | ID             | Length        | Thd. Size        |
|----------|----------------|---------------|------------------|
| 215-241  | 3/4" (19.1 mm) | 6 ft (1.8 m)  | 3/4 npt<br>(mbe) |
| 215-238  | 3/4" (19.1 mm) | 10 ft (3.1 m) | 3/4 npt<br>(mbe) |
| 215-239  | 3/4" (19.1 mm) | 15 ft (4.6 m) | 3/4 npt<br>(mbe) |
| 215-240  | 3/4" (19.1 mm) | 25 ft (7.6 m) | 3/4 npt<br>(mbe) |



## TECHNICAL DATA – 10:1 RATIO BULLDOG

|  |   |
|--|---|
| Maximum working pressure .....         | 70 bar (1000 psi)   |
| Air operating range .....              | 2.8–7 bar (40–100 psi)  |
| Air inlet size .....                   | 3/4 npt(f)  |
| Flow Capability* (grease at 8 lbs/gal) |   |
| Free Flow (intermediate) .....         | 45 kg/min (100 lbs/min)   |
| 60 cycles/min (continuous) .....       | 22.67 kg/min (50 lbs/min)   |
| Fluid outlet size .....                | 1 1/2" npt(f)   |
| Wetted parts .....                     | Zinc-plated Carbon Steel, Nitralloy Steel,<br>Polyethylene, Viton®, Polyurethane, Leather |
| Stroke length .....                    | 120 mm (4.75")  |
| Air Motor Effective Diameter .....     | 17.73 cm (7")   |

\*Flow will vary with the viscosity of the material being pumped.

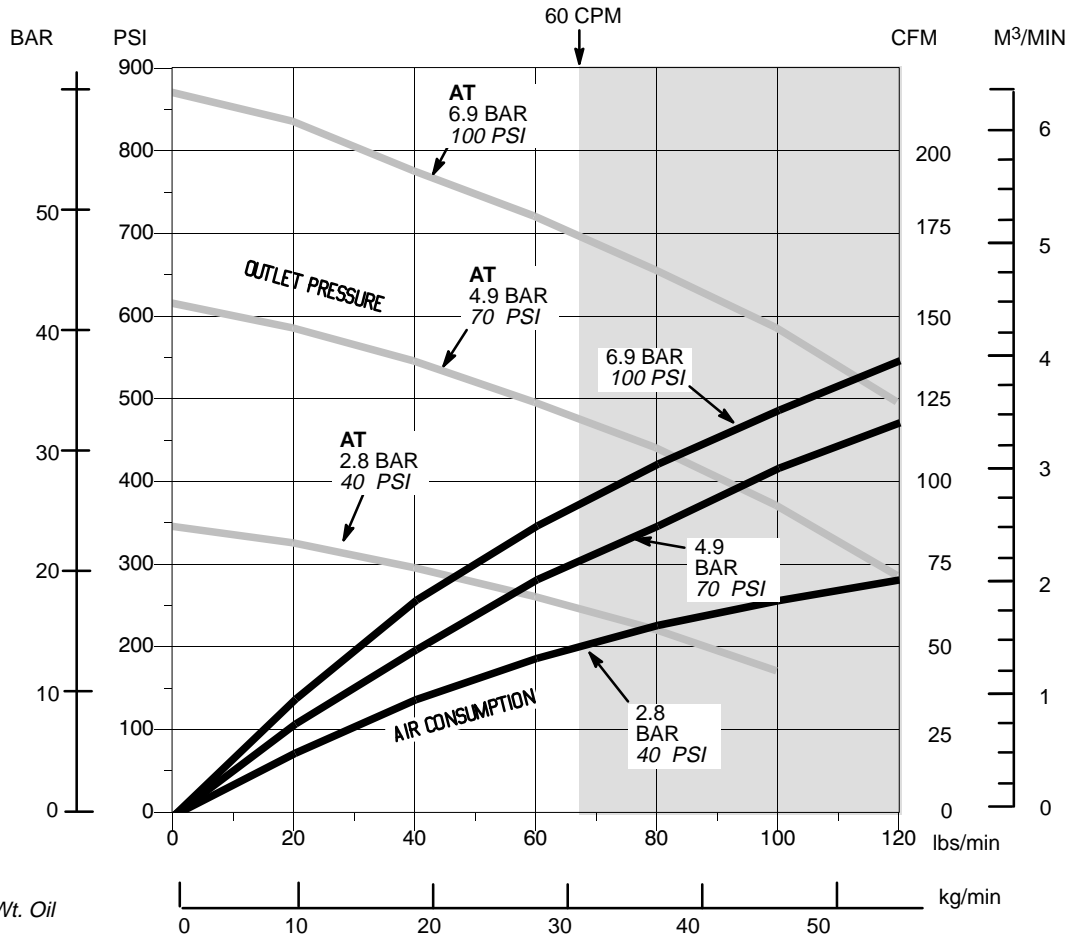

Tested in 10 Wt. Oil

### PUMP PERFORMANCE CHART

**To find Outlet Pressure** (bar–psi) at a specific delivery (lbs/min – kg/min) and operating air pressure (bar–psi):

1. Locate desired delivery along bottom of chart.
2. Read vertical line up to intersection with selected fluid outlet pressure curve. Curve slopes from left to right. Follow left to scale and read outlet pressure.

**To find Pump Air Consumption** (m3/min–CFM) specific delivery (lbs/min – kg/min) and operating air pressure (bar–psi):

1. Locate desired delivery along bottom of chart.
2. Read vertical line up to intersection with selected air consumption curve. Curve slopes from right to left. Follow right to scale and read air consumption. Follow left to scale and read outlet pressure.

## TECHNICAL DATA – 25:1 RATIO BULLDOG

|  |   |
|--|---|
| Maximum working pressure               | 175 bar (2500 psi)  |
| Air operating range                    | 2.8–7 bar (40–100 psi)  |
| Air inlet size                         | 3/4 npt(f)  |
| Flow Capability* (grease at 8 lbs/gal) |   |
| Free Flow (intermediate)               | 25 kg/min (55 lbs/min)  |
| 60 cycles/min (continuous)             | 12.7 kg/min (28 lbs/min)  |
| Fluid outlet size                      | 1" npt(f)   |
| Wetted parts                           | Zinc-plated Carbon Steel, Nitralloy Steel,<br>PTFE, Viton®, Bronze, Polyurethane, Leather |
| Stroke length                          | 120 mm (4.75")  |
| Air Motor Effective Diameter           | 17.73 cm (7")   |

\*Flow will vary with the viscosity of the material being pumped.

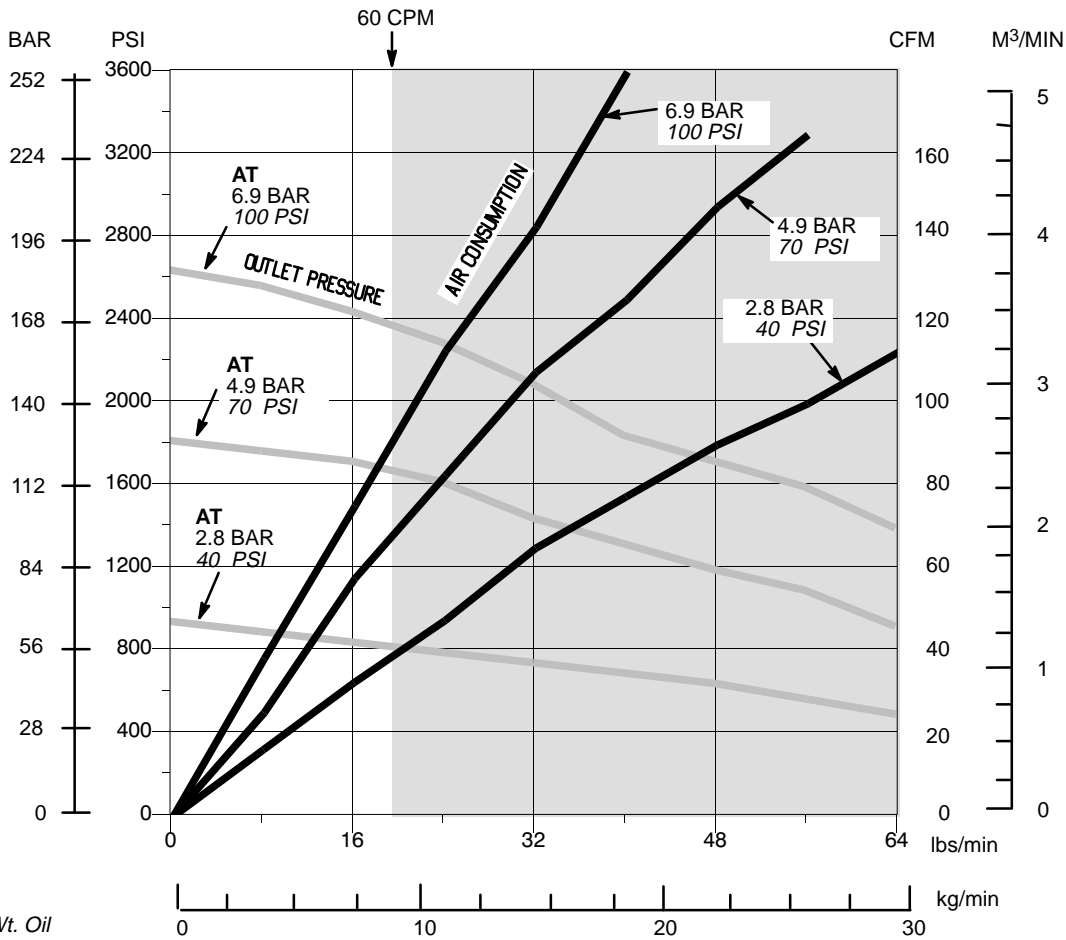

Tested in 10 Wt. Oil

### PUMP PERFORMANCE CHART

**To find Outlet Pressure (bar–psi) at a specific delivery (lbs/min – kg/min) and operating air pressure (bar–psi):**

1. Locate desired delivery along bottom of chart.
2. Read vertical line up to intersection with selected fluid outlet pressure curve. Curve slopes from left to right. Follow left to scale and read outlet pressure.

**To find Pump Air Consumption (m3/min–CFM) specific delivery (lbs/min – kg/min) and operating air pressure (bar–psi):**

1. Locate desired delivery along bottom of chart.
2. Read vertical line up to intersection with selected air consumption curve. Curve slopes from right to left. Follow right to scale and read air consumption. Follow left to scale and read outlet pressure.

## TECHNICAL DATA - 40:1 RATIO BULLDOG

|  |   |
|--|---|
| Maximum working pressure .....         | 280 bar (4000 psi)  |
| Air operating range .....              | 2.8–7 bar (40–100 psi)  |
| Flow Capability* (grease at 8 lbs/gal) |   |
| Free Flow (intermediate) .....         | 14.5 kg/min (32 lbs/min)  |
| 60 cycles/min (continuous) .....       | 7.25 kg/min (16 lbs/min)  |
| Air inlet size .....                   | 3/4 npsm(f)   |
| Fluid outlet size .....                | 1" npt(f)   |
| Wetted parts .....                     | Zinc-plated Carbon Steel, Nitralloy Steel,<br>PTFE, Viton®, Polyurethane, Leather |
| Stroke length .....                    | 120 mm (4.75")  |
| Air Motor Effective Diameter .....     | 17.73 cm (7")   |

\*Flow will vary with the viscosity of the material being pumped.

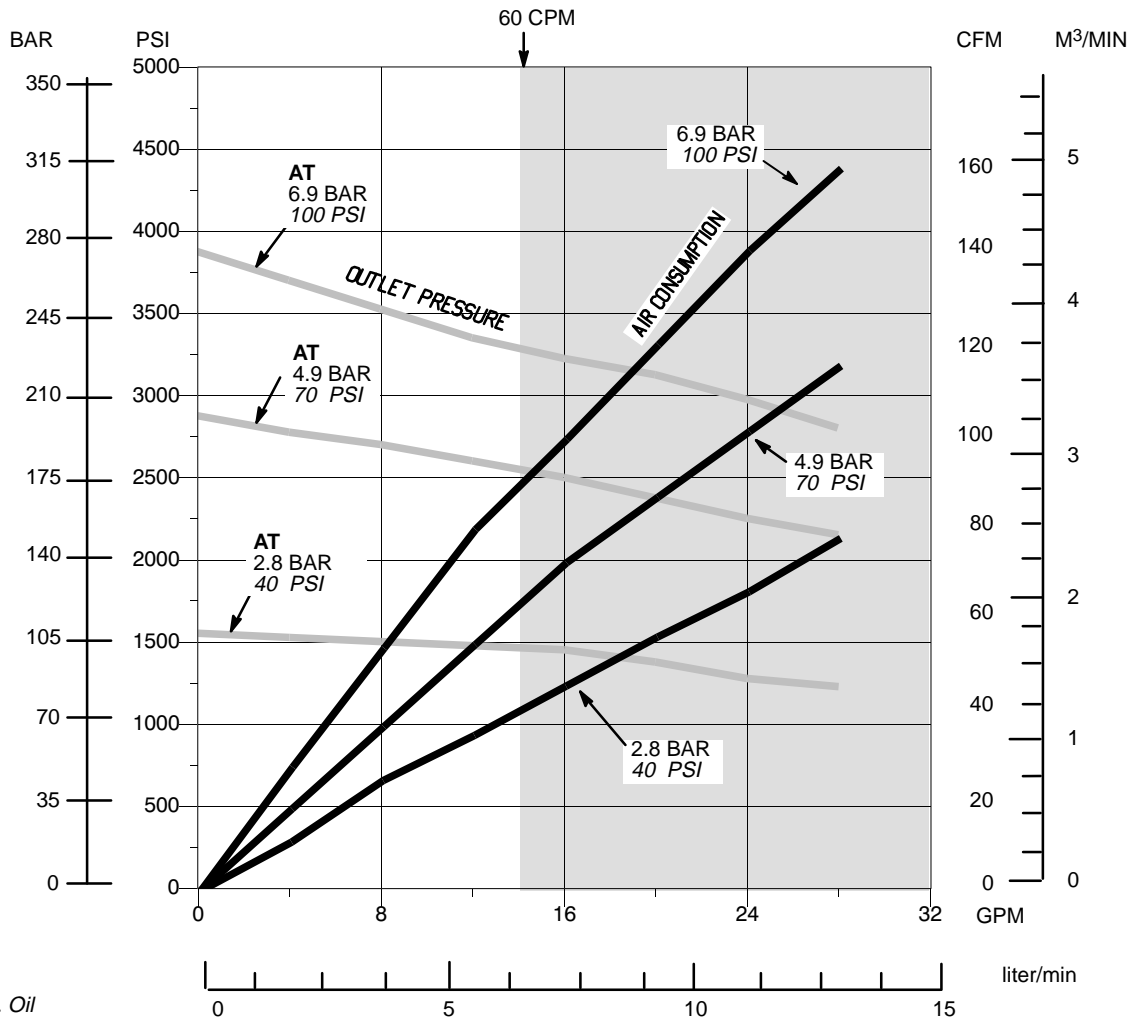

Tested in 10 Wt. Oil

### PUMP PERFORMANCE CHART

**To find Outlet Pressure** (bar–psi) at a specific delivery (lbs/min – kg/min) and operating air pressure (bar–psi):

1. Locate desired delivery along bottom of chart.
2. Read vertical line up to intersection with selected fluid outlet pressure curve. Curve slopes from left to right. Follow left to scale and read outlet pressure.

**To find Pump Air Consumption** (m3/min–CFM) specific delivery (lbs/min – kg/min) and operating air pressure (bar–psi):

1. Locate desired delivery along bottom of chart.
2. Read vertical line up to intersection with selected air consumption curve. Curve slopes from right to left. Follow right to scale and read air consumption. Follow left to scale and read outlet pressure.

## TECHNICAL DATA - 20:1 RATIO KING

|  |   |
|--|---|
| Maximum working pressure               | 122 bar (1800 psi)  |
| Air operating range                    | 2.8–6.2 bar (40 – 90 psi)   |
| Flow Capability* (grease at 8 lbs/gal) |   |
| Free Flow (intermediate)               | 45 kg/min (100 lbs/min)   |
| 60 cycles/min (continuous)             | 22.67 kg/min (50 lbs/min)   |
| Air inlet size                         | 3/4 npsm(f)   |
| Fluid outlet size                      | 1 1/2" npt(f)   |
| Wetted parts                           | Zinc-plated Carbon Steel, Nitralloy Steel,<br>PTFE, Viton®, Polyurethane, Leather |
| Stroke length                          | 120 mm (4.75")  |
| Air Motor Effective Diameter           | 25.4 cm (10")   |

\*Flow will vary with the viscosity of the material being pumped.

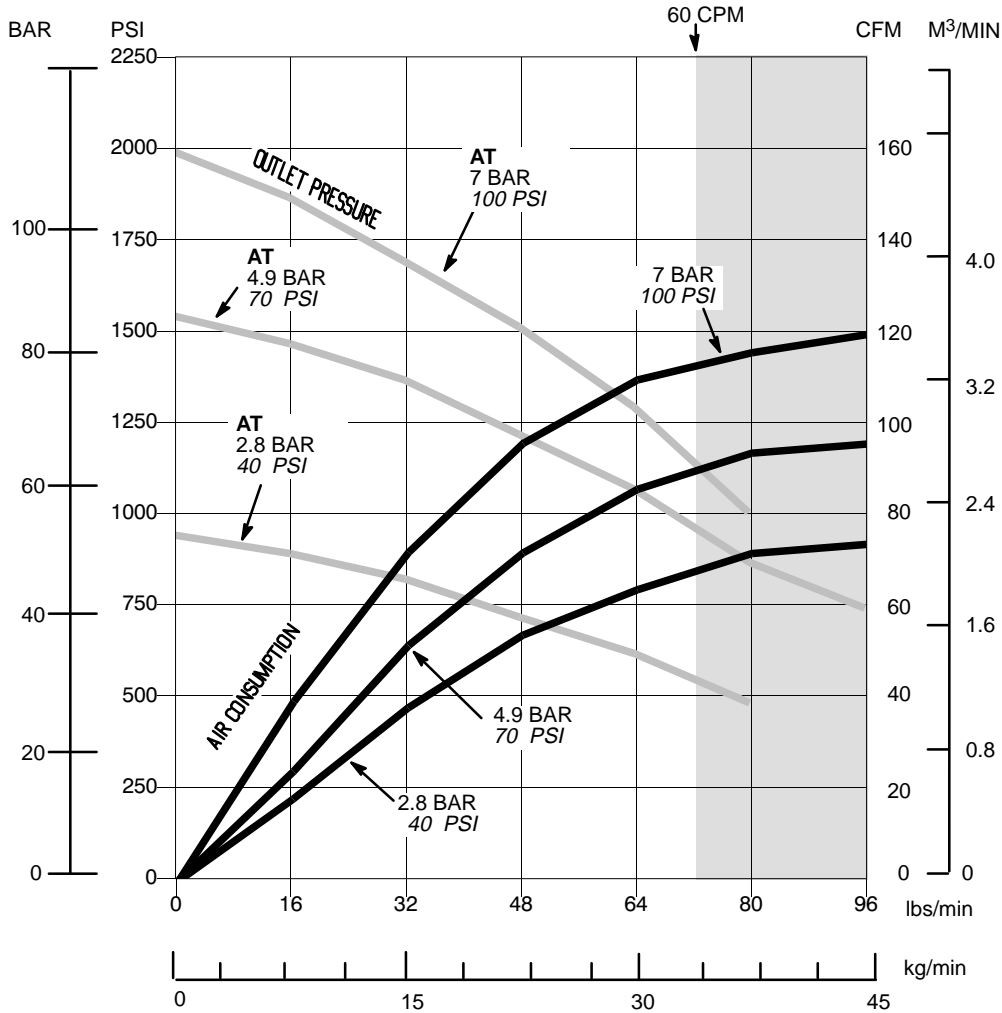

Tested in 10 Wt. Oil

### PUMP PERFORMANCE CHART

**To find Outlet Pressure (bar–psi) at a specific delivery (lbs/min – kg/min) and operating air pressure (bar–psi):**

1. Locate desired delivery along bottom of chart.
2. Read vertical line up to intersection with selected fluid outlet pressure curve. Curve slopes from left to right. Follow left to scale and read outlet pressure.

**To find Pump Air Consumption (m<sup>3</sup>/min–CFM) specific delivery (lbs/min – kg/min) and operating air pressure (bar–psi):**

1. Locate desired delivery along bottom of chart.
2. Read vertical line up to intersection with selected air consumption curve. Curve slopes from right to left. Follow right to scale and read air consumption. Follow left to scale and read outlet pressure.

## TECHNICAL DATA - 55:1 RATIO KING

|  |   |
|--|---|
| Maximum working pressure .....         | 345 bar (5000 psi)  |
| Air operating range .....              | 2.8–6.2 bar (40 – 90 psi)   |
| Flow Capability* (grease at 8 lbs/gal) |   |
| Free Flow (intermediate) .....         | 25 kg/min (55 lbs/min)  |
| 60 cycles/min (continuous) .....       | 12.7 kg/min (28 lbs/min)  |
| Air inlet size .....                   | 3/4 npsm(f)   |
| Fluid outlet size .....                | 1" npt(f)   |
| Wetted parts .....                     | Zinc-plated Carbon Steel, Nitralloy Steel,<br>Bronze, Polyurethane, Leather |
| Stroke length .....                    | 120 mm (4.75")  |
| Air Motor Effective Diameter .....     | 25.4 cm (10")   |

\*Flow will vary with the viscosity of the material being pumped.

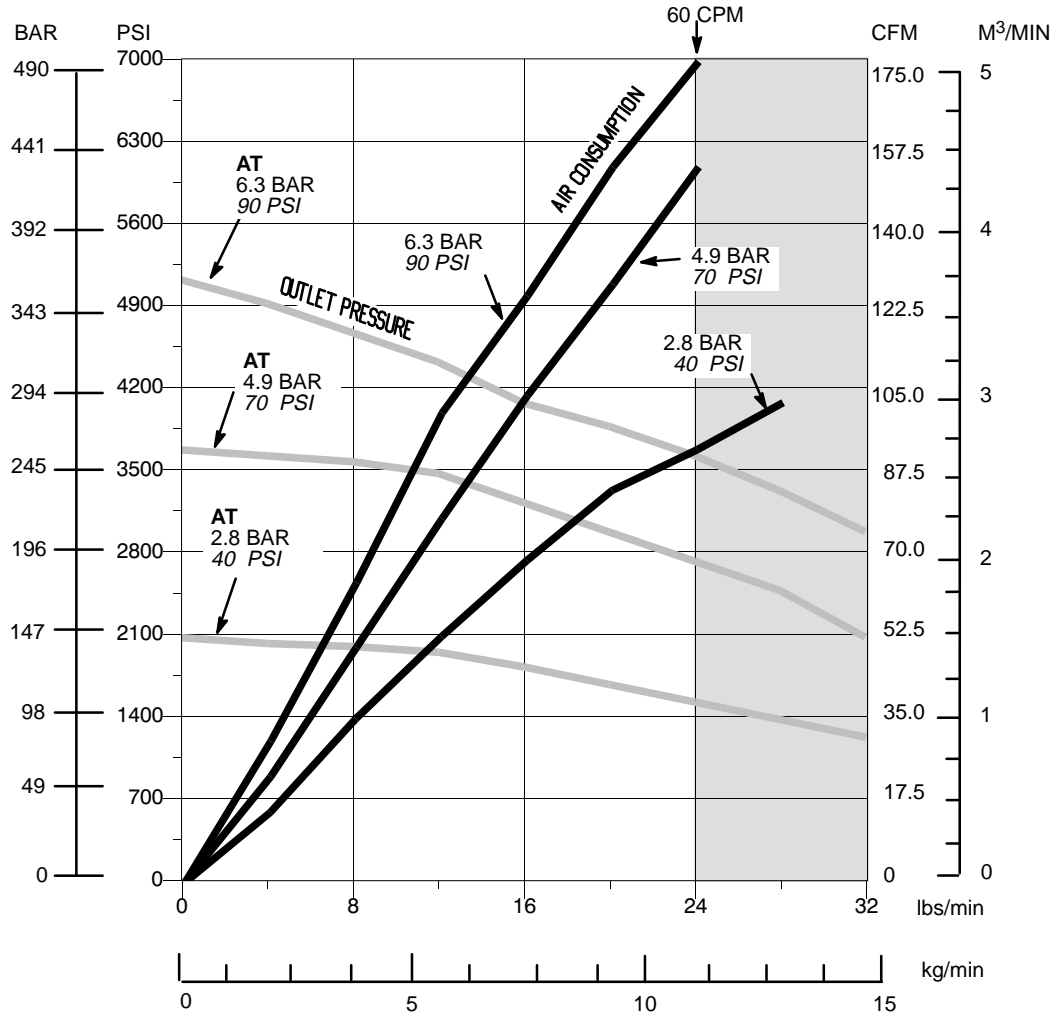

Tested in 10 Wt. Oil

### PUMP PERFORMANCE CHART

**To find Outlet Pressure** (bar–psi) at a specific delivery (lbs/min – kg/min) and operating air pressure (bar–psi):

1. Locate desired delivery along bottom of chart.
2. Read vertical line up to intersection with selected fluid outlet pressure curve. Curve slopes from left to right. Follow left to scale and read outlet pressure.

**To find Pump Air Consumption** (m<sup>3</sup>/min–CFM) specific delivery (lbs/min – kg/min) and operating air pressure (bar–psi):

1. Locate desired delivery along bottom of chart.
2. Read vertical line up to intersection with selected air consumption curve. Curve slopes from right to left. Follow right to scale and read air consumption. Follow left to scale and read outlet pressure.

# DIMENSIONS

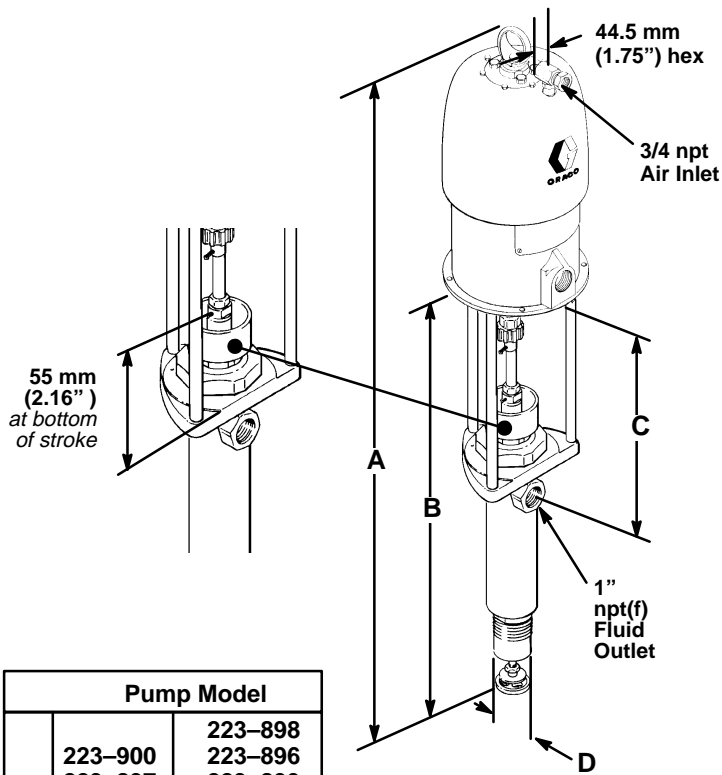

| Pump Model |                                    |
|------------|------------------------------------|
|            | 223-900<br>223-897                 |
|            | 223-898<br>223-896<br>223-899      |
| A          | 1194 mm (47")<br>1365 mm (53.75")  |
| B          | 654 mm (25.75")<br>826 mm (32.5")  |
| C          | 236 mm (9.3")<br>403 mm (15.85")   |
| D          | 68.2 mm (2.69")<br>68.2 mm (2.69") |

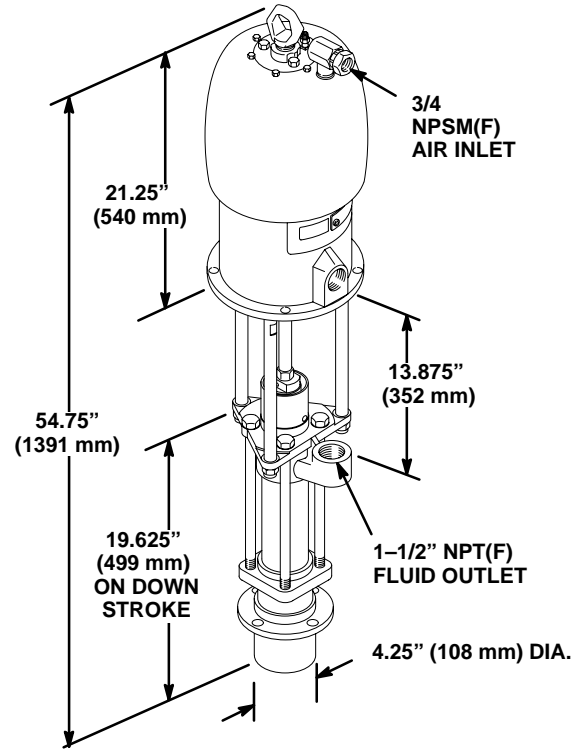

Models 224-102 and 224-103

# MOUNTING DIAGRAM

Models 223-896, 223-897, 223-898,  
223-899, 223-900

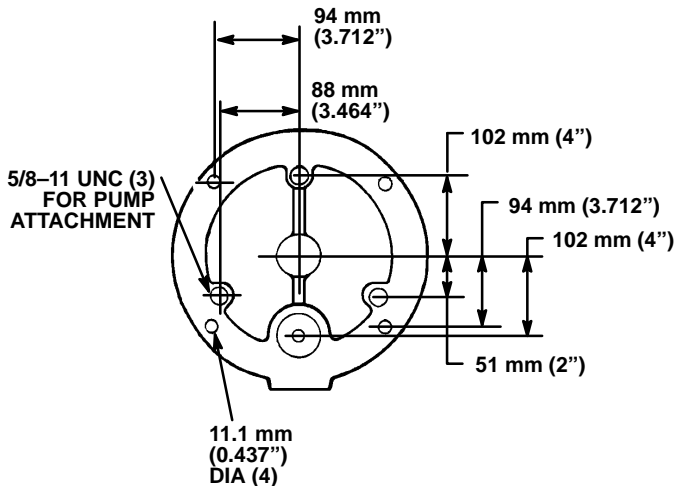

Models 224-102 and 224-103

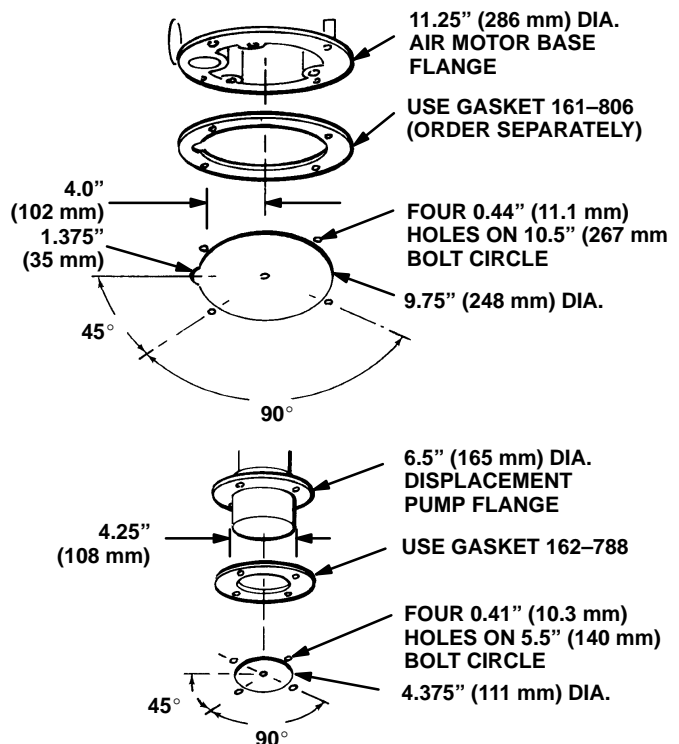



# THE GRACO WARRANTY AND DISCLAIMERS

## WARRANTY

Graco warrants all equipment manufactured by it and bearing its name to be free from defects in material and workmanship on the date of sale by an authorized Graco distributor to the original purchaser for use. As purchaser's sole remedy for breach of this warranty, Graco will, for a period of twelve months from the date of sale, repair or replace any part of the equipment proven defective. This warranty applies only when the equipment is installed, operated and maintained in accordance with Graco's written recommendations.

This warranty does not cover, and Graco shall not be liable for, any malfunction, damage or wear caused by faulty installation, misapplication, abrasion, corrosion, inadequate or improper maintenance, negligence, accident, tampering, or substitution of non-Graco component parts. Nor shall Graco be liable for malfunction, damage or wear caused by the incompatibility with Graco equipment of structures, accessories, equipment or materials not supplied by Graco, or the improper design, manufacture, installation, operation or maintenance of structures, accessories, equipment or materials not supplied by Graco.

This warranty is conditioned upon the prepaid return of the equipment claimed to be defective to an authorized Graco distributor for verification of the claim. If the claimed defect is verified, Graco will repair or replace free of charge any defective parts. The equipment will be returned to the original purchaser transportation prepaid. If inspection of the equipment does not disclose any defect in material or workmanship, repairs will be made at a reasonable charge, which charges may include the costs of parts, labor and transportation.

## DISCLAIMERS AND LIMITATIONS

THE TERMS OF THIS WARRANTY CONSTITUTE PURCHASER'S SOLE AND EXCLUSIVE REMEDY AND ARE IN LIEU OF ANY OTHER WARRANTIES (EXPRESS OR IMPLIED), INCLUDING WARRANTY OF MERCHANTABILITY OR WARRANTY OF FITNESS FOR A PARTICULAR PURPOSE, AND OF ANY NON-CONTRACTUAL LIABILITIES, INCLUDING PRODUCT LIABILITIES, BASED ON NEGLIGENCE OR STRICT LIABILITY. EVERY FORM OF LIABILITY FOR DIRECT, SPECIAL OR CONSEQUENTIAL DAMAGES OR LOSS IS EXPRESSLY EXCLUDED AND DENIED. IN NO CASE SHALL GRACO'S LIABILITY EXCEED THE AMOUNT OF THE PURCHASE PRICE. ANY ACTION FOR BREACH OF WARRANTY MUST BE BROUGHT WITHIN TWO (2) YEARS OF THE DATE OF SALE.

## EQUIPMENT NOT COVERED BY GRACO WARRANTY

GRACO MAKES NO WARRANTY, AND DISCLAIMS ALL IMPLIED WARRANTIES OF MERCHANTABILITY AND FITNESS FOR A PARTICULAR PURPOSE, WITH RESPECT TO ACCESSORIES, EQUIPMENT, MATERIALS, OR COMPONENTS SOLD BUT NOT MANUFACTURED BY GRACO. These items sold, but not manufactured by Graco (such as electric motor, switches, hose, etc.) are subject to the warranty, if any, of their manufacturer. Graco will provide purchaser with reasonable assistance in making any claim for breach of these warranties.

**Factory Branches:** Atlanta, Chicago, Dallas, Detroit, Los Angeles, West Caldwell (N.J.)  
**Subsidiary and Affiliate Companies:** Canada; England; Korea; Switzerland; France; Germany; Hong Kong; Japan  
**GRACO INC. P.O. BOX 1441 MINNEAPOLIS, MN 55440-1441**