

Instructions-Parts List



SEVERE-DUTY, UHMWPE/PTFE PACKED Stainless Steel Pumps

308118S

EN

55 gallon (200 liter) drum size, with bung adapter.
For transfer and supply of solventborne and waterborne finishing materials.
For professional use only.



Important Safety Instructions
Read all warnings and instructions in this manual.
Save these instructions.

See page 2 for table of contents.

Model 224348, Series C  2575  II 1/2 G T2
10:1 Ratio President® Pump ITS03ATEX11228

Model 256713, Series A
10:1 Ratio President® Pump (1.5 in. Female Inlet)

1800 psi (12.4 MPa, 124 bar) Maximum Fluid Working Pressure
180 psi (1.25 MPa, 12.5 bar) Maximum Air Inlet Pressure

Model 224350, Series C  2575  II 1/2 G T2
5:1 Ratio Monark® Pump ITS03ATEX11228

Model 256714, Series A
5:1 Ratio Monark® Pump (1.5 in. Female Inlet)

900 psi (6.3 MPa, 63 bar) Maximum Fluid Working Pressure
180 psi (1.25 MPa, 12.5 bar) Maximum Air Inlet Pressure

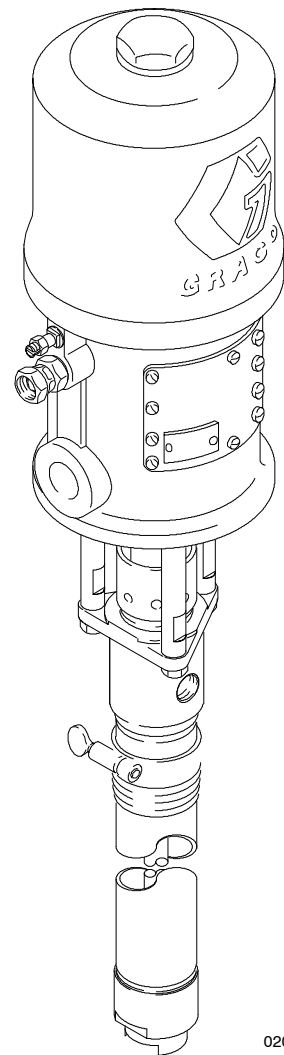

0200A

MODEL 224348 SHOWN

Table of Contents

Warnings	2
Installation	5
Operation	9
Troubleshooting	13
Service	14
Parts	18
Technical Data	22
Dimensions	26
Mounting Hole Layout	26
Warranty	28
Graco Information	28

Symbols

Warning Symbol



This symbol alerts you to the possibility of serious injury or death if you do not follow the corresponding instructions.

Caution Symbol



This symbol alerts you to the possibility of damage to or destruction of equipment if you do not follow the corresponding instructions.

! WARNING



INSTRUCTIONS

EQUIPMENT MISUSE HAZARD

Equipment misuse can cause the equipment to rupture or malfunction and result in serious injury.

- This equipment is for professional use only.
- Read all instruction manuals, tags, and labels before operating the equipment.
- Use the equipment only for its intended purpose. If you are uncertain about usage, call your Graco distributor.
- Do not alter or modify this equipment. Use only genuine Graco parts and accessories.
- Check equipment daily. Repair or replace worn or damaged parts immediately.
- Do not exceed the maximum working pressure of the lowest rated system component. Refer to the **Technical Data** on page 22 for the maximum working pressure of this equipment.
- Use fluids and solvents which are compatible with the equipment wetted parts. Refer to the **Technical Data** section of all equipment manuals. Read the fluid and solvent manufacturer's warnings.
- Do not use hoses to pull equipment.
- Route hoses away from traffic areas, sharp edges, moving parts, and hot surfaces. Do not expose Graco hoses to temperatures above 82°C (180°F) or below -40°C (-40°F).
- Wear hearing protection when operating this equipment.
- Do not lift pressurized equipment.
- Comply with all applicable local, state, and national fire, electrical, and safety regulations.

WARNING



SKIN INJECTION HAZARD

Spray from the gun/valve, hose leaks, or ruptured components can inject fluid into your body and cause extremely serious injury, including the need for amputation. Fluid splashed in the eyes or on the skin can also cause serious injury.



- Fluid injected into the skin might look like just a cut, but it is a serious injury. **Get immediate surgical treatment.**
- Do not point the gun/valve at anyone or at any part of the body.
- Do not put your hand or fingers over the spray tip/nozzle.
- Do not stop or deflect leaks with your hand, body, glove or rag.
- Do not “blow back” fluid; this is not an air spray system.
- Always have the tip guard and the trigger guard on the gun when spraying.
- Check the gun diffuser operation weekly. Refer to the gun manual.
- Be sure the gun/valve trigger safety operates before spraying/dispensing.
- Lock the gun/valve trigger safety when you stop spraying/dispensing.
- Follow the **Pressure Relief Procedure** on page 9 whenever you: are instructed to relieve pressure; stop spraying/dispensing; clean, check, or service the equipment; and install or clean the spray tip/nozzle.
- Tighten all fluid connections before operating the equipment.
- Check the hoses, tubes, and couplings daily. Replace worn, damaged, or loose parts immediately. Permanently coupled hoses cannot be repaired; replace the entire hose.
- Use only Graco approved hoses. Do not remove any spring guard that is used to help protect the hose from rupture caused by kinks or bends near the couplings.



MOVING PARTS HAZARD

Moving parts, such as the air motor piston, can pinch or amputate your fingers.

- Keep clear of all moving parts when starting or operating the pump.
- Before servicing the equipment, follow the **Pressure Relief Procedure** on page 9 to prevent the equipment from starting unexpectedly.

WARNING



FIRE AND EXPLOSION HAZARD

Improper grounding, poor ventilation, open flames or sparks can cause a hazardous condition and result in a fire or explosion and serious injury.



- Ground the equipment and the object being sprayed. Refer to **Grounding** on page 5.
- If there is any static sparking or you feel an electric shock while using this equipment, **stop spraying/dispensing immediately**. Do not use the equipment until you identify and correct the problem.
- Provide fresh air ventilation to avoid the buildup of flammable fumes from solvents or the fluid being sprayed/dispensed.
- Keep the spray/dispense area free of debris, including solvent, rags, and gasoline.
- Electrically disconnect all equipment in the spray/dispense area.
- Extinguish all open flames or pilot lights in the spray/dispense area.
- Do not smoke in the spray/dispense area.
- Do not turn on or off any light switch in the spray/dispense area while operating or if fumes are present.
- Do not operate a gasoline engine in the spray/dispense area.



TOXIC FLUID HAZARD

Hazardous fluid or toxic fumes can cause serious injury or death if splashed in the eyes or on the skin, inhaled, or swallowed.

- Know the specific hazards of the fluid you are using.
- Store hazardous fluid in an approved container. Dispose of hazardous fluid according to all local, state and national guidelines.
- Always wear protective eyewear, gloves, clothing and respirator as recommended by the fluid and solvent manufacturer.

Installation

Grounding

⚠ WARNING

FIRE AND EXPLOSION HAZARD
Before operating the pump, ground the system as explained below. Also read the section **FIRE AND EXPLOSION HAZARD** on page 4.

To reduce the risk of static sparking, ground the pump. Check your local electrical code for detailed grounding instructions for your area and type of equipment. Be sure to ground all of this dispensing equipment.

1. *Pump*: loosen the grounding lug locknut (W) and washer (X). Insert one end of a 1.5 mm² (12 ga) minimum ground wire (Y) into the slot in lug (Z) and tighten the locknut securely. See Fig. 1. Connect the other end of the ground wire to a true earth ground. Order Part No. 237569 Ground Wire and Clamp.
2. *Air and fluid hoses*: use only electrically conductive hoses with a maximum of 500 ft (150 m) combined hose length to ensure grounding continuity.
3. *Air compressor*: follow manufacturer's recommendation.

4. *Spray gun*: grounding is obtained through connection to a properly grounded fluid hose and pump.
5. *Object being sprayed*: according to your local code.
6. *Fluid supply container*: according to your local code.
7. *All solvent pails used when flushing*, according to your local code. Use only metal pails, which are conductive, placed on a grounded surface. Do not place the pail on a non-conductive surface, such as paper or cardboard, which interrupts the grounding continuity.
8. *To maintain grounding continuity when flushing or relieving pressure*, always hold a metal part of the spray gun firmly to the side of a grounded metal pail, then trigger the spray gun.

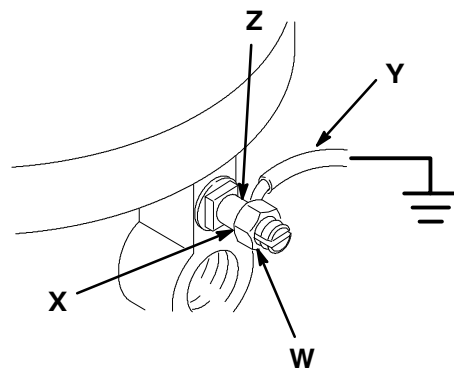
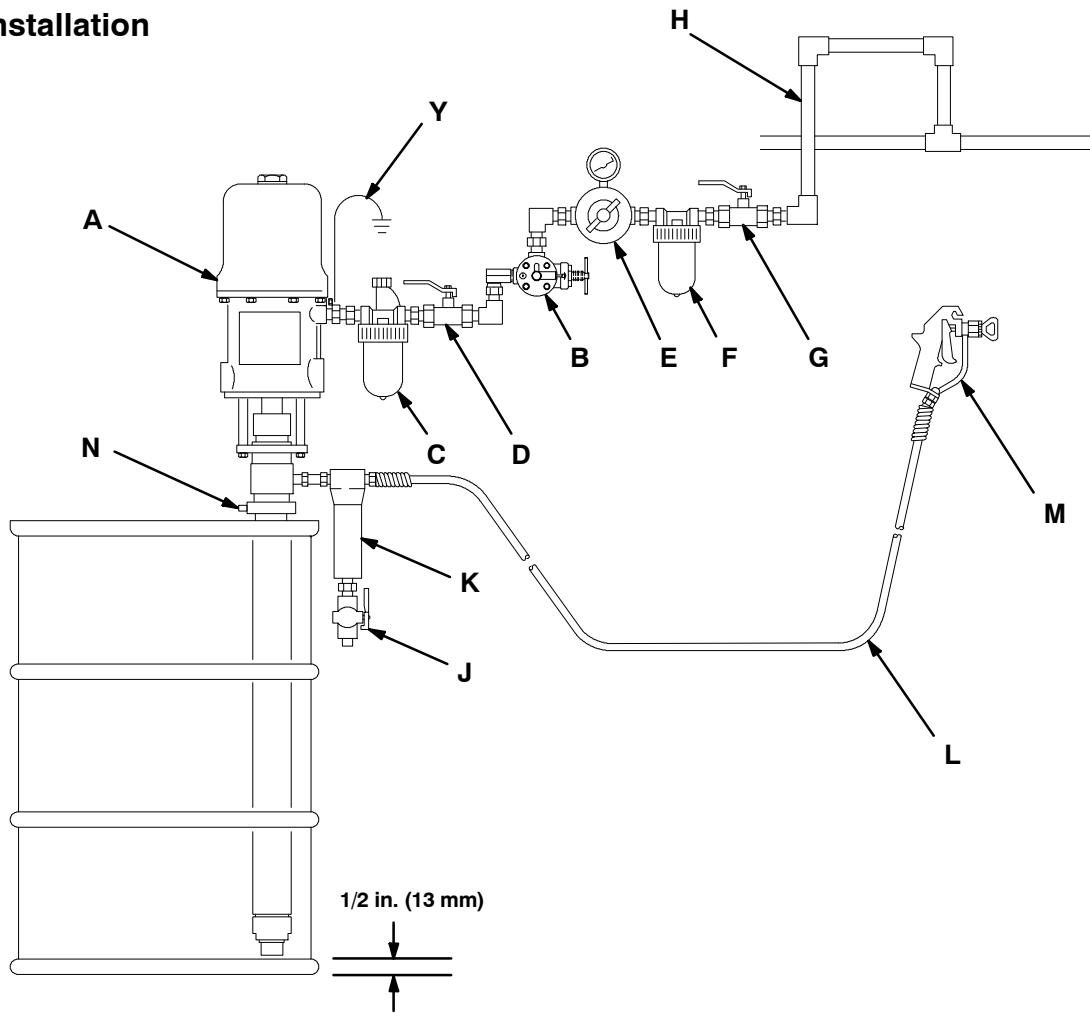

Fig. 1

0720

Installation

Typical Installation



0808A

KEY

- A** Pump
- B** Pump Runaway Valve
- C** Air Line Lubricator
- D** Bleed-Type Master Air Valve (required, for pump)
- E** Pump Air Regulator
- F** Air Line Filter
- G** Bleed-Type Master Air Valve (for accessories)
- H** Air Supply Hose
- J** Fluid Drain Valve (required)
- K** Fluid Filter
- L** Fluid Supply Hose
- M** Spray Gun
- N** Pump Bung Adapter
- Y** Ground Wire (required; see page 5 for installation instructions)

Installation

NOTE: Reference numbers and letters in parentheses in the text refer to the callouts in the figures and the Parts Drawing.

NOTE: Contact your Graco distributor for available Graco accessories. If you supply your own accessories, be sure they are adequately sized and pressure-rated to meet the system's requirements.

The **Typical Installation** shown on page 6 is only a guide for selecting and installing system components and accessories. Contact your Graco distributor for assistance in designing a system to suit your particular needs.

System Accessories

Refer to the **Typical Installation** on page 6.

WARNING

A bleed-type master air valve (D) and a fluid drain valve (J) are required in your system. These accessories help reduce the risk of serious injury including fluid injection, splashing in the eyes or on the skin, and injury from moving parts if you are adjusting or repairing the pump.

The bleed-type master air valve relieves air trapped between this valve and the pump after the air is shut off. Trapped air can cause the pump to cycle unexpectedly. Locate the valve close to the pump.

The fluid drain valve assists in relieving fluid pressure in the displacement pump, hose, and gun. Triggering the gun to relieve pressure may not be sufficient.

Mounting Accessories

Mount the pump (A) to suit the type of installation planned. The pump dimensions and mounting hole layout are shown on page 26.

The pump is supplied with a bung adapter. To mount the pump, loosen the bung adapter screw and slide the adapter off the pump. Screw the bung adapter securely into the bung hole on the cover of the supply drum. Carefully lower the pump through the bung adapter and into the drum until it rests on the bottom, then pull it back up 1/2 in. (13 mm). Tighten the bung adapter screw to hold the pump in this position. Open the drum's vent plug to prevent a vacuum from forming in the drum.

Air and Fluid Hoses

Be sure all air and fluid hoses are properly sized and pressure-rated for your system. Use only electrically conductive air and fluid hoses. Fluid hoses must have spring guards on both ends.

Connect a electrically conductive fluid hose (L) to the fluid filter (K), if used, or directly to the pump's fluid outlet.

Use a electrically conductive 1/2 in. ID (minimum) air hose (H) to supply air to the pump.

Air Line Accessories

Install the following accessories in the order shown in the **Typical Installation**, using adapters as necessary.

- **An air line lubricator (C)** provides automatic air motor lubrication.
- **A bleed-type master air valve (D)** is required in your system to relieve air trapped between it and the air motor when the valve is closed (see the **WARNING** at left). Be sure the bleed valve is easily accessible from the pump, and is located downstream from the air regulator.
- **A pump runaway valve (B)** senses when the pump is running too fast and automatically shuts off the air to the motor. A pump which runs too fast can be seriously damaged.
- **An air regulator (E)** controls pump speed and outlet pressure by adjusting the air pressure to the pump. Locate the regulator close to the pump, but upstream from the bleed-type master air valve.
- **An air line filter (F)** removes harmful dirt and moisture from the compressed air supply.
- **A second bleed-type master air valve (G)** isolates the air line accessories for servicing. Locate upstream from all other air line accessories.

Fluid Line Accessories

Install the following accessories in the positions shown in the **Typical Installation**, using adapters as necessary:

- **A fluid drain valve (J)** is required in your system to relieve fluid pressure in the hose and gun (see the **WARNING** at left). Install the drain valve pointing down, but so the handle points up when opened.
- **A fluid filter (K)** filters harmful particles from the fluid.
- **A spray gun (M)** dispenses the fluid. The gun shown in the **Typical Installation** is an airless spray gun.

Operation

Pressure Relief Procedure

WARNING

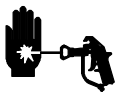

SKIN INJECTION HAZARD

Fluid under high pressure can be injected through the skin and cause serious injury. To reduce the risk of an injury from injection, splashing fluid, or moving parts, follow the **Pressure Relief Procedure** whenever you:

- are instructed to relieve the pressure,
- stop spraying,
- check or service any of the system equipment,
- or install or clean the spray tips.

1. Lock the spray gun trigger safety.
2. Shut off the air to the pump.
3. Close the bleed-type master air valve (required in your system).
4. Unlock the gun trigger safety.
5. Hold a metal part of the gun firmly to the side of a grounded metal pail, and trigger the gun to relieve pressure.
6. Lock the spray gun trigger safety.
7. Open the drain valve (required in your system), having a container ready to catch the drainage.
8. Leave the drain valve open until you are ready to spray again.

If you suspect that the spray tip or hose is completely clogged, or that pressure has not been fully relieved after following the steps above, very slowly loosen the tip guard retaining nut or hose end coupling and relieve pressure gradually, then loosen completely. Now clear the tip or hose.

WARNING

Moving parts can pinch or amputate your fingers or other body parts. When air is supplied to the motor, the air motor piston (located behind the air motor plates) moves. See Fig. 2. Therefore, never operate the pump with the air motor plates removed.

Flush the Pump Before Using

The pump is tested with lightweight motor oil, which is left in to protect the pump parts. If the fluid you are using may be contaminated by the oil, flush it out with a compatible solvent before using the pump. If the pump is being used to supply a circulating system, allow the solvent to circulate until the pump is thoroughly flushed.

WARNING



FIRE AND EXPLOSION HAZARD

For your safety, read the section **FIRE AND EXPLOSION HAZARD** on page 4 before flushing and follow all the recommendations given there.



Operation

Starting and Adjusting the Pump

WARNING

To reduce the risk of serious injury whenever you are instructed to relieve pressure, always follow the **Pressure Relief Procedure** on page 9.

See the **Typical Installation** on page 6. Be sure the air regulator (E) and bleed-type master air valve (D) are closed. Do not install the spray tip yet.

Mount the pump on the supply drum. On bung-style drums, open the vent plug to prevent a vacuum from forming in the drum. Hold a metal part of the spray gun (M) firmly to the side of a grounded metal pail and hold the trigger open. Then open the pump's bleed-type master air valve (D). Now slowly open the air regulator until the pump starts, about 40 psi (280 kPa, 2.8 bar).

Cycle the pump slowly until the air is pushed out and the pump and hoses are fully primed. Release the spray gun trigger and engage the safety latch. The pump should stall against pressure when the trigger is released.

Relieve the pressure, then install the spray tip in the gun.

With the pump and lines primed, and with adequate air pressure and volume supplied, the pump will start and stop as the spray gun is opened and closed. In a circulating system, the pump will run continuously and will speed up or slow down as supply demands until the air supply is shut off.

Use an adequately sized air regulator (E) to control the pump speed and the fluid pressure. Always use the lowest air pressure necessary to get the desired results. Higher pressures waste fluid and cause premature wear of the packings and spray tip.

WARNING

To reduce the risk of overpressurizing your system, which could result in component rupture and cause serious injury, never exceed the *Maximum Incoming Air Pressure* given on your pump or in the **Technical Data** on pages 22 and 24.

Keep the packing nut/wet-cup (14) filled with Graco Throat Seal Liquid (TSL) or compatible solvent, to help prolong the packing life. Adjust the packing nut weekly so it is just tight enough to prevent leakage; do not overtighten. See Fig. 2. Always **relieve the pressure** before adjusting the packing nut.

Never allow the pump to run dry of the fluid being pumped. A dry pump will quickly accelerate to a high speed, possibly damaging itself. A pump runaway valve (B), which shuts off the air supply to the pump if the pump accelerates beyond the pre-set speed, is available. If your pump accelerates quickly, or is running too fast, stop it immediately and check the fluid supply. If the supply container is empty and air has been pumped into the lines, refill the container and prime the pump and the lines with fluid, or flush and leave it filled with a compatible solvent. Be sure to eliminate all air from the fluid system.

Shutdown and Care of the Pump

WARNING

To reduce the risk of serious injury whenever you are instructed to relieve pressure, always follow the **Pressure Relief Procedure** on page 9.

For overnight shutdown, **relieve the pressure**. Always stop the pump at the bottom of the stroke to prevent the fluid from drying on the exposed displacement rod and damaging the throat packings.

Always flush the pump before the fluid dries on the displacement rod. **Relieve the pressure** after flushing.

Operation

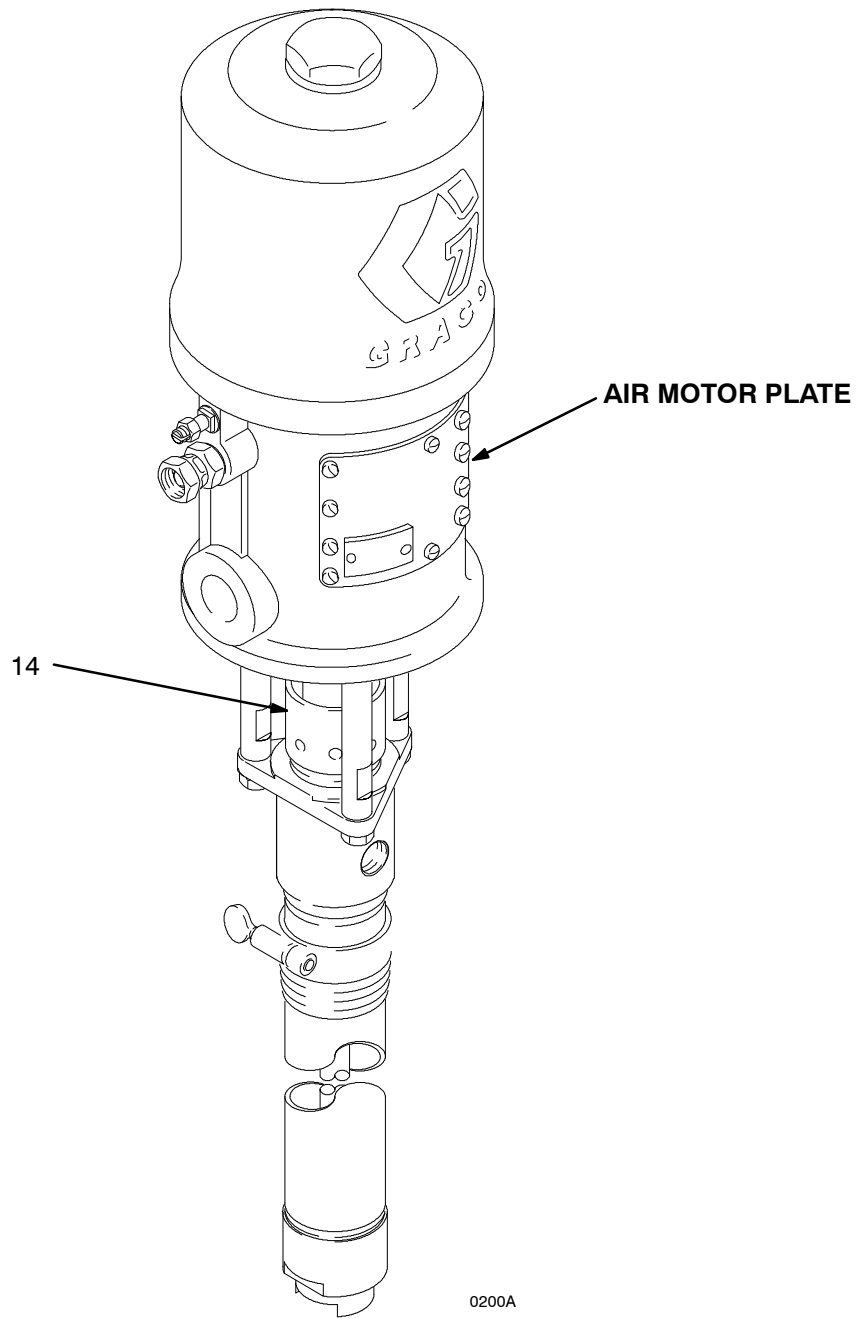

Fig. 2

Troubleshooting

WARNING

To reduce the risk of serious injury whenever you are instructed to relieve pressure, always follow the **Pressure Relief Procedure** on page 9.

Before servicing this equipment always make sure to **relieve the pressure**.

Check all possible problems and solutions before disassembling the pump.

Problem	Cause	Solution
Pump fails to operate	Restricted line or inadequate air supply	Clear; Increase air supply.
	Insufficient air pressure; closed or clogged air valves, etc.	Open, clean.
	Exhausted fluid supply	Refill; purge all air from pump and fluid lines.
	Damaged air valving mechanism; stalling	Service air motor (see manual 306982 or 307043).
	Dried fluid seizure of displacement rod (1)	Clean, check or replace throat packings (3, 25); always stop the pump at the bottom of its stroke and keep the wet-cup filled with compatible solvent.
Pump operates, but output low on both strokes	Restricted line or inadequate air supply	Clear; increase air supply.
	Insufficient air pressure; closed or clogged air valves, etc.	Open, clean.
	Exhausted fluid supply	Refill; purge all air from pump and fluid lines.
	Clogged fluid line, valves, etc.	Clear*.
	Packing nut (14) too tight	Loosen (see page 10).
	Loose packing nut (14) or worn throat packings (3, 25)	Tighten packing nut (see page 10); replace throat packings.
Pump operates, but output low on down stroke	Held open or worn intake valve.	Clear; service.
Pump operates, but output low on up stroke	Held open or worn fluid piston valve or packings (29, 30)	Clear; service.
Erratic or accelerated operation	Exhausted fluid supply	Refill; purge all air from the pump and fluid lines.
	Help open or worn intake valve.	Clear; service.
	Help open or worn fluid piston valve or packings (29, 30)	Clear; service.

* To determine if the fluid hose or gun is obstructed, **relieve the pressure**. Disconnect the fluid hose and place a container at the pump fluid outlet to catch any fluid. Turn on the air just enough to start the pump (about 20-40 psi [140-280 kPa, 1.4-2.8 bar]). If the pump starts when the air is turned on, the obstruction is in the fluid hose or gun.

Service

Disconnecting the Displacement Pump

⚠ WARNING

To reduce the risk of serious injury whenever you are instructed to relieve pressure, always follow the **Pressure Relief Procedure** on page 9.

1. Flush the pump, if possible. Stop the pump at the bottom of its stroke. **Relieve the pressure.**
2. Disconnect the air and fluid hoses. Remove the pump from its mounting. Note the relative position of the pump's fluid outlet (R) to the air motor's air inlet (S).
3. Unscrew the tie rod locknuts (112) from the tie rods (102). Remove the cotter pin (109). Unscrew the displacement rod (1) from the air motor (106). Carefully pull the displacement pump (101) away from the air motor (106). Inspect the o-ring (105). See Fig. 3.
4. Refer to page 15 for displacement pump service. To service the air motor, refer to the separate air motor manual (306982 or 307043), supplied.

Reconnecting the Displacement Pump

1. Lubricate the o-ring (105) and check that it is in place on the displacement rod (1). Orient the pump's fluid outlet (R) to the air motor's air inlet (S) as was noted in step 2 under **Disconnecting the Displacement Pump**. Position the displacement pump (101) on the tie rods (102). Screw the locknuts (112) onto the tie rods (102) loosely. See Fig. 3.
2. Screw the displacement rod (1) into the shaft of the air motor (106) until the pin holes in the rod and shaft align. Install the cotter pin (109).
3. Mount the pump and reconnect all hoses. Reconnect the ground wire if it was disconnected during repair. Tighten the packing nut/wet-cup (14) so it is just snug - no tighter. Fill the wet-cup with Graco Throat Seal Liquid or compatible solvent.
4. Tighten the tie rod locknuts (112) evenly, and torque as shown in Fig. 3.
5. Start the pump and run it at about 40 psi (280 kPa, 2.8 bar) air pressure, to check that it is operating properly.
6. Check for fluid leakage at the packing nut/wet-cup (14). **Relieve the pressure** before tightening the packing nut/wet-cup.

- 1 Torque to 20-30 ft-lb
(27-41 N•m) on Model 224348
Torque to 10-15 ft-lb
(14-20 N•m) on Model 224350
- 2 Lubricate

**MODEL
224348
SHOWN**

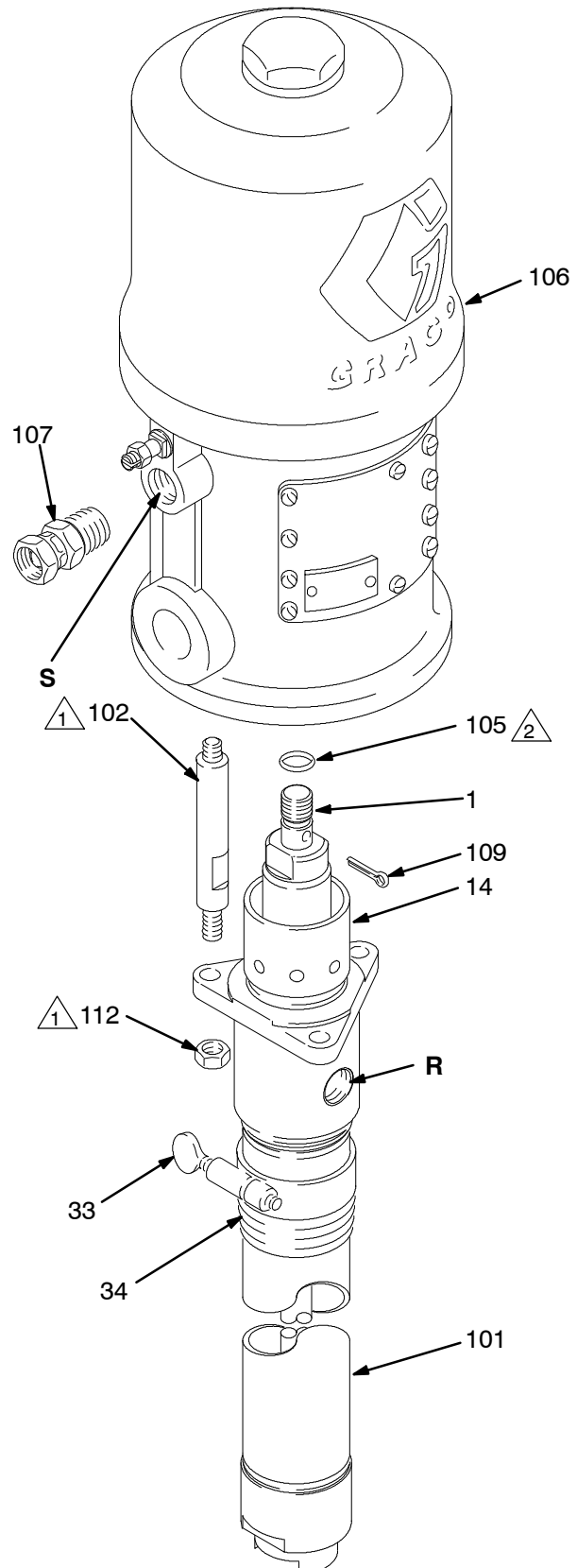

Fig. 3

0199B

Service

Displacement Pump Service

Disassembly

When disassembling the pump, lay out all removed parts in sequence to ease reassembly. See Fig. 5.

NOTES

- Standard Repair Kit 224403 (UHMWPE/PTFE packings) is available. For the best results, use all the new parts in the kit. Parts included in the kit are denoted with one asterisk, for example (2*).
 - Conversion Kit 224889 is available to convert the pump to all PTFE packings. See page 18.
 - Clean all the parts thoroughly when disassembling. Check them carefully for damage or wear, replacing parts as needed.
1. Remove the displacement pump from the air motor as explained on page 14.
 2. Unscrew the locking ring (20) from the cylinder (15). See Fig. 5. Remove the intake valve housing (21).
 3. Remove the o-ring (19), ball stop pin (17), and ball (18) from the intake valve housing (21).
 4. Unscrew the cylinder (15) from the outlet housing (5), note its orientation and carefully pull the cylinder off the pump. Remove the o-ring (6) from the outlet housing.
NOTE: It is important to replace the cylinder in the same orientation as both ends are NOT alike. Failure to install correctly may result in failure of pump or premature seal wear. For instructions on how to verify correct orientation, see NOTE in step 7 on page 16.
 5. Loosen the packing nut (14), then pull the displacement rod (1) and connecting rod (8) out the bottom of the outlet housing (5).
 6. Secure the flats of the displacement rod (1) in a vise. Unscrew the coupling nut (7) from the displacement rod. Remove the connecting rod (8) and attached parts.
 7. Place the flats of the piston mounting stud (13) in a vise. Loosen the jam nut (9) and unscrew the adapter (10) from the piston mounting stud (13). Set the connecting rod (8) aside. Remove one cotter pin (12) and the ball stop pin (11), taking note which set of holes it is in. Then remove the ball (16).
 8. Unscrew the piston stud (27) from the piston mounting stud (13). Remove the piston packings (29, 30), glands (28, 31), shims (35), and washer (26).
 9. Remove the packing nut (14), throat packings (3, 25), and glands (2, 4) from the outlet housing (5).
 10. Inspect all parts for damage. Clean all parts and threads with a compatible solvent before reassembling. Inspect the polished outer surface of the displacement rod (1) and inner surface of the cylinder (15) for scratches, scoring, or other damage, which can cause premature packing wear and leaking. To check, run a finger over the surface or hold the part up to the light at an angle. Be sure the ball seats of the piston (27) and intake valve housing (21) are not chipped or nicked. Replace any worn or damaged parts.

Service

Displacement Pump Service

Reassembly

1. Lubricate the throat packings and install them in the outlet housing (5) one at a time as follows, *with the lips of the v-packings facing down*: the male gland (4*), one UHMWPE v-packing (3*), two PTFE v-packings (25*), one UHMWPE v-packing (3*), and the female gland (2*). Apply thread lubricant to the packing nut (14), and screw it loosely into the outlet housing. See Fig. 5.
2. Lubricate the piston packings and install them on the piston stud (27) one at a time in the following order, *with the lips of the v-packing facing up*: the shims (35; use 0–3 as required), the female gland (31*), one UHMWPE v-packing (30*), two PTFE v-packings (29*), one UHMWPE v-packing (30*), the male gland (28*), and the washer (26*). See Fig. 5.
3. Apply thread sealant and screw the piston stud (27) onto the piston mounting stud (13). Torque to 50–70 ft-lb (68–95 N•m). Install the piston ball (16*) on the piston seat. Slide the ball stop pin (11*) into the desired set of holes, and secure with the cotter pin (12*).
4. Check that the coupling nut (7), jam nut (9) and adapter (10) are in place on the connecting rod (8). The bottom of the adapter (10) should be flush with the end of the rod (8); tighten the jam nut (9) down securely to lock these parts. Apply thread sealant to the male threads of the adapter (10). Screw the piston mounting stud (13) onto the connecting rod adapter (10), and torque to 50–70 ft-lb (68–95 N•m).
5. Place the flats of the displacement rod (1) in a vise. Apply thread lubricant to the bottom threads of the rod. Couple the connecting rod (8) to the displacement rod with the coupling nut (7). Tighten the nut securely.
6. Place the o-ring (6) into the outlet housing (5). Slide the displacement rod and connecting rod assembly up into the outlet housing (5) until the displacement rod protrudes from the packing nut (14).

NOTE: Before replacing the pump cylinder, note its orientation. Failure to install correctly may result in failure of pump or premature seal wear. Inspect the inner diameter of both ends of the cylinder for smoothness and size. The rougher and larger end should mate with the outlet housing (5) upon reassembly.

7. A special assembly tool, Part No. 168085, should be used to install the piston assembly into the cylinder. This tool is made from 0.016 (0.41 mm) shim stock and helps protect the edges of the packings from damage during reassembly. Place the tool around the piston packings as shown in Fig. 4. Start the bottom packings (35) into the cylinder and then remove the tool.

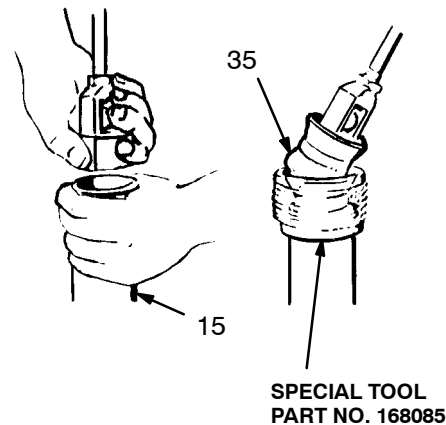

Fig. 4

8. Apply thread lubricant to the top threads of the cylinder (15). Slide the cylinder straight up over the connecting rod (8) and displacement rod (1), being careful not to scratch the cylinder by tilting it. Screw the cylinder into the outlet housing (5).
9. Install the ball (18*), o-ring (19) and ball stop pin (17*) in the intake valve housing (21). Apply thread lubricant to the bottom threads of the cylinder (15). Place the intake valve assembly in the locking ring (20), and screw the ring onto the cylinder (15).
10. Reconnect the displacement pump to the motor as explained on page 14.

Service

1 Apply sealant and torque to 50-70 ft-lb (68-95 N•m)

2 Apply thread lubricant

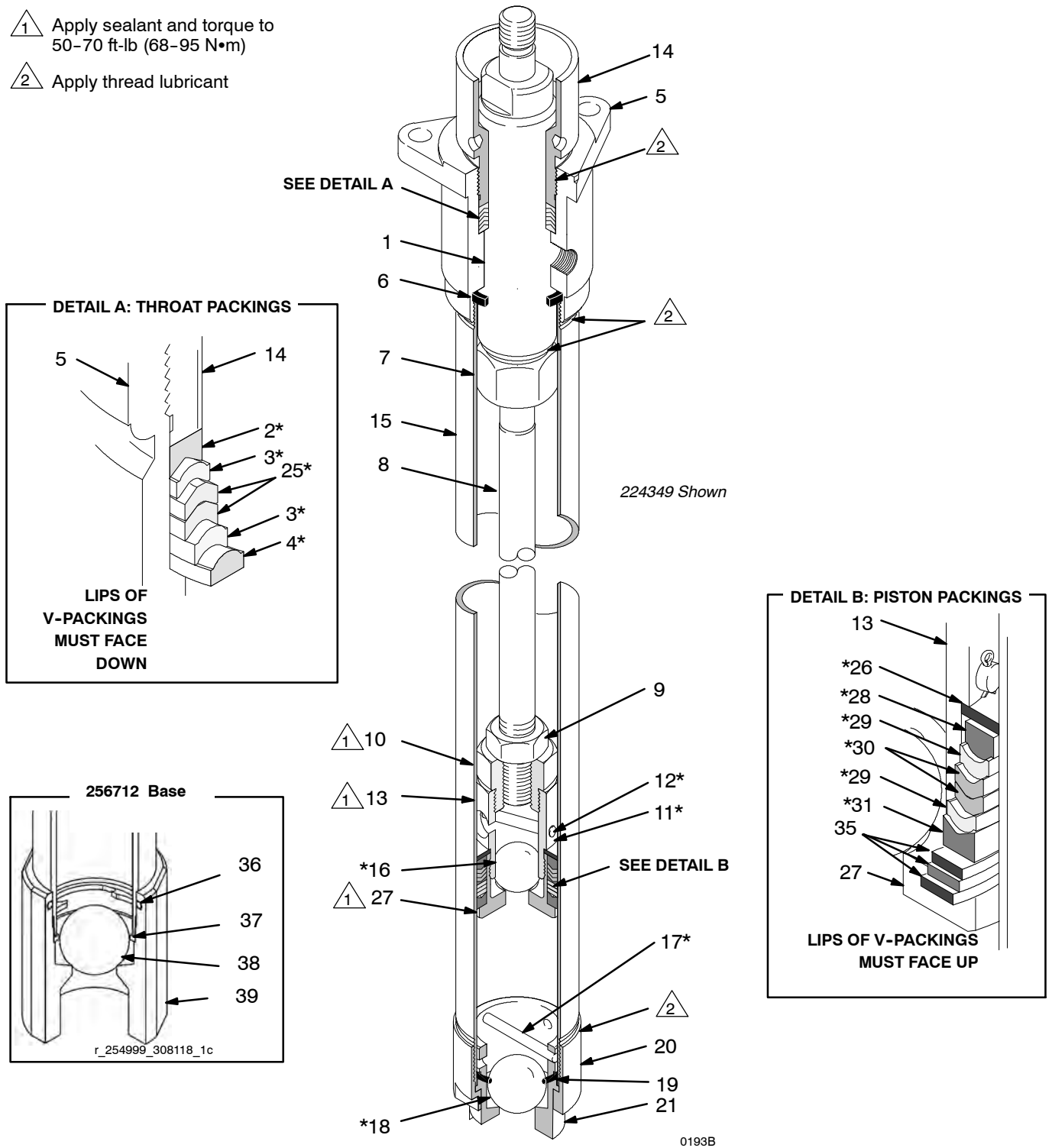
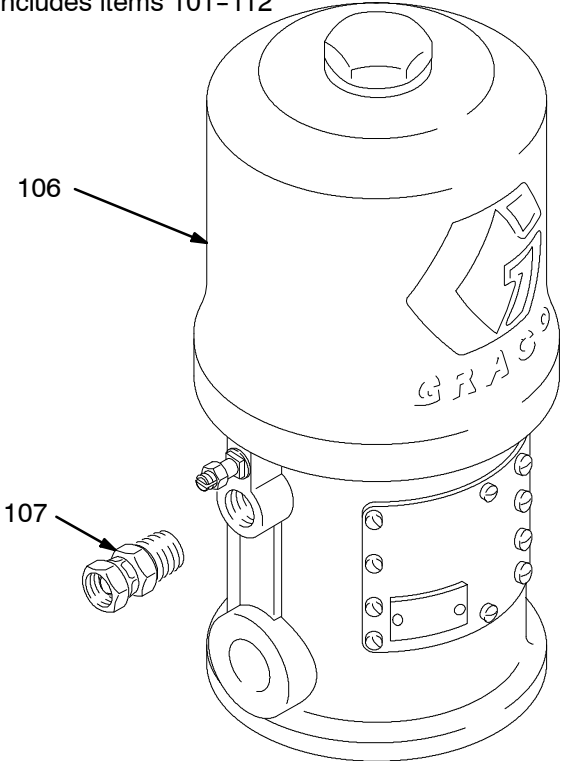

Fig. 5

Parts

Model 224348, Series C
10:1 Ratio President® Pump
Model 256713, Series A
10:1 Ratio President® Pump (1.5 in. Female Inlet)
 Includes items 101-112



REF NO.	PART NO.	DESCRIPTION	QTY
101	224349‡	DISPLACEMENT PUMP ASSY See pages 20 and 21 for parts	1
	256712*	DISPLACEMENT PUMP ASSY, 1.5 in. female inlet See pages 20 and 21 for parts	1
102	166237	ROD, tie; stainless steel; 3.5" (89 mm) shoulder-to-shoulder	3
105†	156082	SEAL, o-ring; nitrile rubber	1
106	207352	AIR MOTOR See manual 306982 for parts	1
107	158256	ADAPTER, swivel; 1/2 npt(m) x 3/8 npsm(f)	1
109†	101946	PIN, cotter; stainless steel; 0.12" (3.2 mm) x 1.5" (3.8 mm)	1
112	102021	NUT, lock; 3/8-16; stainless steel	3

† Recommended "tool box" spare parts. Keep on hand to reduce downtime.

‡ For 224348 assembly

* For 256713 assembly

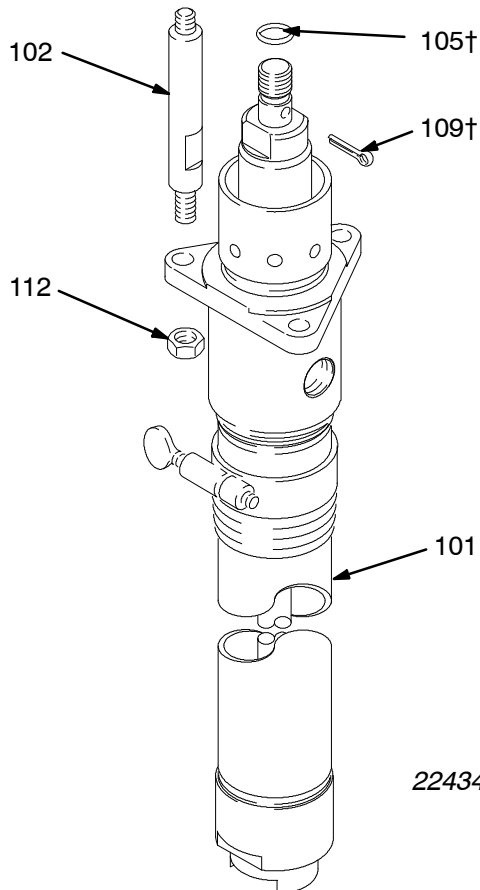

224348 shown

Parts

Model 224350, Series C
5:1 Ratio Monark® Pump
Model 256714, Series A
5:1 Ratio Monark® Pump (1.5 in. Female Inlet)
 Includes items 101-112

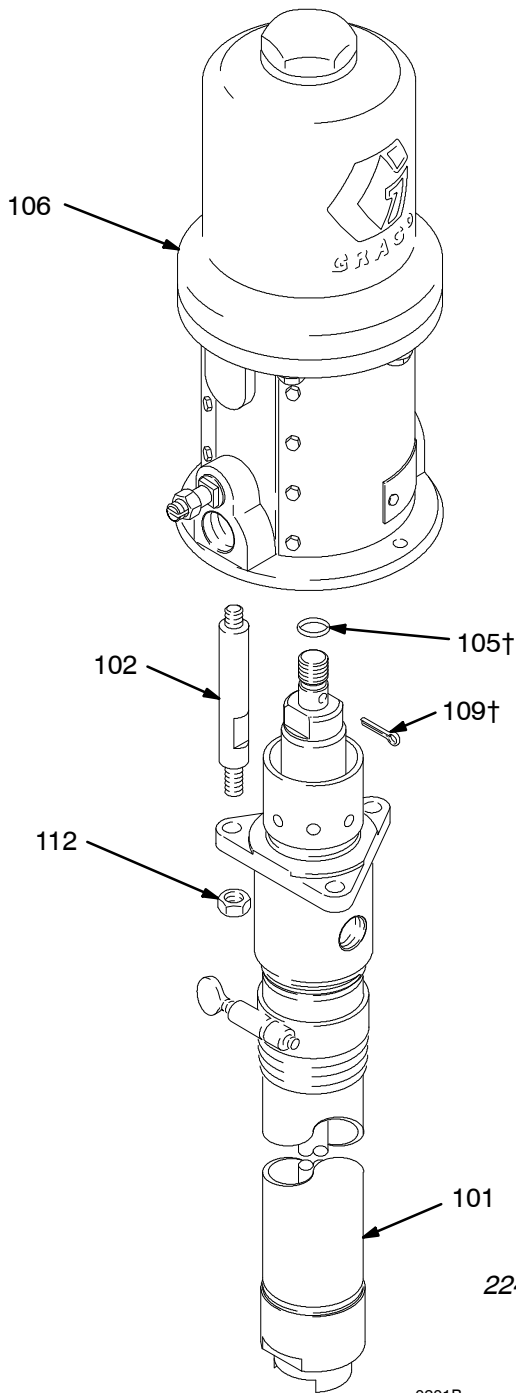

REF NO.	PART NO.	DESCRIPTION	QTY
101	224349 †	DISPLACEMENT PUMP ASSY	1
	256712 *	DISPLACEMENT PUMP ASSY, 1.5 in. female inlet	1
102	24B189	ROD, tie; stainless steel; 3.5" (89 mm) shoulder-to-shoulder	3
105 †	156082	SEAL, o-ring; nitrile rubber	1
106	205997	AIR MOTOR	1
109 †	101946	PIN, cotter; stainless steel; 0.12" (3.2 mm) x 1.5" (3.8 mm)	1
112	102021	NUT, lock; 3/8-16; stainless steel	3

† Recommended "tool box" spare parts. Keep on hand to reduce downtime.

‡ For 224350 assembly

* For 256714 assembly

Parts

Model 224349, Series C
Severe-Duty, Stainless Steel Displacement Pump
Model 256712, Series A
Severe-Duty, Stainless Steel Displacement Pump (1.5 in. Female Inlet)
 Includes items 1-34

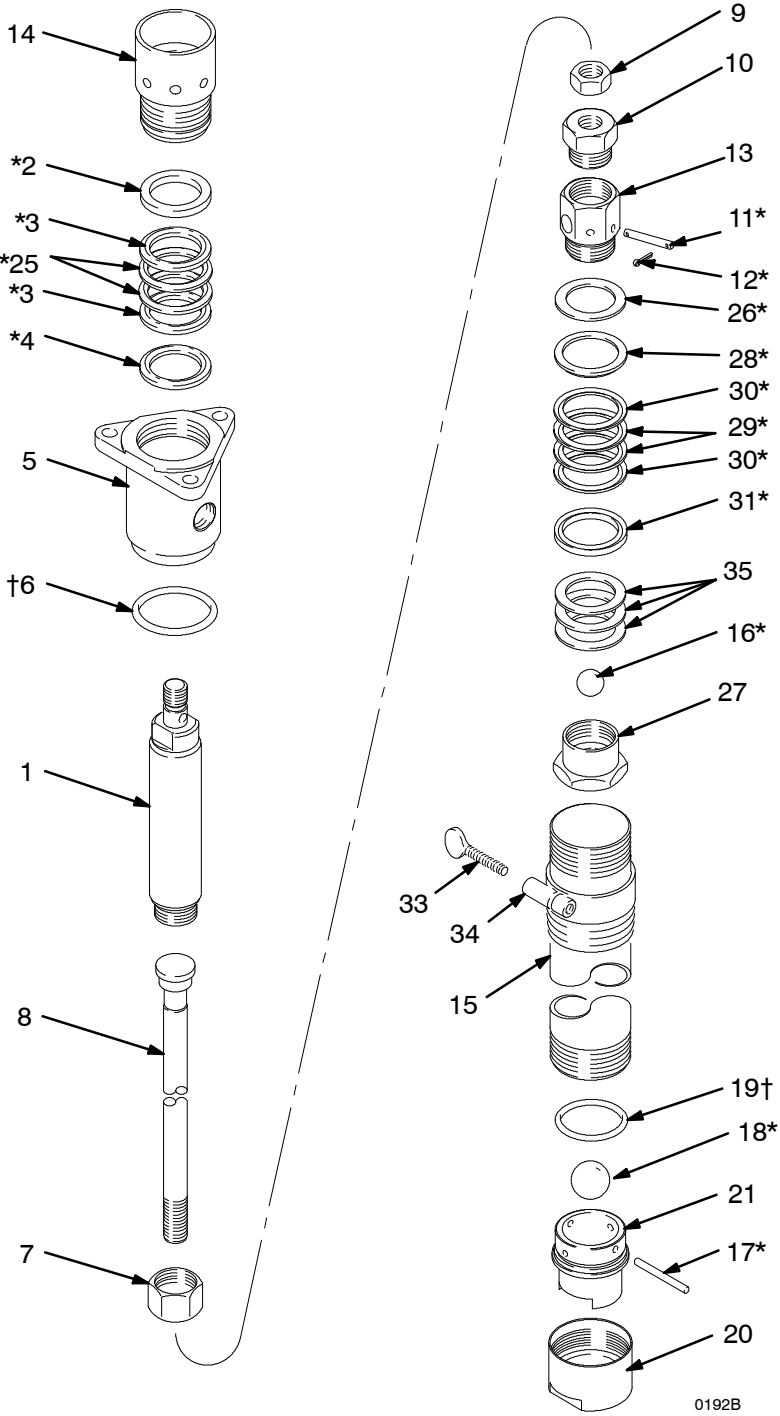

224349 Shown

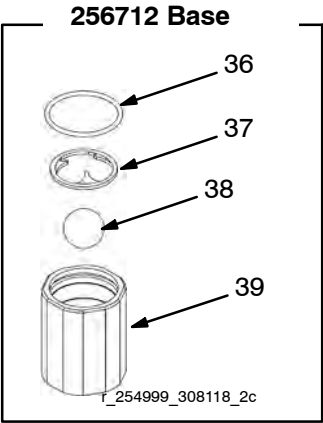

0192B

Parts

Model 224349, Series C Severe-Duty, Stainless Steel Displacement Pump

Includes items 1-35

Model 256712, Series A

Severe-Duty, Stainless Steel Displacement Pump (1.5 in. Female Inlet)

Includes items 1-16, 22-39

REF NO.	PART NO.	DESCRIPTION	QTY	OPTIONAL PTFE PACKING CONVERSION KIT 224889		
1	24C506	ROD, displacement; stainless steel	1	Use to convert the pump to all PTFE packings. Kit must be purchased separately. Includes the following items:		
2*	186988	GLAND, throat, female; stainless steel	1			
3*	176639	V-PACKING, throat; UHMWPE	2			
4*	186987	GLAND, throat, male; stainless steel	1			
5	192188	HOUSING, outlet; stainless steel	1			
6†	164782	O-RING; PTFE	1			
7	166033	NUT, coupling	1			
8	206449	ROD, connecting; stainless steel	1			
9	166037	NUT, jam; 5/8-11 unc-2b; stainless steel	1			
10	166036	ADAPTER, connecting rod; stainless steel	1			
11*	176637	PIN, ball stop, piston; stainless steel	1	100063	PIN, cotter; 1/16 in. x 1/2 in.; stainless steel	2
12*	100063	PIN, cotter; 1/16" x 1/2"; stainless steel	2	162866	V-PACKING; PTFE	4
13	176644	STUD, mounting, piston; stainless steel	1	162947	PIN, ball stop, intake; stainless steel	1
14	186995	PACKING NUT/WET-CUP; stainless steel	1	186987	GLAND, throat, male; stainless steel	1
15	24C504	CYLINDER; stainless steel	1	186988	GLAND, throat, female; stainless steel	1
16*	101917	BALL, piston; stainless steel; 0.875" (22 mm) dia.	1	176634	WASHER, piston; stainless steel	1
17*	162947	PIN, ball stop, intake; stainless steel	1	176635	V-PACKING, piston; PTFE	4
18*	101968	BALL, intake; stainless steel; 1.25" (31 mm) dia.	1	176637	PIN, ball stop, piston; stainless steel	1
19†	164846	O-RING; PTFE	1	186989	GLAND, piston, female; stainless steel	1
20	164630	RING, locking; stainless steel	1	186990	GLAND, piston, male; stainless steel	1
21	186991	HOUSING, valve, intake; stainless steel	1	190484	SHIM (use as required)	3
25*	162866	V-PACKING, throat; PTFE	2			
26*	176634	WASHER, piston; stainless steel	1			
27	186993	STUD, piston; stainless steel	1			
28*	186990	GLAND, piston, male; stainless steel	1			
29*	176635	V-PACKING, piston; PTFE	2			
30*	176638	V-PACKING, piston; UHMWPE	2			
31*	186989	GLAND, piston, female; stainless steel	1			
32	205573	BUNG ADAPTER				
		Includes items 33 and 34	1			
33	101961	. THUMBSCREW; 1/4-20 unc x 1.5" (3.8 mm) long	1			
34	205572	. ADAPTER, bung; stainless steel	1			
35	190484	SHIM	3			
36	C38225	PACKING, o-ring	1			
37	15J577	RETAINER, ball, foot valve	1			
38	101178	BALL, metallic	1			
39	15J574	HOUSING, valve, intake	1			

* The replacements for these parts are available in Standard Repair Kit 224403 (UHMWPE/PTFE packings). Purchase the kit separately.

† Recommended "tool box" spare parts. Keep on hand to reduce downtime.

Technical Data (10:1 President)

Category	Data
Maximum fluid working pressure	1800 psi (12.4 MPa, 124 bar)
Maximum air input pressure	180 psi (1.25 MPa, 12.5 bar)
Pump cycles per 1 gallon (3.8 liters)	20
Fluid flow at 60 cpm	3 gallon (11.4 liters)
Recommended speed for optimum pump life	15–25 cycles/min; 0.75–1.25 gpm (2.84 to 4.73 liters/min)
Air consumption	approx. 15 scfm (0.42 m ³ /min) at 1 gpm (3.8 liters/min) at 100 psi (0.7 MPa, 7 bar) air pressure
Weight	approx. 43 lb (19.5 kg)
Wetted parts	AISI 302, 303, 304, 316, and 17-4 PH grades of Stainless Steel; Chrome Plating; PTFE; Ultra-High Molecular Weight Polyethylene

Technical Data (10:1 President)

Fluid Outlet Pressure Chart

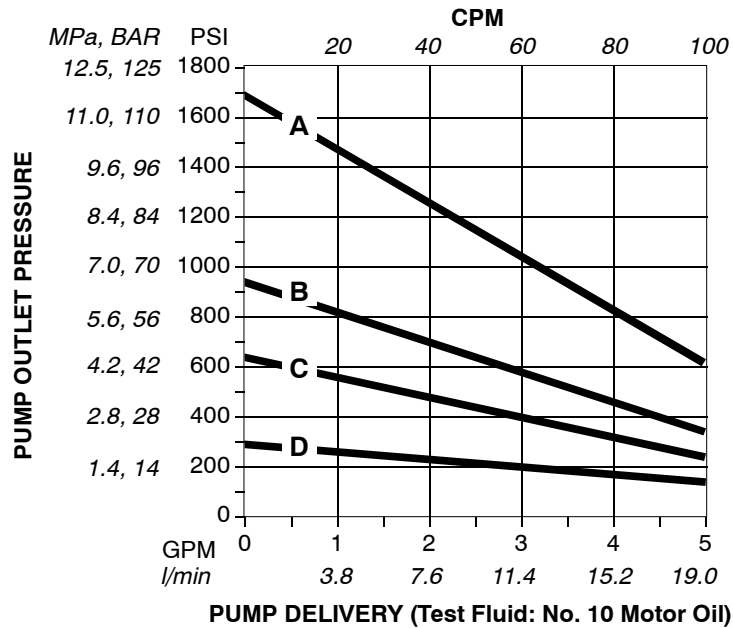

- A 1.25 MPa, 12.5 bar (180 psi) air pressure
- B 0.7 MPa, 7 bar (100 psi) air pressure
- C 0.49 MPa, 4.9 bar (70 psi) air pressure
- D 0.28 MPa, 2.8 bar (40 psi) air pressure

To find Outlet Pressure (MPa/bar/psi) at a specific delivery (liter/min or gpm) and operating air pressure (MPa/bar/psi):

1. Locate desired delivery along bottom of chart.
2. Read vertical line up to intersection with selected fluid outlet pressure curve. Curve slopes from left to right. Follow left to scale and read outlet pressure.

Air Consumption Chart

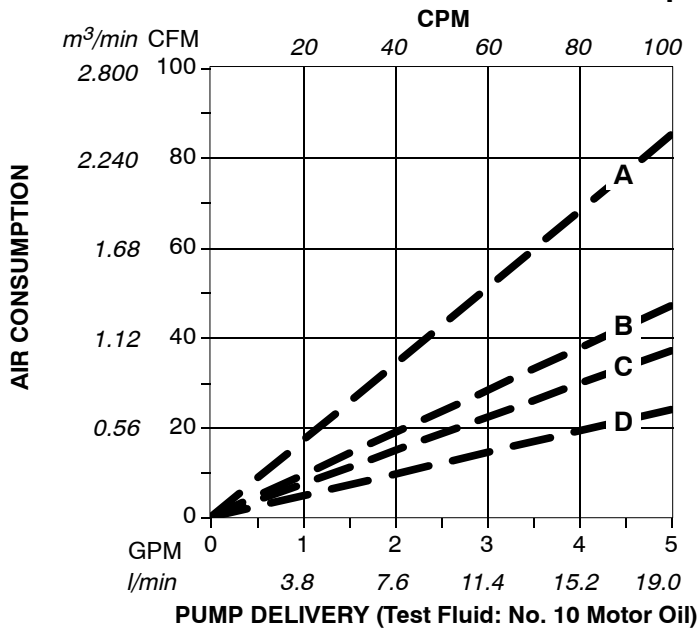

- A 1.25 MPa, 12.5 bar (180 psi) air pressure
- B 0.7 MPa, 7 bar (100 psi) air pressure
- C 0.49 MPa, 4.9 bar (70 psi) air pressure
- D 0.28 MPa, 2.8 bar (40 psi) air pressure

To find Pump Air Consumption (m³/min or CFM/min) at a specific delivery (liter/min or gpm) and operating air pressure (MPa/bar/psi):

1. Locate desired delivery along bottom of chart.
2. Read vertical line up to intersection with selected air consumption curve. Curve slopes from right to left. Follow left to scale and read air consumption.

Technical Data (5:1 Monark)

Category	Data
Maximum fluid working pressure	900 psi (6.3 MPa, 63 bar)
Maximum air input pressure	180 psi (1.25 MPa, 12.5 bar)
Pump cycles per 1 gallon (3.8 liters)	24
Maximum recommended pump speed for continuous operation	60 cycles/min
Fluid flow at 60 cpm	2.5 gallon (9.46 liters)
Recommended speed for optimum pump life	15-25 cycles/min; 0.63-1.04 gpm (2.38 to 3.94 liters/min)
Air consumption	approx. 8.2 scfm (0.23 m ³ /min) at 1 gpm (3.8 liters/min) at 100 psi (0.7 MPa, 7 bar) air pressure
Weight	approx. 30 lb (13.6 kg)
Wetted parts	AISI 302, 303, 304, 316, and 17-4 PH grades of Stainless Steel; Chrome Plating; PTFE; Ultra-High Molecular Weight Polyethylene

Technical Data (5:1 Monark)

Fluid Outlet Pressure Chart

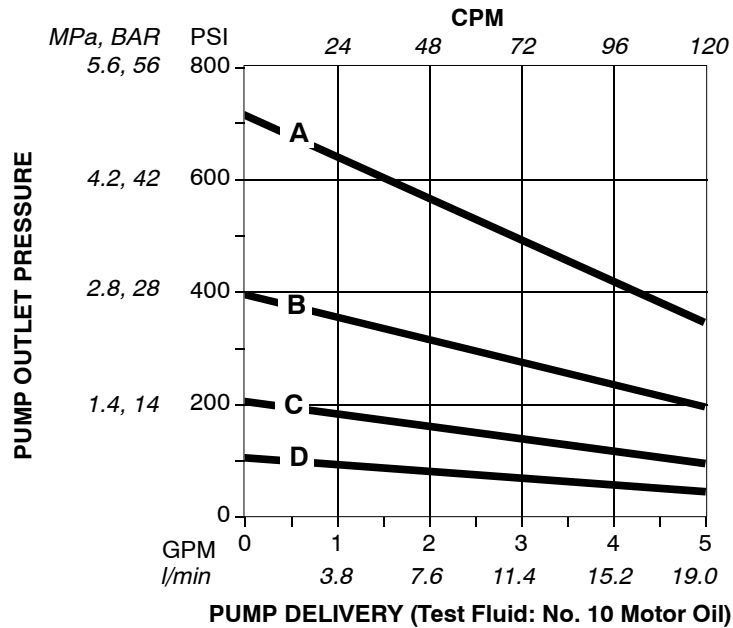

- A 1.25 MPa, 12.5 bar (180 psi) air pressure
- B 0.7 MPa, 7 bar (100 psi) air pressure
- C 0.49 MPa, 4.9 bar (70 psi) air pressure
- D 0.28 MPa, 2.8 bar (40 psi) air pressure

To find Outlet Pressure (MPa/bar/psi) at a specific delivery (liter/min or gpm) and operating air pressure (MPa/bar/psi):

1. Locate desired delivery along bottom of chart.
2. Read vertical line up to intersection with selected fluid outlet pressure curve. Curve slopes from left to right. Follow left to scale and read outlet pressure.

Air Consumption Chart

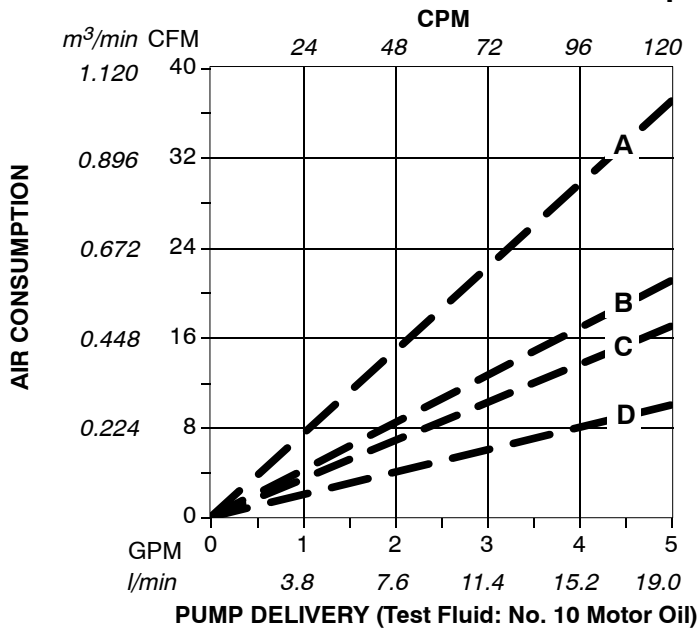

- A 1.25 MPa, 12.5 bar (180 psi) air pressure
- B 0.7 MPa, 7 bar (100 psi) air pressure
- C 0.49 MPa, 4.9 bar (70 psi) air pressure
- D 0.28 MPa, 2.8 bar (40 psi) air pressure

To find Pump Air Consumption (m³/min or CFM/min) at a specific delivery (liter/min or gpm) and operating air pressure (MPa/bar/psi):

1. Locate desired delivery along bottom of chart.
2. Read vertical line up to intersection with selected air consumption curve. Curve slopes from right to left. Follow left to scale and read air consumption.

Dimensions

Model 224348 Shown

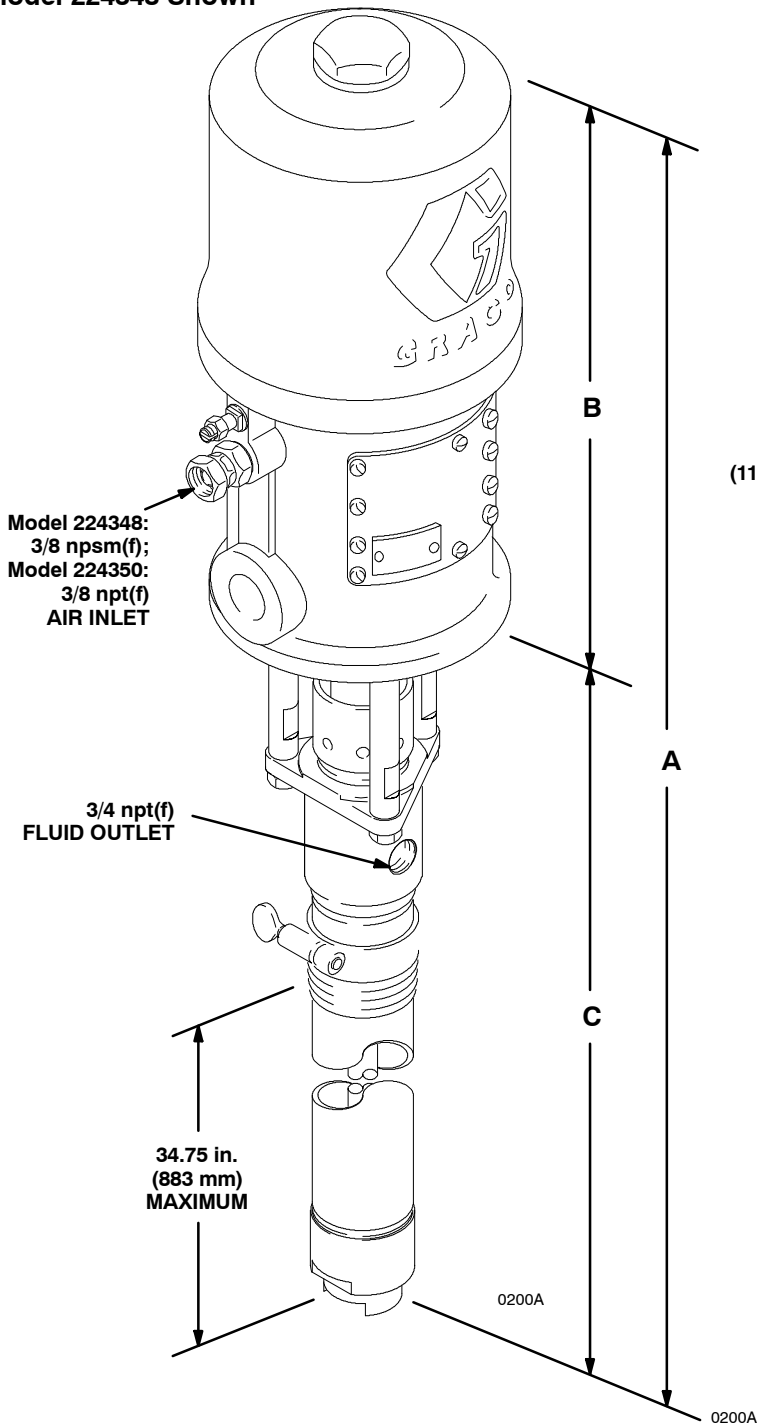

Mounting Hole Layout

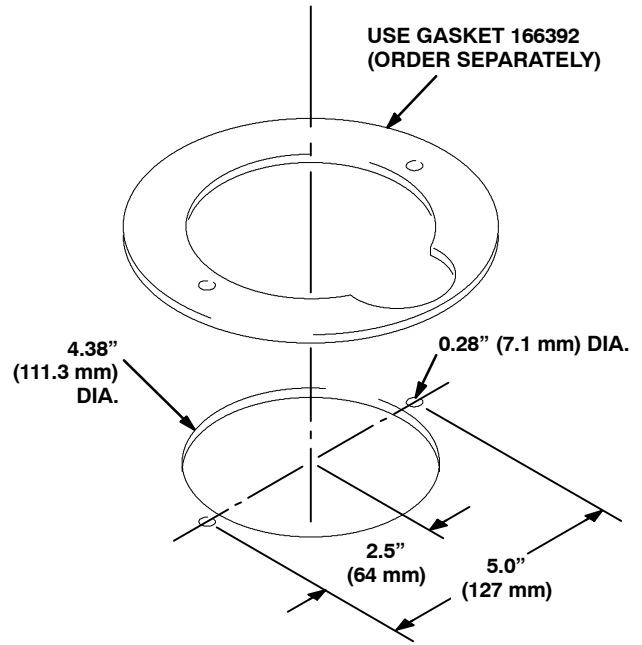

Pump Model	A	B	C
224348	57.31 in. (1456 mm)	14.63 in. (372 mm)	42.68 in. (1084 mm)
256713	58.19 in. (1478 mm)	14.63 in. (372 mm)	43.56 in. (1106 mm)
224350	54.28 in. (1379 mm)	11.60 in. (295 mm)	42.68 in. (1084 mm)
256714	55.16 in. (1401 mm)	11.60 in. (295 mm)	43.56 in. (1106 mm)

Graco Standard Warranty

Graco warrants all equipment manufactured by Graco and bearing its name to be free from defects in material and workmanship on the date of sale to the original purchaser for use. With the exception of any special, extended, or limited warranty published by Graco, Graco will, for a period of twelve months from the date of sale, repair or replace any part of the equipment determined by Graco to be defective. This warranty applies only when the equipment is installed, operated and maintained in accordance with Graco's written recommendations.

This warranty does not cover, and Graco shall not be liable for general wear and tear, or any malfunction, damage or wear caused by faulty installation, misapplication, abrasion, corrosion, inadequate or improper maintenance, negligence, accident, tampering, or substitution of non-Graco component parts. Nor shall Graco be liable for malfunction, damage or wear caused by the incompatibility of Graco equipment with structures, accessories, equipment or materials not supplied by Graco, or the improper design, manufacture, installation, operation or maintenance of structures, accessories, equipment or materials not supplied by Graco.

This warranty is conditioned upon the prepaid return of the equipment claimed to be defective to an authorized Graco distributor for verification of the claimed defect. If the claimed defect is verified, Graco will repair or replace free of charge any defective parts. The equipment will be returned to the original purchaser transportation prepaid. If inspection of the equipment does not disclose any defect in material or workmanship, repairs will be made at a reasonable charge, which charges may include the costs of parts, labor, and transportation.

THIS WARRANTY IS EXCLUSIVE, AND IS IN LIEU OF ANY OTHER WARRANTIES, EXPRESS OR IMPLIED, INCLUDING BUT NOT LIMITED TO WARRANTY OF MERCHANTABILITY OR WARRANTY OF FITNESS FOR A PARTICULAR PURPOSE.

Graco's sole obligation and buyer's sole remedy for any breach of warranty shall be as set forth above. The buyer agrees that no other remedy (including, but not limited to, incidental or consequential damages for lost profits, lost sales, injury to person or property, or any other incidental or consequential loss) shall be available. Any action for breach of warranty must be brought within two (2) years of the date of sale.

Graco makes no warranty, and disclaims all implied warranties of merchantability and fitness for a particular purpose in connection with accessories, equipment, materials or components sold but not manufactured by Graco. These items sold, but not manufactured by Graco (such as electric motors, switches, hose, etc.), are subject to the warranty, if any, of their manufacturer. Graco will provide purchaser with reasonable assistance in making any claim for breach of these warranties.

In no event will Graco be liable for indirect, incidental, special or consequential damages resulting from Graco supplying equipment hereunder, or the furnishing, performance, or use of any products or other goods sold hereto, whether due to a breach of contract, breach of warranty, the negligence of Graco, or otherwise.

FOR GRACO CANADA CUSTOMERS

The parties acknowledge that they have required that the present document, as well as all documents, notices and legal proceedings entered into, given or instituted pursuant hereto or relating directly or indirectly hereto, be drawn up in English. Les parties reconnaissent avoir convenu que la rédaction du présente document sera en Anglais, ainsi que tous documents, avis et procédures judiciaires exécutés, donnés ou intentés à la suite de ou en rapport, directement ou indirectement, avec les procédures concernées.

Graco Information

For the latest information about Graco products, visit www.graco.com. For patent information, see www.graco.com/patents.

TO PLACE AN ORDER, contact your Graco distributor or call to identify the distributor closest to you:

Phone: 612-623-6921 or **Toll Free:** 1-800-328-0211 **Fax:** 612-378-3505

All written and visual data contained in this document reflects the latest product information available at the time of publication. Graco reserves the right to make changes at any time without notice.

Original instructions. This manual contains English. MM 308118

Graco Headquarters: Minneapolis
International Offices: Belgium, China, Japan, Korea

GRACO INC. AND SUBSIDIARIES • P.O. BOX 1441 • MINNEAPOLIS, MN 55440-1441 • USA
Copyright 1991, Graco Inc. All Graco manufacturing locations are registered to ISO 9001.

www.graco.com
Revised February 2021