

# Instructions – Parts List



## KING HYDRA-CAT<sup>®</sup> FIXED RATIO Proportioning Pumps

308226K

EN

*3000 psi (21 MPa, 210 bar) Maximum Working Pressure*

**Three Displacement Pump Models  
in Various Mix Ratios, Pressure Ratios,  
and Flow Volume**

**Available as Bare Pumps, or as  
Wall-Mounted\* or Free-Standing\* Models**

\*Includes Mixing Manifolds, Automatic Pressure Relief Valves, Check Valves, Pressure Gauges, and Regulators

For models that are  certified  
see page 5.



**Read warnings and instructions.**  
See page 2 for table of contents.

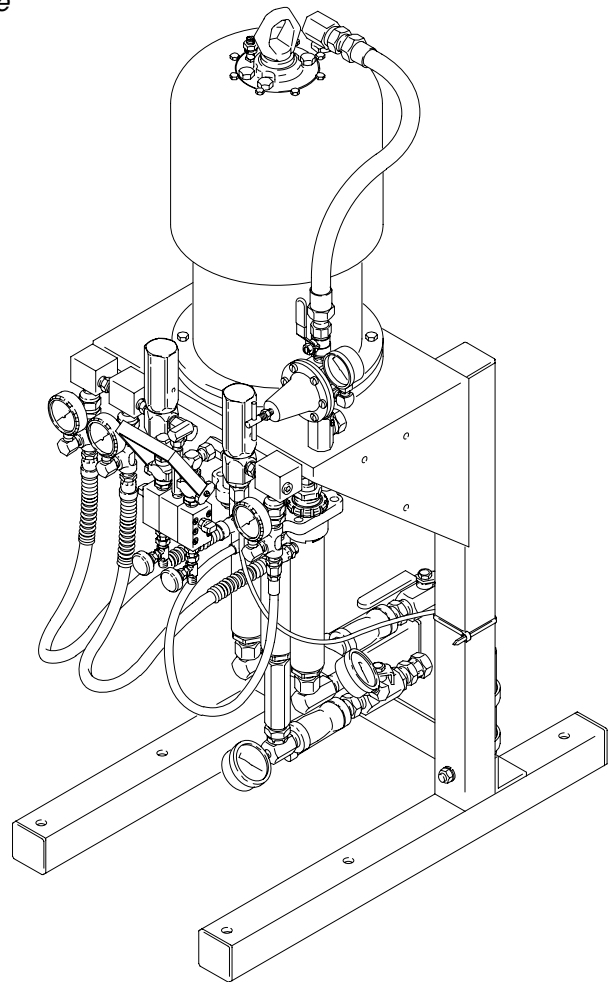

02922A

# Table of Contents

Warnings	2
Model Chart	5
Typical Installation	6
Installation	7
Installation – Optional Fluid Heaters	10
Installation – Optional Solvent Pump	12
Flushing	14
Operation	16
Shutdown and Care of the System	19
Troubleshooting	20
Service – Displacement Pump	22
Parts – Bare, Three Pumps	24
Parts – Wall Mount, Three Pumps	26
Parts – Stand Mount, Three Pumps	28
Accessories	30
Dimensions	33
Mounting Hole Layout for Air Motor	33
Technical Data	34
Graco Warranty	36
Graco Information	36

# Symbols

## Warning Symbol



This symbol alerts you to the possibility of serious injury or death if you do not follow the instructions.

## Caution Symbol



This symbol alerts you to the possibility of damage to or destruction of equipment if you do not follow the instructions.

# WARNING



INSTRUCTIONS

## EQUIPMENT MISUSE HAZARD

Equipment misuse can cause the equipment to rupture or malfunction and result in serious injury.

- This equipment is for professional use only.
- Read all instruction manuals, tags, and labels before operating the equipment.
- Use the equipment only for its intended purpose. If you are not sure, call your Graco distributor.
- Do not alter or modify this equipment. Use genuine Graco parts and accessories.
- Check equipment daily. Repair or replace worn or damaged parts immediately.
- Do not exceed the maximum working pressure stated on the equipment or in the **Technical Data** for your equipment. Do not exceed the maximum working pressure of the lowest rated component in your system.
- Use fluids and solvents which are compatible with the equipment wetted parts. Refer to the **Technical Data** section of all equipment manuals. Read the fluid and solvent manufacturer's warnings.
- Handle hoses carefully. Do not pull on hoses to move equipment.
- Route hoses away from traffic areas, sharp edges, moving parts, and hot surfaces. Do not expose Graco hoses to temperatures above 66°C (150°F) or below -40°C (-40°F).
- Wear hearing protection when operating this equipment.
- Do not move or lift pressurized equipment.
- Comply with all applicable local, state, and national fire, electrical, and safety regulations.

# WARNING

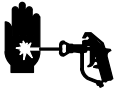

## INJECTION HAZARD

Spray from the valve, leaks or ruptured components can inject fluid into your body and cause extremely serious injury, including the need for amputation. Fluid splashed in the eyes or on the skin can also cause serious injury.

- Fluid injected into the skin is a serious injury. The injury may look like just a cut, but it is a serious injury. Get immediate medical attention.
- Do not point the valve at anyone or at any part of the body.
- Do not put your hand or fingers over the valve tip.
- Do not stop or deflect leaks with your hand, body, glove or rag.
- Do not “blow back” fluid; this is not an air spray system.
- Always have the tip guard and the trigger guard on the valve when spraying.
- Be sure the valve trigger safety operates before dispensing.
- Lock the valve trigger safety when you stop dispensing.
- Follow the **Pressure Relief Procedure** on page 19 if the spray tip clogs and before cleaning, checking or servicing the equipment.
- Tighten all fluid connections before operating the equipment.
- Check the hoses, tubes, and couplings daily. Replace worn, damaged, or loose parts immediately. Permanently coupled hoses cannot be repaired; replace the entire hose.



## MOVING PARTS HAZARD

Moving parts, such as the air motor piston, can pinch or amputate your fingers.

- Keep clear of all moving parts when starting or operating the pump.
- Keep hands and fingers away from the piston during operation and whenever the pump is charged with air.
- Before checking or servicing the equipment, follow the **Pressure Relief Procedure** on page 19 to prevent the equipment from starting unexpectedly.

# WARNING



## FIRE AND EXPLOSION HAZARD

Improper grounding, poor ventilation, open flames or sparks can cause a hazardous condition and result in a fire or explosion and serious injury.



- Ground the equipment and the object being sprayed. Refer to **Grounding the Pump** on page 7.
- If there is any static sparking or you feel an electric shock while using this equipment, **stop spraying immediately**. Do not use the equipment until you identify and correct the problem.
- Provide fresh air ventilation to avoid the buildup of flammable fumes from solvents or the fluid being sprayed.
- Keep the spray area free of debris, including solvent, rags, and gasoline.
- Before operating this equipment, electrically disconnect all equipment in the spray area.
- Before operating this equipment, extinguish all open flames or pilot lights in the spray area.
- Do not smoke in the spray area.
- Do not turn on or off any light switch in the spray area while spraying or while operating if fumes are present.
- Do not operate a gasoline engine in the spray area.



## TOXIC FLUID HAZARD

Hazardous fluid or toxic fumes can cause serious injury or death if splashed in the eyes or on the skin, inhaled, or swallowed.

- Know the specific hazards of the fluid you are using.
- Store hazardous fluid in an approved container. Dispose of hazardous fluid according to all local, state and national guidelines.
- Always wear protective eyewear, gloves, clothing and respirator as recommended by the fluid and solvent manufacturer.



## PLURAL COMPONENT MATERIALS HAZARD

Graco, Inc. does not manufacture or supply any of the reactive chemical materials that may be used in this equipment and is not responsible for their effects. Because of the vast number of chemicals that could be used and their varying chemical reactions, before using this equipment, the buyer and the user should determine all facts relating to the materials used, including any of the potential hazards involved. Particular inquiry and investigation should be made into the potential dangers relating to toxic fumes, fires, explosions, reaction times, and exposure of human beings to the individual components or their resultant mixtures. Graco assumes no responsibility for loss, damage, expense, or claims for bodily injury or property damage, direct or consequential, arising from the use of such chemical components.

# Model Chart

## Pressure and Ratio Ratings for King Pumps

### WARNING

To reduce the risk of over pressurizing a component, which can result in an explosion and serious injury, never operate the system at a working pressure higher than the lowest rated component in the system. All fluid side components such as dispensing valves, regulators and hoses must have a working pressure equal to or greater than the pressure given in Column B for each pump model.

Column A gives the **maximum** fluid pressure developed at 100 psi (0.7 MPa, 7 bar) of incoming air pressure. Column B gives the **minimum** working pressure required for all system components, based on the automatic relief valve settings. Components included by Graco with the models listed meet or exceed this requirement.

### Models with Three Displacement Pumps

Mix Ratio	Model No.			A			B			Normal Pressure Ratio (Fluid to Air)	Nominal Flow Volume @ 40 cpm	
				Maximum Pump Fluid Pressure at 100 psi (0.7 MPa, 7 bar) Air			Minimum Component Working Pressure					
	Bare	Wall	Stand	psi	MPa	bar	psi	MPa	bar		gpm	lpm
1.67:1	*231666	231284	231289	2989	21	209	3600	25	248	33.21	3.77	14.3
2:1	*231667	231285	231290	2657	18	186	2900	20	200	29.52	4.24	16.1
4:1	231668	231286	231291	3189	22	223	3600	25	248	35.43	3.53	13.4

\*This model is  certified.

# Typical Installation

## About the Typical Installations

These pumps are designed to be part of a Hydra-Cat dispensing system that will proportion, mix, and dispense two-component fluids. The typical installation is only a guideline to setting up a complete proportioning system. For clarity, various components are shown in the correct order but may not be shown in exactly the position of the installed system. For assistance in designing your system, contact your nearest Graco distributor.

**NOTE:** When pressure feeding the proportioning pump, mount fluid pressure gauges (J) at the proportioning pump inlets to monitor proper adjustment of the feed pump pressures. Never exceed 25% of the Hydra-Cat pump outbound fluid pressure on the feed supply.

## Heavy Viscosity Heated System Three Displacement Pumps, 10:1 Ratio Feed Pumps

### KEY

A	Bleed-type master air valve	H	Proportioning pump	Q	Fluid shutoff valve
B	Air filter	J	Fluid pressure gauge	R	Static mixer
C	Air lubricator	K	Check valve	S	Dispense valve
D	Pump runaway valve	L	Automatic pressure relief valve	T	Fluid regulator
E	Pump air regulator	M	Fluid filter	U	Solvent pump
F	Feed pump	N	Mixer manifold	V	Fluid strainer
G	Ground wire	P	Fluid drain valve	W	Fluid heater
		X	Supply manifold		

1 See note above

2 Connect to drain bottle.  
See Fig. 4, page 8

\* Included with wall or stand models

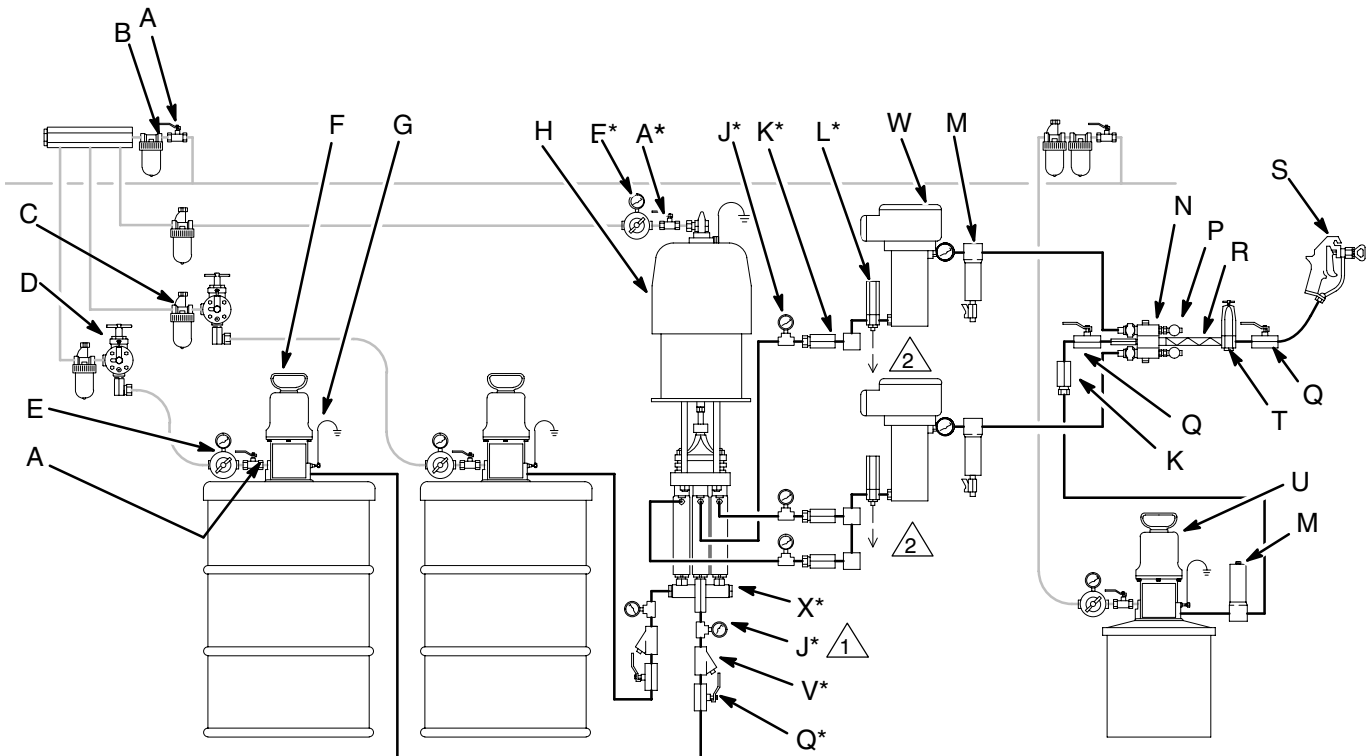

Fig. 1

02923

# Installation

## Bare Pumps

Bare pumps are available for those installations which require a highly customized system. For a safe and efficient system, Graco recommends that the air and fluid components supplied with the Wall Mount and Cart Mount models also be used in customized systems. Refer to the Parts Drawings on pages 24–29 for part numbers. In addition, the accessories shown in the Typical Installation drawings and discussed in the following pages of this manual should be used.

Be sure all accessories are sized properly for the air and fluid requirements of your system.

Read all instructions in the Installation section for further details.

### NOTES:

1. Models with three displacement pumps always use the two outer displacement pumps to supply the resin and the middle displacement pump to supply the hardener.
2. Label all pumps, hoses, fluid regulators, etc. to indicate whether they are for the resin side or hardener side of the system.

## Mounting the Pump

Mount the pump to suit your installation. The bare pump can be mounted on a wall bracket or on a cart. See the Mounting Hole Layout on page 33. The King pump and accessories weigh approximately 125 lb (55 kg). The pump stand and accessories weigh 55 lb (25 kg).

For a wall mount, be sure the bracket and wall are strong enough to support the pump, accessories, plumbing and stress caused by pump operation. Locate the bracket about 5 ft (1.5 m) above the floor.

## Grounding the Pumps

**⚠ WARNING**

**FIRE AND EXPLOSION HAZARD**  
Before operating the pump, ground the system as explained below. Also read the section **FIRE AND EXPLOSION HAZARD** on page 4.

Use a ground wire and clamp. See Fig. 2. Remove the ground screw (Z) and insert through eye of ring terminal at the end of ground wire (G). Fasten ground screw back onto pump and tighten securely. Connect the other end of ground wire to a true earth ground. Order Part No. 222011 Ground Wire and Clamp.

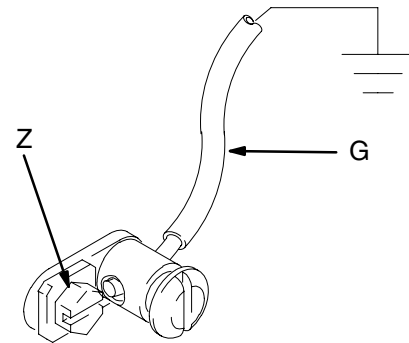

**Fig. 2**

TI1052

# Installation

## Air Control Accessories

Install the accessories in the order shown in Fig. 3. Mount only the air regulator (E) and a master air valve (A) at the pump. Mount all other accessories on separate wall brackets to reduce stress on the pump inlet. Note that one air filter (B) can serve multiple pumps by using an air manifold downstream from the air filter.

### ! WARNING

Bleed-type master air valves (A) are required in the system in the positions shown in the Typical Installation drawings. These valves are used during system pressure relief to relieve air trapped in the air line. Trapped air can cause the pump to cycle unexpectedly and result in serious injury from moving parts, fluid injection, or fluid splashing.

1. Install a bleed-type master air valve (A) in the pump air inlet.
2. Install an air regulator and gauge (E) to control pump outlet pressure.
3. Install a pump runaway valve (D) for each feed pump to automatically shut off the air to the pump if the pump accelerates beyond the pre-adjusted setting. A pump which runs too fast can be seriously damaged.
4. Install an air line lubricator (C) for automatic air motor lubrication.
5. Install an air filter (B) to remove harmful dirt and moisture from the compressed air supply.

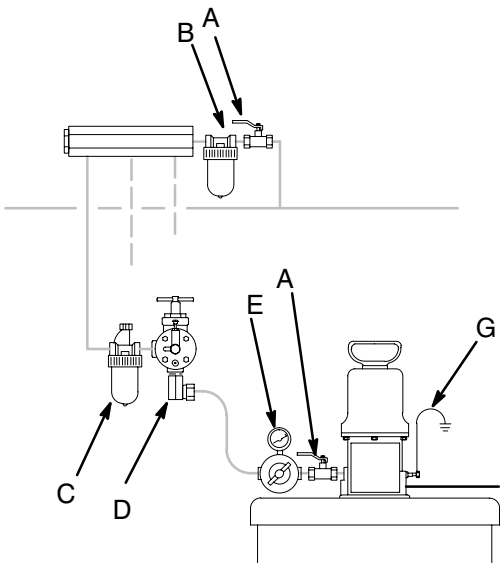

Fig. 3 02887

## Automatic Pressure Relief Valves

### ! WARNING

To reduce the risk of component rupture, which could cause serious injury and property damage, the appropriate automatic pressure relief valve is **required** for each fluid on a plural component pump.

These valves automatically relieve fluid pressure if the pump output pressure exceeds the valve's preset pressure. Over pressurization may occur if there is a fluid line clog upstream from the valve or if any other condition exists that causes one of the pumps to cavitate and direct all fluid pressure to the other pump(s).

See the Model Chart on page 5 to determine the preset pressure in your system.

Two drainage bottle kits (38) are included with wall models (unassembled) and stand mount models (assembled) to catch the drainage if the automatic pressure relief valves open.

For the wall mount models, assemble the kit as shown in Fig. 4 and mount it securely to a wall or bracket. Use the tie wrap, supplied, to hold the hoses out of the way, if necessary.

### ! WARNING

Fluid emitted from the automatic pressure drain valves may be at pressures over 3000 psi (21 MPa, 210 bar). Make sure the drain bottles are securely fastened to the frame or wall so that they can handle a sudden spurt of pressurized fluid.

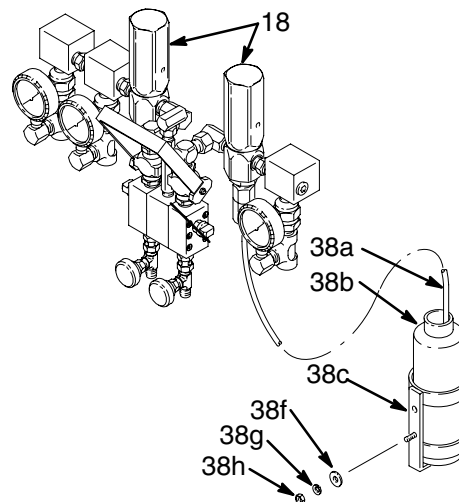

Fig. 4 02888A



# Installation

**NOTE:** If you mount the pump on a wall, turn the displacement pump inlet assemblies (CC) to face forward, rather than backwards as shown in Fig. 5.

## Connect Fluid Supply Hoses

1. Connect the resin supply hose (EE) to the 3/4 npt swivel inlet (37B) for the resin displacement pumps. See Fig. 5.
2. Connect the hardener supply hose (DD) to the 3/4 npt swivel inlet (37) for the center (hardener) displacement pump. See Fig. 5.

## Additional System Components

Install and connect the feed pumps, solvent pump, heaters, etc. Refer to the Typical Installation (Fig. 1) and Accessories on pages 30 and 31 for parts information.

Use a dry air kit or a nitrogen regulator kit to protect the fluid in the supply containers from moisture that can crystallize the fluid and cause the ball checks to malfunction. See Accessories on page 31.

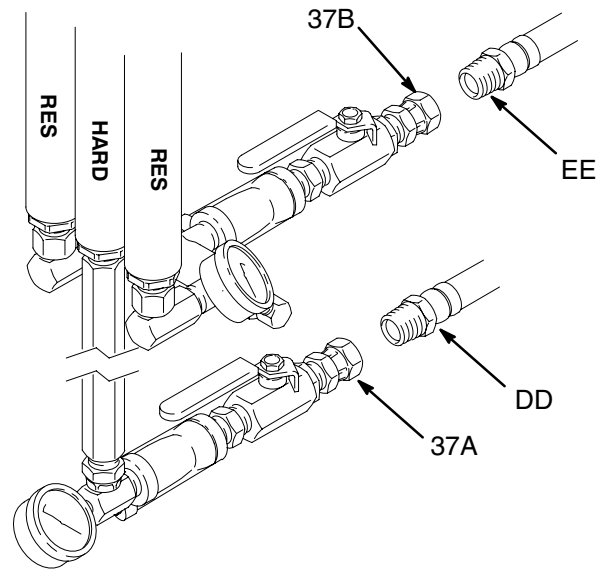

**Fig. 5**

02890

# Installation – Optional Fluid Heaters

## All Models

**NOTE:** For systems requiring one heater for each fluid, see page 30 to order the heaters and required plumbing (items 201 to 205).

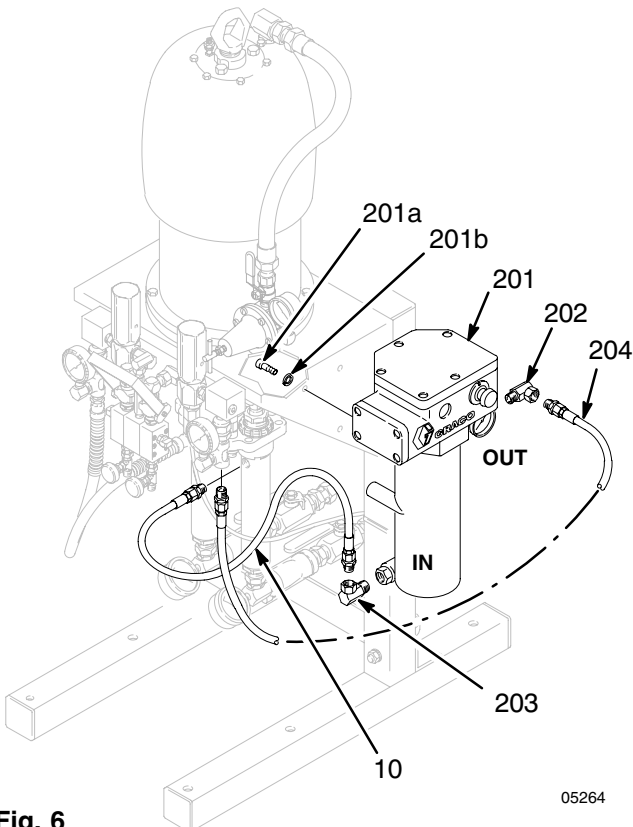

Fig. 6

05264

## ⚠ WARNING

To reduce the risk of serious injury, follow the **Pressure Relief Procedure** on page 19 before installing the heaters.

1. Mount a heater to each side of the mounting bracket using the three screws (201a) and lock-washers (201b) supplied with each heater. See Fig. 6.
2. Connect a swivel union (202) to the outlet of each heater. See Fig. 6.
3. Connect a swivel union (203) to the inlet of each heater. See Fig. 6.

## For Two Displacement Pump Models

1. Disconnect the existing hardener hose (10B) from the inlet of the mixer manifold (23). See Fig. 6. Connect the free end of the hose to the swivel (203) at the hardener heater inlet. See Fig. 7.
2. Install a new fluid hose (204B) between the hardener heater outlet (202B) and the hardener mixer manifold. See Fig. 6 and 7.
3. Repeat Steps 1 and 2 for the resin pump (the “A” side).

See Three Displacement Pump Models on next page.

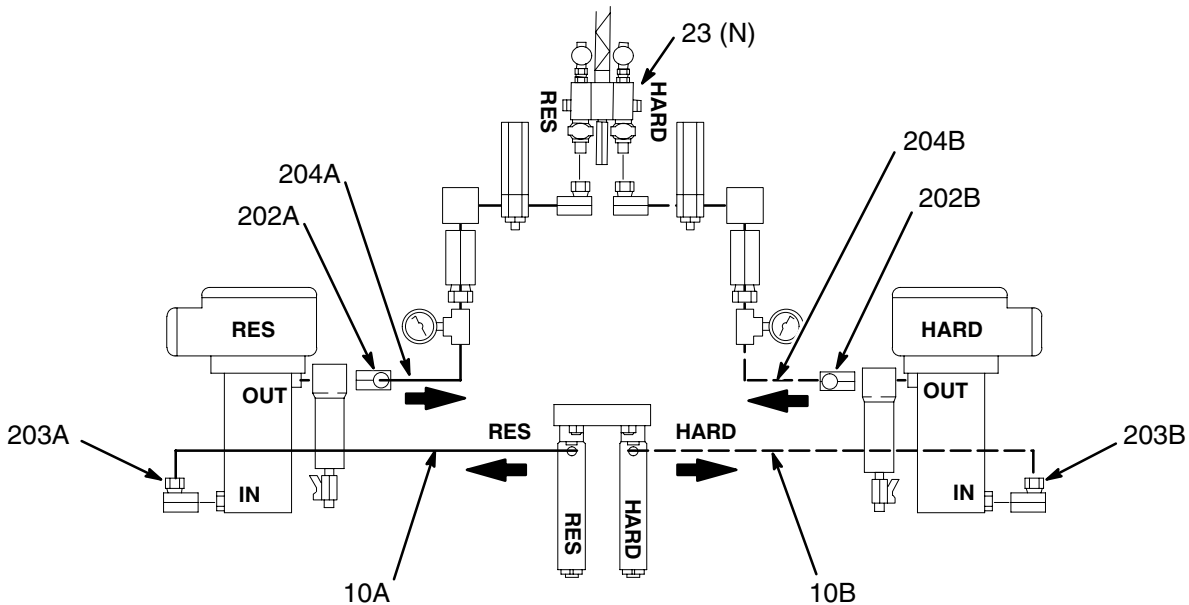

Fig. 7

02893

# Installation – Optional Fluid Heaters

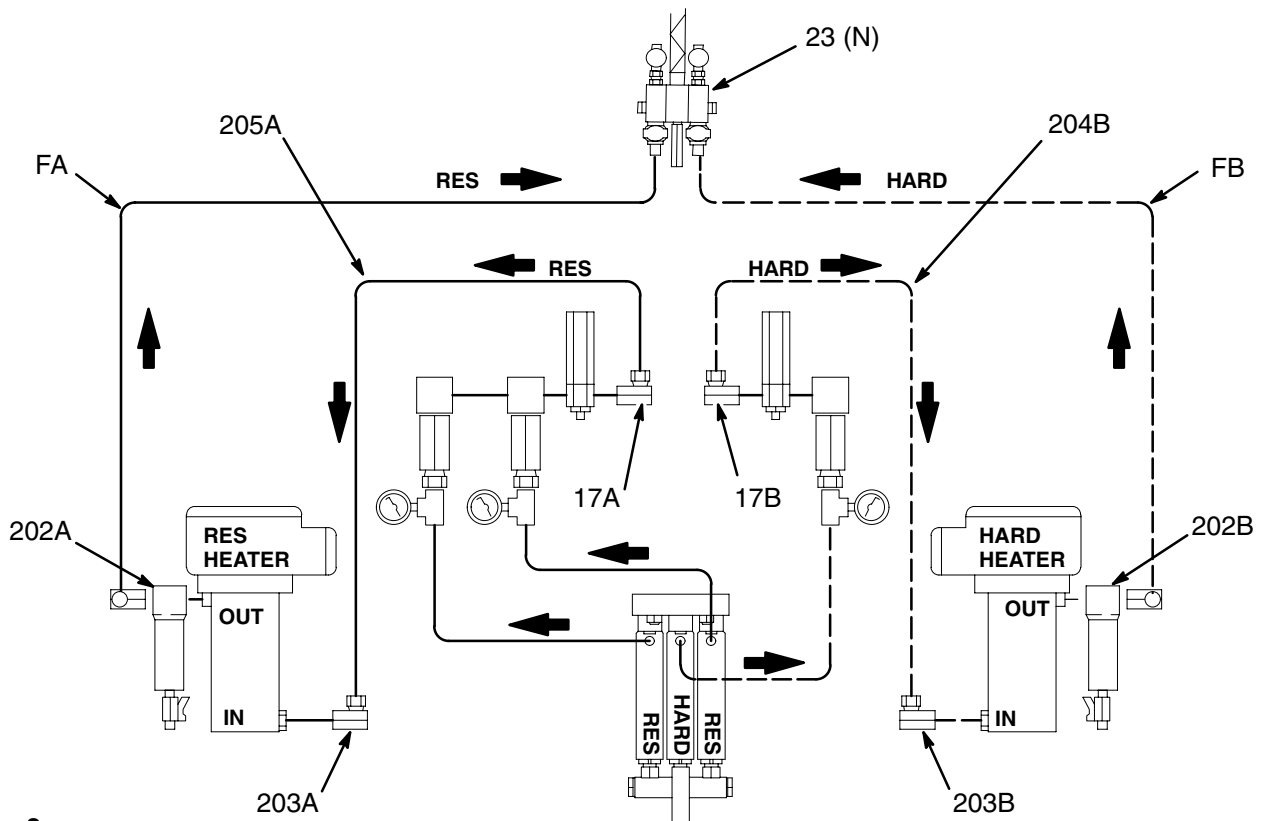

Fig. 8

02894

## For Three Displacement Pump Models

**NOTE:** You must provide two hoses (FA, FB in Fig.8) and fittings to run from the heater outlets to the mixer manifold inlets.

**NOTE:** To accommodate two resin fluid hoses, the mixer manifold (23) must be disconnected from the bracket and mounted remotely.

1. Loosen the swivel of the unions (17A, 17B) to remove the elbow (16A, 16B) on each side of the mixer manifold (23). Turn the unions (17A, 17B) so the outlet faces up. See Fig. 8 and 9.
2. Connect a new hardener fluid hose (204B) between the union (17B) and the swivel (203B) at the heater inlet. See Fig. 8.
3. Install another hardener fluid hose (FB) between the heater outlet elbow (202B) and the hardener side of the mixer manifold (23). See Fig. 8.
4. Repeat Steps 1 to 3 for the resin side of the system (the "A" side).

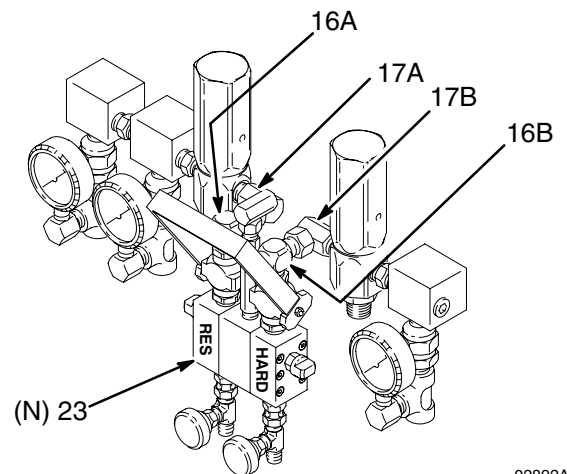

Fig. 9

02892A

# Installation – Optional Solvent Pump

**NOTE:** The optional solvent pump is not offered as a kit; order parts as needed. The optional parts shown here are listed on page 31. These instructions assume that the pump is being mounted to the back of the stand offered in this manual. The Typical Installation on page 6 shows an alternate installation. Adjust your installation according to your specific needs.

1. Mount the solvent pump bracket (301) on the back of the stand.
2. Mount the pump (306) to the bracket using the hardware supplied with the pump.
3. Use the existing proportioning pump air regulator (5) to supply air to the solvent pump. Remove the plug from the back of the swivel union (3) and install the adapter (301). Rotate the regulator gauge elbow (4) so the gauge is facing the operator.
4. Couple the hose (303) and couplings (302). Connect the hose (303) to the adapter (301).
5. Install the other adapter (301), needle valve (304) and adapter (305) to the pump inlet.
6. Connect the adapter (307), elbow (308) and fluid hose (309) to the pump outlet.
7. Install a fluid shutoff valve (311) at the mixer manifold swivel union (15). This valve is used to prevent resin or hardener from backing up into the solvent system, and to isolate the solvent system for service. Connect the solvent inlet hose (309).
8. Connect the suction hose assembly (312) to the pump intake.

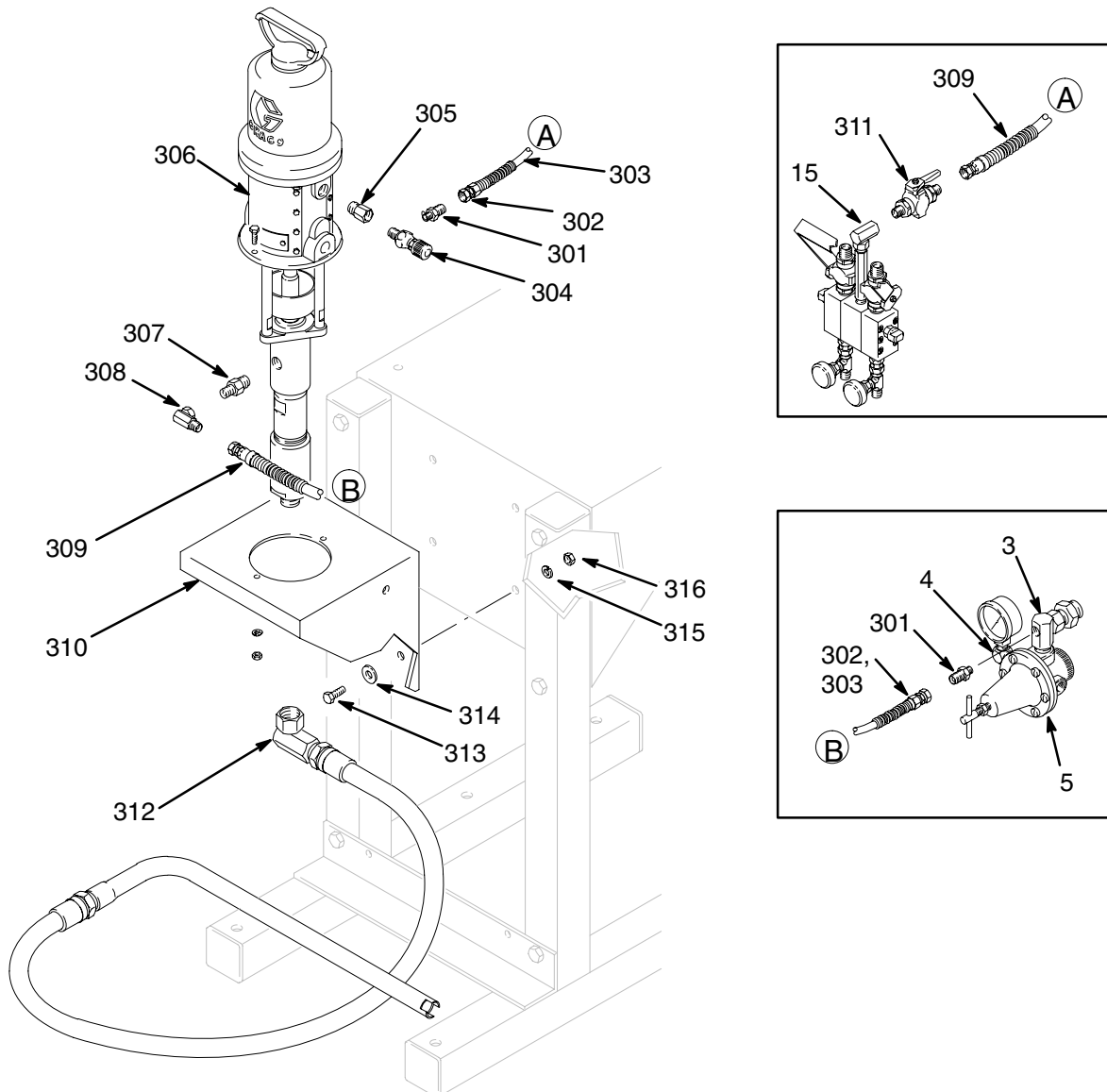

Fig. 10

02902B



# Flushing

## When to Flush the System

- Flush the system before its first use to remove the light oil which was left in after factory testing.
- Flush the manifold mixer (N), using the solvent pump, as frequently during the day as necessary to avoid exceeding the pot life limit of the material being pumped.
- Flush frequently enough during regular operation to prevent clogged passages due to material being overheated or dried out in any part of the system. Clogged passages in the heater can be very difficult to clean and can reduce heating efficiency, flow rate and pressure.
- Flush the entire system when the system is shut down for a long period of time. Keep in mind that some moisture may get into the lines, which could contaminate the hardener, so flush again before restarting the system.

## How to Operate the Mixer Manifold

To open or close the mixer manifold (N) fluid valves (LL) push the handle (KK) down to open and up to close. See Fig. 11.

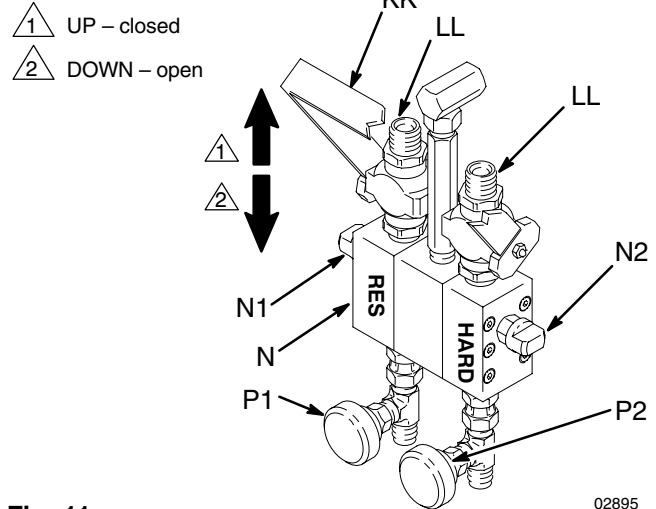

Fig. 11

02895

## KEY

- |    |  |    |                           |    |                              |
|----|--|----|---------------------------|----|------------------------------|
| A  | Bleed-type master air valve                | E  | Pump air regulator        | H  | Proportioning pump           |
| A1 | Hardener feed pump                         | E1 | Hardener feed pump        | N  | Mixer manifold               |
| A2 | Resin feed pump                            | E2 | Resin feed pump           | Q  | Fluid shutoff valve          |
| A3 | Proportioning pump                         | E3 | Proportioning pump        | Q1 | Proportioning pump intake    |
| A4 | Solvent pump                               | E4 | Solvent pump              | Q2 | Mixer manifold solvent inlet |
| A5 | Feed & Proportioning pump master air valve | J  | Fluid pressure gauge      |    |                              |
| A6 | Solvent pump master air valve              | J1 | Proportioning pump intake |    |                              |
|    |  | J2 | Proportioning pump outlet |    |                              |

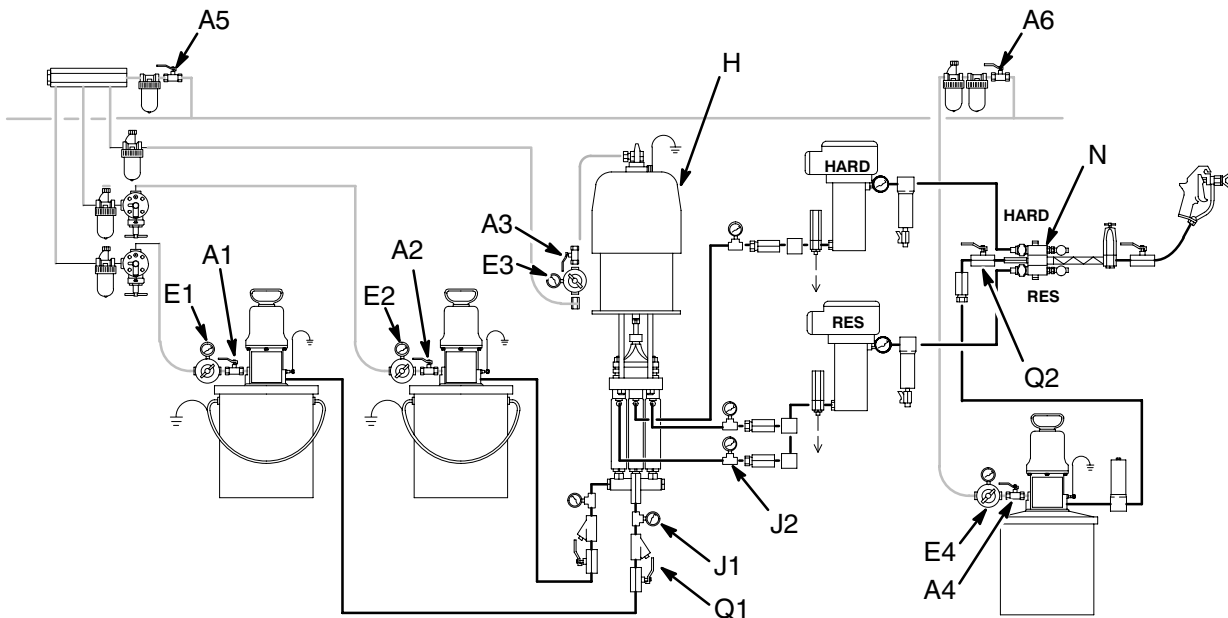

Fig. 12

02924

# Flushing

## How to Flush the System

### **WARNING**

If your system is equipped with heaters, always shut off the main power to the heaters before flushing. Circulate the fluid through the system for at least 10 minutes to cool the fluid and the heater. This reduces the risk of serious injury from burns.

**NOTE:** For the first time flushing, we recommend using mineral spirits solvent (also called white spirit) to flush out the oil. Then flush again using a solvent that is compatible with the fluid you will be dispensing. However, be sure the mineral spirits solvent is compatible with the material you will be pumping. If it is not, check with your fluid supplier to determine an appropriate solvent for flushing out the light oil.

### *For flushing only . . .*

**NOTE:** The proportioning pump is not operated during flushing. The solvent from the feed pumps will flush the proportioning pump displacement pumps.

1. Place each feed pump intake into a separate 5 gallon grounded pail, containing about 3 gallons (12 liters) of solvent.

### *To flush or prime . . .*

2. Be sure both of the fluid shutoff valves (Q1) are open. See Fig. 12.
3. Place a container under the drain valves (P1,P2) of the mixer manifold (N). See Fig. 11.
4. Be sure the feed pump air regulators (E1,E2) are at minimum pressure. See Fig. 12.
5. Open the main master air valve (A5). See Fig. 12.
6. Open the hardener pump master air valve (A1). See Fig. 12.
7. Slowly increase the air regulator (E1) setting until the pump is running slowly.
8. Open the hardener side drain valve (P1). Open the mixer manifold handle (KK). See Fig. 11.
9. When the hardener lines are flushed, close the mixer manifold handle and close the drain valve (P1). Close the air valve (A1). See Fig. 12.
10. Repeat Steps 6 to 9 for the resin feed pump. The resin sides uses these parts: regulator (E2), air valve (A2), drain valve (P2).

### *To flush the solvent valves . . .*

11. Open the hardener solvent flush valve (N1) on the mixer manifold (N). See Fig. 11.
  - a. Be sure the solvent pump air regulator (E4) is at minimum pressure. See Fig. 12.
  - b. Open the solvent pump main master air valve (A6) and then open the pump air valve (A4). See Fig. 12.
  - c. Release the dispensing valve safety latch. Hold the dispensing valve firmly against a grounded pail and trigger it while slowly opening the solvent pump air regulator (E4). Operate the pump slowly until the dispense line is flushed. Release the dispensing valve trigger and engage its safety latch. Close the hardener solvent flush valve (N1).
  - d. Open the resin solvent flush valve (N2) and repeat Step c. See Fig. 11.
  - e. Close the solvent line shutoff valve (Q2). See Fig. 12.

### **CAUTION**

Always close the solvent line fluid shutoff valve (Q2) after the flushing procedure has been completed. This will prevent the other fluids from leaking into the flushing line.

### *If this is a first time flush . . .*

12. Repeat the flushing procedure using a solvent compatible with the fluid you are going to dispense.

### *When you are done flushing . . .*

13. Remove the solvent supply from the feed pumps. Operate the pumps slowly to push all the solvent out of the lines, then stop the pumps.

### *If you are not going to use the system . . .*

14. Close all air regulators, master air valves and fluid shutoff valves. Follow the **Pressure Relief Procedure** on page 19.

### **WARNING**

Always close the air valve (A4) to the solvent pump before opening the fluid drain valves (P2) to relieve system pressure. This will reduce the risk of excessive pressure buildup in the opposite component hose and fittings.

# Operation

## **⚠ WARNING**

### Handling Plural Component Materials

Be extremely cautious when handling plural component materials and solvents used with them. Some are extremely toxic. See the **WARNING** on the front cover. Read and follow the coating and solvent manufacturer's safety precautions and warnings, including information regarding protective clothing, eyewear, and respirators.

When spraying reactive fluids, wear the proper protective clothing, eye protection, gloves, and clean air breathing apparatus as prescribed by the fluid manufacturers recommendations, O.S.H.A. regulations and as approved by N.O.I.S.H. for the chemicals being used.

### Observe the Pot Life Limit

Flush the mixed fluid out of the mixer, dispensing lines and equipment before it hardens. Flush the complete system when necessary to prevent the fluids from hardening in the equipment and hoses. Check the fluid manufacturer's instructions for fluid shelf life, and flush the entire system before this time is reached. Flush the system with a compatible solvent as explained on page 15.

### Fill the Throat Packing Nuts

Keep each displacement pump throat packing nut (JJ) filled with Graco ISO Pump Oil to help prevent fluid from drying on the displacement rod and damaging the pump packings. See Fig. 13.

Verify compatibility of the pump oil with the fluids being used in the pumps. During operation very small amounts of this fluid are dragged past the seals and into the pump.

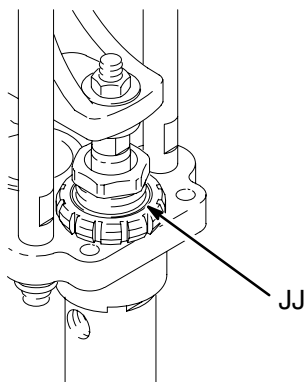

Fig. 13

02897

### Check the Drainage Bottles and Hoses

## **⚠ WARNING**

To reduce the risk of serious injury and property damage, regularly check and clean the drain hose and bottle for the automatic pressure relief valve.

If material is allowed to dry in and clog the drain hose, the automatic pressure relief valve may not fully release the fluid pressure if it opens or may cause the drain hose to burst.

Check the drain hose and bottle (38) at the start of each shift, and whenever there is an imbalance of material, to see if the automatic pressure drain valve has released material into the bottles. Clean the hose and bottle as needed. Regularly check the drain hose for cuts, leaks, or bulges and replace damaged components before using the system. See Fig. 14.

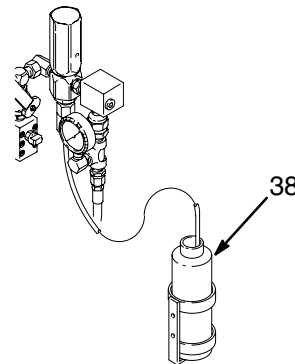

Fig. 14

02948A

### Monitor the Material Supply

## **⚠ CAUTION**

Establish a rigid system for monitoring the material supply to prevent the pumps from running dry. A sudden lack of material in one pump may cause many system problems, including air entrapment, spitting of the fluids, fluid "crossovers", pump damage, downtime, and added system stresses.

Never allow the feed pump or solvent pump containers to run dry. A dry container allows air to be pumped into the system and causes incorrect proportioning. A dry pump will quickly accelerate to a high speed, and may damage itself and the other displacement pump because it causes a pressure rise in the other pump. If a supply container becomes dry, stop the pump immediately, refill the container, and prime the system. Be sure to eliminate all the air from the system.

**NOTE:** The pump runaway valve mentioned on page 8 of the Installation section shuts off the pump if the pump speed accelerates quickly.



# Operation

## Startup

### ⚠ WARNING

To reduce the risk of serious bodily injury, including fluid injection, splashing in the eyes or the skin, and property damage, never exceed the maximum air and fluid working pressure of the lowest rated component in your system. See **Equipment Misuse Hazard**, System Pressure, on page 2.

1. Install full containers of resin and hardener at the feed pumps.
2. To prime the system, follow Steps 2 to 11 of the Flushing procedure on page 15.
3. Turn on the heaters, if used, and allow them to warm up for 10 minutes.
4. Open the feed pump air valves (A1,A2). Adjust the air regulators (E1,E2) just enough to start the pumps operating slowly.
5. Open the proportioning pump air valve (A3) and slowly open the regulator (E3) to start the proportioning pump.
6. Open the mixer manifold (N) and trigger the dispense valve (S).
7. Set the air pressure to the feed pumps at 88 psi (0.6 MPa, 6 bar) or 25% of proportional pressure at the fluid outlets, whichever is less. Use the gauges (J1) to monitor this pressure. Higher pressures may prevent the proportioning pump inlet ball checks from setting properly.
8. Set the air pressure to the proportioning pump (H) to obtain the required fluid pressure. Refer to the proportioning pump chart on page 5 for the fluid to air pressure.
9. While triggering the dispensing valve, check the fluid outlet pressure gauges (J2) and make note of the pressures indicated. Check the gauges frequently during operation. These notes will help to analyze any problems that may occur since a change in displacement pump performance will be indicated by a change in pressure gauge readings.

**NOTE:** A pressure drop does occur during pump stroke changeover.

**NOTE:** Flush the mixer manifold frequently during the day's operation. Follow Step 11 on page 15.

### KEY

A	Bleed-type master air valve	E	Pump air regulator	H	Proportioning pump
A1	Hardener feed pump	E1	Hardener feed pump	N	Mixer Manifold
A2	Resin feed pump	E2	Resin feed pump	S	Dispense Valve
A3	Proportioning pump	E3	Proportioning pump		

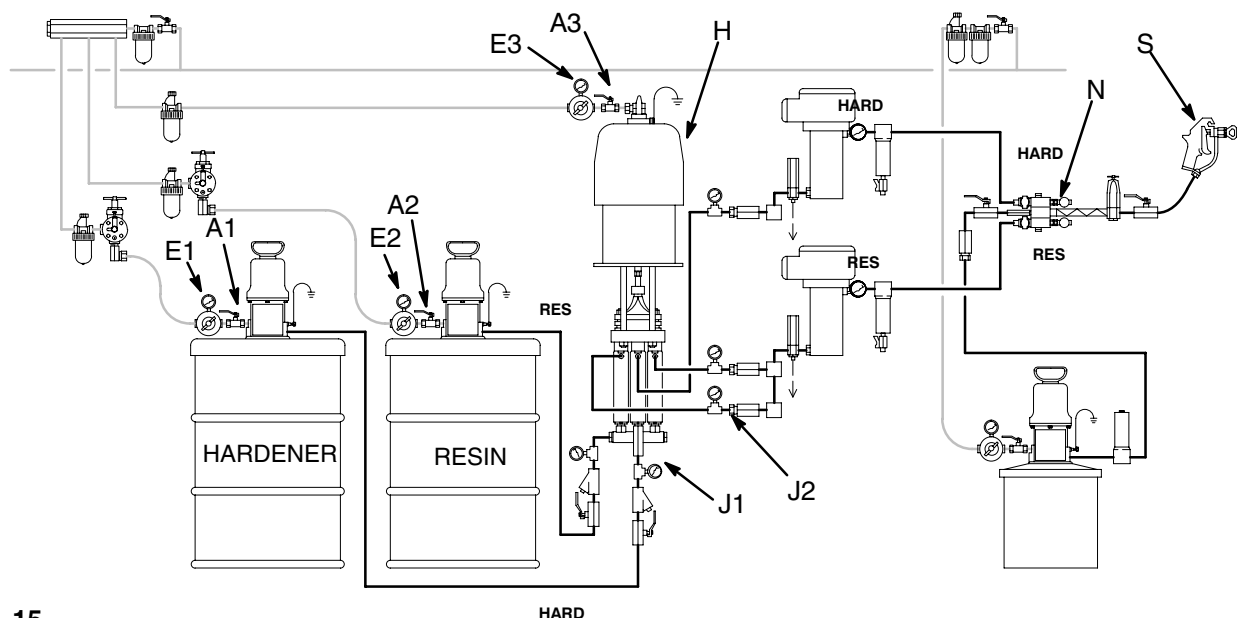

Fig. 15

02923

# Operation

## Checking the Mix Ratio

**NOTE:** Since this is a fixed ratio system, you typically do not have to check the mix ratio.

If the mixed fluid does not cure or harden properly, check the ratio of resin to hardener.

1. Flush the mixer manifold; see Step 11 on page 15.
2. Follow the **Pressure Relief Procedure** on page 19.
3. Open the mixer manifold (N).
4. Set the operating pressure for the pumps. See Steps 7 and 8 on page 17.
5. Release the dispensing valve trigger and engage the safety latch.
6. Close the mixer manifold (N).
7. Open the hardener side drain valve (P2) about three turns. Open the resin side drain valve (P1) about 1 turn. This prevents the pressure from building up on the hardener pump, which would cause the automatic pressure relief valve to open.
8. Place a grounded metal pail under the drain valves.
9. Open the mixer manifold.

10. While observing the pump outlet gauges (J2), adjust the resin and hardener drain valves (P1,P2) until the gauges show your normal operating pressure.

**NOTE:** The pressure must be within 20% of the original spraying pressure to get a usable test.

11. Close the mixer manifold. Put a separate sampling container under each drain valve.
12. Open the mixer manifold to draw a sufficient sample.
13. As you close the mixer manifold, check the pump outlet gauges (J2) again to make sure they are at your normal operating pressure.

**NOTE:** If the fluid pressure is not within 20% of the normal operating pressure, flush the mixer manifold again and take another sample. If the sample ratio is incorrect, refer to the Troubleshooting chart on page 20. If the ratio is correct, the problem is with one of the other system components.

14. Compare the volume of the sampling containers. If the ratio is not correct, refer to the Troubleshooting chart on page 20. If the ratio is correct the problem is one of the other components.
15. Close the drain valves (P1,P2).

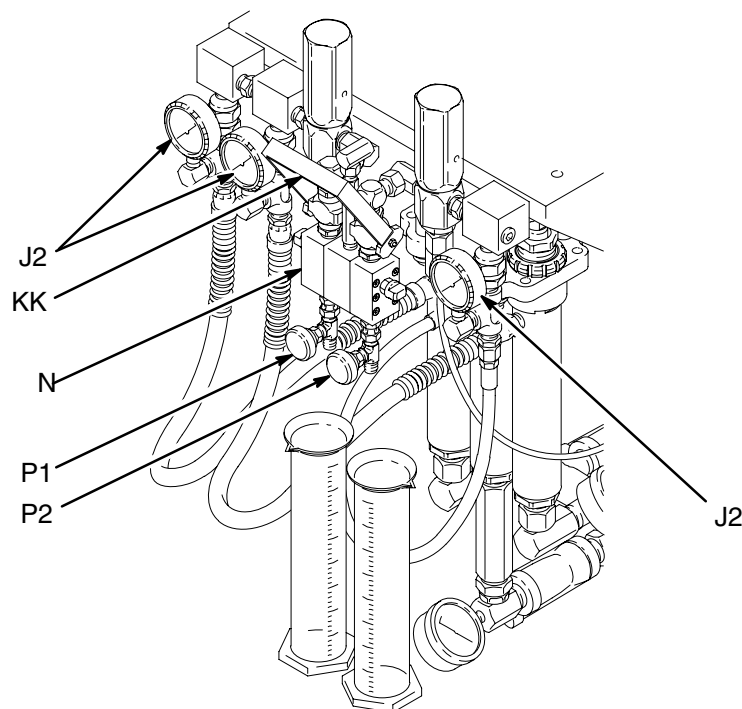

Fig. 16

02898A

# Shutdown and Care of the System

## Pressure Relief Procedure

**⚠ WARNING**

**INJECTION HAZARD**

The system pressure must be manually relieved to prevent the system from starting or spraying accidentally. Fluid under high pressure can be injected through the skin and cause serious injury. To reduce the risk of an injury from injection, splashing fluid, or moving parts, follow the **Pressure Relief Procedure** whenever you:

- are instructed to relieve the pressure,
- stop spraying,
- check or service any of the system equipment,
- or install or clean the spray tips.

1. Engage the dispensing valve safety latch.
2. Shut off the feed pump and proportioning pump air regulators and bleed-type master air valves.
3. If the system has heaters, circulate the fluid for at least 10 minutes to cool the heated fluid and heater.
4. Disengage the dispensing valve safety latch.
5. Hold a metal part of the dispensing valve firmly to the side of a grounded metal pail, and trigger the dispensing valve to relieve pressure.
6. Engage the safety latch.
7. Open the mixer manifold drain valves (required in your system), having a container ready to catch the drainage. Close the valves immediately.
8. Use the solvent pump to flush the mixer manifold valves.

If you suspect that the nozzle or hose is completely clogged, or that pressure has not been fully relieved after following the steps above, very slowly loosen the nozzle or hose end coupling and relieve pressure gradually, then loosen completely. Now clear the nozzle or hose.

## System Shutdown

To shut the system down, shut off the air to all pumps, trigger the dispensing valve into a grounded metal waste container. Close the mixer manifold valves. Flush all the mixed fluid out of the mixer manifold, hoses and dispensing equipment. See page 15. Then follow the **Pressure Relief Procedure**.

## Cleaning the Pump Inlet Strainer

If the fluid pressure from the feed pump to the proportioning pump cannot be maintained on the proportioning pump intake gauge (J), check and clean the strainer (V).

## Care of the Pump Throat Packing Nuts

Keep the throat packing nuts filled with appropriate lubricant and check the tightness of the packing nut weekly. See Fig. 17. The packing nut should be tight enough to prevent leakage; no tighter. Too tight an adjustment causes the packings to bind or wear prematurely and leak. Always follow the **Pressure Relief Procedure** before adjusting the packing nut.

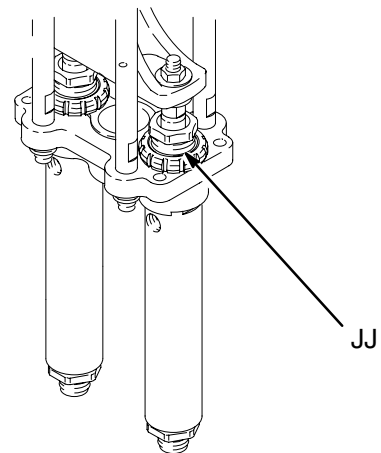

Fig. 17

# Troubleshooting

## ⚠ WARNING

To reduce the risk of serious bodily injury, always follow the **Pressure Relief Procedure** on page 19 whenever you shut off the pump, when checking or servicing any part of the dispensing system, when installing, cleaning or changing fluid tips, and whenever you stop dispensing.

## ⚠ WARNING

Never operate the pump with the air motor plate removed, to reduce the risk of serious bodily injury, including amputation, from moving parts inside the air motor housing.

The chart below is specific to the air motor and pump. Refer to the other instruction manuals with the system to troubleshoot individual components.

This chart uses the proportioner gauges to determine pump malfunctions.

Faulty manifold check valves can mask pump cylinder problems. Always keep these valves operating properly.

Observe the gauge readings during the stroke direction indicated by the bold arrow, and immediately after closing the manifold.

### TROUBLE AREA: RESIN PUMP LEAKAGE

1. THROAT PACKING
2. PISTON PACKING
3. PISTON BALL CHECK

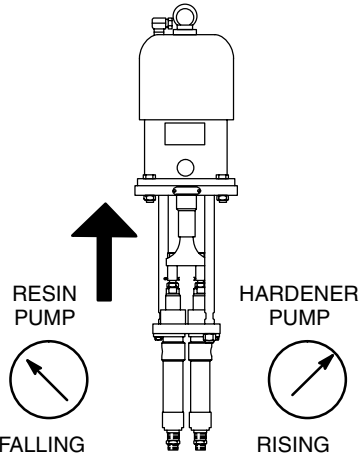

### TROUBLE AREA: HARDENER PUMP LEAKAGE

1. THROAT PACKING
2. PISTON PACKING
3. PISTON BALL CHECK

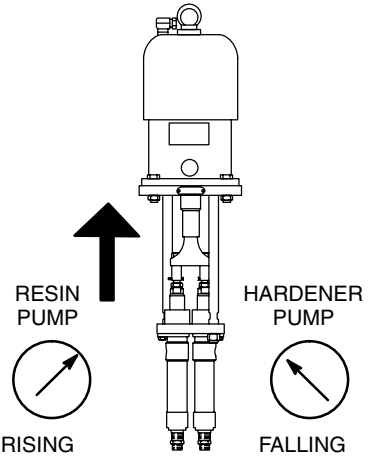

### TROUBLE AREA: RESIN PUMP LEAKAGE

1. THROAT PACKING
2. FOOT VALVE BALL CHECK

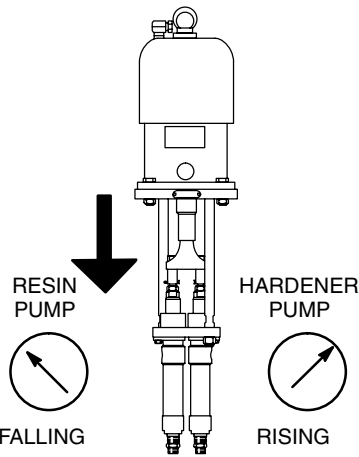

### TROUBLE AREA: HARDENER PUMP LEAKAGE

1. THROAT PACKING
2. FOOT VALVE BALL CHECK

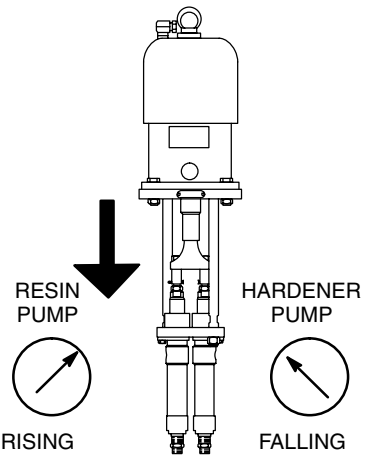

# Troubleshooting

Problem	Cause	Solution
System won't run or stops while running.	Air pressure or volume too low. Closed or restricted air line or air valve. Fluid valves closed. Clogged fluid hose. Air motor worn or damaged.  Displacement pump stuck.	Increase, check air compressor. Open or clean as required. Open fluid valves. Replace fluid hose. Service air motor. <i>See instructions in separate manual 306982.</i> Service pump. <i>See instructions in separate manual 307944.</i>
System speeds up or runs erratically.	Fluid containers are empty.** Air in fluid lines.** Displacement pump parts worn or damaged.	Check often – keep filled. Purge, check connections. Service pump. <i>See instructions in separate manual 307944.</i>
Pump operates but resin output pressure drops during upstroke.*	Dirty, worn or damaged resin pump piston valve. Worn or damaged resin pump piston packings.	Clean, service pump. <i>See instructions in separate manual 307944.</i> Replace.
Pump operates but resin output pressure drops during downstroke.	Dirty, worn or damaged resin pump intake valve.	Clean, service pump. <i>See instructions in separate manual 307944.</i>
Pump operates but resin output pressure drops during both strokes.*	Dirty, worn or damaged resin pump piston valve. Fluid supply low.**	Clean, service pump. <i>See instructions in separate manual 307944.</i> Refill or change container.
Pump operates but hardener output pressure drops during upstroke.*	Dirty, worn or damaged hardener pump intake valve. Worn or damaged hardener pump piston packings.	Clean, service pump. <i>See instructions in separate manual 307944.</i> Replace.
Pump operates but hardener output pressure drops during downstroke.*	Dirty, worn or damaged hardener pump intake valve.	Clean, service pump. <i>See instructions in separate manual 307944.</i>
Pump operates but hardener output pressure drops during both strokes.	Dirty, worn or damaged hardener pump intake valve. Fluid supply low.**	Clean, service pump. <i>See instructions in separate manual 307944.</i> Refill or change container.
Fluid leaks around fluid pump packing nut.	Loose packing nut or worn throat packings.	Tighten, replace.
Relief valve opens too soon or won't close.	Relief valve needs adjusting or is damaged.	Adjust, service pump. <i>See instructions in separate manual 307944.</i>

\* Fluid ratio will be wrong.

\*\* Purge all air out of the system before proportioning the fluids.

# Service – Displacement Pump

## Removal and Replacement

Thoroughly flush the system with a solvent which is compatible to the fluid being pumped, then follow the **Pressure Relief Procedure** on page 19. The Flushing procedure is on page 15.

Stop the pump at the bottom of its stroke.

### CAUTION

If you are changing to a different type of fluid, completely clean all of the equipment and hoses, making sure that no fluid remains in any part of the system.

Remove the fluid outlet hoses from the displacement pumps.

Unscrew the swivel union (33) from the bottom of the center displacement pump. Unscrew the swivel unions (126) from the outer displacement pumps. Remove the supply manifold (125) from the outer pumps. Unscrew the straight union (39) from the center displacement pump. See Fig. 18.

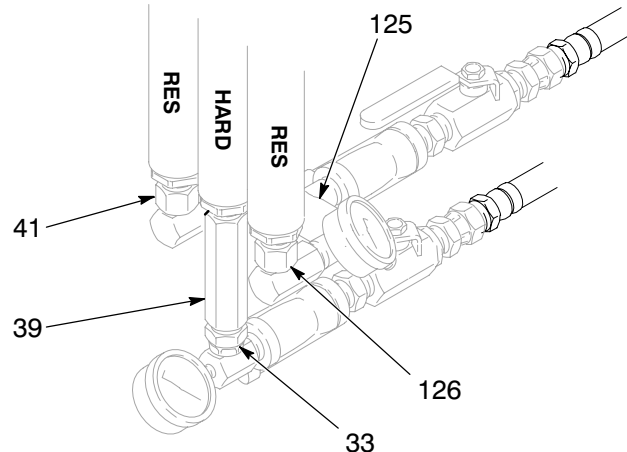

Fig. 18

# Service – Displacement Pump

## Disassembly

1. Remove the locknuts (113) from the top of the yoke (114) of the two outer displacement rods. See Fig. 19. Unscrew the outer locknuts (122) from the top of the tie plate (123) on the two displacement pumps. Use a screwdriver and hammer to loosen.

**NOTE:** The tie rods (111) shown in Fig. 19 are removed from the tie plate (121) for clarity only and do not require removal.

2. Remove the two outer pumps from the tie plate. Remove the washers (115) from the rods of each pump.
3. Using a wrench on the flats of the center pump's displacement rod, screw the rod out of the yoke (114). See Detail B in Fig. 19. Remove the pump from the yoke (114) then the washer (115) from the rod on the pump.
4. Refer to the appropriate instruction manual for servicing the displacement pump.

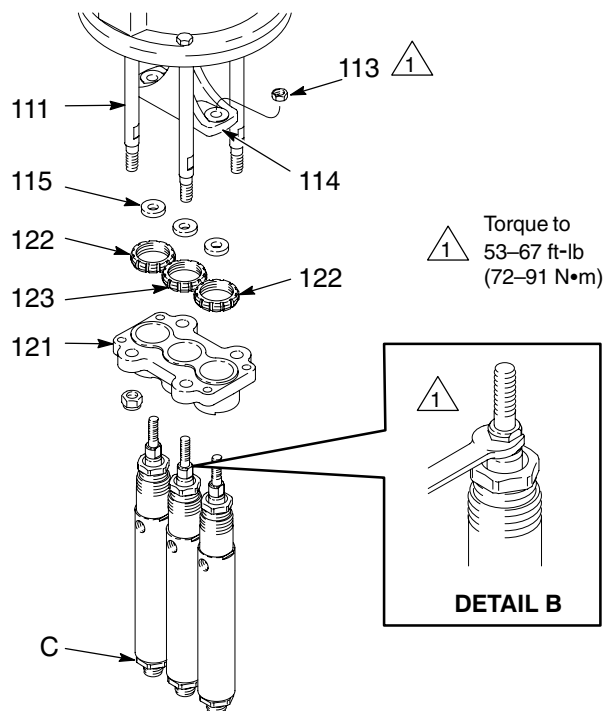

Fig. 19

## Reassembly

1. Slide the center displacement pump rod through the tie plate (121), center locknut (123), and washer (115). Thread the displacement rod into the yoke (114) by turning the complete cylinder. Use a wrench on the flats of the displacement rod for final tightening. Torque to 53–67 ft-lb (72–91 N•m). Push the cylinder up into place in the tie plate and install the center locknut (123).
2. *All pumps*  
Slide the outer two displacement pump rods through the tie plate (121), outer locknuts (122), and washers (115). Install the locknuts (113) loosely on the displacement rods. Push the cylinders up into place in the tie plate and install the outer locknuts (122).

3. Move the air motor to the bottom of its stroke. Check for movement of the air motor yoke at each displacement rod. With the rods centered, tighten the locknuts (113) securely and torque to 53–67 ft-lb (72–91 N•m).
4. Tighten the throat packing nut just enough to prevent leakage, no tighter.
5. Reconnect the swivel unions to the pumps. Hold the intake valve (C) steady with a wrench to prevent it from turning.

# Parts – Bare, Three Pumps

Models 231666 through 231668

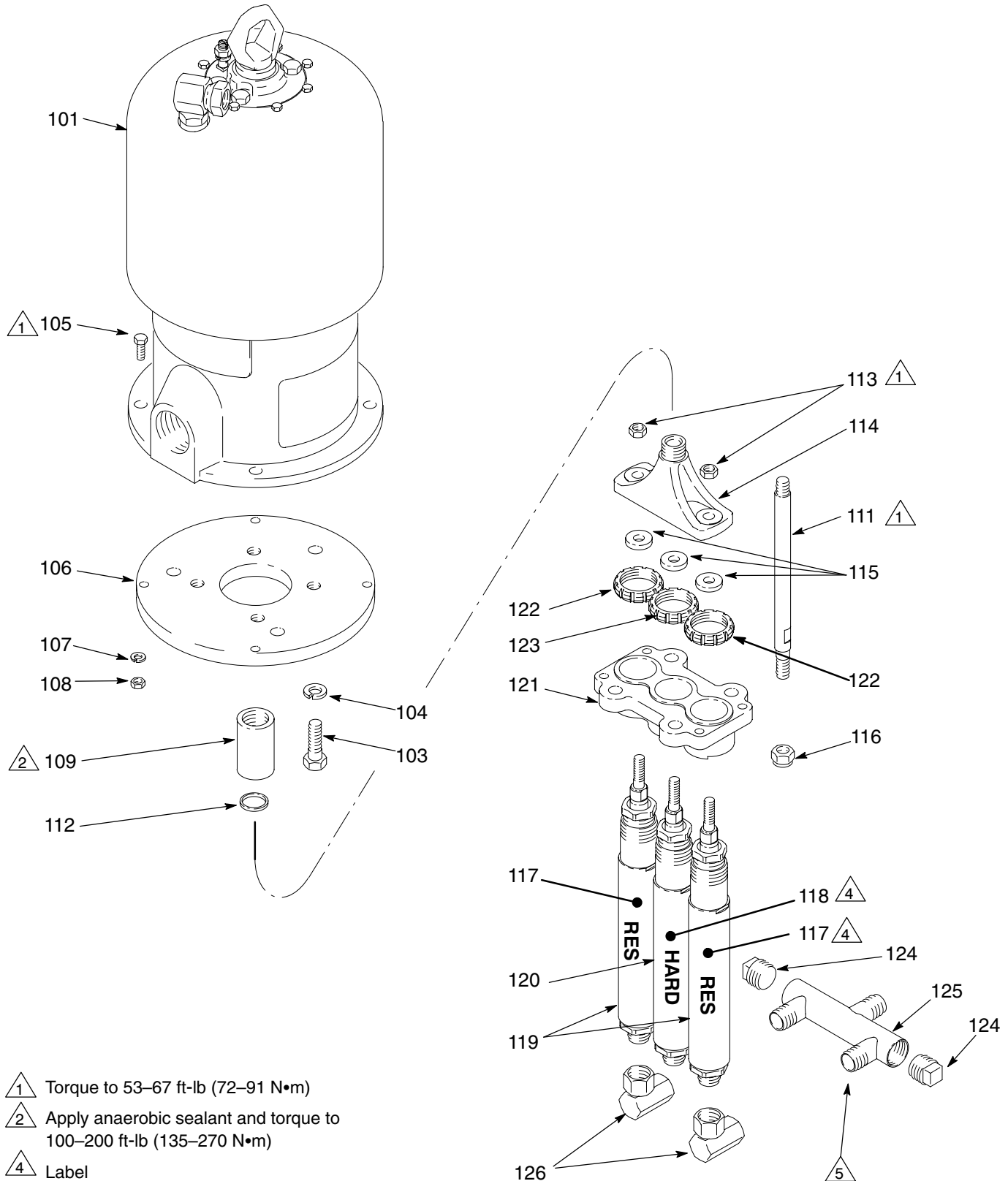

- 1 Torque to 53–67 ft-lb (72–91 N•m)
- 2 Apply anaerobic sealant and torque to 100–200 ft-lb (135–270 N•m)
- 4 Label
- 5 Apply stainless steel pipe sealant to all threaded connections.

02925



# Parts – Bare, Three Pumps

Models 231666 through 231668

Ref. No.	Part No.	Description	Qty.	Ref. No.	Part No.	Description	Qty.
101	245111	KING AIR MOTOR <i>see parts in manual 309347</i>	1	114	164414	YOKE, connector tube	1
103	100128	SCREW, hex cap head, 5/8–11 unc (2a) x 2 in.	3	115	164416	WASHER, flat, 1/2 in.	3
104	100428	LOCKWASHER, 5/8 in.	3	116	101712	LOCKNUT, 5/8–11 unc (2b) w/nylon insert	4
105	100468	SCREW, hex cap head, 3/8–16 unc (2a) x 1 in.	4	117	188975	LABEL, resin	1
106	171122	PLATE, mounting	1	118	188974	LABEL, hardener	1
107	100133	LOCKWASHER, 3/8 in.	4	119	<i>see table</i>	RESIN DISPLACEMENT PUMP	2
108	100307	NUT, hex, 3/8–16 unc (2b)	4	120	<i>see table</i>	HARDENER DISPLACEMENT PUMP	1
109	172726	COUPLER	1	121	<i>see table</i>	TIE PLATE	1
111	168455	TIE ROD, 8.937 in. (227 mm) long shoulder to shoulder	4	122	<i>see table</i>	OUTER LOCKNUT	2
112	150429	GASKET	1	123	<i>see table</i>	CENTER LOCKNUT	1
113	101926	LOCKNUT 1/2–20 unf w/nylon insert	2	124	100345	PLUG, pipe, 11–1/2 npt(f)	2
				125	208334	SUPPLY MANIFOLD	1
				126	156589	SWIVEL UNION, 90°, 3/4 npt (m x f)	2

MODEL	Ref. No. 119		Ref. No. 120		Ref. No. 121	Ref. No. 122	Ref. No. 123
	RESIN PUMP Qty 2	<i>See this manual for parts</i>	HARDENER PUMP	<i>See this manual for parts</i>	TIE PLATE	OUTER LOCKNUT	CENTER LOCKNUT
231666	948641	307944	948640	307944	624912	624887	624887
231667	948640	307944	948640	307944	624912	624887	624887
231668	948640	307944	222015	307944	625218	624887	164417

# Parts – Wall Mount, Three Pumps

Models 231284 through 231286

1 Apply stainless steel pipe sealant to all threaded connections except at swivels

2 Included with bare pump

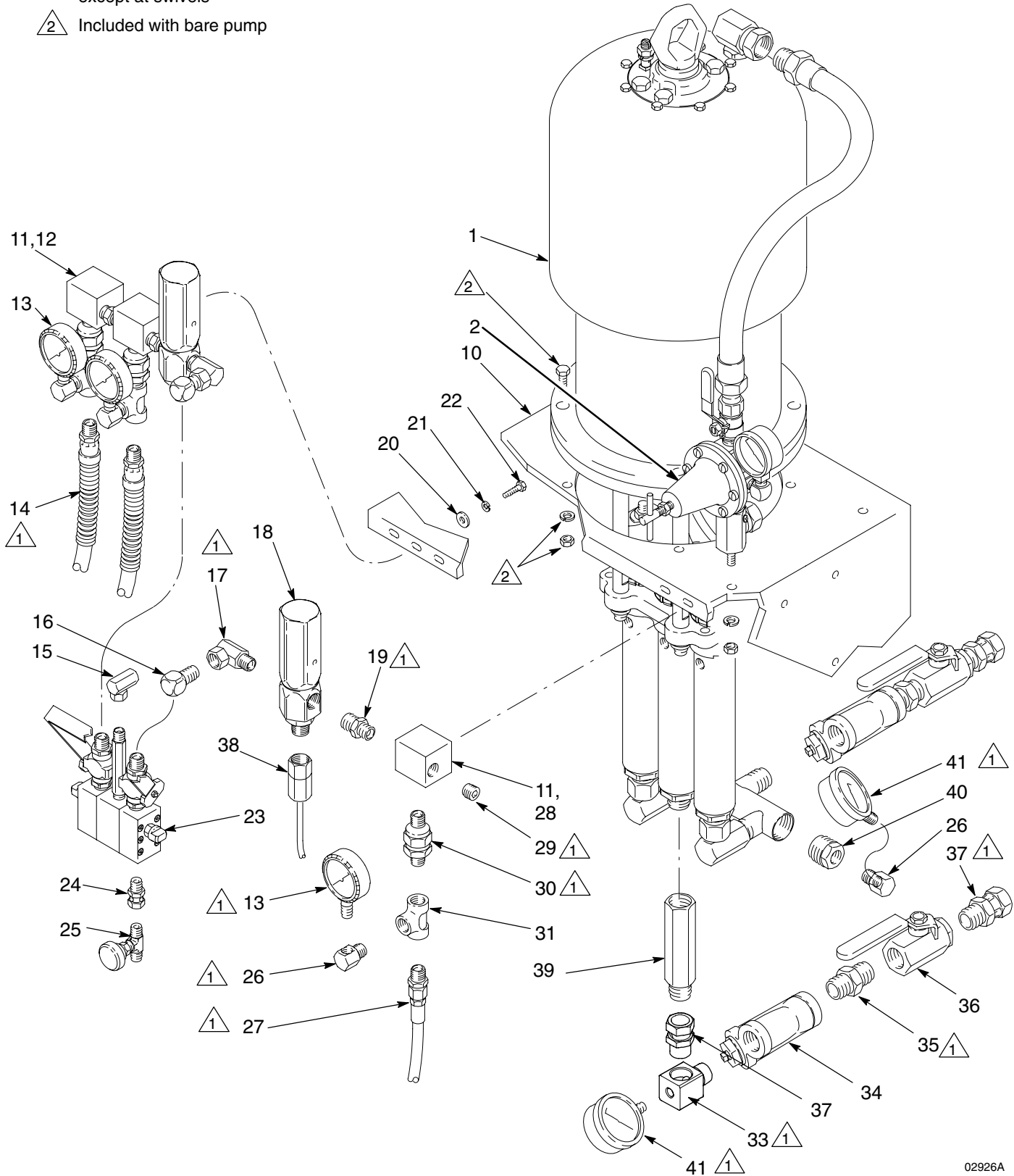

02926A

# Parts – Wall Mount, Three Pumps

## Models 231284 through 231286

Ref. No.	Part No.	Description	Qty.	Ref. No.	Part No.	Description	Qty.
1	<i>see table</i>	BARE PROPORTIONAL PUMP <i>see parts on page 25</i>	1	30	206962	CHECK VALVE, 3/8 npt (mbe)	3
2	207651	AIR REGULATOR KIT <i>see parts in manual 308168</i>	1	31	100483	TEE, pipe, 3/8–18 npt(f)	3
10	236061	BRACKET, mounting	1	33	16X233	ELBOW, street, 90°, 1/4–18 npt(f) x 3/4–14 npt (m x f)	1
11	188596	MANIFOLD BLOCK	3	34	101078	FLUID STRAINER, 3/4 npt <i>Includes item 34a</i>	2
12	188975	LABEL, resin	1	34a	187758	GASKET, PTFE	2
13	<i>see table</i>	PRESSURE GAUGE; used for hardener and resin	1	35	160032	NIPPLE, 3/4 npt	2
14	217378	HOSE, nylon, w/spring guards, cpld 3/8–18 npt (mbe) x 30 in., 3/8 in. ID	2	36	102735	BALL VALVE, 3/4–14 npt(f)	2
15	157676	SWIVEL UNION, 90°, 1/4–18 npt (m x f)	1	37	157785	SWIVEL UNION, 3/4 nps(f) x 3/4 npt (m)	3
16	155699	ELBOW, street, 3/8–18 npt (m x f), carbon steel	2	38	236249	DRAIN KIT ASSEMBLY <i>see parts on page 29</i>	2
17	161037	SWIVEL, 90° 1/2 npte x 3/8 npsmi	2	39	188597	ADAPTER, 3/4–14 npt(f) x 3/4–14 npsm	1
18	<i>see table</i>	PRESSURE RELIEF VALVE	2	40	101742	BUSHING, 3/8 npt x 1 in.	1
19	166469	NIPPLE, 3/4 hex, 3/8–18 npt mbe, sst	1	41	105770	PRESSURE GAUGE, 0–1000 psi (0–0.7 MPa, 0–69 bar), 1/4–18 npt	2
20	111591	WASHER, flat, 1/4 in.	6	42	159239	NIPPLE, 1/2 x 3/8 npte	2
21	100016	LOCKWASHER, 1/4 in.	6				
23	215626	MIXER MANIFOLD <i>See manual 307400</i>	1				
24	156823	NIPPLE	2				
25	108233	NEEDLE (DRAIN) VALVE	2				
26	164259	ELBOW, street, 3/8–18 npt(m) 1/4–18 npt(f)	4				
27	235905	HOSE, cpld, 3/8–18 npt x 30 in. mbe, 0.318 ID, PTFE	1				
28	188974	LABEL, hardener	1				
29	101748	PLUG, pipe, 3/8–18 npt(f), sst	2				

Model	Ref. No. 1	Ref. No. 13	Ref. No. 18
	Bare Pump	Pressure Gauge*	Pressure Relief Valve
231284	231666	102814	237063
231285	231667	102814	237073
231286	231668	102814	237063

\*Pressure Gauge Description:  
102814 0–5000 psi (0–35 MPa, 0–350 bar)  
1/4–18 npt

# Parts— Stand Mount, Three Pumps

Models 231289 through 231291

⚠ Apply anaerobic sealant and torque to 10–15 ft-lb (14–20 N•m)

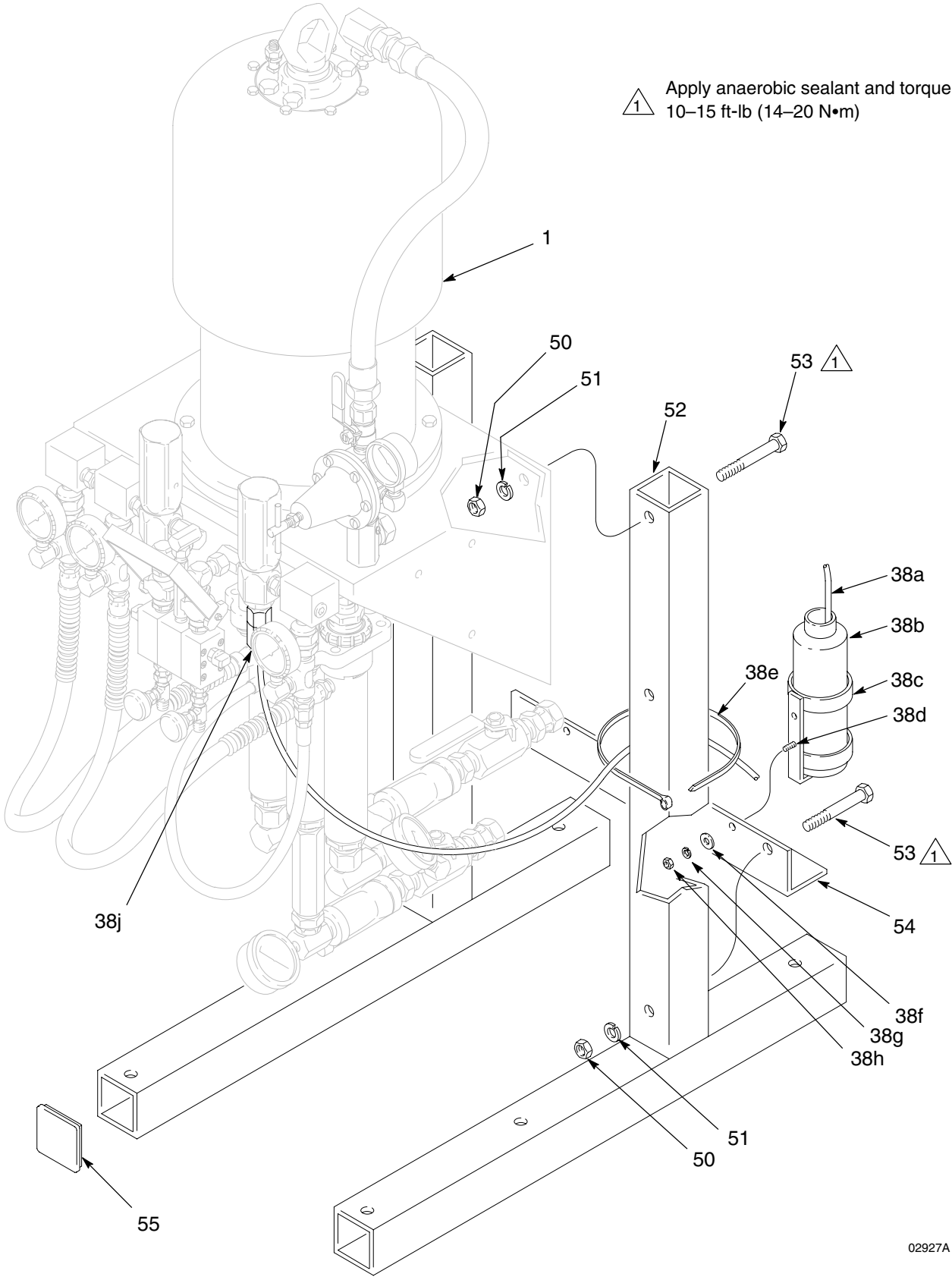

02927A

# Parts – Stand Mount, Three Pumps

Ref. No.	Part No.	Description	Qty.
1	<i>see table</i>	WALL MOUNT PUMP <i>see parts on page 27</i>	1
50	100321	NUT, hex, 1/2–13 unc	6
51	100018	LOCKWASHER, 1/2 in.	6
52	217297	LEG, frame	2
53	100679	SCREW, hex cap head, 1/2–13 unc (2a) x 3-1/2 in.	6
54	178473	BRACE, frame	1
55	168422	CAP, square tube	6

Model	Ref. No. 1
	Wall Pump
231289	231284
231290	231285
231291	231286

## Ref No. 38 Drain Valve Kit

Supplied with the Wall Mount units and Stand Mount units

Ref. No.	Part No.	Description	Qty.
38a	190738	. TUBE, nylon, 36 in. x 1/2 in. OD	1
38b	112279	. BOTTLE	1
38c	236272	. HOLDER, bottle	1
38d	100022	. SCREW, hex cap head, 1/4–20 unc (2a)	1
38e	112278	. TIE WRAP	1
38f	100016	. LOCKWASHER, 1/4 in.	1
38g	111591	. WASHER, flat, 1/4 in.	1
38h	100015	. NUT HEX, 1/4–20 unc (2b)	1
38j	113187	. CONNECTOR, female, tube	1

# Accessories

## Parts for Installing Optional Heaters

The following components are recommended to install the heaters as instructed on page 10. Two displacement pump models need Items 201 to 204. Three displacement pump models need Items 201 to 205 and an additional resin and hardener hose of an appropriate length.

Ref. No.	Part No.	Description	Qty.
201	—	FLUID HEATER; <i>select from list to the right</i>	2
202	155494	SWIVEL UNION, 90°, 3/8–18 npt (m x f)	2
203	161037	SWIVEL UNION, 90°, 1/2 npt(f) x 3/8–18 nps(m)	2
204	235905	HOSE, cpld; hardener, 3/8–18 npt x 30 in. mbe 0.318 ID PTFE	1
205	217378	HOSE, nylon, w/spring guards; resin, cpld 3/8–18 npt x 30 in. (mbe) 3/8 in. ID	1

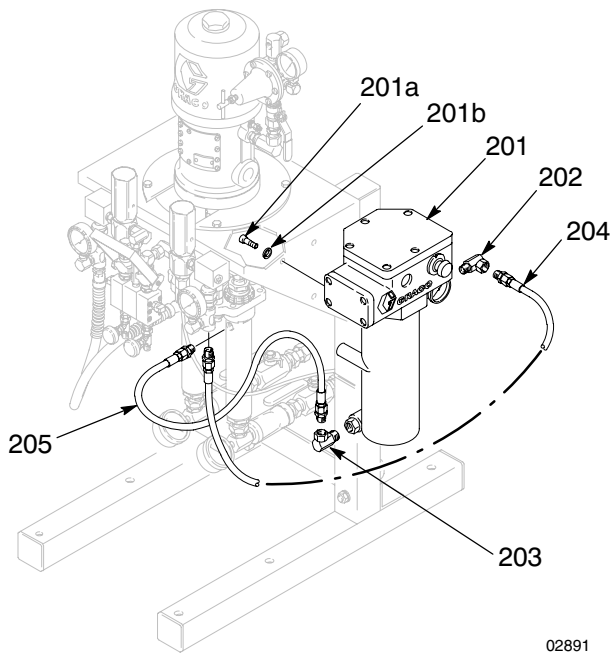

## Viscon HP Fluid Heaters

### Style A

**Model 245848**, 120 Volt, Stainless Steel

4000 psi (28 MPa, 276 bar) Maximum Working Pressure  
85° – 220° F (29° – 104° C) Temperature Range

**Model 245863**, 240 Volt, Stainless Steel

4000 psi (28 MPa, 276 bar) Maximum Working Pressure  
85° – 220° F (29° – 104° C) Temperature Range

**Model 245864**, 480 Volt, Stainless Steel

4000 psi (28 MPa, 276 bar) Maximum Working Pressure  
85° – 220° F (29° – 104° C) Temperature Range

### Style B

**Model 226819**, 240 Volt Aluminum and Zinc

3000 psi (21 MPa, 210 bar) Maximum Working Pressure  
80° – 190° F (26° – 88° C) Temperature Range

Style A  
Model 245848 shown

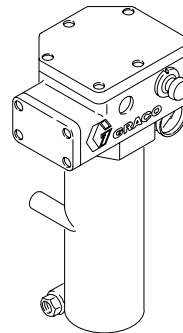

Style B  
Model 226819 shown

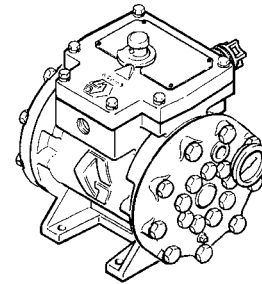

# Accessories

## Parts for Installing Optional Solvent Pump

Ref. No.	Part No.	Description	Qty.
301	151519	NIPPLE, reducing, 1/4-19 nptm x 1/8-27 nptm	2
302	111913	COUPLING, hose, 1/4-18 npsm, w/spring guard, stainless steel	2
303	061132	HOSE, nylon 1/4 in. ID x 36 in. long	1
304	206264	VALVE, needle, 1/4-18 npt (m)	1
305	158841	ADAPTER, 1/4-18 unc (f) x 3/8-18 npt (m), carbon steel	1
306	217523	10:1 RATIO MONARK PUMP for heavy viscosity system	1
<b>OR</b>	208470	5:1 RATIO MONARK PUMP for light viscosity system	1
307	157350	ADAPTER, 3/8-18 npt x 1/4-18 npt (mbe)	1
308	155541	SWIVEL UNION, 90°, 1/4 npt (f x m)	1
309	<i>as needed</i>	FLUID HOSE	
310	207365	BRACKET, mounting	1
311	241037	BALL VALVE	1
312	207484	SUCTION TUBE ASSEMBLY, 3/4 npt	1
313	100101	SCREW, hex cap head, 3/8-16 unc (2a) x 1 in.	4
314	100133	LOCK WASHER, 3/8 in.	4
315	100307	NUT, hex, 3/8-16 unc (2b)	4
316	100132	WASHER, flat, 7/16 in.	4

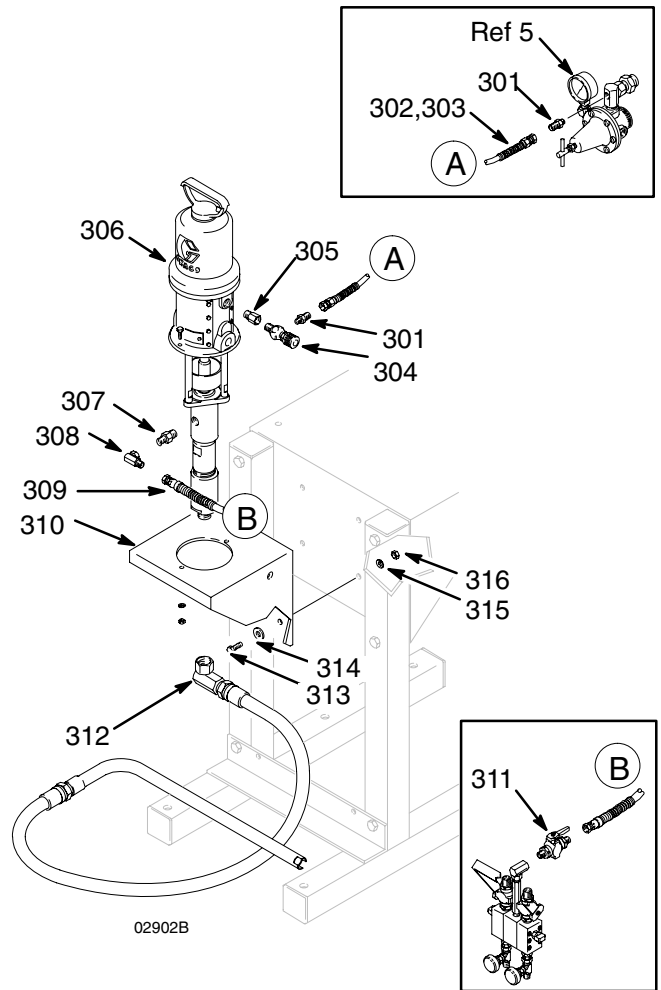

## Miscellaneous Accessories

### Nitrogen Regulator Kit, 207638

Maintains a nitrogen head on the supply drum to protect materials from moisture. Kit includes two 6 ft x 1/4 in. (1.8 m x 6 mm) hoses, control box with gauge, regulator, and relief valve.

Inlet: 1/4 in. npt(m). Outlet: 3/4: npt (m).

### Graco Throat Seal Liquid

Non-evaporating liquid for wet-cup

**206995** 0.95 liter (1 quart)

**206996** 3.8 liter (1 gallon)

### ISO Pump Oil

A highly refined, special purpose throat seal lubricant the minimal reaction with Isocyanates.

**217374** 16 oz (0.13 liter) container

**218656** 4 gallon (18.14 liter) container

### Grounding Wire and Clamp, 222011

7.6 m (25 ft) long,  
1.5 mm<sup>2</sup> (12 gauge)

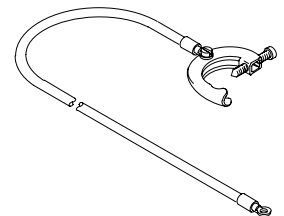

# Accessories

## Air Control Accessories

### Bleed-Type Master Air Valve

300 psi (2.1 MPa, 21 bar) Maximum Working Pressure  
Relieves air trapped in the air line between the pump air inlet and this valve when closed.

**107141**

3/4 npt(m) inlet x 3/4 npt(f) outlet

**107142**

1/2 npt(m) inlet x 1/2 npt(f) outlet

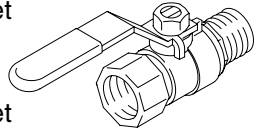

### Air Line Filter 106149

250 psi (1.8 MPa, 17.5 bar) Maximum Working Pressure  
Filters harmful dirt and moisture from the compressed air supply. 1/2 npt(f) inlet and outlet.  
See instruction manual 308169.

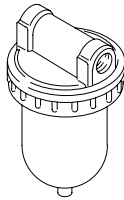

### Air Line Lubricator 214848

250 psi (1.8 MPa, 17.5 bar) Maximum Working Pressure  
Provides automatic lubrication for the air motor.  
0.48 liter (16 oz) bowl capacity.  
1/2 npt(f) inlet and outlet.  
See instruction manual 308169.

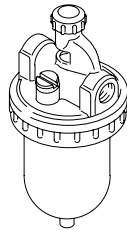

### Pump Runaway Valve 224040

120 psi (0.8 MPa, 8.4 bar) Maximum Working Pressure  
Shuts off air supply to the pump if the pump accelerates beyond the pre-adjusted setting due to an empty supply container, interrupted fluid supply to the pump, or excessive cavitation.  
3/4 npt(f) inlet and outlet.  
Includes optional 90°, 3/4 npsm swivel outlet fitting.  
See instruction manual 308201.

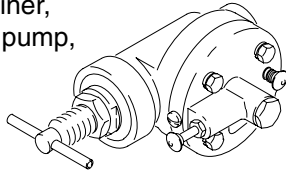

### Air Regulator 206197

300 psi (2.1 MPa, 21 bar) Maximum Working Pressure  
Controls air pressure to feed, solvent, or proportioning pumps. 1/2 npt inlets and outlets, with (2) 1/4 npt pressure gauge outlets.

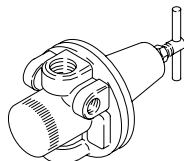

## Fluid Control Accessories

### Fluid Filter

5000 psi (35 MPa, 350 bar) Maximum Working Pressure  
60 mesh (250 micron) screen.

**Model 218029**

Carbon steel bowl and support

**Model 223160**

Stainless steel bowl and polyethylene support

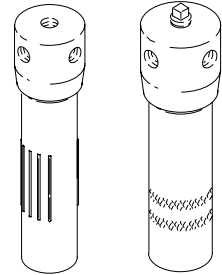

### Fluid Shutoff Valve

5000 psi (35 MPa, 350 bar) Maximum Working Pressure

**Model 235992**

stainless steel with PTFE seals  
1/4 x 3/8 nps (mbe)

**Model 223960**

carbon steel with PTFE seals  
3/8 npt (mbe)

**Model 214037**

carbon steel with PTFE seals  
1/4 npt (mbe)

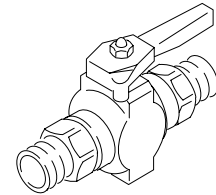

### Static Mixing Units

3000 psi (21 MPa, 210 bar) Maximum Working Pressure  
These units consist of a tube with helical interior elements which thoroughly blend base and catalyst materials into the proper mix.

**Model 208056**

7 in. (178 mm) long, 1/4 in. (6 mm) ID, 21 Elements  
fittings included

**Model 500639**

14 in. (356 mm) long, 5/16 in. (8 mm) ID, 27 Elements  
3/8 npt order fittings separately

**Model 500586**

25 in. (635 mm) long, 0.44 in. (11 mm) ID, 32 Elements  
1/2 npt order fittings separately

**Model 502028**

29 in. (736 mm) long, 0.8 in. (20 mm) ID, 24 Elements  
3/4 npt

**Model 945917**

25 in. (635 mm) long, 2-1/2 in. (64 mm) OD, 10 Elements  
1 in. npt (m x f)



# Dimensions

# Mounting Hole Layout for Air Motor

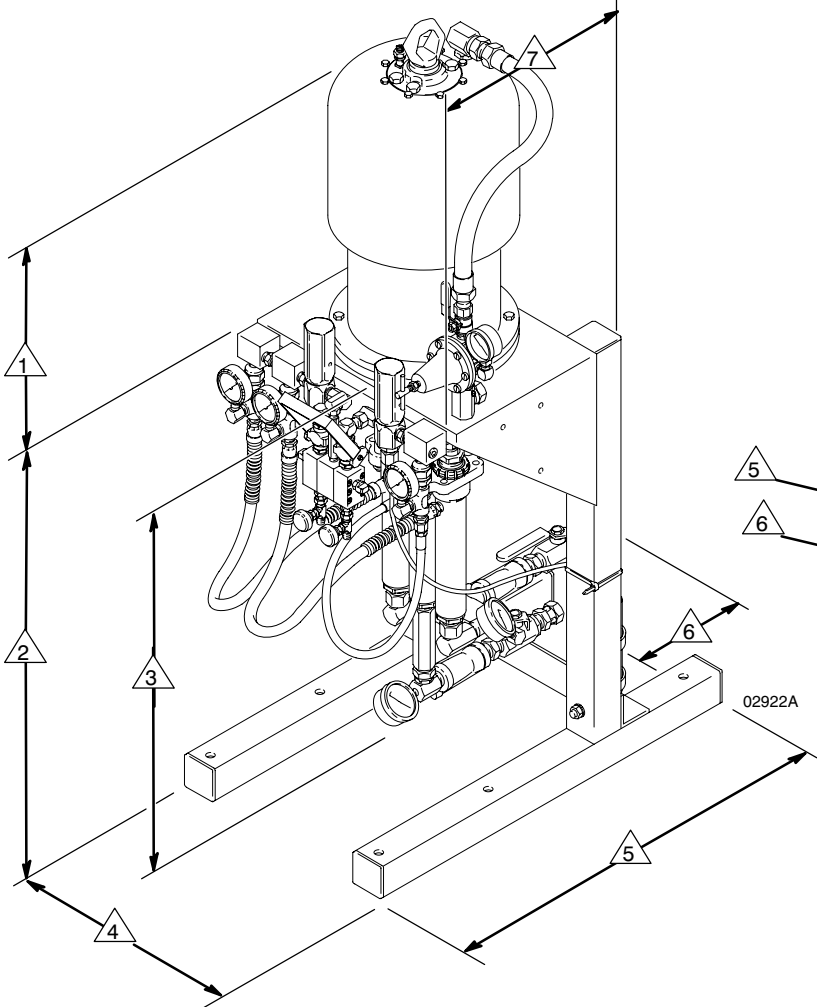

- △1 21.5 in. (534 mm)
- △2 32.75 in. (832 mm)
- △3 28.25 in. (718 mm)
- △4 17.75 in. (451 mm)
- △5 30.25 in. (768 mm)
- △6 11 in. (279 mm)
- △7 12.5 in. (318 mm)

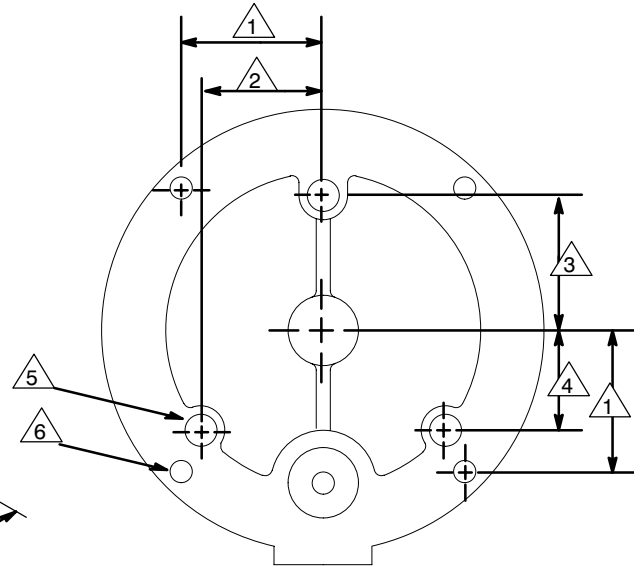

02922A

01838

- △1 3.712 in. (94 mm)
- △2 3.46 in. (88 mm)
- △3 4 in. (102 mm)
- △4 2 in. (51 mm)
- △5 5/8–11 UNC (3) for pump mounting
- △6 0.44 in. (11.1 mm) diameter (4)

# Technical Data

## Pumps

Category	Data
Air operating range	40–100 psi (0.3–0.7 MPa, 3–7 bar)
Air consumption	See example below
Fluid inlet size	3/4 npt
Fluid outlet size	3/8 npt
Air inlet size	3/4 npt
Maximum fluid outlet pressure	250 psi (1.7 MPa, 17 bar)
Maximum fluid inlet pressure	250 psi (1.7 MPa, 17 bar)
Wetted parts	Stainless steel, Tungsten Carbide, Chrome plating, Carbon steel, PTFE Ultra-high molecular weight polyethylene

## Manifold Assemblies

Category	Data
Manifold outlets	3/8 npt
Hoses	3/8 in. ID, PTFE, cpld 3/8 npt(m) 4000 psi (28 MPa, 276 bar) maximum working pressure
	3/8 in. ID, Nylon, cpld 3/8 npt(m) 3000 psi (21 MPa, 210 bar) maximum working pressure
Automatic pressure relief valves wetted parts	303 stainless steel, Tungsten carbide, fluoroelastomer

### Air consumption example:

When the air pressure to the pump is 60 psi (0.4 MPa, 4 bar) and you are dispensing 1 gal. (3.8 liter) of mixed fluid per minute, air volume used, in cfm, will be about the same as the larger pressure ratio figure of your pump. See page 4 for pressure ratios of pumps.



# Graco Standard Warranty

Graco warrants all equipment manufactured by Graco and bearing its name to be free from defects in material and workmanship on the date of sale to the original purchaser for use. With the exception of any special, extended, or limited warranty published by Graco, Graco will, for a period of twelve months from the date of sale, repair or replace any part of the equipment determined by Graco to be defective. This warranty applies only when the equipment is installed, operated and maintained in accordance with Graco's written recommendations.

This warranty does not cover, and Graco shall not be liable for general wear and tear, or any malfunction, damage or wear caused by faulty installation, misapplication, abrasion, corrosion, inadequate or improper maintenance, negligence, accident, tampering, or substitution of non-Graco component parts. Nor shall Graco be liable for malfunction, damage or wear caused by the incompatibility of Graco equipment with structures, accessories, equipment or materials not supplied by Graco, or the improper design, manufacture, installation, operation or maintenance of structures, accessories, equipment or materials not supplied by Graco.

This warranty is conditioned upon the prepaid return of the equipment claimed to be defective to an authorized Graco distributor for verification of the claimed defect. If the claimed defect is verified, Graco will repair or replace free of charge any defective parts. The equipment will be returned to the original purchaser transportation prepaid. If inspection of the equipment does not disclose any defect in material or workmanship, repairs will be made at a reasonable charge, which charges may include the costs of parts, labor, and transportation.

**THIS WARRANTY IS EXCLUSIVE, AND IS IN LIEU OF ANY OTHER WARRANTIES, EXPRESS OR IMPLIED, INCLUDING BUT NOT LIMITED TO WARRANTY OF MERCHANTABILITY OR WARRANTY OF FITNESS FOR A PARTICULAR PURPOSE.**

Graco's sole obligation and buyer's sole remedy for any breach of warranty shall be as set forth above. The buyer agrees that no other remedy (including, but not limited to, incidental or consequential damages for lost profits, lost sales, injury to person or property, or any other incidental or consequential loss) shall be available. Any action for breach of warranty must be brought within two (2) years of the date of sale.

Graco makes no warranty, and disclaims all implied warranties of merchantability and fitness for a particular purpose in connection with accessories, equipment, materials or components sold but not manufactured by Graco. These items sold, but not manufactured by Graco (such as electric motors, switches, hose, etc.), are subject to the warranty, if any, of their manufacturer. Graco will provide purchaser with reasonable assistance in making any claim for breach of these warranties.

In no event will Graco be liable for indirect, incidental, special or consequential damages resulting from Graco supplying equipment hereunder, or the furnishing, performance, or use of any products or other goods sold hereto, whether due to a breach of contract, breach of warranty, the negligence of Graco, or otherwise.

## **FOR GRACO CANADA CUSTOMERS**

The parties acknowledge that they have required that the present document, as well as all documents, notices and legal proceedings entered into, given or instituted pursuant hereto or relating directly or indirectly hereto, be drawn up in English. Les parties reconnaissent avoir convenu que la rédaction du présente document sera en Anglais, ainsi que tous documents, avis et procédures judiciaires exécutés, donnés ou intentés à la suite de ou en rapport, directement ou indirectement, avec les procédures concernées.

# Graco Information

For the latest information about Graco products, visit [www.graco.com](http://www.graco.com).

**TO PLACE AN ORDER**, contact your Graco distributor, or call one of the following numbers to identify the distributor closest to you:

**1-800-328-0211 Toll Free**

**612-623-6921**

**612-378-3505 Fax**

*All written and visual data contained in this document reflects the latest product information available at the time of publication. Graco reserves the right to make changes at any time without notice.*

*For patent information, see [www.graco.com/patents](http://www.graco.com/patents).*

Original instructions. This manual contains English. MM 308226

**Graco Headquarters:** Minneapolis

**International Offices:** Belgium, China, Japan, Korea

**GRACO INC. AND SUBSIDIARIES • P.O. BOX 1441 • MINNEAPOLIS MN 55440-1441 • USA**

**Copyright 1994, Graco Inc. All Graco manufacturing locations are registered to ISO 9001.**

[www.graco.com](http://www.graco.com)

Revised December 2013