



This manual contains important warnings and information.
READ AND KEEP FOR REFERENCE.

INSTRUCTIONS

First choice when quality counts.™

CARBON STEEL **Dura-Flo™ 600 Pumps**

With Severe-Duty Rod and Cylinder

Refer to page 2 for a List of Models and the Table of Contents.

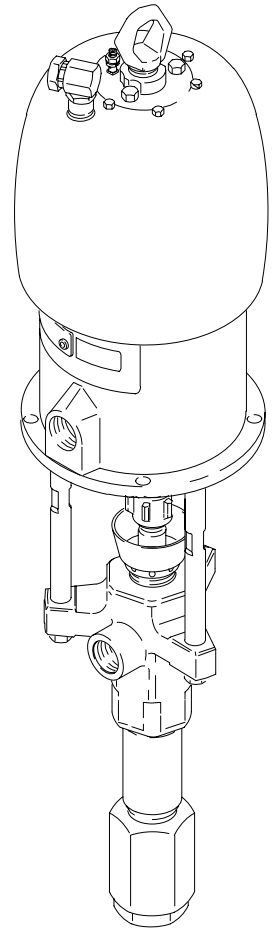

Model 236463

05242

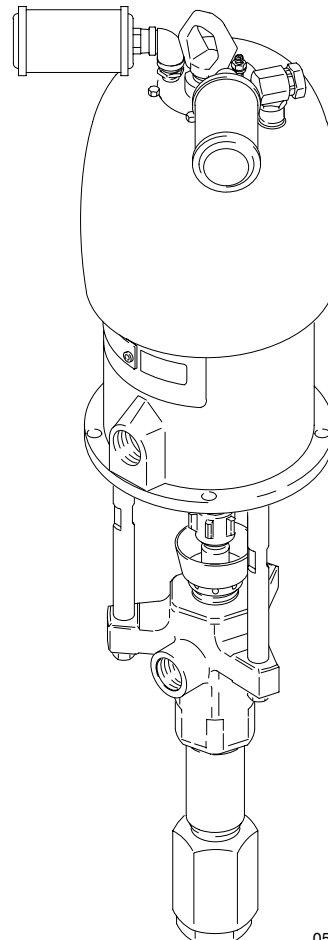

Model 237369

05250



List of Models

Pump Part No. and Series	Pump Model	Displacement Pump Part No. and Series★	Ratio	Maximum Fluid Working Pressure	Maximum Air Input Pressure
236463, Series A	Bulldog®	236457, Series A	41:1	28.3 MPa, 283 bar (4100 psi)	0.7 MPa, 7 bar (100 psi)
237369, Series A	Reduced Icing Quiet Bulldog®	236457, Series A	41:1	28.3 MPa, 283 bar (4100 psi)	0.7 MPa, 7 bar (100 psi)
237371, Series A	Bulldog®, with riser tube	236457, Series A	41:1	28.3 MPa, 283 bar (4100 psi)	0.7 MPa, 7 bar (100 psi)

★ This manual also covers Part No. 238036 Displacement Pump, which is available as an option. See page 24.

Table of Contents

Warnings	3	Parts Drawings and Parts Lists	21
Installation	7	Pump Assemblies	21
Operation/Maintenance	10	Displacement Pump	23
Troubleshooting Chart	13	Technical Data	25
Service	14	Dimensions	27
Required Tools	14	Mounting Hole Layout	27
Disconnecting the Displacement Pump	14	Warranty	28
Reconnecting the Displacement Pump	14	Graco Phone Number	28
Displacement Pump Service	16		

Symbols

Warning Symbol



This symbol alerts you to the possibility of serious injury or death if you do not follow the instructions.

Caution Symbol



This symbol alerts you to the possibility of damage to or destruction of equipment if you do not follow the instructions.

WARNING



INSTRUCTIONS

EQUIPMENT MISUSE HAZARD

Equipment misuse can cause the equipment to rupture or malfunction and result in serious injury.

- This equipment is for professional use only.
- Read all instruction manuals, tags, and labels before operating the equipment.
- Use the equipment only for its intended purpose. If you are uncertain about usage, call your Graco distributor.
- Do not alter or modify this equipment. Use only genuine Graco parts and accessories.
- Check equipment daily. Repair or replace worn or damaged parts immediately.
- Do not exceed the maximum working pressure of the lowest rated system component. Refer to the **Technical Data** on page 25 for the maximum working pressure of this equipment.
- Use fluids and solvents which are compatible with the equipment wetted parts. Refer to the **Technical Data** section of all equipment manuals. Read the fluid and solvent manufacturer's warnings.
- Do not use hoses to pull equipment.
- Route hoses away from traffic areas, sharp edges, moving parts, and hot surfaces. Do not expose Graco hoses to temperatures above 82°C (180°F) or below -40°C (-40°F).
- Wear hearing protection when operating this equipment.
- Do not lift pressurized equipment.
- Comply with all applicable local, state, and national fire, electrical, and safety regulations.

WARNING

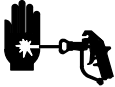

INJECTION HAZARD

Spray from the gun, hose leaks, or ruptured components can inject fluid into your body and cause extremely serious injury, including the need for amputation. Fluid splashed in the eyes or on the skin can also cause serious injury.



- Fluid injected into the skin might look like just a cut, but it is a serious injury. **Get immediate medical attention.**
- Do not point the gun at anyone or at any part of the body.
- Do not put your hand or fingers over the spray tip.
- Do not stop or deflect leaks with your hand, body, glove or rag.
- Do not “blow back” fluid; this is not an air spray system.
- Always have the tip guard and the trigger guard on the gun when spraying.
- Check the gun diffuser operation weekly. Refer to the gun manual.
- Be sure the gun trigger safety operates before spraying.
- Lock the gun trigger safety when you stop spraying.
- Follow the **Pressure Relief Procedure** on page 10 whenever you: are instructed to relieve pressure; stop spraying; clean, check, or service the equipment; and install or clean the spray tip.
- Tighten all fluid connections before operating the equipment.
- Check the hoses, tubes, and couplings daily. Replace worn, damaged, or loose parts immediately. Permanently coupled hoses cannot be repaired; replace the entire hose.
- Use only Graco approved hoses. Do not remove any spring guard that is used to help protect the hose from rupture caused by kinks or bends near the couplings.



MOVING PARTS HAZARD

Moving parts, such as the air motor piston, can pinch or amputate your fingers.

- Keep clear of all moving parts when starting or operating the pump.
- Before servicing the equipment, follow the **Pressure Relief Procedure** on page 10 to prevent the equipment from starting unexpectedly.

WARNING



FIRE AND EXPLOSION HAZARD

Improper grounding, poor ventilation, open flames or sparks can cause a hazardous condition and result in a fire or explosion and serious injury.

- Ground the equipment and the object being sprayed. Refer to **Grounding** on page 7.
- If there is any static sparking or you feel an electric shock while using this equipment, **stop spraying immediately**. Do not use the equipment until you identify and correct the problem.
- Provide fresh air ventilation to avoid the buildup of flammable fumes from solvents or the fluid being sprayed.
- Keep the spray area free of debris, including solvent, rags, and gasoline.
- Electrically disconnect all equipment in the spray area.
- Extinguish all open flames or pilot lights in the spray area.
- Do not smoke in the spray area.
- Do not turn on or off any light switch in the spray area while operating or if fumes are present.
- Do not operate a gasoline engine in the spray area.



TOXIC FLUID HAZARD

Hazardous fluid or toxic fumes can cause serious injury or death if splashed in the eyes or on the skin, inhaled, or swallowed.

- Know the specific hazards of the fluid you are using.
- Store hazardous fluid in an approved container. Dispose of hazardous fluid according to all local, state and national guidelines.
- Always wear protective eyewear, gloves, clothing and respirator as recommended by the fluid and solvent manufacturer.

Notes

Installation

General Information

NOTE: Reference numbers and letters in parentheses in the text refer to the callouts in the figures and the parts drawing.

NOTE: Always use Genuine Graco Parts and Accessories, available from your Graco distributor. Refer to the Product Data Sheet, Form No. 305724. If you supply your own accessories, be sure they are adequately sized and pressure rated for your system.

Grounding

⚠ WARNING

FIRE AND EXPLOSION HAZARD
Before operating the pump, ground the system as explained below. Also read the section **FIRE AND EXPLOSION HAZARD** on page 5.



1. *Pump:* use a ground wire and clamp. See Fig. 1. Loosen the grounding lug locknut (W) and washer (X). Insert one end of a 1.5 mm² (12 ga) minimum ground wire (Y) into the slot in lug (Z) and tighten the locknut securely. Connect the other end of the wire to a true earth ground. Order Part No. 237569 Ground Wire and Clamp.

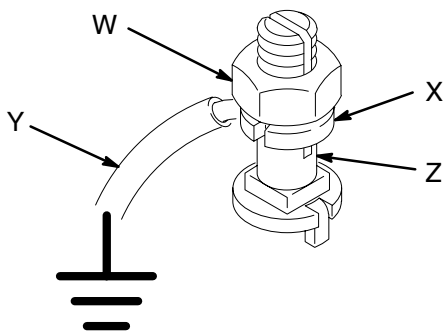

Fig. 1

0864

2. *Air and fluid hoses:* use only electrically conductive hoses.

3. *Air compressor:* follow manufacturer's recommendations.
4. *Spray gun:* ground through connection to a properly grounded fluid hose and pump.
5. *Fluid supply container:* follow your local code.
6. *Object being sprayed:* follow your local code.
7. *Solvent pails used when flushing:* follow your local code. Use only metal pails, which are conductive, placed on a grounded surface. Do not place the pail on a nonconductive surface, such as paper or cardboard, which interrupts the grounding continuity.
8. *To maintain grounding continuity when flushing or relieving pressure,* hold a metal part of the spray gun firmly to the side of a grounded *metal* pail, then trigger the gun.

System Accessories

Fig. 2 is only a guide for selecting and installing system components and accessories. Contact your Graco distributor for assistance in designing a system to suit your particular needs.

Air and Fluid Hoses

Be sure all air hoses (H) and fluid hoses (N and P) are properly sized and pressure-rated for your system. Use only electrically conductive hoses. Fluid hoses must have spring guards on both ends. Use a whip hose (P) and a swivel (R) between the main fluid hose (N) and the gun (S) to allow freer gun movement.

Mounting Accessories

Mount the pump (A) to suit the type of installation planned. Fig. 2 illustrates a wall mount system. Pump dimensions and the mounting hole layout are shown on page 27.

If you are using a floor stand, refer to its separate manual for installation and operation instructions.

Installation

System Accessories (continued)

WARNING

A bleed-type master air valve (E) and a fluid drain valve (M) are required in your system. These accessories help reduce the risk of serious injury, including fluid injection and splashing of fluid in the eyes or on the skin, and injury from moving parts if you are adjusting or repairing the pump.

The bleed-type master air valve relieves air trapped between this valve and the pump after the air is shut off. Trapped air can cause the pump to cycle unexpectedly. Locate the valve close to the pump. Order Part No. 107141.

The fluid drain valve assists in relieving fluid pressure in the displacement pump, hose, and gun. Triggering the gun to relieve pressure may not be sufficient. Order Part No. 210658.

Air Line Accessories

Install the following accessories in the locations shown in Fig. 2, using adapters as necessary:

- **An air line lubricator (D)** provides automatic air motor lubrication.
- **A bleed-type master air valve (E)** is required in your system to relieve air trapped between it and the air motor when the valve is closed (see the **WARNING** above). Be sure the bleed valve is easily accessible from the pump, and is located **downstream** from the air regulator.
- **An air regulator (F)** controls pump speed and outlet pressure by adjusting the air pressure to the pump. Locate the regulator close to the pump, but **upstream** from the bleed-type master air valve.
- **A pump runaway valve (C)** senses when the pump is running too fast and automatically shuts off the air to the motor. A pump which runs too fast can be seriously damaged.
- **An air manifold (G)** has a 3/4 npsm(f) swivel air inlet. It mounts to the pump support bracket, and provides ports for connecting lines to air-powered accessories.
- **An air line filter (J)** removes harmful dirt and moisture from the compressed air supply. Also, install a **drain valve (W)** at the bottom of each air line drop, to drain off moisture.
- **A second bleed-type air valve (K)** isolates the air line accessories for servicing. Locate upstream from all other air line accessories.

Fluid Line Accessories

Install the following accessories in the locations shown in Fig. 2, using adapters as necessary:

- **A fluid filter (L)** with a 60 mesh (250 micron) stainless steel element, to filter particles from the fluid as it leaves the pump.
- **A fluid drain valve (M)**, which is required in your system, helps relieve fluid pressure in the hose and gun (see the **WARNING** at left).
- **A gun (S)** dispenses the fluid. The gun shown in Fig. 2 is an airless spray gun for light to medium viscosity fluids.
- **A gun swivel (R)** allows freer gun movement.
- **A suction kit (T)** allows the pump to draw fluid from a supply container.

Installation

TYPICAL INSTALLATION

KEY

- | | | |
|---|--|---|
| A Pump | J Air Line Filter | R Gun Swivel |
| B Wall Bracket | K Bleed-Type Master Air Valve (for accessories) | S Airless Spray Gun |
| C Pump Runaway Valve | L Fluid Filter | T Suction Kit |
| D Air Line Lubricator | M Fluid Drain Valve (required) | Y Ground Wire and Clamp (required; see page 7 for installation instructions) |
| E Bleed-Type Master Air Valve (required, for pump) | N Electrically Conductive Fluid Supply Hose | W Air Line Drain Valve |
| F Pump Air Regulator | P Fluid Whip Hose | |
| G Air Manifold | | |
| H Electrically Conductive Air Supply Hose | | |

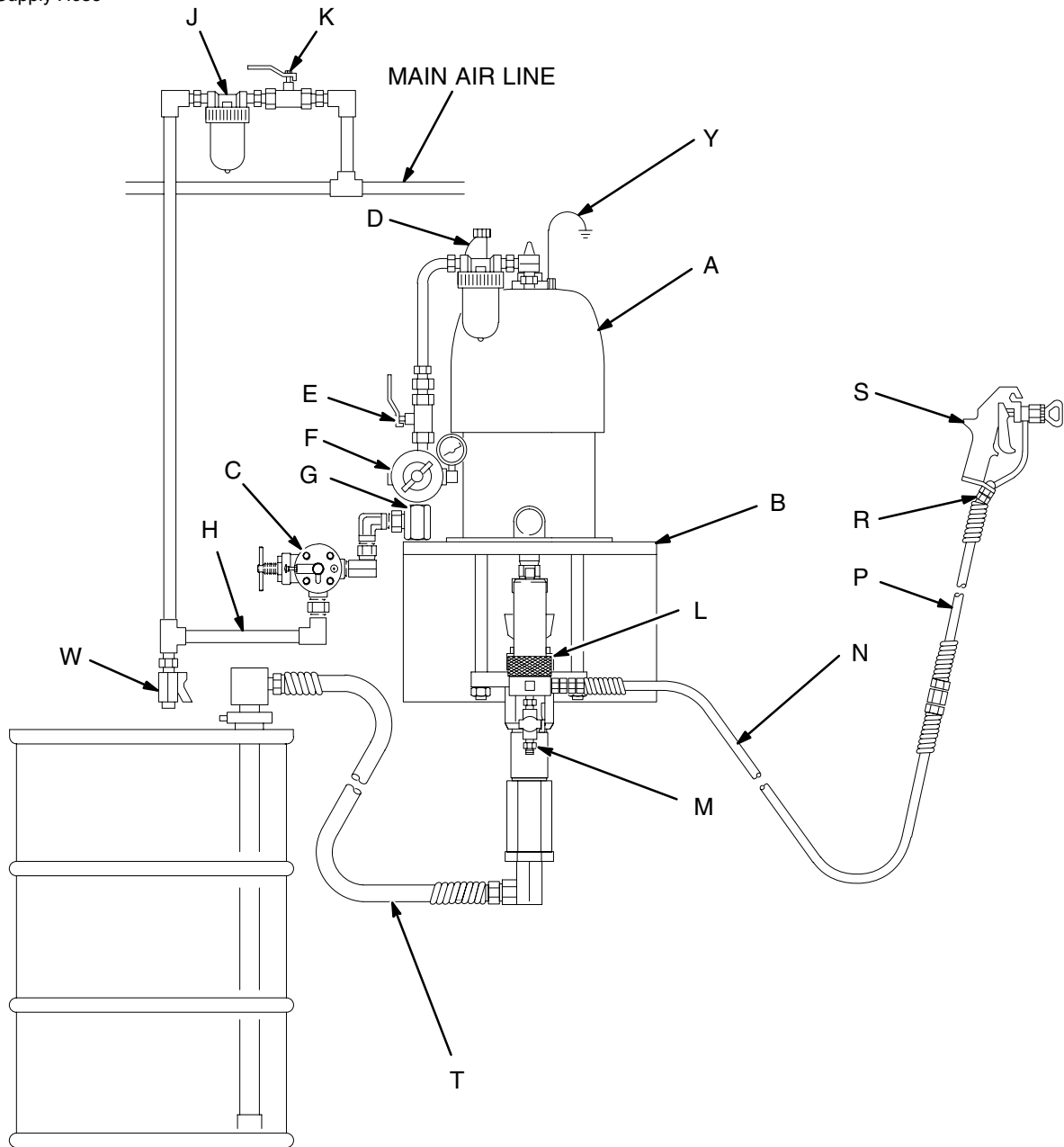

Fig. 2

04496

Operation/Maintenance

Pressure Relief Procedure

WARNING

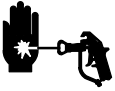

INJECTION HAZARD

The system pressure must be manually relieved to prevent the system from starting or spraying accidentally. Fluid under high pressure can be injected through the skin and cause serious injury. To reduce the risk of an injury from injection, splashing fluid, or moving parts, follow the **Pressure Relief Procedure** whenever you:

- are instructed to relieve the pressure,
- stop spraying,
- check or service any of the system equipment,
- or install or clean the spray tips.

1. Lock the gun trigger safety.
2. Shut off the air supply to the pump.
3. Close the bleed-type master air valve (required in your system).
4. Unlock the gun trigger safety.
5. Hold a metal part of the gun firmly to the side of a grounded metal pail, and trigger the gun to relieve pressure.
6. Lock the gun trigger safety.
7. Open the drain valve (required in your system), having a container ready to catch the drainage.
8. Leave the drain valve open until you are ready to spray again.

If you suspect that the spray tip or hose is completely clogged, or that pressure has not been fully relieved after following the steps above, very slowly loosen the tip guard retaining nut or hose end coupling and relieve pressure gradually, then loosen completely. Now clear the tip or hose.

Packing Nut/Wet-Cup

Before starting, fill the packing nut (8) 1/3 full with Graco Throat Seal Liquid (TSL) or compatible solvent. See Fig. 3.

WARNING

To reduce the risk of serious injury whenever you are instructed to relieve pressure, always follow the **Pressure Relief Procedure** at left.

The packing nut is torqued at the factory and is ready for operation. If it becomes loose and there is leaking from the throat packings, relieve pressure, then torque the nut to 61–75 N•m (45–55 ft-lb) using the supplied wrench (110). Do this whenever necessary. Do not overtighten the packing nut.

 Torque to 61–75 N•m
(45–55 ft-lb)

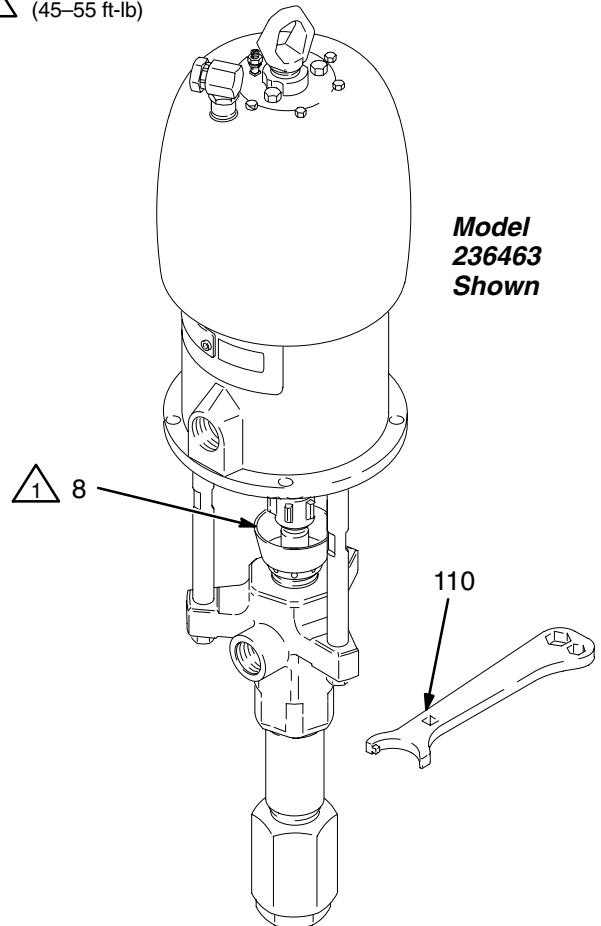

Fig. 3

05242

Operation/Maintenance

Flush the Pump Before First Use

The pump is tested with lightweight oil, which is left in to protect the pump parts. If the fluid you are using may be contaminated by the oil, flush it out with a compatible solvent. See **Flushing** on page 12.

Starting and Adjusting the Pump

1. See Fig. 2. Connect the suction kit (T) to the pump's fluid inlet. Place the tube into the fluid supply.
2. Close the air regulator (F).
3. Open the pump's bleed-type master air valve (E).
4. Hold a metal part of the gun (S) firmly to the side of a grounded metal pail and hold the trigger open.
5. Slowly open the regulator until the pump starts.
6. Cycle the pump slowly until all air is pushed out and the pump and hoses are fully primed.
7. Release the gun trigger and lock the trigger safety. The pump should stall against pressure.
8. If the pump fails to prime properly, open the drain valve (M). Use the drain valve as a priming valve until the fluid flows from the valve. Close the valve.

NOTE: When changing fluid containers with the hose and gun already primed, open the drain valve (M) to help prime the pump and vent air before it enters the hose. Close the drain valve when all air is eliminated.

CAUTION

Do not allow the pump to run dry. It will quickly accelerate to a high speed, causing damage. If your pump is running too fast, stop it immediately and check the fluid supply. If the container is empty and air has been pumped into the lines, refill the container and prime the pump and the lines, or flush and leave it filled with a compatible solvent. Eliminate all air from the fluid system.

9. With the pump and lines primed, and with adequate air pressure and volume supplied, the pump will start and stop as you open and close the gun. In a circulating system, the pump will speed up or slow down on demand, until the air supply is shut off.

WARNING

COMPONENT RUPTURE HAZARD



To reduce the risk of overpressurizing your system, which could cause component rupture and serious injury, *never exceed the specified Maximum Incoming Air Pressure to the pump* (see **Technical Data**, page 25).

10. Use the air regulator (F) to control pump speed and fluid pressure. Always use the lowest air pressure necessary to get the desired results. Higher pressures cause premature tip and pump wear.

Operation/Maintenance

Shutdown and Care of the Pump

WARNING

To reduce the risk of serious injury whenever you are instructed to relieve pressure, always follow the **Pressure Relief Procedure** on page 10.

For overnight shutdown, stop the pump at the bottom of its stroke to prevent fluid from drying on the exposed displacement rod and damaging the throat packings. Relieve the pressure.

Always flush the pump before the fluid dries on the displacement rod. See **Flushing** below.

Flushing

WARNING



FIRE AND EXPLOSION HAZARD

Before flushing, read the section **FIRE AND EXPLOSION HAZARD** on page 5. Be sure the entire system and flushing pails are properly grounded. Refer to **Grounding** on page 7.



Flush with a fluid that is compatible with the fluid you are pumping and with the wetted parts in your system. Check with your fluid manufacturer or supplier for recommended flushing fluids and flushing frequency. Always flush the pump before fluid dries on the displacement rod.

CAUTION

Never leave water or water-base fluid in the pump overnight. If you are pumping water-base fluid, flush with water first, then with a rust inhibitor such as mineral spirits. Relieve the pressure, but leave the rust inhibitor in the pump to protect the parts from corrosion.

WARNING

To reduce the risk of serious injury whenever you are instructed to relieve pressure, always follow the **Pressure Relief Procedure** on page 10.

1. Relieve the pressure.
2. Remove the spray tip from the gun.
3. Hold a metal part of the gun firmly to the side of a grounded *metal* pail.
4. Start the pump. Always use the lowest possible fluid pressure when flushing.
5. Trigger the gun.
6. Flush the system until clear solvent flows from the gun.
7. Relieve the pressure.

Troubleshooting Chart

WARNING

To reduce the risk of serious injury whenever you are instructed to relieve pressure, always follow the **Pressure Relief Procedure** on page 10.

1. Relieve the pressure.
2. Check all possible causes and problems before disassembling the pump.

PROBLEM	CAUSE	SOLUTION
The pump fails to operate.	Valves are closed or clogged.	Clear the air line; increase the air supply. Check that the valves are open.
	The fluid hose or gun is obstructed.	Clear the hose or gun*; use a hose with a larger ID.
	Fluid has dried on the displacement rod.	Clean the rod; always stop the pump at the bottom of its stroke; keep the wet-cup 1/3 filled with a compatible solvent.
	Air motor parts are dirty, worn, or damaged.	Clean or repair the air motor; see the separate motor manual.
The pump operates, but the output is low on both strokes.	The air line is restricted or the air supply is inadequate. Valves are closed or clogged.	Clear the air line; increase the air supply. Check that the valves are open.
	The fluid hose or gun is obstructed; the fluid hose ID is too small.	Clear the hose or gun*; use a hose with a larger ID.
	Worn packings in the displacement pump.	Replace the packings.
	Air motor parts are dirty, worn, or damaged.	Clean or repair the air motor; see the separate motor manual.
	Held open or worn intake valve.	Clear or service the intake valve.
The pump operates, but the output is low on the downstroke.	Held open or worn intake valve.	Clear or service the intake valve.
The pump operates, but the output is low on the upstroke.	Held open or worn piston valve or packings.	Clear the piston valve; replace the packings.
The pump's speed is erratic or accelerated.	The fluid supply is exhausted.	Refill the supply and prime the pump.
	Held open or worn piston valve or packings.	Clear the piston valve; replace the packings.
	Held open or worn intake valve.	Clear or service the intake valve.

* To determine if the fluid hose or gun is obstructed, relieve the pressure. Disconnect the fluid hose and place a container at the pump fluid outlet to catch any fluid. Turn on the air just enough to start the pump. If the pump starts when the air is turned on, the obstruction is in the fluid hose or gun.

NOTE: If you experience air motor icing, call your Graco distributor.

Service

Required Tools

- Set of adjustable wrenches
- Large pipe wrench
- 2–3/4 in. socket wrench
- Torque wrench
- Rubber mallet
- O-ring pick
- Large vise
- Plastic or wooden block, approximately 6 in. square x 1 in. thick
- Thread lubricant
- Thread sealant

Disconnecting the Displacement Pump

1. Flush the pump, if possible. Stop the pump at the bottom of its stroke.

WARNING

To reduce the risk of serious injury whenever you are instructed to relieve pressure, always follow the **Pressure Relief Procedure** on page 10.

2. Relieve the pressure.
3. Disconnect the air hose and fluid hose.
4. Disconnect the displacement pump (109) from the motor (101) as follows. Note the relative position of the pump's fluid outlet (U) to the air inlet (V) of the motor. If the motor does not require servicing, leave it attached to its mounting.

CAUTION

Be sure to use two people when lifting, moving, or disconnecting the entire pump. This pump is too heavy for one person. If you are disconnecting the displacement pump from a motor which is still mounted (for example, on a wall bracket), only one person is required. The displacement pump weighs approximately 15 kg (33 lb).

If the pump is mounted on a cart, slowly tip the cart backward until the handle rests on the ground, then disconnect the displacement pump.

5. Using an adjustable wrench (or hammer and punch), unscrew the coupling nut (106) from the motor shaft (W). Do not lose or drop the coupling collars (107). See Fig. 4.

NOTE: On Model 237–371, disconnect the riser tube (113) at either the elbow (112) or the connector (114). See the Parts Drawing on page 22.

6. Hold the tie rod flats with a wrench to keep the rods from turning. Unscrew the nuts (108) from the tie rods (105). Carefully remove the displacement pump (109) from the motor (101).
7. Refer to page 16 for displacement pump service. To service the air motor, refer to the separate motor manual, supplied.

Reconnecting the Displacement Pump

1. Make sure the coupling nut (106) and the coupling collars (107) are in place on the displacement rod (1). See Fig. 4.
2. Have one person hold the displacement pump while another reconnects it to the motor (see the **CAUTION** at left). Orient the pump's fluid outlet (U) to the air inlet (V) as was noted in step 4 under **Disconnecting the Displacement Pump**. Position the displacement pump (109) on the tie rods (105).

NOTE: On Model 237371, reconnect the riser tube (113) at either the elbow (112) or the connector (114).

3. Screw the nuts (108) onto the tie rods (105) and torque to 68–81 N•m (50–60 ft-lb).
4. Screw the coupling nut onto the motor shaft (W) loosely. Hold the motor shaft flats with a wrench to keep it from turning. Use an adjustable wrench to tighten the coupling nut. Torque to 195–210 N•m (145–155 ft-lb).
5. Reconnect all hoses. Reconnect the ground wire if it was disconnected. Fill the packing nut (8) 1/3 full of Graco Throat Seal Liquid or compatible solvent.
6. Turn on the air supply. Run the pump slowly to ensure proper operation.

WARNING

To reduce the risk of serious injury whenever you are instructed to relieve pressure, always follow the **Pressure Relief Procedure** on page 10.

7. Before returning the pump to production, relieve the pressure and retorque the packing nut (8) to 61–75 N•m (45–55 ft-lb).

Service

Model 236463 Shown

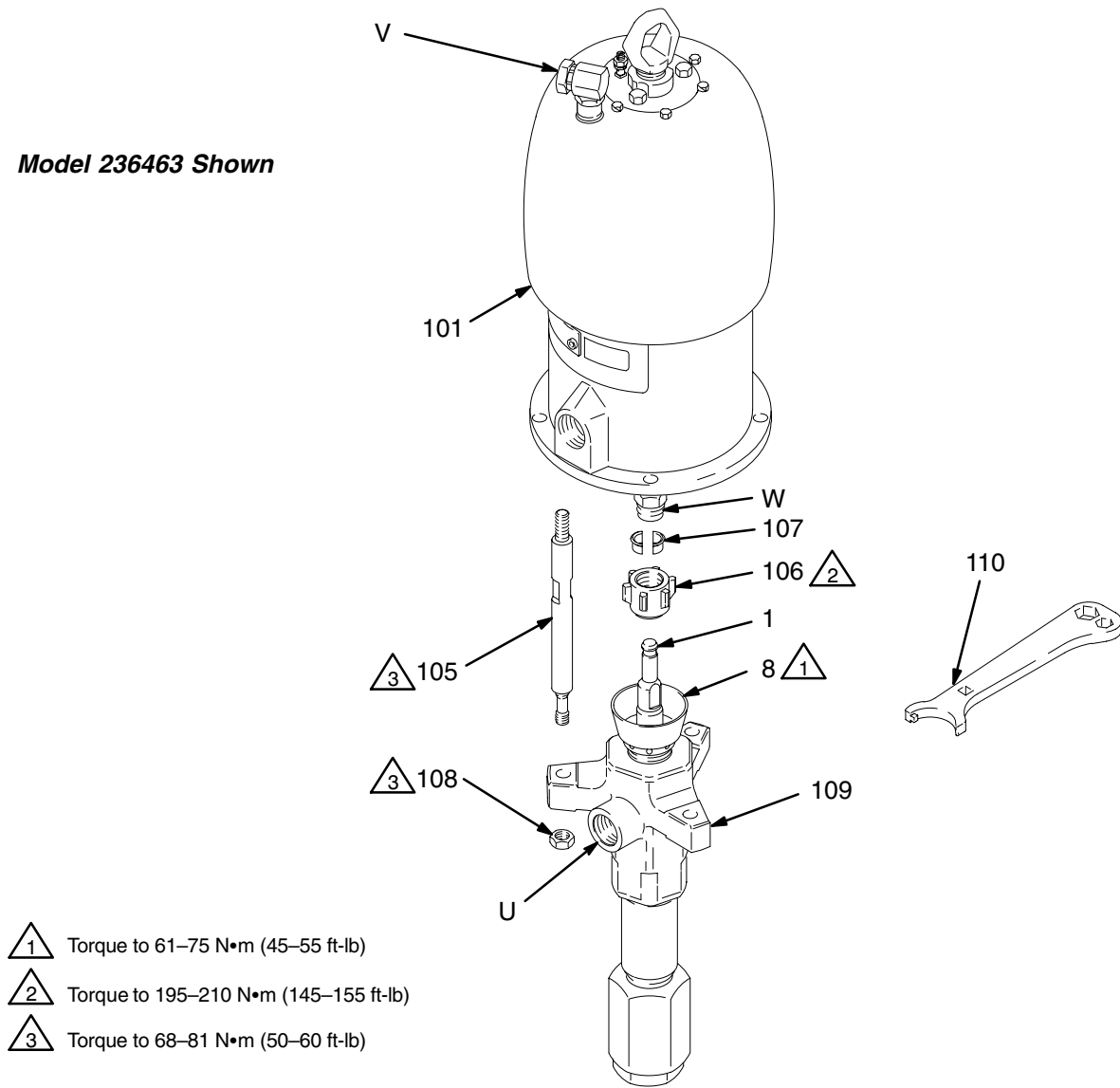

Fig. 4

05243

Service

DISPLACEMENT PUMP SERVICE

Disassembly

When disassembling the pump, lay out all the removed parts in sequence, to ease reassembly.

NOTE: Packing Repair Kits are available. For the best results, use all the new parts in the kit. Kit parts are marked with an asterisk, for example (3*). You can also convert the pump to different packing materials. Refer to page 24.

1. Place the pump lengthwise in a large vise, with the jaws on the outlet housing (6) as shown in Fig. 5. Using the supplied wrench (110), loosen, but do not remove, the packing nut (8).

2. Using a 2-3/4 in. socket or a pipe wrench, unscrew the intake valve (5) from the intake housing (7). Be careful to catch the intake ball (13) as you remove the intake valve, so that it does not fall and suffer damage. Remove the seal (31) from the intake valve. Inspect the ball and the seat (D) of the intake valve for wear or damage.
3. Using a pipe wrench, remove the intake housing (7) from the cylinder (2).

NOTE: These instructions are written with the pump separating at joint A. If it separates at joint B, disassemble it at that joint, place the intake housing (7) in a vise, and continue with step 4.

4. Using a pipe wrench, unscrew the cylinder (2). The displacement rod (1) may come with the cylinder.

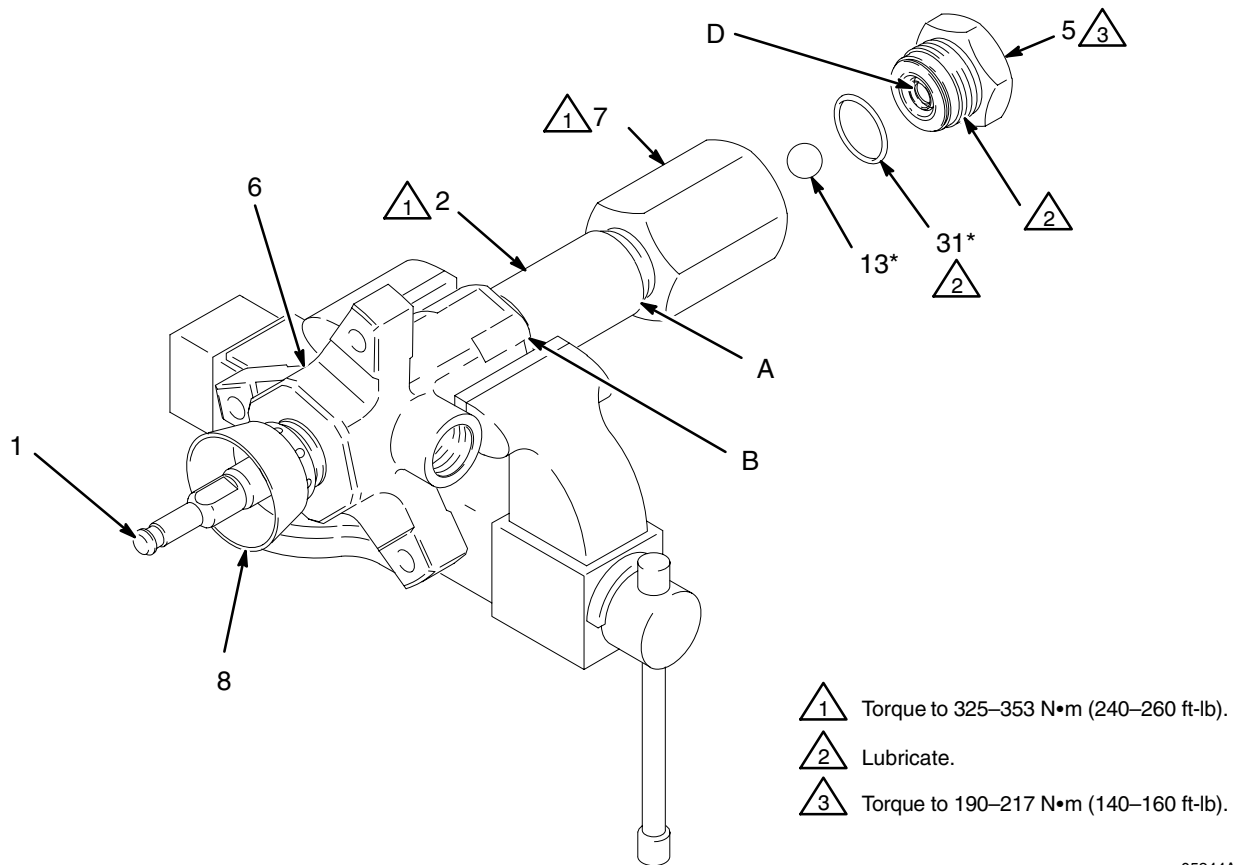

05244A

Fig. 5

Service

⚠ CAUTION

To reduce the possibility of costly damage to the rod (1) and cylinder (2), *always* use a plastic or wooden block to help drive the rod out of the cylinder. *Never* hit the rod with a hammer.

- Turn the cylinder (2) upside down and strike the top of the rod (1) on a plastic or wooden block until the piston comes free. Pull the rod and piston from the cylinder, being careful not to scratch the parts. See Fig. 6.

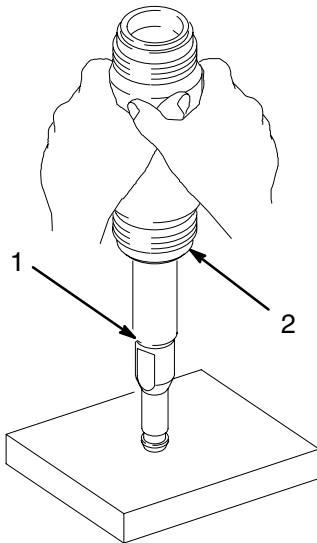

04518

Fig. 6

- Shine a light into the cylinder (2) to inspect the inner surface for scoring or wear. Remove the two seals (11) from the cylinder.
- Place the flats of the piston seat housing (10) in a vise, as shown in Fig. 7.
- Using an adjustable wrench, unscrew the piston ball housing (9) from the piston seat housing. Be careful to catch the piston ball (12) as you separate the piston seat housing and ball housing, so that it does not fall and suffer damage.
- Examine the displacement rod (1) for scratches or other damage. **Only if the rod needs replacement**, place the piston ball housing (9) in a vise and unscrew the rod, using an adjustable wrench on the flats of the rod.
- Remove the glands and v-packings (P) and the ball (12) from the piston seat housing (10). Inspect the ball seat (E) and ball guides (F) for wear or damage. See Fig. 9.
- Unscrew the packing nut (8) from the outlet housing (6). Remove the glands and v-packings (T). See Fig. 9.
- Clean all parts with a compatible solvent and inspect them for wear or damage.

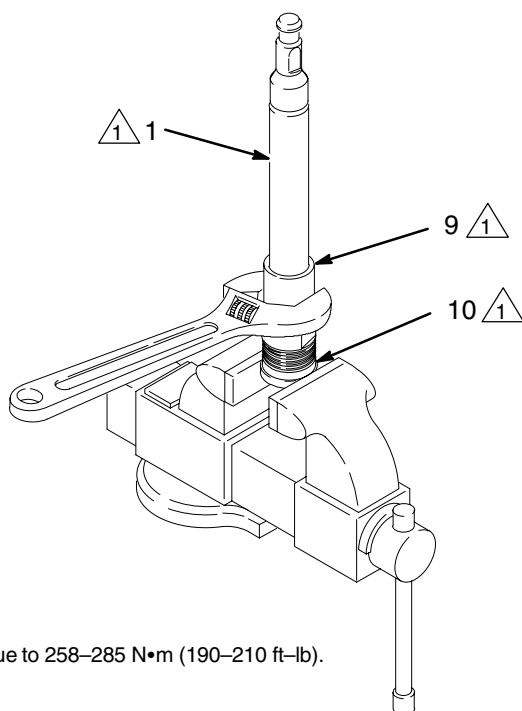

⚠ Torque to 258–285 N•m (190–210 ft–lb).

04495

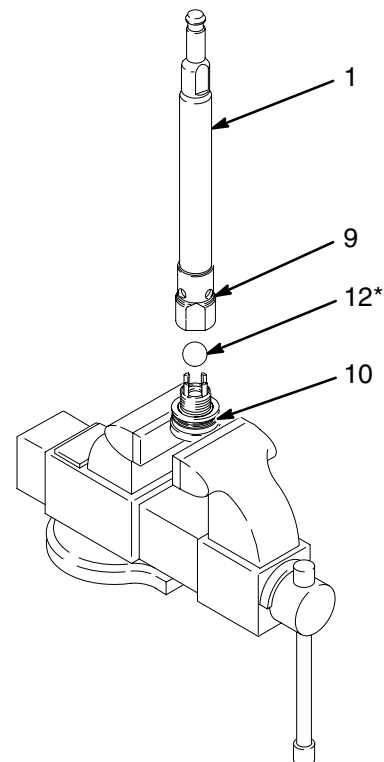

04494

Fig. 7

Service

Reassembly

1. If it was necessary to remove the piston ball housing (9) from the displacement rod (1), clean the threads of the rod and the ball housing, and apply thread sealant. Screw the ball housing onto the rod, hand tight. Place the flats of the piston ball housing in a vise and torque the rod to 258–285 N•m (190–210 ft-lb). See Fig. 9.
2. For standard displacement pump 236457, place the piston packings on the piston seat housing (10) in the following order, **with the lips of the v-packings facing up**: the female gland (4*), one PTFE v-packing (18*), four leather v-packings (19*), and the male gland (3*). See the Piston Packing Detail in Fig. 9.

NOTE: To convert the pump to a different packing material, see page 24.

3. Place the flats of the piston seat housing (10) in a vise. Place the ball (12*) on the seat. Screw the piston ball housing (9) onto the piston seat housing hand tight, then torque to 258–285 N•m (190–210 ft-lb). See Fig. 7.

4. For standard displacement pump 236457, lubricate the throat packings and place them in the outlet housing (6) in the following order, **with the lips of the v-packings facing down**: the male gland (3*), four leather v-packings (19*), one PTFE v-packing (18*), and the female gland (4*). See the Throat Packing Detail in Fig. 9.

NOTE: To convert the pump to a different packing material, see page 24.

5. Lubricate the threads of the packing nut (8), and loosely install it in the outlet housing (6).
6. Lubricate the piston packings. Slide the displacement rod (1) and piston assembly down into the cylinder (2). The cylinder is symmetrical, so either end may face up. Use a rubber mallet to drive the rod into the cylinder, until the piston seat housing (10) is located in the middle of the cylinder.
7. Install the seal (11*) on the top of the cylinder (2). Lubricate the seal and the top threads of the cylinder.
8. Place the outlet housing (6) in a vise, as shown in Fig. 8. Slide the displacement rod (1) up into the outlet housing, then screw the cylinder (2) into the outlet housing handtight. The threads will engage easily until the seal (11*) contacts the sealing surface of the outlet housing. The top of the rod will protrude from the packing nut (8).

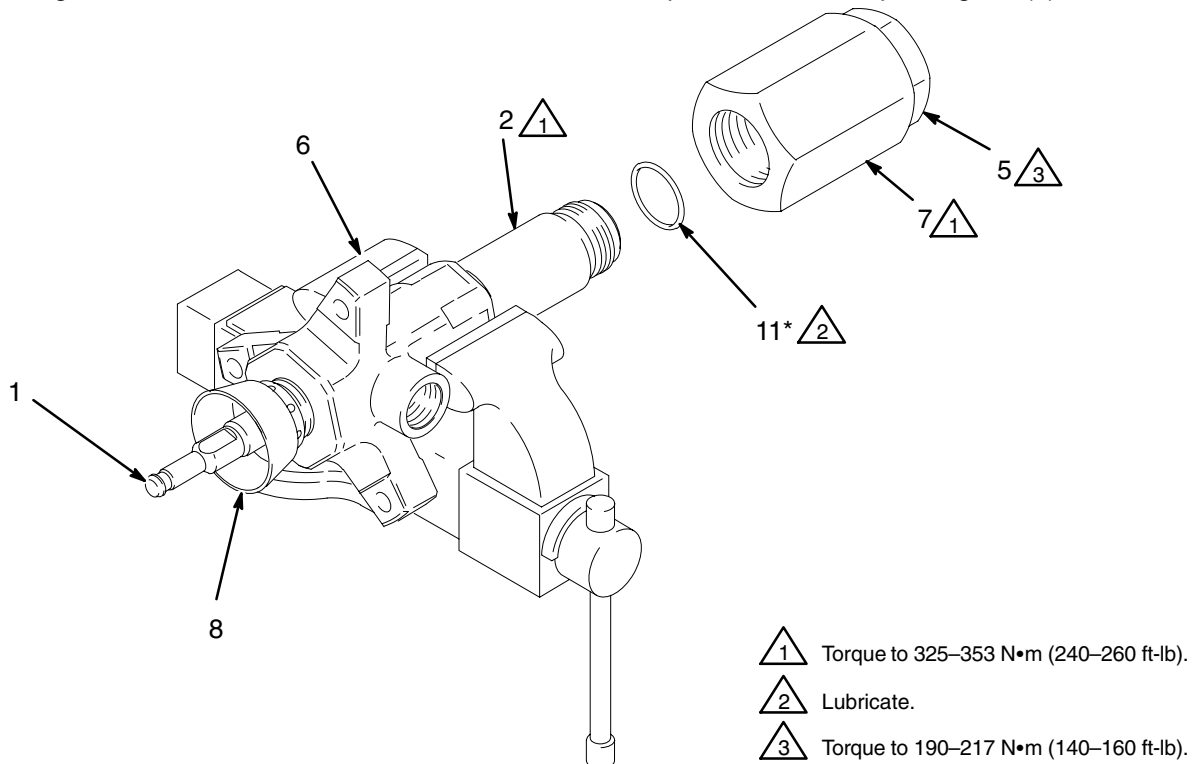

Fig. 8

05251

Service

△1 Torque to 61–75 N•m (45–55 ft-lb).

△2 Torque to 325–353 N•m (240–260 ft-lb).

△3 Torque to 258–285 N•m (190–210 ft-lb).

△4 Lubricate.

△6 Lips face up.

△7 Lips face down.

△8 See the Throat Packing Detail at left.

△9 See the Piston Packing Detail at left.

△10 Torque to 190–217 N•m (140–160 ft-lb).

Throat Packing Detail
(Displacement Pump 236457 Shown;
see page 24 for options.)

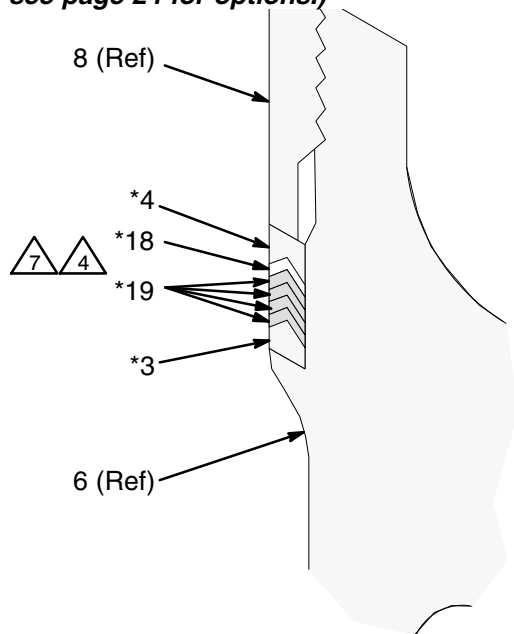

Piston Packing Detail
(Displacement Pump 236457 Shown;
see page 24 for options.)

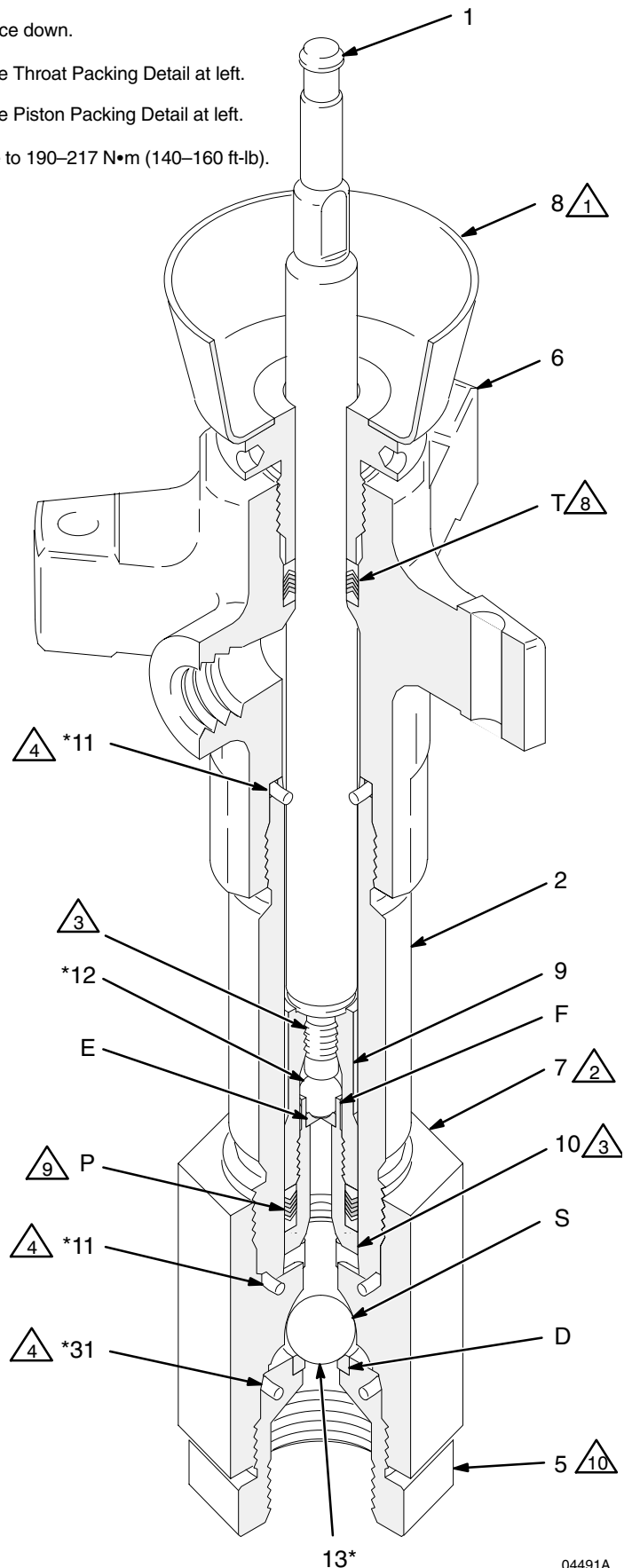
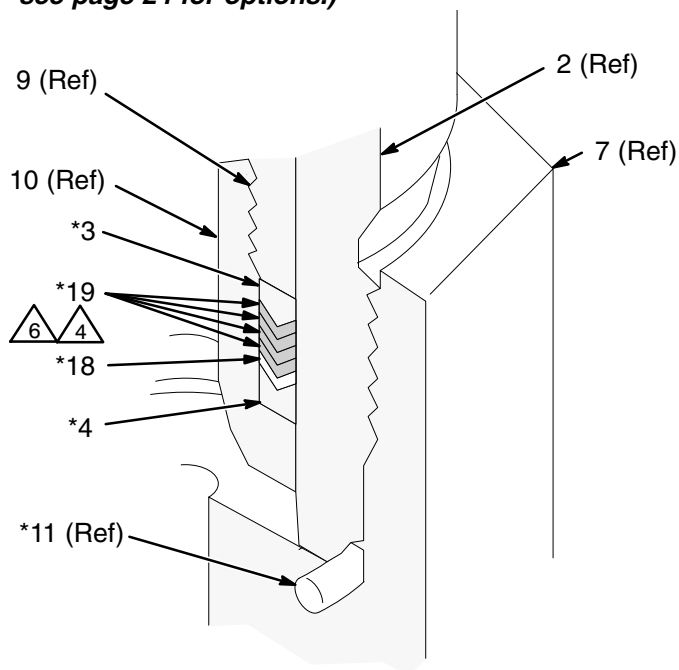

Fig. 9

04491A

Service

9. Install the seal (31*) on the intake valve (5). Lubricate the seal and the threads of the intake valve.
10. One end of the intake housing (7) has a rounded ball cavity (S) on the inside (see Fig. 9). Install the ball (13*) in this cavity, then screw the intake valve (5) into the intake housing handtight. See Fig. 10. The threads will engage easily until the seal contacts the sealing surface of the intake housing.

1 Orient so the end with the ball cavity (S, see Fig. 9) faces the ball (13*).

2 Lubricate.

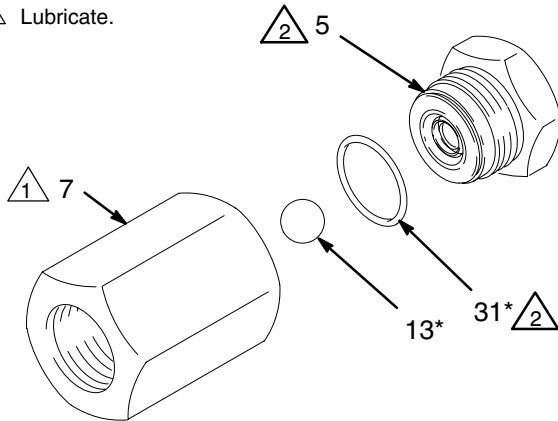

Fig. 10

05245A

11. Install the seal (11*) on the bottom of the cylinder (2). See Fig. 8. Lubricate the seal and the threads of the cylinder. Screw the intake housing (7) onto the cylinder handtight. The threads will engage easily until the seal contacts the sealing surface of the intake housing.
12. Using a pipe wrench, torque the intake housing (7) to 325–353 N•m (240–260 ft-lb). This will also torque the cylinder (2) into the outlet housing (6). See Fig. 8.
13. Using a 2–3/4 in. socket or a pipe wrench, torque the intake valve (5) to 190–217 N•m (140–160 ft-lb).
14. Torque the packing nut (8) to 61–75 N•m (45–55 ft-lb).
15. Reconnect the displacement pump to the air motor as explained on page 14.

Parts

Part No. 236463 Pump, Series A 41:1 Ratio, with Bulldog Air Motor

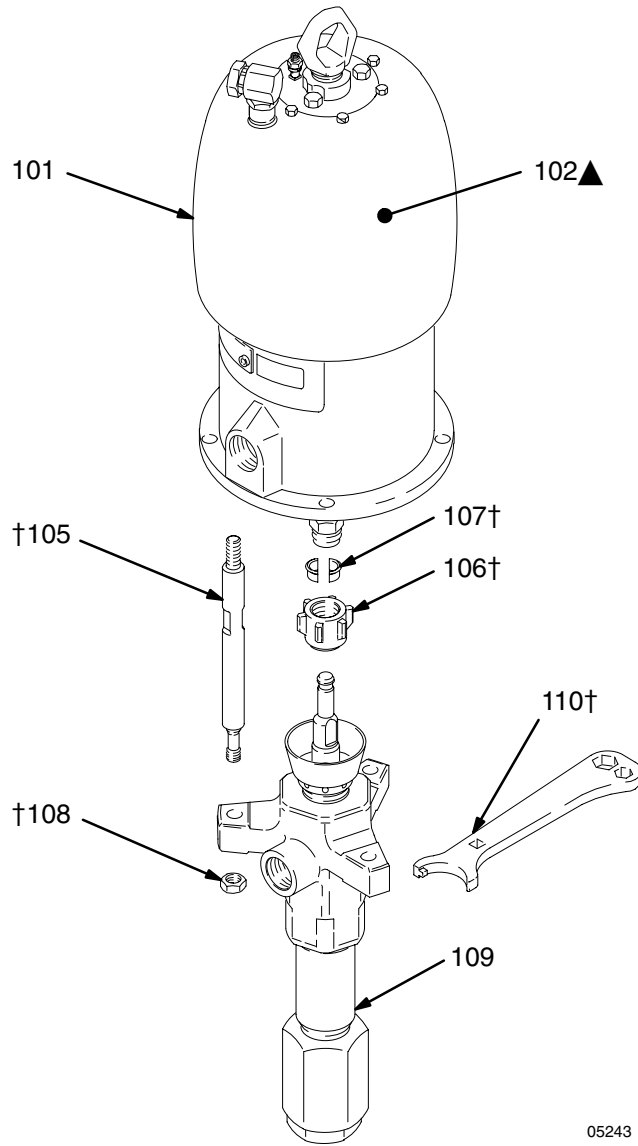

05243

Part No. 237369 Pump, Series A 41:1 Ratio, with Reduced Icing Quiet Bulldog Air Motor

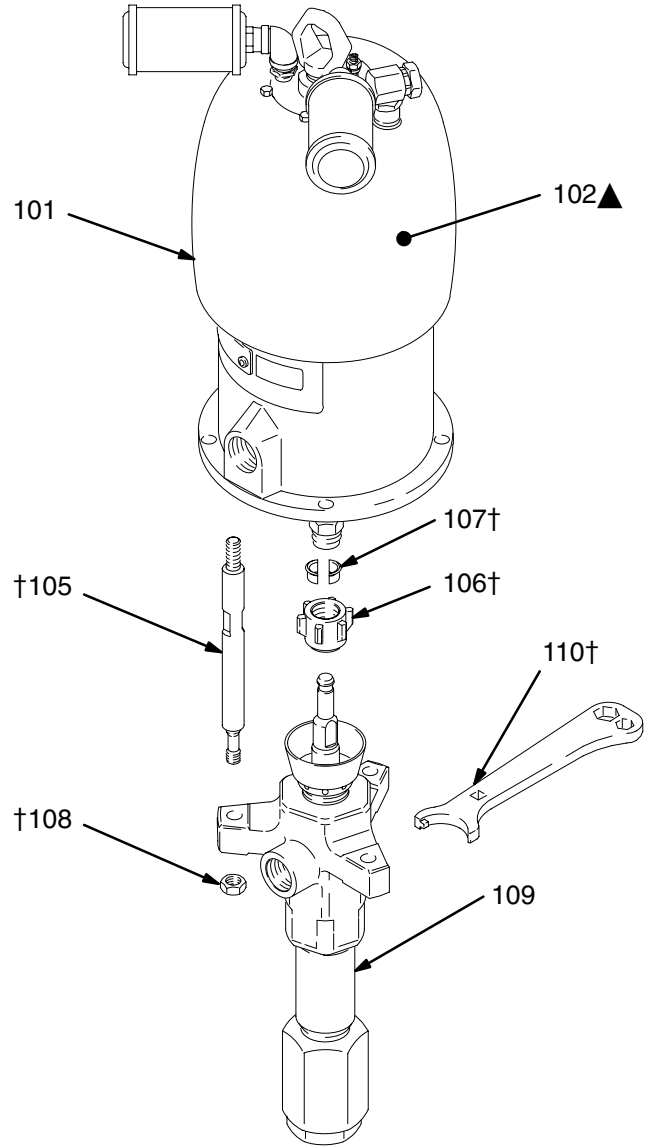

05248

Ref. No.	Part No.	Description	Qty.
101	208356	AIR MOTOR, Bulldog See 307049 for parts	1
102▲	176529	LABEL, warning	1
105†	190000	ROD, tie; 224 mm (8.82") shoulder to shoulder	3
106†	186925	NUT, coupling	1
107†	184129	COLLAR, coupling	2
108†	106166	NUT, hex; M16 x 2.0	3
109	236457	PUMP, displacement See page 23 for parts	1
110†	112887	WRENCH, spanner	1

▲ Replacement Danger and Warning labels, tags and cards are available at no cost.

† These parts are included in Connection Kit 235417.

Ref. No.	Part No.	Description	Qty.
101	237001	AIR MOTOR, Bulldog See 307304 for parts	1
102▲	176529	LABEL, warning	1
105†	190000	ROD, tie; 224 mm (8.82") shoulder to shoulder	3
106†	186925	NUT, coupling	1
107†	184129	COLLAR, coupling	2
108†	106166	NUT, hex; M16 x 2.0	3
109	236457	PUMP, displacement See page 23 for parts	1
110†	112887	WRENCH, spanner	1

▲ Replacement Danger and Warning labels, tags and cards are available at no cost.

† These parts are included in Connection Kit 235417.

Parts

Part No. 237371 Pump, Series A 41:1 Ratio, with Bulldog Air Motor and riser tube

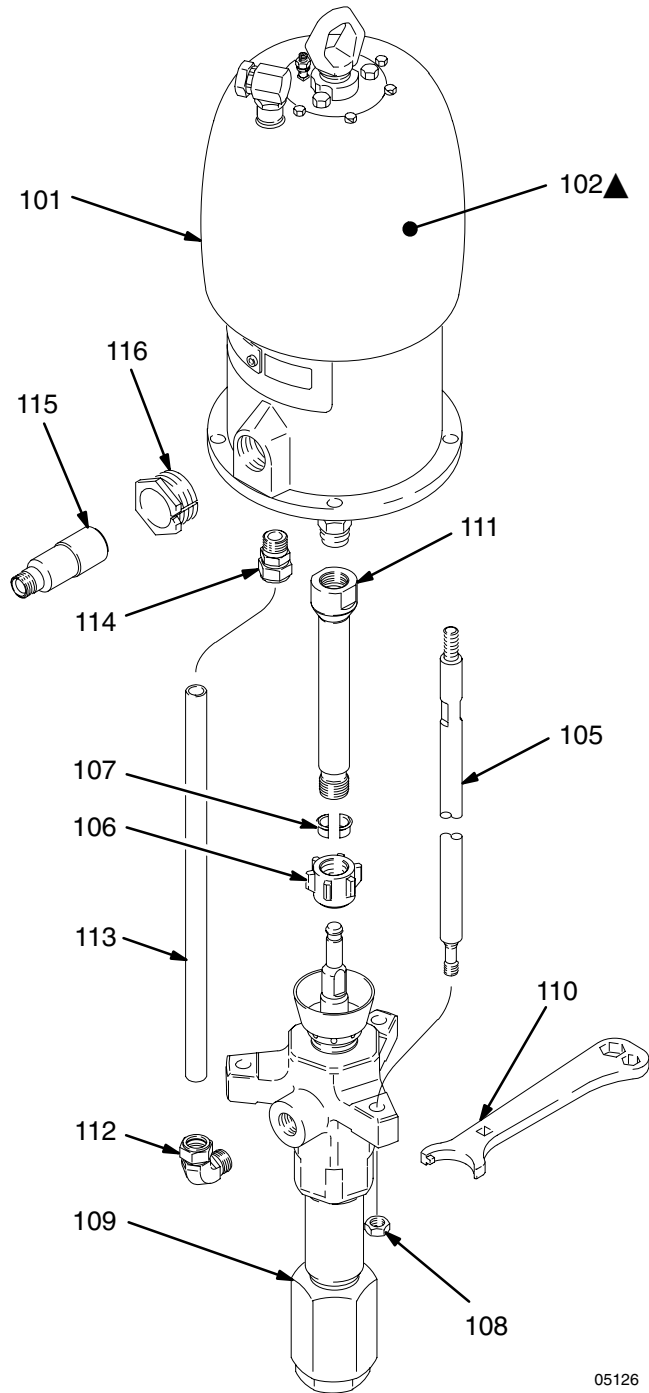

Ref. No.	Part No.	Description	Qty.
101	208356	AIR MOTOR, Bulldog See 307049 for parts	1
102▲	176529	LABEL, warning	1
105	190500	ROD, tie; 486.5 mm (19.15") shoulder to shoulder	3
106	186925	NUT, coupling	1
107	184129	COLLAR, coupling	2
108	106166	NUT, hex; M16 x 2.0	3
109	236457	PUMP, displacement See page 23 for parts	1
110	112887	WRENCH, spanner	1
111	190310	ADAPTER, rod	1
112	112976	ELBOW, tube; 3/4 npt(m) x 7/8 OD tube	1
113	190409	TUBE, riser; stainless steel; 512 mm (20.16 in.); 0.875" OD	1
114	112977	CONNECTOR, tube; 3/4 npt(m) x 7/8 OD tube	1
115	176393	ELBOW, street; 3/4 npt(m) x 3/4 npt(f)	1
116	166153	NUT, collet; 1-1/2" npt	1

▲ Replacement Danger and Warning labels, tags and cards are available at no cost.

05126

Parts

NOTE: The parts listed on this page are common to all displacement pumps covered in this manual. Refer to page 24 for the different packing configurations available.

* These parts are included in Repair Kit 237233, which may be purchased separately for standard Displacement Pump 236457. See page 24. They are also included in Optional Kits 237235, 237237, and 237609.

▲ Replacement Danger and Warning labels, tags and cards are available at no cost.

Ref No.	Part No.	Description	Qty
1	190172	ROD, displacement; stainless steel	1
2	184503	CYLINDER; stainless steel	1
5	222930	VALVE, intake; carbon steel w/tungsten carbide seat	1
6	237730	HOUSING, outlet; nickel-plated ductile iron	1
7	190393	HOUSING, intake; nickel-plated ductile iron	1
8	236577	PACKING NUT; carbon steel	1
9	184504	HOUSING, ball, piston; alloy steel	1
10	222929	HOUSING, seat, piston valve; stainless steel w/tungsten carbide seat	1
11*	109205	SEAL; PTFE	2
12*	101822	BALL, piston; stainless steel; 0.625" (16 mm) dia.	1
13*	102973	BALL, intake; stainless steel; 1-1/4" (31.8 mm) dia.	1
17	101754	PLUG, pipe, socket hd; 3/8 npt	1
20▲	172477	TAG, warning (not shown)	1
21▲	172479	TAG, warning (not shown)	1
31*	166073	SEAL; PTFE	1

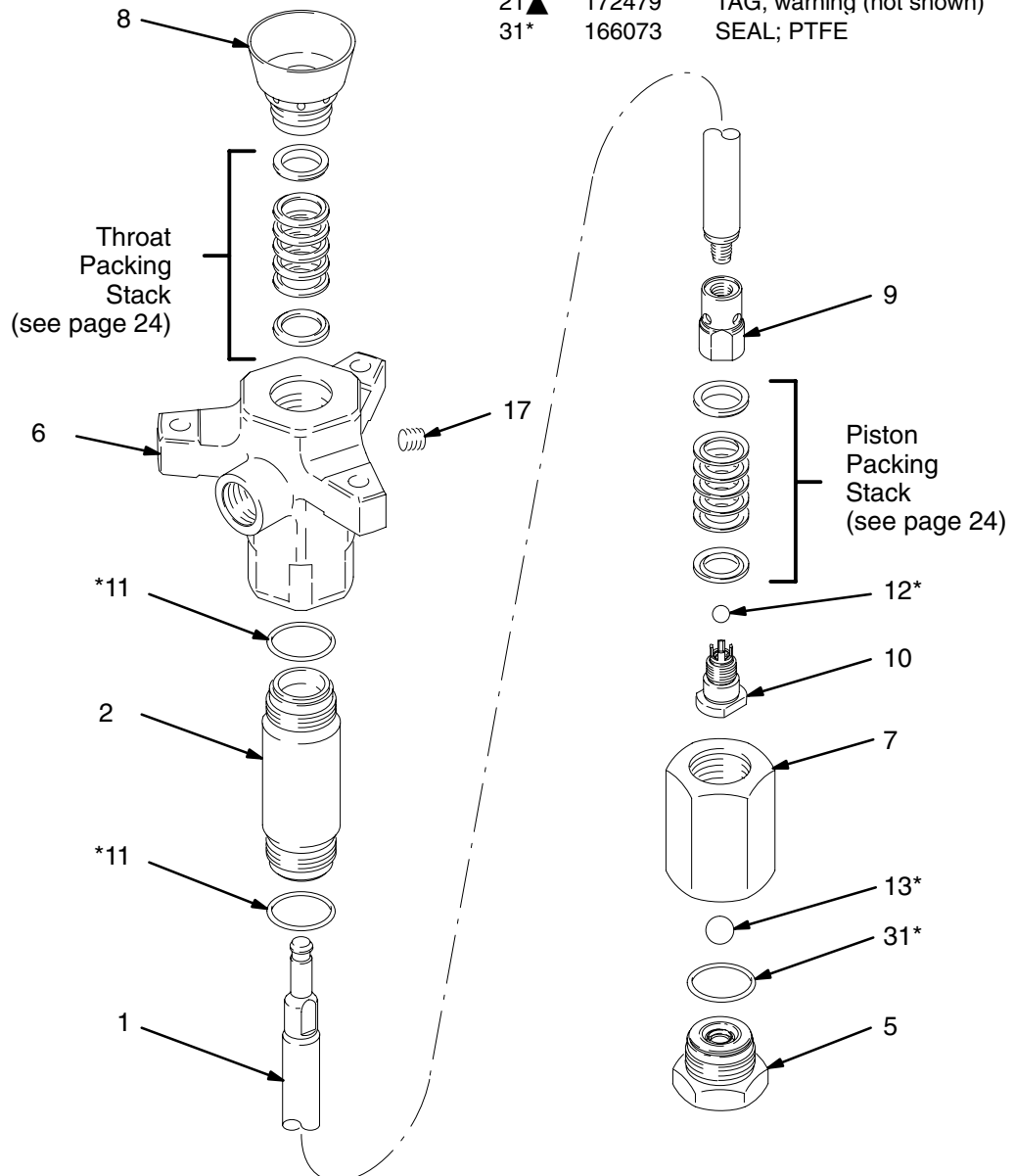

Packing Kits

Leather Packing Kit 237233, for Standard Displacement Pump 236457, Series A

Ref No.	Part No.	Description	Qty
3*	184247	GLAND, male; carbon steel	2
4*	184197	GLAND, female; carbon steel	2
18*	109302	V-PACKING; PTFE	2
19*	184302	V-PACKING; leather	8

* Kit also includes items 11, 12, 13, and 31 (see page 23).

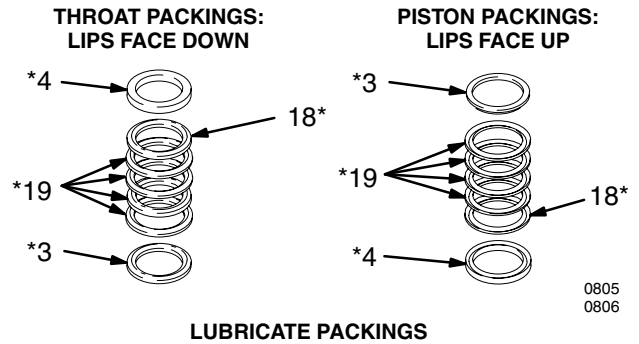

0805
0806

PTFE Packing Kit 237235, for Optional Displacement Pump 238036, Series A

Ref No.	Part No.	Description	Qty
3*	184247	GLAND, male; carbon steel	2
4*	184197	GLAND, female; carbon steel	2
18*	109302	V-PACKING; PTFE	10

* Kit also includes items 11, 12, 13, and 31 (see page 23).

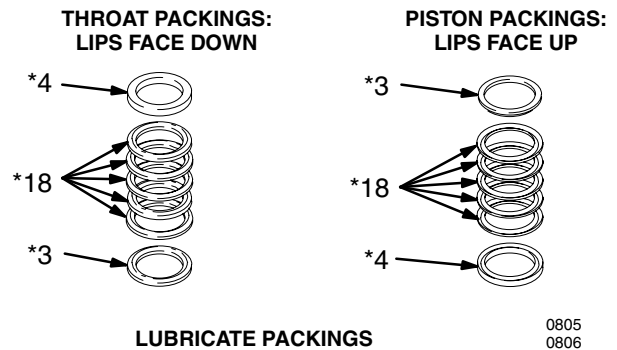

0805
0806

UHMWPE/Leather Packing Kit 237237 (Optional)

Ref No.	Part No.	Description	Qty
3*	184247	GLAND, male; carbon steel	2
4*	184197	GLAND, female; carbon steel	2
18*	109252	V-PACKING; UHMWPE	6
19*	184302	V-PACKING; leather	4

* Kit also includes items 11, 12, 13, and 31 (see page 23).

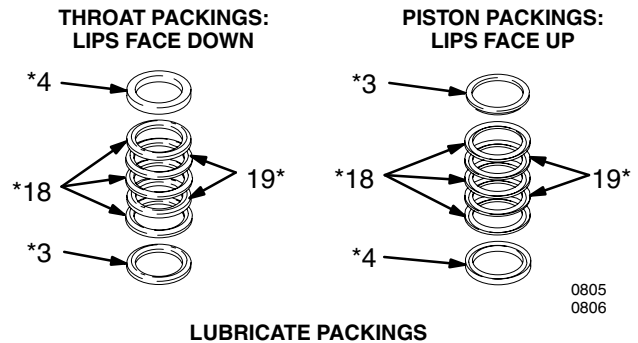

0805
0806

UHMWPE/PTFE Packing Kit 237609 (Optional)

Ref No.	Part No.	Description	Qty
3*	184222	GLAND, male; stainless steel	2
4*	184172	GLAND, female; stainless steel	2
18*	109252	V-PACKING; UHMWPE	6
19*	109302	V-PACKING; PTFE	4

* Kit also includes items 11, 12, 13, and 31 (see page 23).

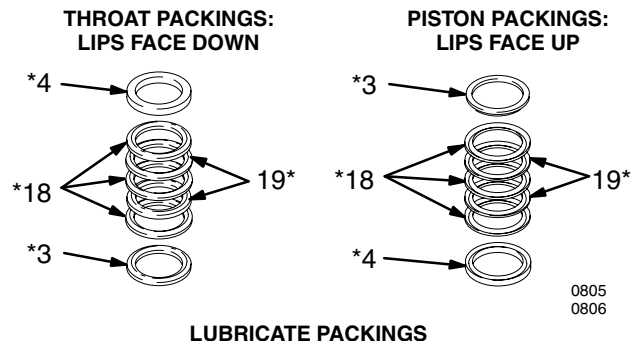

0805
0806

Technical Data

⚠ WARNING

Be sure that all fluids and solvents used are chemically compatible with the Wetted Parts listed below. Always read the manufacturer's literature before using fluid or solvent in this pump.

Category	Data
Maximum fluid working pressure	28.3 MPa, 283 bar (4100 psi)
Maximum air input pressure	0.7 MPa, 7 bar (100 psi)
Ratio	41:1
Pump cycles per 3.8 liters (1 gallon)	26
Fluid flow at 60 cycles per minute	8.7 liters/min (2.3 gpm)
Air motor piston effective area	248 cm ² (38 in. ²)
Stroke length	120 mm (4.75 in.)
Displacement pump effective area	6 cm ² (0.93 in. ²)
Maximum operating temperature	82°C (180°F)
Air inlet size	3/4 npsm(f)
Fluid inlet size	1-1/2" npt(f)
Fluid outlet size	3/4 npt(f)
Pump weight	approx. 41 kg (90 lb)
Displacement pump weight	approx. 15 kg (33 lb)
Wetted parts	Carbon Steel; Alloy Steel; 304, 440 and 17-4 PH Grades of Stainless Steel; Zinc and Nickel Plating; Ductile Iron; Tungsten Carbide; PTFE; Leather

PTFE®

Sound Pressure Levels (dBa) (measured at 1 meter from unit)

Air Motor	Input Air Pressures at 15 cycles per minute			
	0.28 MPa, 2.8 bar (40 psi)	0.48 MPa, 4.8 bar (70 psi)	0.63 MPa, 6.3 bar (90 psi)	0.7 MPa, 7 bar (100 psi)
Bulldog	82.4 dB(A)	87.3 dB(A)	88.5 dB(A)	90.0 dB(A)
Reduced Icing Quiet Bulldog	81.5 dB(A)	83.6 dB(A)	85.6 dB(A)	85.8 dB(A)

Sound Power Levels (dBa) (tested in accordance with ISO 9614-2)

Air Motor	Input Air Pressures at 15 cycles per minute			
	0.28 MPa, 2.8 bar (40 psi)	0.48 MPa, 4.8 bar (70 psi)	0.63 MPa, 6.3 bar (90 psi)	0.7 MPa, 7 bar (100 psi)
Bulldog	91.6 dB(A)	95.9 dB(A)	97.4 dB(A)	98.1 dB(A)
Reduced Icing Quiet Bulldog	90.2 dB(A)	93.5 dB(A)	94.9 dB(A)	93.3 dB(A)

Technical Data

KEY: Fluid Outlet Pressure – Black Curves
Air Consumption – Gray Curves

A 0.7 MPa, 7 bar (100 psi) Air Pressure
B 0.49 MPa, 4.9 bar (70 psi) Air Pressure
C 0.28 MPa, 2.8 bar (40 psi) Air Pressure

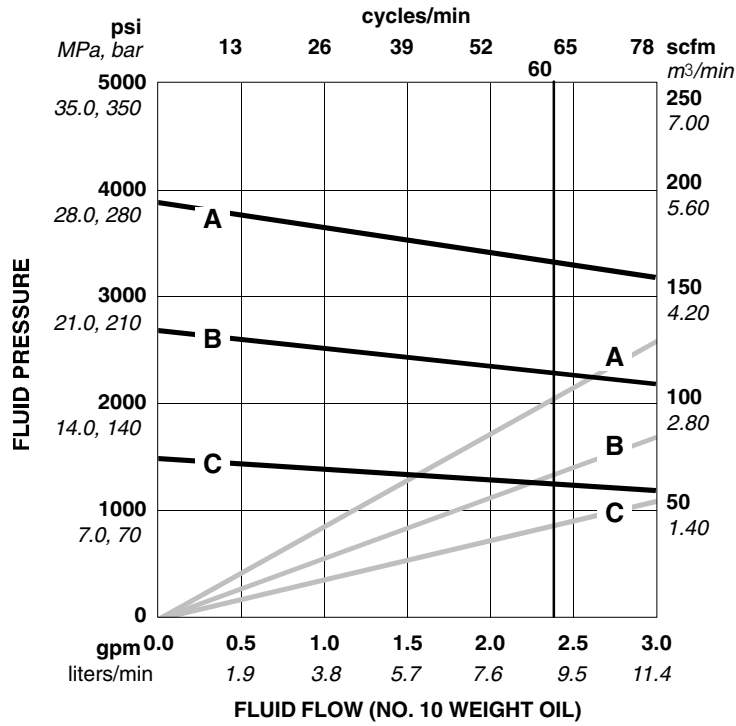

To find Fluid Outlet Pressure (MPa/bar/psi) at a specific fluid flow (lpm/gpm) and operating air pressure (MPa/bar/psi):

1. Locate desired flow along bottom of chart.
2. Follow vertical line up to intersection with selected fluid outlet pressure curve (black). Follow left to scale to read fluid outlet pressure.

To find Pump Air Consumption (m³/min or scfm) at a specific fluid flow (lpm/gpm) and air pressure (MPa/bar/psi):

1. Locate desired flow along bottom of chart.
2. Read vertical line up to intersection with selected air consumption curve (gray). Follow right to scale to read air consumption.

Dimensions

Model 236463 Shown

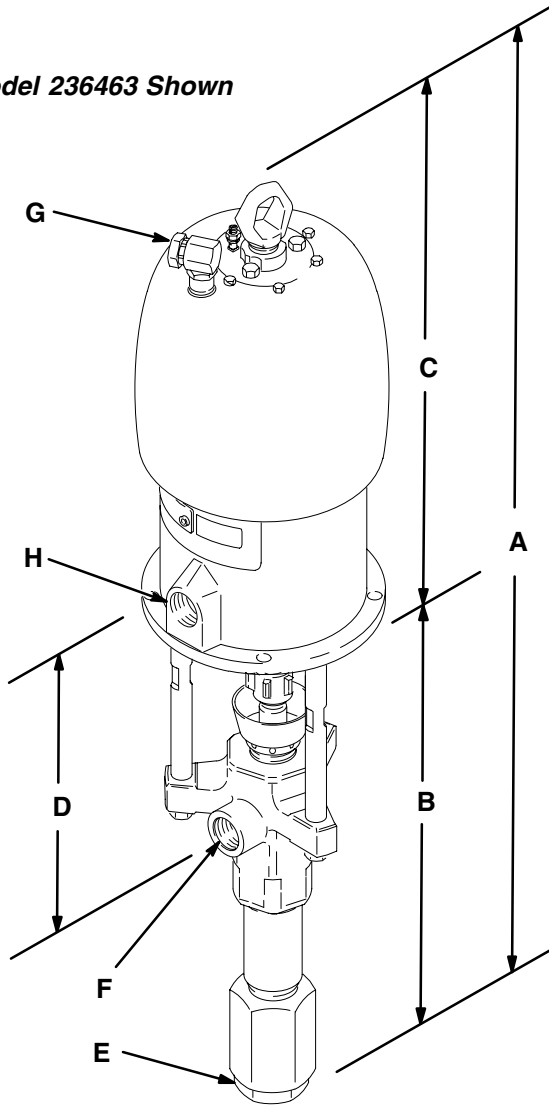

Mounting Hole Layout

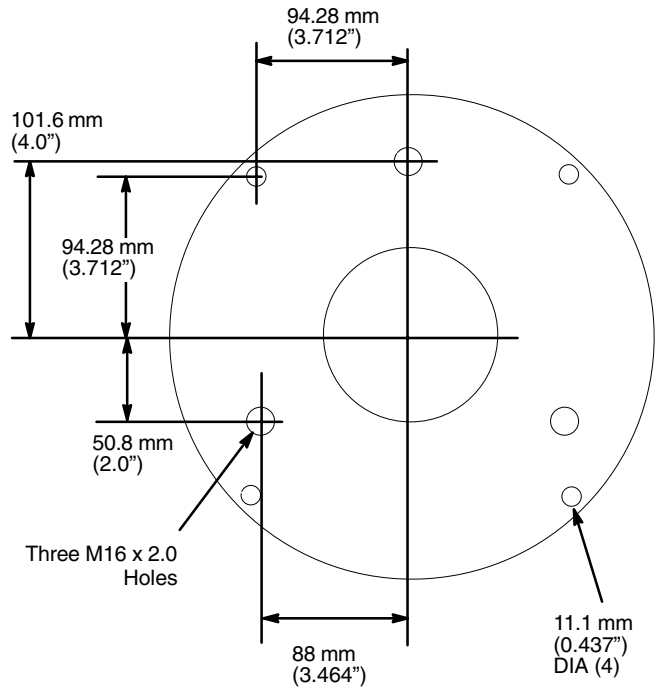

0653

05242

Pump Model	A	B	C	D	E	F	G	H
236463	1105 mm (43.50 in.)	561 mm (22.09 in.)	544 mm (21.42 in.)	257 mm (10.12 in.)	1-1/2 in. npt(f)	3/4 npt(f)	3/4 npsm(f)	1-1/2 in. npt(f)
237369	1155 mm (45.47 in.)	561 mm (22.09 in.)	594 mm (23.38 in.)	257 mm (10.12 in.)	1-1/2 in. npt(f)	3/4 npt(f)	3/4 npsm(f)	1-1/2 in. npt(f)
237371	1367 mm (53.82 in.)	823 mm (32.40 in.)	544 mm (21.42 in.)	520 mm (20.47 in.)	1-1/2 in. npt(f)	3/4 npt(f)	3/4 npsm(f)	3/4 npt(m) [not shown]

The Graco Standard Warranty

Graco warrants all equipment manufactured by Graco and bearing its name to be free from defects in material and workmanship on the date of sale by an authorized Graco distributor to the original purchaser for use. With the exception of any special, extended, or limited warranty published by Graco, Graco will, for a period of twelve months from the date of sale, repair or replace any part of the equipment determined by Graco to be defective. This warranty applies only when the equipment is installed, operated and maintained in accordance with Graco's written recommendations.

This warranty does not cover, and Graco shall not be liable for general wear and tear, or any malfunction, damage or wear caused by faulty installation, misapplication, abrasion, corrosion, inadequate or improper maintenance, negligence, accident, tampering, or substitution of non-Graco component parts. Nor shall Graco be liable for malfunction, damage or wear caused by the incompatibility of Graco equipment with structures, accessories, equipment or materials not supplied by Graco, or the improper design, manufacture, installation, operation or maintenance of structures, accessories, equipment or materials not supplied by Graco.

This warranty is conditioned upon the prepaid return of the equipment claimed to be defective to an authorized Graco distributor for verification of the claimed defect. If the claimed defect is verified, Graco will repair or replace free of charge any defective parts. The equipment will be returned to the original purchaser transportation prepaid. If inspection of the equipment does not disclose any defect in material or workmanship, repairs will be made at a reasonable charge, which charges may include the costs of parts, labor, and transportation.

THIS WARRANTY IS EXCLUSIVE, AND IS IN LIEU OF ANY OTHER WARRANTIES, EXPRESS OR IMPLIED, INCLUDING BUT NOT LIMITED TO WARRANTY OF MERCHANTABILITY OR WARRANTY OF FITNESS FOR A PARTICULAR PURPOSE.

Graco's sole obligation and buyer's sole remedy for any breach of warranty shall be as set forth above. The buyer agrees that no other remedy (including, but not limited to, incidental or consequential damages for lost profits, lost sales, injury to person or property, or any other incidental or consequential loss) shall be available. Any action for breach of warranty must be brought within two (2) years of the date of sale.

Graco makes no warranty, and disclaims all implied warranties of merchantability and fitness for a particular purpose in connection with accessories, equipment, materials or components sold but not manufactured by Graco. These items sold, but not manufactured by Graco (such as electric motors, switches, hose, etc.), are subject to the warranty, if any, of their manufacturer. Graco will provide purchaser with reasonable assistance in making any claim for breach of these warranties.

In no event will Graco be liable for indirect, incidental, special or consequential damages resulting from Graco supplying equipment hereunder, or the furnishing, performance, or use of any products or other goods sold hereto, whether due to a breach of contract, breach of warranty, the negligence of Graco, or otherwise.

FOR GRACO CANADA CUSTOMERS

The parties acknowledge that they have required that the present document, as well as all documents, notices and legal proceedings entered into, given or instituted pursuant hereto or relating directly or indirectly hereto, be drawn up in English. Les parties reconnaissent avoir convenu que la rédaction du présente document sera en Anglais, ainsi que tous documents, avis et procédures judiciaires exécutés, donnés ou intentés à la suite de ou en rapport, directement ou indirectement, avec les procédures concernées.

Graco Phone Number

TO PLACE AN ORDER, contact your Graco distributor, or call this number to identify the distributor closest to you:
1-800-367-4023 Toll Free

*All written and visual data contained in this document reflects the latest product information available at the time of publication.
Graco reserves the right to make changes at any time without notice.*

Sales Offices: Minneapolis, Detroit
International Offices: Belgium, Korea, Hong Kong, Japan

GRACO INC. P.O. BOX 1441 MINNEAPOLIS, MN 55440-1441

www.graco.com

PRINTED IN USA 308349 June 1995, Revised June 2000